

THIS DOCUMENT AND THE DATA DISCLOSED HEREIN OR HEREWITH IS THE PROPERTY OF XANBOO AND IS NOT TO BE REPRODUCED, USED OR DISCLOSED IN WHOLE OR IN PART WITHOUT THE PERMISSION OF XANBOO. ALL PATENT, PROPRIETARY, DESIGN USE, SALE, MANUFACTURING AND REPRODUCTION RIGHTS THERETO ARE RESERVED BY XANBOO.

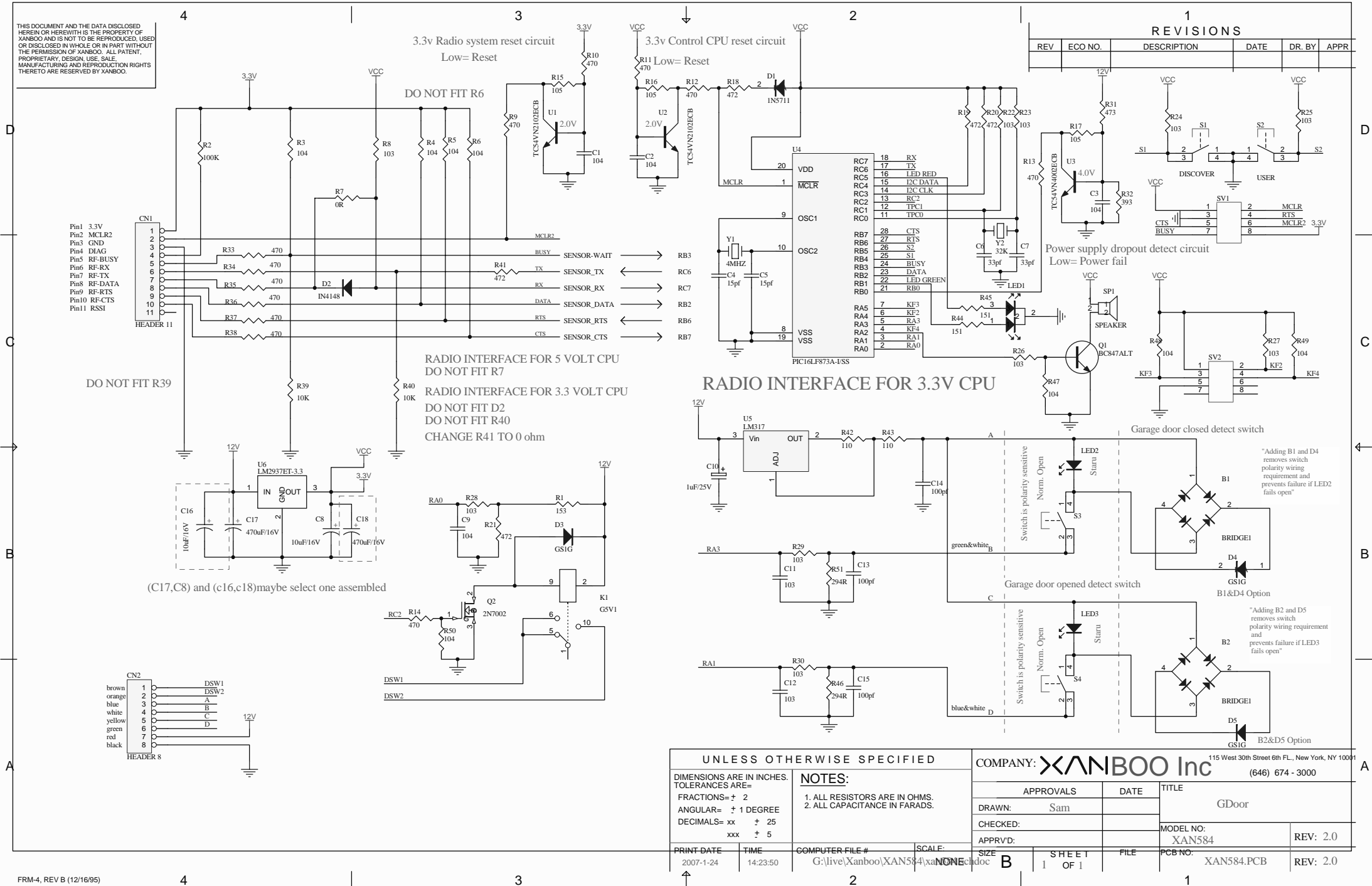

THIS DOCUMENT AND THE DATA DISCLOSED HEREIN OR HEREWITH IS THE PROPERTY OF XANBOO AND IS NOT TO BE REPRODUCED, USED OR DISCLOSED IN WHOLE OR IN PART WITHOUT THE PERMISSION OF XANBOO. ALL PATENT, PROPRIETARY, DESIGN, USE, SALE, MANUFACTURING AND REPRODUCTION RIGHTS THERE TO ARE RESERVED BY XANBOO.

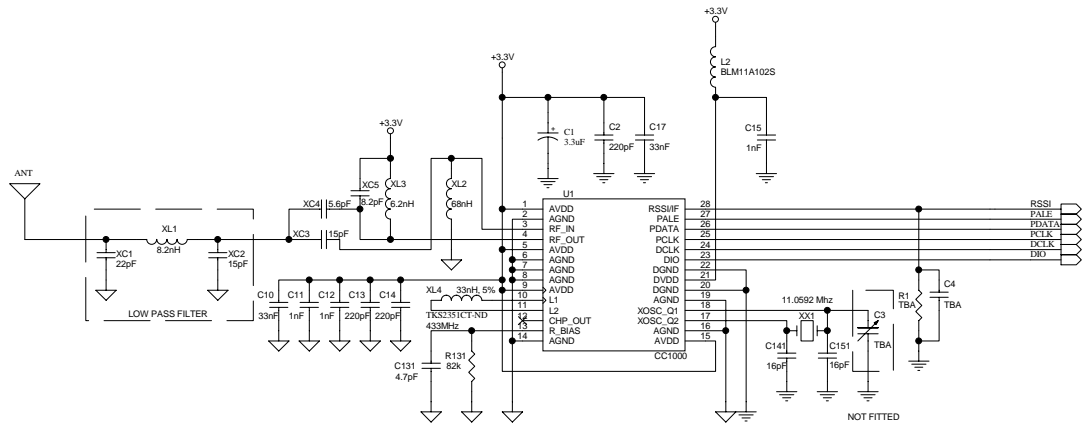

		115 West 30th Street 6th FL., New York, NY 10001 (646) 674 - 3000	
		SEE SHEET 1 FOR NOTES AND APPROVALS	
TITLE XAN0408_1_4 CC1000		SUPERSEDES XAN0408_1_4	
PRINT DATE 2004-01-14	TIME 10:07:24	FILE DRAWING NO. XAN0408 Rev1.4-02	
SIZE B	SHEET 1 OF 2		

