

49.86MHz

ANT

L1
1.0uH

C1
5P

T1
6.5T

C2
18P

Q1
2712

R3
3.9K

R1
200K

R4
2.2K

VDD

C14
104

C17
220uF

C5
332

R2
680R

L2
5.6uH

C3
18P

R6
2.2K

R5
2.2M

C7
471

C8
104

R6
2.2K

R7
2.2M

R8
2.2K

C9
332

R9
220K

C10
104

M1
MOTOR

R10
1K

R11
100R

CN1

LED

CN2

LED

R12
100R

R13
1K

VCC+6V

C12
106

C13
106

C11
104

M2
MOTOR

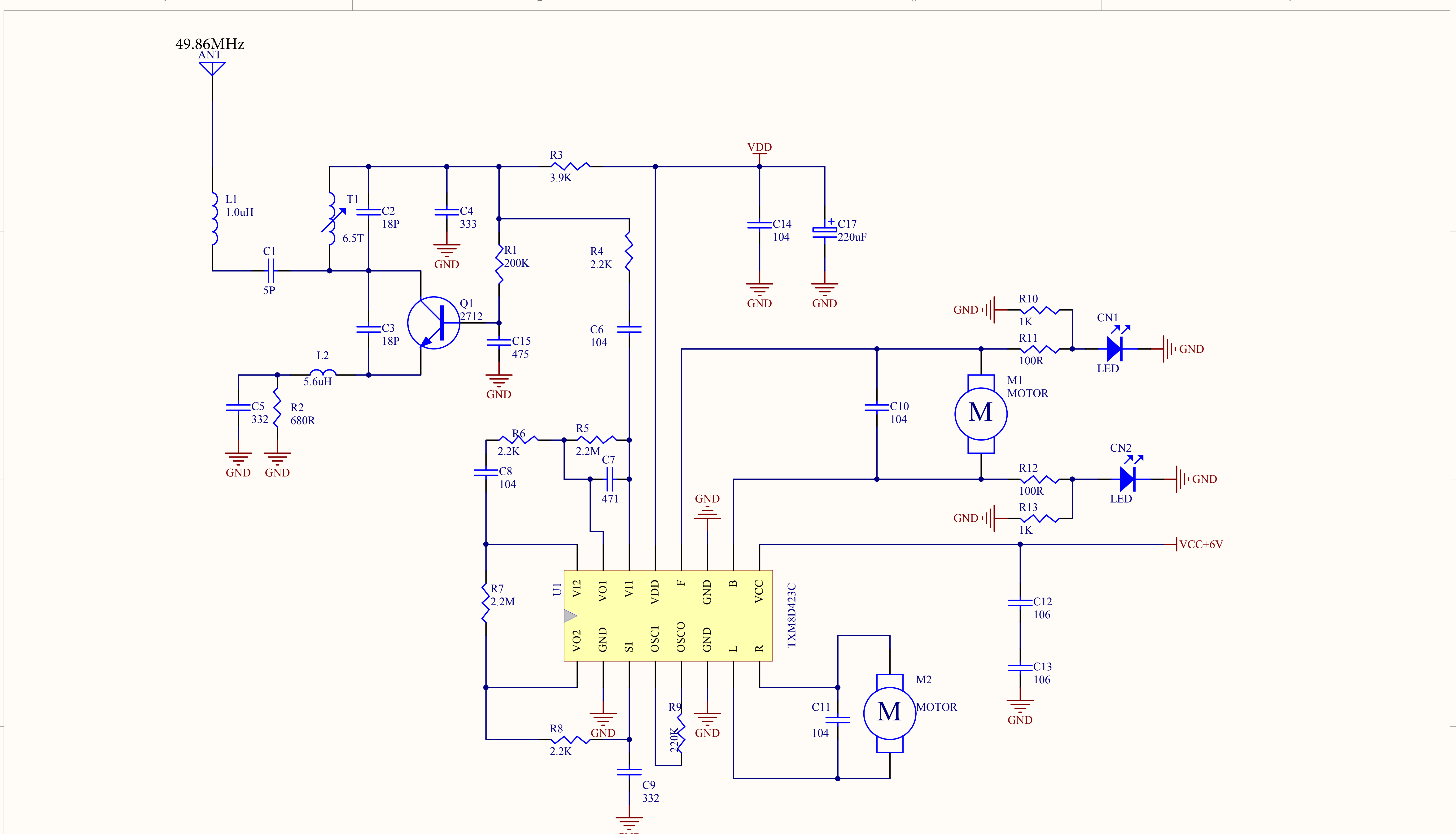
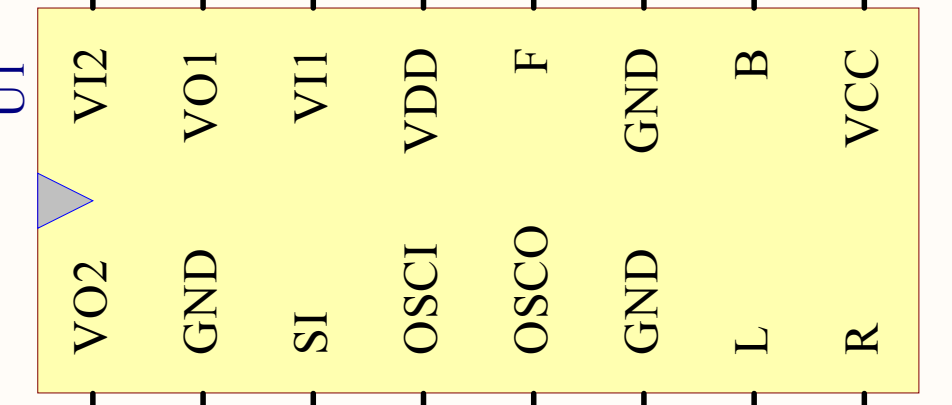

Title		
Size A4	Number LYB803R-49M	Revision
Date: 2017-12-05	Sheet of	
File: E:\Altium Designer	\.\LYB803R-49M.SchDoc	