

TEST REPORT

Report No.: 20061024HKG-001

Kidztech Toys Manufacturing Ltd.

Application For Certification
(Original Grant)

FCC ID: OTM-8501220-27MTX

Transmitter

Prepared and Checked by:

Approved by:

Signed On File
Lee For Yiu, Florey
Assistant Engineer

Wong Kwok Yeung, Kenneth
Senior Lead Engineer
Date: July 13, 2020

Intertek's standard Terms and Conditions can be obtained at our website <http://www.intertek.com/terms/>.

The test report only allows to be revised within the retention period unless further standard or the requirement was noticed.

This report is for the exclusive use of Intertek's Client and is provided pursuant to the agreement between Intertek and its Client. Intertek's responsibility and liability are limited to the terms and conditions of the agreement. Intertek assumes no liability to any party, other than to the Client in accordance with the agreement, for any loss, expense or damage occasioned by the use of this report. Only the Client is authorized to permit copying or distribution of this report and then only in its entirety. Any use of the Intertek name or one of its marks for the sale or advertisement of the tested material, product or service must first be approved in writing by Intertek. The observations and test results in this report are relevant only to the sample tested. This report by itself does not imply that the material, product, or service is or has ever been under an Intertek certification program.

© 2017 Intertek

TEST REPORT

GENERAL INFORMATION

Grantee:	Kidztech Toys Manufacturing Ltd.
Grantee Address:	Room 1201, 12/F., Inter-Continental Plaza, 94 Granville Road, Tsim Sha Tsui East, Kowloon, Hong Kong.
Contact Person:	Eric Ho
Tel:	(852) 2721 8868
Fax:	(852) 2721 8838
e-mail:	N/A
Manufacturer:	Kidztech Intelligent Technology Co., Ltd.
Manufacturer Address:	Chengyang Guang Road, Ancheng Road, Liangxia Town, Chenghai District, Shantou City, 515800, Guangdong, China
Brand Name:	Kidztech Toys
Model:	85012
Additional Model:	85013, 85376, 85476, 85576, 5F633FA, FL02520, 119466
Type of EUT:	Transmitter
Description of EUT:	1/16 R/C Big Foot Off-Road Truck (85012), 1/16 R/C Big Foot Off-Road Truck, 1/16 R/C Off-Road Truck, 1:16 TRUCK ASST. F150 JEEP (85013, 85376, 85476, 85576, 5F633FA, FL02520, 119466)
Serial Number:	N/A
FCC ID:	OTM-8501220-27MTX
Date of Sample Submitted:	June 17, 2020
Date of Test:	June 17, 2020 to July 02, 2020
Report No.:	20061024HKG-001
Report Date:	July 13, 2020
Environmental Conditions:	Temperature: +10 to 40°C Humidity: 10 to 90%
Conclusion:	Test was conducted by client submitted sample. The submitted sample as received complied with the 47 CFR Part 15 Certification.

TEST REPORT

SUMMARY OF TEST RESULT

Test Specification	Reference	Results
Transmitter Field Strength	15.227	Pass

The equipment under test is found to be complying with the following standards:
FCC Part 15, October 1, 2019 Edition

- Note:
1. The EUT uses a permanently attached antenna which, in accordance to section 15.203, is considered sufficient to comply with the pervisions of this section.
 2. Pursuant to FCC part 15 Section 15.215(c), the 20 dB bandwidth of the emission was contained within the frequency band designated (mentioned as above) which the EUT operated. The effects, if any, from frequency sweeping, frequency hopping, other modulation techniques and frequency stability over excepted variations in temperature and supply voltage were considered.

TEST REPORT

TABLE OF CONTENTS

1.0 GENERAL DESCRIPTION 5

1.1 Product Description5

1.2 Related Submittal(s) Grants5

1.3 Test Methodology.....5

1.4 Test Facility5

2.0 SYSTEM TEST CONFIGURATION..... 6

2.1 Justification.....6

2.2 EUT Exercising Software.....6

2.3 Special Accessories6

2.4 Measurement Uncertainty.....6

2.5 Support Equipment List and Description.....6

3.0 EMISSION RESULTS..... 7

3.1 Field Strength Calculation7

3.2 Radiated Emission Configuration Photograph.....8

3.3 Radiated Emission Data8

4.0 EQUIPMENT PHOTOGRAPHS 10

5.0 PRODUCT LABELLING..... 10

6.0 TECHNICAL SPECIFICATIONS 10

7.0 INSTRUCTION MANUAL..... 10

8.0 MISCELLANEOUS INFORMATION 11

8.1 Measured Bandwidth11

8.2 Discussion of Pulse Desensitization.....12

8.3 Calculation of Average Factor12

8.4 Emissions Test Procedures.....12

9.0 EQUIPMENT LIST..... 15

TEST REPORT

1.0 GENERAL DESCRIPTION

1.1 Product Description

The Equipment Under Test (EUT) is portable controller for Remote controlled car set which operates at 27.145MHz. The EUT is power by 1 x 9.0V Alkaline battery.

After switching on the EUT, the car will be moved forward or backward, turned left or right based on the joystick control in the controller.

The Models: 85013, 85376, 85476, 85576, 5F633FA, FL02520 and 119466 are the same as the Model: 85012 in hardware aspect as declared by client. The models are different in non-conductive outer casing of corresponding car only as declared by client.

Antenna Type: Internal, Integral

For electronic filing, the brief circuit description is saved with filename: descri.pdf.

1.2 Related Submittal(s) Grants

This is a single application for certification of a transmitter.

1.3 Test Methodology

Radiated emission measurements were performed according to the procedures in ANSI C63.10 (2013). All radiated measurements were performed in an 3m Chamber. Preliminary scans were performed in the 3m Chamber only to determine worst case modes. All radiated tests were performed at an antenna to EUT distance of 3 meters, unless stated otherwise in the “**Justification Section**” of this Application.

1.4 Test Facility

The 3m Chamber used to collect the radiated data is located at Workshop No. 3, G/F., World-Wide Industrial Centre, 43-47 Shan Mei Street, Fo Tan, Sha Tin, N.T., Hong Kong SAR, China. This test facility and site measurement data have been placed on file with the FCC.

TEST REPORT

2.0 SYSTEM TEST CONFIGURATION

2.1 Justification

The system was configured for testing in a typical fashion (as a customer would normally use it), and in the confines as outlined in ANSI C63.10 (2013).

The device was powered by new DC 9.0V (1 x 9.0V Alkaline Battery).

For maximizing emissions below 30 MHz, the EUT was rotated through 360°, the centre of the loop antenna was placed 1 meter above the ground, and the antenna polarization was changed. For maximizing emission at and above 30 MHz, the EUT was rotated through 360°, the antenna height was varied from 1 meter to 4 meters above the ground plane, and the antenna polarization was changed. This step by step procedure for maximizing emissions led to the data report in Exhibit 3.0.

The unit was operated standalone and placed in the center of the turntable.

The equipment under test (EUT) was configured for testing in a typical fashion (as a customer would normally use it). The EUT was mounted to a plastic stand if necessary and placed on the wooden turntable, which enabled the engineer to maximize emissions through its placement in the three orthogonal axes.

2.2 EUT Exercising Software

There was no special software to exercise the device. Once the unit is powered up, it transmits the RF signal continuously.

2.3 Special Accessories

There are no special accessories necessary for compliance of this product.

2.4 Measurement Uncertainty

When determining of the test conclusion, the Measurement Uncertainty of test has been considered.

2.5 Support Equipment List and Description

N/A.

TEST REPORT

3.0 EMISSION RESULTS

Data is included of the worst case configuration (the configuration which resulted in the highest emission levels). A sample calculation, configuration photographs and data tables of the emissions are included.

3.1 Field Strength Calculation

The field strength is calculated by adding the Antenna Factor and Cable Factor, and subtracting the Amplifier Gain (if any), Average Factor (optional) from the measured reading. The basic equation with a sample calculation is as follows:

$$FS = RA + AF + CF - AG - AV$$

where FS = Field Strength in dB μ V/m

RA = Receiver Amplitude (including preamplifier) in dB μ V

CF = Cable Attenuation Factor in dB

AF = Antenna Factor in dB

AG = Amplifier Gain in dB

AV = Average Factor in dB

In the following table(s), the reading shown on the data table reflects the preamplifier gain. An example for the calculations in the following table is as follows:

$$FS = RR + LF$$

where FS = Field Strength in dB μ V/m

RR = RA - AG - AV in dB μ V

LF = CF + AF in dB

Assume a receiver reading of 52.0 dB μ V is obtained. The antenna factor of 7.4 dB and cable factor of 1.6 dB are added. The amplifier gain of 29 dB and average factor of 5 dB are subtracted, giving a field strength of 27 dB μ V/m. This value in dB μ V/m was converted to its corresponding level in μ V/m.

$$RA = 52.0 \text{ dB}\mu\text{V/m}$$

$$AF = 7.4 \text{ dB}$$

$$CF = 1.6 \text{ dB}$$

$$AG = 29.0 \text{ dB}$$

$$AV = 5.0 \text{ dB}$$

$$FS = RR + LF$$

$$FS = 18 + 9 = 27 \text{ dB}\mu\text{V/m}$$

$$RR = 18.0 \text{ dB}\mu\text{V}$$

$$LF = 9.0 \text{ dB}$$

$$\text{Level in } \mu\text{V/m} = \text{Common Antilogarithm } [(27 \text{ dB}\mu\text{V/m})/20] = 22.4 \mu\text{V/m}$$

TEST REPORT

3.2 Radiated Emission Configuration Photograph

The worst case in radiated emission was found at 569.781 MHz

For electronic filing, the worst case radiated emission configuration photographs are saved with filename: radiated photos.pdf.

3.3 Radiated Emission Data

The data on the following page lists the significant emission frequencies, the limit and the margin of compliance. Numbers with a minus sign are below the limit.

Judgment: Passed by 19.4 dB

TEST REPORT

RADIATED EMISSIONS

Model: 85012

Date of Test: July 02, 2020

Worst-Case Operating Mode: Transmitting

Table 1
Pursuant to FCC Part 15 Section 15.227 Requirement

Polarization	Frequency (MHz)	Reading (dBµV)	Pre-Amp (dB)	Antenna Factor (dB)	Average Factor (dB)	Net at 3m (dBµV/m)	Limit at 3m (dBµV/m)	Margin (dB)
V	27.146	59.5	16	15.4	0.0	58.9	80.0	-21.1
V	54.250	25.4	16	11.0	-	20.4	40.0	-19.6
V	81.428	18.2	16	7.0	-	9.2	40.0	-30.8
H	106.778	16.6	16	13.0	-	13.6	43.5	-29.9
V	108.580	11.8	16	14.0	-	9.8	43.5	-33.7
V	135.725	24.1	16	14.0	-	22.1	43.5	-21.4
V	150.409	20.8	16	14.0	-	18.8	43.5	-24.7
H	162.870	12.3	16	16.0	-	12.3	43.5	-31.2
H	190.015	13.7	16	16.0	-	13.7	43.5	-29.8
V	219.513	14.8	16	17.0	-	15.8	46.0	-30.2
V	244.305	11.2	16	20.0	-	15.2	46.0	-30.8
V	271.450	9.6	16	22.0	-	15.6	46.0	-30.4
V	395.988	11.9	16	25.0	-	20.9	46.0	-25.1
H	569.781	14.6	16	28.0	-	26.6	46.0	-19.4

- NOTES:
1. Peak Detector Data unless otherwise stated.
 2. All measurements were made at 3 meters.
 3. Negative sign in the column shows value below limit.
 4. Loop antenna is used for the emissions below 30MHz.
 5. Emission (the row indicated by **bold italic**) within the restricted band meets the requirement of FCC Part 15 Section 15.205.
 6. Measurement Uncertainty is ±5.3dB at a level of confidence of 95%.

TEST REPORT

4.0 EQUIPMENT PHOTOGRAPHS

For electronic filing, the photographs are saved with filename: external photos.pdf and internal photos.pdf.

5.0 PRODUCT LABELLING

For electronics filing, the FCC ID label artwork and the label location are saved with filename: label.pdf.

6.0 TECHNICAL SPECIFICATIONS

For electronic filing, the block diagram and schematic of the tested EUT are saved with filename: block.pdf and circuit.pdf respectively.

7.0 INSTRUCTION MANUAL

For electronic filing, a preliminary copy of the Instruction Manual is saved with filename: manual.pdf.

This manual will be provided to the end-user with each unit sold/leased in the United States.

TEST REPORT

8.0 MISCELLANEOUS INFORMATION

The miscellaneous information includes details of the test procedure and measured bandwidth.

8.1 Measured Bandwidth

The plot shows the fundamental emission is confined in the specified band. And it also shows that the emission is at least 37.78 dB below the carrier level at the band edge (26.96 and 27.28 MHz). It meets the requirement of Section 15.227(b).

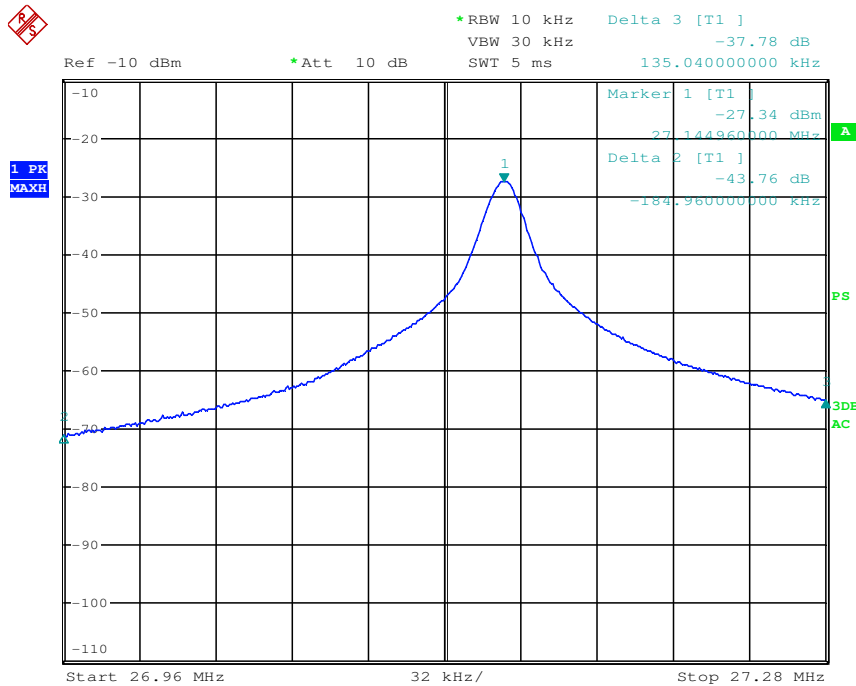

TEST REPORT

8.2 Discussion of Pulse Desensitization

Pulse desensitivity is not applicable for this device. Since the transmitter transmits the RF signal continuously.

8.3 Calculation of Average Factor

It is not necessary to apply average factor as the measured (peak) data has been complied with average limit of the radiated emission.

8.4 Emissions Test Procedures

The following is a description of the test procedure used by Intertek Testing Services Hong Kong Ltd. in the measurements of transmitter operating under the Part 15, Subpart C rules.

The transmitting equipment under test (EUT) is placed on a wooden turntable which is four feet in diameter and approximately 0.8m in height above the ground plane for emission measurement at or below 1GHz and 1.5m in height above the ground plane for emission measurement above 1GHz. During the radiated emissions test, the turntable is rotated and any cables leaving the EUT are manipulated to find the configuration resulting in maximum emissions. The EUT is adjusted through all three orthogonal axis to obtain maximum emission levels. The antenna height and polarization are also varied during the testing to search for maximum signal levels. The height of the antenna is varied from one to four meters.

Detector function for radiated emissions is in peak mode. Average readings, when required, are taken by measuring the duty cycle of the equipment under test and subtracting the corresponding amount in dB from the measured peak readings. A detailed description for the calculation of the average factor can be found in Exhibit 8.3.

The frequency range scanned is from the lowest radio frequency signal generated in the device which is greater than 9 kHz to the tenth harmonic of the highest fundamental frequency or 40 GHz, whichever is lower.

TEST REPORT

8.4 Emissions Test Procedures (cont'd)

The EUT is warmed up for 15 minutes prior to the test.

AC power to the unit is varied from 85% to 115% nominal and variation in the fundamental emission field strength is recorded. If battery powered, a new, fully charged battery is used.

Conducted measurements were made as described in ANSI C63.10 (2013).

The IF bandwidth used for measurement of radiated signal strength was 100 kHz or greater when frequency is below 1000 MHz. Where pulsed transmissions of short enough pulse duration warrant, a greater bandwidth is selected according to the recommendations of Hewlett Packard Application Note 150-2. A discussion of whether pulse desensitivity is applicable to this unit is included in this report (See Exhibit 8.1). Above 1000 MHz, a resolution bandwidth of 3 MHz is used.

Transmitter measurements are normally conducted at a measurement distance of three meters. However, to assure low enough noise floor in the forbidden bands and above 1 GHz, signals are acquired at a distance of one meter or less. All measurements are extrapolated to three meters using inverse scaling, unless otherwise reported. Measurements taken at a closer distance are so marked.

TEST REPORT

8.4.1 Radiated Emission Test Setup

The figure below shows the test setup, which is utilized to make these measurements.

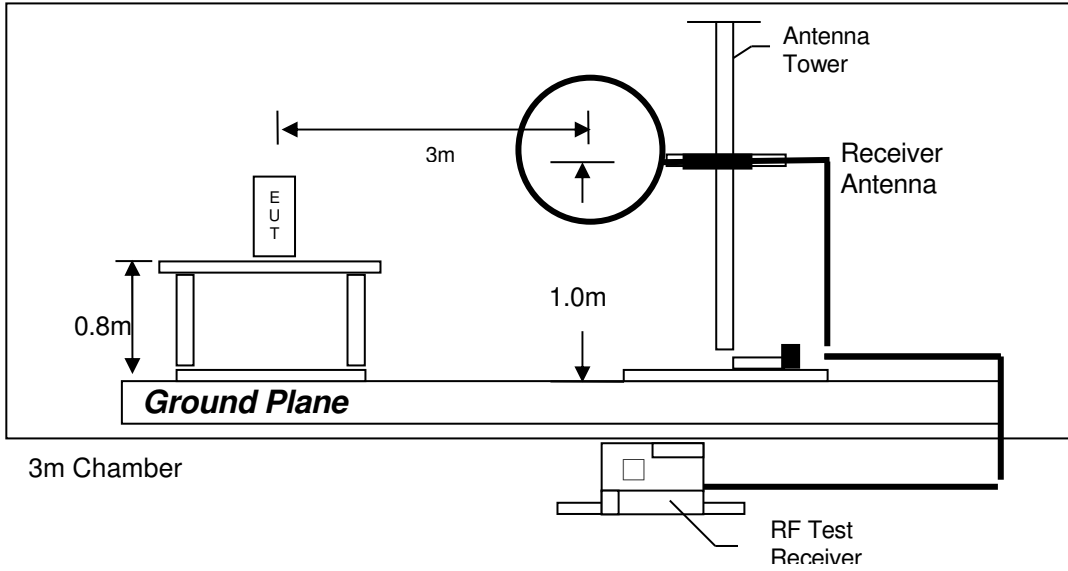

Test setup of radiated emissions up to 30MHz

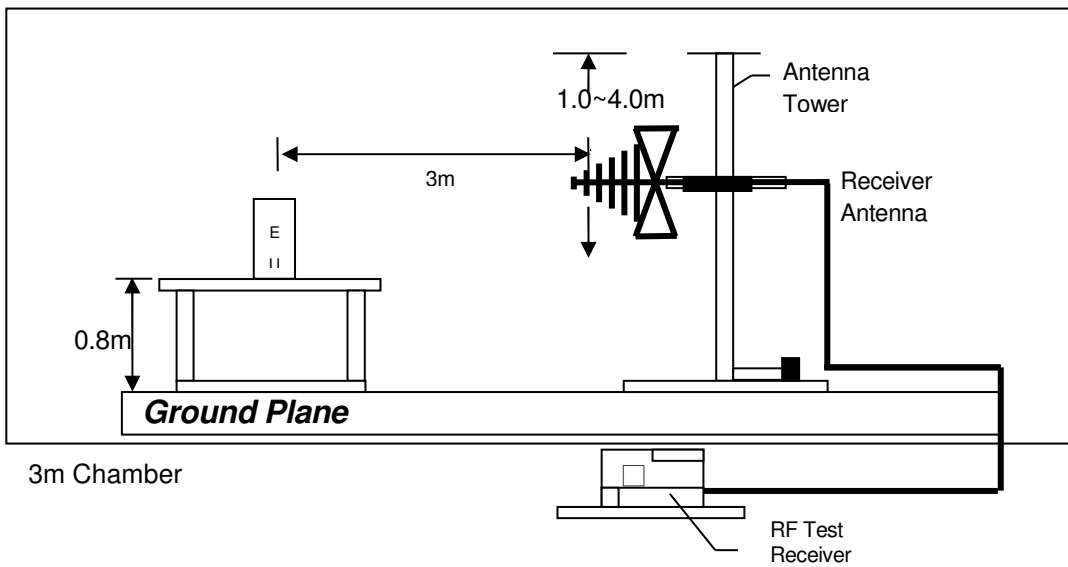

Test setup of radiated emissions below 1GHz

TEST REPORT

9.0 EQUIPMENT LIST

1) Radiated Emissions Test

Equipment	Test Receiver	Biconical Antenna	Log Periodic Antenna
Registration No.	EW-3156	EW-0571	EW-1042
Manufacturer	ROHDESCHWARZ	EMCO	EMCO
Model No.	ESR26	3104C	3148
Calibration Date	August 01, 2019	July 23, 2019	November 23, 2018
Calibration Due Date	August 01, 2020	January 23, 2021	November 23, 2020

Equipment	14m Double Shield RF Cable (20MHz - 6GHz)	Active Loop H-field (9kHz to 30MHz)
Registration No.	EW-2505	EW-3326
Manufacturer	RADIALL	EMCO
Model No.	Br5d	6502
Calibration Date	November 14, 2019	September 21, 2019
Calibration Due Date	November 14, 2020	September 21, 2020

2) Bandwidth Measurement

Equipment	Spectrum Analyzer
Registration No.	EW-3281
Manufacturer	ROHDESCHWARZ
Model No.	FSV40
Calibration Date	March 04, 2020
Calibration Due Date	March 04, 2021

END OF TEST REPORT