

FCC COMPLIANCE REPORT

Order No. : STR-05-0068/E
Reference No. : F690501/LF-EMC000965
Applicant : Omron Automotive Electronics Korea Co., Ltd.
Address of Applicant : 481-2, Kasan-Dong, Kumchun-Ku, Seoul, 153-023, Korea

Equipment Under Test (EUT) :

Name : RF Keyless Entry System (Receiver)
Model No. : OKA-750R

Standards : FCC Part 15, Subpart B, Class B
ANSI C63.4:1992

Date of Receipt : 01 April 2005
Date of Test : 06 April 2005
Date of Issue : 07 April 2005

Test Result :	PASS
----------------------	-------------

In the configuration tested, the EUT complied with the standards specified above.

Remarks :

This report details the results of the testing carried out on one sample, the results contained in this test report do not relate to other samples of the same product. The manufacturer should ensure that all products in series production are in conformity with the product sample detailed in this report.

This report shall not be reproduced except in full, without the written approval of the laboratory. If the product in this report is used in any configuration other than that detailed in the report, the manufacturer must ensure the new system complies with all relevant standards.



Kew-Seung, Lim
EMC DIV. Manager
SGS Testing Korea CO., LTD.

Contents

1. General Information

1.1 Manufacturer Information.....	4
1.2 General Description of EUT.....	4
1.3 Details of EUT.....	4
1.4 Description of Support Units.....	4
1.5 Cable List.....	5
1.6 System Configuration.....	5
1.7 Test Set-Up Configuration.....	5
1.8 Measurement Procedure.....	6
1.9 Standards Applicable for Testing.....	6
1.10 Summary of Results.....	6

2. Measurement Results

2.1 Applied Tests.....	7
2.2 Frequency Range.....	7
2.3 Limit Of Radiated Emission.....	7
2.3.1 Limit Of Radiated Emission Of RSS-210, Table 3.....	7
2.3.2 Limit Of Radiated Emission Of RSS-210, Table 7.....	7
2.4 Test of Conducted Emission.....	8
2.4.1 Test Instruments.....	8
2.4.2 Test Site.....	8
2.4.3 Operating Environment.....	8
2.4.4 Measurement Data.....	8
2.5 Test of Radiated Emission.....	9
2.5.1 Test Instruments.....	9
2.5.2 Test Site.....	9
2.5.3 Operating Environment.....	9
2.5.4 Measurement Data.....	9

3. Photographs of Test.....	10
------------------------------------	-----------

4. Photographs of Product.....	12
---------------------------------------	-----------

1. General Information

1.1 Manufacturer Information

Manufacturer : Omron Automotive Electronics Korea Co., Ltd.
 Address : 481-2, Kasan-Dong, Kumchun-Ku, Seoul, 153-023, Korea

1.2 General Description of EUT

Name : RF Keyless Entry System (Receiver)
 Model No. : OKA-750R
 Serial No : None
 FCC ID : OSLOKA-750RN
 Modulation : FSK

1.3 Details of EUT

Operating Frequency : 313.85 MHz
 Tested Power Supply : DC 12V
 Port : I/O 1, I/O 2, I/O 3, I/O 4, ANT
 Description of Operating : Operate it continually.
 Modifications to the EUT : None

1.4 Description of Support Units

Product	Model No.	Serial No.	Manufacturer
RF Keyless Entry System (Receiver)	OKA-750R	N/A	Omron Automotive Electronics Korea Co., Ltd.
Checker	N/A	N/A	Omron Automotive Electronics Korea Co., Ltd.
RF Keyless Entry System (Transmitter)	N/A	N/A	Omron Automotive Electronics Korea Co., Ltd.

1.5 Cable List

Start		END		Cable Spec	
Name	I/O Port	Name	I/O Port	Length	Shield
EUT	I/O 2	Checker	Output	2.0	Unshielded
	I/O 3	Checker	Output	2.0	Unshielded
	ANT	Antenna	-	0.1	Shielded

1.6 System Configuration

Description	Model	Serial No.	Manufacturer
Main Board	MG-ETACS	N/A	N/A
RF Module	N/A	N/A	N/A

1.7 Test Set-Up Configuration

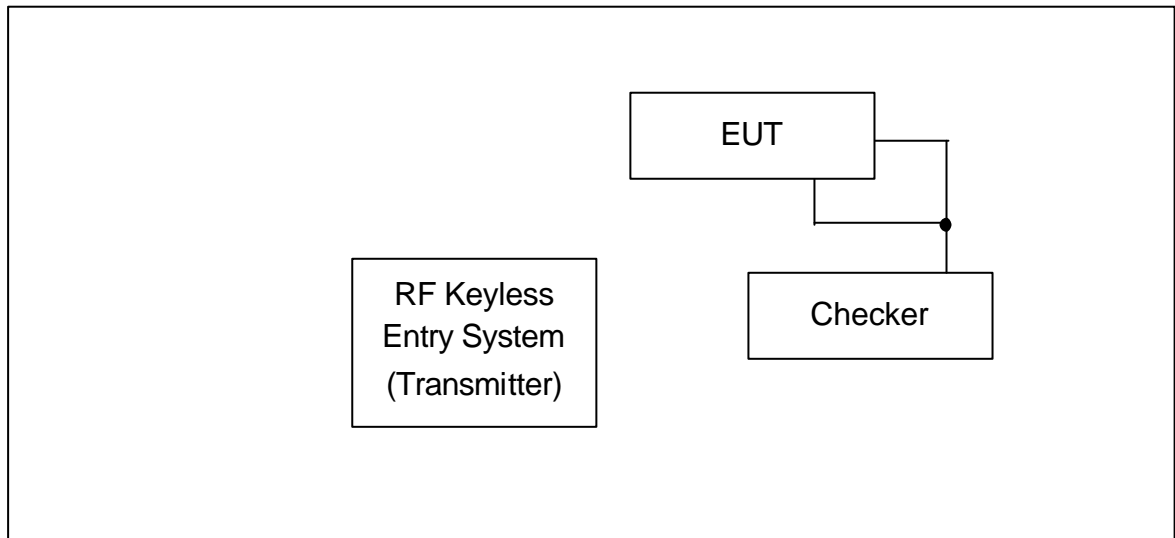

1.8 Measurement Procedure

Conducted Emission Testing was performed according ANSI C63.4:1992 in a shielded room with peripherals placed on a table, 0.8m high over a metal floor. It was located more than required distance away from the shielded room wall.

Radiated Emission Testing was performed according to ANSI C63.4:1992 at the open field test site. The EUT was placed in a 0.8m high table along with the peripherals. The turn table was separated from the antenna distance 3meters. Cables were placed in a position to produce maximum emissions as determined by experimentation, and operation mode was selected for maximum.

The frequencies and amplitudes of maximum emission were measured at varying azimuths, antenna heights and antenna polarities. Reported are maximized emission levels.

1.9 Standards Applicable for Testing

Table of tests to be carried out under FCC Part 15, Subpart B, CLASS B

Test Standards	Status
FCC Part 15,Subpart B, Class B	Applicable
Deviation from Standard	No Deviation

1.10 Summary of Results

The data collected shows that Model **OKA-750R** complies with Part 15.109 of FCC Technical Rules. The highest emission level observed was at 941.55MHz radiated emission with a margin of 4.48dB.

Radio Disturbance

2.1 Test Results

	Results
Conducted Emission	N/A
Radiated Emission	PASS

2.2 Frequency Range

Conducted Emission : 150 kHz - 30 MHz

Radiated Emission : 30 MHz - 1000 MHz, Above 1000MHz

2.3 Limits Of Conducted And Radiated Emission

2.3.1 Limit Of Conducted Emission Of FCC Part 15, Subpart B

FREQUENCY (MHz)	Class A	Class B
	Quasi - peak	Quasi - peak
0.45 – 1.705	1000uV(60dB)	250uV(48dB)
1.705 - 30.0	3000uV(69.5dB)	250uV(48dB)

2.3.2 Limit Of Radiated Emission Of FCC Part 15, Subpart B

FREQUENCY (MHz)	Class A (at 10m)*	Class B (at 3m)*
	uV/m(dBuV/m)	uV/m(dBuV/m)
30 - 88	90(39)	100(40)
88 - 216	150(43.5)	150(43.5)
216 - 960	210(46.4)	200(46)
Above 960	300(49.5)	500(54)

Note : (1) *Detector Function : Quasi-Peak

(2) The lower limit shall apply at the transition frequencies.

(3) Emission level (dBuV/m) = 20 log Emission level (uV/m).

(4) All emanation from a class A/B digital device or system, including anynetwork of conductors and apparatus connected thereto, shall not exceed the level of field strengths specified above.

2.4. Test of Conducted Emission

2.4.1 Test Equipments

Equipment	Model No.	Manufacturer	Date of Calibration
Test Receiver	ESPC	R/S	Nov. 2004
LISN	3825/2	EMCO	Dec. 2004
Pulse Limiter	PL-01	PMM	Jul. 2004
Shield Room	3.0*6.0*2.5	Dail EMC	N/A

2.4.2 Test Site

Name and address : SGS Testing Korea Co., Ltd.
 18-34, Sanbon-dong, Gunpo, Gyeonggi-do, Korea, 435-041

2.4.3 Operating Environment

Temperature : degree C Humidity : %RH
 Atmospheric Pressure : mBar

2.4.4 Measurement Data

Measurement Bandwidth : 9kHz

Date of Test :

FREQ. (MHz)	LEVEL(dB μ V)		LINE	LIMIT(dB μ V)		MARGIN(dB μ V)	
	Q-Peak	Average		Q-Peak	Average	Q-Peak	Average

Note : This test item is not applied because this product is supplied DC Power from Car Battery.



See - Ho, Lee / Test Engineer

2.5 Test of Radiated Emission**2.5.1 Test Instruments**

Description	Model No.	Manufacturer	Date of Calibration
Test Receiver	ESVS 30	R & S	Jan. 2005
Spectrum Analyzer	E4411A	H.P	Oct. 2004
RF Amplifier	8447F	H.P	May. 2004
Horn Antenna	BBHA 9120D	Scaffner	May. 2004
Bilog Antenna	CBL6111C	Scaffner	Apr. 2004
RF Select s/w	CS201	DAIWA	Apr. 2004
Open Site	N/A	N/A	Mar. 2005
Spectrum Analyzer	8593E	Scaffner	Aug. 2004
RF Amplifier	8449B	H.P	May. 2004

2.5.2 Test Site

Name and address : SGS Testing Korea Co., Ltd.

18-34, Sanbon-dong, Gunpo, Gyeonggi-do, Korea, 435-041

2.5.3 Operating Environment

Temperature : 11.8 degree C

Humidity : 39 %RH

Atmospheric Pressure : 1003 mBar

2.5.4 Measurement Data

Measurement Bandwidth : 100kHz

Date of Test : April 06, 2005

FREQ. (kHz)	LEVEL (dB μ V)	POL (H/V)	*AF (dB)	**CL (dB)	F/S (dB μ V/m)	LIMIT (dB)	***MARGIN (dB)
313.85	6.7	H	13.47	4.57	24.74	46.00	21.26
627.70	7.1	H	21.55	7.54	36.19	46.00	9.81
941.55	6.2	H	26.27	9.06	41.52	46.00	4.48
1255.40	5.8	H	29.27	5.90	40.97	54.00	13.03
1569.25	6.1	H	29.27	5.90	41.27	54.00	12.73
1883.10	5.2	H	29.27	5.90	40.37	54.00	13.63

* AF = Antenna Factor. ** CL = Cable Loss.

*** Margin=Each Frequency Limit Level(dBuV) - (Level+AF+CL)

**** The Limit is translated from 300m/30m Value to 3m.



See -Ho, Lee / Test Engineer

3. Photographs of Test

- Front View of Conducted Emission

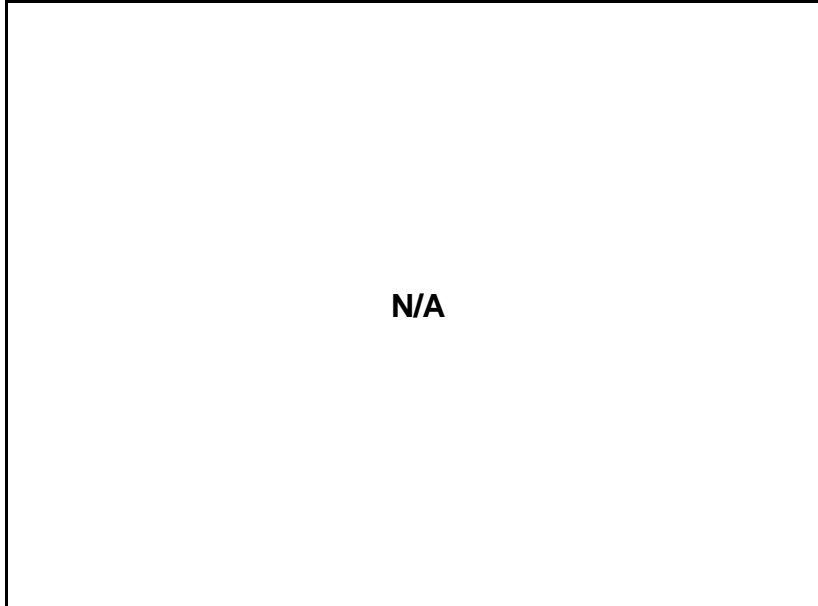

- Rear View of Conducted Emission

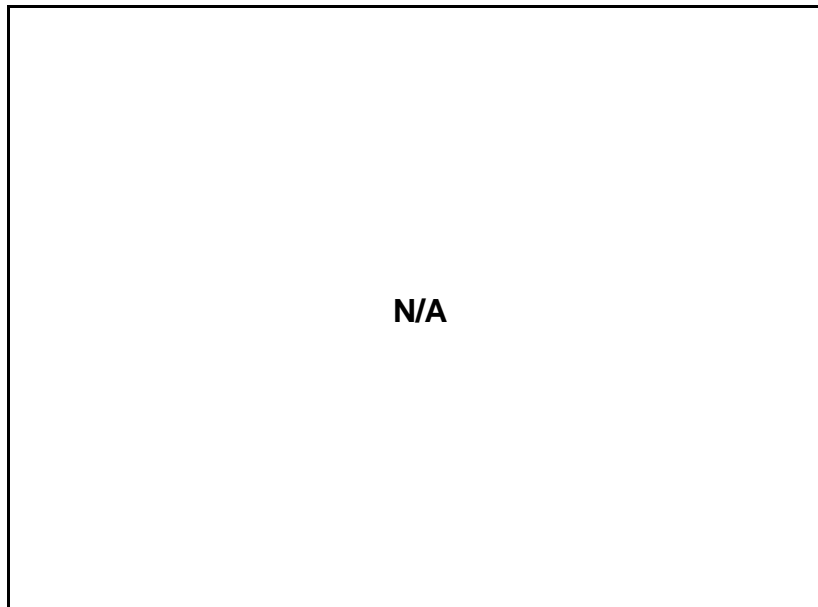

- Front View of Radiated Emission



- Rear View of Radiated Emission

