

OMRON
AUTOMOTIVE ELECTRONICS
KOREA

OKA - 642T

Transmitter, RF Keyless Entry System

Table of contents

1.	Constitution of the RF Keyless Entry system Controllerfor vehicle	1
2.	User's manual (provisionally)	2
3.	Block diagram	3
4.	Specification	4
5.	Features	5
6.	PCB	6
6.1	Circuit diagram	6
6.2	Parts layout	7
6.3	Parts list	10
7.	Photographs	11

This device complies with part 15 of the FCC Rules. Operation is subject to the following two conditions:
(1) This device may not cause harmful interference, and
(2) This device must accept any interference received, including interference that may cause undesired operation.

Caution :
Any changes or modifications to the equipment not expressly approved by the party responsible for compliance could void user § authority to operate the equipment.

1. Constitution of the Radio Frequency Keyless Entry System for vehicle

The radio frequency keyless entry is a system that it controls locking and unlocking the door and the trunk by wireless remote controller. This system consists of three components. The TRANSMITTER is a device that transmits the signal when the button is pressed. The transmission signal consists of several synchronous codes, unique identification code, security code and function code. The RECEIVER is fixed inside the vehicle. It works intermittently to prevent the battery exhaustion.

When the receiver detects the synchronous code, it runs continuously to receive the signals completely. After receiving the signal, the receiver decides which operation will be performed. The remote user can select the following operations by pressing the button of the transmitter.

OPERATION	ACTION
LOCK	lock the door
UNLOCK	unlock the door

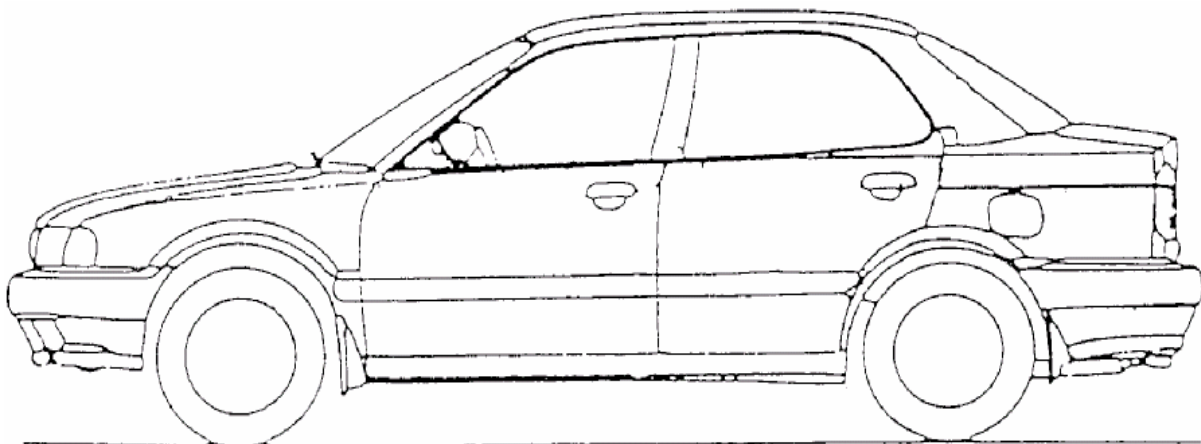

Transmitter
 $f = 307.9\text{MHz}$



2. User's manual (provisionally)

REMOTE TRANSMITTER

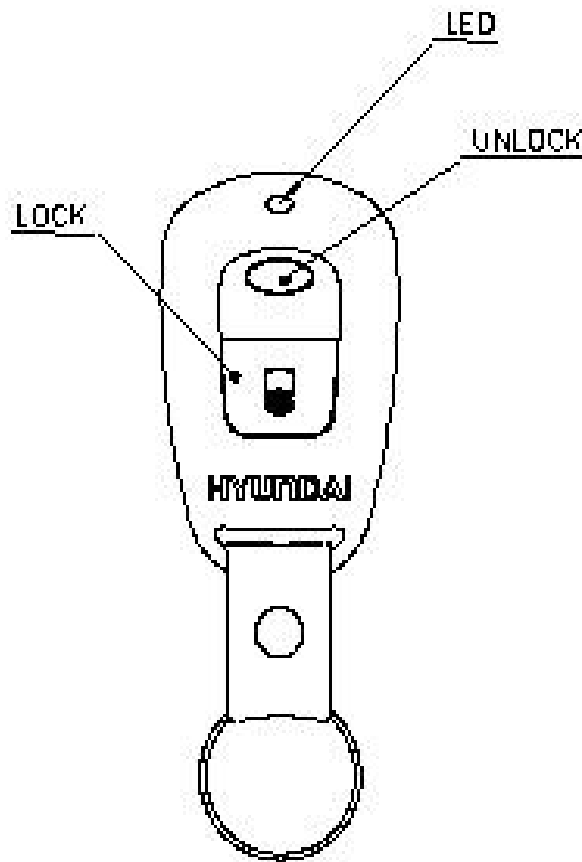

You can lock and unlock your vehicle with the remote transmitter.

LOCK

When you push the LOCK button, all the doors will lock.

You cannot lock any of the doors with the remote transmitter if any door is open or the key is in the ignition switch.

UNLOCK

When you push the UNLOCK button, all the doors will unlock.

You cannot unlock any of the doors with the remote transmitter if any door is open or the key is in the ignition switch.

3. Block diagram

This is block diagram concerning to the transmitter

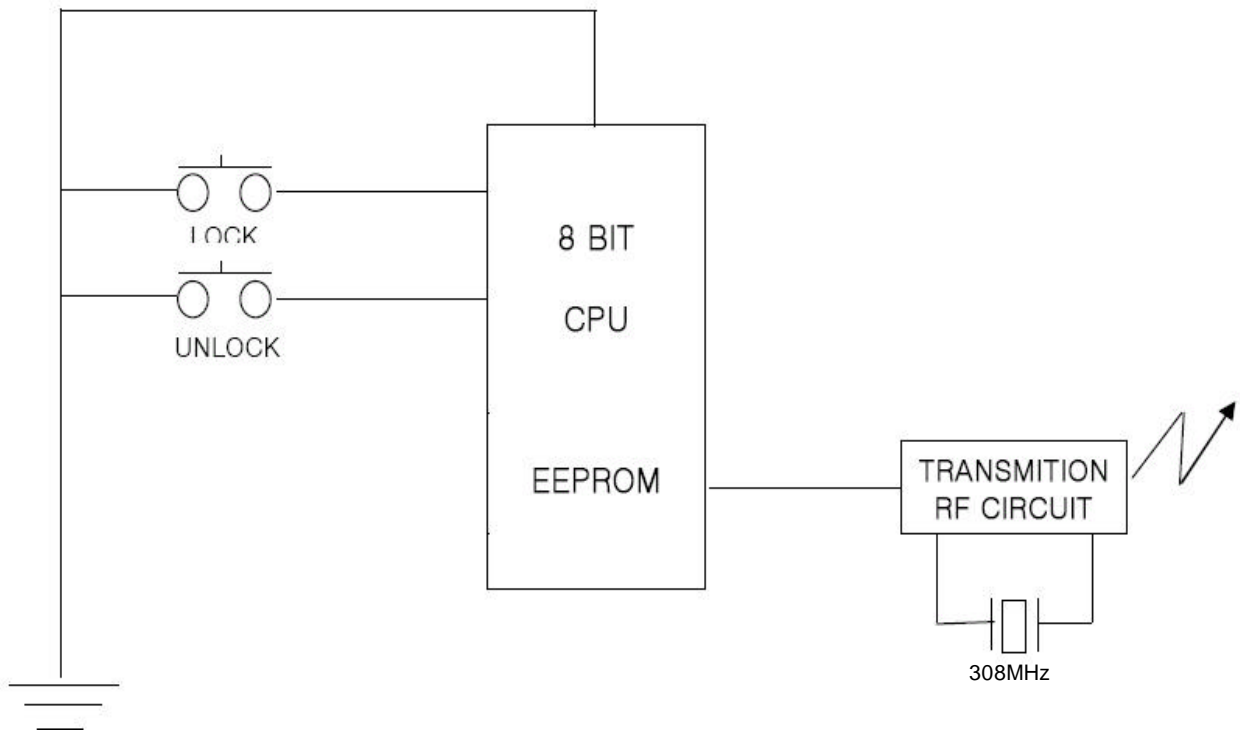

figure 3.1 block diagram of the transmitter

4. Specification

4.1 CPU

Type	uPD754144 -xxx(4bit)
	Manufacturer : NEC Corporation
ROM	4096 * 8bit (4 Kbytes)
RAM	128 bytes * 4bit
EEPROM	16 bytes * 8bit
Clock frequency	500KHz
Clock frequency generation	CRYSTAL Osillation
Package	20pin SSOP

4.2 RF block

Carrer frequency	307.9MHz
Frequency generation	SAW resonator
Modulation	FSK
Bit transmission rate	1000bps or 500bps
Bandwidth	120KHz
RF output power(field strength)	4000uV at 3m

4.3 Others

Dimension	52.5mm x33mm x11mm
Weigh	18.67g
Battery	Lithium cell (CR2032)
	Manufacturer : PANASONIC Battery corporation etc.
Operation Voltage	DC3V, 5mA
Operation Temperature	-20 +60

5. Features

5.1 Transmission frame

The transmission begins immediately in case of LOCK and UNLOCK button is pressed. The transmission frame consists of the synchronous frame and the data frame. The synchronous frame has 30 synchronous codes that it will be used for the receiver to wake up. The data frame consists of 24bit length identification code, 16bit security code and function code. 16million different identification codes are available.

The security code is always changed in case of any of the buttons is pressed. The transmission time is typically 640 milliseconds.

5.2 Battery saving

To prevent the battery exhaustion , the micro-computer of the transmitter is usually inactive. When the button will be pressed, the micro-computer wakes up immediately and judges which button is pressing. Then the micro-computer constructs the transmission frame and radiates it from the antenna .After transmitting, the micro-computer switches stand-by mode by itself.