

FCC COMPLIANCE REPORT

Order No. : STR-07-0169/G
Reference No. : STK-07-EMCG0148
Applicant : Omron Automotive Electronics Korea Co., Ltd.
Address of Applicant : Ace Techno 10-cha 701, 470-5, Gasan-Dong,
Gumcheon-gu, Seoul, 153-789, Korea
Manufacturer : Omron Automotive Electronics Korea Co., Ltd.
Address of Manufacturer : 492, Gayul-ri, Bogae-myeon, Anseong-city,
Kyeonggi-do, 456-871, Korea

Equipment Under Test (EUT) :

Name : RF Keyless Entry System (Receiver)
Model No. : OKA-322R
FCC ID : OSLOKA-322R

Standards : FCC Part 15:2005, Subpart B, Class B
ANSI C63.4:2003
CISPR 22:1997
CISPR 16-1:2003

Date of Receipt : 18 June 2007
Date of Test : 25 June 2007
Date of Issue : 05 July 2007

Test Result :	PASS
----------------------	-------------

In the configuration tested, the EUT complied with the standards specified above.

Remarks :

This report details the results of the testing carried out on one sample, the results contained in this test report do not relate to other samples of the same product. The manufacturer should ensure that all products in series production are in conformity with the product sample detailed in this report.

This report shall not be reproduced except in full, without the written approval of the laboratory. If the product in this report is used in any configuration other than that detailed in the report, the manufacturer must ensure the new system complies with all relevant standards.



Jess Kim
EMC DIV. Manager
SGS Testing Korea Co., Ltd.

Contents

1. General Information

1.1 Applicant & Manufacturer Information.....	3
1.2 General Description of EUT.....	3
1.3 Details of EUT.....	3
1.4 Description of Support Units.....	3
1.5 System Configuration.....	3
1.6 Cable List.....	4
1.7 Test Set-Up Configuration.....	4
1.8 Measurement Procedure.....	4
1.9 Standards Applicable for Testing.....	5
1.10 Summary of Results.....	5

2. Radio Disturbance

2.1 Test Results.....	6
2.2 Frequency Range.....	6
2.3 Limit Of Conducted And Radiated Emission.....	6
2.3.1 Limit Of Conducted Emission Of FCC Part 15, Subpart B.....	6
2.3.2 Limit Of Radiated Emission Of FCC Part 15, Subpart B.....	6
2.4 Test of Conducted Emission.....	7
2.4.1 Test Instruments.....	7
2.4.2 Test Site.....	7
2.4.3 Operating Environment.....	7
2.4.4 Measurement Data.....	7
2.5 Test of Radiated Emission.....	8
2.5.1 Test Instruments.....	8
2.5.2 Test Site.....	8
2.5.3 Operating Environment.....	8
2.5.4 Measurement Data.....	8

3. Photographs of Test.....	9-10
------------------------------------	-------------

4. Photographs of Product.....	11-13
---------------------------------------	--------------

1. General Information

1.1 Applicant & Manufacturer Information

Applicant : Omron Automotive Electronics Korea Co., Ltd.
 Address of Applicant : Ace Techno 10-cha 701, 470-5, Gasan-Dong,
 Gumcheon-gu, Seoul, 153-789, Korea
 Manufacturer : Omron Automotive Electronics Korea Co., Ltd.
 Address of Manufacturer : 492, Gayul-ri, Bogae-myeon, Anseong-city,
 Kyeonggi-do, 456-871, Korea

1.2 General Description of EUT

Name : RF Keyless Entry System (Receiver)
 Model No. : OKA-322R
 Serial No : None
 FCC ID : OSLOKA-322R

1.3 Details of EUT

Operating Frequency : 313.85 MHz
 Tested Power Supply : DC 12V
 Port : Power & Signal Port
 Description of Operating : Operate it continually.
 Modifications to the EUT: None

1.4 Description of Support Units

Product	Model No.	Serial No.	Manufacturer
Transmitter	OKA-322T	-	Omron

1.5 System Configuration

Start		END		Cable Spec	
Name	I/O Port	Name	I/O Port	Length	Shield
EUT	-	ZIG	-	1.2	Unshielded
	-	Antenna	-	0.3	Unshielded
	-	Battery	-	0.9	Unshielded

1.6 System Configuration

Description	Model	Serial No.	Manufacturer
Main Board	NF-BCM	-	-

1.7 Test Set-Up Configuration

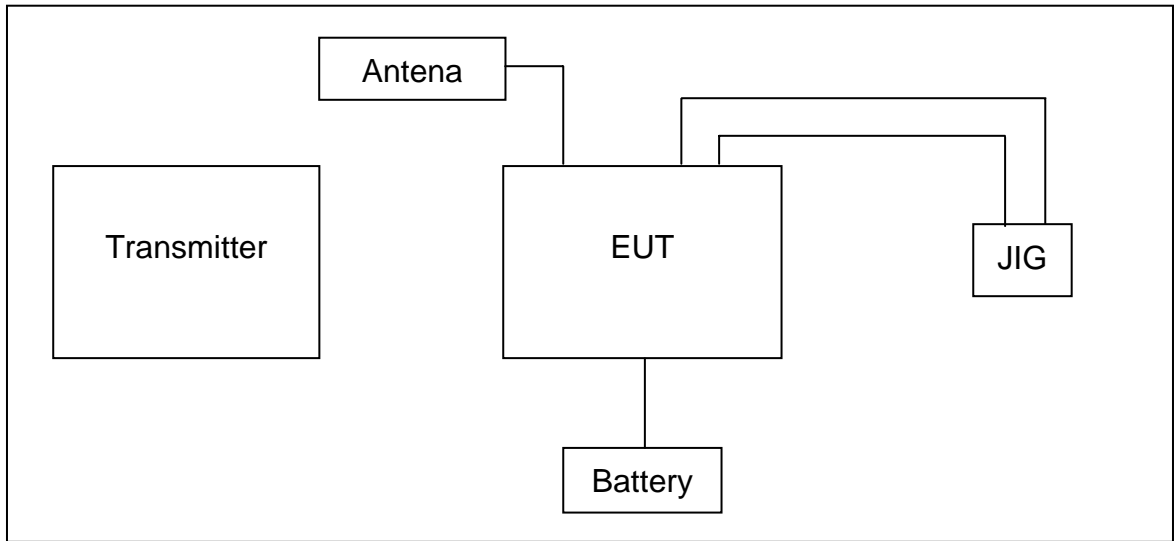

1.8 Measurement Procedure

Conducted Emission Testing was performed according ANSI C63.4:2003 in a shielded room with peripherals placed on a table, 0.8m high over a metal floor. It was located more than required distance away from the shielded room wall. Radiated Emission Testing was performed according to ANSI C63.4:2003 at the open field test site. The EUT was placed in a 0.8m high table along with the peripherals. The turn table was separated from the antenna distance 3meters. Cables were placed in a position to produce maximum emissions as determined by experimentation, and operation mode was selected for maximum. The frequencies and amplitudes of maximum emission were measured at varying azimuths, antenna heights and antenna polarities. Reported are maximized emission levels.

1.9 Standards Applicable for Testing

Table of tests to be carried out under FCC Part 15, Subpart B, CLASS B

Test Standards	Status
FCC Part 15,Subpart B, Class B	Applicable
Deviation from Standard	No Deviation

1.10 Summary of Results

The data collected shows that Model **OKA-322R** complies with Part 15.109 of FCC Technical Rules. The highest emission level observed was at 36.746MHz radiated emission with a margin of 13.96dB.

Radio Disturbance

2.1 Test Results

	Results
Conducted Emission	N/A
Radiated Emission	PASS

Note : This device is power supplied from Car Battery. So, the conducted emission is not performed.

2.2 Frequency Range

Conducted Emission : 150 kHz - 30 MHz

Radiated Emission : 30 MHz - 1000 MHz

2.3 Limits Of Conducted And Radiated Emission

2.3.1 Limit Of Conducted Emission Of FCC Part 15, Subpart B

FREQUENCY (MHz)	Class A (dBuV)		Class B (dBuV)	
	Quasi - peak	Average	Quasi - peak	Average
0.15 - 0.5	79	66	66 - 56	56 - 46
0.50 - 5.0	73	60	56	46
5.0 - 30.0	73	60	60	50

Note : (1) The lower limit shall apply at the transition frequencies.

(2) The limit decreases linearly with the logarithm of the frequency in the range 0.15 to 0.50 MHz.

(3) All emanation from a class A/B digital device or system, including any network of conductors and apparatus connected there to, shall not exceed the level of field strengths specified above.

2.3.2 Limit Of Radiated Emission Of FCC Part 15, Subpart B

FREQUENCY (MHz)	Class A (at 10m)*	Class B (at 10m)*
	dBuV/m	
30-230	40	30
230-1000	47	37

* Detector Function : Quasi - Peak

2.4. Test of Conducted Emission

2.4.1 Test Equipments

Equipment	Manufacturer	Model No.	Date of Calibration
Test Receiver	ESVS 10	Rohde & Schwarz	Apr. 2007
TWO-LINE V-NETWORK	NNB 41	SCHAFFNER	Sep. 2006
TWO-LINE V-NETWORK	ENV216	Rohde & Schwarz	Jan. 2007

2.4.2 Test Site

Name and address : SGS Testing Korea Co., Ltd.
 18-34, Sanbon-dong, Gunpo, Gyeonggi-do, Korea, 435-041

2.4.3 Operating Environment

Temperature : °C Humidity : %RH
 Atmospheric Pressure : kPa

2.4.4 Measurement Data

Measurement Bandwidth : 9kHz

Date of Test :

FREQ. (MHz)	LEVEL(dB μ V)		LINE	LIMIT(dB μ V)		MARGIN(dB)	
	Q-Peak	Average		Q-Peak	Average	Q-Peak	Average
			NA				

* Measurements using CISPR quasi-peak mode



Forest Lee / Test Engineer

2.5 Test of Radiated Emission

2.5.1 Test Instruments

Description	Manufacturer	Model No.	Date of Calibration
Amplifier	8447F	HP	Jul. 2006
Test Receiver	ESVS 30	Rohde & Schwarz	Apr. 2007
Bi-Log Antenna	HL562	Rohde & Schwarz	Sep. 2006
Spectrum Analyzer	8593E	HP	Sep. 2006

2.5.2 Test Site

Name and address : SGS Testing Korea Co., Ltd.
 18-34, Sanbon-dong, Gunpo, Gyeonggi-do, Korea, 435-041

2.5.3 Operating Environment

Temperature : 24.5 °C Humidity : 46 %RH
 Atmospheric Pressure : 100 kPa

2.5.4 Measurement Data

Measurement Bandwidth : 120 kHz

Date of Test : June, 25, 2007

FREQ. (MHz)	LEVEL (dB μ V)	POL (H/V)	AF (dB)	CL (dB)	F/S (dB μ V/m)	LIMIT (dB μ V/m)	MARGIN (dB μ V)
36.75	9.5	H	15.76	0.78	26.04	40.0	13.96

Note: The other emission level is very lower than the limit by over 20dB



Forest Lee / Test Engineer

3. Photographs of Test

- Front View of Conducted Emission

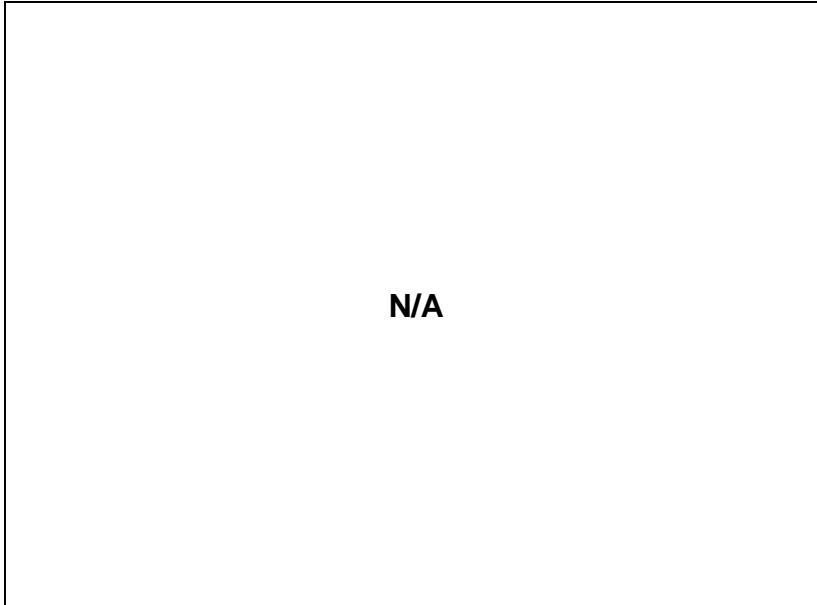

- Rear View of Conducted Emission

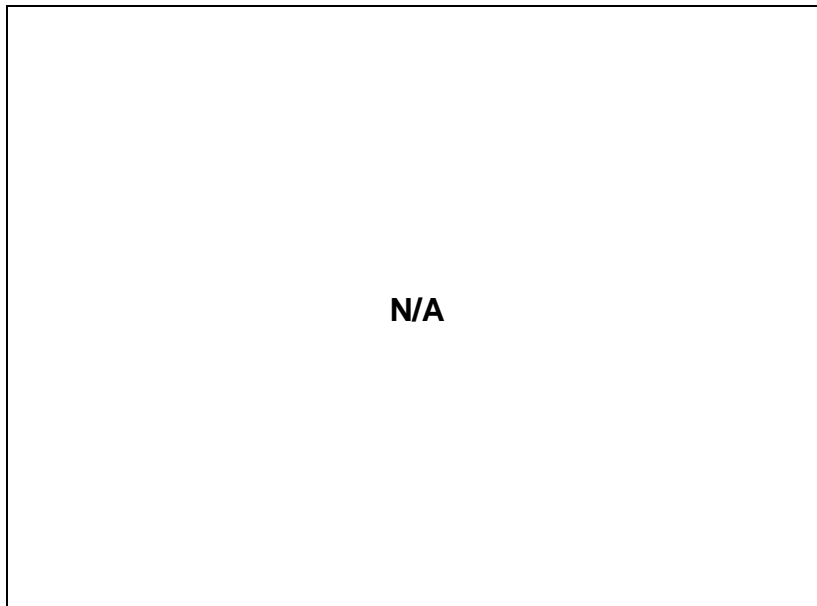

- Front View of Radiated Emission



- Rear View of Radiated Emission

