



OKA – 315R

RECEIVER, RF Keyless Entry System

FCC Operation Statement

This device complies with part 15 of the FCC Rules.

Operation is subject to the following two conditions:

- (1) This device may not cause harmful interference
- (2) This device must accept any interference received, including interference that may cause undesired operation.

FCC Compliance Statement

This equipment has been tested and found to comply with the limits for a Class B digital device, pursuant to part 15 of the FCC Rules. These limits are designed to provide reasonable protection against harmful interference in a residential installation.

This equipment generates, uses and can radiate radio frequency energy and, if not installed and used in accordance with the instructions, may cause harmful interference to radio communications. However, there is no guarantee that interference will not occur in a particular installation. If this equipment does cause harmful interference to radio or television reception, which can be determined by turning the equipment off and on, the user is encouraged to try to correct the interference by one or more of the following measures:

- Reorient or relocate the receiving antenna.
- Increase the separation between the equipment and receiver.
- Connect the equipment into an outlet on a circuit different from that to which the receiver is connected.
- Consult the dealer or an experienced radio/TV technician for help.

Caution !

Any changes or modifications to the equipment not expressly approved by the party responsible for compliance could void your authority to operate the equipment.

Table of contents

1.	Constitution of the Radio Frequency Keyless Entry system Controller for vehicle	1
2.	User's manual (provisionally)	2
3.	Block diagram	3
4.	Specification	4
5.	Features	5
6.	Derivatives	5
7.	PCB	6
7.1	Circuit diagram	6
7.2	Parts layout	7
7.3	Parts list	11
7.4	Connector	14
7.5	Photographs	15
8.	RF module	18
8.1	Block diagram	18
8.2	Circuit diagram	19
8.3	Part layout	20
8.4	Part list	21
9.	Sticker	23

1. Constitution of the Radio Frequency Keyless Entry System for vehicle

The radio frequency keyless entry is a system that it controllers locking and unlocking the door by wireless remote controller. This system consists of three components. The TRANSMITTER is a device that transmits the signal when the button is pressed. The transmission signal consists of several synchronous codes, unique identification code, security code and function code. The RECEIVER is fixed inside the vehicle. It works intermittently to prevent the battery exhaustion. When the receiver detects the synchronous code, it runs continuously to receive the signals completely. After receiving the signal, the receiver decides which operation will be performed. The user can select the following operations by pressing the button of the remote transmitter.

OPERATION	ACTION
LOCK	lock the door
UNLOCK	unlock the door
PANIC	alarm the horn

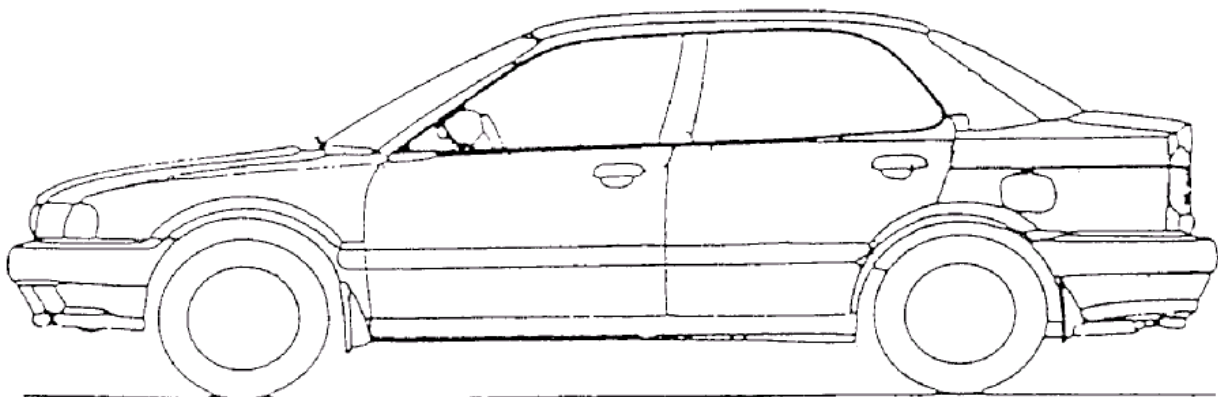

Transmitter
Freq : 313.85MHz

2. User's manual (provisionally)

TRANSMITTER

You can lock and unlock your vehicle with the remote transmitter.

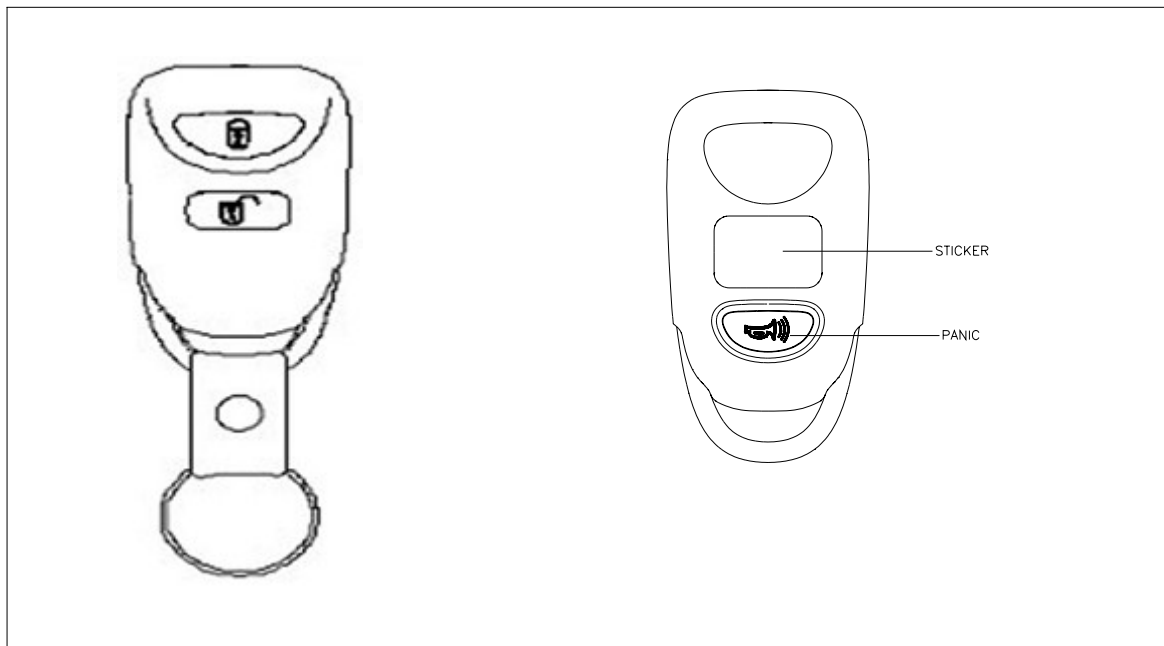

LOCK

When you push the LOCK button, all the doors will lock.

You cannot lock any of the doors with the remote transmitter if any door is open or the key is in the ignition switch.

UNLOCK

When you push the UNLOCK button, all the doors will unlock.

You cannot unlock any of the doors with the remote transmitter if any door is open or the key is in the ignition switch.

PANIC

When you push the PANIC button, Horn will alarm.

3. Block diagram

This is the block diagram concerning to the receiver.

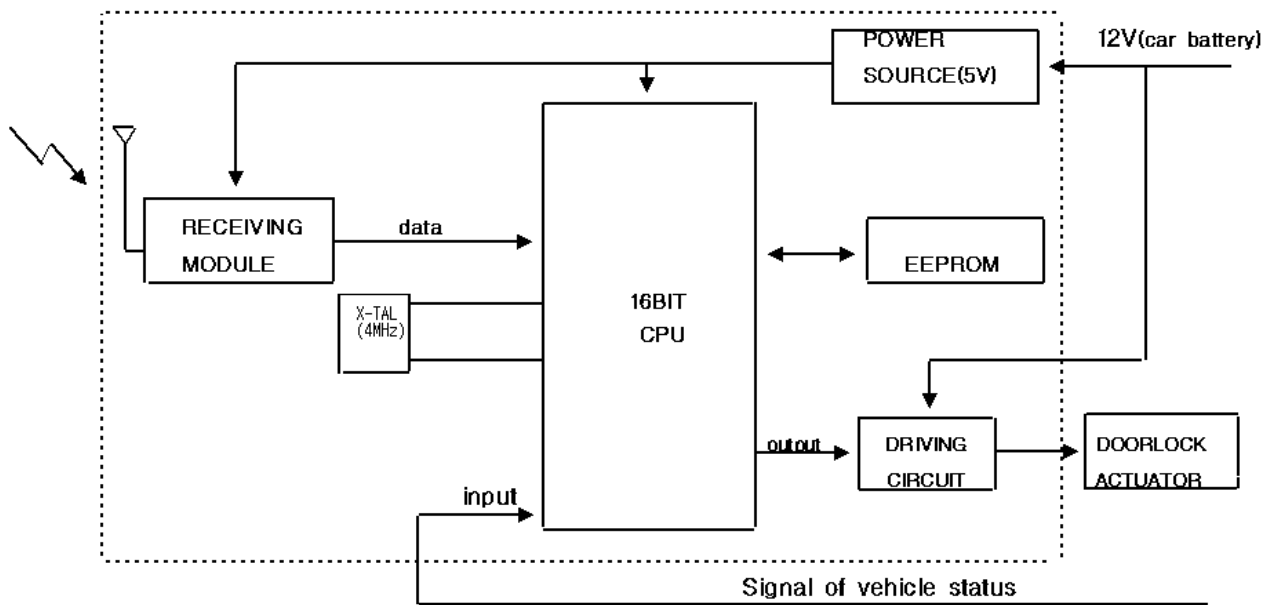

figure 3.1 block diagram of the receiver

4. Specification

4.1 CPU

Type	MB90F867(16bit)
ROM	Manufacturer : Fujitsu 128Kbytes
RAM	6Kbytes
Clock frequency	4MHz
Clock frequency generation	Crystal resonator
Package	100pin QFP

4.2 EEPROM

Type	S-93C56XXX
Memory	Manufacturer: Seiko. Elec 2Kbit
Package	8pin SOP

4.3 RF Receiver Module

Type	G8X-21RX-KO1
Local clock frequency	Manufacturer : OMRON OKA 313.85MHz
Frequency generation	Crystal resonator
Modulation Scheme	FSK
Bandwidth	±200KHz
Carrier Detect Sensitivity	11dBuVemf

4.4 Others

Dimension	146mm×114mm×36mm
Weigh	352g
Battery	CAR Battery(DC 12V)
Operation Voltage, Current	DC12V,50mA (4mA on standby)
Operation Temperature	-30℃ ~ 30℃

5. Features

5.1 Door lock control

The LOCK relay in the receiver drives the door lock actuators to "LOCK"-side when LOCK button of transmitter was pressed. The UNLOCK relay in the receiver drives the door lock actuators to "UNLOCK"-side when UNLOCK button of transmitter was pressed. These facility doesn't work if the key is inserted the key clinder or the door is open.

5.2 Battery saving

Because of the power source of the receiver is car Battery, it is very important problem to minimize a power consumption. The receiver's CPU works intermittently to prevent the battery exhaustion.

6. Derivatives

OKA-315R is an integrated controller for a car body control, includes the keyless entry receiver. The integrated. controller consists of the multiple control functions as follows, centralized door lock, turn-signal lamp, room-lamp, intermitted wiper, power window timer, ignition key illumination, warning buzzer and so on.

7. Connector

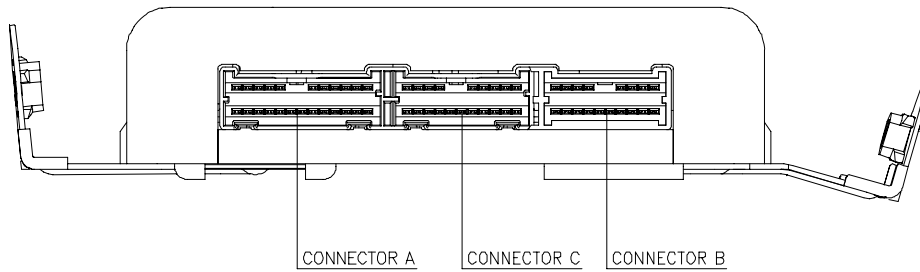

figure 7.4 the shape of the connector

NO	CONNECTOR "A"	CONNECTOR "B"	CONNECTOR "C"
1	ROOM LAMP	SHIFTR SW	HI-SCAN
2	B+	-	DRIVE DOOR LOCK SW
3	IGN1	RR WPER SW	ASSIST DOOR LOCK SW
4	ALT "L"	FRONT DEICER RELAY	DRIVE DOOR KEY LOCK SW
5	DRIVER DOOR SW	TAIL LAMP RELAY	RR INT SW
6	AS DOOR KEY LOCK SW	SEAT BELT INDICATOR	T/GATE KEY UNLOCK SW
7	MTS Tx	KEY ILLUMI LAMP	RPAS BUZZER SW
8	FRONT DEICER SW	B/HORN RELAY	DRIVE UNLOCK RELAY
9	FRONT FOG SW	-	UNLOCK RELAY
10	HEAD LAMP SW	-	SPEED SENSOR
11	WASHER SW	SAFETY RLY	REAR DOOR LOCK SW
12	SIGNAL GND	REAR DEFOGGER RELAY	AUTO DOOR UNLOCK(A/BAG)
13	IGN2	DRL	ASSIST DOOR KEY UNLOCK SW
14	DOOR WARN'G SW	POWER WINDOW RELAY	DRIVE DOOR KEY UNLOCK SW
15	MTS Rx	WIPER RELAY	HOOD SW
16	ASSIST DOOR SW	REAR FOG RELAY	RR WASHER SW
17	4 DOOR SW	CHIME BELL	T/GATE SW
18	TAIL SW	POWER GND	HAZARD RELAY
19	CODE SAVING		START INHABIT RELAY
20	SEAT BELT SW		LOCK RELAY
21	REAR DEFOGGER SW		
22	REAR FOG SW		
23	INT SW		
24	INT VOLUME		

This is the pin assignment of the connector