

Appendix 5.

Schematics

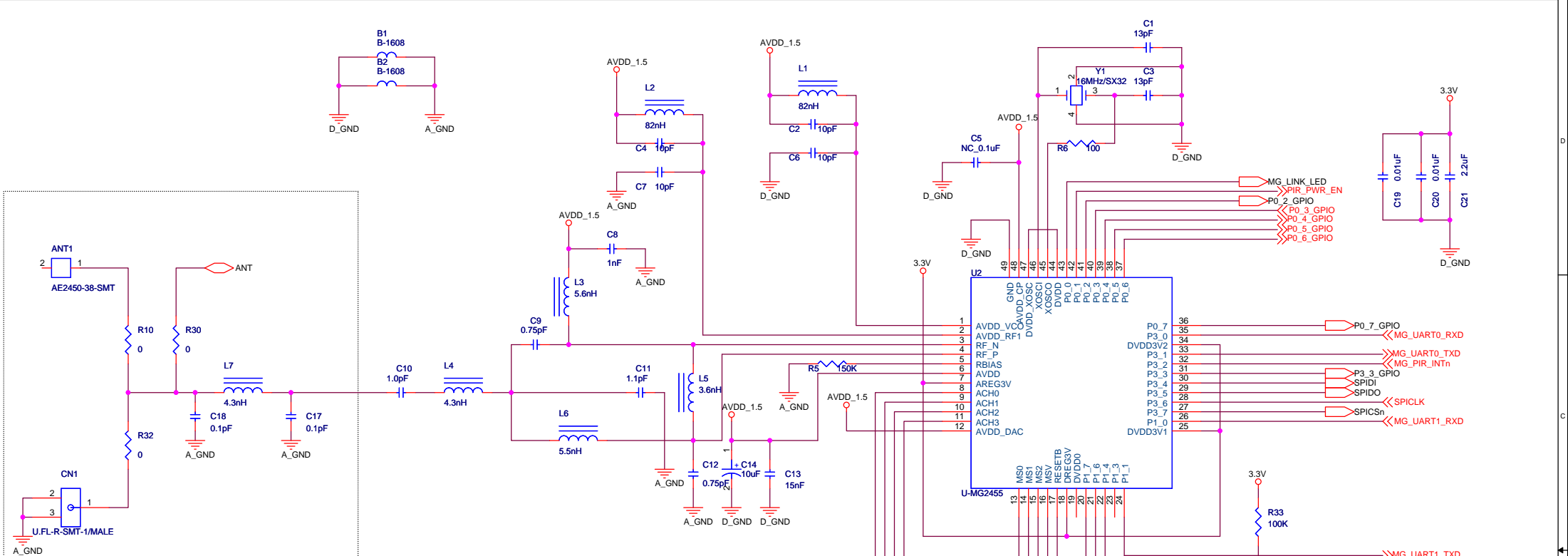

Shield CAN Outside

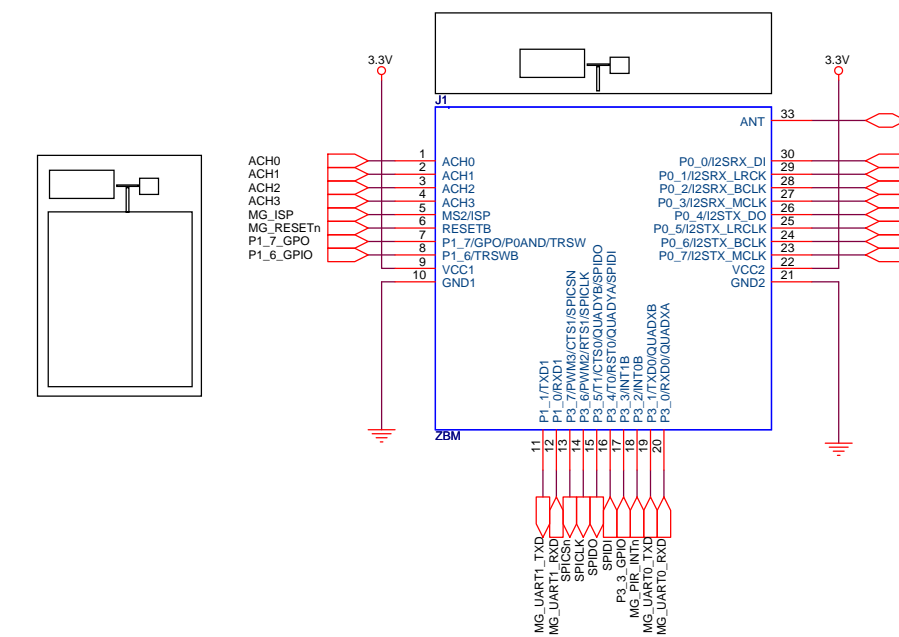

Sig. Name	Normal	Fusing
MG_ISP	Low	High
MG_RESETn	High	

Require external pull-up
PIR_PWR_EN, SPICSn, MG_PIR_INTn

NOTE1 NOTE-ONE SIDE
* Basic chip component size

Resistor	1608(0603)	Capacitor	1608(0603)
TANTAL CAP	3216	INDUCTOR	1005
Jumper	SMD TYPE : DIP TYPE :		

PROJECT NAME
GREEN HIVE ZIGBEE

Size A3	Page Name <Doc>	Rev V1.0
------------	--------------------	-------------

Date: Thursday, April 05, 2012 Sheet 1 of 1