



## OPERATING INSTRUCTIONS

### **Quinta**

Digital Wireless Conference System

1.	Safety Instructions	Page	3
1.1	Quinta CU Control Unit / Quinta Charger	Page	3
1.2	Quinta MU Microphone Unit	Page	4
1.3	Disposal	Page	4
2.	Quinta CU Control Unit	Page	5
2.1	Controls and Indicators	Page	5
2.2	Where to Place the Control Unit	Page	6
2.3	How to Connect the Antennae	Page	6
2.3.1	Direct Connection	Page	6
2.3.2	Remote Connection	Page	6
2.4	Audio Connection	Page	7
2.5	Power Supply	Page	7
2.6	Connection of Media Control System and PC	Page	7
2.7	How to Switch the Control Unit On/Off	Page	8
2.8	Rack Mounting	Page	8
3.	Quinta MU Microphone Units	Page	9
3.1	Controls and Indicators	Page	9
3.2	How to Connect the Gooseneck Microphone	Page	10
3.3	Switching On/Off	Page	11
3.4	Powering / Operating Time	Page	12
3.5	Powering with CA 2458 Mains Power Adapter	Page	12
3.6	Operating Modes	Page	12
3.6.1	Normal Operating Mode	Page	12
3.6.2	FiFo Mode	Page	12
3.6.3	Push-To-Talk Mode	Page	12
3.6.4	Voice Activation Mode	Page	13
3.7	Maintenance of the Microphone Units	Page	13
4.	Programmable Functions of the Microphone Units with the Quinta Conference Software	Page	13
4.1	Security Code	Page	13
4.2	Programmable Function Button of the Chairman Microphone Unit	Page	14
4.3	Request-To-Talk Mode	Page	15
5.	Quinta CD 2 Charger in the Quinta CC 2   CC 2 / 600 Case	Page	16
5.1	How to Use the Charger	Page	16
5.2	Charging Process	Page	16
6.	Battery Charging with External Mains Power Adapter	Page	17
7.	Trouble Shooting	Page	17
7.1	Simultaneous Operation of the Quinta Conference System and other 2.4 GHz Devices	Page	19
7.1.1	Physikalische Grundlagen	Page	19
7.1.2	Quinta and WLAN or WiFi	Page	19
7.1.3	Quinta and Bluetooth	Page	20
7.1.4	Example for Quinta, Media Control System and WLAN	Page	20
8.	Components	Page	21
9.	Accessories	Page	21
10.	Technical Specifications	Page	22
	EC-Declaration of Conformity	Page	24
	FCC Regulation	Page	26

Thank you for selecting the digital wireless Quinta conference system. Please take some time to read carefully through this manual before setting up the equipment.

## 1. Safety Instructions

### 1.1 Quinta CU Control Unit / Quinta Charger

1. Read these instructions.
2. Keep these instructions.
3. Heed all warnings.
4. Follow all instructions.
5. Do not use this apparatus near water.
6. Clean only with dry cloth.
7. Do not install near any heat sources such as radiators, heat registers, stoves, or other apparatus (including amplifiers) that produce heat.
8. Protect the power cord from being walked on or pinched particularly at plugs, convenience receptacles, and the point where they exit from the apparatus.
9. Only use attachments/accessories specified by the manufacturer.
10. Unplug this apparatus during lightning storms or when unused for long periods of time.
11. Refer all servicing to qualified service personnel. Servicing is required when the apparatus has been damaged in any way, such as power supply cord or plug is damaged, liquid has been spilled or objects have fallen into the apparatus, the apparatus has been exposed to rain or moisture, does not operate normally, or has been dropped.

#### Exemption from liability

- beyerdynamic GmbH & Co. KG will not be liable if any damage, injury or accident occurs due to negligent, incorrect or inappropriate operation of the product.

#### Location

- The equipment must be set up so that the mains switch, mains plug and all connections on the rear of the device are easily accessible.
- If you transport the equipment to another location take care to ensure that it is adequately secured and can never be damaged by being dropped or by impacts on the equipment.

#### Fire hazard

- Never place naked flames (e.g. candles) near the equipment.

#### Humidity / heat sources

- Never expose the equipment to rain or a high level of humidity. For this reason do not install it in the immediate vicinity of swimming pools, showers, damp basement rooms or other areas with unusually high atmospheric humidity.
- Never place objects containing liquid (e.g. vases or drinking glasses) on the equipment. Liquids in the equipment could cause a short circuit.
- Do not install near any heat sources such as radiators, heat registers, stoves or other apparatus (including amplifiers) that produce heat.

#### Connection

- The equipment must be connected to a mains socket that has an earth contact.
- Protect the power cord from being walked on or pinched particularly at plugs, convenience receptacles, and the point where they exit from the apparatus.
- Lay all connection cables so that they do not present a trip hazard.
- Whenever working on the inputs and outputs of the equipment switch off power.
- Check whether the connection figures comply with the existing mains supply. Serious damage could occur due to connecting the system to the wrong power supply. An incorrect mains voltage could damage the equipment or cause an electric shock.
- Please note that different operating voltages require the use of different types of power cable and plugs.

Please refer to the following table:

Voltage	Power plug according to standard
110 - 125 V	UL817 and CSA C 22.2 no 42.
220 - 230 V	CEE 7 page VII, SR section 107-2-D1/IEC 83 page C4.
240 V	BS 1363 (1984): "Specification for 13A fused plugs and switched and un-switched socket outlets."

- If the equipment causes a blown fuse or a short circuit, disconnect it from the mains and have it checked and repaired.
- Do not hold the mains cable with wet hands. There must be no water or dust on the contact pins. In both cases you could receive an electric shock.
- The mains cable must be firmly connected. If it is loose there is a fire hazard.
- Always pull out the mains cable from the mains and/or from the equipment by the plug – never by the cable. The cable could be damaged and cause an electric shock or fire.
- Do not use the equipment if the mains plug is damaged.
- If you connect defective or unsuitable accessories, the equipment could be damaged. Only use connection cables available from or recommended by beyerdynamic. If you use cables you have made up yourself, all claim to warranty is null and void.

**Switching off**

- In order to switch off the device disconnect the power plug from the power socket.

**Disconnect**

- For pluggable equipment, the socket-outlet shall be installed near the equipment and shall be easily accessible.

**Maintenance**

- Only clean the equipment with a slightly damp or dry cloth. Never use solvents as these damage the surface.

**Troube shooting and servicing**

- Do not open the equipment without authorisation. You could receive an electric shock. There are no user-serviceable parts inside.
- Leave all service work to authorised expert personnel.

**Charger**

- Use only the CD2 charger or Quinta SC power supply unit to charge the rechargeable batteries integrated in the microphone units.
- Never remove the base foam section from the CD2 charger. There are no parts that can be serviced in the interior of the charger.
- The charger has been designed for charging the rechargeable batteries in the Quinta microphone stations. Only charge Quinta microphone units and no other battery operated equipment. The batteries could explode and injure you or damage the equipment.
- If you use the charger with accessories which have not been developed for it, this could result in a fire, an electric shock or physical injury.
- Never try to repair the charger yourself. There is a risk of an electric shock or causing a fire.
- Never use the charger as a mains power supply unit for electrical equipment.

## 1.2 Quinta MU Microphone Unit

**Set up**

- Always position the microphone units on a secure surface. If the microphone unit falls down, you can hurt yourself or others or damage the microphone down.
- **To align the gooseneck microphone on the microphone station and to avoid twisting it too far and causing premature wear, please note that the gooseneck must be bent no further than an angle of 90° maximum.**

**Risk of injury**

- If the microphone stations have a gooseneck microphone take care that you do not injure yourself on this e.g. poke it into your eye.
- The charging contacts of the microphone units can cause damage to property, injuries or fire damage if they come into contact with conductive material such as jewellery, keys or chains. This closes the circuit and can thus cause the material to heat up. To avoid this sort of unwanted circuit, the charging contacts must be handled with caution. This applies particularly if the microphone units are transported in a bag or some other container together with metal objects.

**Charging / rechargeable batteries**

- When charging the microphone unit in the charger, take care to ensure that you do not injure yourself when putting the station in or taking it out.
- Only switch on the charger when you have inserted all microphone units. Empty charging compartments should never be touched during the charging process. You could receive an electric shock.
- Avoid letting the rechargeable batteries in the microphone unit become too deeply discharged. The rechargeable batteries could be damaged and the life of them could be reduced.
- If battery operated equipment is not used for a lengthy period (e.g. 1 year) the self-discharge of the battery could be accelerated. The temperature for long-term storage should be between +10° C and +30° C.
- If the microphone units are not used for several months, the rechargeable batteries in the microphone units should be charged up at least twice a year in order to avoid them running out and deterioration in the performance due to self discharge.

**Volume**

- **If the participants of a meeting use a headphone with the Quinta microphone stations, please make sure that the volume is not set too high via the Quinta Conference software or the microphone unit itself. Otherwise, the hearing of the participants could permanently be damaged.**

## 1.3 Disposal

- Old batteries may contain substances that are harmful to your health and environment.
- The device provides built-in rechargeable batteries, which you cannot remove yourself, therefore, return the device to your dealer for recycling when the batteries are exhausted.
- All batteries are recycled to reclaim valuable material such as iron, zinc or nickel.
- This symbol on the product, in the instructions or on the packaging means that your electrical and electronic equipment should be disposed at the end of its life separately from your household waste. There are separate collection systems for recycling in the EU. For more information, please contact the local authority or your retailer where you purchased the product.



## 2. Quinta CU Control Unit

The Quinta CU control unit is the heart of the system. It controls the delegate and chairman microphone units. With one control unit a maximum of 4 speakers (e.g. 3 delegates and 1 chairman) can speak simultaneously. The radio transmission is in the triple band (2.4 / 5.2 / 5.8 GHz frequency band).

The control unit has been designed for installations on tables or 19" rack mounting. When setting up the system, please follow the safety instructions mentioned in chapter 1.

Furthermore, please note

- the ambient temperature of the installation site must not exceed 40 °C [104 °F].
- there must not be exceeding dust and humidity a the installation site.
- that the unit is not exposed to direct sunlight.
- the connection must be protected against direct access during operation.
- that there must be a strain relief of the cables.
- the installation site must be protected against vibrations.

### 2.1 Controls and Indicators

#### Front

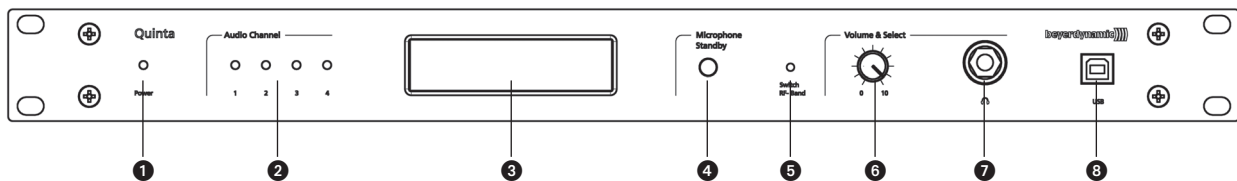

#### Rear

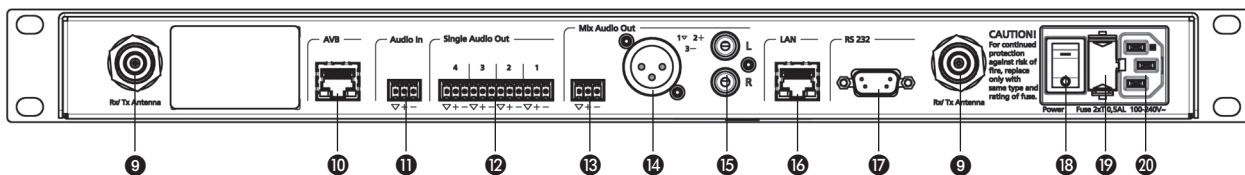

- 1 Power on LED
- 2 Audio channel LEDs 1 to 4 (white = channel vacant; red = channel occupied)
- 3 Display to indicate operating mode, channel, headphone volume
- 4 Standby button to turn off all microphone units centrally
- 5 Push-button for frequency band selection
- 6 Volume control for headphone / channel
- 7 Headphone connection
- 8 USB connection
- 9 Antenna connections
- 10 AVB (Audio Video Bridging) network connection for digital audio signals via CAT5 cables, RJ45
- 11 Audio input (Audio IN) for the connection of external sound sources, 3-pin Phoenix terminal strip, balanced
- 12 Audio output, individual channels, 4 x 3-pin Phoenix terminal strips, balanced
- 13 Audio output Mix (Master), 3-pin Phoenix terminal strips, balanced
- 14 Audio output Mix (Master), 3-pin XLR, balanced
- 15 Audio output Mix (Master), RCA, unbalanced
- 16 LAN connection for PC / network, RJ 45
- 17 Connection for media control system / PC / network, RS 232
- 18 On/Off switch
- 19 Fuse
- 20 Mains connection

## 2.2 Where to Place the Control Unit

- If you **do not** use remote antennae, place the **Quinta CU control unit** in the room where the meeting takes place. If you use **remote antennae**, place the **antennae** in the conference room.
- Avoid shadowing effect of the antennae, especially by metallic surfaces.
- A free line of sight between the Quinta MU microphone units and the antennae of the Quinta CU control unit is essential for the operation of the microphone units. Big obstacles in between can possibly affect the radio transmission. In such specific installations the use of remote antennae can possibly achieve an improvement of the RF situation.
- If you want to install several Quint CU control units in a 19" rack, please make sure that there is a minimum distance of 1 U between the control units to avoid interferences, especially if you do not use remote antennae.

## 2.3 How to Connect the Antennae

### 2.3.1 Direct Connection

- Connect the antennae to the antenna connections ⑨. Please note that for diversity operation both antennae have to be connected! A weighting circuit is used to make sure that the better antenna signal is received.
- For stand-alone operation we recommend using the supplied CA Q 11 angled rod antennae.

### 2.3.2 Remote Connection

- The Quinta CU control unit can also be operated with remote antennae. We recommend extremely low attenuation connecting cables which are 10 m [32.8 ft] or 20 m [65.6 ft] long. Please note that the antennae have to be installed remotely.

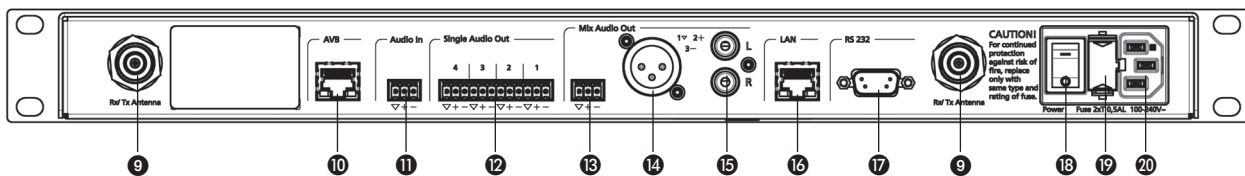

#### Important:

- There must be an **unobstructed path** between the **microphone units** and the **antennae**, i.e. **between the Quinta CU control unit** or the **remote antennae** and the **microphone units there must not be any obstacles**. With a free line of sight between the control unit and the microphone units and the rod antennae the **range is between 30 to 50 m [98.4 ft to 164 ft]**. For optimum range the surface of the table is important, wood or plastic tables are ideal, but metal tables can cause interferences and reduce the range.
- Please make sure that with a free line of sight the **minimum distance** between the **antennae** and the **microphone units** is **not less than 1 m [3.2 ft]**.

### 2.4 Audio Connection

- If required, connect the Audio Mix 13, XLR 14 or Cinch 15 master output of the Quinta CU control unit to the input of a mixing console or amplifier.
- If you want to feed the audio signals into a network, connect the AVB connection \* 10 to the network by using a CAT5 cable. You can also connect other audio sources or devices with AVB connection, which are defined as "Talker" (e.g. microphone) or "Listener" (e.g. loudspeaker), as well as DSP devices for audio data processing.
- You can connect e.g. external loudspeakers to the individual channels of the audio output 12.
- Always route cables running to the unit where they will not be pinched or cut by heavy or sharp objects.

\*AVB is a uniform standard for Audio/Video networks for data communication with which the most different components can communicate with each other. AVB is based on IEEE 802 Ethernet for the real-time streaming of audio and video contents via Ethernet. AVB features a bandwidth reservation, a low jitter master clock, low latencies and a timing mechanism for the synchronisation. AVB supplies a sufficient raw data bandwidth to transmit up to 200 audio channels via one single Gigabit Ethernet port. Field tests showed that a part of this can be used for extended functions. In order to achieve this, an AVB network separates the AVB data traffic from the Standard Ethernet data traffic and manages streams accordingly. This means that an AVB network can be connected to a Standard Ethernet network to transfer data to and from the network. The performance of the streaming of media can only be guaranteed within a group of AVB capable devices.

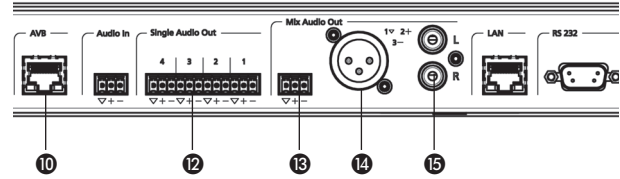

### 2.5 Power Supply

- Verify that the voltage rating of the unit matches that of the AC mains outlet you are to use. If you connect the unit to the wrong voltage, you may seriously damage it.
- Always route cables running to the unit where they will not be pinched or cut by heavy or sharp objects.
- Connect the Quinta CU control unit to the mains 20. The internal power supply unit of the control unit can automatically adjust between 100 and 240 V at 50 - 60 Hz.

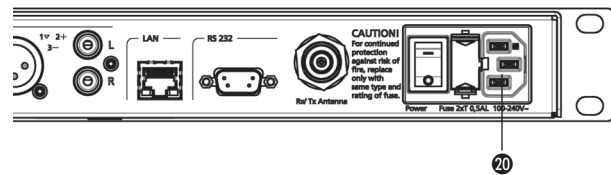

### 2.6 Connection of Media Control System and PC

- If you want to configure, control and monitor the system via the Quinta Conference software, connect the USB connection 8 or the LAN connection 16 or RS 232 17 (null modem cable required) with a media control system or PC. The default IP address of the Quinta CU control unit is: 192.168.1.55
- If the Quinta CU control unit is connected e.g. via a network with a WLAN Access Point, you can access the web server of the Quinta CU control unit e.g. with a smartphone.



**Important:**

Never access the Quinta CU control unit via the media control system and the Quinta Conference software simultaneously. In this case a correct function of the system cannot be guaranteed.

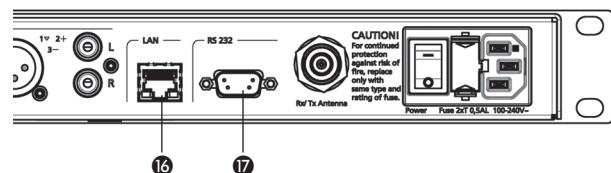
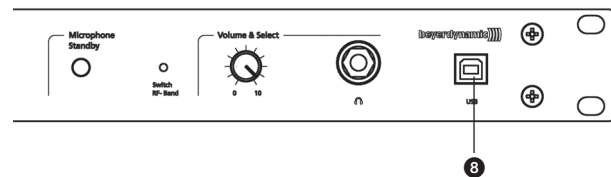

## 2.7 How to Switch the Control Unit On/Off

- Turn on the Quinta CU control unit with the On/Off switch 18.
- The Power on LED 1 will illuminate.
- The channel LED 1 to 4 will illuminate white to indicate the availability. As soon as a microphone is activated, the channel LED 2 will illuminate red to indicate that the channel is occupied.

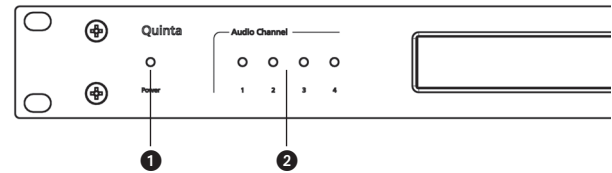
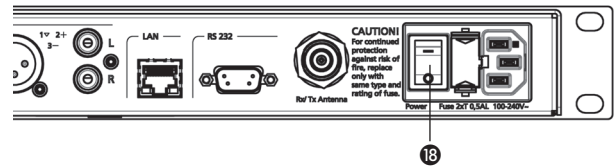

- At the factory the RF bands 2.4; 5.2 or 5.8 GHz\* will be activated (Automatic Mode). This means that the Quinta CU control unit will select a free frequency and if necessary it will select a different free frequency without any interferences. This operating mode is recommended for normal use. The free frequencies for the Quinta CU control unit can be deactivated via the Quinta Conference software. The microphone unit will automatically be adjusted to the frequency of the Quinta CU control unit.
- If required you can select a fixed frequency (Manual Mode). Use the tip of a pencil or a paper clip to press the countersunk push-button for RF band selection 5. The push-button 5 switches through all available frequencies one after another and back to the "Automatic Mode". The manual frequency selection can take up to 1.5 seconds and is immediately displayed. The microphone units are automatically adjusted to the selected frequency band.

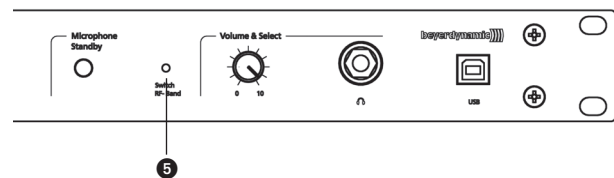

**\*Note:**

The availability of the RF bands 2.4; 5.2 or 5.8 GHz depends on the selected region.

## 2.8 Rack Mounting

- When mounting the Quinta CU control unit into a 19" rack housing leave 1 U for a ventilation panel above and below the control unit.
- Make sure that the mains connection, mains switch and all audio connections on the rear of the device are easily accessible.



### 3. Quinta MU Microphone Units

For the Quinta conference system there are three different microphone units available:

- Quinta MU 23 chairman microphone unit with three buttons (microphone, clear, function)
- Quinta MU 22 double delegate microphone unit with two microphone buttons
- Quinta MU 21 delegate microphone unit with one microphone button

The microphone units are provided with a locking XLR connection for removable gooseneck microphones of the Classis GM 31x Q series, 3-colour backlit buttons, braille above the buttons and an integrated wideband loudspeaker with equalization.

- Each microphone unit is programmed at the factory with an individual worldwide unique device ID so that the Quinta CU control unit can control the microphone units.
- Each microphone unit is addressed with this individual device ID in the transmission protocol via radio transmission.



#### Important:

- The charging contacts of the microphone units can cause damages, injuries or fire damages if they come into contact with conductive materials such as jewellery, keys or chains. This can lead to a closed circuit and heat up the material.
- If the microphone units are to be operated by an external power supply, you can use the CA 2458 mains charger adapter.
- **To align the gooseneck microphone of the Quinta MU microphone units and to avoid twisting it too far and causing premature wear, the gooseneck must not be bent further than an angle of 90° at maximum.**

#### 3.1 Controls and Indicators

- ① Power on and operating control LED
- ② DC socket for charging the rechargeable batteries of the microphone unit or for DC operation
- ③ Charging contacts for charging in the CD 2 charger
- ④ Headphone connection
- ⑤ Volume control for headphone connection

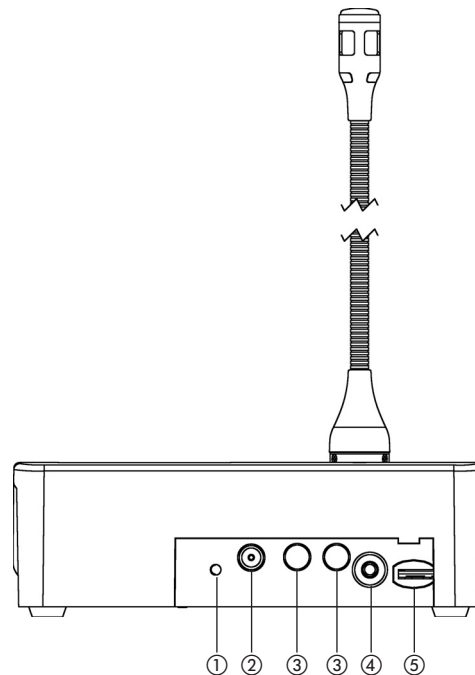

Quinta MU23 Chairman Microphone Unit

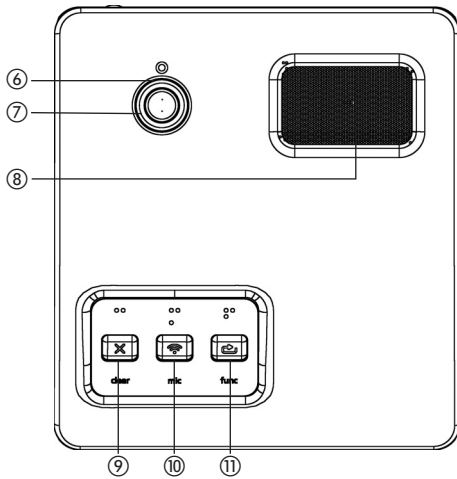

Quinta MU22 Double Delegate Microphone Unit

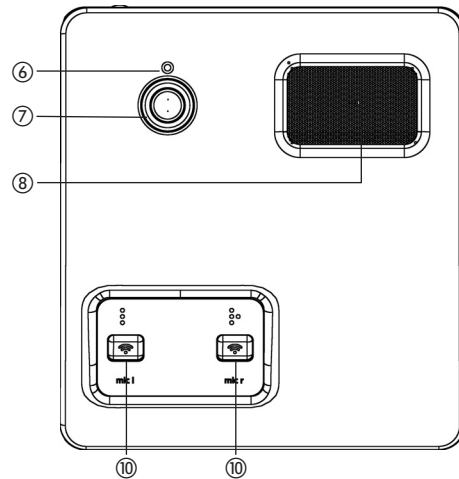

- ⑥ Opening for unlocking the gooseneck microphone
- ⑦ Connection for gooseneck microphone
- ⑧ Loudspeaker
- ⑨ "Clear" button to clear all delegate microphone units
- ⑩ Microphone button
- ⑪ Programmable function button
- ⑫ Reset button to restart the integrated microcontroller (refer also the item "Microphone unit cannot be switched off" in chapter 7. "Trouble Shooting")

Quinta MU21 Delegate Microphone Unit

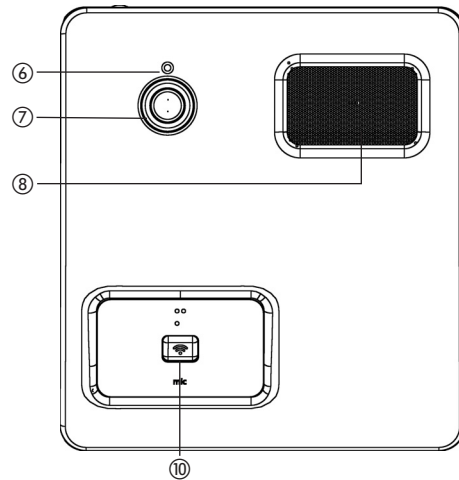

### 3.2 How to Connect the Gooseneck Microphone

The following gooseneck microphones with an LED are available to connect to the microphone unit.

- Classis GM 313 Q; 300 mm [11.81"] in length
- Classis GM 314 Q; 400 mm [15.75"] in length
- Classis GM 315 Q; 500 mm [19.69"] in length
- Classis GM 316 Q; 600 mm [23.62"] in length

- Take the gooseneck microphone by the shaft, put it into the connection for gooseneck microphones ⑦ and press the shaft downwards until it locks in place.
- If you want to remove the gooseneck microphone, press into the opening for unlocking the gooseneck microphone ⑥ with the supplied tool or a similar thin tool. Remove the gooseneck microphone by taking it by the shaft and pulling.

Bottom of Microphone Unit

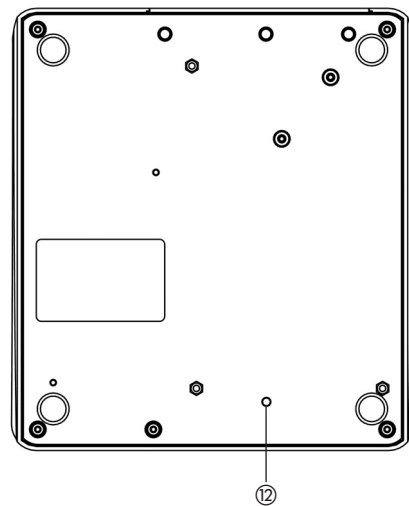

### 3.3 Switching On / Off

#### How to switch on and allocate the microphone units

- The microphone unit is switched on by pressing the microphone button ⑩. The microphone button ⑩ will light up for a moment and the operating control LED ① on the rear will illuminate green. When the connection to the Quinta CU control unit has been established, the buttons of the microphone unit will illuminate white.
- To activate the microphone or to allocate the microphone unit to a free channel of the Quinta CU control unit, press the microphone button ⑩ once again. Depending on the operating mode, the microphone button will illuminate green (normal operating mode) or red (request-to-speak mode).

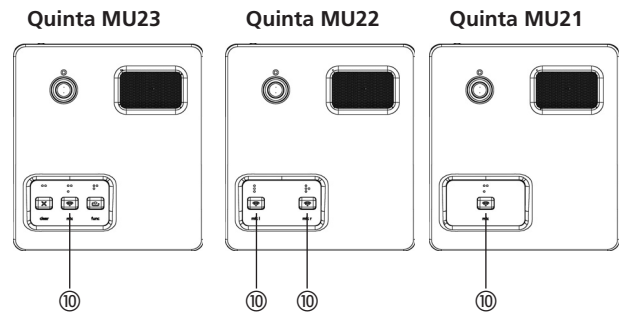

#### Switching off

- By pressing the microphone button ⑩ for more than 2 seconds the microphone unit is switched off.
- If you press the standby button ④ of the Quinta CU control unit for more than 3 seconds, you switch off all the active Quinta MU microphone units within the range of the Quinta CU control unit.
- Furthermore, the microphone units are switched off automatically, when they do not receive a signal from the Quinta CU control unit for more than 3 minutes.

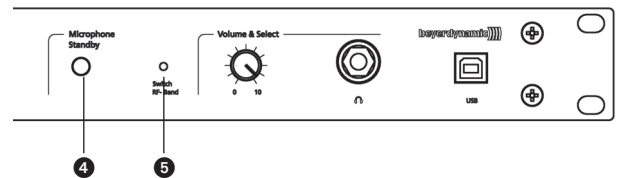

#### ⚠ Important:

- With the Quinta Conference software you can deactivate the manual switching off of the microphone unit.
- If the microphone unit is out of range of the control unit or does not have the correct PIN code, the microphone button ⑩ will flash red. After approx. 3 minutes the microphone unit will switch off automatically.
- Should the system fail to operate, i.e. the microphone unit is switched on, but no sound is heard, check the audio settings with the Quinta Conference software. If RF problems occur the microphone button ⑩ will flash red. Should the system still fail to operate, please contact your beyerdynamic representative.

#### Function Test

You can test if the microphone units are operating:

- Connect a headphone to the Quinta CU control unit ⑦.
- Turn the control ⑥ to set the volume and press the control ⑥ several times until you have listened to all channels (i.e. 4 channels).

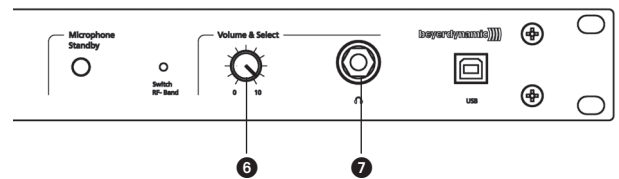

### 3.4 Powering / Operating Time

- The microphone units have an integrated rechargeable battery allowing a minimum operating time of 20 hours when fully charged.
- When the battery charge is too low for a satisfactory operation, the operating control LED ① on the rear of the microphone unit will flash. The remaining time of operation will be around 60 minutes.
- The charging state of the microphone units can be displayed with the Quinta Conference software on a PC connected to the Quinta CU control unit or via the integrated web server. Furthermore, it can be displayed on an external media control system connected to the Quinta CU control unit.

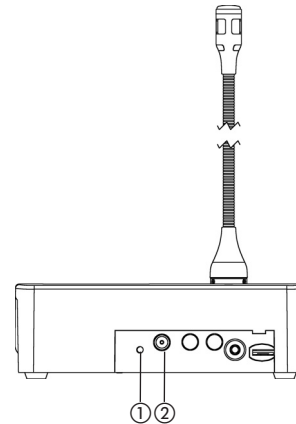

### 3.5 Powering with CA 2458 Mains Power Adapter

- The Quinta MU microphone units can also be powered via the external CA 2458 mains charger adapter, which is connected to the DC socket ② on the rear of the microphone unit.
- While the CA 2458 mains charger adapter is connected, the rechargeable battery of the microphone unit is charged. Refer also to chapter 6. "Battery Charging with External Mains Power Adapter".

### 3.6 Operating Modes

The different operating modes such as "Normal", "Push-To-Talk" or "Voice Activation" are adjusted with the Quinta Conference software for all microphone units. The standard operating mode is "Normal". Please refer also to the appropriate "Quinta Conference Software" or "Quinta Web Server" manual.

#### 3.6.1 Normal Operating Mode

- Press the microphone button ⑩ to switch on the microphone.
- The red LED of the gooseneck microphone will illuminate and the microphone button ⑩ will illuminate green: The microphone is ready to speak into it.
- Using the Quinta CU control unit, up to 4 participants (e.g. 3 delegates and 1 chairman) can speak simultaneously depending on the setting.



**Important:**

**If the number of open microphones is exceeded, a microphone can only be switched on manually when another microphone unit has been switched off.**

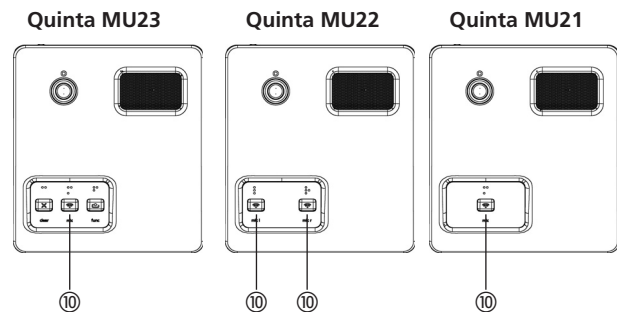

#### 3.6.2 FiFo Mode

- If the microphone units operate in the FiFo mode (first in - first out), the microphone unit that was switched on first, will be switched off, when another microphone unit is switched on and the number of open microphones (NOM) will be exceeded.

#### 3.6.3 Push-To-Talk Mode

- If the microphone units operate in the Push-To-Talk mode (PTT), the microphone button must be pressed as long as someone speaks into the microphone. This configuration is recommended for short interruptions during the meeting.

### 3.6.4 Voice Activation Mode

- If the microphone units operate in the Voice Activation mode, the microphone units are switched on via voice control. That is the microphone unit is switched on as soon as someone speaks into the microphone. In this case it is not necessary to press the microphone button.

**Important:**

The threshold and the hold time can be configured with the “Quinta Conference” software for all microphone units.

### 3.7 Maintenance of the Microphone Units

- For cleaning the Quinta MU microphone units when they are slightly dirty (finger prints, dust, jam or juice) use a soft, damp cloth, sponge or brush and mild liquid cleaning agent (e.g. washing-up liquid). Do not use any solvent containing cleaners.
- Make sure not to allow any water to enter the microphone capsule or housing.
- Clean the charging contacts with spirit or isopropyl alcohol from time to time. While cleaning avoid contact with the painted surface.
- Clean the pop shield with clear, warm water. Make sure that it is completely dry before you put it on the microphone again.

## 4. Programmable Functions of the Microphone Units with the Quinta Conference Software

The functions of the microphone units described in the following are only available, when they have been programmed with the Quinta Conference software before. Please refer to the “Quinta Conference Software” manual.

### 4.1 Security Code

By using the Quinta Conference software you can enter an alphanumerical code for the Quinta MU microphone units and the Quinta CU control unit within one system. This will increase the safety against unauthorised listening. Microphone units, which do not have this code are not recognised by the control unit and will be deactivated.

## 4.2 Programmable Function Button of the Chairman Microphone Unit

Depending on the configuration the following functions are possible with the function button ⑩: mute, clear or priority. The function button can be configured via the control unit with the Quinta Conference software.

### 1. Normal

All active delegate microphone units will be cleared and the microphone of the chairman unit will be switched on. The delegates can switch on their microphones again, when the chairman switches off his microphone.

### 2. Mute

All active delegate microphone units will be muted when the chairman is speaking and will be reactivated when the chairman switches off his microphone.

### 3. Clear

All active delegate microphone units are cleared and can be switched on afterwards.

### 4. How to Mute Audio IN ports

First push mutes the port, the next one enables it, third one mutes again etc.

If the chairman presses the function button, the audio input of the Quinta CU control unit will be muted. The microphone button ⑩ will start flashing red (slowly). When the chairman turns on his/her microphone, the microphone button ⑩ will flash green (slowly). If the chairman turns off the function, the microphone button ⑩ will illuminate green.

### 5. How to Mute Audio IN ports and clear all active delegate units

By pressing the function button a second time, mute is released. By pressing the function button a third time, the audio input is muted again and all active delegate units will be cleared etc. The microphone button ⑩ will flash red (slowly). When the chairman turns on his/her microphone, the microphone button ⑩ will flash green (slowly). If the chairman turns off priority, the microphone button ⑩ will illuminate green should the microphone be still on.

### 6. How to Mute Audio OUT ports

First push mutes the port, the next one enables it, third one mutes again etc.

If the chairman presses the function button of his/her microphone unit, the audio output of the Quinta CU control unit will be muted. The microphone button ⑩ will flash red (slowly). If the chairman turns on his/her microphone, the microphone button ⑩ will flash green (slowly). If the chairman turns off priority, the microphone button ⑩ will illuminate green, should the microphone be still on.

### 7. "RS 232 Message" Function

A command is sent via the RS 232 serial interface from the Quinta CU control unit and a programmed function is carried out via a media control system for instance (e.g. light control). At the same time a command is also sent for other functions via the RS 232 serial interface from the Quinta CU control unit.

### 8. Command A/B

Two different commands according to the duration of the push of the function button.

< 1 second = command "Short press string" is transmitted

> 1 second = command "Long press string" is transmitted

These commands can be set individually with the Quinta Conference software.

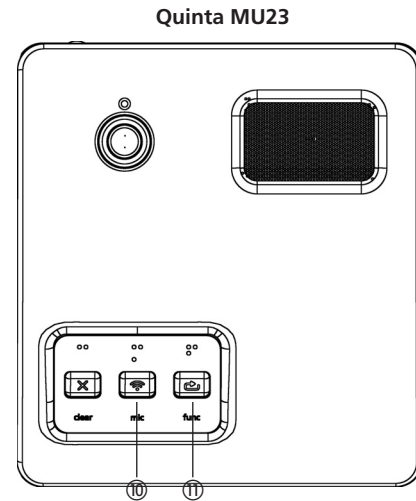

### 4.3 Request-to-Talk Mode

- This operating mode is only possible in conjunction with a PC using the Quinta Conference software or a media control system (AMX®, Crestron®, Cue etc.).
- The request-to-talk is registered in the system by pressing the microphone button ⑩ of the microphone unit.
- The allocation is made by the operator at the PC or touch screen of the media control system.
- The microphone button ⑩ is illuminated red to indicate the request-to-talk.
- If you press the microphone button ⑩ again, the request-to-talk is cleared. The backlit microphone button ⑩ will illuminate white.

Quinta MU22 Double Delegate Microphone Unit

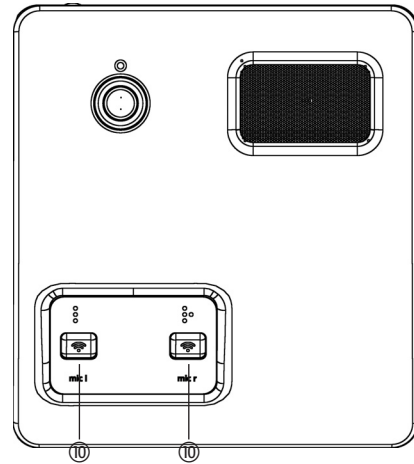

Quinta MU21 Delegate Microphone Unit

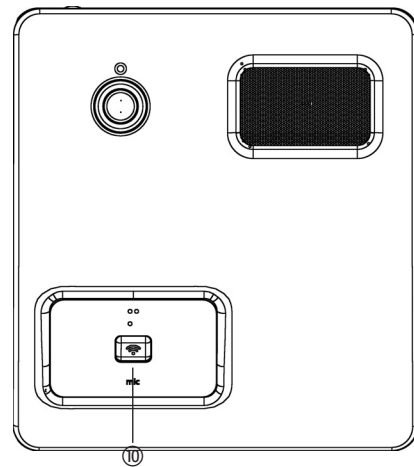

## 5. Quinta CD 2 Charger in the Quinta CC 2 | CC 2 / 600 Case

Quinta CC 2 is a modular charging and transport case. The basic version the Quinta CC 2 consists of a top cover (Quinta CT 2), a charger (Quinta CD 2) for 10 microphone unit and a bottom with casters (Quinta CW 2). This version is suitable for microphone units using the Classis GM 313 Q, GM 314 Q and GM 315 Q microphones.

For microphone units using the Classis GM 316 Q microphone the version Quinta CC 2 / 600 with a higher top cover (Quinta CT 2 / 600) will be available.

- With the Quinta CD 2 charger integrated in the Quinta CC 2 or CC 2 / 600 case you can charge a maximum of 10 Quinta MU 23/22/21 microphone units with the Classis GM 313 Q, 314 Q, 315 Q or Classis GM 316 Q microphone. The charging state can be seen from the outside through a glass panel.
- The Quinta CC 2 charging and transport case can be extended with another Quinta CD 2 charger for 10 microphone units. Because of a possible instability more than two Quinta CD 2 chargers must not be piled up. Quinta CD 2 chargers that contain microphone units with the Classis GM 316 Q microphone cannot be piled up because of the microphone length.
- For the Quinta CC 2 or CC 2 / 600 charging and transport case there is an optional compartment available for storing the Quinta CU control unit and accessories such as cables and gooseneck microphones.

### 5.1 How to Use the Charger

- To achieve a 100% battery capacity of the rechargeable batteries, all microphone units should have 2 complete charging cycles (charging and discharging) at least. Only after several charging and discharging cycles, the rechargeable batteries will achieve their full capacity.
- The Quinta MU microphone units are provided with high-performance nickel-metal hydrid (NiMH) batteries. These guarantee minimum operating times of 20 hours. It takes about 2.5 hours to charge them.
- The service life of the batteries largely depends on the manner in which they are looked after and on how well the user recharges them. To extend the service life of the batteries for as long as possible, the following charging cycle is recommended:
  - Do not keep the microphone units in the charging case when it is switched on.
  - Only put the microphone units in the charging case before a conference / application and fully charge them until the “fully charged” status is shown.
  - In particular, when the microphone units are inserted, the charging case should not be constantly switched on and off. For each charging cycle, there is an initial 5-minute charge to check the battery status. If the case with the microphone units is switched on every day (for example, because the mains is switched off automatically or by a cleaner), the microphone units will be slowly but constantly overcharged and this will damage the batteries.
  - The NiMH batteries used minimise the so-called “memory effect”, but their capacity is reduced when they are only partially discharged on a regular basis. For this reason, the microphone units should be fully discharged every three months until they switch off automatically. They can then be fully recharged. This procedure can, if necessary, be repeated a second time.
  - If, despite this measure, the microphone unit does not operate for a sufficiently long period of time, the battery has reached the end of its service life and must be replaced. The typical service life of the battery is greatly dependent on whether or not the above points are observed. This is why batteries are not covered by warranties. If the above points are observed, a battery typically has a service life of at least two years or 500 complete charging cycles, depending on which occurs first.

### 5.2 Charging Process

1. Connect the charger to AC power and switch it on. The switch will illuminate.
2. Put the switched-off microphone units into the charging compartments. If microphone units are switched on, they are switched off automatically. When the microphone units are used again, they must be switched on by hand.
3. The charging process is indicated by the LED of the gooseneck and can be seen from the outside through a glass panel. LED indicator when the batteries are recharged:
  - a) Gooseneck LED is flashing red . . . . . Battery is charged
  - b) Gooseneck LED illuminates red permanently. . . . . Battery is completely full
  - c) Gooseneck LED is flashing red rapidly . . . . . Error



**Note:**

- If an error has occurred, try to restart the charging process. If the LEDs are still flashing rapidly, please contact your beyerdynamic dealer.
- After some time the capacity of the rechargeable batteries is reduced technically. This will reduce the operating time.
- It is normal that the rechargeable batteries are heated up during the charging process.
- Clean the charging contacts with spirit or isopropyl alcohol from time to time. While cleaning avoid contact with the painted surface.



### 6. Battery Charging with External Mains Power Adapter

- The Quinta MU microphone units can also be charged with the external CA 2458 mains power adapter, which is connected to the DC socket ②.
- The operating control LED ① will indicate the charging process: LED indicator when the batteries are recharged:
  - a) LED is flashing red. . . . . Battery is charged
  - b) LED illuminates red permanently. . . . . Battery is completely full
  - c) LED is flashing red rapidly . . . . . Error



**Wichtig:**

- After some time the capacity of the rechargeable batteries is reduced technically. This will reduce the operating time.
- It is normal that the rechargeable batteries are heated up during the charging process.
- When the battery is completely empty, the charging time is around 2.5 hours.
- If the microphone unit is switched on during the charging process, the LED ① will illuminate green.

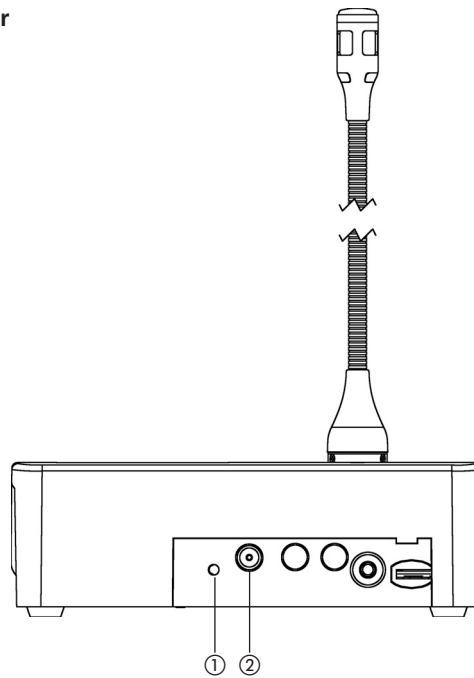

### 7. Trouble Shooting

If problems occur that you do not find listed below, reset the Quinta system to the standard configuration with the Quinta Conference software. Please refer also to the appropriate manual.

Problem	Possible Cause	Solution
Microphone button ⑩ flashes red rapidly	<ul style="list-style-type: none"> <li>• Control unit is not switched on</li> <li>• Microphone unit is not within the range of the control unit</li> <li>• Frequency bands have been configured incorrectly</li> <li>• Microphone unit does not have the correct PIN code</li> </ul>	<ul style="list-style-type: none"> <li>• Switch on the control unit</li> <li>• Reduce the distance between control unit and microphone units</li> <li>• Check the adjusted frequency bands with the Quinta Conference software</li> <li>• Deactivate the PIN function in the Quinta Conference software. Make sure that all microphone units to be configured with the PIN code are within the range of the Quinta CU control unit. Enter the requested PIN code in the Quinta Conference software and select "Send to MUs". Activate the PIN function in the Quinta Conference software again. All microphone units that have received the new PIN code will communicate with the Quinta CU control unit. Other microphone units will not communicate (microphone button is flashing red).</li> </ul>
Operating control LED ① flashes	<ul style="list-style-type: none"> <li>• Battery is almost empty</li> <li>• Low battery warning to indicate that the battery is almost empty</li> </ul>	<ul style="list-style-type: none"> <li>• Recharge the battery inside the microphone unit</li> </ul>
Microphone unit goes off	<ul style="list-style-type: none"> <li>• Check if the battery is still full</li> <li>• PIN code is activated</li> </ul>	<ul style="list-style-type: none"> <li>• If the battery is empty, recharge it</li> <li>• Deactivate PIN code</li> </ul>

Problem	Possible Cause	Solution
Allocation is not possible	<ul style="list-style-type: none"> <li>• All channels are occupied</li> <li>• Check the number of open microphones (NOM) with the Quinta Conference Software or Quinta Web Server</li> <li>• Microphone unit is not within the range of the control unit</li>   <li>• Interference caused by WLAN</li>   <li>• System operates in the PC controlled mode (Controller)</li> </ul>	<ul style="list-style-type: none"> <li>• Switch off an activated microphone</li> <li>• If possible increase the NOM with the Quinta Conference Software or the Quinta Web Server</li> <li>• Reduce the distance between control unit and microphone units</li> <li>• Use the standard settings mentioned in the Quinta Conference Software manual</li> <li>• Check the settings of the frequency bands</li> <li>• Select another frequency band with the Quinta Conference Software, the Quinta Web Server or the push-button for RF frequency band selection on the front of the Quinta CU control unit</li> <li>• Set the system into the autonomous operating mode with the Quinta Conference Software or the Quinta Web Server</li> </ul>
Microphone unit cannot be switched on	<ul style="list-style-type: none"> <li>• Control unit is not switched on</li> <li>• Check the number of open microphones (NOM)</li> <li>• Check the battery</li> <li>• Microphone unit is not within the range of the control unit</li> </ul>	<ul style="list-style-type: none"> <li>• Switch on the control unit</li> <li>• If possible increase the number of open microphones (NOM)</li> <li>• If the battery is empty, recharge it</li> <li>• Reduce the distance between control unit and microphone units</li> </ul>
Loudspeaker of the microphone unit does not work	<ul style="list-style-type: none"> <li>• Check the volume setting with the Quinta Conference Software or Web Server</li> </ul>	<ul style="list-style-type: none"> <li>• Increase the volume with the Quinta Conference Software or Quinta Web Server</li> </ul>
Microphone unit cannot be switched off	<ul style="list-style-type: none"> <li>• "Manual Power Off" function is deactivated</li> <li>• Operating mode "Push-To-Talk" or "Voice activated" is active</li>   <li>• Crash of the microcontroller inside the microphone unit</li> </ul>	<ul style="list-style-type: none"> <li>• Activate the "Manual Power Off" function with the Quinta Conference Software or Quinta Web Server</li> <li>• Deactivate the operating mode "Push-To-Talk" or "Voice activated" with the Quinta Conference Software or Quinta Web Server</li> <li>• Switch off the microphone units via the control unit by pressing the Clear/Standby button for more than 3 seconds</li> <li>• Switch off the control unit. The microphone units will go off after approx. 3 minutes.</li> <li>• Press the reset button on the bottom of the microphone unit</li> </ul>
Headphone output of the microphone unit does not work	<ul style="list-style-type: none"> <li>• Microphone unit is not switched on</li> <li>• Headphone or recorder is not connected properly</li> <li>• Check the volume setting with the Quinta Conference Software or Quinta Web Server</li> </ul>	<ul style="list-style-type: none"> <li>• Switch on the microphone unit</li> <li>• Connect the headphone or recorder properly</li> <li>• Increase the volume with the Quinta Conference Software or Quinta Web Server</li> </ul>
Feedback	<ul style="list-style-type: none"> <li>• Check the external loudspeakers</li> </ul>	<ul style="list-style-type: none"> <li>• Correct the volume and position of the loudspeakers</li> </ul>
Interferences, noise	<ul style="list-style-type: none"> <li>• Check the audio level</li> <li>• Microphone unit is not within the range of the control unit</li> <li>• Check the line of sight between microphone unit and antenna</li> </ul>	<ul style="list-style-type: none"> <li>• Reduce the input level of the control unit</li> <li>• Reduce the distance between control unit and microphone units</li> <li>• Remove obstacles between microphone units and antennae; do not place any objects in front of the antennae of the control unit</li> </ul>
Short drop-outs	<ul style="list-style-type: none"> <li>• Interferences caused by devices such as Wireless LAN</li> </ul>	<ul style="list-style-type: none"> <li>• Select another frequency band with the Quinta Conference Software, Quinta Web Server or via the push-button for RF frequency band selection on the front of the Quinta CU control unit. Refer also to chapter 7.1.</li> </ul>

## 7.1 Simultaneous Operation of the Quinta Conference System and other 2.4 GHz Devices (e.g. WLAN, Bluetooth)

### 7.1.1 Physical Laws

Due to many physical laws it is not possible to guarantee a simultaneous interference-free operation of different devices using the same frequency band. Radio devices operating in the same frequency band will always disturb each other (the function can be disturbed as well).

For the use of UHF wireless microphones it is known that 2 devices can never be operated on the same frequency. It is only possible to operate a certain number of compatible radio devices within a defined frequency band.

This applies also to the 2.4 GHz-ISM band (2400 MHz - 2484 MHz) or 5 GHz. Due to digital transmission techniques and various transmission standards it is possible, but not recommended, to operate certain devices simultaneously within the same frequency band.

### 7.1.2 Quinta and WLAN or WiFi

Like WLAN, the Quinta system uses the same bandwidth of approx. 22 MHz for each RF channel (Low, Mid, High). This results in three compatible RF channels which are theoretically:

- Compatible channel 1: 2400 MHz - 2428 MHz (theoretical mid frequency 2414 MHz)
- Compatible channel 2: 2428 MHz - 2456 MHz (theoretical mid frequency 2442 MHz)
- Compatible channel 3: 2456 MHz - 2484 MHz (theoretical mid frequency 2470 MHz)
- Compatible channel 4: +5.2 GHz - +5.8 GHz

The Quinta system uses RF channels (Low, Mid, High) compatible to each other. For WLAN the user has to configure compatible RF channels.

#### Frequencies Quinta / WLAN for example for 2.4 GHz

##### Quinta

Channel	Centre frequency		
	2.4 GHz	5.2 GHz	5.8 GHz
Low	2412 MHz	5180 MHz	5736 MHz
Mid	2438 MHz	5210 MHz	5762 MHz
High	2464 MHz	5240 MHz	5814 MHz

##### WLAN

Channel	Centre frequency
1	2412
2	2417
3	2422
4	2427
5	2432
6	2437
7	2442
8	2447
9	2452
10	2457
11	2462
12	2467
13	2472
14	2484

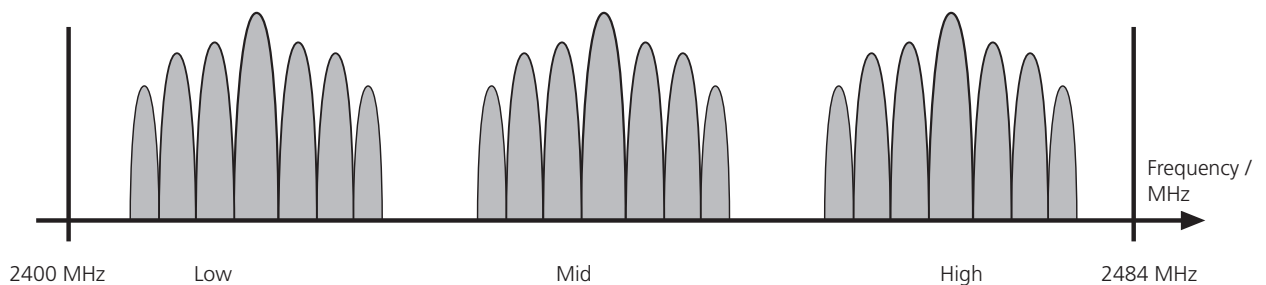

You can easily recognise that the individual WLAN channels overlap considerably due to their bandwidth. All neighbouring channels (e.g. channel 1 & 2 or channel 7 & 8) cannot be used simultaneously, because they would disturb each other. Furthermore, channel 12 and 13 are not approved for the use in the USA. In general, these channels are not used either. Within the remaining frequency bands only the WLAN channels 1, 6 and 11 can be used simultaneously.

For this reason the WLAN channels 1, 6 and 11 were selected for the RF channels Low, Mid and High used for the Quinta conference system. Due to this frequency compatibility the Quinta system is operated WLAN-friendly.

Due to careful frequency planning it is possible to operate one Quinta CU control unit with more than 4,000 microphone units and a maximum of two WLAN devices nearby simultaneously.

#### **More tips for installation**

- Keep a minimum distance of approx. 5 m between WLAN devices (e.g. Router, Repeater) and the transmitting and receiving antennae of the Quinta CU control unit.
- The distance between laptops with activated WLAN interface does not influence the audio transmission of the microphone units as long as there is no active data traffic.
- We recommend using different RF channels for WLAN or WiFi and Quinta channels. The distance between the WLAN and Quinta channels should be as large as possible.
- The channels of the Quinta conference system can be selected with the supplied Quinta Conference Software.

### **7.1.3 Quinta and Bluetooth**

- Bluetooth devices make use of the whole 2.4 GHz range with changing carrier frequencies (frequency hopping).
- Interferences caused by Bluetooth devices (including microwave ovens) in normal operation can be excluded due to different measures inside the Quinta conference system and an advanced transmission protocol.
- It cannot be excluded, however, that an existing Bluetooth data traffic will be interfered by Quinta.

### **7.1.4 Example for Quinta, Media Control System and WLAN**

**The 2.4 GHz technology is used for many applications in discussions and meetings.** In addition to a wireless discussion system other functions (light or volume control etc.) are operated via a wireless 2.4 GHz touch screen of a media control system. Furthermore, the participants of a meeting often have direct internet access via a WLAN access point.

The Quinta conference system and WLAN make use of compatible transmission standards. This should be considered when also using a media control system with a touch screen. State-of-the-art devices correspond to the WLAN standard.

1. Configure the Quinta conference system to the RF channel "Low". The Quinta system then makes use of the frequency range of 2401 to 2423 MHz. This frequency range must be reserved for Quinta exclusively.
2. Configure the touch screen of the media control system to the frequency range of 2426 to 2448 MHz. This corresponds to the WLAN channel 6. This frequency range must be reserved for the use of the touch screen exclusively.
3. Configure the WLAN access point to WLAN channel 11 making use of the frequency range 2451 to 2473 MHz. This frequency range must be reserved for the use by WLAN exclusively.
4. As an alternative you can operate Quinta in the 5.2 or 5.8 GHz band.

## 8. Components

Quinta CU	Control unit, DSSS transmission in 2.4 / 5.2 / 5.8 GHz ISM bands, 4 receive channels, 19" housing, 1 U, incl. 2 angled rod antennae, matt black, with high-resolution OLED display . . . . .	Order # 723.924
Quinta MU23	Chairman microphone unit, removable Classis GM 31xQ gooseneck microphone (optional), DSSS transmission (Triple-RF-ISM-Band), incl. rechargeable battery, with loudspeaker and three buttons, soft touch paint, matt black . . . . .	Order # 723.932
Quinta MU22	Double delegate microphone unit, removable Classis GM 31xQ gooseneck microphone (optional), DSSS transmission (Triple-RF-ISM-Band), incl. rechargeable battery, with loudspeaker and two microphone buttons, soft touch paint, matt black. . . . .	Order # 723.940
Quinta MU21	Delegate microphone unit, removable Classis GM 31xQ gooseneck microphone (optional), DSSS transmission (Triple-RF-ISM-Band), incl. rechargeable battery, with loudspeaker and one microphone button, soft touch paint, matt black . . . . .	Order # 723.959
Quinta CC 2	Charging case for 10 Quinta MU 23/22/21 microphone units with GM 313/314/315 Q, consisting of: Quinta CT 2 top cover, Quinta CD 2 charger, Quinta CW 2 bottom with casters . . . . .	Order # 723.967
Quinta CC 2/600	Charging case for 10 Quinta MU 23/22/21 microphone units with Classis GM 316 Q, consisting of: Quinta CT 2 / 600 top cover, Quinta CD 2 charger, Quinta CW 2 bottom with casters . . . . .	Order # 724.580
CA 2458	Mains power adapter with charging function and DC power supply for one Quinta MU microphone unit . . . . .	Order # 723.983

## 9. Accessories

### Supplied Accessories

1 Power cable	
1 USB cable	
6 Phoenix terminal strips, 3-pin	
2 CA Q11 antennas	
1 Unlocking tool	
Quinta Conference Software for Control and Configuration. . . . .	Order # 723.991

### Optional

#### Quinta CU Control Unit

CA Q 13	Planar antenna, 2.4 - 5.8 GHz . . . . .	Order # 724.408
CA Q 14	Omnidirectional antenna for remote installation . . . . .	Order # 723.894
CA Q 30	Ecoflex system coaxial cable, sold per metre . . . . .	Order # 724.440
CA Q 31	Ecoflex system coaxial cable, 10 m [32.8 ft] . . . . .	Order # 724.416
CA Q 32	Ecoflex system coaxial cable, 20 m [65.6 ft] . . . . .	Order # 724.424

#### Gooseneck Microphones for the Quinta MU 23/22/21 Microphone Units

Classis GM 313 Q	Gooseneck microphone, condenser, cardioid, black, length 300 mm [11.81"], LED, 5-pin XLR connector, incl. wind shield . . . . .	Order # 724.203
Classis GM 314 Q	Gooseneck microphone, condenser, cardioid, black, length 400 mm [15.75"], LED, 5-pin XLR connector, incl. wind shield . . . . .	Order # 724.211
Classis GM 315 Q	Gooseneck microphone, condenser, cardioid, black, length 500 mm [19.69"], LED, 5-pin XLR connector, incl. wind shield . . . . .	Order # 724.238
Classis GM 316 Q	Gooseneck microphone, condenser, cardioid, black, length 600 mm [23.62"], LED, 5-pin XLR connector, incl. wind shield . . . . .	Order # 724.351

#### Quinta CC 2 | CC 2 / 600 Charging and Transport Case

Quinta CD 2	Charger for 10 Quinta MU 23/22/21 microphone units. . . . .	Order # 723.975
Quinta CM 2	19" compartment for Quinta CU control unit. . . . .	Order # 724.661
Quinta CS 2	Empty compartment for Quinta CU control unit or accessories . . . . .	Order # 724.688
Quinta CT 2	Top cover . . . . .	Order # 724.556
Quinta CT 2/600	Top cover, when using the microphone units with the Classis GM 316 Q microphone. . . . .	Order # 724.580

## 10. Technical Specifications

### General

Frequency range	2400 – 2483.5 MHz 5150 – 5250 MHz 5725 – 5875 MHz
Modulation	Direct Sequence Spread Spectrum DSSS (2.4 GHz; 5.8 GHz); Orthogonal Frequency Division Multiplexing OFDM (5.2 GHz) digital signal processing acc. to own standard
Max. number of audio streams	4 useable channels per system
Signal-to-noise ratio	80 dB typ., (unweighted signal-to-noise ratio)
Range between microphone units and control unit	> 100 m [109.36 yds]
Power supply	100 – 240 V AC 50/60 Hz
Approval	world-wide

### AVB

Transmission and reception of audio data	acc. to IEC 61883-6
Format of the audio data	AM824
Stream ID Quinta CU	Bit 63 – 16 / MAC address Bit 15 – 0 / X

### Quinta MU Microphone Units

Transmitter power	max. 20 dBm per channel and region (average, duty cycle $\leq$ 30%)*
Battery voltage	8 NiMH cells, 2080 mAh
External DC operation	15 V DC ( $\pm 0.5$ V), residual hum < 20 mV, 950 mA
Charging time with charger with mains charger adapter	max. 2.5 hours when the battery is completely empty max. 2.5 hours when the battery is completely empty
Loudspeaker	Wide-band, integrated loudspeaker
Volume decrease when Mic On ("Ducking")	15 dB fixed setting
Headphone output	Jack socket (3.5 mm, stereo)
Min. impedance	16 $\Omega$
Power supply	9.6 V with integrated NiMH battery (8 cells)
Operating time depending on the type of the microphone unit	approx. 20 hours in discussion mode, operating time also depends on the volume
Temperature range (at < 90% humidity)	+10° – +40°C [+50 °F – +104 °F]
Storage temperature (at < 90% humidity)	-20° – +55°C [-4 °F – +131 °F]
Dimensions (without microphone)	
Length	173 mm [6.8"]
Width	157 mm [6.18"]
Height	51 mm [2.01"]
Weight	1.7 kg [3.74 lbs]

### Quinta CU Control Units

Frequency response	70 Hz – 22 kHz (-3 dB)
Operation mode	Diversity (receiver), separate for each channel
Antenna connection	2 N-connectors (female)
Transmitting power	max. 20 dBm per channel and region (average, duty cycle $\leq$ 30%)*
Connections	
Serial control port	RS 232, USB
Ethernet port	LAN, TCP/IP standard
Master output balanced	1 x XLR, 1 x 3-pin Phoenix terminal strip, max. +6 dBu, level adjustable via software (range $\pm 15$ dB)
Master output unbalanced	RCA, max. +2.2 dBu, level adjustable via software (range $\pm 15$ dB)
Audio outputs, single channels	4 x 3-pin Phoenix terminal strip, max. +6 dBu, level adjustable via software (range 0 ... -50 dB)
Input balanced	1 x 3-pin Phoenix terminal strip, max. +6 dBu, input adjustable via software (range 0 ... -50 dB)
Power supply	100 – 240 V AC 50/60 Hz 70 – 150 mA
Fuse	2 x AL 0.5 A (slow blow)
Power consumption	10 VA
Temperature range	+10° – +40 °C [+50 °F – +104 °F] (at < 90% humidity)
Indication	4 channel LEDs (red/white) and Power LED (red/white)
Min. depth of Rack	380 mm
Dimensions (W x H x D)	19", 1HU (440 x 44 x 239 mm) [17.32" x 1.73" x 9.41"]
Weight	3.2 kg [7.05 lbs]

## AVB interface:

MAC address	00:22:BB:00:FF:FF
Stream Suffix	00:00
Stream ID	00:22:BB:00:FF:FF:00:00
Number of channels	4
Audio format	IEC 61883-6/AM824 with 24-bit / 48 kHz
IP configuration	DHCP

**Quinta CD 2 Charger**

Power supply	100 - 240 V AC ~, 50 / 60 Hz
Fuse at the mains socket	2 x 6.3 A (slow blow)
Power consumption	max. 180 W
Max. ambient temperature when charging (< 90% atmospheric humidity)	+10 °C – +40 °C [+50 °F – +104 °F]
Storage temperature	-20 °C – +55 °C [-4 °F – +131 °F]
Charging unit	10 microphone units parallel
Charging time	max. 3.5 hours when the battery is completely empty
Dimensions (W x H x D)	757 x 476 x 370 mm [29.8" x 18.74" x 14.57"]
Weight	approx. 12 kg

**CA 2458 Mains Power Adapter**

Voltage	15 V DC
Current carrying capacity	1.6 A
Input voltage	100 – 240 V AC 50/60 Hz
Connector	Adapter for Europe, USA, UK, Australia

\*The transmitter power can differ from this value due to specific regulations in various countries.

## EC-DECLARATION OF CONFORMITY

**Application of  
Council directive:**

1999/5/EC  
R&TTE Directive

93/68/EEC  
Electromagnetic Compatibility

2006/95/EC  
Low Voltage Directive

**Standards to which  
Conformity is Declared:**

EMC	EN 301 489-1	V1.8.1
	EN 301 489-17	V2.1.1
Radio Spectrum	EN 300 328	V1.8.0
	EN 301 893	V1.5.1
	EN 300 440-1	V1.6.1
	EN 300 440-2	V1.4.1
Safety	EN 60 950-1	

**Manufacturer's Name:**

beyerdynamic GmbH & Co. KG

**Manufacturer's Address:**

Theresienstraße 8, 74072 Heilbronn, Germany

**Type of Equipment:**

Wireless Conference System  
**Quinta**

**Model Numbers:**

Quinta CU

I, the undersigned, as an employee of beyerdynamic, hereby declare that the equipment specified conforms to the above Directive and Standards.

Manufacturer's Signature:



Date:



1<sup>st</sup> June, 2012

Full Name:

Ulrich Roth

Position:

Director of R&D

 0682 



## EC-DECLARATION OF CONFORMITY

**Application of  
Council directive:**

1999/5/EC  
R&TTE Directive

93/68/EEC  
Electromagnetic Compatibility

2006/95/EC  
Low Voltage Directive

**Standards to which  
Conformity is Declared:**

EMC	EN 301 489-1	V1.8.1
	EN 301 489-17	V2.1.1
Radio Spectrum	EN 300 328	V1.8.0
	EN 301 893	V1.5.1
	EN 300 440-1	V1.6.1
	EN 300 440-2	V1.4.1
Safety	EN 60 950-1	

**Manufacturer's Name:**

beyerdynamic GmbH & Co. KG

**Manufacturer's Address:**

Theresienstraße 8, 74072 Heilbronn, Germany

**Type of Equipment:**

Wireless Conference System  
**Quinta**

**Model Numbers:**

Quinta MU21, Quinta MU22, Quinta MU23

I, the undersigned, as an employee of beyerdynamic, hereby declare that the equipment specified conforms to the above Directive and Standards.

Manufacturer's Signature:



Date:



1<sup>st</sup> June, 2012

Full Name:

Ulrich Roth

Position:

Director of R&D

 0682 

## FCC Regulation

FCC ID: OSDQUINTACU for Quinta CU  
FCC ID: OSDQUINTAMU2X for Quinta MU21  
FCC ID: OSDQUINTAMU2X for Quinta MU22  
FCC ID: OSDQUINTAMU2X for Quinta MU23

Canada: IC: 3628A-QUINTACU for Quinta CU  
Canada: IC: 3628A-QUINTAMU2X for Quinta MU21  
Canada: IC: 3628A-QUINTAMU2X for Quinta MU22  
Canada: IC: 3628A-QUINTAMU2X for Quinta MU23

### Part 15.19 Statement

#### NOTICE:

This device complies with Part 15 of the FCC Rules [and with RSS-210 of Industry Canada].

Operation is subject to the following two conditions:

- (1) this device may not cause harmful interference, and
- (2) this device must accept any interference received, including interference that may cause undesired operation.

### Part 15.21 Statement

#### NOTICE:

Changes or modifications made to this equipment not expressly approved by (manufacturer name) may void the FCC authorization to operate this equipment.

### Part 15.105 Statement

**NOTE:** This equipment has been tested and found to comply with the limits for a Class B digital device, pursuant to Part 15 of the FCC Rules. These limits are designed to provide reasonable protection against harmful interference in a residential installation. This equipment generates, uses and can radiate radio frequency energy and, if not installed and used in accordance with the instructions, may cause harmful interference to radio communications. However, there is no guarantee that interference will not occur in a particular installation. If this equipment does cause harmful interference to radio or television reception, which can be determined by turning the equipment off and on, the user is encouraged to try to correct the interference by one or more of the following measures:

- Reorient or relocate the receiving antenna.
- Increase the separation between the equipment and receiver.
- Connect the equipment into an outlet on a circuit different from that to which the receiver is connected.
- Consult the dealer or an experienced radio/TV technician for help.

### RF Exposure Statement

#### Radiofrequency radiation exposure Information:

This equipment complies with FCC radiation exposure limits set forth for an uncontrolled environment.

This equipment should be installed and operated with minimum distance of 20 cm between the radiator and your body.

This transmitter must not be co-located or operating in conjunction with any other antenna or transmitter.

**beyerdynamic))))**

beyerdynamic GmbH & Co. KG  
Theresienstr. 8 | 74072 Heilbronn – Germany  
Tel. +49 (0) 7131 / 617 - 0 | Fax +49 (0) 7131 / 617 - 204  
info@beyerdynamic.de | www.beyerdynamic.com

For further distributors worldwide, please go to [www.beyerdynamic.com](http://www.beyerdynamic.com)

