

Radiometrix

Issue E, 3rd December 1998

TX2 & RX2

UHF FM Data Transmitter and Receiver Modules

The TX2 and RX2 data link modules are a miniature PCB mounting UHF radio transmitter and receiver pair which enable the simple implementation of a data link at upto 40 kbit/s at distances upto 75 metres in-building and 300 metres open ground.

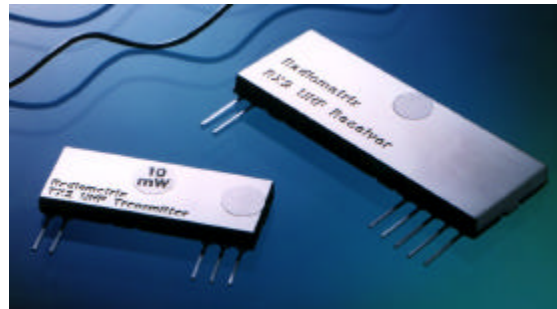

left: TX2 transmitter

right: RX2 receiver

Features:

- EMC conforms to ETS 300-683
- Type Approved to ETS 300-220
- Data rates to 40 kbps
- Usable range to 300 m
- 418 & 433.92 MHz versions.
- Fully screened

Available for operation at 433.92 MHz in Europe, 418.00 MHz and 433.92 MHz in the U.K., both modules combine full screening with extensive internal filtering to ensure EMC compliance by minimising spurious radiations and susceptibilities. The TX2 and RX2 modules will suit one-to-one and multi-node wireless links in applications including car and building security, EPOS and inventory tracking, remote industrial process monitoring and computer networking. Because of their small size and low power requirements, both modules are ideal for use in portable, battery-powered applications such as hand-held terminals.

Transmitter - TX2

- 2 stage SAW controlled, FM modulated at upto 40 kbps
- Operation from 2.2V to 6V
- +9dBm on 433.92MHz (Europe & UK) , -6dBm on 418MHz (UK)
- High efficiency, >15% , DC → RF
- Improved frequency and deviation accuracy
- 2nd harmonic, < -60dBc

Receiver - RX2

- Double conversion FM superhet
- SAW front end filter, image rejection 50dB
- Supply 3.0V to 6.0V @ 13mA
- 40kbps, -F version , -100 dBm sensitivity @ 1ppm BER
- 14kbps. -A version , -107 dBm sensitivity @ 1ppm BER
- LO leakage, < -60 dBm

Functional description:

The TX2 transmitter module is a two stage, SAW controlled FM transmitter operating between 2V and 6V and is available in 433.92MHz and 418.00 MHz versions. The 433.92 MHz unit is type-approved to ETS 300-220 for European use and delivers nominally +9dBm from a 5V supply at 12mA, while the 418.00 MHz unit has MPT 1340 type-approval for U.K. use and delivers -3dBm from a 5V supply at 5mA. Both modules measure 12 x 32 x 3.8 mm.

The RX2 module is a double conversion FM superhet receiver capable of handling data rates of upto 40kbit/s. The SIL style RX2 receiver measures 17.5 x 48 x 4.5 mm. It will operate from a supply of 3-6V and draws 14mA when receiving. A fast-acting carrier detect and a power-up enable time of less than 1ms This allows effective duty cycle power saving and a -107 dBm sensitivity. This, combined with a SAW front-end filter results in an excellent RF performance and EMC conformance.

TX2 transmitter:

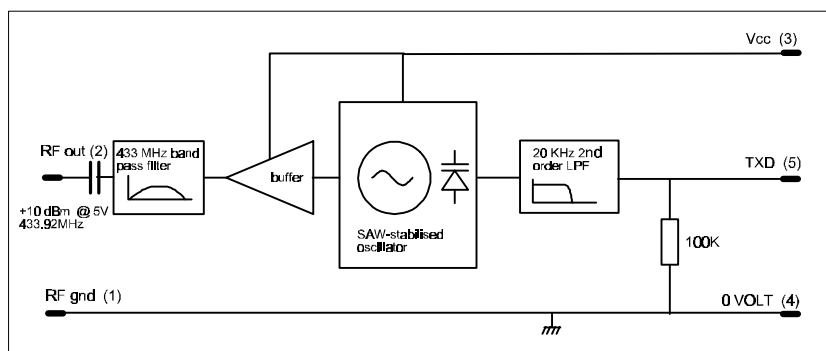

fig. 1: TX2 block diagram

Pin description:

RF GND (pin 1)

RF ground pin, internally connected to the module screen and pin 4 (0V). This pin should be connected to the RF return path (e.g. coax braid, main PCB ground plane etc.)

RF out (pin 2)

50Ω RF output to the antenna, it is DC isolated internally. (see antenna section of TX2 applications note for suggested antenna/feeds).

Vcc (pin 3)

+ve supply pin. The module will generate RF when the Vcc supply is present. Max ripple content 0.1V_{P-P}. A 100nF de-coupling ceramic capacitor is suggested.

0V (pin 4)

Supply ground connection, connected to pin 1 and screen.

TXD (pin 5)

This DC coupled modulation input will accept either serial digital data (0V to Vcc levels) or high level linear signals. see TX2 applications note for suggested drive methods. Input impedance is 100kΩ.

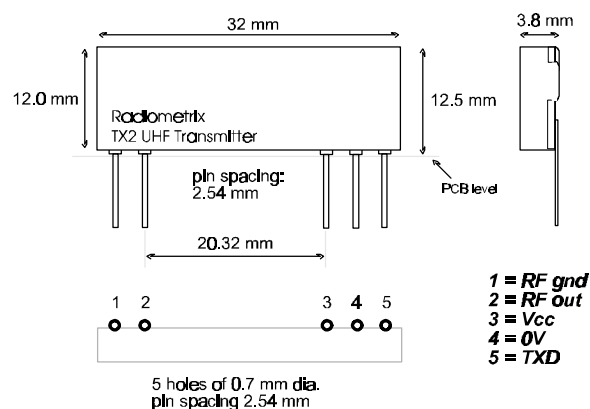

fig.2: physical dimensions

RX2 receiver:

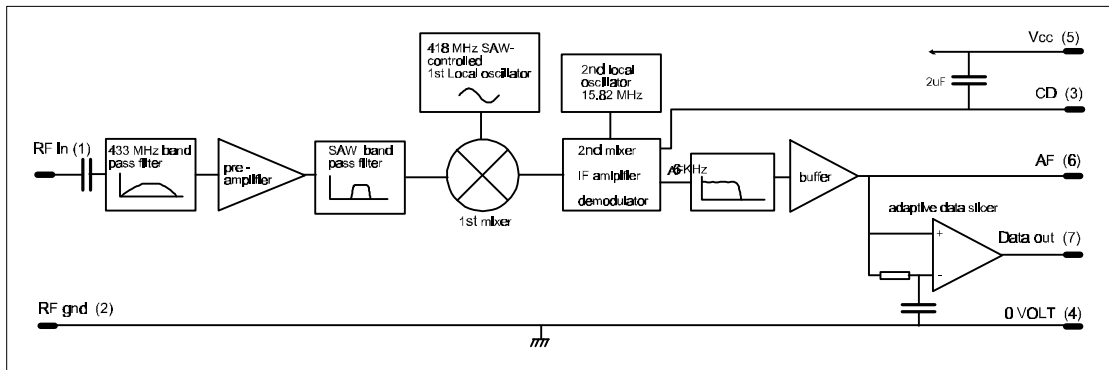

fig. 3: RX2 block diagram

Pin description

RF in (pin 1)
50Ω RF input from the antenna, it is DC isolate internally. (see antenna section of RX2 applications note for suggested antenna/feeds).

RF GND (pin 2)
RF ground pin, internally connected to the module screen and pin 4 (0V). This pin should be connected to the RF return path (e.g. coax braid, main PCB ground plane etc.)

CD (pin 3)
The Carrier Detect may be used to drive an external PNP transistor to obtain a logic level carrier detect signal, see test circuit / applications note. If not required it should be connected to pin 5 (Vcc).

0volt (pin 4)
Supply ground connection, connected to pin 1 and screen.

Vcc (pin 5)
+ve supply pin. +3.0V to +6.0V @ <17mA . The supply must be clean < 2mV_{P-P} ripple. A 10μF de-coupling capacitor and 10Ω series resistor is recommended if a clean supply is not available.

AF (pin 6)
This is a buffered and filtered analogue output from the FM demodulator. It has a standing DC bias of 1.2V and 400mV_{P-P} base band signal. It is useful as a test point or to drive linear decoders. Load impedance should be > 2kΩ and < 100pF.

RXD (pin 7)
This digital output from the internal data slicer is a squared version of the signal on pin 6 (AF). It may be used to drive external decoders. The data is true data, i.e. as fed to the transmitter. Load impedance should be > 1kΩ and < 1nF

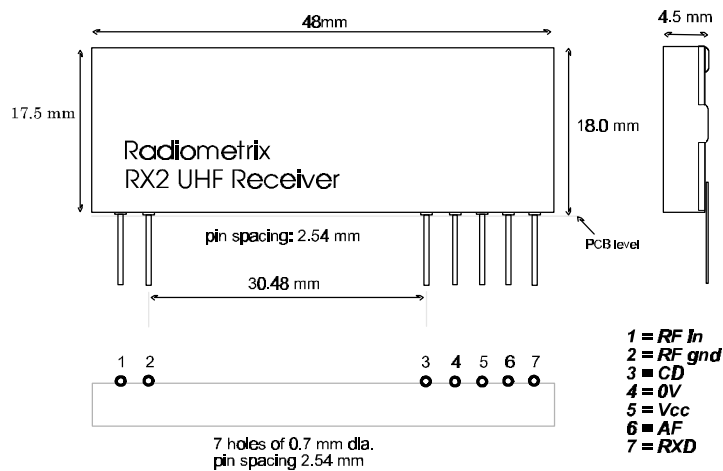

fig. 4: physical dimensions

Survival Maximums:

Operating temperature: -10°C to +55°C
 Storage temperature : -40°C to +100°C

TX2, all variants

Vcc (pin 3) -0.1V to +10.0V
 Data input (pin 5) -0.1V to +10.0V
 RF out (pin 2) ±50V @ < 10MHz , +20dBm @ > 10MHz

RX2, all variants

Vcc (pin 5) -0.1V to +10.0V
 Data , CD & AF (pin 7,3,6) -0.1V to + Vcc V
 RF input (pin 1) ±50V @ < 10MHz , +13dBm @ > 10MHz

note: Operation of the TX2 above 6V may cause the module to exceed the licensed power level.

Electrical Performance: TX2 transmitter

	pin	min.	typ.	max.	units	notes
DC LEVELS						
supply voltage	3	2.2	3.0	4.0	V	-3V version
supply voltage	3	4.0	5.0	6.0	V	-5V version
CURRENT & RF POWER						
<i>TX2-418-3V</i>						
supply current @ Vcc = 3V	3	4	6	10	mA	
RF power @ Vcc = 3V	2	-7	-3	+3	dBm	1
<i>TX2-418-5V</i>						
supply current @ Vcc = 5V	3	4	6	10	mA	
RF power @ Vcc = 5V	2	-7	-3	+3	dBm	1
<i>TX2-433-3V</i>						
supply current @ Vcc = 3V	3	4	6	10	mA	
RF power @ Vcc = 3V	2	0	+4	+6	dBm	1
<i>TX2-433-5V</i>						
supply current @ Vcc = 5V	3	7	10	14	mA	
RF power @ Vcc = 5V	2	+6	+9	+12	dBm	1
RF						
2 nd harmonic	2	-	-65	-54	dBc	1
harmonics @ > 1GHz	2	-	-50	-40	dBc	1
initial frequency accuracy	-	-30	0	+30	kHz	
overall frequency accuracy	-	-70	-	+70	kHz	
FM deviation (+/-)	-	20	25	30	kHz	
modulation bandwidth @ -3dB	-	DC	-	20	kHz	
modulation distortion (THD)	-	-	5	10	%	
power up time to full RF	-	-	-	100	µs	

note: 1. Measured into a 50Ω load.

Electrical Performance: RX2 Receiver

Unless otherwise noted:

Figures apply to 5V versions unless noted otherwise
Vcc = 5.0V, temperature 20°C unless noted otherwise

	pin	min.	typ.	Max.	units	notes
DC LEVELS						
supply voltage, Vcc standard	5	4.0	5.0	6.0	V	
supply voltage, Vcc, 3V version	5	3.0	3.5	4.0	V	
supply current	5	11	13	17	mA	
supply ripple	5	-	-	2	mV _{P-P}	1
data output high, 100µA source	7	-	Vcc-0.6	-	V	
data output low, 100µA sink	7	-	0.4	-	V	
load capacitance on AF / Data	6,7	-	-	100	pF	
RF						
RF sensitivity for 10dB (S+N)/N	1,6	-	-113	-107	dBm	-A version
RF sensitivity for 10dB (S+N)/N	1,6	-	-107	-100	dBm	-F version
RF sensitivity for 1ppm BER	1,6	-	-107	-100	dBm	-A version
RF sensitivity for 1ppm BER	1,6	-	-100	-93	dBm	-F version
CD threshold	1,3	-	-107	-97	dBm	-A version
CD threshold	1,3	-	100	-90	dBm	-F version
IF band width	-	-	250	-	kHz	
initial frequency accuracy	1	-30	0	+30	kHz	
E.M.C.						
image rejection (2*F _{IF})	1	-	-50	-	dB	2
spurious responses upto 1GHz	1	-	-70	-	dB	2
LO leakage, conducted	1	-	-65	-	dBm	
LO leakage, radiated	-	-	-70	-	dBm	
AF BASE BAND						
baseband bandwidth @ -3dB	6	0.006	-	7	kHz	-A version
baseband bandwidth @ -3dB	6	0.060	-	20	kHz	-F version
AF level	6	-	450	-	mV _{P-P}	
DC offset on AF	6	0.8	1.2	1.6	V	
distortion on recovered AF	6	-	0.5	1	%	
ultimate (S+N)/N	6	35	45	-	dB	
DYNAMIC TIMING						
<i>Power up with signal present</i>						
power up to valid CD, T _{PU-CD}	-	-	1	-	ms	
power up to stable data, T _{PU-DAT}	-	-	20	-	ms	-A version
power up to stable data, T _{PU-DAT}	-	-	5	-	ms	-F version
<i>Signal applied with supply on</i>						
signal to valid CD, T _{SIG-CD}	-	-	0.5	-	ms	
signal to stable data, T _{SIG-DAT}	-	-	15	-	ms	
signal to stable data, T _{SIG-DAT}	-	-	3	-	ms	
time between data transitions	7	15	-	0.07	ms	4,-A version
time between data transitions	7	1.5	-	0.025	ms	4,-F version
mark:space ratio	-	20	50	80	%	3

notes:

1. For 6dB (S+N)/N degradation on wanted -100dBm signal
2. Receiver spurious responses are at F_{RF} ± (n×15.92MHz), n=1,2,3 etc.
3. Average over 30ms (-A), 3ms (-F) at maximum bit rate.
4. Values for 50:50 mark to space (i.e. square wave)

Module test circuits

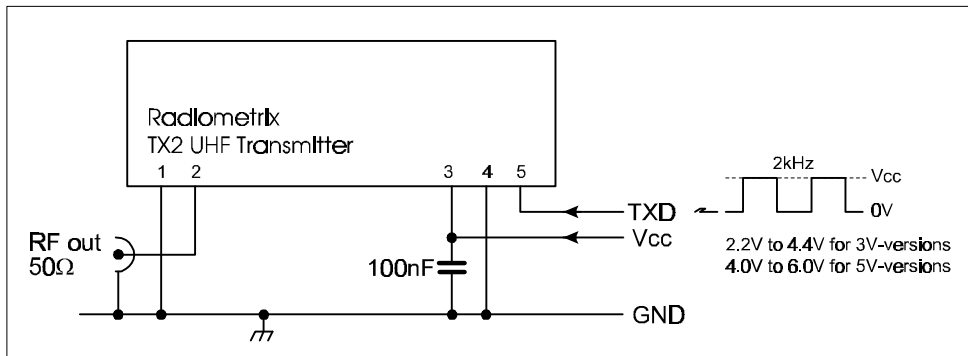

fig.5: TX2 test circuit

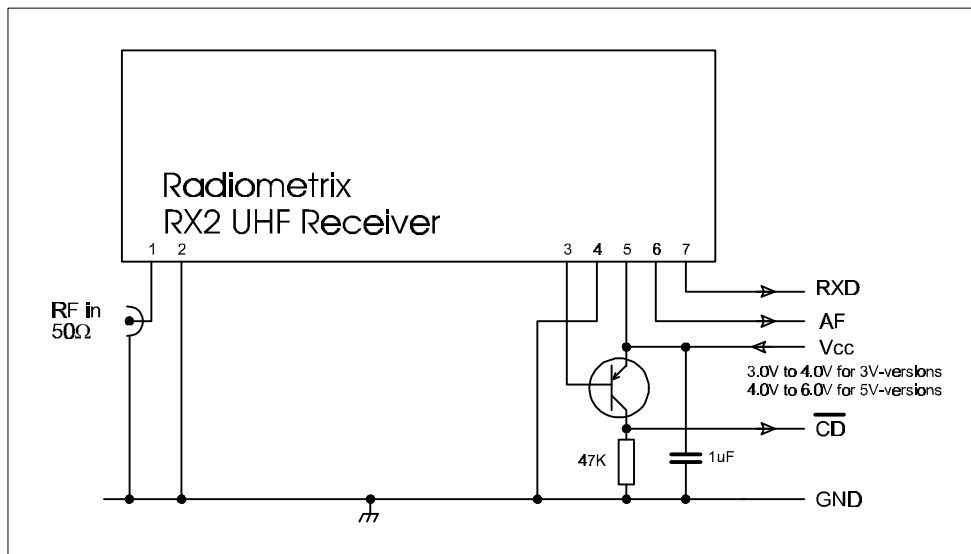

fig.6: RX2 test circuit

- * The PNP transistor enables a CMOS compatible Carrier Detect signal to be derived from pin 3. If no CD signal required pin 3 should be connected directly to pin 5 (Vcc)

Module mounting considerations

The modules may be mounted horizontally or vertically on an area of ground plane preferably close to the antenna to minimise feed length. The receiver and it's antenna should be kept away from sources of interference (micro's, SMPS etc.). The modules may be potted if required in a viscous compound which can not enter the screen can..

Warning: Do NOT wash the modules. They are not hermetically sealed.

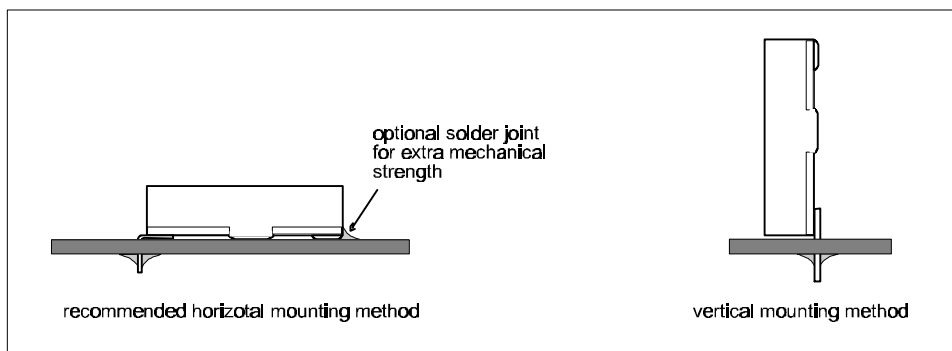

fig. 7: module mounting options

Antenna requirements

Three types of integral antenna are recommended and approved for use with the module:

- A) *Helical* Wire coil, connected directly to pin 2, open circuit at other end. This antenna is very efficient given it's small size (20mm x 4mm dia.). The helical is a high Q antenna, trim the wire length or expand the coil for optimum results. The helical de-tunes badly with proximity to other conductive objects.
- B) *Loop* A loop of PCB track tuned by a fixed or variable capacitor to ground at the 'hot' end and fed from pin 2 at a point 20% from the ground end. Loops have high immunity to proximity de-tuning.
- C) *Whip* This is a wire, rod, PCB track or combination connected directly to pin 2 of the module. Optimum total length is 17cm (1/4 wave @ 418MHz) Keep the open circuit (hot) end well away from metal components to prevent serious de-tuning. Whips are ground plane sensitive and will benefit from internal 1/4 wave earthed radial(s) if the product is small and plastic cased

	A	B	C
	helical	loop	whip
Ultimate performance	**	*	***
Easy of design set-up	**	*	***
Size	***	**	*
Immunity proximity effects	**	***	*
Range open ground to similar antenna (for TX2-433-A & RX2-433-A)	200m	100m	300m

Antenna selection chart

The antenna choice and position directly controls the system range. Keep it clear of other metal in the system, particularly the 'hot' end. The best position by far, is sticking out the top of the product. This is often not desirable for practical/ergonomic reasons thus a compromise may need to be reached. If an internal antenna must be used try to keep it away from other metal components, particularly large ones like transformers, batteries and PCB tracks/earth plane. The space around the antenna is as important as the antenna itself.

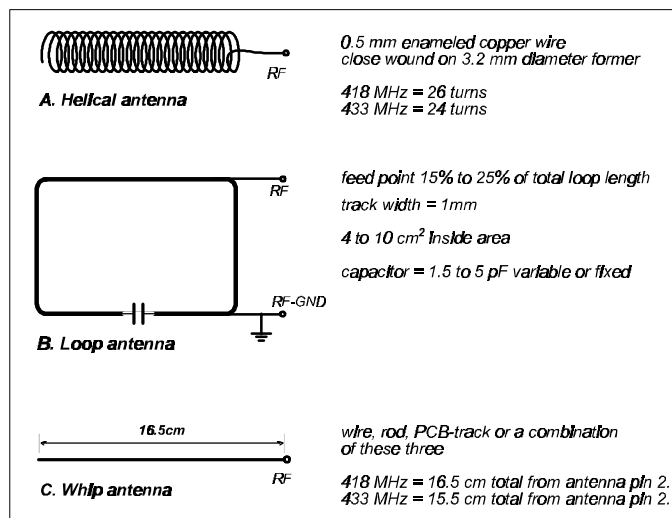

Fig.8: antenna configurations

Type Approval in UK

The TX2-418 is type approved in the UK to MPT1340 for use in Telemetry, Telecommand and In-Building alarm applications.

CONFORMANCE to MPT1340 REQUIRES THAT:

1. The transmitting antenna must be one of the 3 variants given in the data sheet. Antenna structures which yield ERP gain are not permitted.
2. The module must be directly and permanently connected to the transmitting antenna without the use of an external feeder. Increasing the RF power level by any means is not permitted.
3. The module must not be modified nor used outside it's specification limits.
4. The module may only be used to send digital or digitised data. Speech and/or music are not permitted.
5. The equipment in which the module is used **must** carry an inspection mark located on the outside of the equipment and be clearly visible. The minimum dimensions of the inspection mark shall be 10 x 15 mm and the letter and figure height must be no less than 2mm. The wording shall read:

RTD: xxxxxx
SRD-MPT1340-GB

6. Products intended for UK commercial application must be notified to the Radiocommunications Agency (RA) on form RA 249 (Cat I), obtainable from the RA's library service, Tel 0171 211 0502 / 0505

OEM Manufacturers incorporating the TX2 as a component part of their product are authorised by Radiometrix Ltd to quote our type-approval provided all the above conditions are complied with.

European type approval

The TX2-433 & RX2-433 are type approved to ETS 300-220 for European use.

CONFORMANCE to ETS 300-220 REQUIRES THAT:

1. The transmitting antenna must be one of the 3 variants given in the data sheet. Antenna structures which yield ERP gain are not permitted.
2. The module must be directly and permanently connected to the transmitting antenna without the use of an external feeder. Increasing the RF power level by any means is not permitted.
3. The module must not be modified nor used outside it's specification limits.
4. The equipment in which the module is used **must** carry an inspection mark located on the outside of the equipment and be clearly visible. The minimum dimensions of the inspection mark shall be 10 x 15 mm and the letter and figure height must be no less than 2mm. The wording shall read:

Radiometrix
TX2-433
CEPT-LPD-xx

respectively,

Radiometrix
RX2-433
CEPT-LPD-xx

5. It is not recommended to transmit carrier only. In Germany transmission may not be initiated without modulation.

OEM Manufacturers incorporating the TX2 & RX2 as a component part of their product are authorised by Radiometrix Ltd to quote our type-approval provided all the above conditions are complied with.

Most EEC member countries require notification before your product may be sold. We advise you to contact the relevant country.

Variants and Ordering information

The TX2 transmitter and RX2 receiver are manufactured in several variants

Frequencies 418.00 MHz for UK use
 433.92 MHz for UK & European use

Supply voltage 5V (4V to 6V TX2 & RX2)
 3V (3V to 4V for RX2, 2.2V to 4V for TX2)

RX data rate: -A, 7kHz baseband BW, slow data upto 14kbps
 -F, 20kHz baseband BW, fast data upto 40kbps

RX data rate applies to receivers only, the TX2 will handle fast or slow data.

The following are standard:

TX2-433: 433.92 MHz , 5V TX , +9dBm
TX2-418: 418.00 MHz , 5V TX , -6dBm

RX2-433-A: 433.92 MHz , 5 volt RX , 14kbps
RX2-433-F: 433.92 MHz , 5 volt RX , 40kbps
RX2-418-A: 418.00 MHz , 5 volt RX , 14kbps
RX2-418-F: 418.00 MHz , 5 volt RX , 40kbps

3V versions of the above are available and should be ordered with a -3V suffix on the part number. (e.g. RX2-433-A-3V is set-up for 3V to 4V operation)

Radiometrix Ltd.

**Hartcran House
Gibbs Couch
Carpenders Park
Watford
Hertfordshire
WD1 5EZ
England
tel: 0181 428 1220
fax: 0181 428 1221
Int ☎: +44 181 428 1220**

Internet

Our product information can also be found on the World Wide Web (WWW)

URL: **<http://www.radiometrix.co.uk/>**
e-Mail: **info@radiometrix.co.uk**

Copyright notice

This product data sheet is the original work and copyrighted property of Radiometrix Ltd. Reproduction in whole or in part must give clear acknowledgement to the copyright owner.

Limitation of liability

The information furnished by Radiometrix Ltd. is believed to be accurate and reliable. Radiometrix reserves the right to make changes or improvements in the design, specification or manufacture of its sub-assembly products without notice. Radiometrix does not assume any liability arising from the application or use of any product or circuit described herein, nor for any infringements of patents or other rights of third parties which may result from the use of its products. This data sheet neither states nor implies warranty of any kind, including fitness for any particular application. These radio devices may be subject to radio interference and may not function as intended if interference is present. We do NOT recommend their use for life critical applications

Radio and EMC regulations

*The Intrastat commodity code for all our modules is: 8542 4090.
The purchaser of Radiometrix sub-assemblies must satisfy all relevant EMC and regulations which applies to their finished products.*

(End of TX2 and RX2 data sheet)

Radiometrix Ltd

Worldwide Distributors

Radiometrix Ltd

Harteran House
Gibbs Couch
Carpenders Park
Hertfordshire
WD1 5EZ

ENGLAND

Tel: +44 (0)181 428 1220
Fax: +44 (0)181 428 1221
E-mail: radiometrix@dial.pipex.com
URL: <http://www.radiometrix.co.uk/>

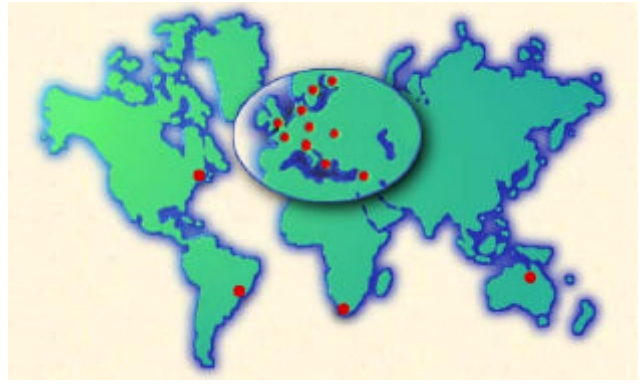

Telelink Communications

PO Box 5457, North Rockhampton, Queensland 4702,
AUSTRALIA
Tel: +61 7 49340413 Tel (24hr): +61 7 38300233
Fax: 61 7 49340311
E-mail: tlink@pronet.net.au

RS do Brasil Comp. Imp. Exp. Consultoria e Representacao Ltda.

Av. Brig. Faria Lima 2413 (antigo 1058), 6th floor, Sao Paulo, SP, 01451-001, **BRASIL**
Tel: +55 11 870 0429 Fax: +55 11 867 0009 or 815 1162
E-mail: Vendas@RsdoBrasil.com.br

Ginsbury Electronic A/S

Lerhoej 15, DK-2880 Bagsvaerd,
DENMARK
Tel : +45 44446666 Fax: +45 44446669
E-mail: Ginsbury@Ginsbury.dk

Ginsbury Electronique

3 rue nationale, 92140 Clamart, **FRANCE**
Tel : +33 1 49109933 Fax: +33 1 49109578
E-mail: mls@wylgins-fr.francenet.fr

Haril

2A Tsokopoulou St., 152 37 Filothei, Athens, **GREECE**
Tel : +30 1 6810338, Fax: +30 1 6853359
E-mail: Haril@acci.gr

RF Design

P.O. Box 18409, Wynberg, Cape Town, 7824,
SOUTH AFRICA
Tel: +27 21 762-5365, Fax: +27 21 797-1983
E-mail: sales@rfdesign.co.za

Telemeter Electronic AG

Im Gree 79, CH-8566, Ellighausen, **SWITZERLAND**
Tel: +41 71 699 2020 Fax: +41 71 699 2024,
E-mail: telemeter@swissonline.ch

IDVISION B.V.B.A

Augustijnenstraat 44, 8900 Ieper,
BELGIUM
Tel : +32 57216141 Fax: +32 57216434
E-mail: idvision@skynet.be

Advanced Radio Telemetry Ltd.

Francouzka 82, 602 00, BRNO,
CZECH REPUBLIC
Tel : +42 5 45211403 Fax : +42 5 45210506
E-mail: art@brno.bohem-net.cz

Wyle Ginsbury Electronics Oy

P.O. Box 121 (Sinikalliontie 3) FIN-02631 Espoo,
FINLAND
Tel : +358 9 5021500 Fax : +358 9 5021510
E-mail: antti.granlund@ginsbury.inet.fi

HY-LINE Communication Products GmbH

Inselkammerstr. 10, D-82008 Unterhaching,
GERMANY
Tel: +49 89 61450360 Fax: +49 89 6140960
E-mail: communication@hy-line.de

Gallium Electronics Ltd.

11 Hasadna St, P.O.B 2552, Ra'anana, 43650, **ISRAEL**
Tel : +972 9 7482182 Fax: +972 9 7484046
E-mail: beni.k@gallium.co.il

GINSBURY ELECTRONIC AB

Box 1200, Vintergatan 1, S-172 24 Sundbyberg,
SWEDEN
Tel : +46 8 296490 Fax : +46 8 296462
E-mail: info@ginsbury.se

Lemos International Co.Inc.,

65 Southbridge Street, Auburn, MA 01501, **USA**
Tel: +1 508 798 5004 Fax: +1 508 798 4782
E-mail: lemosint@ma.ultranet.com

