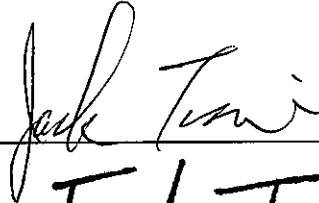



EXHIBIT B

Test Report

Report No.	T5415563	
Specifications	FCC Part 15.109(g), CISPR 22, Class B	
Test Method	ANSI C63.4 1992	
Applicant address	DP 34, NE WLY DEVELOPED PLOTS, SOUTH PHASE INDUSTRIAL ESTATE, GUINDY, CHENNAI, T.N. INDIA/600032	
Applicant	TVS ELECTRONICS LTD.	
Items tested	DOT MATRIX PRINTER	
Model No.	MSP-240 (Sample # T54563)	
Results	Compliance (As detailed within this report)	
Sample received date	03/30/2000 (month / day / year)	
Prepared by		project engineer
Authorized by		General Manager (Frank Tsai)
Issue date	April 29, 2000	(month / day / year)
Modifications	None	
Tested by	Training Research Co., Ltd.	
Office at	2, Lane 194, Huan-Ho Street, Hsichih, Taipei Hsien 221, Taiwan	
Open site at	No. 5-3, Lane 21, Yen Chiu Yuan Rd., Sec. 4, Taipei, Taiwan	

Conditions of issue:

- (1) *This test report shall not be reproduced except in full, without written approval of TRC. And the test result contained within this report only relate to the sample submitted for testing.*
- (2) *This report must not be used by the client to claim product endorsement by NVLAP or any agency of U.S. Government.*

★ **FCC ID: OSCMSP-240**

Contents

Chapter 1 Introduction

Description of EUT	3
Configuration of Test Setup	4
List of Support Equipment	5

Chapter 2 Conducted Emission Test

Test Condition and Setup	7
Conducted Test Placement	8

Chapter 3 Radiated Emission Test

Test Condition and Setup	9
Radiated Test Placement	10

Appendix A:

Conducted test result	11
-----------------------------	----

Appendix B:

Radiated test result	12
----------------------------	----

Chapter 1 Introduction

Description of EUT:

This device is printing data equipment. It is designed to connect with a personal computer via parallel port of PC.

Connections of EUT:

- (1) The power port of EUT is connected with AC power source.
- (2) The parallel port of EUT is connected with the parallel port of PC.

Test method:

Pretest was found that the emission of operating mode is worse than standby mode. So, The final test is made at the operating mode.

During testing, the EUT was operated at “*continuously printing*” mode. The test placement as the photographs showed is the worst case emission placed. (If the emission is close to the ambient, the resolution BW and view resolution will be reduced and the data will be recorded by detection of maximum hold peak mode.)

The testing configuration of test setup is showing in the next page.

Configuration of test setup

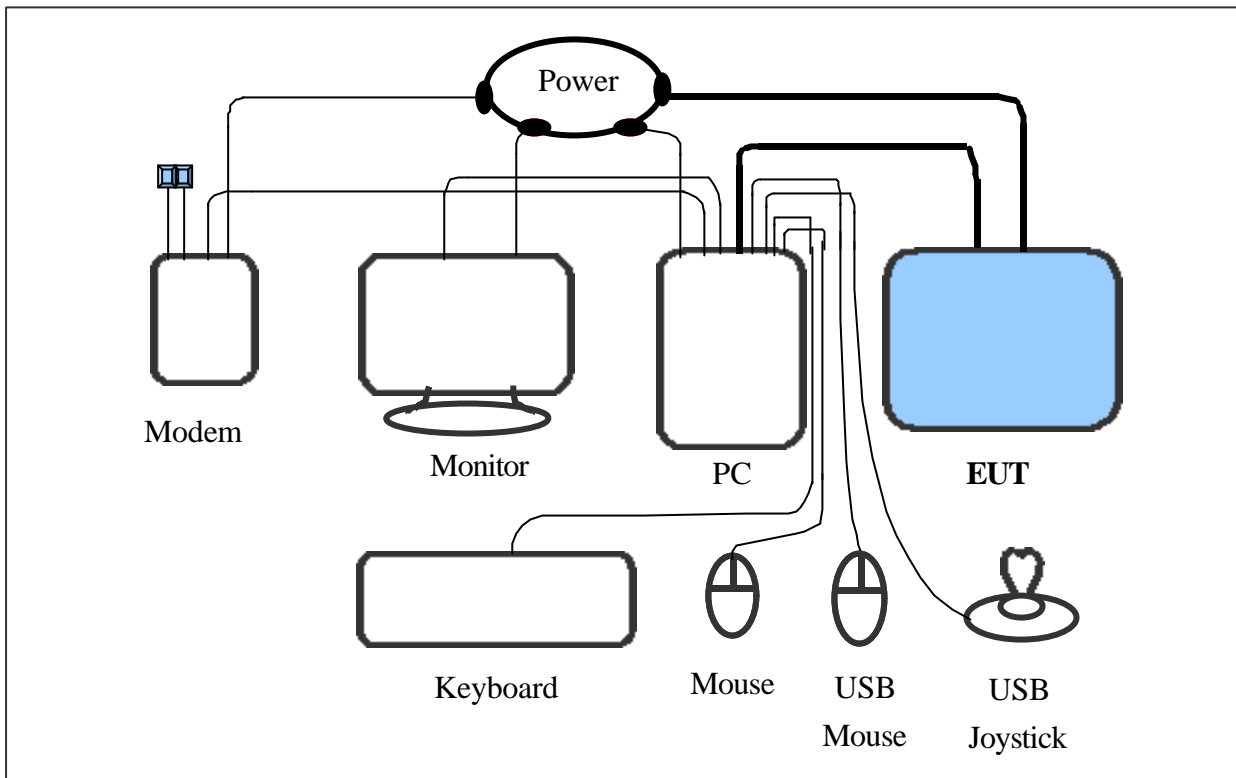

Connections:

PC:

- *Serial port --- via a 76cm shielded RS-232 cable to an external modem
 - *Printer port --- EUT
 - *Keyboard port --- a keyboard with 1.7m length data cable
 - *Mouse port --- a mouse with 1.88m length data cable
 - *Monitor port --- a monitor with 1.45m long of data cable
 - *USB port A --- a joystick with 1.5m long, shielded and no ferrite bead data cable
 - *USB port B --- a mouse with 1.5m long, shielded and no ferrite bead data cable
- (Each port on PC is connected with suitable device)

EUT:

- *Power Port --- via a 1.90m long, non-shielded, no ferrite bead, power cable to the AC power source
- *Parallel Port --- via a 1.40m long, shielded, no ferrite bead, data cable to the parallel port of person computer

List of support equipment

Conducted (Radiated) test:

PC : **HP Brio 85xx 6/350**
Model No. : D6928A
Serial No. : SG91801552
FCC ID : N/A, Doc Approved
檢磁 : 3872H013
Power type : 100 ~ 230VAC / 50 ~ 60Hz, 5A, Switching
Power cord : Non-shielded, 2.33m long, Plastic, No ferrite core

Monitor : **HP 15' Color Monitor**
Model No. : D2827A
Serial No. : KR91161719
FCC ID : C5F7NFCMC1518X
檢磁 : 3872B039
Power type : 110 ~ 240 VAC / 50 ~ 60 Hz, Switching
Power cord : Shielded, 1.83m long, No ferrite core
Data cable : Shielded, 1.46m long, with two ferrite cores

Keyboard : **HP**
Model No. : SK-2501K
Serial No. : MR80700789
FCC ID : GYUR38SK
檢磁 : 3862A621
Power type : By PC
Data cable : Shielded, 1.73m long, with ferrite core

Mouse : **HP**
Model No. : M-S34
Serial No. : LZB90714106
FCC ID : DZL211029
檢磁 : 4862A011
Power type : By PC
Power cord : Non-shielded, 1.88m long, No ferrite core

Modem : **ACEEX**
Model No. : XDM-9624
FCC ID : IFAXDM-9624
Power type : 220VAC, 50Hz / 9VAC, 1A
Power cord : Non-shielded, 1.9m long, No ferrite cord
Data cable : RS232, Shielded, 1.2m long, No ferrite core
RJ11C x 2, 7' long non-shielded, No ferrite core

USB Mouse : **Logitech**
Model No. : M-BA47
Serial No. : LZE92250027
FCC ID : N/A, Doc Approved
檢磁 : 4872A220, N/A
Power type : Powered by PC
Power Cable : Shielded, 1.5m long, Plastic hoods, No ferrite bead

USB Joystick : **Padix**
Model No. : QF-305U
Serial No. : N/A
FCC ID : N/A, Doc Approval
Power type : Powered by PC
Power Cable : Shielded, 1.5m long, No ferrite bead data cable

Chapter 2 Conducted emission test

Test condition and setup:

All the equipment is placed and setup according to the CISPR 22. The EUT is assembled on a wooden table that is 80 cm high, is placed 40 cm from the back-wall that is a vertical conducting plane. One LISN is for EUT, the other LISN is for support equipment. They are all placed on the conductive ground. The EUT's LISN connect a line switch box for selecting L1 or L2, then connect to a preamplifier and spectrum.

The spectrum scans from 150KHz to 30MHz. Conducted emission levels are detected at max. peak mode. But if the max. peak mode failed or over average limit, it will be measured by average detection mode.

While testing, there is the worst-emission plot printed at peak detection mode, and there are more than 6 highest emissions relative to limit recorded. The plot is kept as the original data, not included in test report.

List of test Instrument :

Instrument Name	Model No.	Brand	Serial No.	Calibration Date	
				Last time	Next time
Spectrum analyzer	8591EM	H P	3710A01203	01/29/00	01/29/01
LISN (EUT)	3825/2	EMCO	9411-2284	05/20/99	05/20/00
LISN (Support E.)	3825/2	EMCO	9210-2007	05/20/99	05/20/00
Preamplifier	8447F	H P	2944A03706	05/20/99	05/20/00
Line switch box	AC1-003	TRC	-----	05/20/99	05/20/00
Line selector	AC1-002	TRC	-----	05/20/99	05/20/00

The level of confidence of 95%, the uncertainty of measurement of conducted emission is ± 2.4 dB.

Test Result: Pass (Appendix A)

Conducted Test Placement: (Photographs)



Chapter 3 Radiated emission test

Test condition and setup :

Pretest : Prior to the final test (OATS test), the EUT is placed in a shielded enclosure, and scan from 30MHz to 1GHz. This is done to ensure the radiation exactly emits form the EUT.

Final test: Final radiation measurements are made on a **10 - meter**, open-field test site. The EUT is placed on a nonconductive table that is 0.8m height, the top surface is 1.0 x 1.5 meter. The placement is according to CISPR 22.

The spectrum is examined from 30 MHz to 1000 MHz measured by HP spectrum.

The M.E. whole range Antenna is used to measure frequency from 30 MHz to 1GHz. The final test is used the spectrum analyzer.

Measure more than six top marked frequencies generated form pretest by computer step by step at each frequency. The EUT is rotated 360 degrees, and antenna is raised and lowered from 1 to 4 meters to find the maximum emission levels. The antenna is used with both horizontal and vertical polarization.

Appropriated preamplifier that is made by TRC is used for improving sensitivity and precaution is taken to avoid overloading. The spectrum analyzer's 6dB bandwidth is set to 120 K Hz, and the EUT is measured at quasi-peak mode.

If the emission is close to the frequency band of ambient, the tester will recheck the data and the corrected data will be written in the test data sheet. If the emission is just within the ambient, the data from shielded room will be taken as the final data.

List of test Instrument :

<u>Instrument Name</u>	<u>Model No.</u>	<u>Brand</u>	<u>Serial No.</u>	<u>Calibration Date</u>	
				<u>Last time</u>	<u>Next time</u>
Spectrum analyzer	8591EM	H P	3619A00821	11/26/99	11/26/00
Spectrum analyzer	8568B	H P	3004A18617	05/18/99	05/18/00
Quasi-peak Adapter	85650A	H P	2521A00984	05/18/99	05/18/00
RF Pre-selector	85685A	H P	2947A01011	05/18/99	05/18/00
Antenna (30M-1.5G Hz)	VULB 9160	M.E.	3064	01/20/00	01/20/01
Open test side (Antenna, Amplify, cable calibrated together)				05/20/99	05/20/00

The level of confidence of 95% , the uncertainty of measurement of radiated emission is ± 4.96 dB .

Test Result : Pass (Appendix B)

Radiated Test Placement: (Photographs)

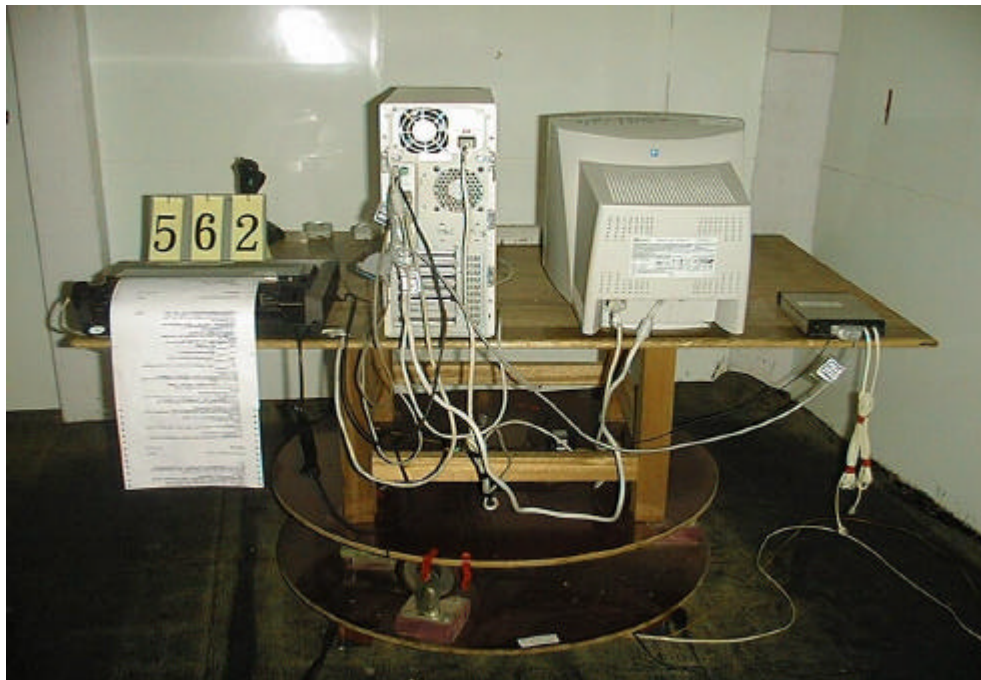

Appendix A

Conducted Emission Test Result:

Testing room : Temperature : 21 ° C Humidity : 68 % RH

Line 1

Frequency (KHz)	READING AMPLITUDE			LIMIT		Margin (dB)
	Peak (dBmV/m)	Quasi- Peak (dBmV/m)	Average (dBmV/m)	Quasi- Peak (dBmV/m)	Average (dBmV/m)	
226.00	49.90	***.**	***.**	63.83	53.83	-3.93
340.00	47.08	***.**	***.**	60.57	50.57	-3.49
455.00	39.67	***.**	***.**	57.29	47.29	-7.62
508.00	37.63	***.**	***.**	56.00	46.00	-8.37
608.00	40.14	***.**	***.**	56.00	46.00	-5.86
684.00	39.33	***.**	***.**	56.00	46.00	-6.67
793.00	36.92	***.**	***.**	56.00	46.00	-9.08
916.00	39.16	***.**	***.**	56.00	46.00	-6.84
997.00	37.90	***.**	***.**	56.00	46.00	-8.10
2590.00	38.06	***.**	***.**	56.00	46.00	-7.94

Line 2

Frequency (KHz)	READING AMPLITUDE			LIMIT		Margin (dB)
	Peak (dBmV/m)	Quasi- Peak (dBmV/m)	Average (dBmV/m)	Quasi- Peak (dBmV/m)	Average (dBmV/m)	
225.00	51.60	***.**	***.**	63.86	53.86	-2.26
340.00	43.03	***.**	***.**	60.57	50.57	-7.54
612.00	37.14	***.**	***.**	56.00	46.00	-8.86
684.00	38.02	***.**	***.**	56.00	46.00	-7.98
916.00	37.86	***.**	***.**	56.00	46.00	-8.14
2370.00	37.68	***.**	***.**	56.00	46.00	-8.32
2810.00	37.29	***.**	***.**	56.00	46.00	-8.71
14770.00	43.04	***.**	***.**	60.00	50.00	-6.96
17130.00	41.80	***.**	***.**	60.00	50.00	-8.20
19620.00	43.87	***.**	***.**	60.00	50.00	-6.13

*The reading amplitudes are all under average limit.

Appendix B

Radiated Emission Test Result: (Horizontal)

Test Conditions:

Testing room : Temperature : 23 ° C Humidity : 68 % RH
 Testing site : Temperature : 23 ° C Humidity : 80 % RH

Frequency	Reading Amplitude	Ant. Height	Table	Correction Factors	Corrected Amplitude	Class B Limit	Margin
MHz	dBµV	m	degree	dB/m	dBµV/m	dBµV/m	dB

153.380	32.20	1.00	298	-10.56	21.64	30.00	-8.36
240.000	39.70	4.00	54	-11.90	27.80	37.00	-9.20
336.000	33.80	4.00	232	-8.00	25.80	37.00	-11.20
415.680	36.10	2.57	76	-5.30	30.80	37.00	-6.20
480.000	25.90	4.00	107	-3.26	22.64	37.00	-14.36
498.820	26.80	2.57	8	-3.08	23.72	37.00	-13.28
528.000	27.80	4.00	334	-2.16	25.64	37.00	-11.36

Note:

1. Margin = Amplitude - limit, *if margin is minus means under limit.*
2. Corrected Amplitude = Reading Amplitude + Correction Factors
3. Correction factor = Antenna factor + (Cable Loss - Amplitude gain)
 (For example : 30MHz correction factor = 15.5 + (-15.26) = 0.24 dB/m)

Radiated Emission Test Result: (Vertical)

Frequency	Reading Amplitude	Ant. Height	Table	Correction Factors	Corrected Amplitude	Class B Limit	Margin
MHz	dB μ V	m	degree	dB/m	dB μ V/m	dB μ V/m	dB

39.310	33.70	1.00	278	-14.11	19.59	30.00	-10.41
85.040	28.20	4.00	118	-15.96	12.24	30.00	-17.76
96.000	38.60	2.57	253	-14.70	23.90	30.00	-6.10
127.740	34.70	1.00	151	-12.47	22.23	30.00	-7.77
154.760	23.40	4.00	59	-10.56	12.84	30.00	-17.16
162.130	24.50	2.57	40	-10.74	13.76	30.00	-16.24
240.000	33.40	4.00	198	-11.90	21.50	37.00	-15.50
336.000	27.70	4.00	133	-8.00	19.70	37.00	-17.30
415.680	32.90	4.00	25	-5.30	27.60	37.00	-9.40

Final statement:

This test report, measurements made by TRC are traceable to the NIST.