

Radio Modem M3090

Integrator's Manual

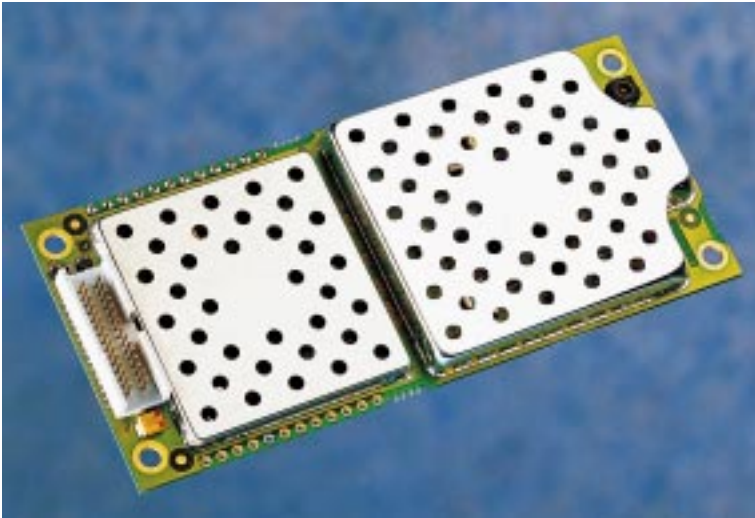

This document contains information proprietary to Ericsson Mobile Data Design AB.

No part of this publication may be reproduced, stored in a retrieval system, transmitted in any form by any means, including photocopying, electronic, mechanical, recording or otherwise, without the prior consent of the copyright holder.

First edition (September 1999)

This manual is published by Ericsson Mobile Data Design AB without any warranty. Improvements and changes in this manual due to typographical errors, inaccuracy of current information, or improvement of programs and/or equipment may be made by Ericsson Mobile Data Design AB at any time and without notice. Such changes will, however, be incorporated into new editions of this manual.

© Ericsson Mobile Data Design AB, 1999.

Publication number: 198 17 - KRD 102 303 Uen, Rev A.

Printed in Sweden

Mobitex is a trademark owned by Ericsson Mobile Data Design AB.

Contents

1	Safety advice and other precautions	1
1.1	Safety.....	1
1.2	Product care.....	2
2	About this Manual	3
2.1	Purpose of this Manual.....	3
2.2	Who Should Read this Manual?.....	3
2.3	How to Use this Manual.....	4
2.4	Questions and Comments.....	4
2.5	Terminology	5
2.6	References and Products	6
3	Introduction	7
3.1	The Mobitex Network	7
3.2	The M3090 Radio Modem	9
3.3	Host Communication	12
4	About Antennas	13
4.1	The Functions of an Antenna	13
4.2	Antenna Concepts	14
4.3	The M3090 Antenna	16
4.4	Antenna Suppliers	17
5	Technical Data.....	19
5.1	Physical Data.....	19
5.2	Connectors and Logical Interfaces.....	20
5.3	Power Supply	23
5.4	Environmental Specifications	26
5.5	Safety Specifications	28
5.6	Radio Specifications.....	29
5.7	External Antenna Specifications	30
6	Host Requirements	31
6.1	Host Environment	31
6.2	Integrator's Kit	32
6.3	Physical installation of the Radio Modem	33
6.4	Selecting an Antenna.....	37
6.5	Connecting the Antenna.....	37
6.6	Connecting the Radio Modem to the Host.....	38

7	Type Approval.....	39
7.1	Requirements in the USA.....	39

1 Safety advice and other precautions

The M3090 radio modem should be handled like any other mobile radio station. Therefore, you – the integrator – should read this information before integrating the modem with your application.

1.1 Safety

- The radio modem must not be used with or close to any medical life support equipment.
- Used in proximity to personal medical electronic devices, such as pacemakers or hearing aids, the modem may present a hazard. Make sure that use of the modem is permitted; as a rule, radio transmitters must be switched off at hospitals, on aeroplanes etc.
- The modem has no built-in fuse. To protect the power supply cables and fulfil fire safety requirements, a fuse should be mounted as close to the terminals of the power supply as possible.
- Never use the modem at a gas station, refuelling point, blasting area or other explosive environment.
- If the antenna is to be mounted outdoors, consider protection from lightning.

1.2 Product care

- Do not expose the radio modem to environmental or electrical loads beyond the limits specified in *chapter 5 "Technical Data"*. Any such exposure may damage the modem.
- Make sure to connect the antenna *before* the system connector. Operating the modem without an antenna may cause severe damage.
- Do not connect more than one modem to a single antenna. Radio frequency energy from the transmitter of one modem may damage another unit.
- Do not connect to the modem any component or product that is not compatible with the M3090 interface as specified in this manual. Ericsson does not warrant any defects, non-conformities and/or deviations caused by such a connection.
Mismatched external components, such as improperly made connections or incorrectly designed or installed antennas, may cause radiation limits to be exceeded, which could lead to malfunction in the modem or the host equipment.
- Operating the modem close to other electronic devices, such as antennas, television sets or radios, may cause electromagnetic interference.
- Do not place the modem close to magnetic storage media, such as credit cards, computer diskettes etc.
- Do not try to dismantle the modem, or you may lose your warranty. The modem does not have any user-serviceable components.

2 About this Manual

2.1 Purpose of this Manual

This manual describes the M3090 radio modem and defines what is required from the host equipment and the environment in which the modem is to be integrated.

The manual also provides technical data and background information about antennas and the Mobitex system.

2.2 Who Should Read this Manual?

This manual is intended for engineers in OEM companies who plan and implement the integration of the M3090 radio modem with various host equipment for operation in a Mobitex network.

It is assumed that the reader is familiar with the basics of radio and telecommunications technology.

In addition to this manual, most integration engineers will require the following to start up and test an integrated radio modem successfully:

- the MASC (Mobitex Asynchronous Communication Protocol) chapter in the Mobitex Interface Specification (MIS).
- an M3090 Integrator's Kit (from Ericsson).

2.3 How to Use this Manual

To get an understanding of the basics of a Mobitex network and the function of the M3090 radio modem, read *chapter 3 "Introduction"*.

Readers who are not familiar with the basics of antenna selection and design should also read *chapter 4 "About Antennas"*.

The following two, *chapter 5 "Technical Data"* and *chapter 6 "Host Requirements"*, contain information that is useful when planning the integration of the modem.

Information about type approval and type approval authorities, mainly in North America, is presented in *chapter 7 "Type Approval"*.

Finally, the *Index* lists items in alphabetical order, with references to page numbers.

2.4 Questions and Comments

If you have any questions or comments regarding the contents of this manual, please send them to:

Ericsson Mobile Data Design AB
Technical Assistance Centre
S:t Sigfridsgatan 89
S-412 66 Göteborg
SWEDEN
Fax: +46 31 703 6033
E-mail: mobitex.tac@erv.ericsson.se

2.5 Terminology

The following terminology is used in this manual:

- The M3090 wireless modem is called the *radio modem*.
- The data equipment which uses the radio modem to communicate with the radio base station is called the *host*.
- The data equipment and the radio modem, used as a single integrated unit, is called the *terminal*.
- An OEM company that integrates M3090 radio modems with various host equipment is called an *integrator*.

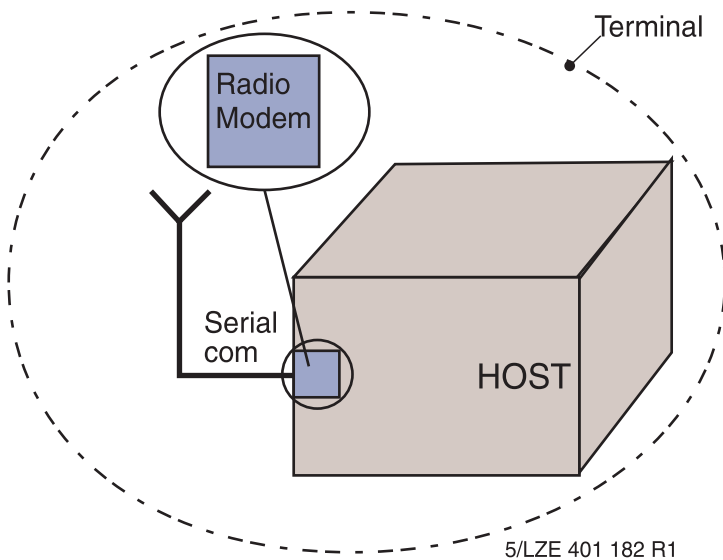

Figure 1 Terminology

2.6 References and Products

- Mobitex Interface Specification (MIS), LZBA 703 1001
- Data Communication over the telephone network. Recommendation V.24, CCITT, Fascicle VIII.I, 1988
- M3090 Product Description, AE/LZT 123 2070
- M3090 Integrator's Kit, KRY 901 46

3 Introduction

This chapter introduces the Mobitex system, the M3090 radio modem and the mode of communication between a radio modem and its host equipment.

3.1 The Mobitex Network

The M3090 radio modem operates through a Mobitex network, a radio network for data communication. The network consists, mainly, of exchanges, radio base stations, fixed terminals and mobile terminals.

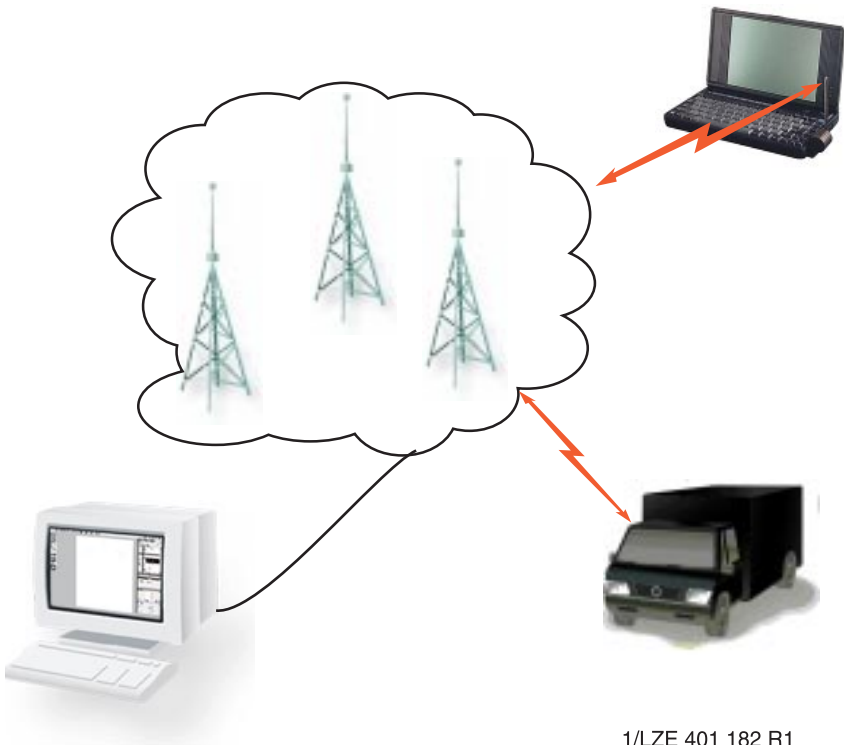

Figure 2 Mobitex network with fixed and mobile terminals.

3.1.1 Fixed terminals

A fixed terminal is connected to the network by landline facilities.

3.1.2 Mobile terminals

A mobile terminal communicates with radio base stations via a radio modem.

3.1.3 Radio base stations and Exchanges

Radio base stations direct data to and from the fixed and mobile terminals in their coverage area. If a radio base station receives data addressed to a mobile or a fixed terminal outside its coverage area, the radio base station transfers the data to the exchange to which it is connected. The exchange, in turn, transfers the data to the radio base station that is in contact with the addressed terminal.

3.1.4 MPAKs

Throughout the Mobitex network, data is transmitted and received in the form of data packets, called MPAKs. Each MPAK includes addressee, sender and user data (text and binary data), as well as certain control data.

An MPAK can contain a maximum of 512 bytes of user data.

3.2 The M3090 Radio Modem

3.2.1 General

By running an application program on the host, a user can transmit and receive data to and from the Mobitex network. The M3090 radio modem operates in half duplex mode when communicating with the network, and in full duplex mode when communicating with the host. The following radio frequencies can be used:

Transmitting frequency	896 - 902 MHz
Receiving frequency	935 - 941 MHz

Note! National regulations may restrict the above frequency ranges

3.2.2 Function Blocks

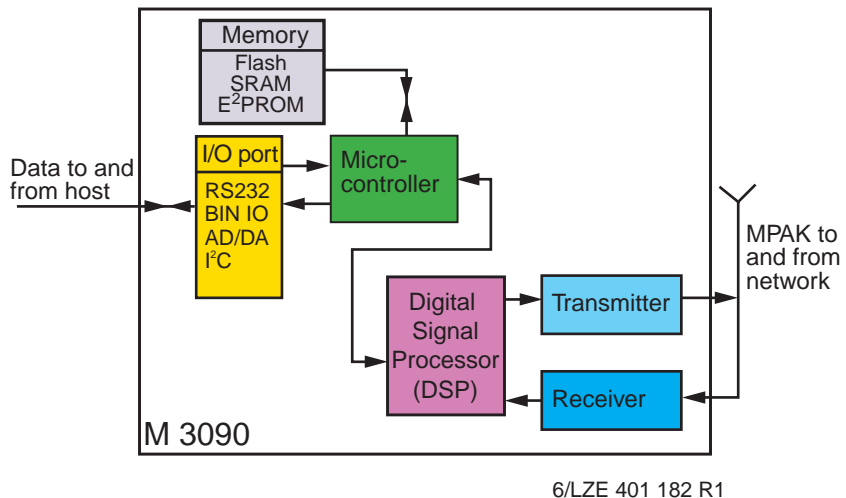

Figure 3 The M3090 radio modem's major function blocks.

Transmitter

The transmitter is turned on when the radio modem:

- is about to become active in the network
- transmits data, i.e. MPAKs, to the radio base station
- acknowledges received MPAKs
- changes radio base stations; it then has to inform the network of the change, this is called Roaming
- changes its operation mode, from power saving mode to express mode or vice versa

Receiver

Besides receiving MPAKs addressed to the host, the radio modem frequently receives control signals from the network. These control signals are used to select the radio base station with the strongest radio signal.

Micro controller

Using the Mobitex Asynchronous Communication Protocol (MASC), the micro controller handles communication between the host and the Mobitex network. The controller consists of a CPU, internal software which handles the MASC protocol, and a radio protocol for communication with the network. For further information about the MASC protocol, see the MASC Programmers Manual.

Memory

The modem software is stored on a flash memory chip while an EEPROM is used for configuration data.

3.2.3 Power

Power is supplied through the system connector. The required voltage is 6-9 V DC (nominally 7.5 V).

Power Operating Modes

When the radio modem is powered, it operates in one of the following three modes:

- sleep
- receiving
- transmitting

Unless communication within the Mobitex network is very intense, the radio modem spends most of its time in the sleep mode. In this mode, the modem waits for host requests and the air interface is inactive. The sleep mode is entered whenever the radio modem is reset or powered on.

The radio modem enters receiving mode when:

- the power saving protocol says it is time to monitor the radio link (power saving mode)
- the host requests that the radio link be constantly monitored (express mode)
- data from the network is expected
- the host requests access to the network

When data needs to be transmitted, the radio modem enters transmitting mode. The time spent in this mode is minimized in order to reduce power consumption.

3.2.4 Antenna

The host equipment must provide an external antenna. The antenna is connected to the radio modem's antenna connector of the SMT type (from M/A Com, see *Chapter 5.2*).

3.3 Host Communication

3.3.1 General

The radio modem communicates with the host equipment through the system connector. A 30 pin MINI-FIX connector (from ODU) is used as a physical interface.

3.3.2 Application Software

The integrator may develop application software (and the MASC/MPAK driver) or use a MASC/MPAK API, which can be bought from Ericsson as a part of the M3090 Integrator's Kit.

3.3.3 Serial Communication

The M3090 radio modem uses serial communication. The modem allows full duplex serial communication with the host through the interface in accordance with the CCITT V.24 standard (where applicable).

The radio modem has functions for handling overrun, parity and framing errors. It also supports all the baud rates used by the MASC protocol.

4 About Antennas

This chapter contains some antenna-technology basics. It is intended to help integrators with little previous experience to select an antenna for the host with which the M3090 radio modem is to be integrated.

If a non-standard antenna has to be designed, please consult an antenna specialist.

4.1 The Functions of an Antenna

An antenna has two functions:

- to emit radio waves (transmission)
- to pick up radio waves (reception).

The antenna does this more or less efficiently, depending on:

- the type of antenna
- the placement of the antenna
- the environment in which the antenna is used.

4.1.1 Half-wave and Quarter-wave Antennas

Two types of antennas are commonly used for mobile radio terminals:

- half-wave antennas
- quarter-wave antennas.

Both are omni-directional antennas, that is, they radiate energy in all directions. However, a half-wave antenna is less sensitive to external influences (movements in its vicinity etc.) than a quarter-wave antenna.

Antenna Lengths

The following lengths are typical for half-wave and quarter-wave antennas in the frequency range that the M3090 radio modem uses. The lengths given will vary for a specific realisation, depending on the material that surrounds the core of the antenna. If in doubt, refer to the documentation included with the antenna.

Frequency range	Half-wave antenna length	Quarter-wave antenna length
890 to 960	appr. 160 mm	appr. 80 mm

Shortened Antennas

A shortened antenna is even shorter than a quarter-wave antenna. It can be designed to have characteristics that are nearly as good as those of a full-length antenna.

4.2 Antenna Concepts

The following sections present some fundamental concepts with regard to antennas.

4.2.1 Antenna Ground Plane

An antenna ground plane is an area under the antenna that is connected to ground and horizontal, flat and sufficiently wide. An antenna with a ground plane will function more efficiently.

It is especially important that quarter-wave antennas have a ground plane.

4.2.2 Polarization

Radio waves radiate parallel to the antenna. The best reception is achieved when the receiving antenna is parallel to the transmitting antenna.

The antennas of Mobitex radio base stations are vertical, which means that the radio waves are vertically polarized.

4.2.3 Antenna Gain

Antenna gain is defined as the ratio between the antenna's radiant intensity and that of a reference antenna which experiences no loss, but has the same power input.

Antenna gain is usually expressed in dBi, the i indicating that the calculated radiation from an isotropic antenna has been used as a reference. The isotropic antenna has the same radiant intensity in all directions, that is, the radiation pattern is spherical.

Note! In data sheets, an antenna's maximum gain is often expressed in dBd without any reference to direction. The (second) d in dBd indicates that the calculated radiation from a single half-wave dipole antenna is used as a reference.

The relationship between dBd and dBi is described in *Figure 4*.

$$\begin{aligned}dBd &= dBi + 2.15 \text{ dB} \\ P(d) &= P(i) \times 1.64\end{aligned}$$

Figure 4 Relationship between dBi and dBd

4.2.4 Environmental Influences

The antenna must have sufficiently effective radiation for the radio terminal to be able to communicate with a radio base station. The maximum range might be up to 15 or 20 kilometres depending on:

- what frequency range the Mobitex network uses (the higher the frequency, the shorter the maximum distance);
- whether the terminal is situated in a built-up area or in open country.

In an urban area, attenuation caused by buildings, walls and other obstacles has to be considered. Too large or too many obstacles around the antenna might mean that the radio terminal cannot establish a contact with the radio base station. In such a case, the antenna is said to be in a radio shadow.

4.3 The M3090 Antenna

An antenna cable is required to connect an antenna to the M3090 modem's antenna connector, that is, a detached antenna is used. A detached antenna should consist of three parts: the antenna rod, an impedance matching network and a coaxial cable with a connector. A detached antenna may be more effective than other types, especially when the radio terminal is used in a vehicle.

4.3.1 Antenna Rod

A half-wave dipole antenna should preferably be used. It should be low-weight and as short as possible, while still complying with the antenna specifications. Antenna specifications are found in *chapter 5 "Technical Data"*.

4.3.2 Antenna Cable

A cable with connectors at each end is required to connect a detached antenna to the radio modem. Use a low-loss cable with high-quality connectors to avoid loss of signal power between the antenna and the modem. Both the cable and the connectors must have an impedance equal to that of the antenna connector of the radio modem, that is, 50 Ω. The antenna cable should be flexible to allow easy fitting of the antenna in a vertical position.

Poor contact between, or mismatching of, the connectors may cause a partial reflection of the signal from the radio modem. The ratio between the modem's output power and the power reflected from the antenna is defined as the Voltage to Standing Wave Ratio (VSWR) and is calculated using the formula shown in *Figure 5*.

$$VSWR = \frac{1 + \sqrt{\frac{\text{ReflectedPower}}{\text{OutputPower}}}}{1 - \sqrt{\frac{\text{ReflectedPower}}{\text{OutputPower}}}}$$

Figure 5 The formula for calculating VSWR.

To get an effective communication, a VSWR of 2 or less is recommended for the antenna, see *chapter 5 "Technical Data"*.

4.4 Antenna Suppliers

The following two antennas, one for portable and one for mobile applications, perform well and have been used during certification to verify SAR limit and FCC RF exposure compliance:

Application:	Portable antenna (portable applications)
Model:	SMA900
Supplier:	Carant Antenn AB, PO Box 4064, S-182 04 Enebyberg, Sweden Tel: +46 8-792-92-00, Fax: +46 8 792 06 77, E-mail: market.dept@carant.se http://www.carant.se
Comment:	Omni-directional whip antenna, SMA male contact Ericsson Product No. KRE 101 1132 (see Figure 6 below)

This portable antenna can only be used in products that can maintain a separation distance of **5 cm** or more between antenna and persons, such as handheld or desk top devices that operate at 5 cm or more from a person's body.

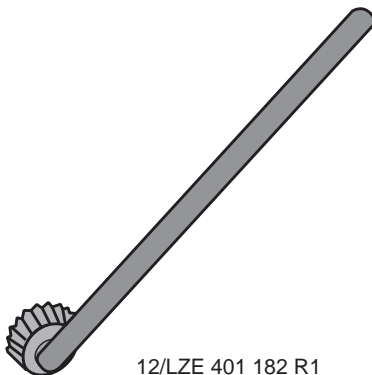

Figure 6 The SMA900 antenna from Carant

Application: Car antenna (intended for 'mobile' applications)
Model: SN8962N
Supplier: Cushcraft Corporation,
48 Perimeter Rd., Manchester N.H., 03103, U.S.A.
Tel: +1 603-627-7877, E-mail: sales@cushcraft.com
<http://www.cushcraft.com/>
Comment: Omni-directional wire,
standard RG58 cable, N connector (male)

A 'mobile' (vehicle-mount) antenna should be *installed* with a separation distance of **20 cm** or more from persons to satisfy mobile operating requirements. This specific Cushcraft antenna must not *operate* at closer than **5 cm** from persons to ensure compliance with applicable SAR limits.

Note! OEM integrators are required to include the appropriate operating requirements in manuals provided to the end user together with the final product to ensure RF exposure compliance. .

Other antennas with substantially equivalent performance characteristics, physical construction and dimensions may also be acceptable. The integrator can use an antenna supplied by a third party or design one that complies with the antenna specifications in *chapter 5 "Technical Data"*.

Antenna and operating configurations other than the original recommended configurations may require separate approval for the applicable national RF exposure compliance.

The given mounting distances and handling provisions for portable antennas (5 cm) and mobile antennas (20 cm) are derived from the present FCC regulations and apply as minimum requirements unless SAR/RF exposure compliance for a specific configuration can be shown at closer distances.

Note! The OEM integrator should verify that applicable emissions standards are complied with for his specific application, especially if others than above reference antennas are used!

5 Technical Data

5.1 Physical Data

Weight 41 g (approx. 1.5oz.)

Main dimensions See *Figure 7*

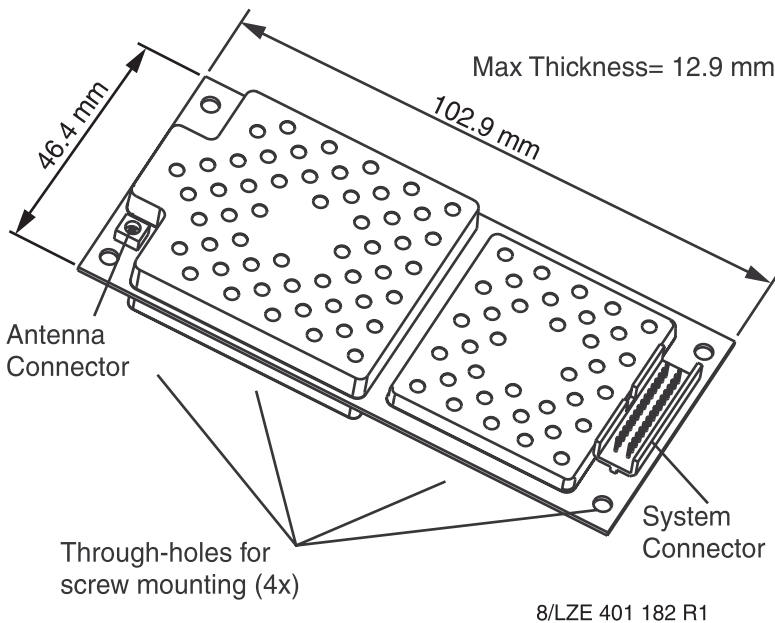
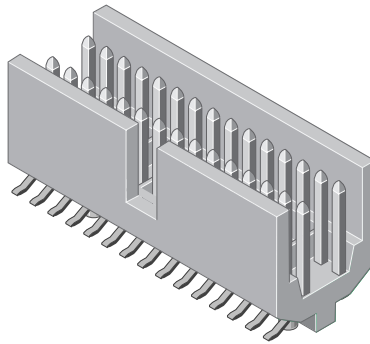

Figure 7 Main dimensions for the M3090 radio modem.

5.2 Connectors and Logical Interfaces

Antenna connector	SMT socket (50Ω) Supplier: M/A Com, http://www.macom.com , Product No. 2367 - 5002 - 54
System connector	30-pin MINI-FIX connector. For pin configuration, see <i>Chapter 5.2.1</i> and <i>Figure 9</i> below. Supplier: ODU, http://www.odu.de , Product No. 515.568.035.030.050
Mating connectors - System connector	
Board-board	ODU, Product No. 525.041.035.030.xxx
Board-cable	
- Socket	ODU, Product No. 525.060.035.030.xxx
- Locking clip	ODU, Product No. 515.067.730.700.000

5.2.1 System Connector - Pin configuration



10/LZE 401 182 R1

Figure 8 The radio modem's system connector.

Pin No.	Symbol	Description
1	Supply voltage	Incoming feed (6-9 V)
2	Supply voltage	Incoming feed (6-9 V)
3	Test	Leave unconnected
4	Reset	Reset (input; active low)
5	Spare	Reserved
6	RD	Serial data from modem
7	TD	Serial data to modem
8	RTS	Request To Send (input), must be terminated
9	CTS	Clear To Send (output)
10	DTR	Data Terminal Ready (input)
11	DCD	Data Carrier Detect (output)
12	REF_CLK	19.2 MHz Reference Clock (output)
13	GND	Ground

Pin No.	Symbol	Description
14	GND	Ground
15	Spare	Reserved
16	Spare	Reserved
17	SCL	I ² C Clock
18	SDA	I ² C Data
19	V _{DD}	Logical reference +3.3 V
20	BIN1_IN	Binary1 IN
21	BIN2_IN	Binary2 IN
22	BIN3_OUT	Binary3 OUT
23	BIN4_OUT	Binary4 OUT
24	WAKE/Systemstart	Switch main regulator ON (input; active low)
25	GND	Ground
26	DOWNLOAD	Download
27	AD_OUT	User analog OUT
28	GND	Ground
29	GND	Ground
30	AD_IN	User analog IN

5.2.2 System Connector - Pin orientation

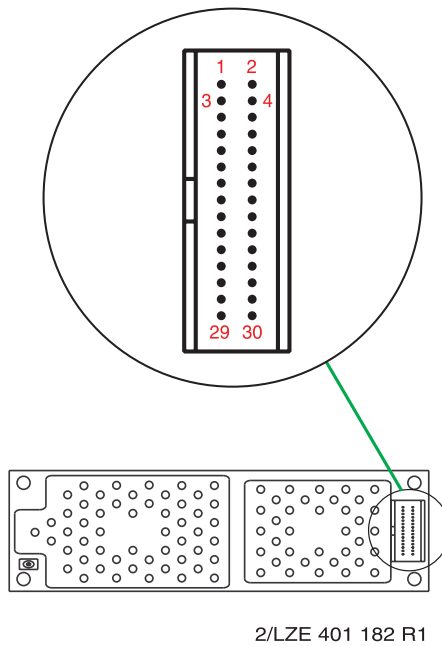

Figure 9 System connector - pin orientation

- Hints:**
1. The DSR signal is not available at the M3090 serial interface. Certain older Mobitex applications require the signal to be set by the modem. Workaround: connect DTR and DSR on the host system side for compatibility with these old Mobitex applications.
 2. Signal RTS (pin 8 of the system contact (input)) must always be terminated. If RTS is not used in a specific application, connect it to ground (for example pin 14).

5.3 Power Supply

Operating voltage	6 - 9 V (7.2 V nominal)
Current consumption	See <i>Chapter 5.3.1</i> below
Maximum ripple	See <i>Chapter 5.3.2</i> below
DC characteristics, System Connector	See <i>Chapter</i> below

5.3.1 Current consumption

Total current

Operational mode	Description	Current consumption
Sleep mode	The radio modem's logic part is on and the radio part is off.	85 mA
Receiving mode	The modem is on and receiving data or control signals from the Mobitex network.	<200 mA
Transmitting mode	The modem is on and transmitting data to the Mobitex network	1150 mA (2 A peak)

5.3.2 Maximum ripple

Ripple on power supply voltage at system connector, maximum values:DC

Frequency	V _{DD} pin
< 100 Hz	150 mV _{RMS}
100 Hz to 10 kHz	100 mV _{RMS}
10 to 440 kHz	50 mV _{RMS}
440 to 460 kHz	5 mV _{RMS}
460 kHz to 94 MHz	50 mV _{RMS}
94 to 96 MHz	1 mV _{RMS}
96 to 850 MHz	50 mV _{RMS}
850 to 950 MHz	1 mV _{RMS}

5.3.3 Characteristics for the System Connector

Symbol	Parameter	Min	Max	Unit	Notes
V _{IL}	Input Voltage, Low	0	0.8	V	
V _{IH}	Input Voltage, High	2.0	V _{DD}	V	
V _{OL}	Output Voltage, Low	0	0.5	V	Valid if I _{OL} < 1mA
V _{OH}	Output Voltage, High	2.7	V _{DD}	V	Valid if I _{OH} < 1mA
C _{IN}	Input Capacitance		100	pF	

$$V_{DD} = 3.3 \text{ V}$$

5.4 Environmental Specifications

The M3090 radio modem has been tested in accordance with the IEC 60068, IEC 61000 and ISO 7816 standards.

The environmental tests are divided into four groups:

- Transport/storage
- Climatic
- Mechanical
- Electrical

The modem satisfies the requirements specified under each group below.

5.4.1 Transport/storage

Tested unit: Radio modem in delivery package, non-operating ($V_{DD}=0$).

Temperature range	-40 to +70° C
Relative humidity	5-95%
X-ray exposure	Dose: 0.1 Gy
Free fall	1 m drop to concrete surface

5.4.2 Climatic

Tested unit: Radio modem, operating

Temperature range	-25 to +65° C
Relative humidity	5-95%

5.4.3 Mechanical

Tested unit: Radio modem, non-operating (supply voltage=0) unless otherwise stated below.

Random vibration	(operating)	10-195 Hz 195-205 Hz 205-500 Hz (60 min/axis)	0.03 g ² /Hz 0.03 → 0.01 g ² /Hz 0.01 g ² /Hz
Sinus vibration, endurance		10-500 Hz, 1 octave/min, acceleration 15 g, amplitude ≤ 1 mm (10 cycles/axis)	
Sinus vibration, radio resonance investigation	(operating)	10-150 Hz 150-500 Hz 500-2000 Hz 1 octave/ 5 min (1 cycle/axis)	20 m/s ² 10 m/s ² 5 m/s ²
Shock		Peak acceleration 100 g, pulse duration 6 ms (half-sine) (6 shocks/axis)	
Bump	(operating)	Peak acceleration 15 g, pulse duration 6 ms (half-sine) (1000 bumps/axis)	
Free fall		1 m drop to steel surface (2 falls on each face)	

5.4.4 Electrical

Tested unit: Radio modem, operating

Electrostatic discharge	contact 4.0 kV air 8.0 kV (antenna)
Immunity, radiated electromagnetic field	Severity 10 V/m
Ripple	See "Maximum ripple" on page 25

5.5 Safety Specifications

Components and materials comply with the EN60950 standard (European Standards – CENELEC – Safety of Information Technology Equipment, including electrical business equipment).

5.6 Radio Specifications

Transmitter frequencies	896.0 to 902.0 MHz ¹
Receiver frequencies	935.0 to 941.0 MHz ¹
Data transfer rate	8 kbps (gross rate)
Channel separation	12.5 kHz
Channel selection	automatic roaming
Frequency stability	1.5 ppm (\approx 1.35 kHz)
Receiver sensitivity	-115 dBm
Modulation	modified GMSK
Transmitter output	2 W maximum; Power attenuation in 3 dB steps, down to -21 dB relative to maximum output.

¹ National regulations may restrict this frequency range.

5.7 External Antenna Specifications

Antenna impedance (nominal)	50 Ω
Frequency range	890 - 960 MHz
Recommended antenna gain	2 dBi
Voltage to Standing Wave Ratio (VSWR)	max. 2
Recommended antenna length	approx. 160 mm (half-wave)
Polarization	vertical
Half-power beam-width,	
horizontal	80°
vertical	360°
Recommended cable length	0.75 m
Connector type (on radio modem)	SMT (from M/A Com), see <i>Figure 10</i>
Humidity	max. 95% RH

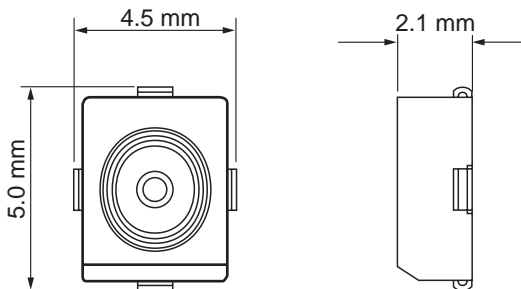

7/LZE 401 182 R1

Figure 10 The radio modem's SMT antenna connector

6 Host Requirements

This chapter presents the requirements, technical and environmental, that have to be considered when integrating M3090 radio modems with host equipment.

6.1 Host Environment

The host must provide a physical environment where the radio modem is not exposed to temperatures, humidity etc. beyond what it is designed for.

Refer to *chapter 5 “Technical Data”* for detailed requirements regarding:

- Physical Data
- Connectors and Logical Interfaces
- Power Supply
- Environmental Specifications

6.2 Integrator's Kit

To facilitate the integration of the M3090 radio modem, Ericsson supplies an Integrator's Kit (Product No. KRY 901 46). The kit contains:

- The MobiOne configuration software (Windows 95/NT compatible) for the setting of a Mobitex Access Number, country code(s) etc. before the modem is used in a Mobitex network.
- MASC-Driver, with source code.
- IP-Gateway/MASC Demo "Hello World".
- 1 Interface Converter, 3.3V-CMOS / V.28, ROA 117 9629.
- 1 Antenna.
- Integration directives.

6.3 Physical installation of the Radio Modem

Place the radio modem so that it is protected from pollution, vibrations and shock. Avoid placing the modem close to any circuit that is likely to cause interference. Secure the modem correctly to prevent it from falling out when transporting or moving the host equipment.

The antenna should preferably be fitted so that it is always vertical, regardless of the host equipment's position.

Make sure that the radio modem's antenna and system connectors can be accessed when the modem is fixed in the host equipment.

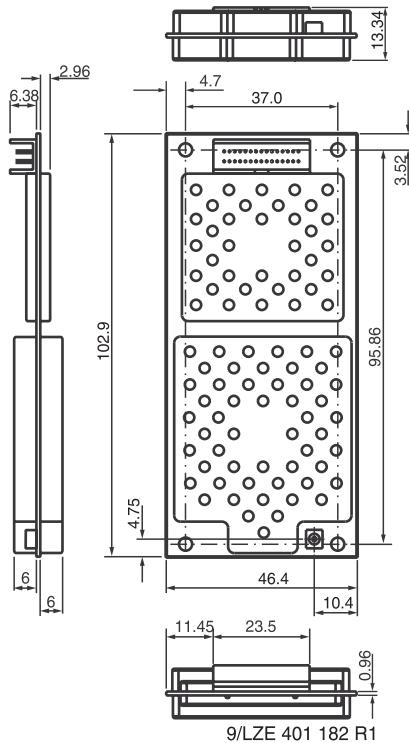

Figure 11 Dimensions of the M3090 radio modem.

6.3.1 5 V to 3.3 V Conversion

If the host equipment uses 5 V logic, the electrical interface needs to be converted to 3.3 V. *Figure 12* below shows an example of how to implement such a conversion.

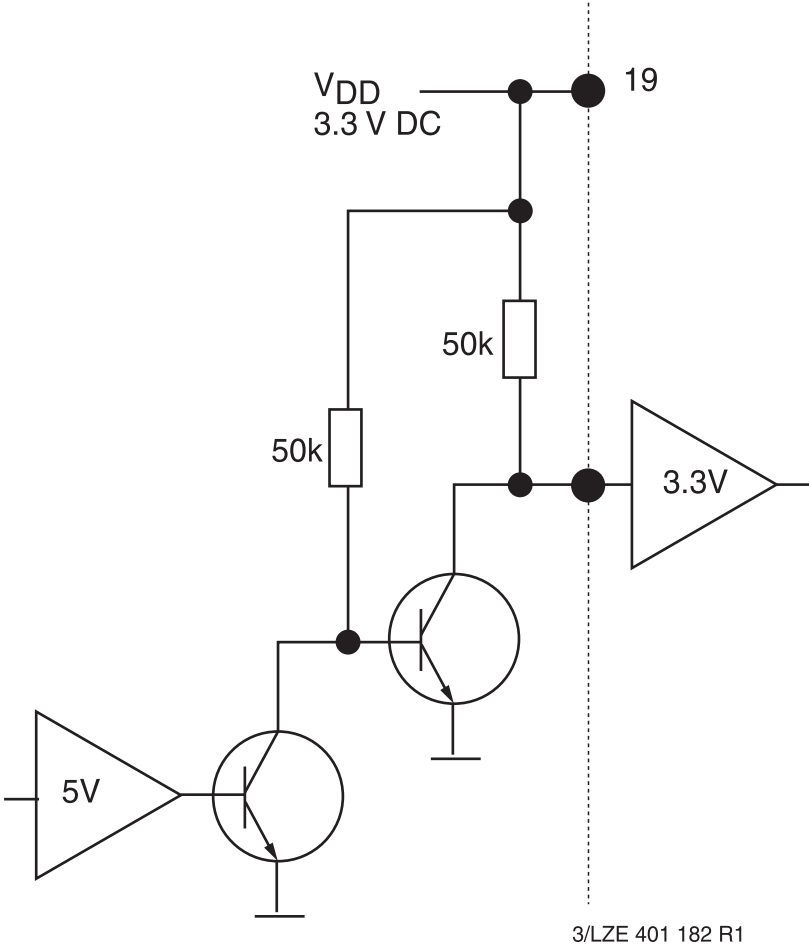
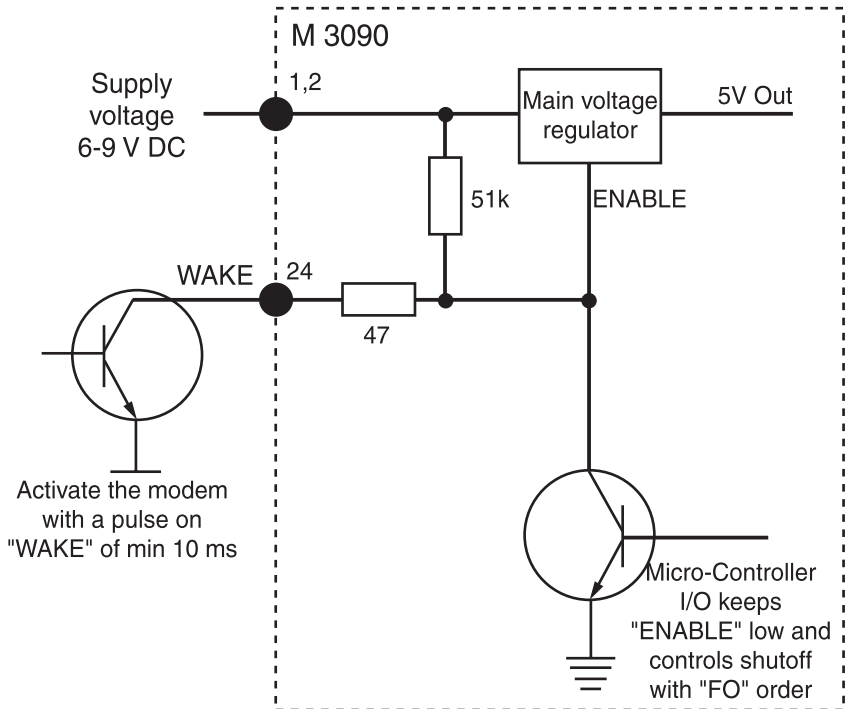

Figure 12 5 V to 3.3 V Conversion

6.3.2 ON/OFF function

An ON/OFF function can be implemented using standard MASC-commands, see *Figure 13*.



4/LZE 401 182 R1

Figure 13 Example of how to implement an ON/OFF function.

Start the modem by grounding pin 24 for a minimum of 10 ms ("WAKE" – pin 24 – is active low).

Shut the modem off using the "FO" MASC-command. When "FO" is sent, "WAKE" must be high. *Figure 13* shows an example of how to implement this using an Open Collector Connection. A relay or a switch can also be used.

6.3.3 Cooling

Normally, no special measures are needed to cool M3090 radio modems. However, if ambient temperature exceeds +65° C (see *Chapter 5.4.2.*), cooling will be required, otherwise the modem may over-heat and lose contact with the network.

The heat dissipation of an M3090 radio modem varies depending on the volume of data being transmitted. In normal use, when the modem transmits less than 1% of the time, the power consumption is less than 300 mW.

6.3.4 Grounding

The M3090 radio modem card does not need to be grounded beyond what is provided through the system connector.

However, it is recommended that the antenna connector be grounded, by grounding the fixing screws. This will:

- improve the gain of the antenna;
- make the radio modem less sensitive to electrostatic discharge (ESD).

6.3.5 ESD Protection

M3090 radio modems are sensitive to electrostatic discharge. Use normal precautions to prevent ESD.

6.3.6 Shielding

M3090 radio modems fulfil the shielding requirements set by the regulatory approval authorities in the USA and Canada. Therefore, additional shielding of the modem is normally not necessary.

6.4 Selecting an Antenna

The antenna must be designed for the frequency range used by the radio modem. The antenna must have the same impedance as the card's antenna connector, otherwise the transmitter's output power will be reduced. For information on radio frequencies and connector data, see *chapter 5 "Technical Data"*.

Perform the tests described – under Integration Tests – in the Integrator's Kit to find out whether the selected antenna suits the host in question. If tests show that the antenna cannot be used, it might be helpful to read *chapter 4 "About Antennas"*.

If a non-standard antenna has to be designed, consult an antenna specialist to make sure that all requirements are fulfilled.

6.5 Connecting the Antenna

6.5.1 General

The M3090 radio modem must be equipped with an antenna that connects to the modem via an antenna cable.

If possible, mount the antenna so that it is vertical at all times.

6.5.2 External Antenna Test

An external antenna must comply with the specifications in *chapter 5 "Technical Data"*. Compliance should be verified by performing the tests described in the Integrator's Kit.

6.6 Connecting the Radio Modem to the Host

Taking customary precautions against ESD, proceed as follows:

1. Mechanically fix the radio modem to the host.
2. Connect the antenna cable to the modem's antenna connector. If a separate antenna cable is used, make sure that the antenna rod is also connected.

Note! Operating the modem without an antenna may cause severe damage.

3. Connect the male system connector plug to the socket on the modem.

7 Type Approval

Any two-way communication radio, such as the M3090 radio modem, must be type-approved by the appropriate authorities before it can be sold and used in a country. Most countries have their own national bodies for type approvals, but a number of European Community member countries share a common authority.

These authorities grant type approvals to radios that have been successfully tested by a certified radio test laboratory. The tests performed show if the radio complies with the standards specified by the type approval authorities.

7.1 Requirements in the USA

7.1.1 Compliance and Type Approval Number

The M3090 radio modem complies with applicable radio standards in the USA.

Do not modify the M3090 modem, or connect to it any component or product that is not compatible with the M3090 interface as specified in this manual. Ericsson does not warrant any defects, non-conformities and/or deviations caused by such actions.

The modem has been issued with a type approval number, which can be retrieved at:

Federal Communications

Commission (FCC)

1919 M Street NW

Washington D.C. 20554

<http://www.fcc.gov/>

7.1.2 Verification and Labelling

Compliance with applicable standards must be verified by the manufacturer of the host equipment and stated on the integrated product. The type approval information for the radio modem must also be stated.

The Modem

The radio modem is delivered with the required type approval information shown on a label applied to it, see *Figure 14*.

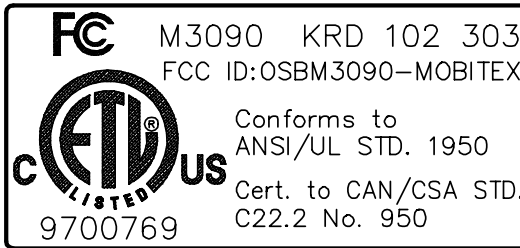

Figure 14 Label applied to the radio modem.

The Modem Delivery Package

The radio modem is delivered in a package marked as shown in *Figure 15*.

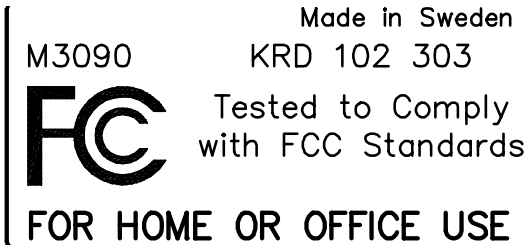
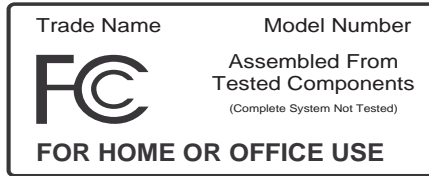

Figure 15 Label for the modem delivery package.

The Product

The integrated product should have a label in the format shown in *Figure 16*.



14/LZE 401 182 R1

Figure 16 Specimen label for the integrated product

In addition to the above label, the assembled product should have a sticker with a text that identifies the built-in radio device, such as :

“This device contains radio equipment with
FCC ID OSBM3090-MOBITEX”

Index

A

- antenna 13
 - cable 16
 - connecting 37
 - connector 20
 - connector type 30
 - functions 13
 - gain 15
 - ground plane 14
 - impedance 30
 - length 14
 - polarization 14
 - rod 16
 - selecting 37
 - suppliers 17
- application software 12

B

- base station 8
- beam-width, half-power 30

C

- channel
 - selection 29
 - separation 29
- connecting modem to host 38
- connectors and logical interfaces 20
- cooling 36
- current consumption 23

D

data transfer rate 29
DC characteristics, system connector 25

E

electrical interface, conversion from 5 V 34
electromagnetic field, immunity 28
electrostatic discharge 28
environmental specifications 26

- electromagnetic field, immunity 28
- electrostatic discharge 28
- free fall 26, 27
- relative humidity 26
- shock 27
- temperature range 26
- vibration 27
- X-ray exposure 26

Ericsson

- to contact 4

ESD protection 36
exchange 8
explosive environment 1

F

fixed terminal 8
free fall 26, 27
frequencies, transmitter/receiver 29
frequency stability 29
fuse 1

G

gain, antenna 15
ground plane, antenna 14
grounding 36

H

half-power beam-width 30
host
 communication 12
 definition 5
 Requirements 31

I

integrator, definition 5

M

medical life support equipment, use with 1
micro controller 10
mobile terminal 8
Mobitex network 7
modulation 29
MPAK 8

O

ON/OFF function 35
operating voltage 23

P

personal medical electronic devices, use with 1
physical data 19
physical installation 33
pin configuration, system connector 21
pin orientation, system connector 22
polarization, antenna 14
power
 operating modes 11

- power supply 23
 - current consumption 23
 - maximum ripple 24
 - operating voltage 23
- precautions 1
- product care 2

Q

- questions and comments 4

R

- radio base station 8
- radio specifications 29
- range, maximum 15
- receiver 10
 - frequencies 29
 - sensitivity 29
- relative humidity 26
- ripple, maximum 24

S

- safety advice 1
- safety specifications 28
- shielding 36
- shock 27
- system connector 20

T

- technical data 19
- temperature range 26
- terminal, definition 5
- terminology 5
- transfer rate, data 29

transmitter 10
 frequencies 29
 output 29
type approval 39
 labelling 40

V

vibration 27
Voltage to Standing Wave Ratio 16, 30
voltage, operating 23
VSWR 30
 calculating 16

X

x-ray exposure 26

Ericsson Mobile Data Design AB

Technical Assistance Centre

S:t Sigfridsgatan 89

S-412 66 Göteborg, SWEDEN

Fax: +46 31 703 6033

E-mail: mobitex.tac@erv.ericsson.se

198 17 - KRD 102 303 Uen, Rev B