



# FCC TEST REPORT

According to

## FCC Rules and Regulations Part 15 Subpart C

Applicant	: Zhuhai FTZ Oplink Communications, Inc.
Address	: #29, #30 Lianfeng Avenue, Free Trade Zone, Zhuhai City, Guangdong Province, 519030 China
Equipment	: MJPEG Wireless IP Camera with Night Vision
Model No.	: IPC1200
FCC ID	: OS3IPC01
Trade Name	: OPLINK

- The test result refers exclusively to the test presented test model / sample.,
- Without written approval of **CerpPASS Technology Corp.**, the test report shall not be reproduced except in full.
- The EUT is also considered as a kind of computer peripheral, because the connection to computer is necessary for typical use. It has been verified to comply with the requirements of FCC Part 15, Subpart B, Class B (DoC). The test report has been issued separately.



## Contents

<b>1. Report of Measurements and Examinations</b>	<b>6</b>
1.1 List of Measurements and Examinations	6
<b>2. Test Configuration of Equipment under Test</b>	<b>7</b>
2.1 Feature of Equipment under Test	7
2.2 Carrier Frequency of Channels	8
2.3 Test Mode and Test Software	9
2.4 Description of Test System	9
2.5 General Information of Test	10
2.6 Measurement Uncertainty	10
<b>3. Antenna Requirements</b>	<b>11</b>
3.1 Standard Applicable	11
3.2 Antenna Construction and Directional Gain	11
<b>4. Test of Conducted Emission</b>	<b>12</b>
4.1 Test Limit	12
4.2 Test Procedures	12
4.3 Typical Test Setup	13
4.4 Measurement Equipment	13
4.5 Test Result and Data	14
4.6 Test Photographs	32
<b>5. Test of Radiated Emission</b>	<b>33</b>
5.1 Test Limit	33
5.2 Test Procedures	33
5.3 Typical Test Setup	34
5.4 Measurement Equipment	34
5.5 Test Result and Data (9kHz ~ 30MHz)	35
5.6 Test Result and Data	35
5.7 Test Photographs (30MHz~1000MHz)	143
5.8 Test Photographs (1000MHz~25000MHz)	144
<b>6. 6dB Bandwidth Measurement Data</b>	<b>145</b>
6.1 Test Limit	145
6.2 Test Procedures	145
6.3 Test Setup Layout	145
6.4 Measurement Equipment	145
6.5 Test Result and Data	145
<b>7. Maximum Peak and Average Output Power</b>	<b>152</b>
7.1 Test Limit	152
7.2 Test Procedures	152
7.3 Test Setup Layout	152
7.4 Measurement Equipment	152
7.5 Test Result and Data	153
<b>8. Power Spectral Density</b>	<b>166</b>
8.1 Test Limit	166
8.2 Test Procedures	166



8.3 Test Setup Layout ..... 166

8.4 Measurement Equipment..... 166

8.5 Test Result and Data..... 166

**9. Band Edges Measurement ..... 173**

9.1 Test Limit ..... 173

9.2 Test Procedure ..... 173

9.3 Test Setup Layout ..... 173

9.4 Measurement Equipment..... 173

9.5 Test Result and Data..... 173

9.6 Restrict Band Emission Measurement Data ..... 182

**10. Restricted Bands of Operation ..... 188**

10.1 Labeling Requirement..... 188

**Appendix A. Photographs of EUT.....A1 ~ A10**





# CERTIFICATE OF COMPLIANCE

According to

## FCC Rules and Regulations

### Part 15 Subpart C

Applicant : Zhuhai FTZ Oplink Communications, Inc.  
Address : #29, #30 Lianfeng Avenue, Free Trade Zone,  
Zhuhai City, Guangdong Province, 519030 China  
Equipment : MJPEG Wireless IP Camera with Night Vision  
Model No. : IPC1200  
FCC ID : OS3IPC01

I **HEREBY** CERTIFY THAT :

The measurements shown in this test report were made in accordance with the procedures given in **ANSI C63.4 2009, KDB558074 & KDB662911**. The equipment was **passed** the test performed according to **FCC Rules and Regulations Part 15 Subpart C (2010)**. The test was carried out on Jul. 02, 2012 at CerpPASS Technology Corp.

Approved by:

Tested by:

  
Hill Chen  
EMC/RF B.U. Assistant Manager

  
Ben Lu  
Engineer



# 1. Report of Measurements and Examinations

## 1.1 List of Measurements and Examinations

FCC Rule	Description of Test	Result
15.203	. Antenna Requirement	Pass
15.207	. Conducted Emission	Pass
15.209 15.247(d)	. Radiated Emission	Pass
15.247(a)(2)	. 6dB Bandwidth	Pass
15.247(b)	. Maximum Peak Output Power	Pass
15.247(d)	. 100kHz Bandwidth of Frequency Band Edges	Pass
15.247(e)	. Power Spectral Density	Pass
1.1307 1.1310 2.1091 2.1093	. RF Exposure Compliance	Pass



## 2. Test Configuration of Equipment under Test

### 2.1 Feature of Equipment under Test

Networking	LAN	10Base-T Ethernet or 100Base-TX Fast Ethernet, Auto-MDIX
	WLAN	IEEE 802.11b/g/n
Accessing the Camera using Web Browser	Platform	Microsoft® Windows® 2000/XP/Vista/Win7
	CPU	Intel Pentium III 800MHz or above
	RAM	512MB
	Resolution	800 x 600 or above
	User Interface	Microsoft® Internet Explorer 6.0 or above; Apple Safari 2 or above; Mozilla Firefox 2.00 or above; Google Chrome
Accessing the Camera using UltraView Pro	Platform	Microsoft® Windows® XP/Vista/Win 7
	Resolution	1024 x 768 or above
Hardware Requirement	1~8 cameras	Intel Core 2 Duo 2GB RAM
	9~32 cameras	Intel Core 2 Quad 4GB RAM
Adapter	AMIGO \ AMS47-0501200FU Input: 100-240V ~ 50-60Hz, 0.2A 15VA Output: 5V / 1.2A	
	JENTEC \ CF0605-B Input: 100-240V ~ 50-60Hz, 0.18A Output: 5V / 1.2A	
	DVE \ DSC-6PFA-05 FUS 050100 Input: 100-240V ~ 50-60Hz, 0.2A Output: 5V / 1.0A	
Antenna Gain	3.9dBi	
Modulation Type & Rate	802.11b: 11Mbps 802.11g: 54Mbps 802.11n HT20: 65Mbps 802.11n HT40: 135Mbps	



## 2.2 Carrier Frequency of Channels

802.11b, 802.11g, 802.11n HT 20

Channel	Frequency(MHz)	Channel	Frequency(MHz)
01	2412	07	2442
02	2417	08	2447
03	2422	09	2452
04	2427	10	2457
05	2432	11	2462
06	2437	---	---

802.11n, HT40

Channel	Frequency(MHz)	Channel	Frequency(MHz)
---	---	08	2447
---	---	09	2452
03	2422	---	---
04	2427	---	---
05	2432	---	---
06	2437	---	---
07	2442	---	---





### 2.3 Test Mode and Test Software

- a. During testing, the interface cables and equipment positions were varied according to ANSI C63.4.
  - b. The complete test system included Notebook and EUT for the test.
  - c. An executive program, "MP TEST" under WIN XP was executed to transmit and receive data to the remote workstation through WLAN.
  - d. The following test modes were performed for test:
    - 802.11b/g/n HT20: CH01: 2412MHz, CH06: 2437MHz, CH11: 2462MHz
    - 802.11n HT40: CH03: 2422MHz, CH06: 2437MHz, CH09: 2452MHz
- \*Adapter: AMIGO \ AMS47-0501200FU, JENTEC \ CF0605-B, DVE \ DSC-6PFA-05 FUS 050100  
 \* Power output of data rate:

802.11b		802.11g		802.11n HT20		802.11n HT40	
Data Rate (Mbps)	Power output (dBm)	Data Rate (Mbps)	Power output (dBm)	Data Rate (Mbps)	Power output (dBm)	Data Rate (Mbps)	Power output (dBm)
11	18.15	54	14.09	130/15	13.37	270/15	13.32
5.5	18.12	48	14.07	117/14	13.34	243/14	13.30
2	18.13	36	14.05	104/13	13.32	216/13	13.29
1	18.11	24	14.02	78/12	13.34	162/12	13.27
---	---	18	14.06	52/11	13.32	108/11	13.26
---	---	12	14.03	39/10	13.32	81/10	13.23
---	---	9	14.07	26/9	13.33	54/9	13.28
---	---	6	14.05	13/8	13.31	27/8	13.25
---	---	---	---	65/7	13.35	135/7	13.23
---	---	---	---	58.5/6	13.33	121.5/6	13.25
---	---	---	---	52/5	13.31	108/5	13.26
---	---	---	---	39/4	13.32	81/4	13.27
---	---	---	---	26/3	13.31	54/3	13.26
---	---	---	---	19.5/2	13.32	40.5/2	13.28
---	---	---	---	13/1	13.35	27/1	13.29
---	---	---	---	6.5/0	13.36	13.5/0	13.30

### 2.4 Description of Test System

Device	Manufacturer	Model No.	Description
Notebook	DELL	INSPIRON 510m	Power Cable, Unshielding 1.8m



## 2.5 General Information of Test

Test Site :	CerpPASS Technology Corp. 2F-11, No. 3, Yuan Qu St., (Nankang Software Park), Taipei, Taiwan 115, R.O.C.
Test Site Location (OATS2-SD) :	No.68-1, Shihbachongsi, Shihding Township, Taipei City 223, Taiwan, R.O.C.
FCC Registration Number:	TW1049, TW1061, 488071, 390316
IC Registration Number :	4934B-1, 4934D-1
VCCI Registration Number:	T-1173 for Telecommunication Test C-4139 for Conducted emission test R-3428 for Radiated emission test G-97 for radiated disturbance above 1GHz
Test in Compliance with:	ANSI C63.4-2009 FCC Part 15 Subpart C
Frequency Range Investigated:	Conducted: from 150kHz to 30MHz Radiation: from 30MHz to 25,000MHz
Test Distance:	The test distance of radiated emission from antenna to EUT is 3 M.
Laboratory Accreditation	

## 2.6 Measurement Uncertainty

Measurement Item	Uncertainty
Radiated emission	±4.11dB
Peak Output Power(conducted)	±1.38dB
Peak Output Power(Radiated)	±1.70dB
Power Spectral Density	±1.39dB
Radiated emission(3m)	±4.11dB
Radiated emission(10m)	±3.89dB



### 3. Antenna Requirements

#### 3.1 Standard Applicable

For intentional device, according to FCC 47 CFR Section 15.203, an intentional radiator shall be designed to ensure that no antenna other than that furnished by the responsible party shall be used with the device.

And according to FCC 47 CFR Section 15.247 (b), if transmitting antennas of directional gain greater than 6dBi are used, the power shall be reduced by the amount in dB that the directional gain of the antenna exceeds 6dBi.

#### 3.2 Antenna Construction and Directional Gain

Antenna Type: PCB Antenna

Antenna Gain: 3.9 dBi



## 4. Test of Conducted Emission

### 4.1 Test Limit

Conducted Emissions were measured from 150 kHz to 30 MHz with a bandwidth of 9 KHz on the 120 VAC power and return leads of the EUT according to the methods defined in ANSI C63.4-2009 Section 3.1. The EUT was placed on a nonmetallic stand in a shielded room 0.8 meters above the ground plane as shown in section 2.2. The interface cables and equipment positioning were varied within limits of reasonable applications to determine the position produced maximum conducted emissions.

Frequency (MHz)	Quasi Peak (dB $\mu$ V)	Average (dB $\mu$ V)
0.15 – 0.5	66-56*	56-46*
0.5 – 5.0	56	46
5.0 – 30.0	60	50

\*Decreases with the logarithm of the frequency.

### 4.2 Test Procedures

- The EUT was placed 0.4 meter from the conducting wall of the shielding room was kept at least 80 centimeters from any other grounded conducting surface.
- Connect EUT to the power mains through a line impedance stabilization network (LISN).
- All the support units are connecting to the other LISN.
- The LISN provides 50 ohm coupling impedance for the measuring instrument.
- The FCC states that a 50 ohm, 50 micro-Henry LISN should be used.
- Both sides of AC line were checked for maximum conducted interference.
- The frequency range from 150 kHz to 30 MHz was searched.
- Set the test-receiver system to Peak Detect Function and Specified Bandwidth with Maximum Hold Mode.



### 4.3 Typical Test Setup

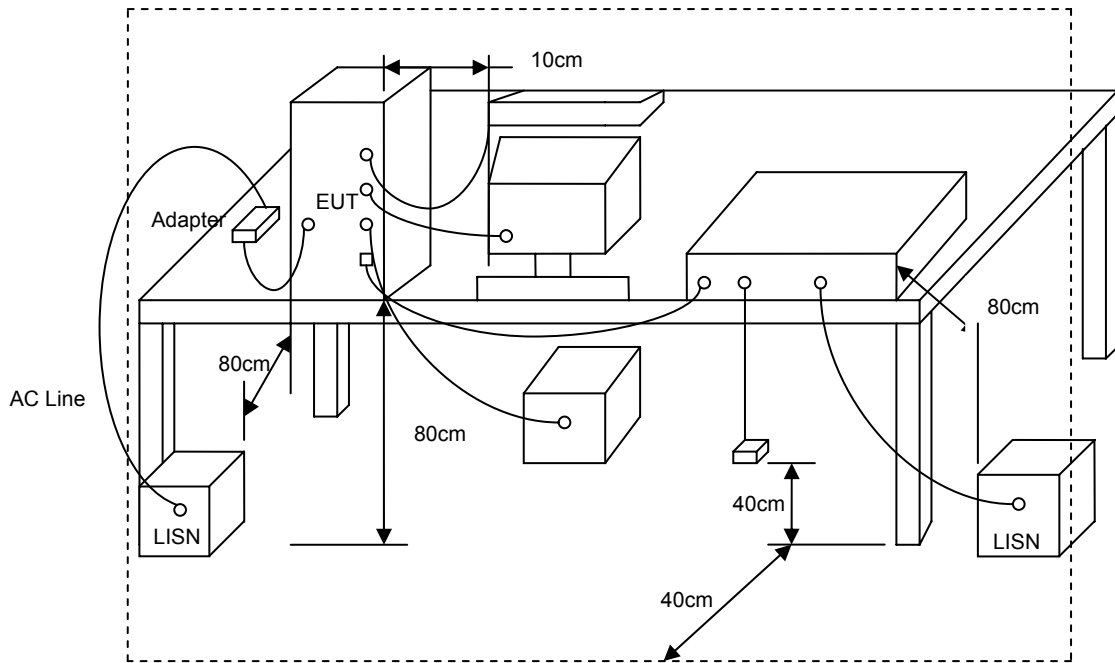

### 4.4 Measurement Equipment

Instrument/ Ancillary	Model No.	Manufacturer	Serial No.	Calibration Date	Valid Date
EMI Receiver	R&S	ESCI	100443	2012/01/12	2013/01/11
LISN	Schwarzbeck	NSLK 8127	8127-516	2012/03/08	2013/03/07
LISN	Schwarzbeck	NSLK 8127	8127-568	2011/08/24	2012/08/23



### 4.5 Test Result and Data

Power	: AC 120V	Pol/Phase	: LINE
Test Mode 1	: 802.11g, CH1	Temperature	: 26 °C
Test Date	: Jul. 05, 2012	Humidity	: 60 %
Memo	: Adapter: DVE \ DSC-6PFA-05 FUS 050100		

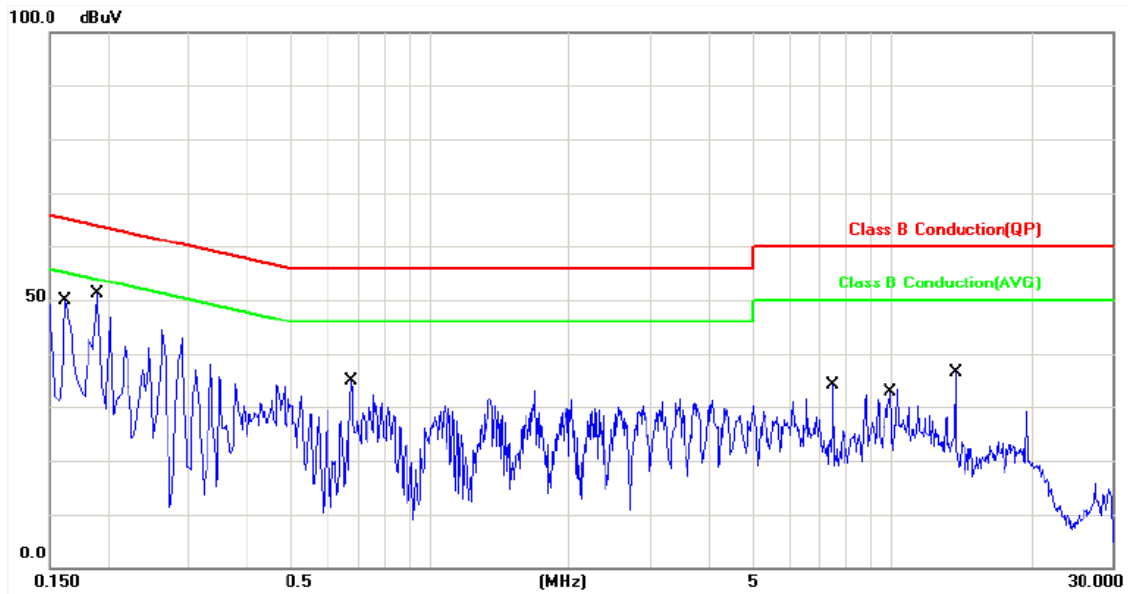

No.	Frequency (MHz)	Factor (dBuV)	Reading (dBuV)	Level (dBuV)	Limit (dBuV)	Margin (dB)	Detector	P/F
1	0.1620	0.12	46.34	46.46	65.36	-18.90	QP	P
2	0.1620	0.12	36.45	36.57	55.36	-18.79	AVG	P
3	0.1900	0.12	46.52	46.64	64.03	-17.39	QP	P
4	0.1900	0.12	36.74	36.86	54.03	-17.17	AVG	P
5	0.6740	0.15	34.83	34.98	56.00	-21.02	QP	P
6	0.6740	0.15	33.49	33.64	46.00	-12.36	AVG	P
7	7.4820	0.48	30.40	30.88	60.00	-29.12	QP	P
8	7.4820	0.48	15.51	15.99	50.00	-34.01	AVG	P
9	9.9140	0.58	18.48	19.06	60.00	-40.94	QP	P
10	9.9140	0.58	9.63	10.21	50.00	-39.79	AVG	P
11	13.7140	0.74	28.34	29.08	60.00	-30.92	QP	P
12	13.7140	0.74	14.36	15.10	50.00	-34.90	AVG	P

Note: Level = Reading + Factor  
Margin = Level – Limit



Power	: AC 120V	Pol/Phase	: NEUTRAL
Test Mode 1	: 802.11g, CH1	Temperature	: 26 °C
Test Date	: Jul. 05, 2012	Humidity	: 60 %
Memo	: Adapter: DVE \ DSC-6PFA-05 FUS 050100		

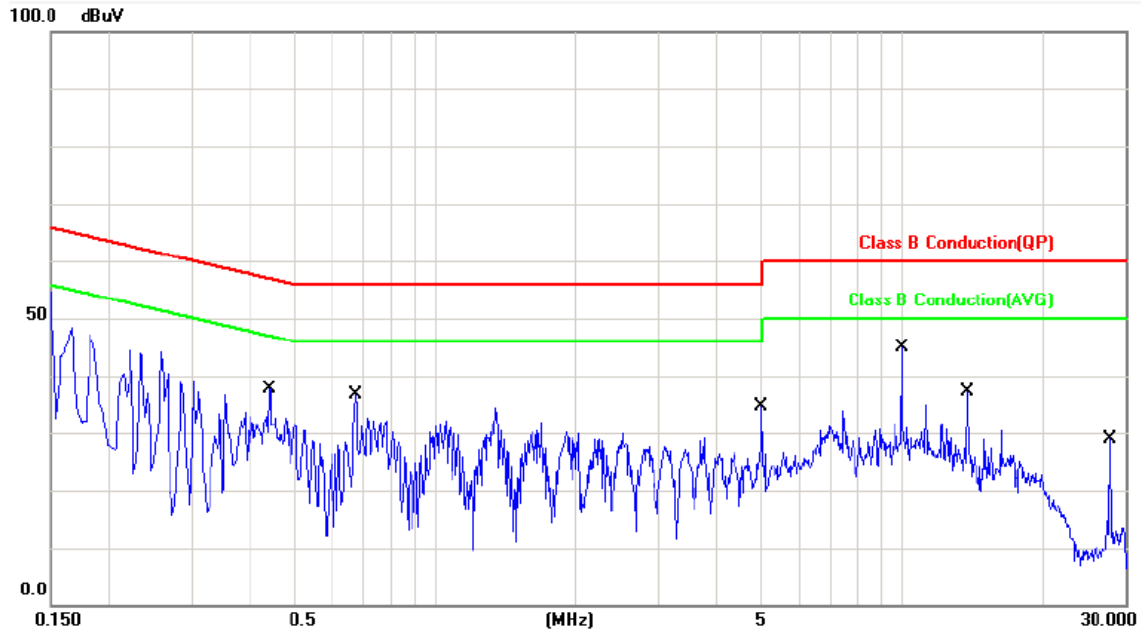

No.	Frequency (MHz)	Factor (dBuV)	Reading (dBuV)	Level (dBuV)	Limit (dBuV)	Margin (dB)	Detector	P/F
1	0.4420	0.13	32.33	32.46	57.02	-24.56	QP	P
2	0.4420	0.13	22.47	22.60	47.02	-24.42	AVG	P
3	0.6740	0.15	36.85	37.00	56.00	-19.00	QP	P
4	0.6740	0.15	33.65	33.80	46.00	-12.20	AVG	P
5	5.0020	0.39	28.42	28.81	60.00	-31.19	QP	P
6	5.0020	0.39	23.39	23.78	50.00	-26.22	AVG	P
7	10.0020	0.58	40.76	41.34	60.00	-18.66	QP	P
8	10.0020	0.58	28.35	28.93	50.00	-21.07	AVG	P
9	13.7540	0.74	22.81	23.55	60.00	-36.45	QP	P
10	13.7540	0.74	19.79	20.53	50.00	-29.47	AVG	P
11	27.9580	1.28	9.40	10.68	60.00	-49.32	QP	P
12	27.9580	1.28	4.36	5.64	50.00	-44.36	AVG	P

Note: Level = Reading + Factor

Margin = Level – Limit



Power	: AC 120V	Pol/Phase	: LINE
Test Mode 1	: 802.11n HT20, CH1	Temperature	: 26 °C
Test Date	: Jul. 05, 2012	Humidity	: 60 %
Memo	: Adapter: DVE \ DSC-6PFA-05 FUS 050100		

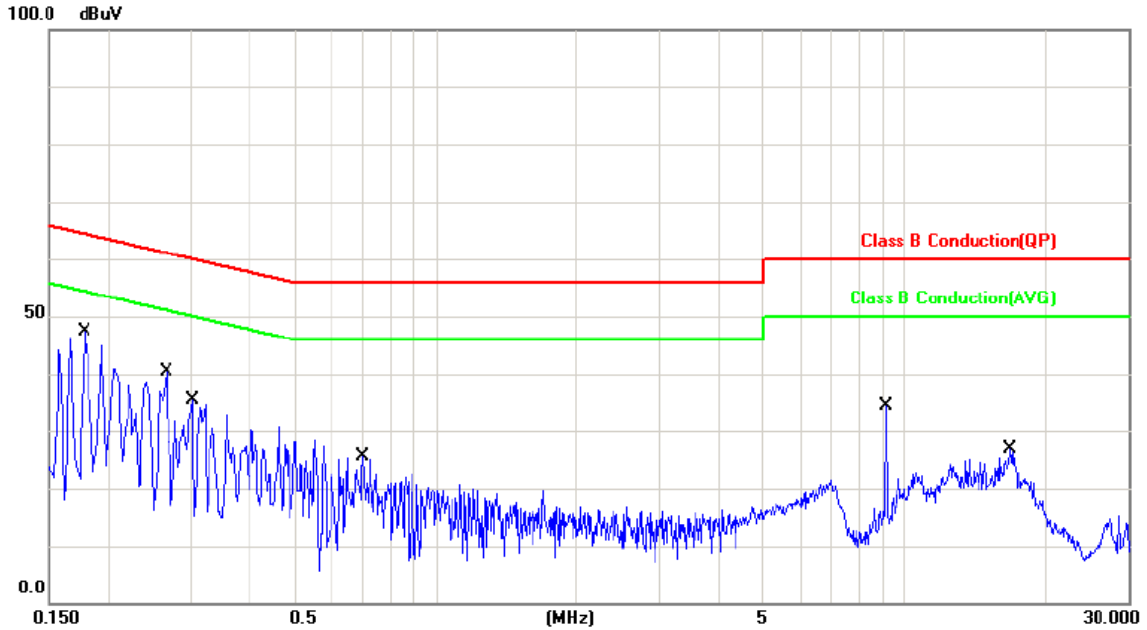

No.	Frequency (MHz)	Factor (dBuV)	Reading (dBuV)	Level (dBuV)	Limit (dBuV)	Margin (dB)	Detector	P/F
1	0.1780	0.12	40.63	40.75	64.57	-23.82	QP	P
2	0.1780	0.12	23.51	23.63	54.57	-30.94	AVG	P
3	0.2660	0.12	42.32	42.44	61.24	-18.80	QP	P
4	0.2660	0.12	36.46	36.58	51.24	-14.66	AVG	P
5	0.3020	0.12	28.43	28.55	60.19	-31.64	QP	P
6	0.3020	0.12	15.29	15.41	50.19	-34.78	AVG	P
7	0.6980	0.16	26.54	26.70	56.00	-29.30	QP	P
8	0.6980	0.16	20.47	20.63	46.00	-25.37	AVG	P
9	9.1220	0.55	15.25	15.80	60.00	-44.20	QP	P
10	9.1220	0.55	10.71	11.26	50.00	-38.74	AVG	P
11	16.7860	0.86	21.50	22.36	60.00	-37.64	QP	P
12	16.7860	0.86	15.34	16.20	50.00	-33.80	AVG	P

Note: Level = Reading + Factor  
Margin = Level – Limit





Power	: AC 120V	Pol/Phase	: NEUTRAL
Test Mode 1	: 802.11n HT20, CH1	Temperature	: 26 °C
Test Date	: Jul. 05, 2012	Humidity	: 60 %
Memo	: Adapter: DVE \ DSC-6PFA-05 FUS 050100		

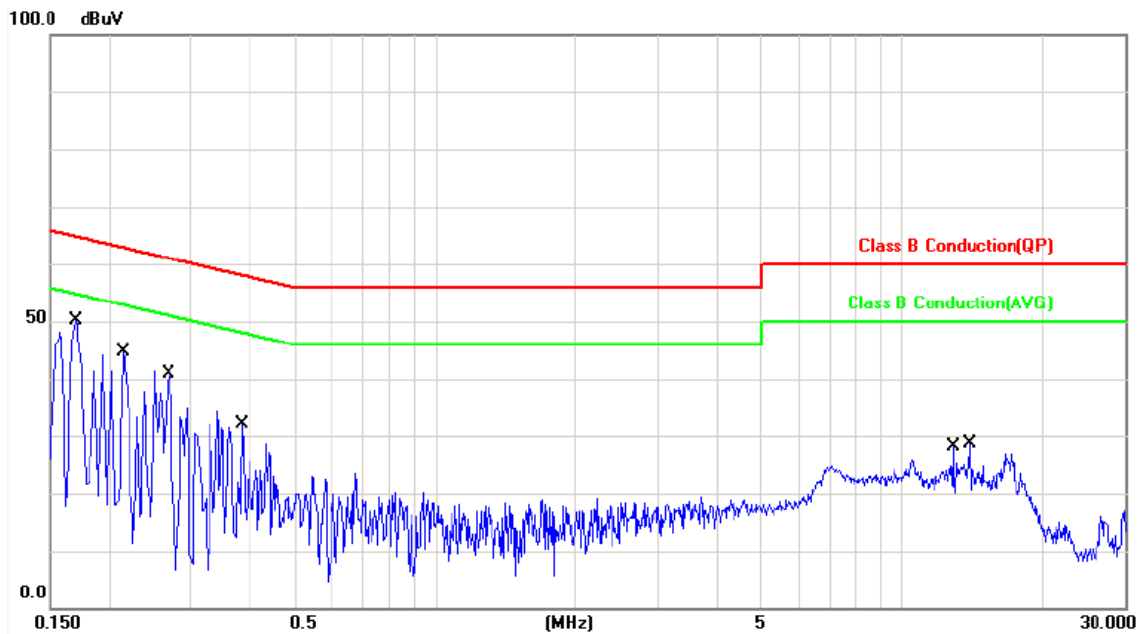

No.	Frequency (MHz)	Factor (dBuV)	Reading (dBuV)	Level (dBuV)	Limit (dBuV)	Margin (dB)	Detector	P/F
1	0.1700	0.12	48.52	48.64	64.96	-16.32	QP	P
2	0.1700	0.12	32.34	32.46	54.96	-22.50	AVG	P
3	0.2140	0.12	40.11	40.23	63.04	-22.81	QP	P
4	0.2140	0.12	28.51	28.63	53.04	-24.41	AVG	P
5	0.2700	0.12	35.52	35.64	61.12	-25.48	QP	P
6	0.2700	0.12	22.66	22.78	51.12	-28.34	AVG	P
7	0.3860	0.13	26.45	26.58	58.15	-31.57	QP	P
8	0.3860	0.13	19.81	19.94	48.15	-28.21	AVG	P
9	12.8940	0.70	19.64	20.34	60.00	-39.66	QP	P
10	12.8940	0.70	14.89	15.59	50.00	-34.41	AVG	P
11	13.9580	0.74	19.43	20.17	60.00	-39.83	QP	P
12	13.9580	0.74	14.55	15.29	50.00	-34.71	AVG	P

Note: Level = Reading + Factor  
Margin = Level – Limit



Power	: AC 120V	Pol/Phase	: LINE
Test Mode 1	: 802.11n HT40, CH3	Temperature	: 26 °C
Test Date	: Jul. 05, 2012	Humidity	: 60 %
Memo	: Adapter: DVE \ DSC-6PFA-05 FUS 050100		

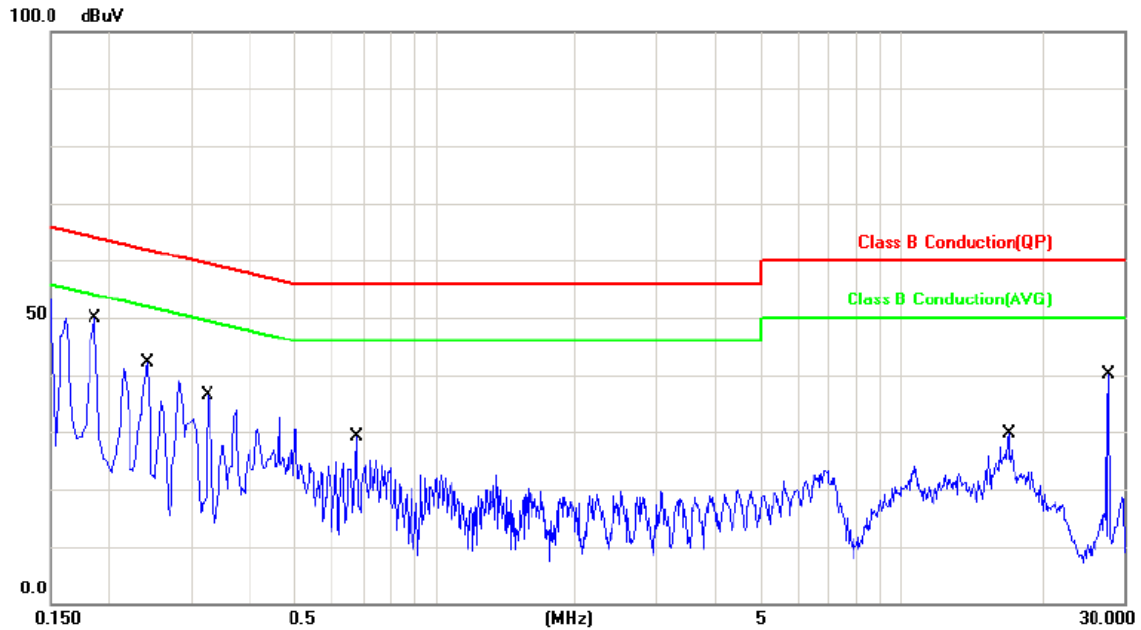

No.	Frequency (MHz)	Factor (dBuV)	Reading (dBuV)	Level (dBuV)	Limit (dBuV)	Margin (dB)	Detector	P/F
1	0.1860	0.12	45.43	45.55	64.21	-18.66	QP	P
2	0.1860	0.12	33.55	33.67	54.21	-20.54	AVG	P
3	0.2420	0.12	36.37	36.49	62.02	-25.53	QP	P
4	0.2420	0.12	22.64	22.76	52.02	-29.26	AVG	P
5	0.3260	0.12	32.51	32.63	59.55	-26.92	QP	P
6	0.3260	0.12	19.25	19.37	49.55	-30.18	AVG	P
7	0.6780	0.15	26.77	26.92	56.00	-29.08	QP	P
8	0.6780	0.15	25.63	25.78	46.00	-20.22	AVG	P
9	16.9740	0.87	22.45	23.32	60.00	-36.68	QP	P
10	16.9740	0.87	17.47	18.34	50.00	-31.66	AVG	P
11	27.9580	1.28	18.49	19.77	60.00	-40.23	QP	P
12	27.9580	1.28	14.38	15.66	50.00	-34.34	AVG	P

Note: Level = Reading + Factor  
Margin = Level – Limit



Power	: AC 120V	Pol/Phase	: NEUTRAL
Test Mode 1	: 802.11n HT40, CH3	Temperature	: 26 °C
Test Date	: Jul. 05, 2012	Humidity	: 60 %
Memo	: Adapter: DVE \ DSC-6PFA-05 FUS 050100		

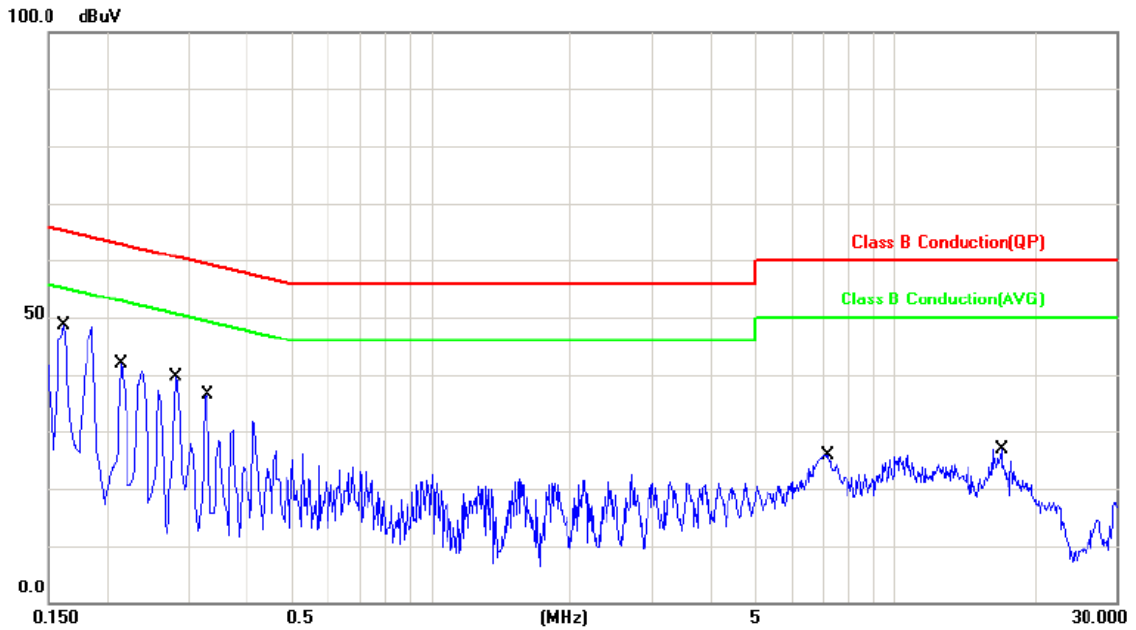

No.	Frequency (MHz)	Factor (dBuV)	Reading (dBuV)	Level (dBuV)	Limit (dBuV)	Margin (dB)	Detector	P/F
1	0.1620	0.12	48.52	48.64	65.36	-16.72	QP	P
2	0.1620	0.12	35.36	35.48	55.36	-19.88	AVG	P
3	0.2140	0.12	40.51	40.63	63.04	-22.41	QP	P
4	0.2140	0.12	25.25	25.37	53.04	-27.67	AVG	P
5	0.2819	0.12	36.52	36.64	60.76	-24.12	QP	P
6	0.2819	0.12	28.46	28.58	50.76	-22.18	AVG	P
7	0.3300	0.12	29.51	29.63	59.45	-29.82	QP	P
8	0.3300	0.12	18.34	18.46	49.45	-30.99	AVG	P
9	7.2100	0.47	24.54	25.01	60.00	-34.99	QP	P
10	7.2100	0.47	22.26	22.73	50.00	-27.27	AVG	P
11	16.9740	0.87	20.44	21.31	60.00	-38.69	QP	P
12	16.9740	0.87	15.30	16.17	50.00	-33.83	AVG	P

Note: Level = Reading + Factor

Margin = Level – Limit



Power	: AC 120V	Pol/Phase	: LINE
Test Mode 2	: 802.11g, CH1	Temperature	: 26 °C
Test Date	: Jul. 05, 2012	Humidity	: 60 %
Memo	: Adapter: AMIGO \ AMS47-0501200FU		

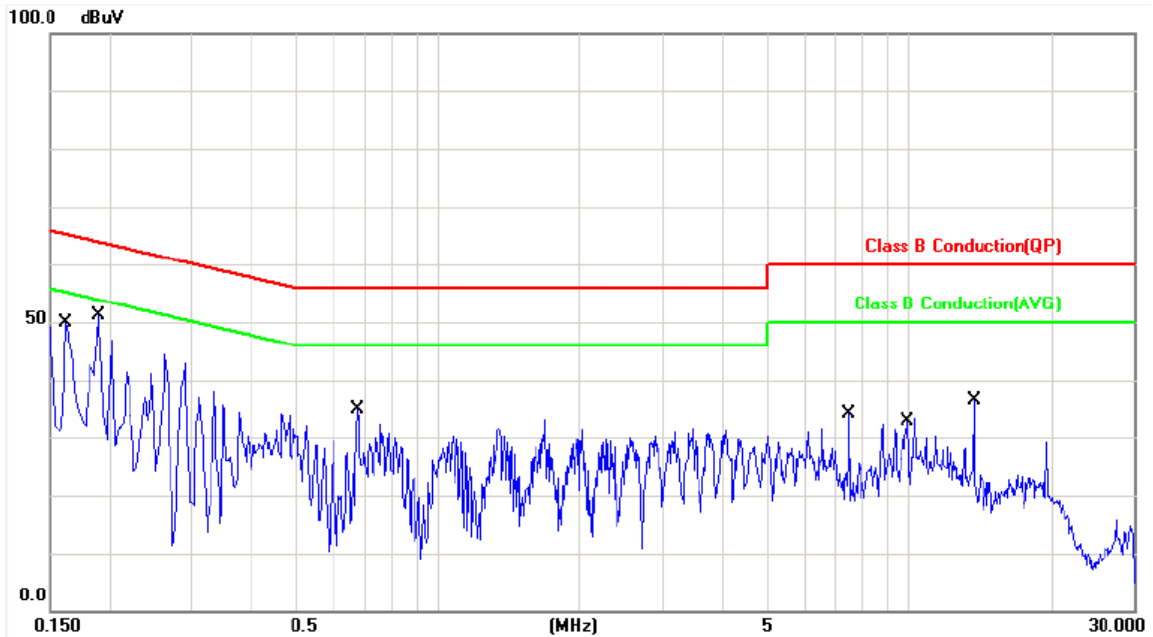

No.	Frequency (MHz)	Factor (dBuV)	Reading (dBuV)	Level (dBuV)	Limit (dBuV)	Margin (dB)	Detector	P/F
1	0.1620	0.12	46.31	46.43	65.36	-18.93	QP	P
2	0.1620	0.12	36.34	36.46	55.36	-18.90	AVG	P
3	0.1900	0.12	46.39	46.51	64.03	-17.52	QP	P
4	0.1900	0.12	36.73	36.85	54.03	-17.18	AVG	P
5	0.6740	0.15	34.84	34.99	56.00	-21.01	QP	P
6	0.6740	0.15	33.64	33.79	46.00	-12.21	AVG	P
7	7.4820	0.48	30.32	30.80	60.00	-29.20	QP	P
8	7.4820	0.48	15.51	15.99	50.00	-34.01	AVG	P
9	9.9140	0.58	18.46	19.04	60.00	-40.96	QP	P
10	9.9140	0.58	9.41	9.99	50.00	-40.01	AVG	P
11	13.7140	0.74	28.33	29.07	60.00	-30.93	QP	P
12	13.7140	0.74	14.45	15.19	50.00	-34.81	AVG	P

Note: Level = Reading + Factor  
Margin = Level – Limit



Power	: AC 120V	Pol/Phase	: NEUTRAL
Test Mode 2	: 802.11g, CH1	Temperature	: 26 °C
Test Date	: Jul. 05, 2012	Humidity	: 60 %
Memo	: Adapter: AMIGO \ AMS47-0501200FU		

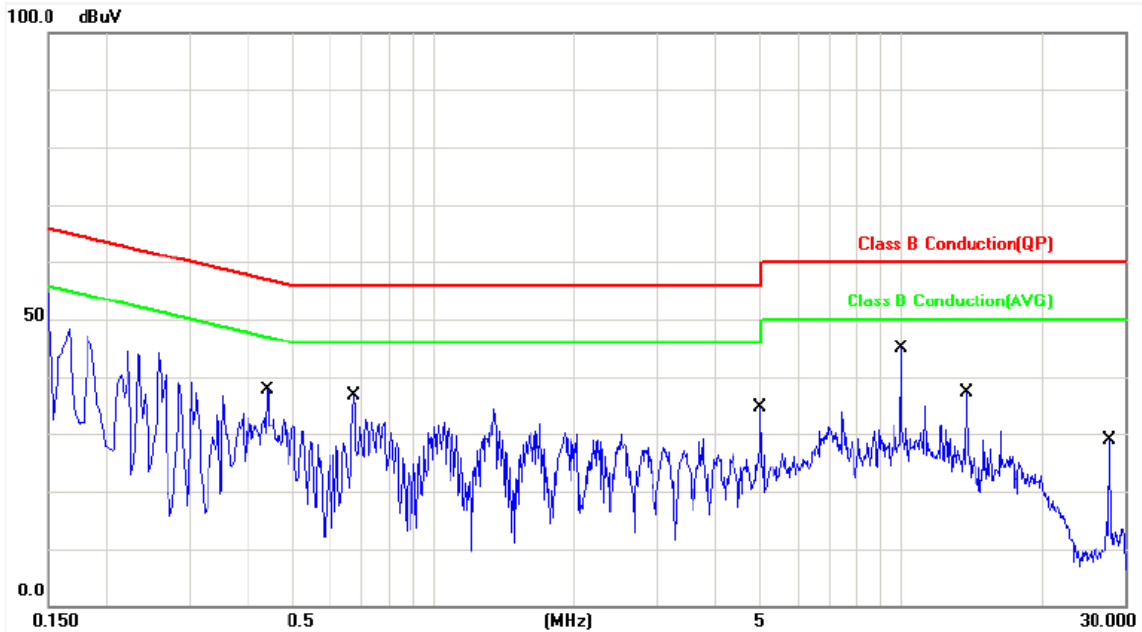

No.	Frequency (MHz)	Factor (dBuV)	Reading (dBuV)	Level (dBuV)	Limit (dBuV)	Margin (dB)	Detector	P/F
1	0.4420	0.13	32.38	32.51	57.02	-24.51	QP	P
2	0.4420	0.13	22.22	22.35	47.02	-24.67	AVG	P
3	0.6740	0.15	36.76	36.91	56.00	-19.09	QP	P
4	0.6740	0.15	33.54	33.69	46.00	-12.31	AVG	P
5	5.0020	0.39	28.43	28.82	60.00	-31.18	QP	P
6	5.0020	0.39	23.24	23.63	50.00	-26.37	AVG	P
7	10.0020	0.58	40.51	41.09	60.00	-18.91	QP	P
8	10.0020	0.58	28.41	28.99	50.00	-21.01	AVG	P
9	13.7540	0.74	22.72	23.46	60.00	-36.54	QP	P
10	13.7540	0.74	19.65	20.39	50.00	-29.61	AVG	P
11	27.9580	1.28	9.42	10.70	60.00	-49.30	QP	P
12	27.9580	1.28	4.33	5.61	50.00	-44.39	AVG	P

Note: Level = Reading + Factor  
Margin = Level – Limit



Power	: AC 120V	Pol/Phase	: LINE
Test Mode 2	: 802.11n HT20, CH1	Temperature	: 26 °C
Test Date	: Jul. 05, 2012	Humidity	: 60 %
Memo	: Adapter: AMIGO \ AMS47-0501200FU		

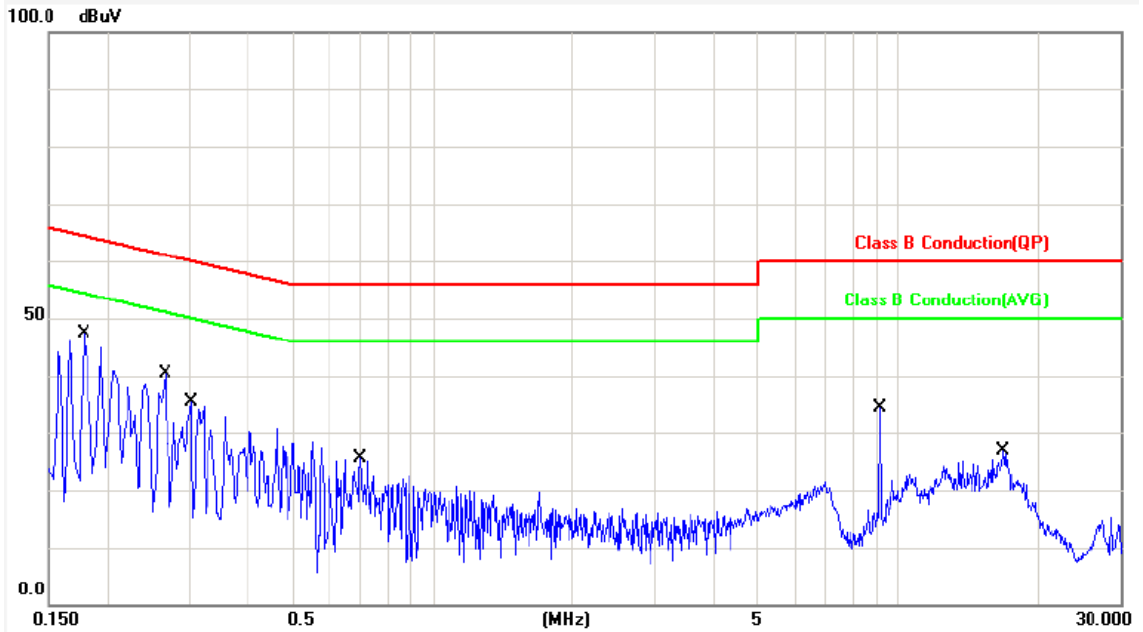

No.	Frequency (MHz)	Factor (dBuV)	Reading (dBuV)	Level (dBuV)	Limit (dBuV)	Margin (dB)	Detector	P/F
1	0.1780	0.12	40.34	40.46	64.57	-24.11	QP	P
2	0.1780	0.12	23.55	23.67	54.57	-30.90	AVG	P
3	0.2660	0.12	42.29	42.41	61.24	-18.83	QP	P
4	0.2660	0.12	36.54	36.66	51.24	-14.58	AVG	P
5	0.3020	0.12	28.61	28.73	60.19	-31.46	QP	P
6	0.3020	0.12	15.21	15.33	50.19	-34.86	AVG	P
7	0.6980	0.16	26.55	26.71	56.00	-29.29	QP	P
8	0.6980	0.16	20.43	20.59	46.00	-25.41	AVG	P
9	9.1220	0.55	15.36	15.91	60.00	-44.09	QP	P
10	9.1220	0.55	10.58	11.13	50.00	-38.87	AVG	P
11	16.7860	0.86	21.72	22.58	60.00	-37.42	QP	P
12	16.7860	0.86	15.49	16.35	50.00	-33.65	AVG	P

Note: Level = Reading + Factor  
Margin = Level – Limit



Power	: AC 120V	Pol/Phase	: NEUTRAL
Test Mode 2	: 802.11n HT20, CH1	Temperature	: 26 °C
Test Date	: Jul. 05, 2012	Humidity	: 60 %
Memo	: Adapter: AMIGO \ AMS47-0501200FU		

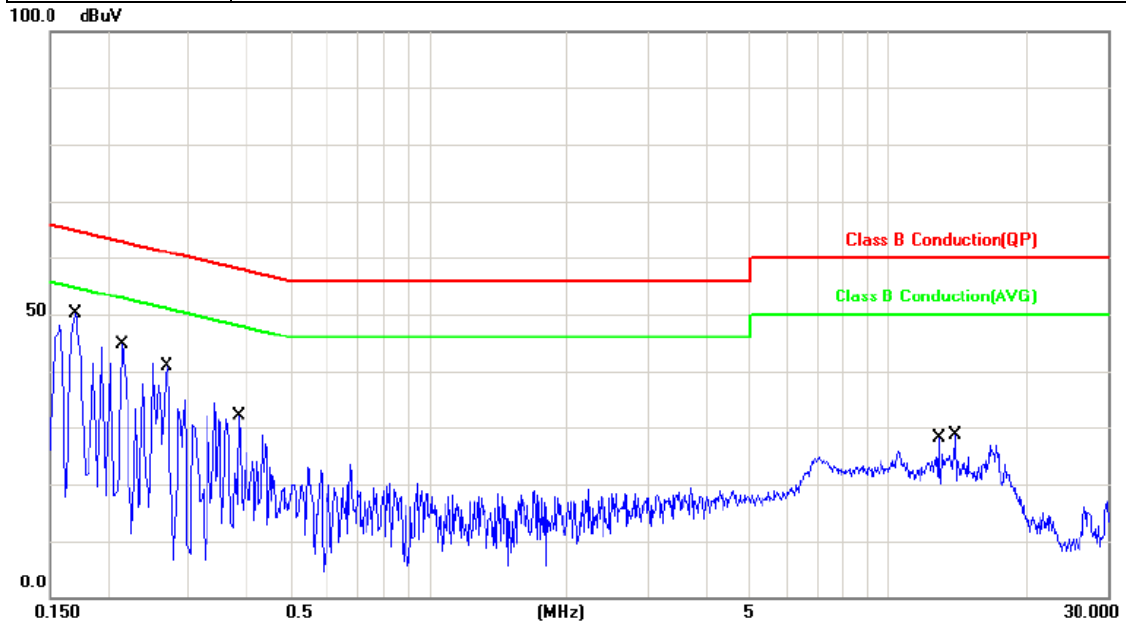

No.	Frequency (MHz)	Factor (dBuV)	Reading (dBuV)	Level (dBuV)	Limit (dBuV)	Margin (dB)	Detector	P/F
1	0.1700	0.12	48.43	48.55	64.96	-16.41	QP	P
2	0.1700	0.12	32.56	32.68	54.96	-22.28	AVG	P
3	0.2140	0.12	40.28	40.40	63.04	-22.64	QP	P
4	0.2140	0.12	28.43	28.55	53.04	-24.49	AVG	P
5	0.2700	0.12	35.51	35.63	61.12	-25.49	QP	P
6	0.2700	0.12	22.74	22.86	51.12	-28.26	AVG	P
7	0.3860	0.13	26.68	26.81	58.15	-31.34	QP	P
8	0.3860	0.13	19.55	19.68	48.15	-28.47	AVG	P
9	12.8940	0.70	19.34	20.04	60.00	-39.96	QP	P
10	12.8940	0.70	14.77	15.47	50.00	-34.53	AVG	P
11	13.9580	0.74	19.60	20.34	60.00	-39.66	QP	P
12	13.9580	0.74	14.47	15.21	50.00	-34.79	AVG	P

Note: Level = Reading + Factor  
Margin = Level – Limit



Power	: AC 120V	Pol/Phase	: LINE
Test Mode 2	: 802.11n HT40, CH3	Temperature	: 26 °C
Test Date	: Jul. 05, 2012	Humidity	: 60 %
Memo	: Adapter: AMIGO \ AMS47-0501200FU		

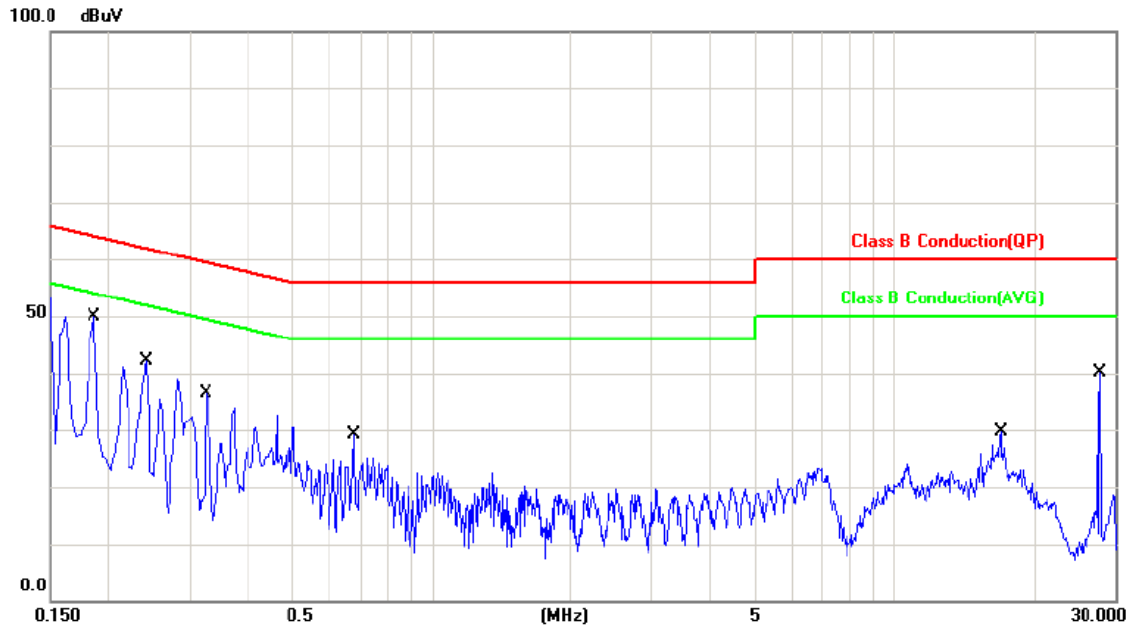

No.	Frequency (MHz)	Factor (dBuV)	Reading (dBuV)	Level (dBuV)	Limit (dBuV)	Margin (dB)	Detector	P/F
1	0.1860	0.12	45.46	45.58	64.21	-18.63	QP	P
2	0.1860	0.12	33.52	33.64	54.21	-20.57	AVG	P
3	0.2420	0.12	36.47	36.59	62.02	-25.43	QP	P
4	0.2420	0.12	22.50	22.62	52.02	-29.40	AVG	P
5	0.3260	0.12	32.67	32.79	59.55	-26.76	QP	P
6	0.3260	0.12	19.42	19.54	49.55	-30.01	AVG	P
7	0.6780	0.15	26.94	27.09	56.00	-28.91	QP	P
8	0.6780	0.15	25.61	25.76	46.00	-20.24	AVG	P
9	16.9740	0.87	22.53	23.40	60.00	-36.60	QP	P
10	16.9740	0.87	17.74	18.61	50.00	-31.39	AVG	P
11	27.9580	1.28	18.61	19.89	60.00	-40.11	QP	P
12	27.9580	1.28	14.38	15.66	50.00	-34.34	AVG	P

Note: Level = Reading + Factor  
Margin = Level – Limit





Power	: AC 120V	Pol/Phase	: NEUTRAL
Test Mode 2	: 802.11n HT40, CH3	Temperature	: 26 °C
Test Date	: Jul. 05, 2012	Humidity	: 60 %
Memo	: Adapter: AMIGO \ AMS47-0501200FU		

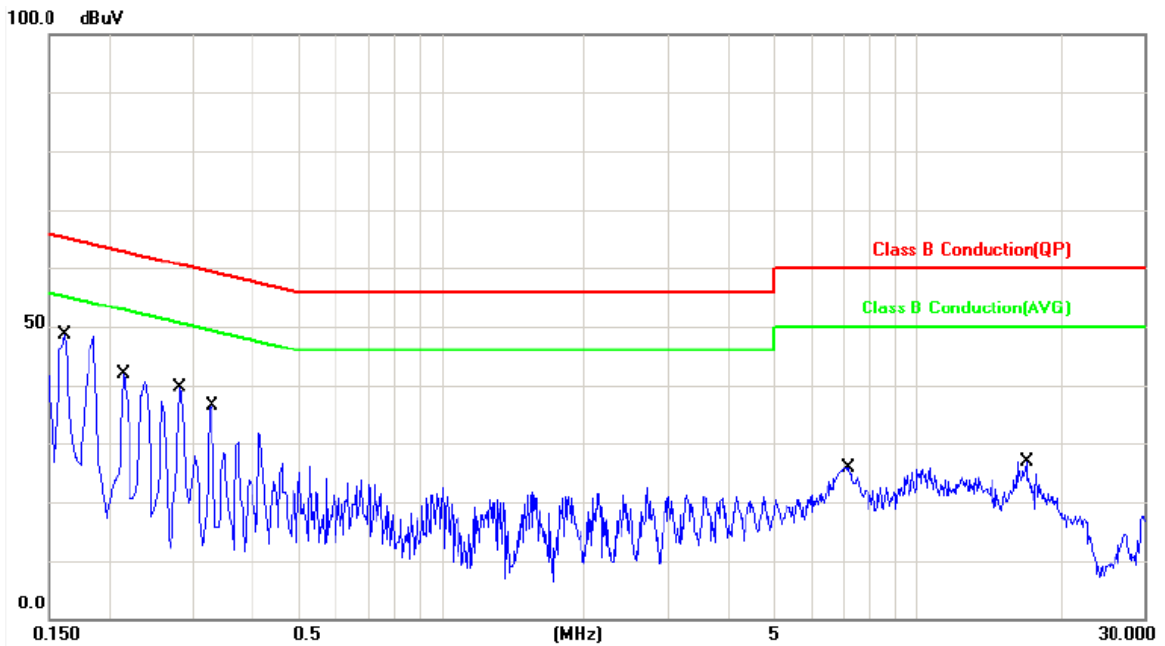

No.	Frequency (MHz)	Factor (dBuV)	Reading (dBuV)	Level (dBuV)	Limit (dBuV)	Margin (dB)	Detector	P/F
1	0.1620	0.12	48.41	48.53	65.36	-16.83	QP	P
2	0.1620	0.12	35.22	35.34	55.36	-20.02	AVG	P
3	0.2140	0.12	40.58	40.70	63.04	-22.34	QP	P
4	0.2140	0.12	25.21	25.33	53.04	-27.71	AVG	P
5	0.2819	0.12	36.31	36.43	60.76	-24.33	QP	P
6	0.2819	0.12	28.43	28.55	50.76	-22.21	AVG	P
7	0.3300	0.12	29.41	29.53	59.45	-29.92	QP	P
8	0.3300	0.12	18.49	18.61	49.45	-30.84	AVG	P
9	7.2100	0.47	24.43	24.90	60.00	-35.10	QP	P
10	7.2100	0.47	22.50	22.97	50.00	-27.03	AVG	P
11	16.9740	0.87	20.41	21.28	60.00	-38.72	QP	P
12	16.9740	0.87	15.34	16.21	50.00	-33.79	AVG	P

Note: Level = Reading + Factor

Margin = Level – Limit



Power	: AC 120V	Pol/Phase	: LINE
Test Mode 3	: 802.11g, CH1	Temperature	: 26 °C
Test Date	: Jul. 05, 2012	Humidity	: 60 %
Memo	: Adapter: JENTEC \ CF0605-B		

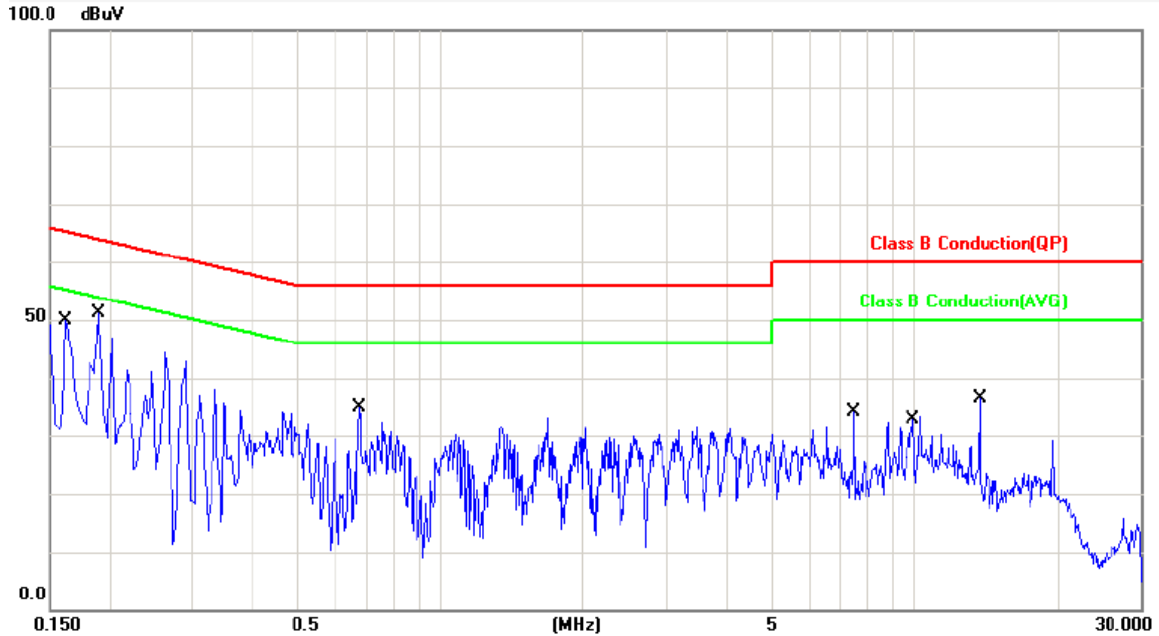

No.	Frequency (MHz)	Factor (dBuV)	Reading (dBuV)	Level (dBuV)	Limit (dBuV)	Margin (dB)	Detector	P/F
1	0.1620	0.12	46.27	46.39	65.36	-18.97	QP	P
2	0.1620	0.12	36.31	36.43	55.36	-18.93	AVG	P
3	0.1900	0.12	46.25	46.37	64.03	-17.66	QP	P
4	0.1900	0.12	36.68	36.80	54.03	-17.23	AVG	P
5	0.6740	0.15	34.74	34.89	56.00	-21.11	QP	P
6	0.6740	0.15	33.53	33.68	46.00	-12.32	AVG	P
7	7.4820	0.48	30.48	30.96	60.00	-29.04	QP	P
8	7.4820	0.48	15.62	16.10	50.00	-33.90	AVG	P
9	9.9140	0.58	18.37	18.95	60.00	-41.05	QP	P
10	9.9140	0.58	9.48	10.06	50.00	-39.94	AVG	P
11	13.7140	0.74	28.20	28.94	60.00	-31.06	QP	P
12	13.7140	0.74	14.14	14.88	50.00	-35.12	AVG	P

Note: Level = Reading + Factor  
Margin = Level – Limit



Power	: AC 120V	Pol/Phase	: NEUTRAL
Test Mode 3	: 802.11g, CH1	Temperature	: 26 °C
Test Date	: Jul. 05, 2012	Humidity	: 60 %
Memo	: Adapter: JENTEC \ CF0605-B		

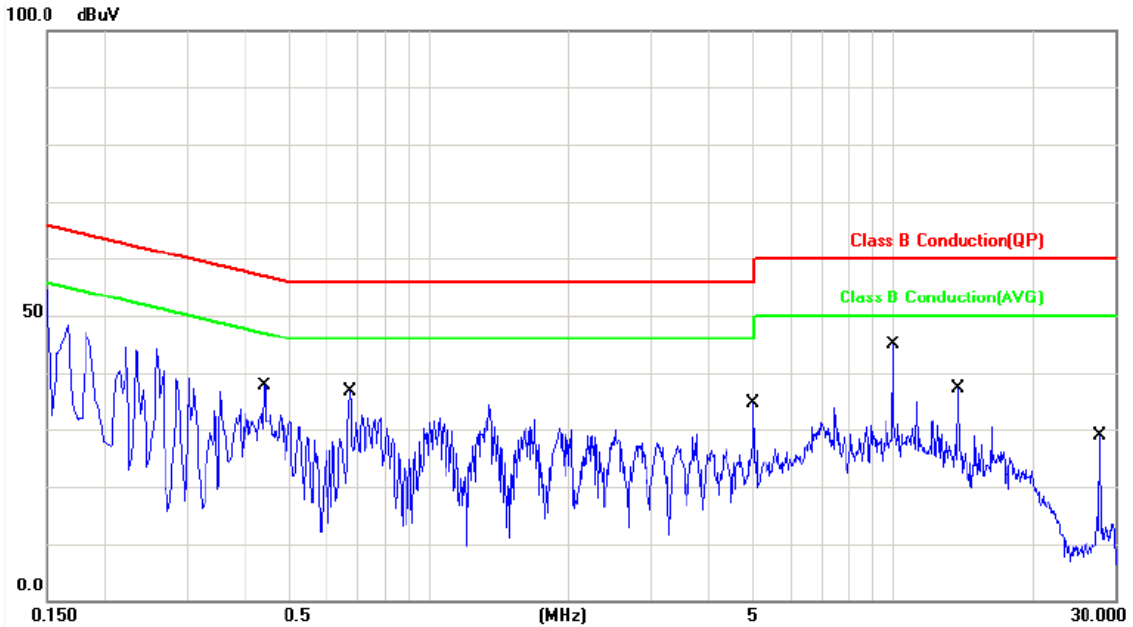

No.	Frequency (MHz)	Factor (dBuV)	Reading (dBuV)	Level (dBuV)	Limit (dBuV)	Margin (dB)	Detector	P/F
1	0.4420	0.13	32.15	32.28	57.02	-24.74	QP	P
2	0.4420	0.13	22.35	22.48	47.02	-24.54	AVG	P
3	0.6740	0.15	36.65	36.80	56.00	-19.20	QP	P
4	0.6740	0.15	33.48	33.63	46.00	-12.37	AVG	P
5	5.0020	0.39	28.52	28.91	60.00	-31.09	QP	P
6	5.0020	0.39	23.33	23.72	50.00	-26.28	AVG	P
7	10.0020	0.58	40.55	41.13	60.00	-18.87	QP	P
8	10.0020	0.58	28.47	29.05	50.00	-20.95	AVG	P
9	13.7540	0.74	22.69	23.43	60.00	-36.57	QP	P
10	13.7540	0.74	19.71	20.45	50.00	-29.55	AVG	P
11	27.9580	1.28	9.51	10.79	60.00	-49.21	QP	P
12	27.9580	1.28	4.29	5.57	50.00	-44.43	AVG	P

Note: Level = Reading + Factor

Margin = Level – Limit



Power	: AC 120V	Pol/Phase	: LINE
Test Mode 3	: 802.11n HT20, CH1	Temperature	: 26 °C
Test Date	: Jul. 05, 2012	Humidity	: 60 %
Memo	: Adapter: JENTEC \ CF0605-B		

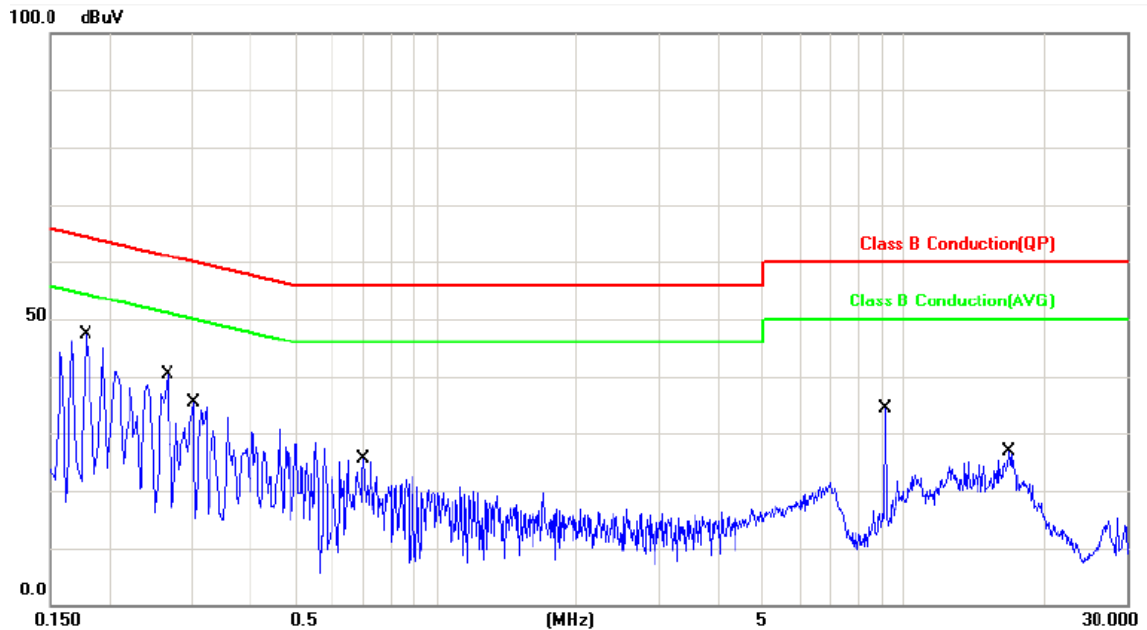

No.	Frequency (MHz)	Factor (dBuV)	Reading (dBuV)	Level (dBuV)	Limit (dBuV)	Margin (dB)	Detector	P/F
1	0.1780	0.12	40.58	40.70	64.57	-23.87	QP	P
2	0.1780	0.12	23.62	23.74	54.57	-30.83	AVG	P
3	0.2660	0.12	42.41	42.53	61.24	-18.71	QP	P
4	0.2660	0.12	36.39	36.51	51.24	-14.73	AVG	P
5	0.3020	0.12	28.50	28.62	60.19	-31.57	QP	P
6	0.3020	0.12	15.21	15.33	50.19	-34.86	AVG	P
7	0.6980	0.16	26.67	26.83	56.00	-29.17	QP	P
8	0.6980	0.16	20.52	20.68	46.00	-25.32	AVG	P
9	9.1220	0.55	15.30	15.85	60.00	-44.15	QP	P
10	9.1220	0.55	10.78	11.33	50.00	-38.67	AVG	P
11	16.7860	0.86	21.69	22.55	60.00	-37.45	QP	P
12	16.7860	0.86	15.54	16.40	50.00	-33.60	AVG	P

Note: Level = Reading + Factor  
Margin = Level – Limit



Power	: AC 120V	Pol/Phase	: NEUTRAL
Test Mode 3	: 802.11n HT20, CH1	Temperature	: 26 °C
Test Date	: Jul. 05, 2012	Humidity	: 60 %
Memo	: Adapter: JENTEC \ CF0605-B		

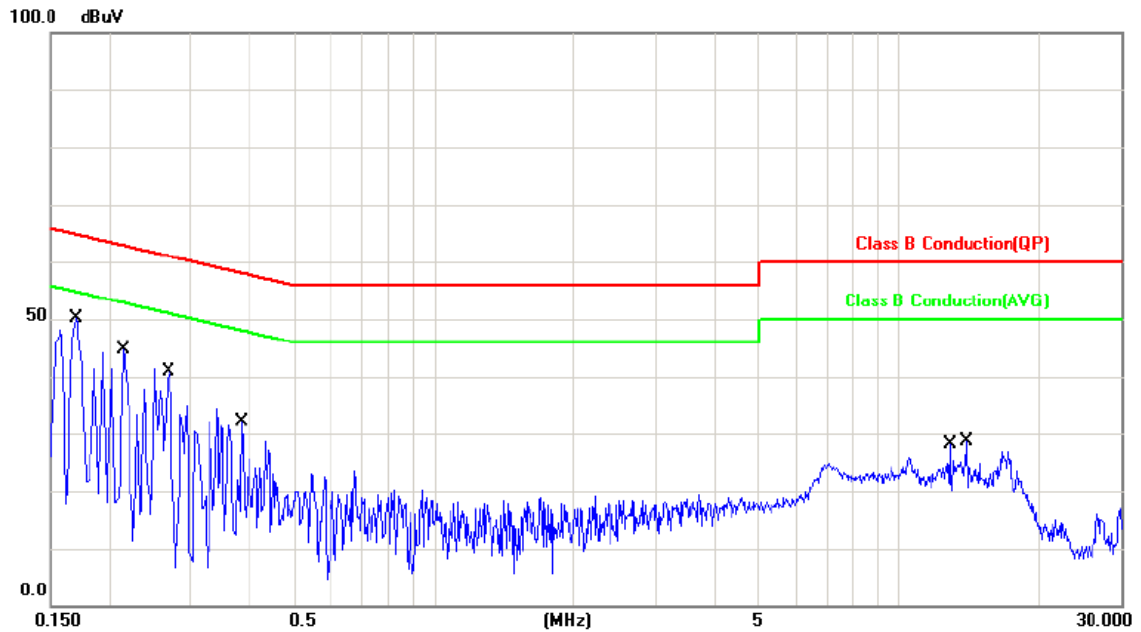

No.	Frequency (MHz)	Factor (dBuV)	Reading (dBuV)	Level (dBuV)	Limit (dBuV)	Margin (dB)	Detector	P/F
1	0.1700	0.12	48.36	48.48	64.96	-16.48	QP	P
2	0.1700	0.12	32.49	32.61	54.96	-22.35	AVG	P
3	0.2140	0.12	40.18	40.30	63.04	-22.74	QP	P
4	0.2140	0.12	28.32	28.44	53.04	-24.60	AVG	P
5	0.2700	0.12	35.46	35.58	61.12	-25.54	QP	P
6	0.2700	0.12	22.78	22.90	51.12	-28.22	AVG	P
7	0.3860	0.13	26.51	26.64	58.15	-31.51	QP	P
8	0.3860	0.13	19.49	19.62	48.15	-28.53	AVG	P
9	12.8940	0.70	19.60	20.30	60.00	-39.70	QP	P
10	12.8940	0.70	14.74	15.44	50.00	-34.56	AVG	P
11	13.9580	0.74	19.39	20.13	60.00	-39.87	QP	P
12	13.9580	0.74	14.41	15.15	50.00	-34.85	AVG	P

Note: Level = Reading + Factor  
Margin = Level – Limit



Power	: AC 120V	Pol/Phase	: LINE
Test Mode 3	: 802.11n HT40, CH3	Temperature	: 26 °C
Test Date	: Jul. 05, 2012	Humidity	: 60 %
Memo	: Adapter: JENTEC \ CF0605-B		

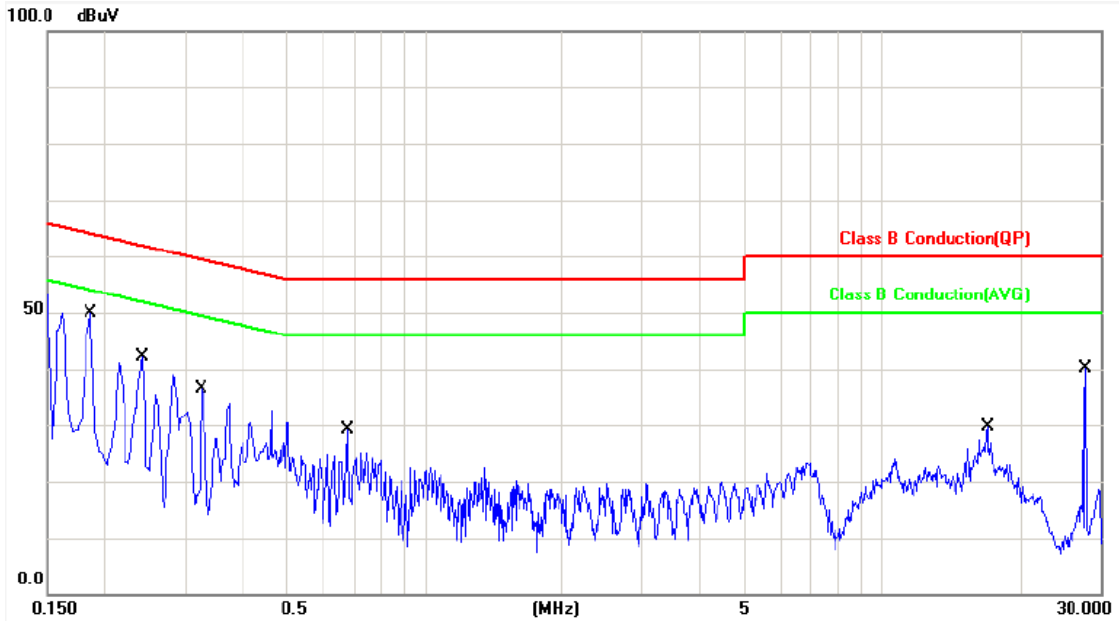

No.	Frequency (MHz)	Factor (dBuV)	Reading (dBuV)	Level (dBuV)	Limit (dBuV)	Margin (dB)	Detector	P/F
1	0.1860	0.12	45.37	45.49	64.21	-18.72	QP	P
2	0.1860	0.12	33.49	33.61	54.21	-20.60	AVG	P
3	0.2420	0.12	36.41	36.53	62.02	-25.49	QP	P
4	0.2420	0.12	22.42	22.54	52.02	-29.48	AVG	P
5	0.3260	0.12	32.56	32.68	59.55	-26.87	QP	P
6	0.3260	0.12	19.33	19.45	49.55	-30.10	AVG	P
7	0.6780	0.15	26.85	27.00	56.00	-29.00	QP	P
8	0.6780	0.15	25.59	25.74	46.00	-20.26	AVG	P
9	16.9740	0.87	22.47	23.34	60.00	-36.66	QP	P
10	16.9740	0.87	17.63	18.50	50.00	-31.50	AVG	P
11	27.9580	1.28	18.52	19.80	60.00	-40.20	QP	P
12	27.9580	1.28	14.50	15.78	50.00	-34.22	AVG	P

Note: Level = Reading + Factor  
Margin = Level – Limit



Power	: AC 120V	Pol/Phase	: NEUTRAL
Test Mode 3	: 802.11n HT40, CH3	Temperature	: 26 °C
Test Date	: Jul. 05, 2012	Humidity	: 60 %
Memo	: Adapter: JENTEC \ CF0605-B		

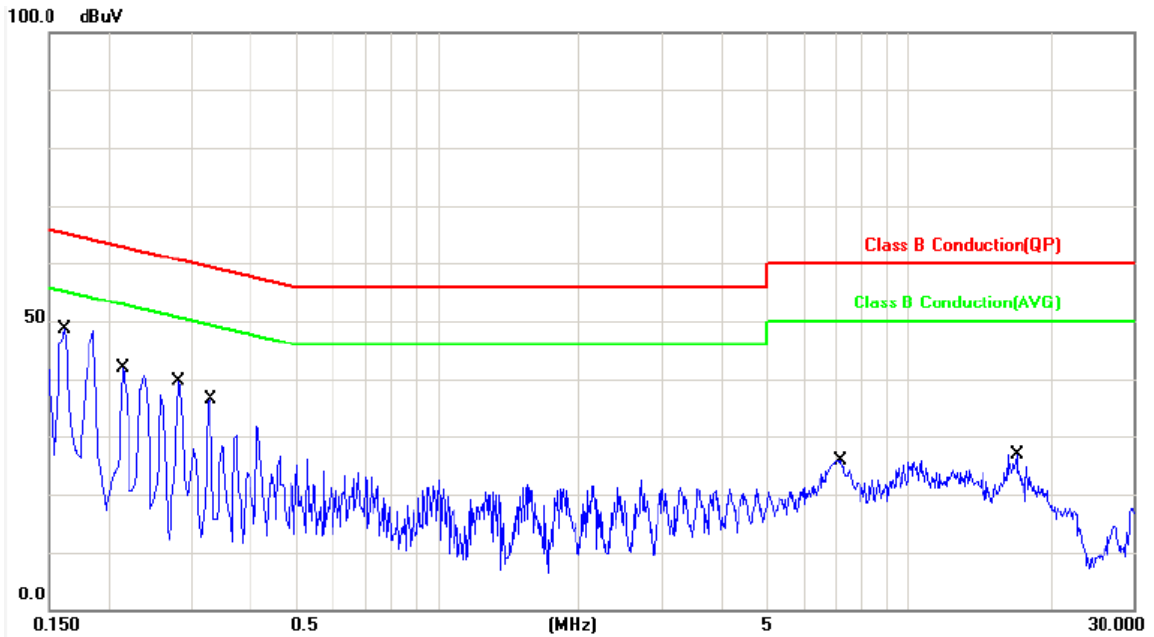

No.	Frequency (MHz)	Factor (dBuV)	Reading (dBuV)	Level (dBuV)	Limit (dBuV)	Margin (dB)	Detector	P/F
1	0.1620	0.12	48.35	48.47	65.36	-16.89	QP	P
2	0.1620	0.12	35.18	35.30	55.36	-20.06	AVG	P
3	0.2140	0.12	40.47	40.59	63.04	-22.45	QP	P
4	0.2140	0.12	25.19	25.31	53.04	-27.73	AVG	P
5	0.2819	0.12	36.46	36.58	60.76	-24.18	QP	P
6	0.2819	0.12	28.27	28.39	50.76	-22.37	AVG	P
7	0.3300	0.12	29.33	29.45	59.45	-30.00	QP	P
8	0.3300	0.12	18.57	18.69	49.45	-30.76	AVG	P
9	7.2100	0.47	24.32	24.79	60.00	-35.21	QP	P
10	7.2100	0.47	22.47	22.94	50.00	-27.06	AVG	P
11	16.9740	0.87	20.36	21.23	60.00	-38.77	QP	P
12	16.9740	0.87	15.41	16.28	50.00	-33.72	AVG	P

Note: Level = Reading + Factor

Margin = Level – Limit



## 5. Test of Radiated Emission

### 5.1 Test Limit

In any 100kHz bandwidth outside the frequency band in which the spread spectrum or digitally modulated intentional radiator is operating, the radio frequency power that is produced by the intentional radiator shall be at least 20dB below that in the 100kHz bandwidth within the band that contains the highest level of the desired power, based on either an RF conducted or a radiated measurement. If the transmitter measurement is based on the maximum conducted output power, the attenuation required under this paragraph shall be 30dB instead of 20dB. In addition, radiated emissions which fall in section 15.205(a) the restricted bands must also comply with the radiated emission limit specified in section 15.209(a).

Frequency (MHz)	Field Strength (microvolt/meter)	Measurement Distance (meters)
0.009 ~ 0.490	2400/F(kHz)	300
0.490 ~ 1.705	24000/F(kHz)	30
1.705 ~ 30.0	30	30
30 ~ 88	100	3
88 ~ 216	150	3
216 ~ 960	200	3
Above 960	500	3

### 5.2 Test Procedures

- The EUT was placed on a rotatable table top 0.8 meter above ground.
- The EUT was set 3 meters from the interference receiving antenna which was mounted on the top of a variable height antenna tower.
- The table was rotated 360 degrees to determine the position of the highest radiation.
- The antenna is a broadband antenna and its height is varied between one meter and four meters above ground to find the maximum value of the field strength both horizontal polarization and vertical polarization of the antenna are set to make the measurement.
- For each suspected emission the EUT was arranged to its worst case and then tune the antenna tower (from 1 M to 4 M) and turn table (from 0 degree to 360 degrees) to find the maximum reading.
- Set the test-receiver system to Peak or CISPR quasi-peak Detect Function and specified bandwidth with Maximum Hold Mode.
- If the emission level of the EUT in peak mode was 3 dB lower than the limit specified, then testing will be stopped and peak values of EUT will be reported, otherwise, the emissions which do not have 3 dB margin will be repeated one by one using the quasi-peak method and reported.
- For testing above 1GHz, the emission level of the EUT in peak mode was 20dB lower than average limit (that means the emission level in peak mode also complies with the limit in average mode), then testing will be stopped and peak values of EUT will be reported, otherwise, the emissions will be measured in average mode again and reported.
- "Cone of radiation" has been considered to be 3dB bandwidth of the measurement antenna.





### 5.3 Typical Test Setup

For radiated emissions below 30MHz

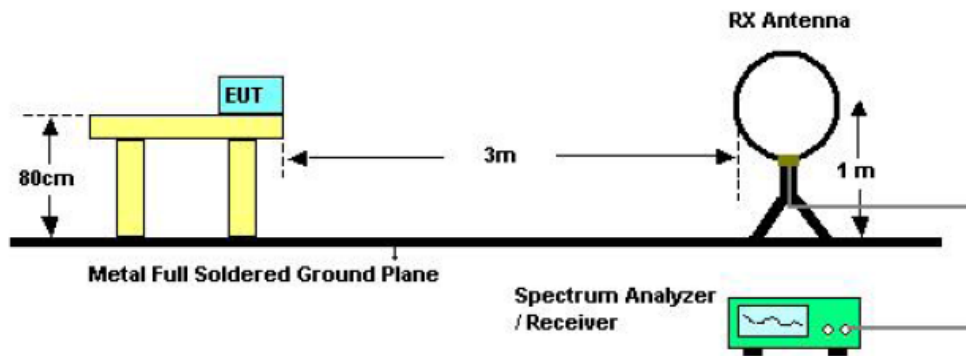

For radiated emissions above 30MHz

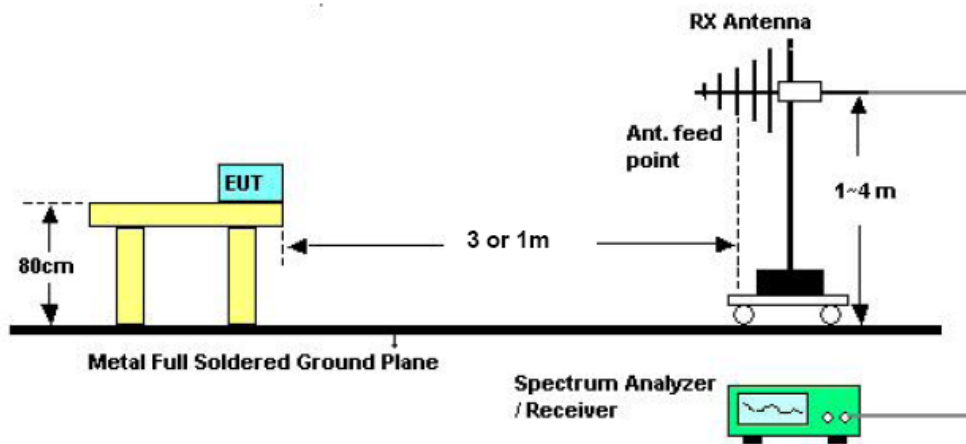

Above 10 GHz shall be extrapolated to the specified distance using an extrapolation factor of 20 dB/decade from 3m to 1m.

Distance extrapolation factor =  $20 \log(\text{specific distance [3m]} / \text{test distance [1m]})$  (dB);

Limit line = specific limits (dBuV) + distance extrapolation factor [9.54 dB].

### 5.4 Measurement Equipment

Instrument/Ancillary	Manufacturer	Model No.	Serial No.	Calibration Date	Valid Date
EMI Receiver	R&S	ESCI	100821	2012/01/31	2013/01/30
Amplifier	QuieTek	AP/0100A	CHM0906075	2012/01/13	2013/01/12
Signal Generator	HP	8648B	3629U00612	2012/01/11	2013/01/10
Bilog Antenna	Schwarzbeck	VULB 9168	275	2012/03/23	2013/03/22
Spectrum Analyzer	R&S	FSP40	100047	2012/03/01	2013/02/28
Horn Antenna	EMCO	3115	31589	2012/03/01	2013/02/28
Preamplifier	Agilent	8449B	3008A01954	2012/02/29	2013/02/28
Loop Antenna	EMCO	6507	40855	2012/02/29	2013/02/28



### 5.5 Test Result and Data (9kHz ~ 30MHz)

The 9kHz - 30MHz spurious emission is under limit 20dB more.

### 5.6 Test Result and Data

Power	: AC 120V	Pol/Phase	: VERTICAL
Test Mode 1	: 802.11g, CH1	Temperature	: 25 °C
Adapter	: DVE \ DSC-6PFA-05 FUS 050100	Humidity	: 67 %

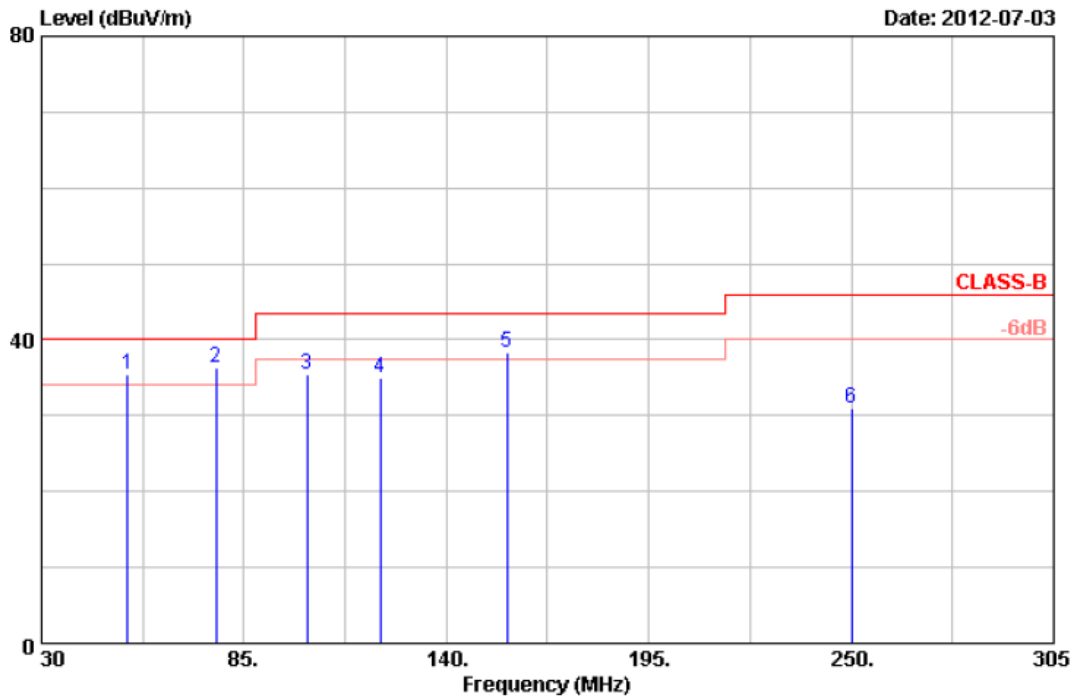

Item	Freq	Read Value	Factor	Result	Limit	Margin	Remark	Ant Pos	Tab Pos
	MHz	dBuV	dB/m	dBuV/m	dBuV/m	dB		cm	Deg
1	53.38	46.11	-10.68	35.43	40.00	-4.57	QP	100	360
2	77.30	45.14	-8.84	36.30	40.00	-3.70	Peak	100	360
3	102.05	43.87	-8.39	35.48	43.50	-8.02	Peak	100	360
4	122.13	39.80	-4.76	35.04	43.50	-8.46	Peak	100	360
5	156.50	50.65	-12.27	38.38	43.50	-5.12	Peak	100	360
6	250.00	42.55	-11.52	31.03	46.00	-14.97	Peak	100	360

Notes:

1. Result = Read Value + Factor
2. Factor = Antenna Factor + Cable Loss - Amplifier
3. The resolution bandwidth of test receiver/spectrum analyzer is 120KHz and video bandwidth is 300kHz for Peak detection and Quasi-peak detection at frequency below 1GHz.
4. All below 1GHz configurations are pretested among available 802.11b/g/n modes and found that the worst cases are on channel 1 of 802.11g & n20 mode and Channel 3 for n40 mode. Only worst case data concluded above were presented in this test report.
5. The data is worse case.



Power	: AC 120V	Pol/Phase	: VERTICAL
Test Mode 1	: 802.11g, CH1	Temperature	: 25 °C
Adapter	: DVE \ DSC-6PFA-05 FUS 050100	Humidity	: 67 %

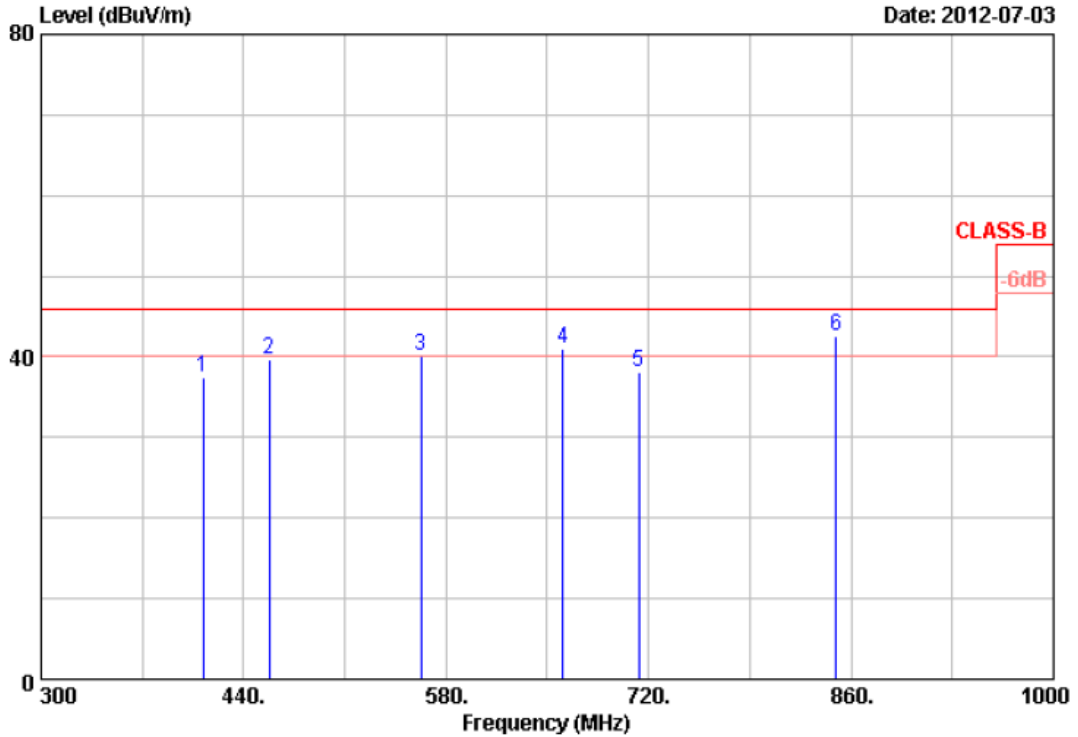

Item	Freq	Read Value	Factor	Result	Limit	Margin	Remark	Ant Pos	Tab Pos
	MHz	dBuV	dB/m	dBuV/m	dBuV/m	dB		cm	Deg
1	412.00	42.93	-5.59	37.34	46.00	-8.66	Peak	100	0
2	457.50	47.53	-7.77	39.76	46.00	-6.24	Peak	100	0
3	562.50	33.32	6.82	40.14	46.00	-5.86	QP	100	0
4	660.50	41.94	-1.03	40.91	46.00	-5.09	Peak	100	0
5	713.00	34.93	3.27	38.20	46.00	-7.80	Peak	100	0
6	849.50	33.09	9.40	42.49	46.00	-3.51	Peak	100	0

Notes:

1. Result = Read Value + Factor
2. Factor = Antenna Factor + Cable Loss - Amplifier
3. The resolution bandwidth of test receiver/spectrum analyzer is 120KHz and video bandwidth is 300kHz for Peak detection and Quasi-peak detection at frequency below 1GHz.
4. All below 1GHz configurations are pretested among available 802.11b/g/n modes and found that the worst cases are on channel 1 of 802.11g & n20 mode and Channel 3 for n40 mode. Only worst case data concluded above were presented in this test report.
5. The data is worse case.



Power	: AC 120V	Pol/Phase	: HORIZONTAL
Test Mode 1	: 802.11g, CH1	Temperature	: 25 °C
Adapter	: DVE \ DSC-6PFA-05 FUS 050100	Humidity	: 67 %

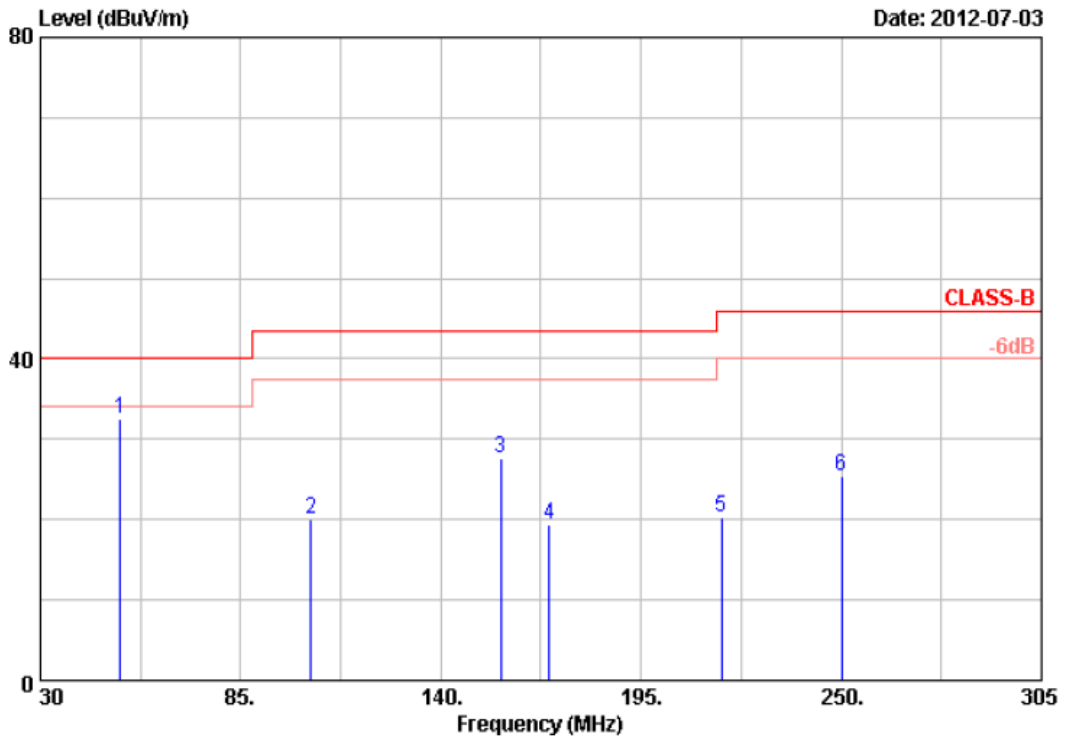

Item	Freq	Read Value	Factor	Result	Limit	Margin	Remark	Ant Pos	Tab Pos
	MHz	dBuV	dB/m	dBuV/m	dBuV/m	dB		cm	Deg
1	52.00	42.57	-10.12	32.45	40.00	-7.55	Peak	100	360
2	104.25	38.87	-18.79	20.08	43.50	-23.42	Peak	100	360
3	156.50	43.86	-16.14	27.72	43.50	-15.78	Peak	100	360
4	169.70	30.65	-11.27	19.38	43.50	-24.12	Peak	100	360
5	217.00	36.49	-16.11	20.38	46.00	-25.62	Peak	100	360
6	250.00	38.87	-13.52	25.35	46.00	-20.65	Peak	100	360

Notes:

1. Result = Read Value + Factor
2. Factor = Antenna Factor + Cable Loss - Amplifier
3. The resolution bandwidth of test receiver/spectrum analyzer is 120KHz and video bandwidth is 300kHz for Peak detection and Quasi-peak detection at frequency below 1GHz.
4. All below 1GHz configurations are pretested among available 802.11b/g/n modes and found that the worst cases are on channel 1 of 802.11g & n20 mode and Channel 3 for n40 mode. Only worst case data concluded above were presented in this test report.
5. The data is worse case.



Power	: AC 120V	Pol/Phase	: HORIZONTAL
Test Mode 1	: 802.11g, CH1	Temperature	: 25 °C
Adapter	: DVE \ DSC-6PFA-05 FUS 050100	Humidity	: 67 %

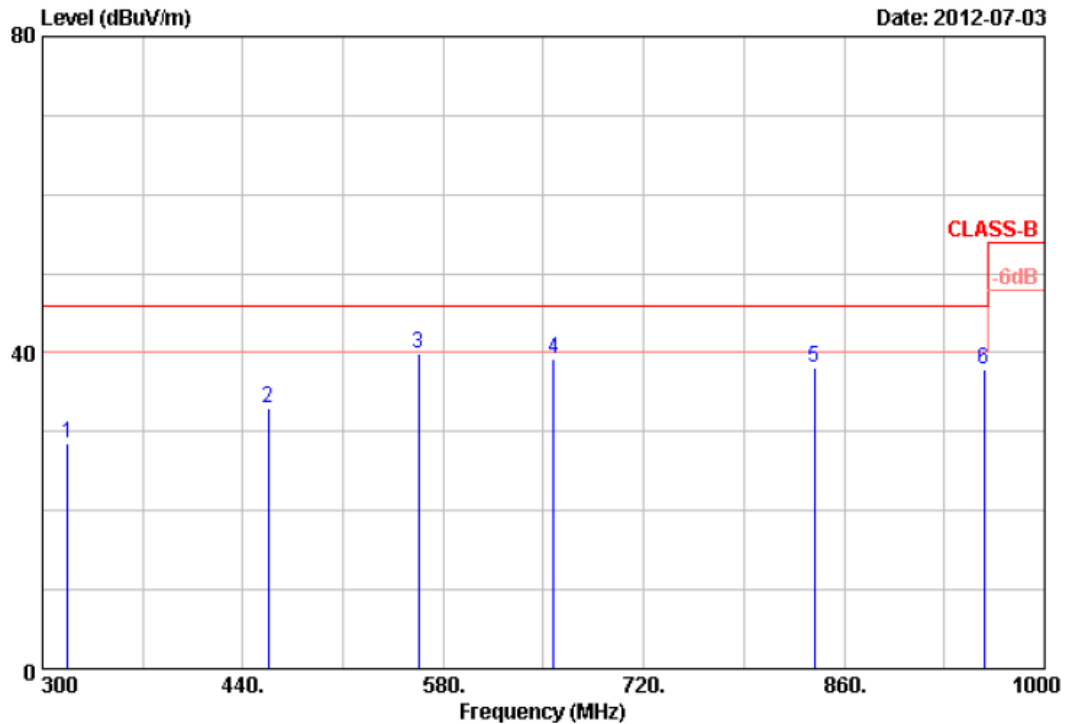

Item	Freq	Read Value	Factor	Result	Limit	Margin	Remark	Ant Pos	Tab Pos
	MHz	dBuV	dB/m	dBuV/m	dBuV/m	dB		cm	Deg
1	317.50	40.68	-12.06	28.62	46.00	-17.38	Peak	100	0
2	457.50	37.89	-4.93	32.96	46.00	-13.04	Peak	100	0
3	562.50	37.93	2.05	39.98	46.00	-6.02	Peak	100	0
4	657.00	39.68	-0.49	39.19	46.00	-6.81	Peak	100	0
5	839.00	29.51	8.66	38.17	46.00	-7.83	Peak	100	0
6	958.00	30.06	7.84	37.90	46.00	-8.10	Peak	100	0

Notes:

1. Result = Read Value + Factor
2. Factor = Antenna Factor + Cable Loss - Amplifier
3. The resolution bandwidth of test receiver/spectrum analyzer is 120KHz and video bandwidth is 300kHz for Peak detection and Quasi-peak detection at frequency below 1GHz.
4. All below 1GHz configurations are pretested among available 802.11b/g/n modes and found that the worst cases are on channel 1 of 802.11g & n20 mode and Channel 3 for n40 mode. Only worst case data concluded above were presented in this test report.
5. The data is worse case.



Power	: AC 120V	Pol/Phase	: VERTICAL
Test Mode 1	: 802.11b, CH1	Temperature	: 25 °C
Adapter	: DVE \ DSC-6PFA-05 FUS 050100	Humidity	: 67 %

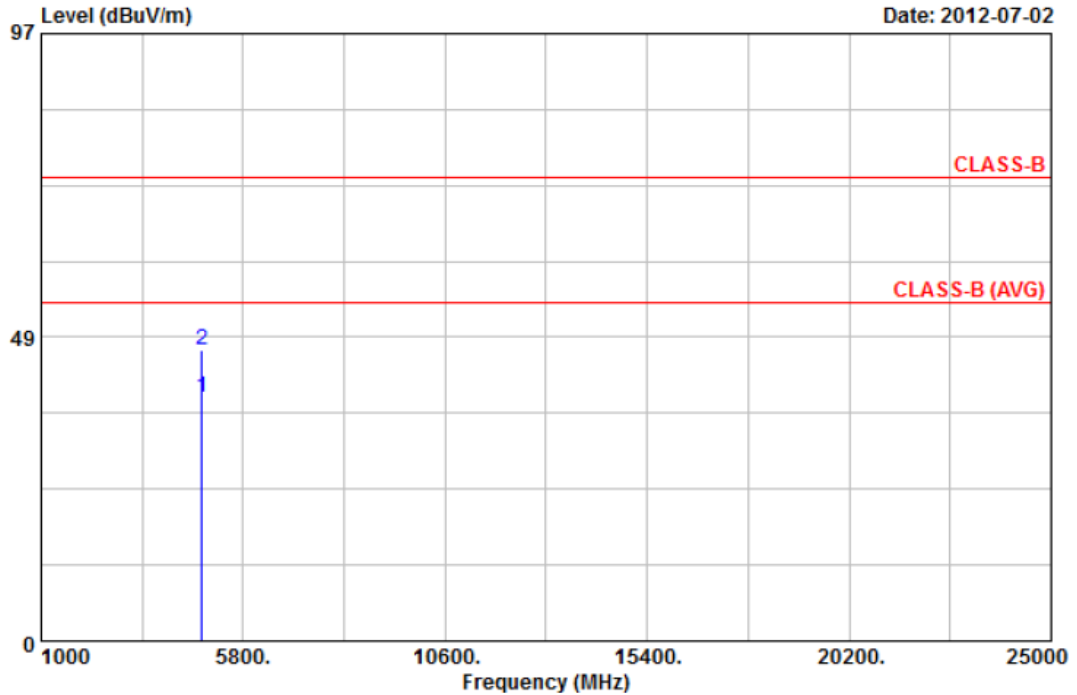

Item	Freq	Read Value	Factor	Result	Limit	Margin	Remark	Ant Pos	Tab Pos
	MHz	dBuV	dB/m	dBuV/m	dBuV/m	dB		cm	Deg
1	4824.00	33.39	5.61	39.00	54.00	-15.00	Average	100	135
2	4824.00	40.78	5.61	46.39	74.00	-27.61	Peak	100	360

Notes:

1. Result = Read Value + Factor
2. Factor = Antenna Factor + Cable Loss - Amplifier
3. The resolution bandwidth of test receiver/spectrum analyzer is 120KHz and video bandwidth is 300kHz for Peak detection and Quasi-peak detection at frequency below 1GHz.
4. The resolution bandwidth of test receiver/spectrum analyzer is 1MHz and video bandwidth is 3MHz for Peak detection at frequency above 1GHz.
5. The resolution bandwidth of test receiver/spectrum analyzer is 1MHz and video bandwidth is 3MHz (detector sample mode) for Average detection at frequency above 1GHz.
6. The other emissions is too low to be measured. (The worst case noise floor measurements value is 47.93 dBuV at 16.10GHz)
7. The data is worse case.



Power	: AC 120V	Pol/Phase	: HORIZONTAL
Test Mode 1	: 802.11b, CH1	Temperature	: 25 °C
Adapter	: DVE \ DSC-6PFA-05 FUS 050100	Humidity	: 67 %

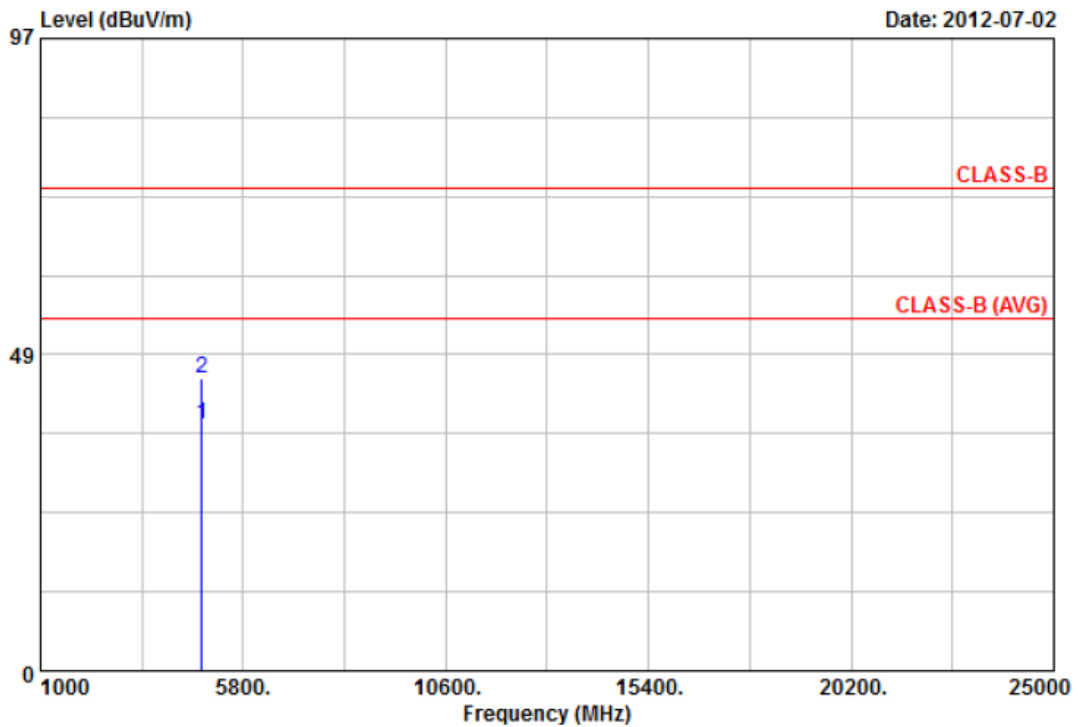

Item	Freq	Read Value	Factor	Result	Limit	Margin	Remark	Ant Pos	Tab Pos
	MHz	dBuV	dB/m	dBuV/m	dBuV/m	dB		cm	Deg
1	4824.00	33.88	3.95	37.83	54.00	-16.17	Average	100	145
2	4824.00	40.98	3.95	44.93	74.00	-29.07	Peak	100	360

Notes:

1. Result = Read Value + Factor
2. Factor = Antenna Factor + Cable Loss - Amplifier
3. The resolution bandwidth of test receiver/spectrum analyzer is 120KHz and video bandwidth is 300kHz for Peak detection and Quasi-peak detection at frequency below 1GHz.
4. The resolution bandwidth of test receiver/spectrum analyzer is 1MHz and video bandwidth is 3MHz for Peak detection at frequency above 1GHz.
5. The resolution bandwidth of test receiver/spectrum analyzer is 1MHz and video bandwidth is 3MHz (detector sample mode) for Average detection at frequency above 1GHz.
6. The other emissions is too low to be measured. (The worst case noise floor measurements value is 47.93 dBuV at 16.10GHz)
7. The data is worse case.



Power	: AC 120V	Pol/Phase	: VERTICAL
Test Mode 1	: 802.11b, CH6	Temperature	: 25 °C
Adapter	: DVE \ DSC-6PFA-05 FUS 050100	Humidity	: 67 %

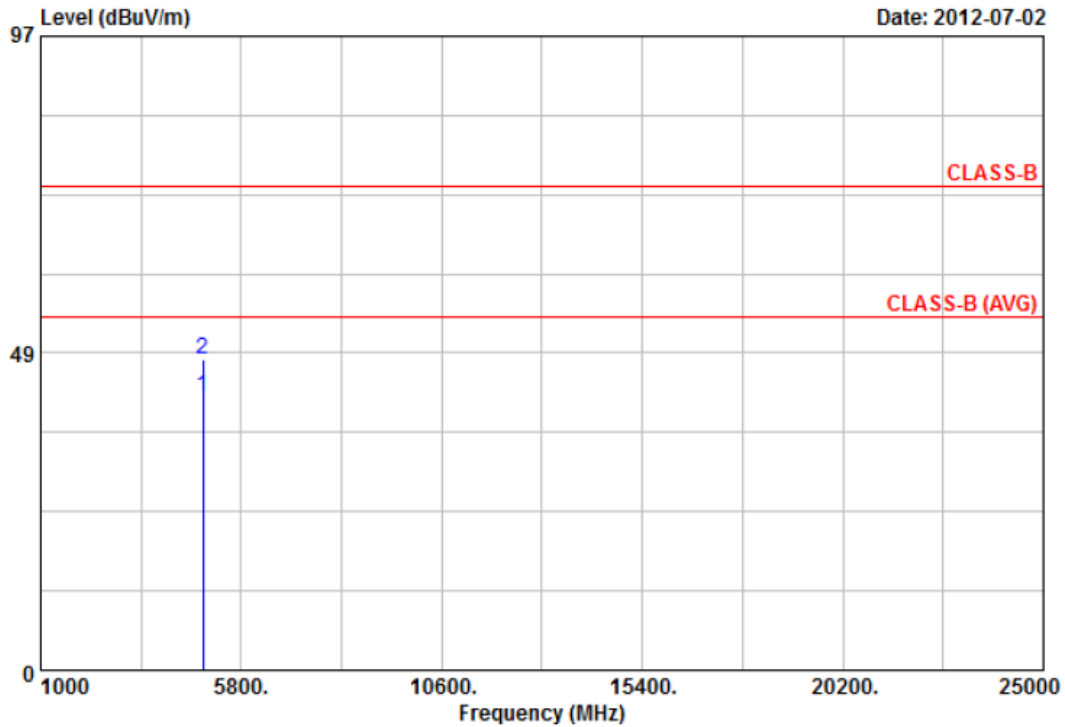

Item	Freq	Read Value	Factor	Result	Limit	Margin	Remark	Ant Pos	Tab Pos
	MHz	dBuV	dB/m	dBuV/m	dBuV/m	dB		cm	Deg
1	4874.00	35.19	6.59	41.78	54.00	-12.22	Average	100	136
2	4874.00	41.03	6.59	47.62	74.00	-26.38	Peak	100	0

Notes:

1. Result = Read Value + Factor
2. Factor = Antenna Factor + Cable Loss - Amplifier
3. The resolution bandwidth of test receiver/spectrum analyzer is 120KHz and video bandwidth is 300kHz for Peak detection and Quasi-peak detection at frequency below 1GHz.
4. The resolution bandwidth of test receiver/spectrum analyzer is 1MHz and video bandwidth is 3MHz for Peak detection at frequency above 1GHz.
5. The resolution bandwidth of test receiver/spectrum analyzer is 1MHz and video bandwidth is 3MHz (detector sample mode) for Average detection at frequency above 1GHz.
6. The other emissions is too low to be measured. (The worst case noise floor measurements value is 47.93 dBuV at 16.10GHz)
7. The data is worse case.





Power	: AC 120V	Pol/Phase	: HORIZONTAL
Test Mode 1	: 802.11b, CH6	Temperature	: 25 °C
Adapter	: DVE \ DSC-6PFA-05 FUS 050100	Humidity	: 67 %

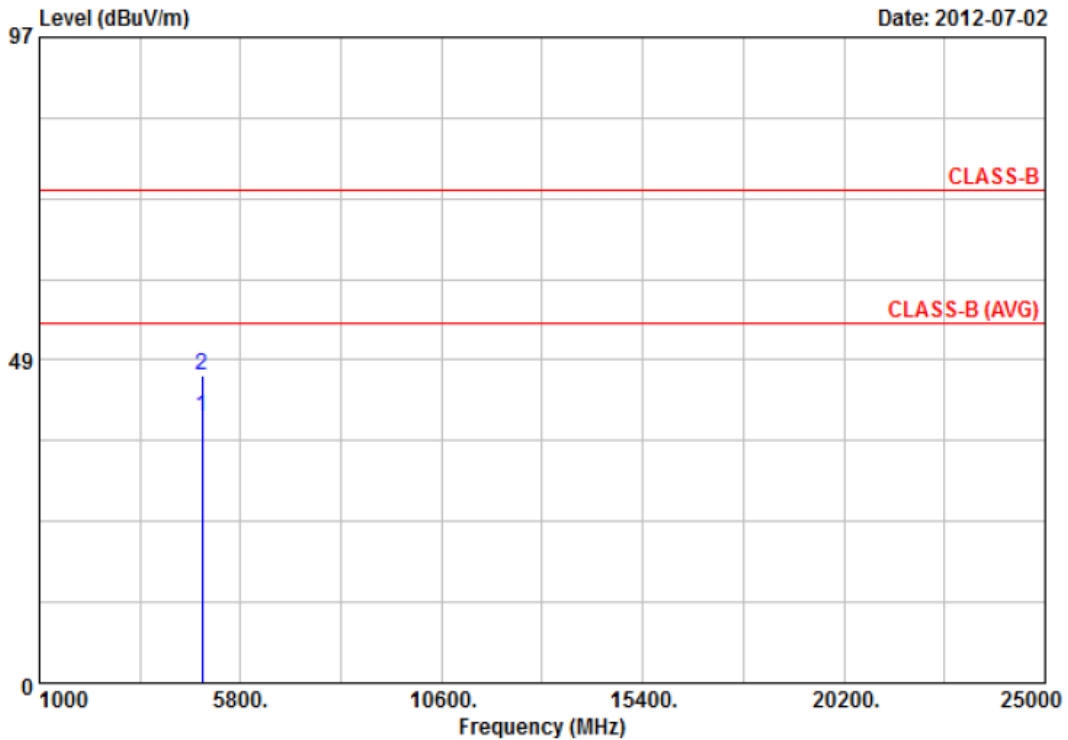

Item	Freq	Read Value	Factor	Result	Limit	Margin	Remark	Ant Pos	Tab Pos
	MHz	dBuV	dB/m	dBuV/m	dBuV/m	dB		cm	Deg
1	4874.00	35.19	4.73	39.92	54.00	-14.08	Average	100	134
2	4874.00	41.48	4.73	46.21	74.00	-27.79	Peak	100	360

Notes:

1. Result = Read Value + Factor
2. Factor = Antenna Factor + Cable Loss - Amplifier
3. The resolution bandwidth of test receiver/spectrum analyzer is 120KHz and video bandwidth is 300kHz for Peak detection and Quasi-peak detection at frequency below 1GHz.
4. The resolution bandwidth of test receiver/spectrum analyzer is 1MHz and video bandwidth is 3MHz for Peak detection at frequency above 1GHz.
5. The resolution bandwidth of test receiver/spectrum analyzer is 1MHz and video bandwidth is 3MHz (detector sample mode) for Average detection at frequency above 1GHz.
6. The other emissions is too low to be measured. (The worst case noise floor measurements value is 47.93 dBuV at 16.10GHz)
7. The data is worse case.



Power	: AC 120V	Pol/Phase	: VERTICAL
Test Mode 1	: 802.11b, CH11	Temperature	: 25 °C
Adapter	: DVE \ DSC-6PFA-05 FUS 050100	Humidity	: 67 %

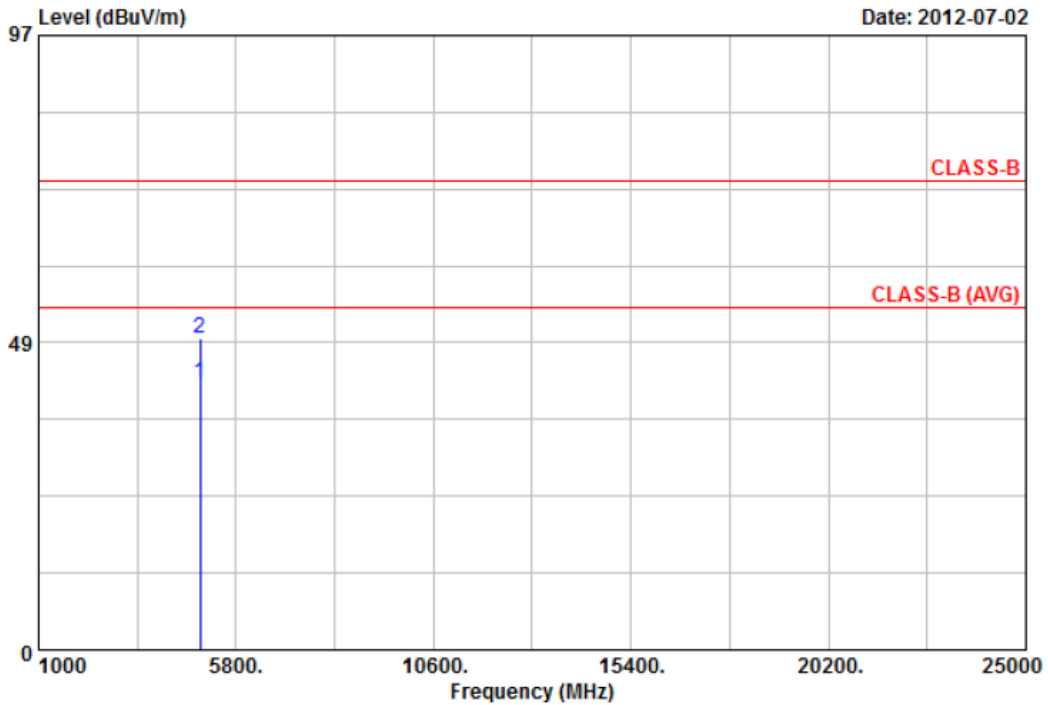

Item	Freq	Read Value	Factor	Result	Limit	Margin	Remark	Ant Pos	Tab Pos
	MHz	dBuV	dB/m	dBuV/m	dBuV/m	dB		cm	Deg
1	4924.00	34.87	7.16	42.03	54.00	-11.97	Average	100	129
2	4924.00	41.99	7.16	49.15	74.00	-24.85	Peak	100	360

Notes:

1. Result = Read Value + Factor
2. Factor = Antenna Factor + Cable Loss - Amplifier
3. The resolution bandwidth of test receiver/spectrum analyzer is 120KHz and video bandwidth is 300kHz for Peak detection and Quasi-peak detection at frequency below 1GHz.
4. The resolution bandwidth of test receiver/spectrum analyzer is 1MHz and video bandwidth is 3MHz for Peak detection at frequency above 1GHz.
5. The resolution bandwidth of test receiver/spectrum analyzer is 1MHz and video bandwidth is 3MHz (detector sample mode) for Average detection at frequency above 1GHz.
6. The other emissions is too low to be measured. (The worst case noise floor measurements value is 47.93 dBuV at 16.10GHz)
7. The data is worse case.



Power	: AC 120V	Pol/Phase	: HORIZONTAL
Test Mode 1	: 802.11b, CH11	Temperature	: 25 °C
Adapter	: DVE \ DSC-6PFA-05 FUS 050100	Humidity	: 67 %

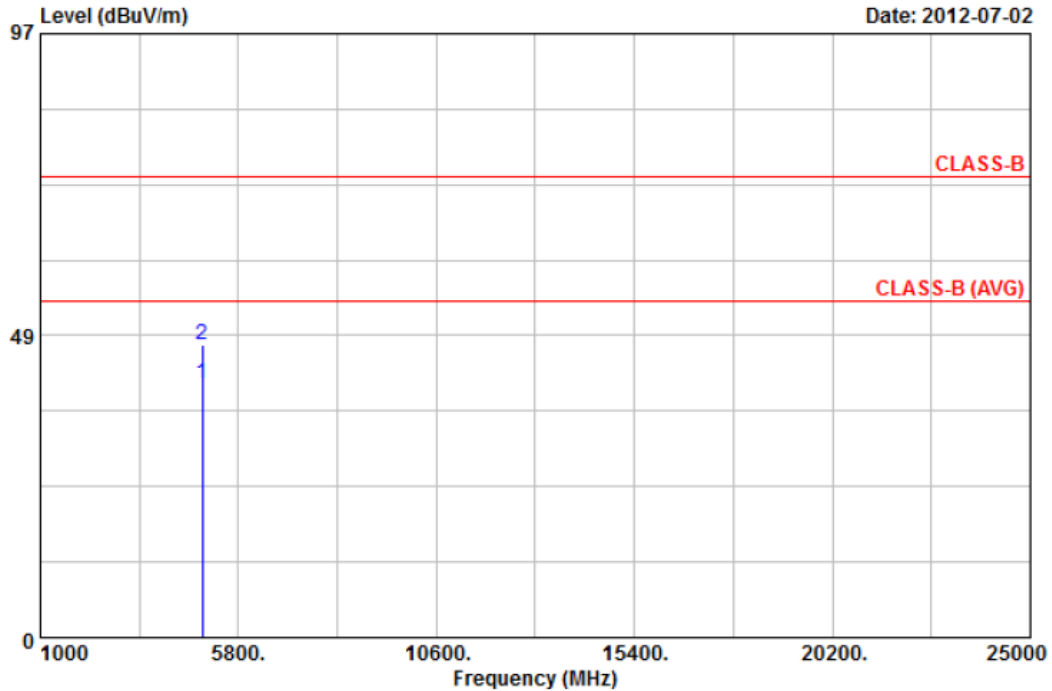

Item	Freq	Read Value	Factor	Result	Limit	Margin	Remark	Ant Pos	Tab Pos
	MHz	dBuV	dB/m	dBuV/m	dBuV/m	dB		cm	Deg
1	4924.00	35.74	5.15	40.89	54.00	-13.11	Average	100	134
2	4924.00	41.78	5.15	46.93	74.00	-27.07	Peak	100	360

Notes:

1. Result = Read Value + Factor
2. Factor = Antenna Factor + Cable Loss - Amplifier
3. The resolution bandwidth of test receiver/spectrum analyzer is 120KHz and video bandwidth is 300kHz for Peak detection and Quasi-peak detection at frequency below 1GHz.
4. The resolution bandwidth of test receiver/spectrum analyzer is 1MHz and video bandwidth is 3MHz for Peak detection at frequency above 1GHz.
5. The resolution bandwidth of test receiver/spectrum analyzer is 1MHz and video bandwidth is 3MHz (detector sample mode) for Average detection at frequency above 1GHz.
6. The other emissions is too low to be measured. (The worst case noise floor measurements value is 47.93 dBuV at 16.10GHz)
7. The data is worse case.



Power	: AC 120V	Pol/Phase	: VERTICAL
Test Mode 1	: 802.11g, CH1	Temperature	: 25 °C
Adapter	: DVE \ DSC-6PFA-05 FUS 050100	Humidity	: 67 %

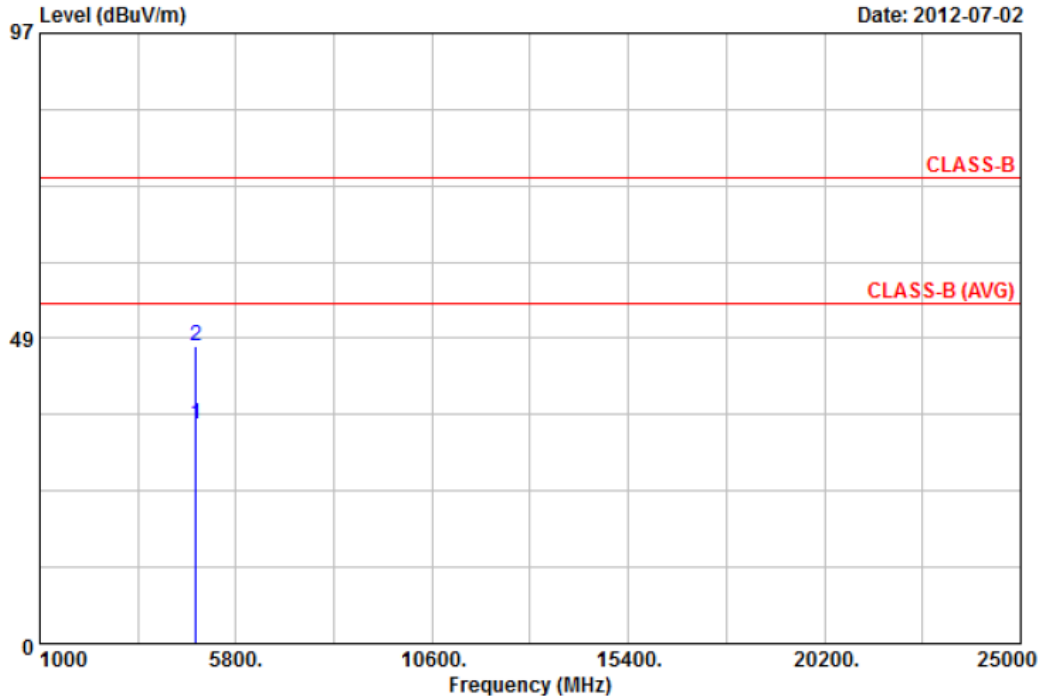

Item	Freq	Read Value	Factor	Result	Limit	Margin	Remark	Ant Pos	Tab Pos
	MHz	dBuV	dB/m	dBuV/m	dBuV/m	dB		cm	Deg
1	4824.00	29.24	5.61	34.85	54.00	-19.15	Average	100	360
2	4824.00	41.68	5.61	47.29	74.00	-26.71	Peak	100	360

Notes:

1. Result = Read Value + Factor
2. Factor = Antenna Factor + Cable Loss - Amplifier
3. The resolution bandwidth of test receiver/spectrum analyzer is 120KHz and video bandwidth is 300kHz for Peak detection and Quasi-peak detection at frequency below 1GHz.
4. The resolution bandwidth of test receiver/spectrum analyzer is 1MHz and video bandwidth is 3MHz for Peak detection at frequency above 1GHz.
5. The resolution bandwidth of test receiver/spectrum analyzer is 1MHz and video bandwidth is 3MHz (detector sample mode) for Average detection at frequency above 1GHz.
6. The other emissions is too low to be measured. (The worst case noise floor measurements value is 47.93 dBuV at 16.10GHz)
7. The data is worse case.



Power	: AC 120V	Pol/Phase	: HORIZONTAL
Test Mode 1	: 802.11g, CH1	Temperature	: 25 °C
Adapter	: DVE \ DSC-6PFA-05 FUS 050100	Humidity	: 67 %

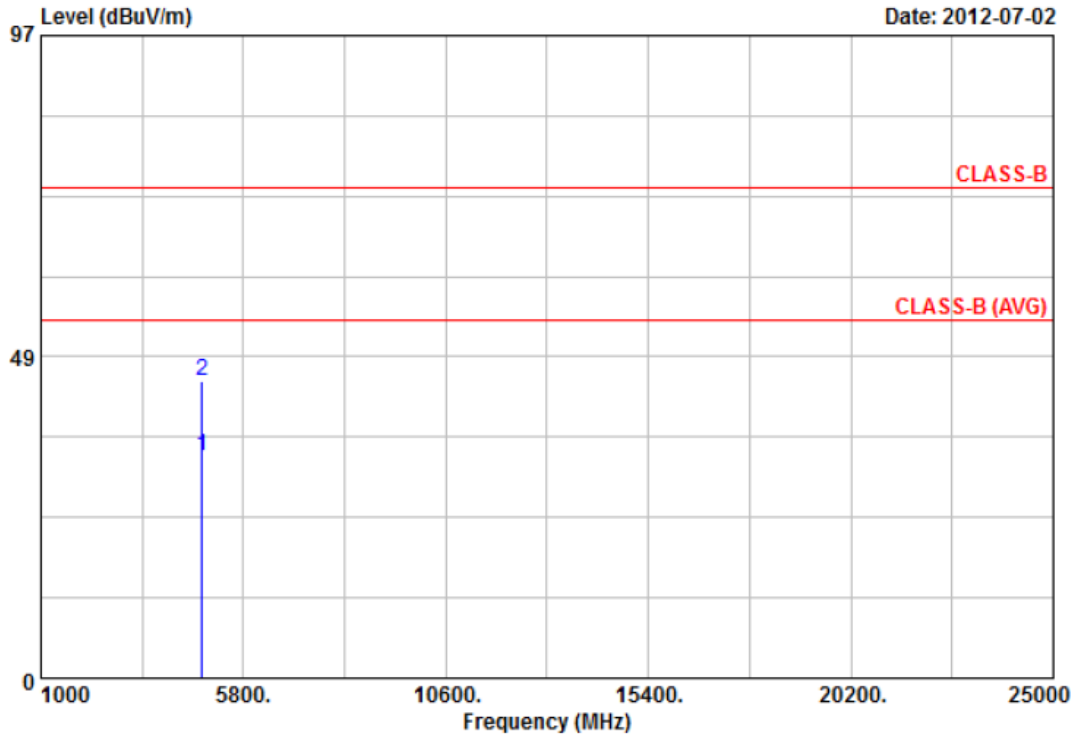

Item	Freq	Read Value	Factor	Result	Limit	Margin	Remark	Ant Pos	Tab Pos
	MHz	dBuV	dB/m	dBuV/m	dBuV/m	dB		cm	Deg
1	4824.00	29.48	3.95	33.43	54.00	-20.57	Average	100	360
2	4824.00	41.03	3.95	44.98	74.00	-29.02	Peak	100	360

Notes:

1. Result = Read Value + Factor
2. Factor = Antenna Factor + Cable Loss - Amplifier
3. The resolution bandwidth of test receiver/spectrum analyzer is 120KHz and video bandwidth is 300kHz for Peak detection and Quasi-peak detection at frequency below 1GHz.
4. The resolution bandwidth of test receiver/spectrum analyzer is 1MHz and video bandwidth is 3MHz for Peak detection at frequency above 1GHz.
5. The resolution bandwidth of test receiver/spectrum analyzer is 1MHz and video bandwidth is 3MHz (detector sample mode) for Average detection at frequency above 1GHz.
6. The other emissions is too low to be measured. (The worst case noise floor measurements value is 47.93 dBuV at 16.10GHz)
7. The data is worse case.



Power	: AC 120V	Pol/Phase	: VERTICAL
Test Mode 1	: 802.11g, CH6	Temperature	: 25 °C
Adapter	: DVE \ DSC-6PFA-05 FUS 050100	Humidity	: 67 %

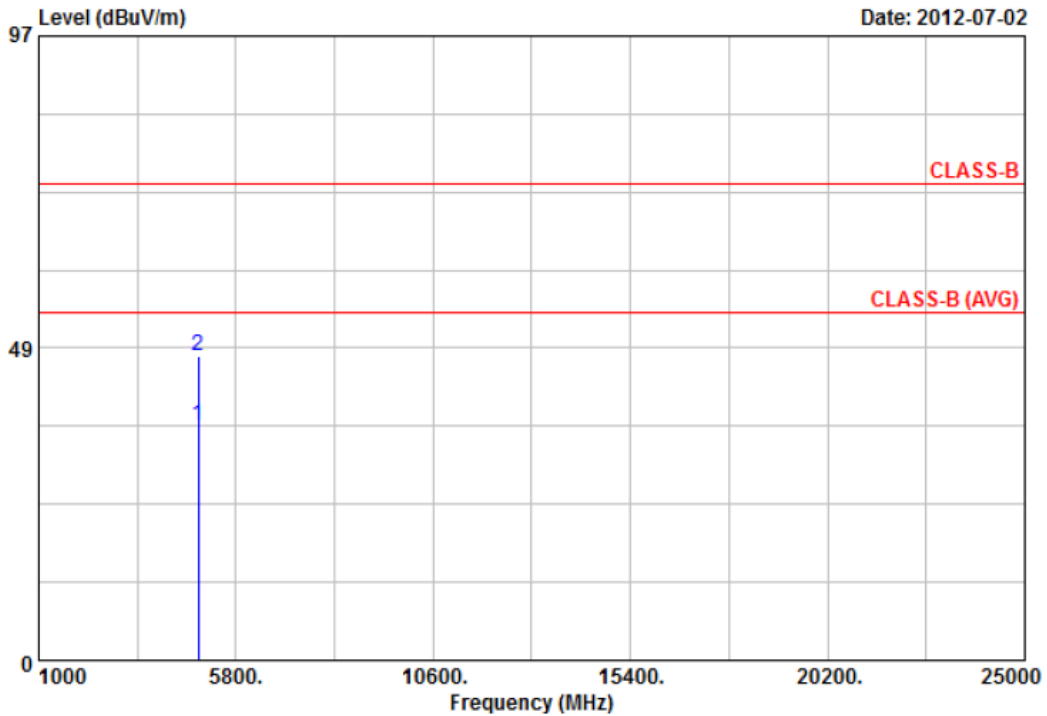

Item	Freq	Read Value	Factor	Result	Limit	Margin	Remark	Ant Pos	Tab Pos
	MHz	dBuV	dB/m	dBuV/m	dBuV/m	dB		cm	Deg
1	4874.00	29.78	6.59	36.37	54.00	-17.63	Average	100	360
2	4874.00	40.67	6.59	47.26	74.00	-26.74	Peak	100	360

Notes:

1. Result = Read Value + Factor
2. Factor = Antenna Factor + Cable Loss - Amplifier
3. The resolution bandwidth of test receiver/spectrum analyzer is 120KHz and video bandwidth is 300kHz for Peak detection and Quasi-peak detection at frequency below 1GHz.
4. The resolution bandwidth of test receiver/spectrum analyzer is 1MHz and video bandwidth is 3MHz for Peak detection at frequency above 1GHz.
5. The resolution bandwidth of test receiver/spectrum analyzer is 1MHz and video bandwidth is 3MHz (detector sample mode) for Average detection at frequency above 1GHz.
6. The other emissions is too low to be measured. (The worst case noise floor measurements value is 47.93 dBuV at 16.10GHz)
7. The data is worse case.



Power	: AC 120V	Pol/Phase	: HORIZONTAL
Test Mode 1	: 802.11g, CH6	Temperature	: 25 °C
Adapter	: DVE \ DSC-6PFA-05 FUS 050100	Humidity	: 67 %

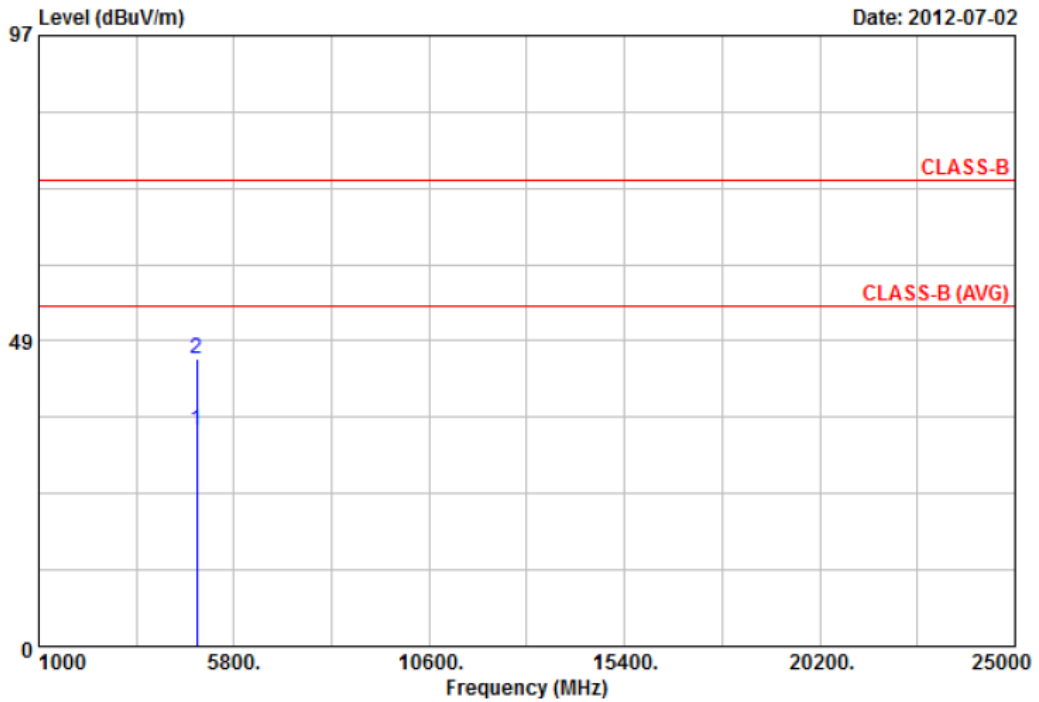

Item	Freq	Read Value	Factor	Result	Limit	Margin	Remark	Ant Pos	Tab Pos
	MHz	dBuV	dB/m	dBuV/m	dBuV/m	dB		cm	Deg
1	4874.00	29.46	4.73	34.19	54.00	-19.81	Average	100	360
2	4874.00	41.06	4.73	45.79	74.00	-28.21	Peak	100	360

Notes:

1. Result = Read Value + Factor
2. Factor = Antenna Factor + Cable Loss - Amplifier
3. The resolution bandwidth of test receiver/spectrum analyzer is 120KHz and video bandwidth is 300kHz for Peak detection and Quasi-peak detection at frequency below 1GHz.
4. The resolution bandwidth of test receiver/spectrum analyzer is 1MHz and video bandwidth is 3MHz for Peak detection at frequency above 1GHz.
5. The resolution bandwidth of test receiver/spectrum analyzer is 1MHz and video bandwidth is 3MHz (detector sample mode) for Average detection at frequency above 1GHz.
6. The other emissions is too low to be measured. (The worst case noise floor measurements value is 47.93 dBuV at 16.10GHz)
7. The data is worse case.



Power	: AC 120V	Pol/Phase	: VERTICAL
Test Mode 1	: 802.11g, CH11	Temperature	: 25 °C
Adapter	: DVE \ DSC-6PFA-05 FUS 050100	Humidity	: 67 %

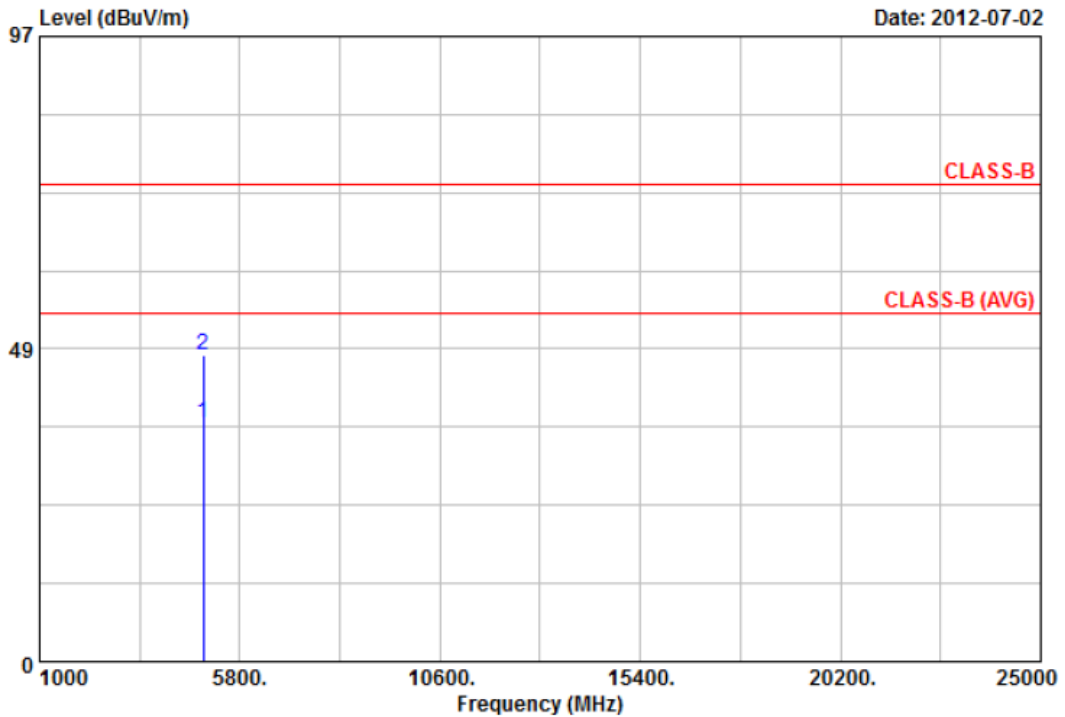

Item	Freq	Read Value	Factor	Result	Limit	Margin	Remark	Ant Pos	Tab Pos
	MHz	dBuV	dB/m	dBuV/m	dBuV/m	dB		cm	Deg
1	4924.00	29.73	7.16	36.89	54.00	-17.11	Average	100	0
2	4924.00	40.51	7.16	47.67	74.00	-26.33	Peak	100	0

Notes:

1. Result = Read Value + Factor
2. Factor = Antenna Factor + Cable Loss - Amplifier
3. The resolution bandwidth of test receiver/spectrum analyzer is 120KHz and video bandwidth is 300kHz for Peak detection and Quasi-peak detection at frequency below 1GHz.
4. The resolution bandwidth of test receiver/spectrum analyzer is 1MHz and video bandwidth is 3MHz for Peak detection at frequency above 1GHz.
5. The resolution bandwidth of test receiver/spectrum analyzer is 1MHz and video bandwidth is 3MHz (detector sample mode) for Average detection at frequency above 1GHz.
6. The other emissions is too low to be measured. (The worst case noise floor measurements value is 47.93 dBuV at 16.10GHz)
7. The data is worse case.





Power	: AC 120V	Pol/Phase	: HORIZONTAL
Test Mode 1	: 802.11g, CH11	Temperature	: 25 °C
Adapter	: DVE \ DSC-6PFA-05 FUS 050100	Humidity	: 67 %

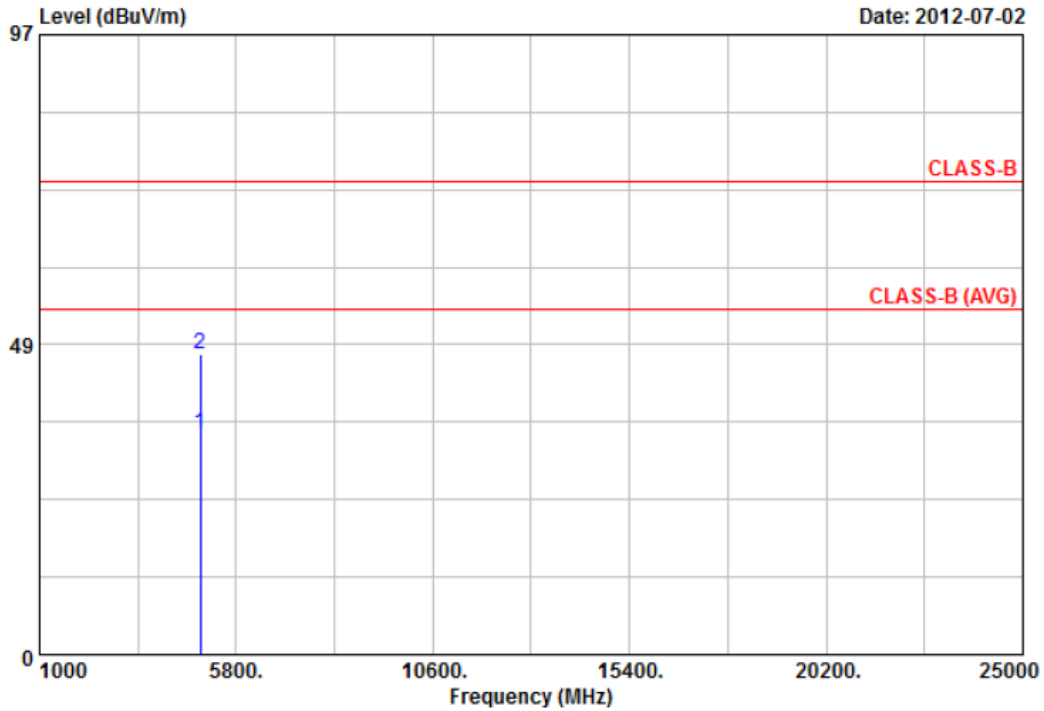

Item	Freq	Read Value	Factor	Result	Limit	Margin	Remark	Ant Pos	Tab Pos
	MHz	dBuV	dB/m	dBuV/m	dBuV/m	dB		cm	Deg
1	4924.00	29.46	5.15	34.61	54.00	-19.39	Average	100	360
2	4924.00	41.78	5.15	46.93	74.00	-27.07	Peak	100	360

Notes:

1. Result = Read Value + Factor
2. Factor = Antenna Factor + Cable Loss - Amplifier
3. The resolution bandwidth of test receiver/spectrum analyzer is 120KHz and video bandwidth is 300kHz for Peak detection and Quasi-peak detection at frequency below 1GHz.
4. The resolution bandwidth of test receiver/spectrum analyzer is 1MHz and video bandwidth is 3MHz for Peak detection at frequency above 1GHz.
5. The resolution bandwidth of test receiver/spectrum analyzer is 1MHz and video bandwidth is 3MHz (detector sample mode) for Average detection at frequency above 1GHz.
6. The other emissions is too low to be measured. (The worst case noise floor measurements value is 47.93 dBuV at 16.10GHz)
7. The data is worse case.



Power	: AC 120V	Pol/Phase	: VERTICAL
Test Mode 1	: 802.11n HT20, CH1	Temperature	: 25 °C
Adapter	: DVE \ DSC-6PFA-05 FUS 050100	Humidity	: 67 %

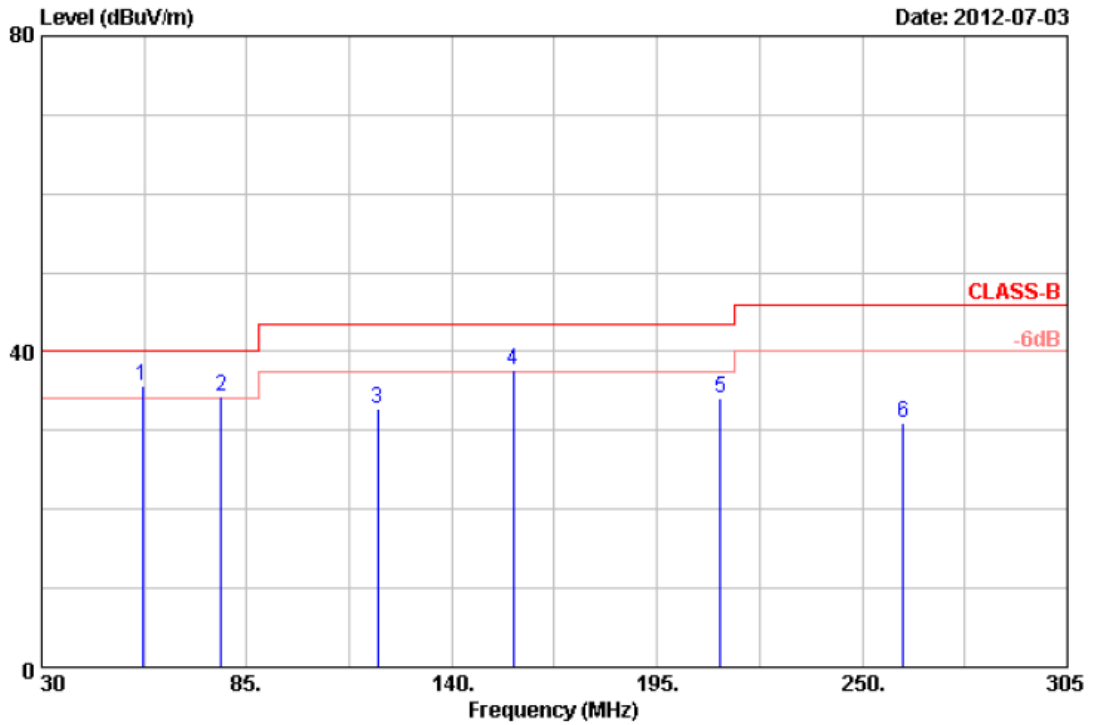

Item	Freq MHz	Read Value dBuV	Factor dB/m	Result dBuV/m	Limit dBuV/m	Margin dB	Remark	Ant Pos cm	Tab Pos Deg
1	56.95	47.46	-11.85	35.61	40.00	-4.39	QP	100	360
2	78.13	42.84	-8.42	34.42	40.00	-5.58	QP	100	360
3	120.20	37.50	-4.66	32.84	43.50	-10.66	Peak	100	360
4	156.50	49.94	-12.27	37.67	43.50	-5.83	Peak	100	360
5	212.05	43.41	-9.22	34.19	43.50	-9.31	Peak	100	360
6	261.00	38.59	-7.66	30.93	46.00	-15.07	Peak	100	360

Notes:

1. Result = Read Value + Factor
2. Factor = Antenna Factor + Cable Loss - Amplifier
3. The resolution bandwidth of test receiver/spectrum analyzer is 120KHz and video bandwidth is 300kHz for Peak detection and Quasi-peak detection at frequency below 1GHz.
4. All below 1GHz configurations are pretested among available 802.11b/g/n modes and found that the worst cases are on channel 1 of 802.11g & n20 mode and Channel 3 for n40 mode. Only worst case data concluded above were presented in this test report.
5. The data is worse case.



Power	: AC 120V	Pol/Phase	: VERTICAL
Test Mode 1	: 802.11n HT20, CH1	Temperature	: 25 °C
Adapter	: DVE \ DSC-6PFA-05 FUS 050100	Humidity	: 67 %

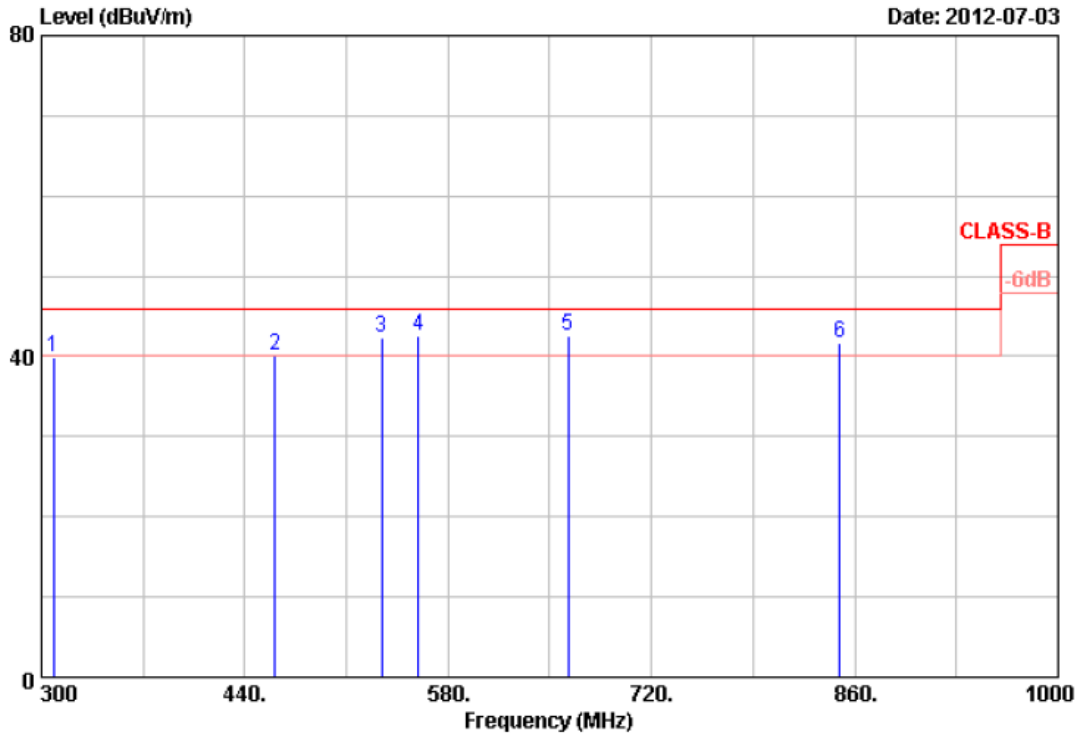

Item	Freq	Read Value	Factor	Result	Limit	Margin	Remark	Ant Pos	Tab Pos
	MHz	dBuV	dB/m	dBuV/m	dBuV/m	dB		cm	Deg
1	308.40	48.69	-8.88	39.81	46.00	-6.19	Peak	100	0
2	461.00	47.56	-7.36	40.20	46.00	-5.80	Peak	100	0
3	534.50	39.08	3.30	42.38	46.00	-3.62	Peak	100	0
4	559.70	35.35	7.13	42.48	46.00	-3.52	Peak	100	0
5	662.60	43.62	-1.14	42.48	46.00	-3.52	Peak	100	0
6	849.50	32.20	9.40	41.60	46.00	-4.40	Peak	100	0

Notes:

1. Result = Read Value + Factor
2. Factor = Antenna Factor + Cable Loss - Amplifier
3. The resolution bandwidth of test receiver/spectrum analyzer is 120KHz and video bandwidth is 300kHz for Peak detection and Quasi-peak detection at frequency below 1GHz.
4. All below 1GHz configurations are pretested among available 802.11b/g/n modes and found that the worst cases are on channel 1 of 802.11g & n20 mode and Channel 3 for n40 mode. Only worst case data concluded above were presented in this test report.
5. The data is worse case.



Power	: AC 120V	Pol/Phase	: HORIZONTAL
Test Mode 1	: 802.11n HT20, CH1	Temperature	: 25 °C
Adapter	: DVE \ DSC-6PFA-05 FUS 050100	Humidity	: 67 %

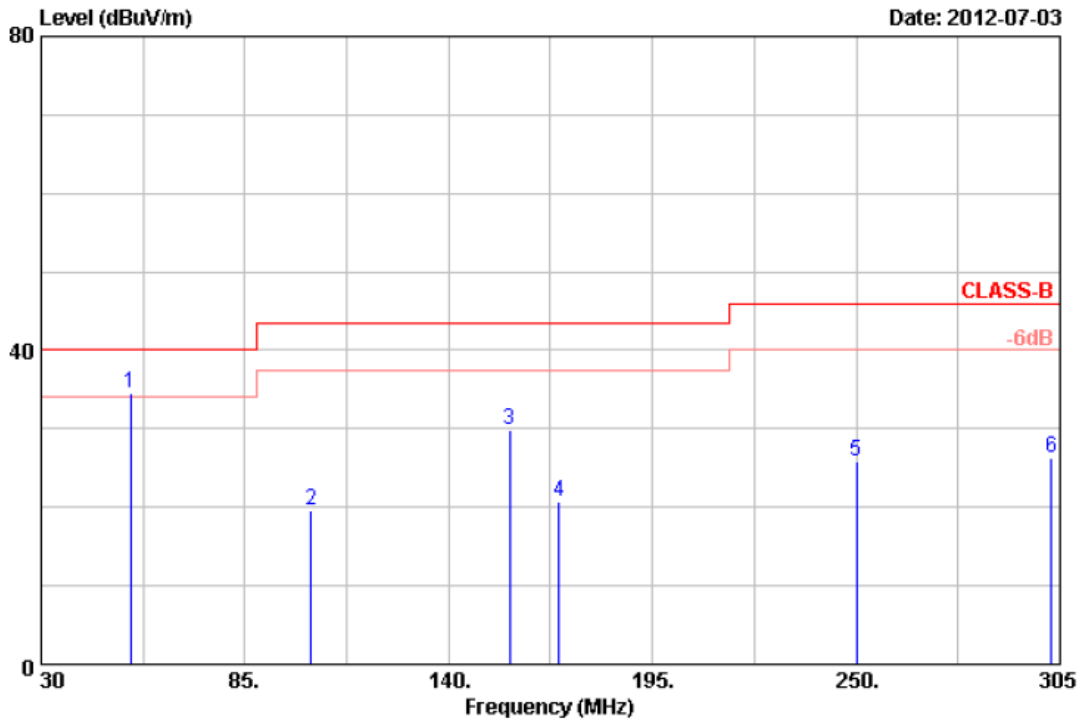

Item	Freq	Read Value	Factor	Result	Limit	Margin	Remark	Ant Pos	Tab Pos
	MHz	dBuV	dB/m	dBuV/m	dBuV/m	dB		cm	Deg
1	54.20	45.90	-11.30	34.60	40.00	-5.40	QP	100	360
2	102.88	38.46	-18.75	19.71	43.50	-23.79	Peak	100	360
3	156.50	45.93	-16.14	29.79	43.50	-13.71	Peak	100	360
4	169.70	32.06	-11.27	20.79	43.50	-22.71	Peak	100	360
5	250.00	39.29	-13.52	25.77	46.00	-20.23	Peak	100	360
6	302.80	38.50	-12.12	26.38	46.00	-19.62	Peak	100	360

Notes:

1. Result = Read Value + Factor
2. Factor = Antenna Factor + Cable Loss - Amplifier
3. The resolution bandwidth of test receiver/spectrum analyzer is 120KHz and video bandwidth is 300kHz for Peak detection and Quasi-peak detection at frequency below 1GHz.
4. All below 1GHz configurations are pretested among available 802.11b/g/n modes and found that the worst cases are on channel 1 of 802.11g & n20 mode and Channel 3 for n40 mode. Only worst case data concluded above were presented in this test report.
5. The data is worse case.



Power	: AC 120V	Pol/Phase	: HORIZONTAL
Test Mode 1	: 802.11n HT20, CH1	Temperature	: 25 °C
Adapter	: DVE \ DSC-6PFA-05 FUS 050100	Humidity	: 67 %

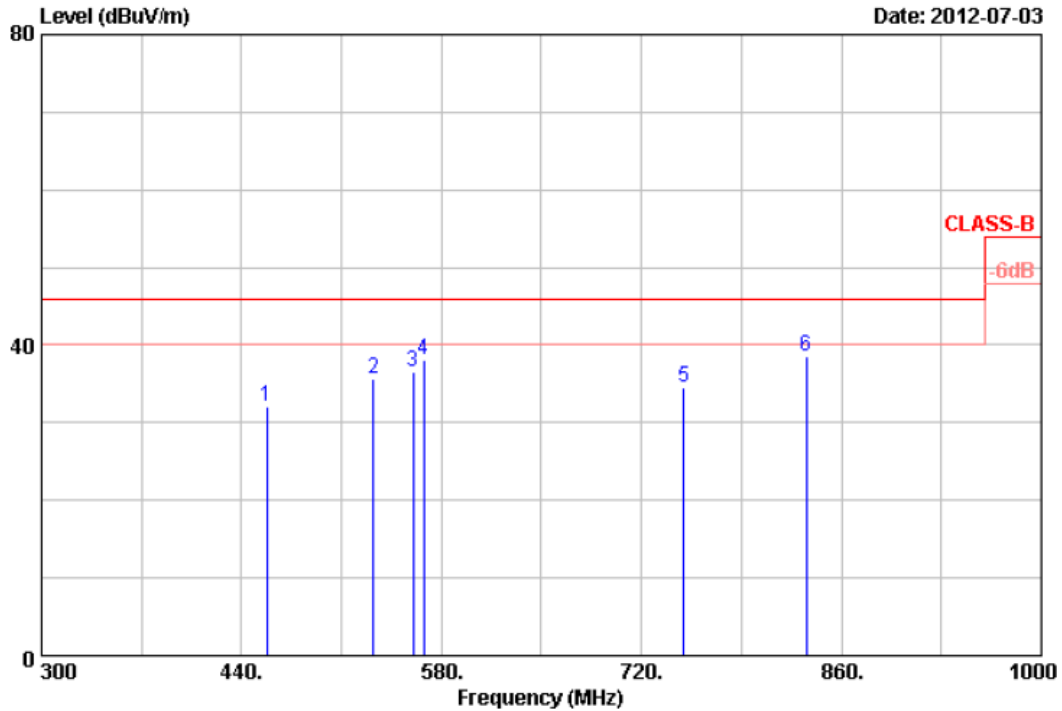

Item	Freq	Read Value	Factor	Result	Limit	Margin	Remark	Ant Pos	Tab Pos
	MHz	dBuV	dB/m	dBuV/m	dBuV/m	dB		cm	Deg
1	457.50	37.07	-4.93	32.14	46.00	-13.86	Peak	100	0
2	532.40	33.74	2.00	35.74	46.00	-10.26	Peak	100	0
3	560.40	34.46	1.98	36.44	46.00	-9.56	Peak	100	0
4	567.40	35.24	2.78	38.02	46.00	-7.98	Peak	100	0
5	749.40	31.96	2.67	34.63	46.00	-11.37	Peak	100	0
6	835.50	29.77	8.89	38.66	46.00	-7.34	Peak	100	0

Notes:

1. Result = Read Value + Factor
2. Factor = Antenna Factor + Cable Loss - Amplifier
3. The resolution bandwidth of test receiver/spectrum analyzer is 120KHz and video bandwidth is 300kHz for Peak detection and Quasi-peak detection at frequency below 1GHz.
4. All below 1GHz configurations are pretested among available 802.11b/g/n modes and found that the worst cases are on channel 1 of 802.11g & n20 mode and Channel 3 for n40 mode. Only worst case data concluded above were presented in this test report.
5. The data is worse case.



Power	: AC 120V	Pol/Phase	: VERTICAL
Test Mode 1	: 802.11n HT20, CH1	Temperature	: 25 °C
Adapter	: DVE \ DSC-6PFA-05 FUS 050100	Humidity	: 67 %

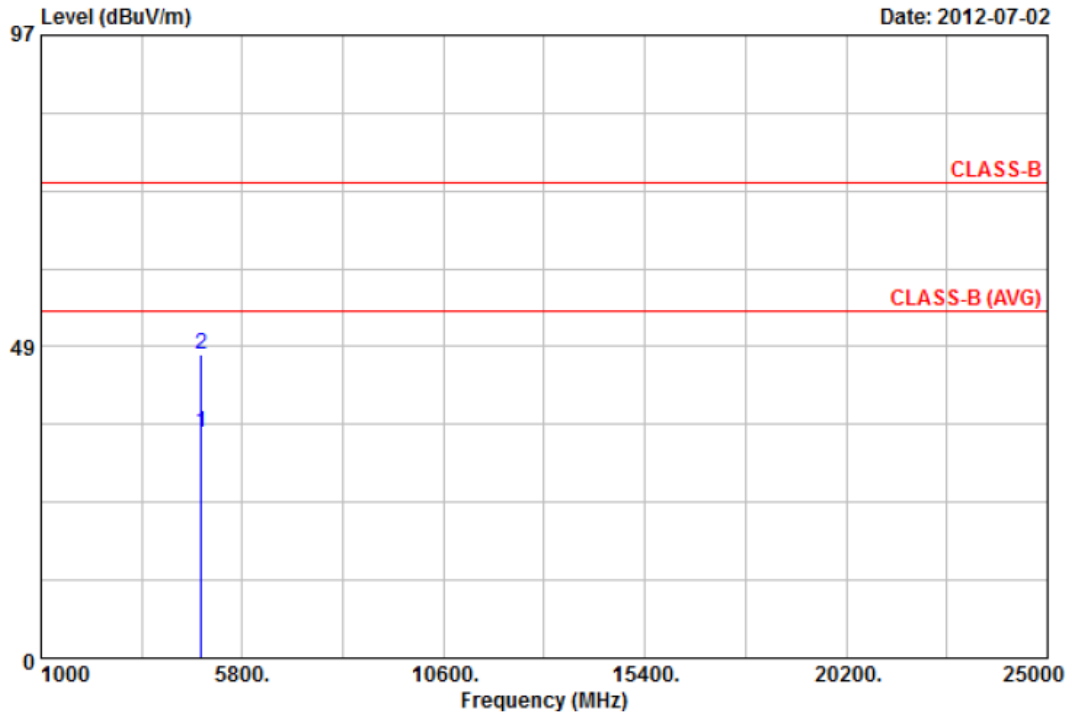

Item	Freq	Read Value	Factor	Result	Limit	Margin	Remark	Ant Pos	Tab Pos
	MHz	dBuV	dB/m	dBuV/m	dBuV/m	dB		cm	Deg
1	4824.00	29.61	5.61	35.22	54.00	-18.78	Average	100	360
2	4824.00	41.58	5.61	47.19	74.00	-26.81	Peak	100	360

Notes:

1. Result = Read Value + Factor
2. Factor = Antenna Factor + Cable Loss - Amplifier
3. The resolution bandwidth of test receiver/spectrum analyzer is 120KHz and video bandwidth is 300kHz for Peak detection and Quasi-peak detection at frequency below 1GHz.
4. The resolution bandwidth of test receiver/spectrum analyzer is 1MHz and video bandwidth is 3MHz for Peak detection at frequency above 1GHz.
5. The resolution bandwidth of test receiver/spectrum analyzer is 1MHz and video bandwidth is 3MHz (detector sample mode) for Average detection at frequency above 1GHz.
6. The other emissions is too low to be measured. (The worst case noise floor measurements value is 47.93 dBuV at 16.10GHz)
7. The data is worse case.



Power	: AC 120V	Pol/Phase	: HORIZONTAL
Test Mode 1	: 802.11n HT20, CH1	Temperature	: 25 °C
Adapter	: DVE \ DSC-6PFA-05 FUS 050100	Humidity	: 67 %

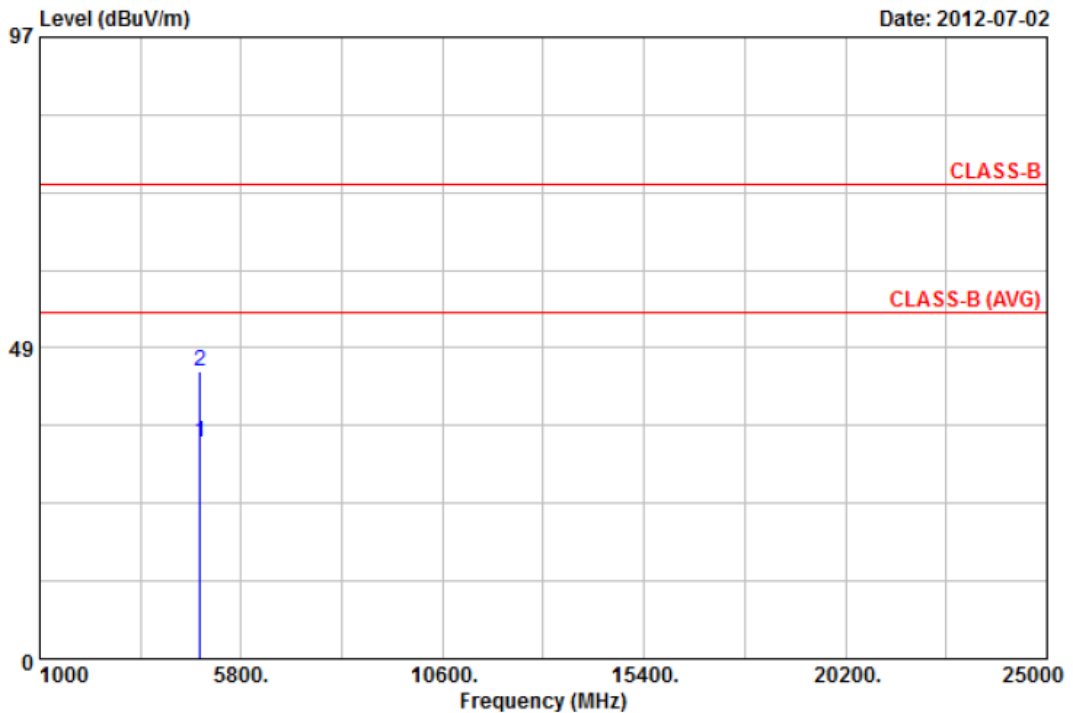

Item	Freq	Read Value	Factor	Result	Limit	Margin	Remark	Ant Pos	Tab Pos
	MHz	dBuV	dB/m	dBuV/m	dBuV/m	dB		cm	Deg
1	4824.00	29.77	3.95	33.72	54.00	-20.28	Average	100	0
2	4824.00	40.86	3.95	44.81	74.00	-29.19	Peak	100	0

Notes:

1. Result = Read Value + Factor
2. Factor = Antenna Factor + Cable Loss - Amplifier
3. The resolution bandwidth of test receiver/spectrum analyzer is 120KHz and video bandwidth is 300KHz for Peak detection and Quasi-peak detection at frequency below 1GHz.
4. The resolution bandwidth of test receiver/spectrum analyzer is 1MHz and video bandwidth is 3MHz for Peak detection at frequency above 1GHz.
5. The resolution bandwidth of test receiver/spectrum analyzer is 1MHz and video bandwidth is 3MHz (detector sample mode) for Average detection at frequency above 1GHz.
6. The other emissions is too low to be measured. (The worst case noise floor measurements value is 47.93 dBuV at 16.10GHz)
7. The data is worse case.



Power	: AC 120V	Pol/Phase	: VERTICAL
Test Mode 1	: 802.11n HT20, CH6	Temperature	: 25 °C
Adapter	: DVE \ DSC-6PFA-05 FUS 050100	Humidity	: 67 %

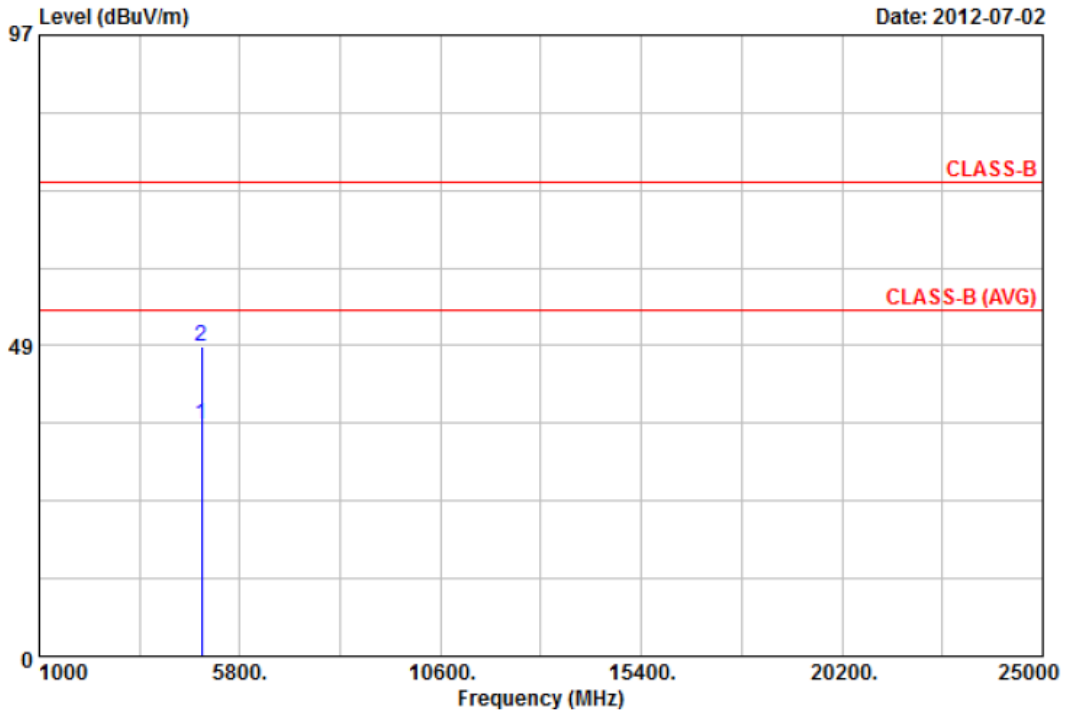

Item	Freq	Read Value	Factor	Result	Limit	Margin	Remark	Ant Pos	Tab Pos
	MHz	dBuV	dB/m	dBuV/m	dBuV/m	dB		cm	Deg
1	4874.00	29.67	6.59	36.26	54.00	-17.74	Average	100	360
2	4874.00	41.77	6.59	48.36	74.00	-25.64	Peak	100	360

Notes:

1. Result = Read Value + Factor
2. Factor = Antenna Factor + Cable Loss - Amplifier
3. The resolution bandwidth of test receiver/spectrum analyzer is 120KHz and video bandwidth is 300kHz for Peak detection and Quasi-peak detection at frequency below 1GHz.
4. The resolution bandwidth of test receiver/spectrum analyzer is 1MHz and video bandwidth is 3MHz for Peak detection at frequency above 1GHz.
5. The resolution bandwidth of test receiver/spectrum analyzer is 1MHz and video bandwidth is 3MHz (detector sample mode) for Average detection at frequency above 1GHz.
6. The other emissions is too low to be measured. (The worst case noise floor measurements value is 47.93 dBuV at 16.10GHz)
7. The data is worse case.





Power	: AC 120V	Pol/Phase	: HORIZONTAL
Test Mode 1	: 802.11n HT20, CH6	Temperature	: 25 °C
Adapter	: DVE \ DSC-6PFA-05 FUS 050100	Humidity	: 67 %

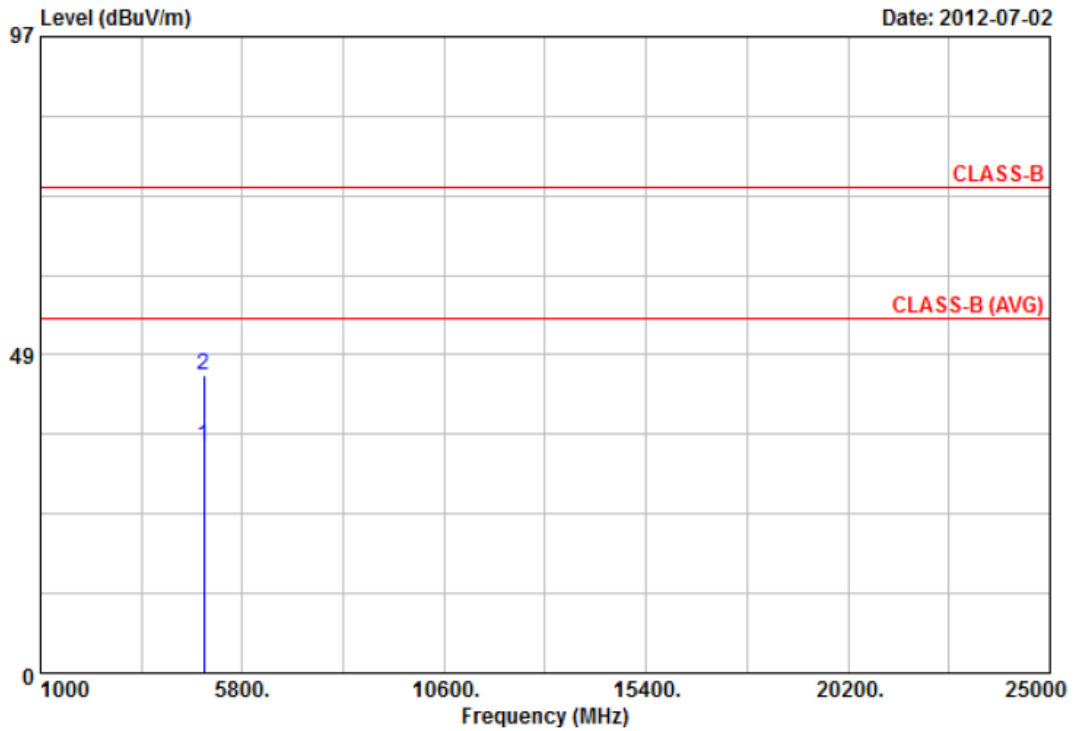

Item	Freq	Read		Factor	Result	Limit	Margin	Remark	Ant Pos	Tab Pos
		MHz	dBuV							
1	4874.00	29.73	4.73	34.46	54.00	-19.54	Average	100	0	
2	4874.00	40.55	4.73	45.28	74.00	-28.72	Peak	100	0	

Notes:

1. Result = Read Value + Factor
2. Factor = Antenna Factor + Cable Loss - Amplifier
3. The resolution bandwidth of test receiver/spectrum analyzer is 120KHz and video bandwidth is 300kHz for Peak detection and Quasi-peak detection at frequency below 1GHz.
4. The resolution bandwidth of test receiver/spectrum analyzer is 1MHz and video bandwidth is 3MHz for Peak detection at frequency above 1GHz.
5. The resolution bandwidth of test receiver/spectrum analyzer is 1MHz and video bandwidth is 3MHz (detector sample mode) for Average detection at frequency above 1GHz.
6. The other emissions is too low to be measured. (The worst case noise floor measurements value is 47.93 dBuV at 16.10GHz)
7. The data is worse case.



Power	: AC 120V	Pol/Phase	: VERTICAL
Test Mode 1	: 802.11n HT20, CH11	Temperature	: 25 °C
Adapter	: DVE \ DSC-6PFA-05 FUS 050100	Humidity	: 67 %

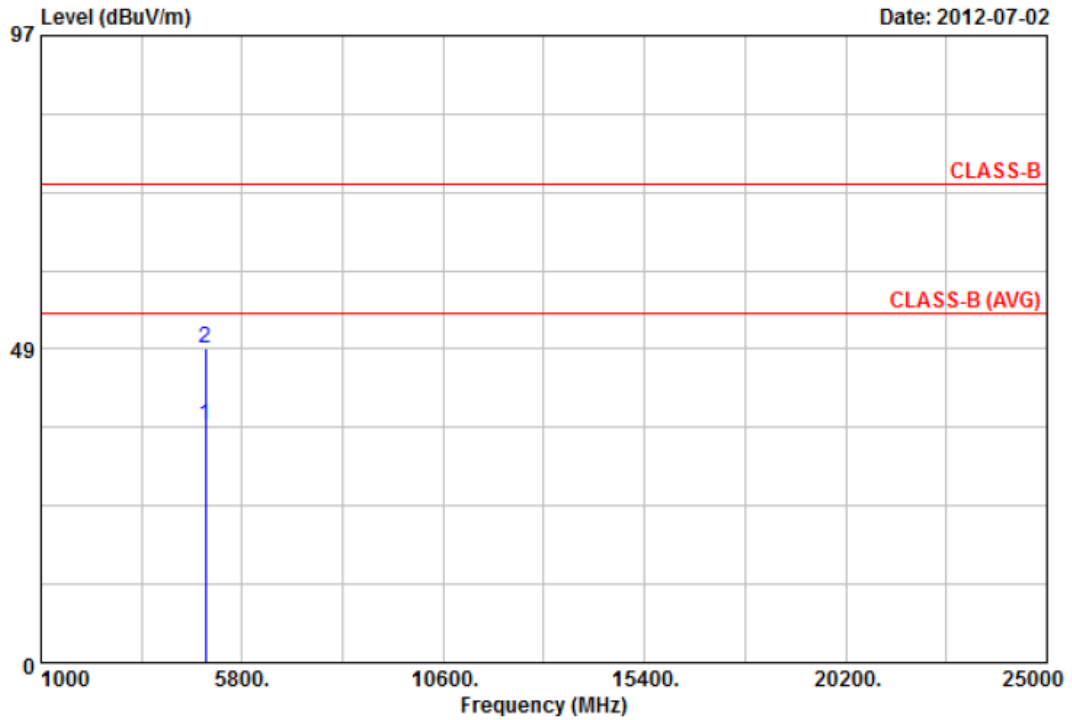

Item	Freq	Read Value	Factor	Result	Limit	Margin	Remark	Ant Pos	Tab Pos
	MHz	dBuV	dB/m	dBuV/m	dBuV/m	dB		cm	Deg
1	4924.00	29.51	7.16	36.67	54.00	-17.33	Average	100	360
2	4924.00	41.44	7.16	48.60	74.00	-25.40	Peak	100	360

Notes:

1. Result = Read Value + Factor
2. Factor = Antenna Factor + Cable Loss - Amplifier
3. The resolution bandwidth of test receiver/spectrum analyzer is 120KHz and video bandwidth is 300kHz for Peak detection and Quasi-peak detection at frequency below 1GHz.
4. The resolution bandwidth of test receiver/spectrum analyzer is 1MHz and video bandwidth is 3MHz for Peak detection at frequency above 1GHz.
5. The resolution bandwidth of test receiver/spectrum analyzer is 1MHz and video bandwidth is 3MHz (detector sample mode) for Average detection at frequency above 1GHz.
6. The other emissions is too low to be measured. (The worst case noise floor measurements value is 47.93 dBuV at 16.10GHz)
7. The data is worse case.



Power	: AC 120V	Pol/Phase	: HORIZONTAL
Test Mode 1	: 802.11n HT20, CH11	Temperature	: 25 °C
Adapter	: DVE \ DSC-6PFA-05 FUS 050100	Humidity	: 67 %

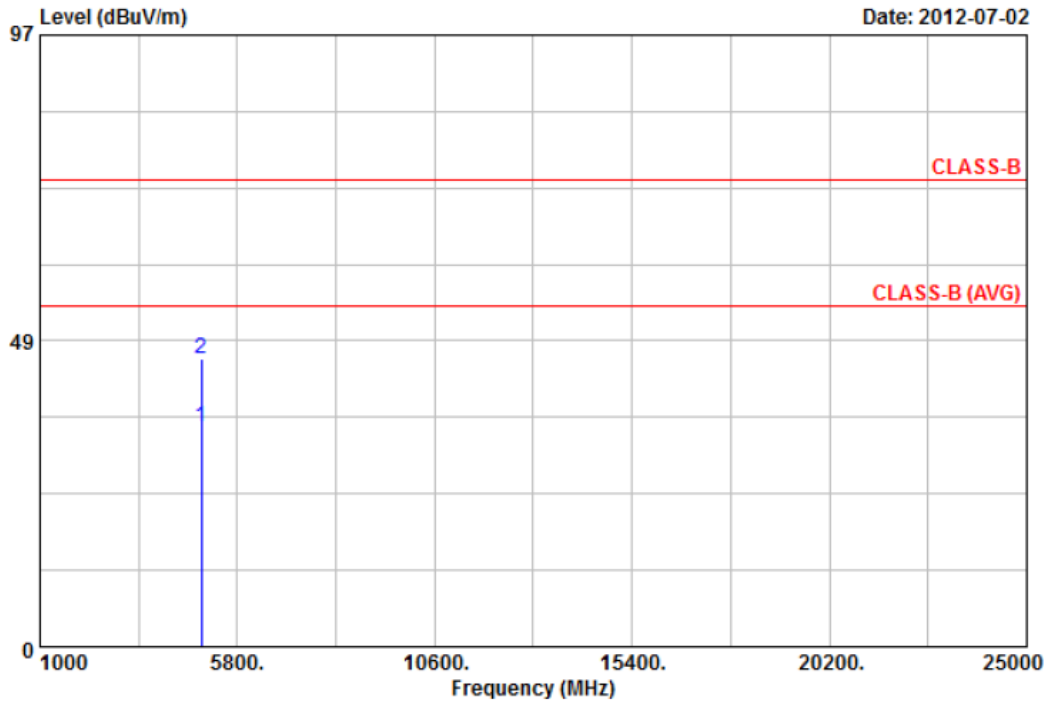

Item	Freq	Read Value	Factor	Result	Limit	Margin	Remark	Ant Pos	Tab Pos
	MHz	dBuV	dB/m	dBuV/m	dBuV/m	dB		cm	Deg
1	4924.00	29.78	5.15	34.93	54.00	-19.07	Average	100	0
2	4924.00	40.54	5.15	45.69	74.00	-28.31	Peak	100	0

Notes:

1. Result = Read Value + Factor
2. Factor = Antenna Factor + Cable Loss - Amplifier
3. The resolution bandwidth of test receiver/spectrum analyzer is 120KHz and video bandwidth is 300kHz for Peak detection and Quasi-peak detection at frequency below 1GHz.
4. The resolution bandwidth of test receiver/spectrum analyzer is 1MHz and video bandwidth is 3MHz for Peak detection at frequency above 1GHz.
5. The resolution bandwidth of test receiver/spectrum analyzer is 1MHz and video bandwidth is 3MHz (detector sample mode) for Average detection at frequency above 1GHz.
6. The other emissions is too low to be measured. (The worst case noise floor measurements value is 47.93 dBuV at 16.10GHz)
7. The data is worse case.



Power	: AC 120V	Pol/Phase	: VERTICAL
Test Mode 1	: 802.11n HT40, CH3	Temperature	: 25 °C
Adapter	: DVE \ DSC-6PFA-05 FUS 050100	Humidity	: 67 %

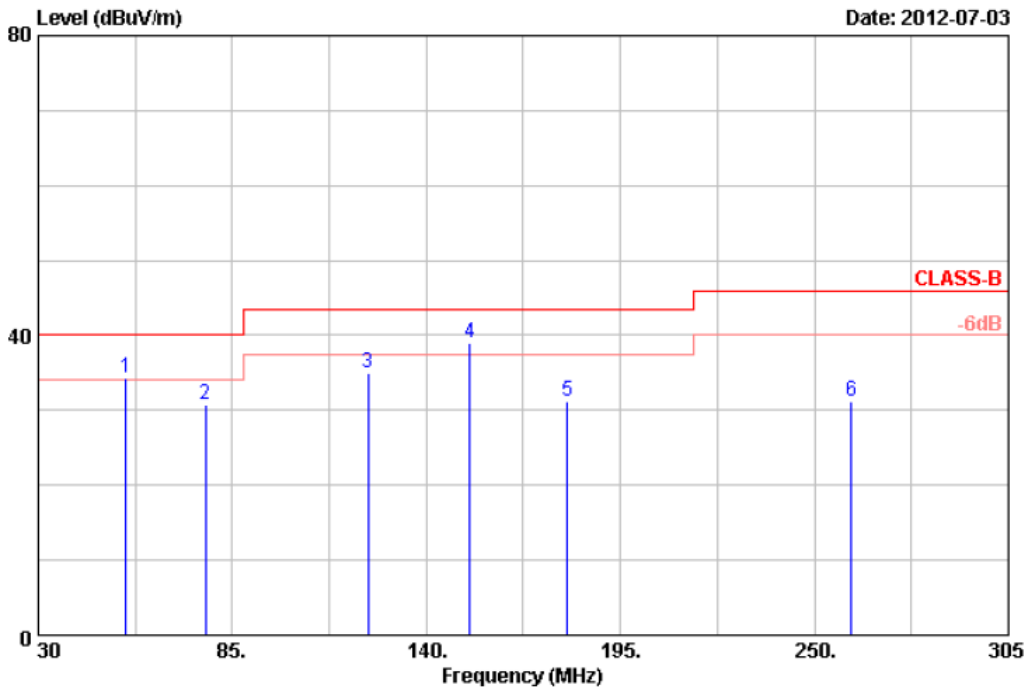

Item	Freq	Read Value	Factor	Result	Limit	Margin	Remark	Ant Pos	Tab Pos
	MHz	dBuV	dB/m	dBuV/m	dBuV/m	dB		cm	Deg
1	54.75	46.63	-12.23	34.40	40.00	-5.60	QP	100	360
2	77.30	39.63	-8.84	30.79	40.00	-9.21	QP	100	360
3	123.50	39.78	-4.84	34.94	43.50	-8.56	Peak	100	360
4	152.38	51.13	-12.05	39.08	43.50	-4.42	Peak	100	360
5	179.88	36.33	-5.06	31.27	43.50	-12.23	Peak	100	360
6	260.45	38.98	-7.72	31.26	46.00	-14.74	Peak	100	360

Notes:

1. Result = Read Value + Factor
2. Factor = Antenna Factor + Cable Loss - Amplifier
3. The resolution bandwidth of test receiver/spectrum analyzer is 120KHz and video bandwidth is 300KHz for Peak detection and Quasi-peak detection at frequency below 1GHz.
4. All below 1GHz configurations are pretested among available 802.11b/g/n modes and found that the worst cases are on channel 1 of 802.11g & n20 mode and Channel 3 for n40 mode. Only worst case data concluded above were presented in this test report.
5. The data is worse case.