

Classroom Audio System



User Manual

TABLE OF CONTENTS

SECTION 1:	4	Important Safety Instructions
Overview	5	System Components and Unpacking
	6	Optional Components
	7	Front Panel Indicators
	7	Top Panel Controls and Connections
	8	Side Panel Controls and Connections
	8	Rear Panel Features
	9	Flexmike Controls and Connections
SECTION 2:	10	Step 1. Determine Set-up Location
Set-up & Use	10	1A. <i>To Set-Up on Table Top</i>
	11	1B. <i>To Set-Up Mounted on a Wall</i>
	13	Step 2. Connecting the Power Supply
	14	Step 3. Audio Integration
	15	Step 4. Charging the Flexmike
	16	Step 5. Operating the Flexmike
	17	Step 6. Output to Assistive Listening Device (ALD)
	18	Step 7. Using the Flexmike as a Wireless Audio Link
SECTION 3:	19	Daily Operation Instructions
Daily Operation		
SECTION 4:	20	Battery Pack Replacement in a Flexmike
Maintenance & Troubleshooting	21	Troubleshooting Guide
	22	Tips to Obtain Optimal Audio Performance
SECTION 5:	23	Warranty Statement
Warranty & Specifications	24	Safety Warnings and Certifications
	28	System Specifications

IMPORTANT SAFETY INSTRUCTIONS

1. Read these instructions.
2. Keep these instructions.
3. Heed all warnings.
4. Follow all instructions.
5. Do not use the apparatus near water.
6. Clean only with dry cloth.
7. Do not block any ventilation openings. Install in accordance with the manufacturer's instructions.
8. Do not install near any heat sources such as radiators, heat registers, stoves, or other apparatus (including amplifiers) that produce heat.
9. Do not defeat the safety purpose of the polarized or grounding-type plug. A polarized plug has two blades with one wider than the other. A grounding-type plug has two blades and a third grounding prong. The wide blade or the third prong is provided for your safety. If the provided plug does not fit into your outlet, consult an electrician for replacement of the obsolete outlet.
10. Protect the power cord from being walked on or pinched particularly at plugs, convenience receptacles, and the point where they exit from the apparatus.
11. Only use attachments/ accessories specified by the manufacturer.
12. Use only with a cart, stand, tripod, bracket or table specified by the manufacturer, or sold with the apparatus. When a cart is used, use caution when moving the cart/apparatus combination to avoid injury from tip-over. 
13. Unplug this apparatus during lightning storms or when unused for long periods of time.
14. Refer all servicing to qualified service personnel. Servicing is required when the apparatus has been damaged in any way, such as power-supply cord or plug is damaged, liquid has been spilled or objects have fallen into the apparatus, the apparatus has been exposed to rain or moisture, does not operate normally, or has been dropped.
15. When the mains plug or appliance coupler is used as the disconnect device, it shall remain readily operable.
16. Please keep the unit in a good ventilation environment.
17. **WARNING:** To reduce the risk of fire or electric shock, do not expose this apparatus to rain or moisture.
18. Apparatus shall not be exposed to dripping or splashing and no objects filled with liquids, such as vases, shall be placed on the apparatus.
19. Warning - battery pack shall not be exposed to excessive heat such as sunshine, fire or the like.

SECTION 1:

OVERVIEW

SYSTEM COMPONENTS AND UNPACKING

The standard configuration of the Redcat Access will contain:

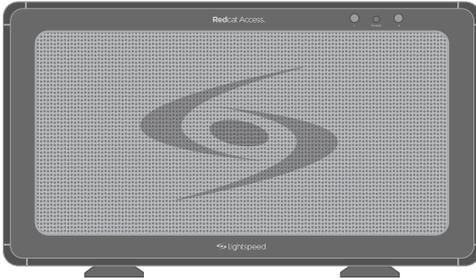

Redcat Access Receiver/
Amplifier and Power
Supply

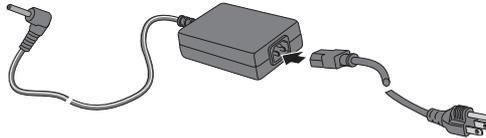

Flexmike
Classroom
Microphone



Wall Charger &
Charging Cable

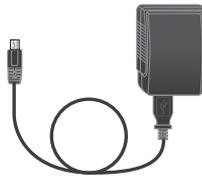

PLEASE NOTE: The Redcat Access and Microphone(s) are registered together at the factory and are labeled as such. Please keep all components together as a system. Moving them from one system, or room, to another will result in the need to re-register them to function.

5. Warranty, Safety
& Specifications

4. Maintenance &
Troubleshooting

3. Optional Accessories

2. Set Up & Use /
Daily Operation

1. Overview

Standard Accessories

RCA	Redcat Access all-in-one system
16V-2.0-NA	16V/2.0A power supply for Redcat Access, U.S. and Canada
16V-2.0- <u> </u>	16V/2.0A power supply for Redcat Access, specify country
FM	Flexmike classroom microphone with battery pack
NH2.4V	AA NiMH rechargeable battery pack for Flexmike, one per Flexmike
FL	Flexmike lavalier cord
USB2-NA	Transmitter wall charger, U.S. and Canada
USB2-INT	Transmitter wall charger, specify country
USB-MCB	USB Type A-Micro B charging cable for Flexmike

Optional Accessories

FCAD-4	Flexcat for small group instruction*
SM	Handheld microphone with battery pack
NH2APK	AA NiMH rechargeable battery pack for Sharemike, one per Sharemike
USBDC-5	Charging cable for Sharemike



*For further information on Flexcat for small group instruction, please visit www.lightspeed-tek.com

FRONT PANEL INDICATORS

1. **POWER ON INDICATOR:** The power light will glow blue when power is applied.
2. **MIC 1 & MIC 2:** Mic link and registration indicators
 - a. Flashing amber indicates registration is in process.
 - b. Solid green indicates a link has been established.

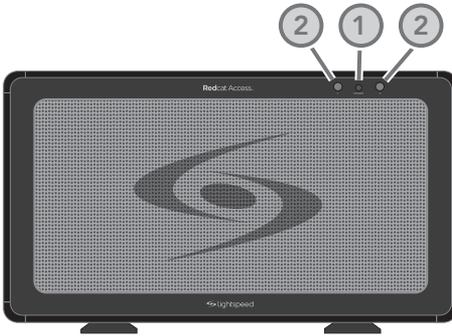

TOP PANEL CONTROLS

1. **MIC VOLUME:** Controls the volume level of the microphones.
2. **tone CONTROL:** Adjusts the audio tone, adding more bass or treble for a more rich or crisp sound.



5. Warranty, Safety & Specifications

4. Maintenance & Troubleshooting

3. Optional Accessories

2. Set Up & Use / Daily Operation

1. Overview

SIDE PANEL CONTROLS AND CONNECTIONS

- 1. REGISTRATION:** Press this button if there is a new component, such as a microphone, to be registered.
- 2. AUDIO INPUT JACK & VOLUME CONTROL:** 3.5mm stereo connector for connecting classroom audio sources to the Redcat Access. Controls the volume level of the audio input from the connected audio source.
- 3. AUDIO OUTPUT JACK & VOLUME CONTROL:** 3.5mm stereo connector for connecting to an assisted listening device (ALD) or to a computer for recording. Controls the volume level of the audio output.
- 4. POWER BUTTON:** This button is used to turn the Redcat Access on or off. The front panel blue light will glow when power is on.
- 5. DC INPUT JACK:** Plug the power supply (16V/2.0A) into this jack.

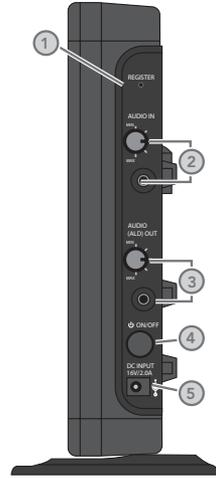

REAR PANEL FEATURES

- 1. CARRYING INSET:** Cutaway grip for moving or carrying the Redcat Access.
- 2. CABLE MANAGEMENT AND STRAIN RELIEF**
- 3. WALL MOUNTING SLOTS**
- 4. SECURITY BRACKET SLOT**

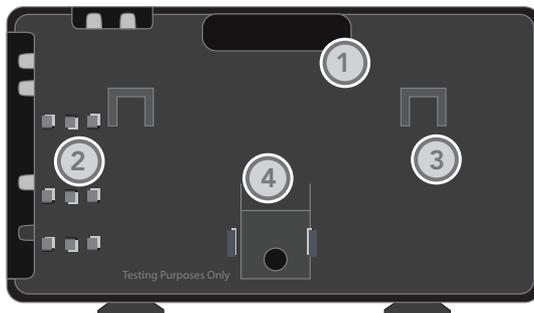

FLEXMIKE CONTROLS AND CONNECTIONS

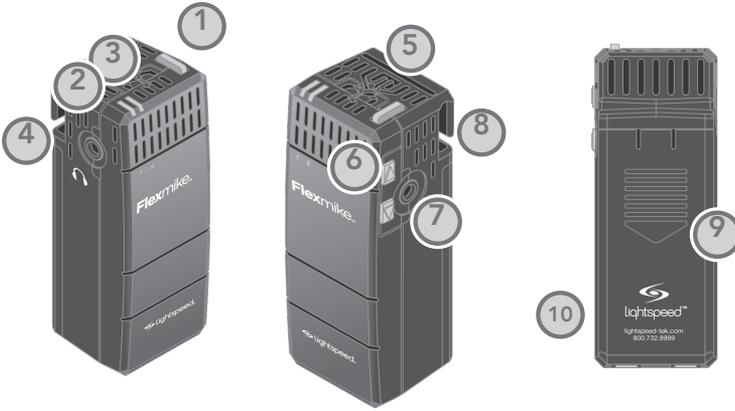

- 1. POWER/MUTE SWITCH:** press and hold to power on, press to mute, press and hold to power off.
- 2. MIC 1 STATUS:** lighted to indicate microphone is registered as MIC 1
 - Blue: solid = normal operation; Blue: flashing = linking in process
 - Red: solid = muted; Red: flashing = muted while linking in process
- 3. MIC 2 STATUS:** when using a second microphone, this LED is lighted to indicate microphone is registered as MIC 2 (same behavior as MIC 1 status light above)
- 4. EARBUD CONNECTION*:** connect the earbud for monitoring (*for use with Flexcat Pods only)
- 5. CHARGING/LOW BATTERY INDICATOR:** lights red when charging, green when fully charged. When in operation, turns red to indicate low battery.
- 6. MICROPHONE VOLUME UP/DOWN**
- 7. AUDIO INPUT:** connect audio source to send to Redcat Access
- 8. LANYARD INTERFACE:** insert the lanyard into this hook to wear the Flexmike.
- 9. BATTERY DOOR:** remove the battery door to replace the rechargeable battery pack
- 10. REGISTRATION:** (inside battery compartment - not shown) only used when adding or replacing Flexmike.

5. Warranty, Safety & Specifications

4. Maintenance & Troubleshooting

3. Optional Accessories

2. Set Up & Use / Daily Operation

1. Overview

SECTION 2:

SET-UP & USE

1. DETERMINE SET-UP LOCATION

The Redcat Access is shipped with feet to stand on a cabinet or tabletop. Alternatively, the feet can be used as wall mount brackets.

Advantages of either include:

Tabletop (recommended):

- Virtually no setup time
- Greater flexibility to move to different locations

Wall-mount:

- More permanent setup
- Greater security

1A. TO SET-UP ON TABLE-TOP

First, consider that the Redcat Access should be placed within 7 feet of an electrical outlet and on a surface about 3-6 feet off the ground.

Next, find a location as far away as possible from the teacher who will be using the mic. The best place is against the wall opposite where the

teacher will be speaking. If this is not possible, other good locations are along either wall next to the teacher or in a corner. Avoid placing the Redcat Access next to where the teacher instructs. Putting the Redcat Access in close proximity to the teacher's mic can result in feedback.

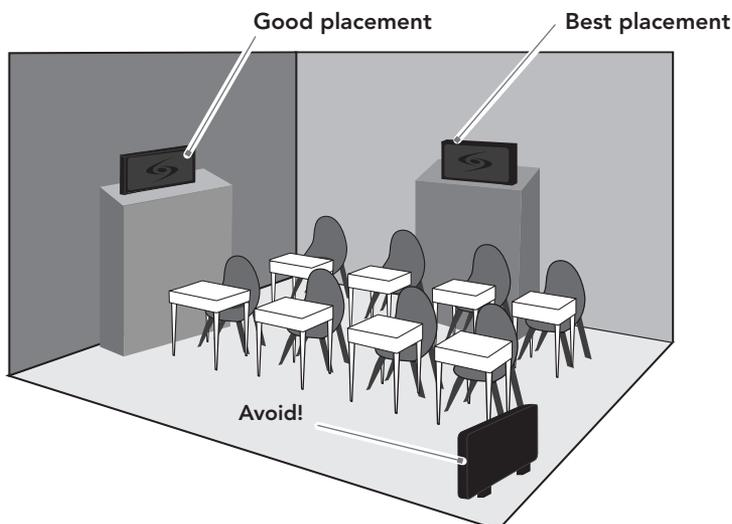

1B. TO SET-UP MOUNTED ON A WALL

First, consider that the Redcat Access should be placed within 7 feet of an electrical outlet and about 6-8 feet off the ground.

Next, find a location as far away as possible from the teacher who will be using the mic. The best place is centered on the long wall opposite

the teacher. If this is not possible, other good locations are on the wall next to the teacher. Avoid placing the Redcat Access on any wall close to where the teacher usually stands to instruct the class. Having the teacher's mic too close to the Redcat Access can result in feedback.

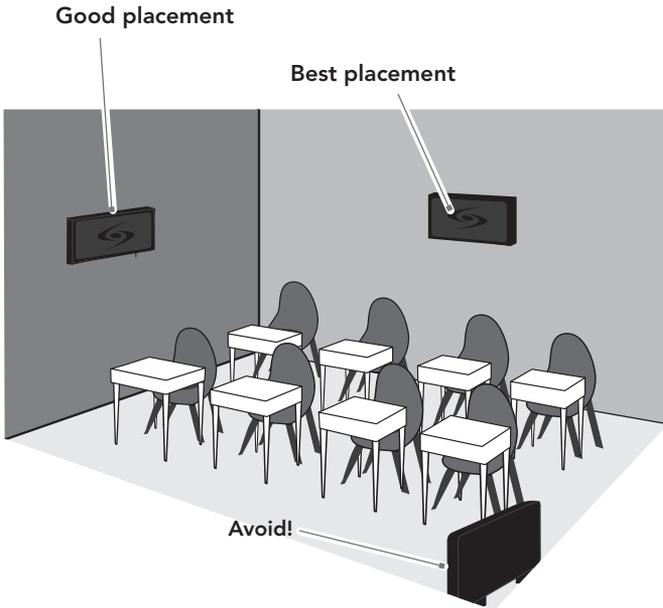

5. Warranty, Safety & Specifications

4. Maintenance & Troubleshooting

3. Optional Accessories

2. Set Up & Use / Daily Operation

1. Overview

1B. TO SET-UP MOUNTED ON A WALL CONT'D

1. Level template and tape to wall
2. Mark position of drill holes on wall
3. Drill pilot holes
4. Insert anchors
5. Remove feet from Redcat Access and place over anchors
6. Insert and secure screws through the Redcat Access feet into the anchors
7. If using optional security bracket, mount on wall using the provided screws and anchors
8. Slide the Redcat Access onto the wall mounted feet

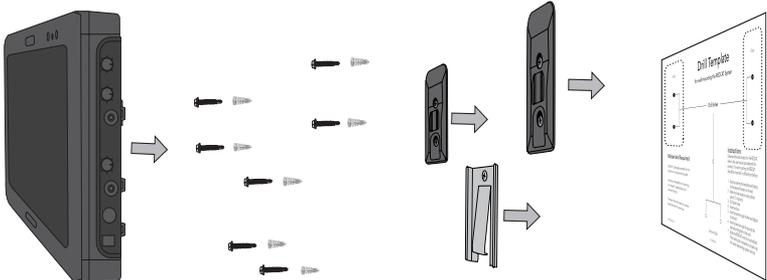
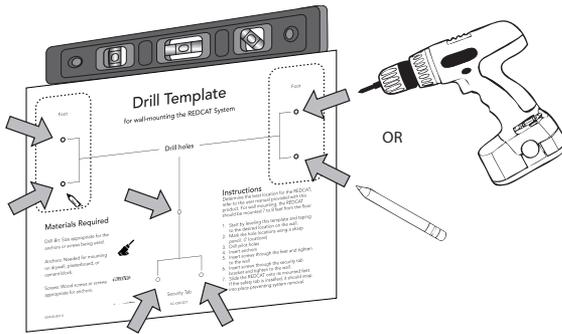

2. CONNECTING THE POWER SUPPLY

1. Locate the power supply and AC power cord. Connect the AC power cord into the DC power supply.

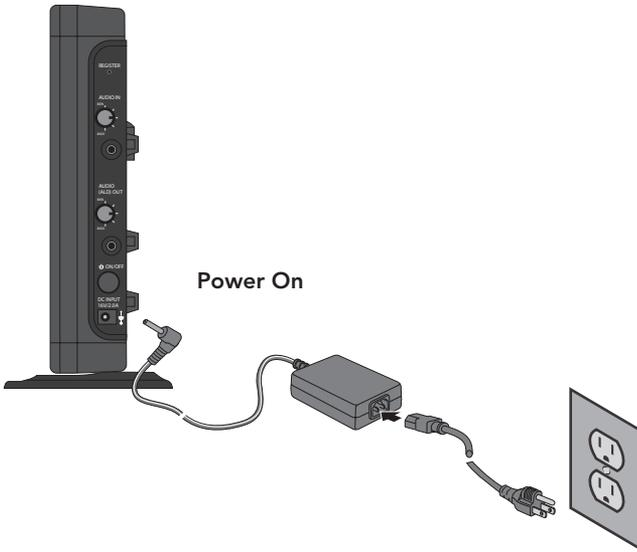

2. Insert the DC connector into the "DC INPUT" connector on the Redcat Access and plug the other end to an electrical outlet.
3. The Redcat Access automatically powers on and the blue power LED on the front panel will light.

5. Warranty, Safety & Specifications

4. Maintenance & Troubleshooting

3. Optional Accessories

2. Set Up & Use / Daily Operation

1. Overview

3. AUDIO INTEGRATION

The next step in setting up your Redcat Access system is to connect it to the other elements of your audio system. Audio systems have varying elements – you may have a computer, television, DVD/VCR player, a visual projection system or other devices. In this section you will find instructions on how to connect an external audio device like a TV, VCR, DVD, MP3 or computer directly into the Redcat Access.

Audio Input

The Redcat Access has one AUDIO INPUT with volume control for connecting to classroom audio sources. Use a patch cable (not included) to connect a computer, iPod, iPad, or other audio source.

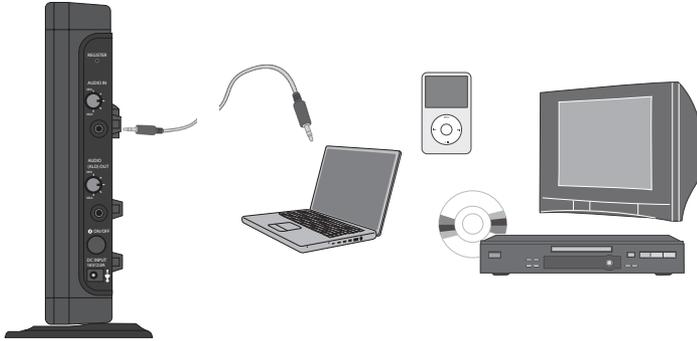

4. CHARGING THE FLEXMIKE

Before use, the Flexmike should be charged. It will take 8-9 hours for the Flexmike to obtain a full charge. A fully charged Flexmike will last for up to 8 hours of use. If microphones are used daily, they should be charged each night – microphones can be left charging constantly for up to 2 weeks without causing degradation to battery life.

When plugged into a charger, a red light on the Flexmike indicates the battery pack is charging. A green light indicates that charging is complete and a full charge has been reached. See Troubleshooting section for more information.

Replacement NiMH battery packs may only be purchased through Lightspeed Technologies (part # NH2.4V). Do not attempt to charge with other battery packs. They can overheat and expand creating a significant hazard and damaging the microphone (this is not covered by warranty).

1. Plug wall charger into an electrical outlet.
2. Plug the USB charging cable(s) into the wall charger.
3. Plug the micro USB end of the charging cable into USB port on the bottom of the Flexmike.
4. When the Flexmike is fully charged, the light on the mic will change to green.

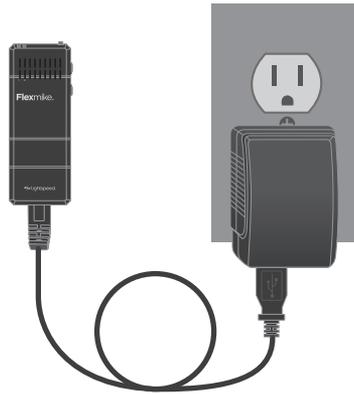

5. Hang the Flexmike on the lanyard opposite the magnetic clasp.



5. OPERATING THE FLEXMIKE

Once the Flexmike is charged, follow these steps to set it up for use.

1. Remove the Flexmike from the charging cable and put it on by connecting the magnetic clasps behind your neck. The Flexmike will automatically power on and mute when it is removed from the charger. This will automatically power on the Redcat Access as well.
2. The microphone volume on the Flexmike is set at the factory to the mid point.
3. While speaking in a normal voice, fine-tune the microphone volume on top of the Redcat Access up or down. Proper volume level should be as follows:
 - Your voice should be clearly heard by another person on the other side of the room.
 - You should barely be able to hear your own voice.
 - There should not be any audio "feedback" or squealing outside of 2-3 feet (if there is, turn the volume down slightly).



REMEMBER: This equipment supplements the user's voice so they are able to speak in a conversational tone. Having the volume set too high will result in feedback and listener fatigue.

4. Once initial volume level is set, walk around the room and listen for overall audio quality.
5. If further fine-tuning is required, you may need to adjust the Tone Control on the top of the Redcat Access.

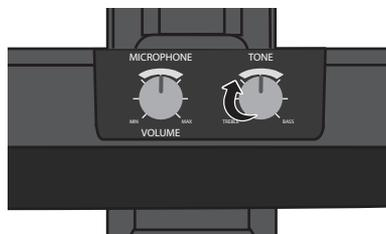

6. OUTPUT TO ASSISTIVE LISTENING DEVICE (ALD)

1. Turn the ALD (Assistive Listening Device) volume control on the Redcat Access side panel counterclockwise all way the down.
2. Determine the size and type of audio input jack on the device as many manufacturers' products differ in connector size and shape. The Lightspeed 370 Transmitter requires a 3.5mm to 3.5mm patch cable (part# MSC3535, not included).
3. Connect a patch cable from the ALD's microphone jack or AUX input to the 3.5mm audio jack labeled "ALD OUT" on the side
4. With the Redcat Access and ALD turned on, speak into the Flexmike and slowly adjust the ALD volume control until the appropriate audio level is attained in the ALD's receiver headphones.
5. It may be necessary to adjust the volume on the Personal FM receiver to achieve appropriate volume level.

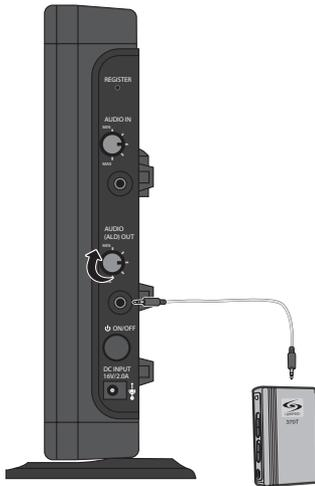

5. Warranty, Safety & Specifications

4. Maintenance & Troubleshooting

3. Optional Accessories

2. Set Up & Use / Daily Operation

1. Overview

7. USING FLEXMIKE AS WIRELESS AUDIO LINK

The Flexmike includes a 3.5mm audio input jack to connect to an audio source like a laptop or MP3 player. The Flexmike will transmit the audio signal to be played through the system.

If your system includes two Flexmikes, you can use one mic for instruction and the second mic to transmit audio through the system.

1. Plug your external audio equipment (for example, laptop), into the input on the Flexmike labeled "INPUT" using a 3.5mm patch cable (not included).

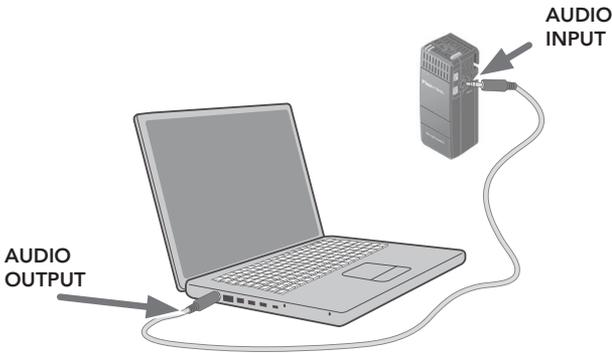

DAILY OPERATION INSTRUCTIONS



5. Warranty, Safety & Specifications

4. Maintenance & Troubleshooting

3. Optional Accessories

2. Set Up & Use / Daily Operation

1. Overview

1. At start of day, unplug the microphone from the charging cable and put on.

- The microphone will default to the Mute position, the status will turn to red.
- Place the microphone around your neck.
- Press the power/mute button, the status will turn blue, indicating the microphone is active and ready to use.
- Adjust volume with the UP/DOWN buttons if necessary.
- If Flexmike needs to be powered down for some time, press and hold the power button. To power Flexmike again, press and hold the power button until the blue light begins to blink.

Power /
Mute



2. Private conversations.

- Mute the Flexmike during private conversations by momentarily pressing the power button. When muted, the blue light turns red.
- When conversation is over, momentarily press the power button again to unmute the Flexmike.

3. End of day.

- Remove the Flexmike from around your neck.
- Plug the Flexmike into the charging cable and ensure the wall charger is plugged in to an outlet.
- The Flexmike will stay powered on during charging, but will automatically be muted.
- It is not necessary to turn off Redcat Access. If you do want to power it down, press the power button on side of Redcat Access. If Redcat Access is powered down, then when Flexmike is removed from charging the next day, it will automatically power the Redcat Access on.

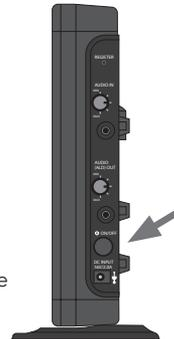

SECTION 3:

OPTIONAL ACCESSORIES

Sharemike: Controls and Connections

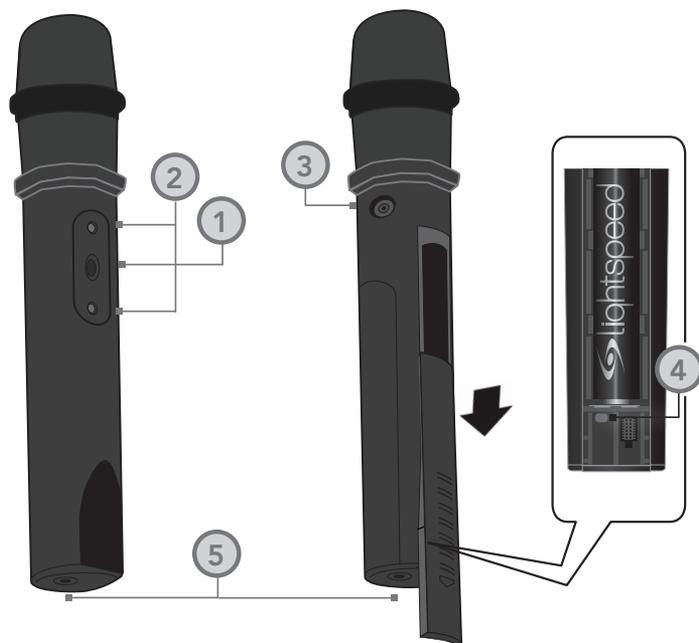

1. POWER BUTTON

2. MIC 1 or MIC 2 STATUS: lighted to indicate microphone is registered

- Blue: solid = normal operation; Blue: flashing = linking in process
- Red: solid = muted; Red: flashing = low battery

3. AUDIO INPUT: plug a laptop, MP3 player or other audio device into this jack to wirelessly transmit the audio signal to be played through the system.

4. REGISTRATION BUTTON: Located in the battery compartment, only used when adding or replacing Sharemike.

5. CHARGER INPUT: Plug the charging cable from the Sharemike charger into this jack.

Sharemike: Charging

1. Make sure the cradle charger is plugged into a wall outlet. Connect one end of the charging cable into the jack labeled CHARGER on the bottom of the Sharemike.
2. Plug the other end into the charging jack into the wall charger.
3. The light on the microphone will glow red to indicate charging.
4. Leave the Sharemike plugged in overnight (8-10 hours) to obtain a full charge. The light will turn green when charging is complete.



PLEASE NOTE: *The Redcat Access and Microphone(s) are registered together at the factory. If you have purchased a Sharemike with your Redcat Access, keep all components together as a system. Moving them from one system, or room, to another will result in the need to re-register.*

5. Warranty, Safety & Specifications

4. Maintenance & Troubleshooting

3. Optional Accessories

2. Set Up & Use / Daily Operation

1. Overview

Sharemike: Initial Set-up

1. Ensure the Redcat Access is on. The blue light on the front of the RCA will glow.
2. Turn on the Sharemike by sliding the pressing the power switch.
3. Grip the barrel in the center section.
4. While speaking in a normal voice, increase the VOLUME on the Redcat Access level until your voice is barely audible.

REMEMBER: This equipment is designed to supplement and distribute the user's voice so they are able to speak in a conversational tone. Having the volume set too high will result in feedback and listener fatigue.



SECTION 4:

MAINTENANCE & TROUBLESHOOTING

BATTERY REPLACEMENT

Replacement of battery pack in Flexmike.

1. Slide the battery door open.
2. Carefully pull the battery pack away from the Flexmike and disconnect the cable.



3. Connect the cable of the new battery pack as shown and insert the battery pack into the compartment.
4. Slide the cover back on and snap into place.
5. Connect the Flexmike to a charging cable and plug into the wall charger to charge the battery pack.

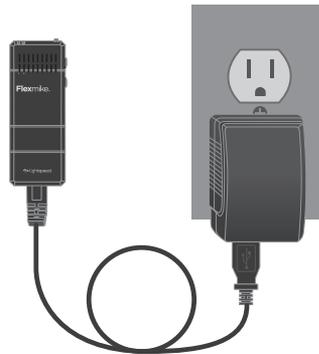

BATTERY REPLACEMENT, CONT'D

Replacement of battery pack in Sharemike.

1. Slide the battery door open.
2. Carefully remove the battery pack from the Sharemike.
3. Insert the new battery pack into the compartment. Ensure proper polarity is observed.
4. Slide the cover back on and snap into place.
5. Connect the Sharemike to a charging cable and plug into the wall charger to charge the battery pack.

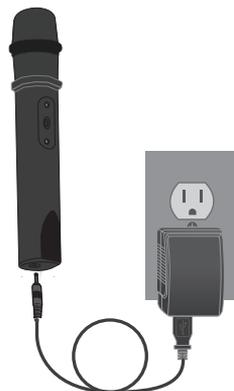

TROUBLESHOOTING

COMMON PROBLEMS AND SOLUTIONS

Note: Most problems are directly related to low battery power. Please run through the “Battery Check” items first. For remaining troubleshooting, use known good, fully-charged batteries.

ALL PROBLEMS: Most Problems are related to low battery power.

SOLUTION: Battery Check

- Confirm batteries are charged each night. A blinking red light on the power button indicates a low battery.
- Confirm proper batteries are used. The Flexmike requires the Lightspeed NH2.4V rechargeable battery pack. The Sharemike requires the Lightspeed NH2APK rechargeable battery pack.
- Make sure the microphones obtain a full charge. A full charge takes 8-9 hours.
- When plugging the charging cable into the transmitter, ensure the red charging light turns on. The green light will turn on when a full charge is reached.

PROBLEM: Microphone does not indicate a “Ready” signal (solid blue or red light)

SOLUTION: Follow these steps to ensure the system is ready to use.

- Ensure the power button on the microphone is turned on. Once turned on, the blue light should begin blinking.
- Power the microphone off, then on again after a few seconds. Wait for up to 30 seconds for the blue light

to turn solid, indicating READY for operation.

PROBLEM: Low Volume or Feedback

SOLUTION: Follow these steps to eliminate low volume or feedback.

- Check volume level on the amplifier. If the volume is too high, feedback will occur. Adjust accordingly.
- Adjust the volume level on the Flexmike.

PROBLEM: No Sound From Amplifier

SOLUTION: Follow these steps to produce sound from Redcat Access.

- Confirm that the blue POWER light located on the front panel of the Redcat Access is on.
- Confirm the microphone is linked to the Redcat Access. The mic 1 status light will be green on the Redcat Access indicating the microphone is linked.
- Confirm that the microphone is turned on. There will be a solid blue light on the top of microphone to indicate it is powered on and ready.
- Confirm that microphone is not muted. A solid red light on the top of microphone will indicate it is muted.

If you review these instructions and still have questions, call Lightspeed Technical Services at 800.732.8999, 5 a.m. – 5 p.m., PST. Customers outside the U.S. should contact their local reseller.

TIPS TO OBTAIN OPTIMUM AUDIO PERFORMANCE

- Speak in a natural voice. A normal conversational speech level will provide an adequate signal. It is not necessary to increase the intensity of your voice—the audio system provides adequate amplification (approximately 5 – 10 dB) above ambient room noises.
- Avoid wearing jewelry that may rub or bump against the microphone.
- Mute the Flexmike during private conversations with a student, parent, or other classroom visitor. You can tell the mic is muted when the light turns red.
- Recharge microphones each night. When recharged nightly, operating time (actual usage) for the microphones will last through a typical school day.

SECTION 5:

WARRANTY, SAFETY & SPECIFICATIONS

FIVE-YEAR LIMITED WARRANTY

Lightspeed Classroom Audio Access Systems are guaranteed against malfunction due to defects in materials and workmanship for a period of FIVE (5) YEARS, beginning at the date of the purchase invoice. If such malfunction occurs, the product will be repaired or replaced (at Lightspeed's option) without charge during the warranty period.

Lightspeed's Warranty Exchange Program applies to all classroom audio systems within the five (5) year warranty period. If a classroom audio product or component has an issue that requires service, a refurbished replacement will immediately be sent to the customer to minimize downtime. Customers will receive the exchange product(s) or component(s) within 2-3 days. A prepaid return label will be included with exchanged products so original malfunctioned equipment can be returned to Lightspeed. Any exchanged equipment will remain covered under the original five (5) year warranty.

1. Warranty on Access microphones is FIVE (5) YEARS.
2. Warranty on Lightspeed NiMH rechargeable batteries is one (1) year.
3. Prepaid shipping label provided by Lightspeed for warranty repairs within the United States. Customers outside the U.S. should refer to the Lightspeed website (www.lightspeed-tek.com) for warranty repair instructions.
4. Warranty does not extend to finish, appearance items, or malfunctions due to abuse or operation other than specified conditions, nor does it extend to incidental or consequential damages. Repair by other than Lightspeed or its authorized service agencies will void this warranty. Information on authorized service agencies is available from Lightspeed Technologies, Inc.

Our Service Department (800.732.8999, 5 a.m. – 5 p.m., PST) will handle all your repair/replacement needs. Customers outside the U.S. should contact their local reseller.

SAFETY WARNINGS AND CERTIFICATIONS



The lightning flash with arrowhead symbol inside an equilateral triangle is intended to alert the user to the presence of non insulated "hazardous voltage" within the product's enclosure, which may be of sufficient magnitude to induce a risk of electric shock to persons.



The exclamation mark inside an equilateral triangle is intended to alert the user to the presence of important operating and maintenance (servicing) instruction in the literature accompanying this product.



USE A LIGHTSPEED SUPPLIED BATTERY ONLY

CERTIFICATIONS



This product is listed to UL standards and requirements for electrical safety by Underwriters Laboratories Inc.



This product conforms with the essential requirements of the following European Union Directives: 2004/108/EC Electromagnetic Compatibility (EMC) and 2006/95/EC Low Voltage Directive (LVD).



Lightspeed Technologies launched a formal product recycle program in Europe that complies with the European Union Directive 2002/96/EC on Waste Electrical and Electronic Equipment ("WEEE Directive"). Please visit our website at www.Lightspeed-tek.com for more information.



This product is manufactured using lead-free processes and is free of other materials harmful to the environment. It conforms to the most stringent new European guidelines for consumer products (RoHS).

PRÉCAUTIONS DE SÉCURITÉ ET CERTIFICATIONS



ATTENTION
RISQUE D'ÉLECTROCUTION
NE PAS OUVRIR



CONFORMÉMENT AUX NORMES D'INSTALLATION APPLICABLES, CE PRODUIT DOIT ÊTRE INSTALLÉ PAR UNE PERSONNE FAMILIARISÉE AVEC LA CONCEPTION ET LE FONCTIONNEMENT DU PRODUIT ET CONSCIENTE DES RISQUE ENCOURUS.



L'éclair flèche dans un triangle équilatéral avertit l'utilisateur de la présence d'une "tension dangereuse" non isolée à l'intérieur de l'appareil, qui peut être d'une ampleur suffisante pour constituer un risque d'électrocution.



Le point d'exclamation contenu dans un triangle équilatéral avertit l'utilisateur de la présence d'importantes instructions d'exploitation et de maintenance dans la documentation qui accompagne ce produit.



UTILISEZ UNIQUEMENT LA BATTERIE LIGHTSPEED FOURNIE

CERTIFICATIONS



Ce produit est certifié conforme aux normes et aux exigences UL en matière de sécurité électrique par Underwriters Laboratories Inc.



Ce produit est conforme aux principales exigences des directives de l'Union Européenne suivantes : 2004/108/EC Electromagnetic Compatibility (EMC) and 2006/95/EC Low Voltage Directive (LVD).



Lightspeed Technologies a lancé un programme de recyclage de produits en Europe conformément à la directive de l'Union Européenne 2002/96/CE relative aux déchets d'équipements électriques et électroniques (directive « DEEE »). Veuillez visiter notre page Web www.Lightspeed-tek.com pour plus de renseignements.



Ce produit est fabriqué en utilisant des processus sans plomb ni aucune autre matière nuisible à l'environnement. Il est conforme aux nouvelles règles européennes les plus strictes en matière de biens de consommation (RoHS).

FCC Notice to user

This device complies with Part 15 of the FCC Rules. Operation is subject to the following two conditions:

- (1) This device may not cause harmful interference; and
- (2) This device must accept any interference received, including interference that may cause undesired operation.

This equipment has been tested and found to comply with the limits for a Class B digital device, pursuant to Part 15 of the FCC Rules. These limits are designed to provide reasonable protection against harmful interference in a residential installation.

This equipment generates, uses, and can radiate radio frequency energy and, if not installed and used in accordance with the instructions, may cause harmful interference to radio communications. However, there is no guarantee that interference will not occur in a particular installation.

If this equipment does cause harmful interference to radio or television reception, which can be determined by turning the equipment off and on, the user is encouraged to try to correct the interference by one or more of the following measures:

- Reorient or relocate the receiving antenna (that is, the antenna for radio or television that is receiving" the interference).
- Reorient or relocate and increase the separation between the telecommunications equipment and receiving antenna.
- Connect the telecommunications equipment into an outlet on a circuit different from that to which the receiving antenna is connected.

FCC RF Radiation Exposure Statement

For body worn operation, the portable part (Flexmike) has been tested and meets FCC RF exposure guidelines.

This device must not be co-located or operating in conjunction with any other antenna or transmitter. The changes or modifications not expressly approved by the party responsible for compliance could void the user's authority to operate the equipment.

Notice to Canada User

English

This device complies with Industry Canada licence exempt RSS standard(s).

Operation is subject to the following two conditions:

- (1) this device may not cause interference, and
- (2) this device must accept any interference, including interference that may cause undesired operation of the device.

French

Le présent appareil est conforme aux CNR d'Industrie Canada applicables aux appareils radio exempts de licence.

L'exploitation est autorisée aux deux conditions suivantes :

- (1) l'appareil ne doit pas produire de brouillage, et
- (2) l'utilisateur de l'appareil doit accepter tout brouillage radioélectrique subi, même si le brouillage est susceptible d'en compromettre le fonctionnement

RF Radiation Exposure Statement

English

Your mobile device is a radio transmitter and receiver. It is designed not to exceed the limits for exposure to radio waves (radio frequency electromagnetic fields) recommended by international guidelines. The guidelines were developed by Health Canada and include a substantial safety margin designed to assure the safety of all persons, regardless of age and health.

French

Votre appareil mobile est un émetteur-récepteur radio. Il est conçu pour ne pas dépasser les limites d'exposition aux ondes radio (champs électromagnétiques de fréquence radio) recommandées par les directives internationales. Les lignes directrices ont été élaborées par Santé Canada et comprennent une marge de sécurité importante destinée à assurer la sécurité de toutes les personnes, indépendamment de l'âge et de la santé.

NOTICE FOR USB

NOTE: Lightspeed is not responsible for any changes or modifications not expressly approved by the party responsible for compliance. Such modifications could void the user's authority to operate the equipment.

NOTE: This equipment has been tested and found to comply with the limits for a Class B digital device, pursuant to part 15 of the FCC Rules. These limits are designed to provide reasonable protection against harmful interference in a residential installation. This equipment generates, uses and can radiate radio frequency energy and, if not installed and used in accordance with the instructions, may cause harmful interference to radio communications. However, there is no guarantee that interference will not occur in a particular installation. If this equipment does cause harmful interference to radio or television reception, which can be determined by turning the equipment off and on, the user is encouraged to try to correct the interference by one or more of the following measures:

- Reorient or relocate the receiving antenna.
- Increase the separation between the equipment and receiver.
- Connect the equipment into an outlet on a circuit different from that to which the receiver is connected.
- Consult the dealer or an experienced radio/TV technician for help.

SYSTEM SPECIFICATIONS

REDCAT ACCESS SPEAKER

Power output:	20W
Acoustic frequency response:	120 Hz - 13 kHz
DC power Input:	16V / 2.0A
Total harmonic distortion	<1% @ 10W
Wireless communication:	Access Technology (1.9 GHz + RF4CE)
Tone control:	1 bass/treble control
Audio input:	3.5mm stereo w/ volume control
Audio output:	3.5mm stereo w/ volume control
Integrated speaker:	Exciter technology, flat-panel speaker
Audio Link indicators:	2 indicators for Flexmike 1 and 2
Device Registration:	Push button for pod(s), Flexmike(s), and remote(s)
Dimensions (W x H x D):	16" x 9" x 1.75" (406 x 241 x 45mm)
Weight:	2.9 lbs (1.3 kg)

FLEXMIKE (1-2):

Description:	pendant-style microphone
Earbud lanyard:	magnetic clasp with integrated earbud
Wireless communication:	Access Technology (1.9 GHz)
Audio distortion:	<1%
Integrated microphone:	uni-directional electret
Earbud output:	3.5mm
Audio input:	3.5mm
Volume control:	+/- 6 dB
Battery power:	2.5V NiMH battery pack
Battery life:	8 hours (fully charged)
Charging:	2 contacts for cradle charging
USB connection:	type Micro-B for charging and audio
Power:	on/off switch
Registration:	push button for registration with Redcat Access
Dimensions (L x W x H):	2.9" x 1.1" x 1.0" (74 x 28 x 25mm)
Weight:	1.8 oz (51 g)

SHAREMIKE

Description:	Handheld microphone
Wireless communication:	Access Technology (1.9 GHz)
Audio distortion:	<1%
Integrated microphone:	uni-directional electret
Audio input:	3.5mm
Battery power:	2. AA NiMH battery pack
Battery life:	8 hours (fully charged)
Charging:	5V charging jack
Power:	on/off button
Registration:	push button for registration with Red-cat Access
Dimensions (L x W x H):	2.25" x 2.25" x 8.75" (57.2 x 57.2 x 222.3mm)
Weight:	7.36 oz (208.7 g)

This page intentionally left blank



A C - M N R C A

LIGHTSPEED TECHNOLOGIES

11509 SW HERMAN ROAD / TUALATIN, OR 97062

TOLL FREE: 800.732.8999 / PHONE: 503.684.5538 / FAX: 503.684.3197

LIGHTSPEED-TEK.COM