

Flexible Audio for Group Learning

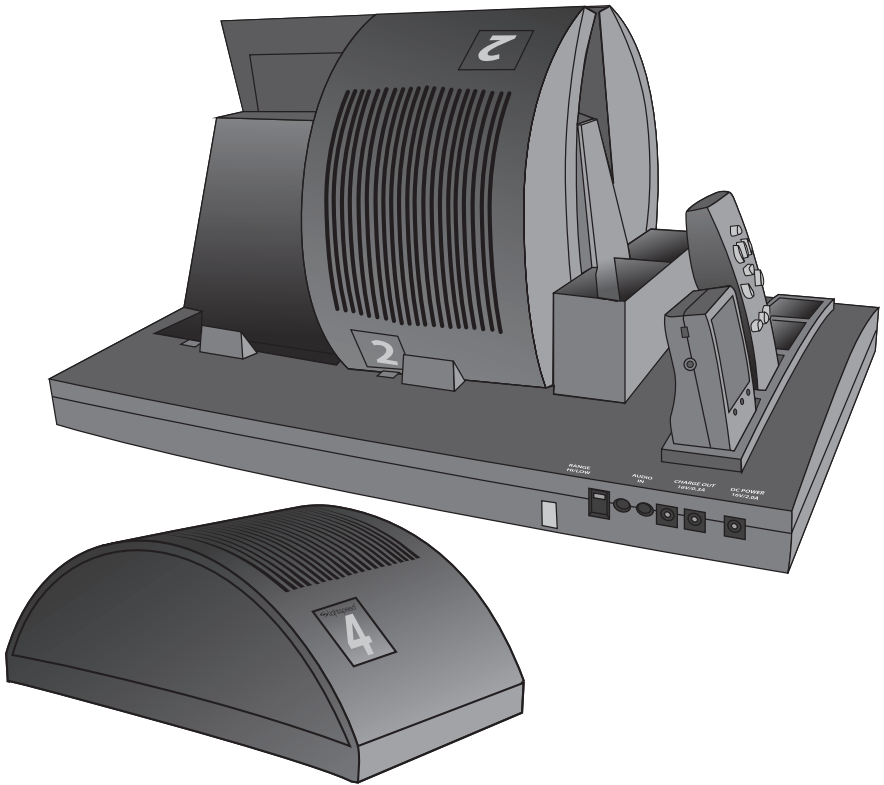

User Manual

TABLE OF CONTENTS

SECTION 1:	4	Important Safety Instructions
Overview	5	System Components and Unpacking
	6	Optional Components
	7	Charge Base Indicators
	8	Charge Base Connections
	9	Student Group Speaker Controls and Connections
	12	Teacher Belt-pack Controls and Functions
	13	Remote Control Functions and Indicators
	14	Headset Functions
SECTION 2:	16	1. Determine Set-up Location
Initial Set-up	17	2. Connect the Base Station
	18	3. Charge the FLEXCAT Components
	19	4. Power On All Components
	19	5. Ensure All Components Are Ready
	20	6. Wearing the Headset
	21	7. Determine Placement Location of Desktop Speakers
SECTION 3:	22	1. Operating the FLEXCAT
Daily Operation	23	Using the Remote
SECTION 4:	24	1. Tips and Tricks to Successful Use
Additional Information	25	2. Multimedia Audio Integration
	27	3. Connection to Assistive Listening Devices
	28	4. Using Optional Speakers #5-6
SECTION 5:	29	Registration of Replacement or Additional Equipment
Maintenance & Troubleshooting	30	Group Speaker Registration Process
	33	Belt-Pack Registration
	34	Remote Registration
	36	Battery Replacement
	39	Troubleshooting
SECTION 6:	41	Safety & Specifications
Maintenance & Troubleshooting	42	Safety Warnings and Certifications
	43	System Specifications

IMPORTANT SAFETY INSTRUCTIONS

1. Read these instructions.
2. Keep these instructions.
3. Heed all warnings.
4. Follow all instructions.
5. Do not use the apparatus near water.
6. Clean only with dry cloth.
7. Do not block any ventilation openings. Install in accordance with the manufacturer's instructions.
8. Do not install near any heat sources such as radiators, heat registers, stoves, or other apparatus (including amplifiers) that produce heat.
9. Do not defeat the safety purpose of the polarized or grounding-type plug. A polarized plug has two blades with one wider than the other. A grounding-type plug has two blades and a third grounding prong. The wide blade or the third prong is provided for your safety. If the provided plug does not fit into your outlet, consult an electrician for replacement of the obsolete outlet.
10. Protect the power cord from being walked on or pinched particularly at plugs, convenience receptacles, and the point where they exit from the apparatus.
11. Only use attachments/ accessories specified by the manufacturer.
12. Use only with a cart, stand, tripod, bracket or table specified by the manufacturer, or sold with the apparatus. When a cart is used, use caution when moving the cart/ apparatus combination to avoid injury from tip-over.
13. Unplug this apparatus during lightning storms or when unused for long periods of time.
14. Refer all servicing to qualified service personnel. Servicing is required when the apparatus has been damaged in any way, such as power-supply cord or plug is damaged, liquid has been spilled or objects have fallen into the apparatus, the apparatus has been exposed to rain or moisture, does not operate normally, or has been dropped.
15. When the mains plug or appliance coupler used as the disconnect device, it shall remain readily operable.
16. Please keep the unit in a good ventilation environment.

SECTION 1:

OVERVIEW

SYSTEM COMPONENTS AND UNPACKING

The standard configuration of the FLEXCAT will contain:

Charging base station
with power supply

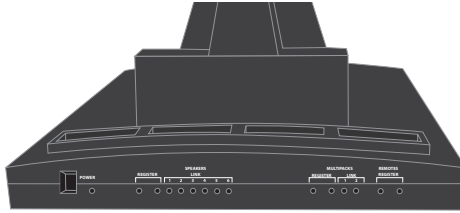

Student group
speakers (x4)

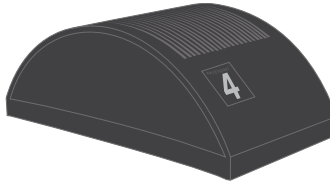

Teacher belt-pack (1)



Teacher headset (1)



Teacher remote
control (1)



6. Safety &
Specifications

5. Maintenance &
Troubleshooting

4. Additional
Information

3. Daily Operation

2. Initial Set-up

1. Overview

OPTIONAL COMPONENTS

Equipment which may be part of your FLEXCAT:

Additional student group speakers

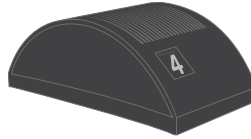

Team teaching kit:
2nd belt-pack, headset
and remote control

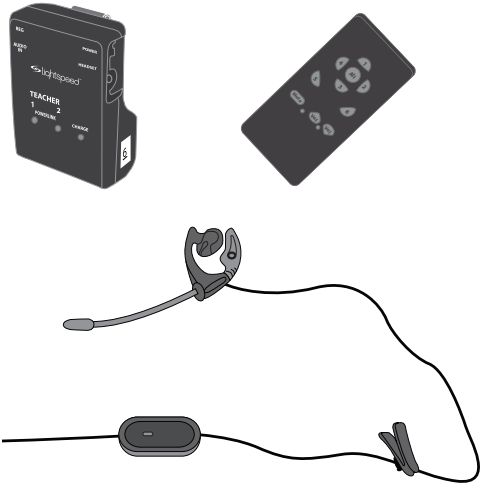

Standard Components

FCCB	FLEXCAT charging base station with power supply
FCGS	FLEXCAT student group speaker with rechargeable battery pack
FCTT	FLEXCAT team-teacher kit (belt-pack, headset & remote control)
FCBP	FLEXCAT teacher belt-pack with rechargeable battery pack
FCHRC	FLEXCAT handheld remote control with rechargeable battery pack
HS-FCOE	FLEXCAT over-ear headset
NH12V	12V NiMH rechargeable battery pack for group speakers
NH2.5V	2.5V NiMH rechargeable battery pack for belt-pack and remote

Optional Accessories

CA-16VCC	DC charging cable for optional group speakers #5-6
HS-MX500C	FLEXCAT under-ear headset
CA-MMC3535	3.5mm-3.5mm stereo audio cable

CHARGING BASE INDICATORS

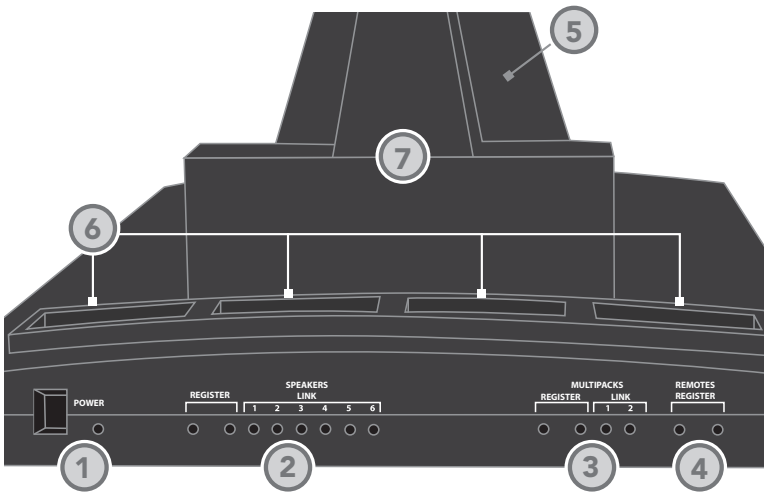

1. Power Switch and LED: turns the FLEXCAT system power on or off. The LED will glow blue when the system is on.

2. Student Group Speaker Register and Link

- Register:** press this button if there is a new speaker to be registered.
- Registration in progress:** this LED will turn yellow to indicate the base station is searching for a speaker.
- Link established (1-6):** these LEDs light up in green to indicate there is an audio link established with the corresponding group speaker.

3. Teacher belt-pack Register and Link

- Register:** press this button if there is a new teacher belt-pack to be registered.
- Registration in progress:** this LED will turn yellow to indicate the base station is searching for a teacher belt-pack.

c. Link established (1-2): these LEDs light up in green to indicate there is an audio link established with the corresponding teacher belt-pack.

4. Teacher Remote Link Button and Indicator

- Register:** press this button to search for a new teacher remote.
- Registration in progress:** this LED will turn yellow to indicate the base station is searching for a teacher remote.

5. Student group speaker charging slots (1-4): insert each of the group speakers into these slots for daily recharging.

6. Belt-pack/Remote charging slots: insert the belt-pack(s) and remote(s) into any of these charging slots (they are interchangeable) for daily recharging.

7. Headset storage: set the teacher headset(s) and excess wire into these storage slots during charging to keep equipment neat and organized.

6. Safety & Specifications

5. Maintenance & Troubleshooting

4. Additional Information

3. Daily Operation

2. Initial Set-up

1. Overview

CHARGING BASE CONNECTIONS

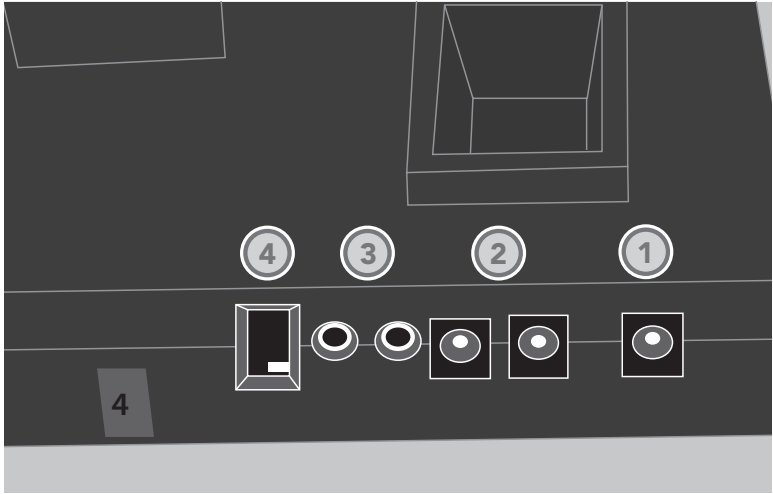

- 1. DC Power input:** Plug the power supply (16V/2.0A) into this jack.
- 2. Charging outputs:** these DC charging output connections are designed to charge 2 additional desktop speakers.
- 3. Audio inputs:** plug a 3.5mm cable from a computer or other audio device to play that audio through the desktop speaker(s).
- 4. High-low power setting:** this switch can expand the transmission range of the FLEXCAT system. Default setting should be low power.

STUDENT GROUP SPEAKER CONTROLS AND CONNECTIONS

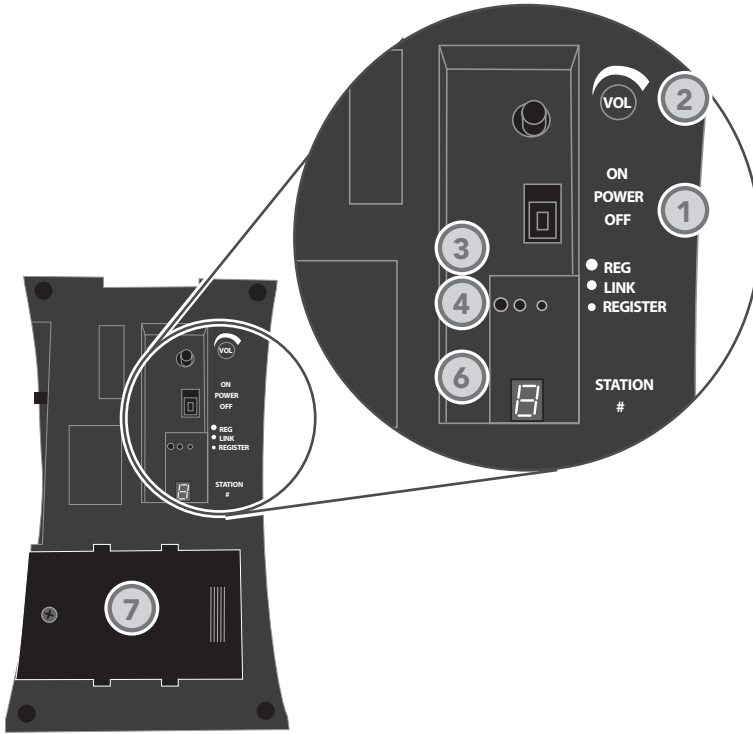

- 1. POWER SWITCH:** turns the speaker power on or off. The power shuts off automatically when charging.
- 2. VOLUME:** adjust the speaker volume up or down.
- 3. REGISTER:** press this button to register a new group speaker. The speaker comes pre-registered with the base station. This only needs to be activated if the speaker is replaced for service or an additional speaker is added.
- 4. REGISTRATION IN PROGRESS:** this LED will turn yellow to indicate the speaker is in process of registering with the base station.
- 5. SPEAKER "READY":** this green LED will light to indicate it is ready for operation. The link will take several seconds to be re-established each time it is powered on or removed from charging.
- 6. DESKTOP SPEAKER NUMBER:** this 7-segment LED indicates the group # this speaker has been registered to. This display should match the sticker on the topside of the speaker.
- 7. BATTERY COMPARTMENT:** remove screw and open to replace rechargeable battery pack.

6. Safety & Specifications

5. Maintenance & Troubleshooting

4. Additional Information

3. Daily Operation

2. Initial Set-up

1. Overview

STUDENT GROUP SPEAKER CONTROLS AND CONNECTIONS CONT'D

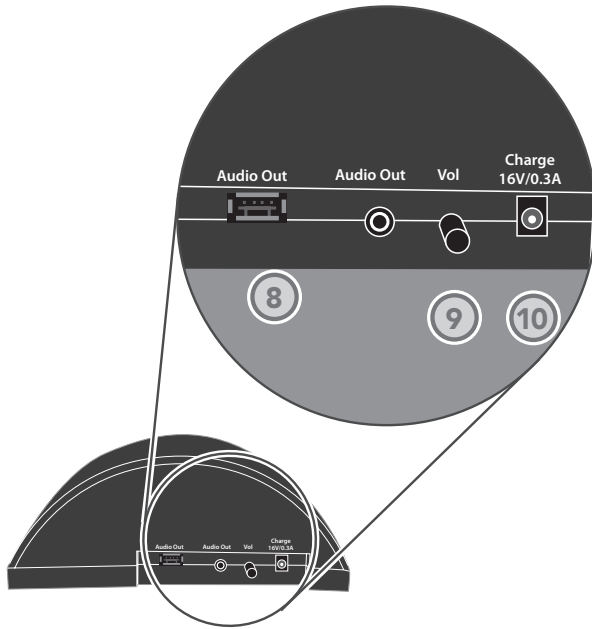

8. **USB AUDIO OUTPUT:** this USB connection acts only as an audio output, sending the signal out to an external device.
9. **AUDIO OUTPUT:** sends the audio signal from the tabletop speaker to an external device such as an Assistive Listening transmitter (ALD) or recording device.
10. **AUDIO OUTPUT VOLUME CONTROL:** adjusts the level of the 3.5mm audio output.
11. **DC CHARGING/POWER INPUT:** to charge optional group speaker #5-6, plug the charging cable from the base station into this jack.

STUDENT GROUP SPEAKER CONTROLS AND CONNECTIONS CONT'D



- 12. POWER/LOW BATTERY INDICATOR:** this Power LED turns blue when powered on, red when the battery is low.
- 13. CHARGING INDICATOR:** this LED turns RED when charging, green to indicate charging complete.
- 14. SPEAKER NUMBER STICKER:** this sticker acts as a clear visual indicator for the teacher to determine which speaker represents which group number.
- 15. LOUDSPEAKER:** the internal loudspeaker distributes the teacher's voice.
- 16. MICROPHONE:** the internal microphone that picks up the students' voice.

6. Safety & Specifications

5. Maintenance & Troubleshooting

4. Additional Information

3. Daily Operation

2. Initial Set-up

1. Overview

TEACHER BELT-PACK CONTROLS AND FUNCTIONS

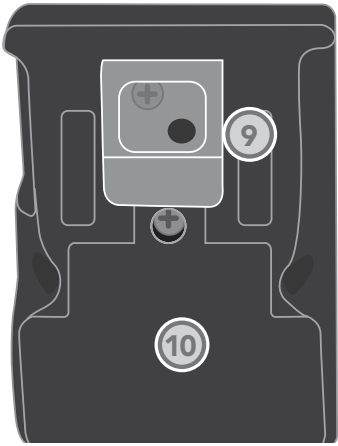

1. **POWER SWITCH:** powers the belt-pack on/off. Press up to power on. The power automatically shuts off for charging.
2. **TEACHER 1 STATUS INDICATOR:** this multi-purpose LED indicates power, low battery and ready for operation for the belt-pack registered as Teacher #1.
 - **Initial power on:** blinking blue
 - **"READY" for operation:** solid blue
 - **Low battery:** red
3. **TEACHER 2 STATUS INDICATOR:** this multi-purpose LED follows the same function as the Teacher 1 indicator for the belt-pack registered as Teacher #2.
4. **REGISTER:** press this button to register a new belt-pack. The belt-pack comes pre-registered with the base station. This only needs to be activated if the belt-pack is replaced for service or an additional one is added.
5. **REGISTRATION IN PROGRESS (NOT SHOWN):** the Teacher 1 and 2 status indicator LEDs will blink alternately to indicate the belt-pack is in process of registering.
6. **CHARGING INDICATOR:** this LED turns RED when charging, green to indicate charging complete.
7. **HEADSET CONNECTION:** the teacher headset connects to this 2.5mm jack.
8. **AUDIO INPUT:** connect an external device like an iPod or computer to send multimedia audio to any or all group speakers.
9. **BELT-CLIP:** use this clip to secure the belt-pack to a belt or pocket. Alternatively, the belt-pack can be placed inside the pocket.
10. **BATTERY COMPARTMENT:** remove screw and open to replace rechargeable battery pack.

REMOTE CONTROL FUNCTIONS AND INDICATORS

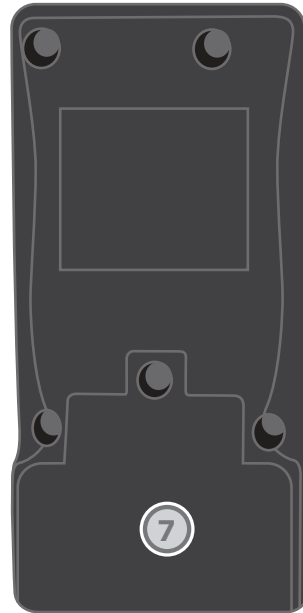
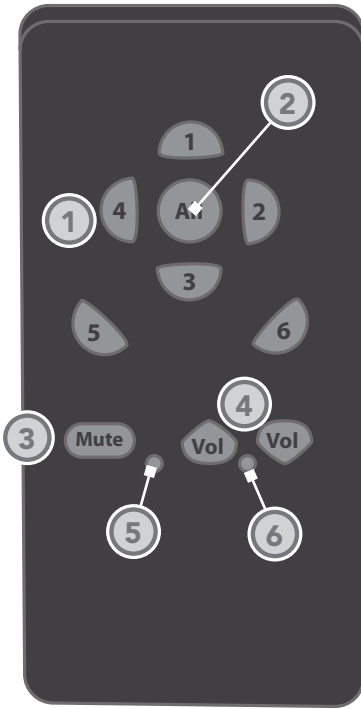

- 1. GROUP SPEAKER SELECTION (1-6):** press to select a specific speaker. The button turns green when addressing that group, red when monitoring (listening only).
- 2. ALL MODE:** press this button to address the whole class (all group speakers simultaneously).
- 3. MICROPHONE MUTE (MONITOR):** press this button to mute the microphone and monitor the different groups.
- 4. EARPIECE VOLUME:** these volume controls turn up and down the earpiece volume of the teacher headset, allowing you to hear the student groups at the appropriate volume level.
- 5. CHARGING INDICATOR:** This LED turns RED when charging and GREEN when fully recharged.
- 6. LOW BATTERY INDICATOR:** This LED turns RED when battery is low.
- 7. BATTERY COMPARTMENT:** remove screw and open to replace rechargeable battery pack

6. Safety & Specifications

5. Maintenance & Troubleshooting

4. Additional Information

3. Daily Operation

2. Initial Set-up

1. Overview

HEADSET FUNCTIONS

Standard over-ear headset:



- 1. EAR HOOK:** this rubber hook is designed to be placed over the ear. It can slide up or down to adjust for ear size and can be swiveled around the center post to allow the headset to be worn on the left or right side of the head.
- 2. MICROPHONE:** this microphone boom should be located near the mouth as shown in the diagram. It can rotate to be positioned either on the left or right side.
- 3. EAR PIECE:** the ear piece should be inserted into the ear canal as pictured.
- 4. CONNECTOR:** insert this 2.5mm connector into the headset connection on the belt-pack.

HEADSET FUNCTIONS CONT'D

Optional under-ear headset:

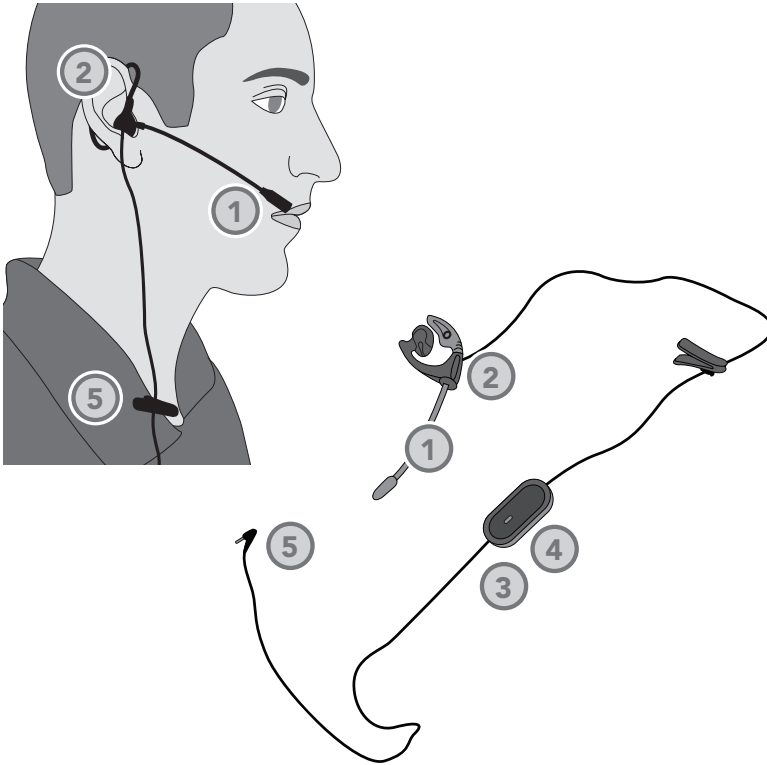

- 1. MICROPHONE:** this microphone boom should be located near the mouth as shown in the diagram. It can rotate to be positioned either on the left or right side.
- 2. EAR PIECE:** the ear piece should be inserted into the ear canal as pictured. It can be swiveled to fit on either the left or right ear.
- 3. MICROPHONE MUTE:** as an alternate to the remote control, you can press this button on the headset to mute the microphone (NOT RECOMMENDED).
- 4. EAR PIECE VOLUME:** as an alternate to the remote control, you can move this dial up or down to adjust ear piece volume (NOT RECOMMENDED).
- 5. CONNECTOR:** insert this 2.5mm connector into the headset connection on the belt-pack.

SECTION 2:**INITIAL SET-UP****1. DETERMINE SET-UP LOCATION**

The FLEXCAT base station can be set up anywhere in the classroom, but it is best suited to be in a location near the teachers desk and is highly accessible for both teachers and students.

Key considerations:

- Close proximity to AC power outlet
- Accessible for daily charging of all components
- Close proximity to audio source (computer) for multimedia integration

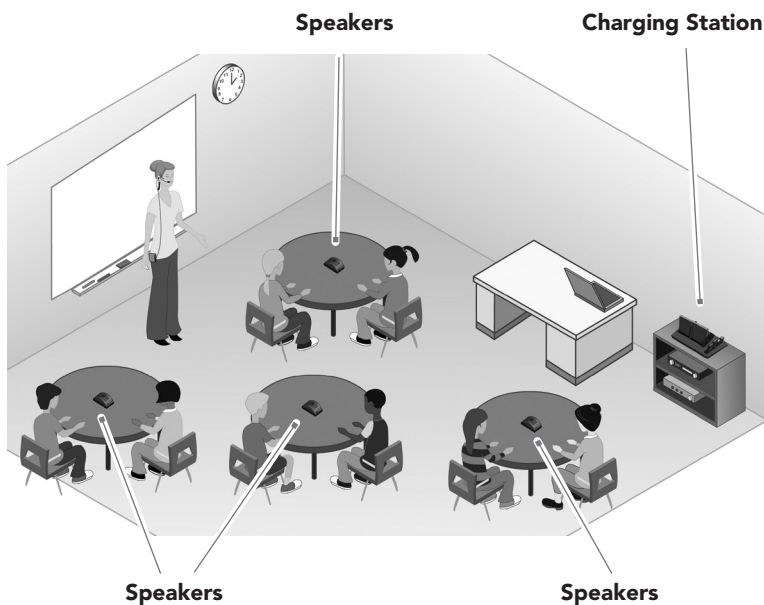

2. CONNECT THE BASE STATION

1. Locate the power supply and AC power cord. Connect the AC power cord into the DC power supply.
2. Plug the AC power cord into an electrical outlet.
3. Insert the DC connector into the "DC POWER INPUT" jack on the base station.

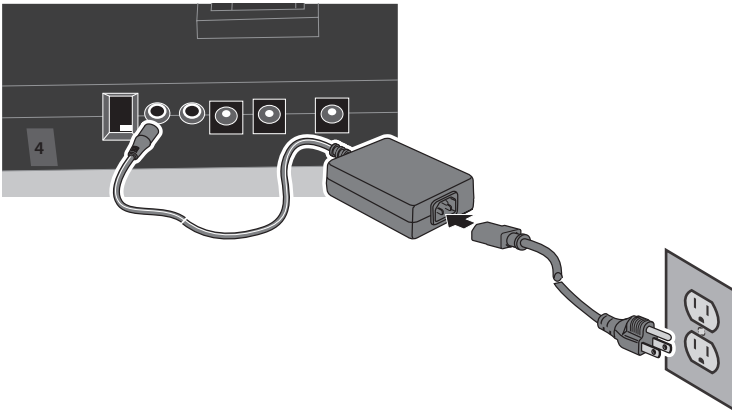

4. Switch the power to the ON position.

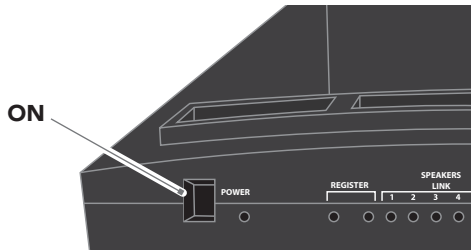

6. Safety & Specifications

5. Maintenance & Troubleshooting

4. Additional Information

3. Daily Operation

2. Initial Set-up

1. Overview

3. CHARGE THE FLEXCAT COMPONENTS

Prior to full operation, all system components should be fully charged (up to 8 hours) to ensure optimum performance.

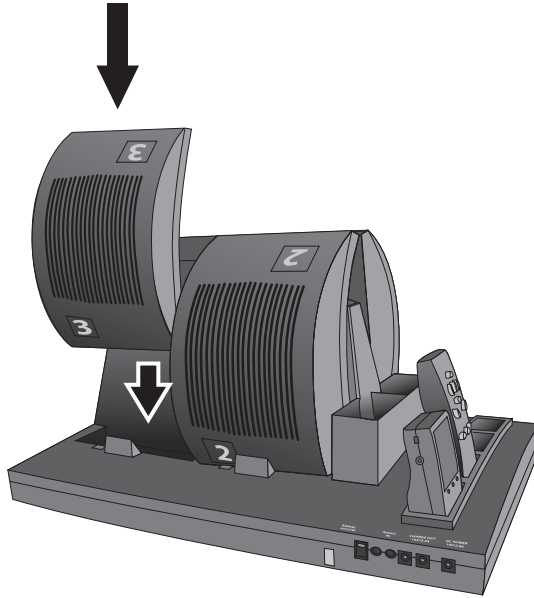

1. Insert all four group speakers into the charging cradle. The charging LED will turn RED to indicate normal charging. When fully charged, it will turn GREEN.
2. Insert the teacher belt-pack(s) into the charging cradle. Any of the four small slots are compatible. The charging LED will turn RED to indicate normal charging. When fully charged, it will turn GREEN.
3. Insert the teacher remote(s) into the charging cradle. Any of the four small slots are compatible. The charging LED will turn RED to indicate normal charging. When fully charged, it will turn GREEN.

4. POWER ON ALL COMPONENTS

- 1. DESKTOP SPEAKERS:** Locate the power switch on the bottom of all four speakers. Switch to the ON position. The station number LED will light as will the blue power on indicator.
- 2. TEACHER BELT-PACK:** Locate the power switch on the side of the unit. Switch to the ON position. The blue teacher indicator will flash for several seconds and then turn solid to indicate it is ready for use.
- 3. TEACHER REMOTE:** There is no power switch on this component, it stays in the ON position.

5. ENSURE ALL COMPONENTS ARE READY

- 1. DESKTOP SPEAKERS:** The amber colored LED on the bottom of the desktop speaker will light after a few seconds to indicate it is ready for operation.
- 2. TEACHER BELT-PACK:** The Teacher 1 or Teacher 2 LED will turn solid blue to indicate it is ready for operation.
- 3. TEACHER REMOTE:** Press ALL button to test. If the button lights, the remote is ready.

6. Safety & Specifications

5. Maintenance & Troubleshooting

4. Additional Information

3. Daily Operation

2. Initial Set-up

1. Overview

6. WEARING THE HEADSET

- 1. Determine which side of the face you would like to wear it on.** The ear hook and microphone boom can be rotated to wear on either side. Adjust as necessary.
- 2. Place headset onto the ear and adjust.** Place the hook over the ear and insert the earpiece into the ear canal. Adjust the headset is needed so the microphone boom is near the mouth.
- 3. Connect the headset to the belt-pack.** Insert the 2.5mm connector into the headset input on the belt-pack.



7. DETERMINE PLACEMENT LOCATION OF THE DESKTOP SPEAKERS

The desktop speakers should be placed in the middle of four different student groups or learning stations as follows:

- Placed on a stable, flat surface
- Within 3-6 feet of all students in that group
- Top surface of the speaker should be clear with nothing set on top to ensure optimum sound quality and microphone pickup.

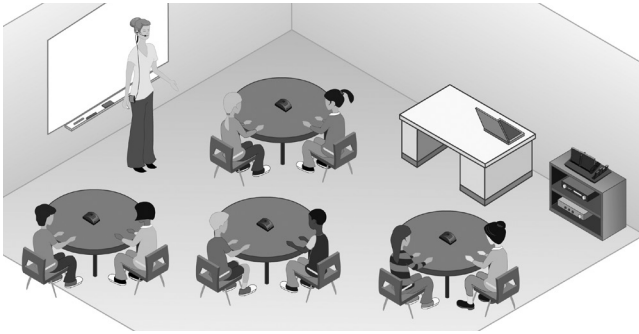

8. INTEGRATION WITH MULTIMEDIA AUDIO SOURCE

The FLEXCAT base station has two audio input connections for integration with other classroom technology. When connected, the teacher can send that audio directly to the students' desktop, ensuring clarity and quality of audio.

- Using an optional 3.5mm stereo audio cable, plug the computer, DVD player, MP3 or other device into the FLEXCAT base station.

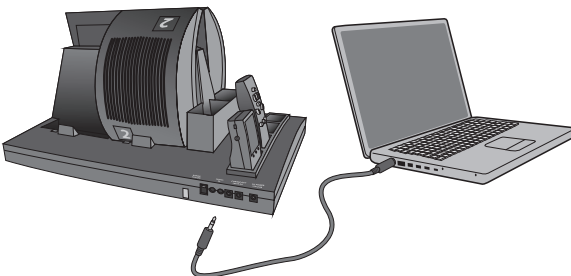

6. Safety & Specifications

5. Maintenance & Troubleshooting

4. Additional Information

3. Daily Operation

2. Initial Set-up

1. Overview

SECTION 3:

DAILY OPERATING INSTRUCTIONS

1. OPERATING THE FLEXCAT

1. **Remove the desktop speakers from the charger and place them on the group tables.**
 - The speakers will automatically power on when the switch is left in the on position.
 - Note the location of the speaker numbers.
2. **Remove the belt-pack and headset and put them on.**
 - The belt-pack will automatically power on when the switch is left in the on position.
 - The blue LED will turn on after a few seconds to indicate the unit is powered on and linked with the base station
 - The belt-pack can be worn anywhere that is comfortable for the teacher. It can be:
 - Clipped to a belt around
 - Clipped to the outside of a pocket
 - Placed inside a pocket
 - Place the headset on. It is designed to be worn over the ear as shown below:
3. **Remove the remote and begin instruction. Use the remote to:**
 - Address the whole class
 - Address small groups
 - Monitor (listen only) small groups
 - Activate student group sharing
4. **Return the components to the base station for nightly recharging:**
 - Place all components in their respective charging slots
 - Desktop Speaker: insert with battery contact facing down.
 - Remote(s) and Belt-pack(s): the four small slots are interchangeable
 - The charging LED's will turn RED to indicate charging.
 - The units will fully charge overnight.
 - The LED's will turn GREEN to indicate charging is complete.

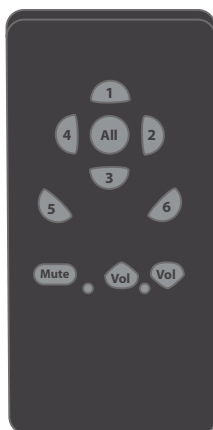

Using the remote:

Function	Command	Description
Whole Class Instruction	Press ALL	Sends the teachers voice to all desktop speakers at once.
Small Group Instruction	Press #1-4	Activates a 2-way audio connection to a small group. The teacher can address and listen to that group simultaneously.
Small Group Monitoring	Press MUTE, then #1-4	Mutes the teacher's microphone while allowing the teacher to listen in on group conversations. The speaker # button will turn RED.
Student Group Sharing	Press ALL, then press and hold #1-4	Allows one student group to address all other students for presentations and sharing. Both the ALL and station # buttons will light.
Disconnect	Press activated function again	This disconnects the transmission and turns any audio off. The LED for the selected function will turn off.
Teacher ear piece volume	Press Vol UP/DOWN arrows.	Turns the volume to the teacher's ear piece up or down. There is an audible tone in the ear when pressing.

SECTION 4:

ADDITIONAL OPERATION INFORMATION

1. TIPS AND TRICKS TO SUCCESSFUL USE

Determining optimum placement of the group speakers

- Group speakers should be placed in the approximate center of the group
- They can be placed on the center of a table or on the floor where the students are sitting.
- The microphone is designed to pick up students in a 360 degree radius, so it also operates best when in the middle of a group.

Determining proper volume levels

- This system is not designed to make the teachers voice louder, but to distribute it appropriately so it is heard clearly by the selected group of students.
- The group speakers are designed to be used independently, so turning the volume up too loud can result in bleed-over to another group.
- Typical volume levels at a group speaker are less than half of the maximum setting – approximately 10-11:00 on the dial.
- It should be loud enough that students in the desired group hear you as though you were speaking directly to them at a distance of 3 feet.

Managing equipment and charging

- Leave all components in the on position. When you place them on the charger, they will automatically power down to charge. When you remove them from the charger to start the day, they will automatically power back up.
- Assign students to manage the charging of the group speakers. Have one assigned student remove it from the charger to start the day and place it back on the charger at the end of the day.

2. MULTIMEDIA AUDIO INTEGRATION

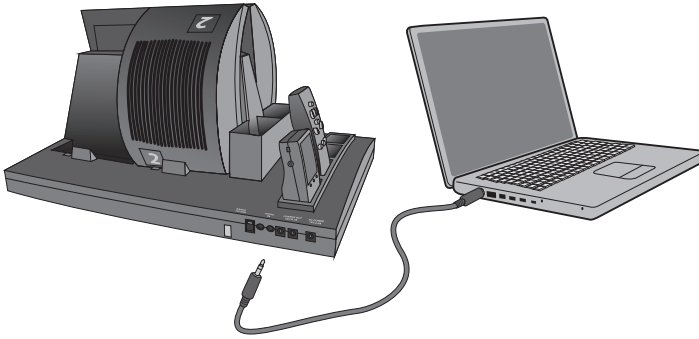

1. **Connect an audio cable from your computer (or other device) into one of the audio inputs connections on the base station.**
2. **Select "ALL" or "SPEAKER # 1-6" on the teacher remote.**
3. **Play the audio file on the computer, adjusting the volume on the computer as needed.**
4. **Directing audio to the Students:**
 - Use the remote to direct that audio to all students or a selected group (1-6)
 - NOTE: the teacher's voice will also be broadcast to whichever group the multimedia is sent to. Press MUTE on the remote if you only wish the children to hear the audio file.

6. Safety & Specifications

5. Maintenance & Troubleshooting

4. Additional Information

3. Daily Operation

2. Initial Set-up

1. Overview

2. MULTIMEDIA AUDIO INTEGRATION

CONT'D

5. Quick connection of multimedia to belt-pack

- For a temporary connection to a portable audio device like an (iPod, MP3 player, etc.) connect the audio device into the audio input on the teacher belt-pack.
- Select "ALL" or "SPEAKER # 1-6" on the teacher remote.
- Play the audio file on the computer, adjusting the volume on the computer as needed.
- Directing audio to the Students:
- Use the remote to direct that audio to all students or a selected group (1-6)
- **NOTE:** the teacher headset can remain plugged in and can operate simultaneously to the selected group speaker(s).
- **TIP:** if you have a team-teaching system (2 belt-packs and 2 remotes) you can send audio to one group (using Teacher 2 belt-pack) while talking to another group.

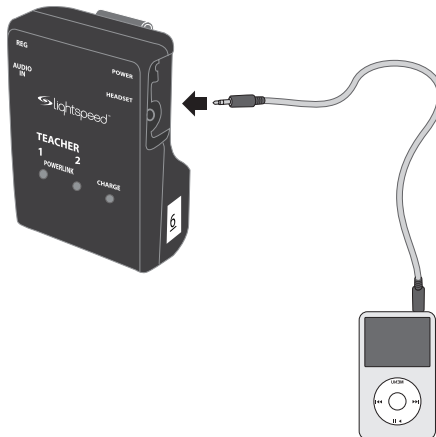

3. CONNECTION TO ASSISTIVE LISTENING DEVICES

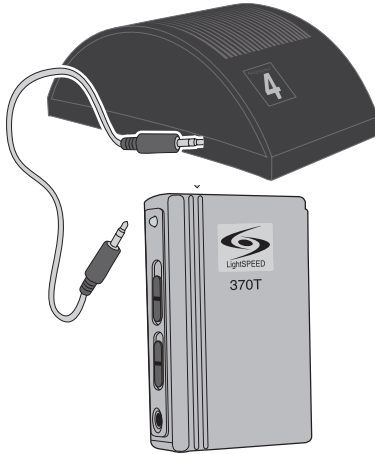

Students with assistive listening devices (ALD) can connect directly into the student group speaker to ensure they can clearly hear the teacher. This eliminates the teacher's need to wear separate transmitters and microphones.

1. Turn the ALD volume control on the group speaker all the way down.
2. Determine the size and type of audio input jack on the device as many manufacturers' products differ in connector size and shape.
3. Connect a patch cable from the ALD's microphone or AUX input jack to the "ALD OUT" connection on the group speaker.
4. With the ALD device set to its maximum volume level, slowly turn up the group speaker ALD volume control until the desired level for the student is reached.

4. USING OPTIONAL SPEAKERS #5-6

Although the standard FLEXCAT includes 4 group speakers, it is can to operate with up to 6 group speakers! The additional speakers can be purchased together with the main system or can be added down the road.

1. Operation

- If speakers #5-6 are purchased together with the original system, they will already be paired together and operate just as speakers #1-4 do.
- To select the speakers, simple press the #5-6 buttons on the remote. (See Section 3 for daily operation instructions).
- If the speakers were purchased at a separate time from the rest of the system, they will need to be linked to the base station. Please refer to the Group Speaker Registration Process on page ____.

2. Charging

- Group speakers #5-6 charge via cable connected to the base station.
- Connect the included charging cable(s) to the CHARGING OUTPUT jack(s) on the base station.
- Connect the other end of the jack to the CHARGE input jack on the group speaker.
- The charging light on the group speaker will turn RED to indicate charging. It will turn GREEN to indicate the unit is fully charged.

SECTION 5:

MAINTENANCE & TROUBLESHOOTING

REGISTRATION OF REPLACEMENT OR ADDITIONAL EQUIPMENT

In order for all system components to operate and communicate with one another, they must be registered to the base station. When purchased as a complete system, all components will be pre-registered and ready for use, so there is no need to manually register anything.

In the event a component needs to be replaced or an additional component is purchased down the road, it will need to be registered following the step by step instructions below.

- Start with all FLEXCAT system components powered down (in the charger or switched OFF).
- Turn on the Base Station.
- Remove the Belt-Pack(s) from the charger and ensure they are powered on.
- Remove each group speaker from the charger and ensure they are powered on.
- Wait for the "Ready" signal from all components as indicated by the following:
 - The Belt-Pack(s) will have a solid blue Teacher 1/2 LED lighted.
 - The green "Ready" LED on the bottom of each speaker will be lighted.
 - Press the ALL key on a Remote. The Base Station LINK LEDs will light for each speaker and each Belt-Pack that is already registered.
 - The link light for the speaker you are adding should not be lit.
- Proceed to the instructions for the appropriate component

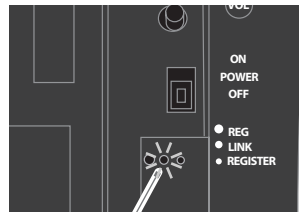
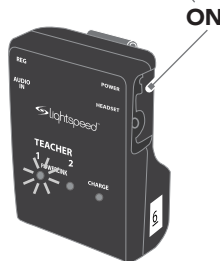
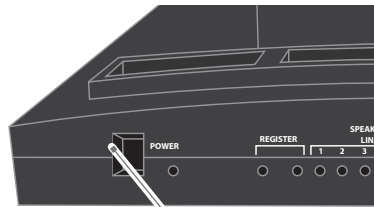

READY

GROUP SPEAKER REGISTRATION PROCESS

1. Turn on the new group speaker.

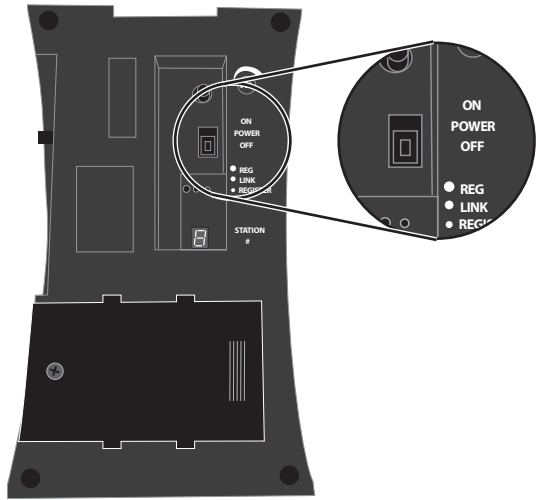

2. Press the Group Speaker Registration button on the Base Station. The yellow LED on the Base Station will start flashing.

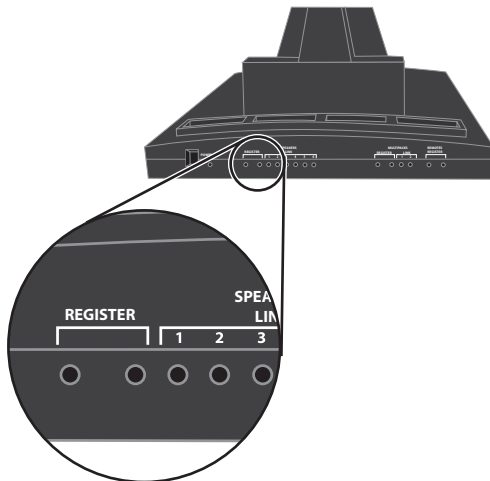

GROUP SPEAKER REGISTRATION CONT'D

- Press the registration button on the group speaker. The yellow registration LED on the new speaker should start flashing.

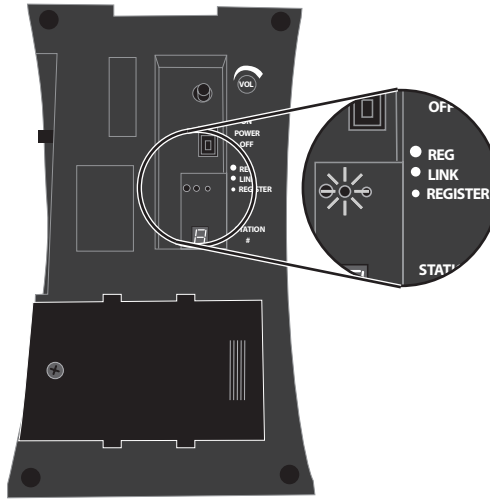

- Wait for the yellow speaker registration LED on the Base Station to change to a steady yellow.

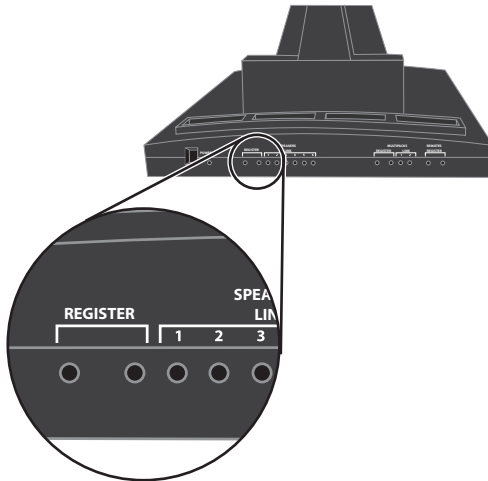

6. Safety & Specifications

5. Maintenance & Troubleshooting

4. Additional Information

3. Daily Operation

2. Initial Set-up

1. Overview

GROUP SPEAKER REGISTRATION CONT'D

- Wait for the yellow registration LED on the new group speaker to change to a steady yellow. A new speaker ID number will be shown on the seven segment display.

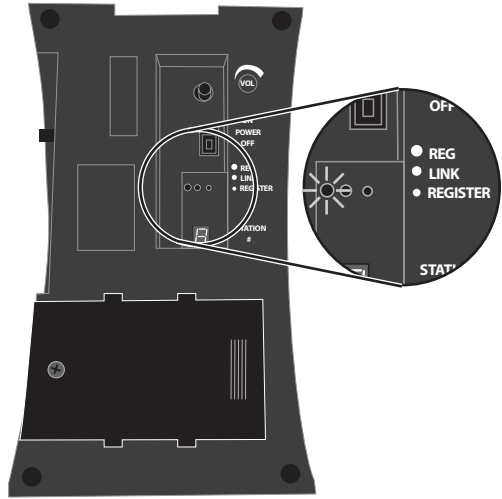

- The registration has failed if either of the registration LEDs do not change to a steady yellow and instead start to flash rapidly.
- If the registration fails repeat the steps 2 through 5.

BELT-PACK REGISTRATION

1. Turn on the new Belt-Pack.
2. Press the Belt-Pack registration button on the Base Station. The yellow Belt-Pack registration LED on the Base Station should start flashing.
3. Press the Belt-Pack registration button on the new Belt-Pack. Both of the blue Belt-Pack registration LEDs on the new Belt-Pack should start flashing alternately.
4. Wait for the yellow Belt-Pack registration LED on the Base Station to change to a steady yellow.
5. Wait for the blue Belt-Pack registration LEDs on the new Belt-Pack to settle on a single steady blue LED.
6. The registration has failed if any of the registration LEDs start to flash rapidly.
7. If the registration fails repeat the steps 2 through 5.

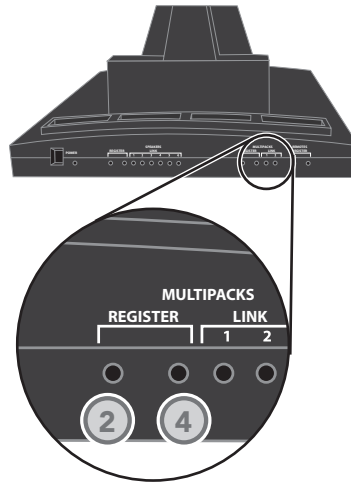
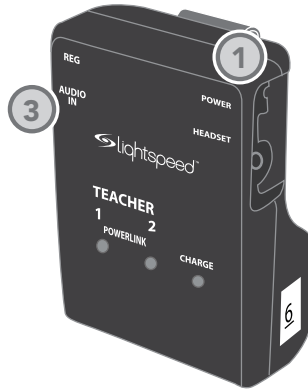

6. Safety & Specifications

5. Maintenance & Troubleshooting

4. Additional Information

3. Daily Operation

2. Initial Set-up

1. Overview

REMOTE REGISTRATION

1. Make sure that the Remote is adequately charged enough to be operating.
2. Remove the battery cover.
3. Be sure that the Teacher Select switch is in the proper position.
4. Turn on Base Station if it is not already on.
5. Press the Remote Pairing button on the Base Station and be sure that the yellow pairing LED is lighted.
6. Press the Remote Pairing button on the Remote and be sure that the green pairing LED is lighted.

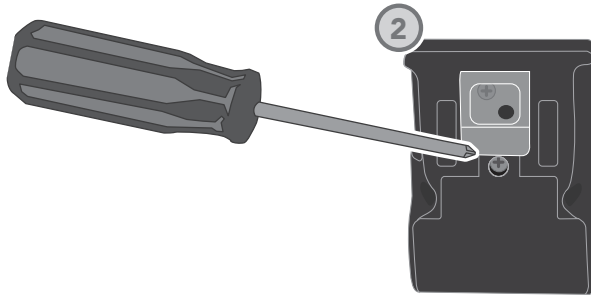

INSIDE BELTPACK

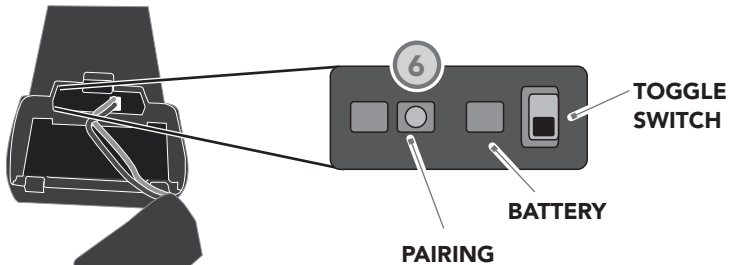

REMOTE REGISTRATION CONT'D

7. Wait for both the yellow and green pairing LEDs to turn off simultaneously, typically after about 5 seconds.
8. If the pairing LEDs turn off after 30 seconds then the Remote did not pair to the Base Station.
9. Press the ALL button on the remote – the button will light indicating the remote is registered.
10. If the pairing fails, repeat steps 5 through 7.
11. Replace the battery cover when completed.

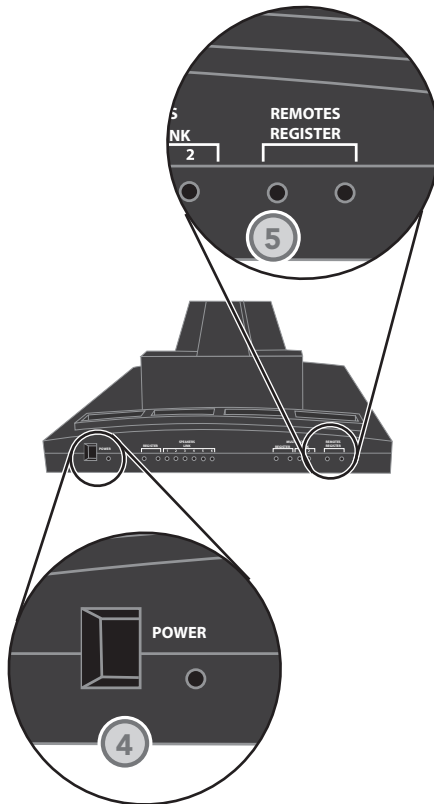

BATTERY REPLACEMENT

Overview of batteries

The group speaker, teacher belt-pack and remote contain rechargeable battery packs that require daily charging. The battery packs are warranted for 1-year but have a useful life of about 2+ years before they should be replaced. The battery packs must be purchased directly from Lightspeed, but can easily be installed by the user.

Replacement of battery pack in group speaker

1. Use a screw-driver to remove the screw and slide the battery door open.
2. Slide the battery pack out and disconnect the cable.
3. Take the new battery pack, connect the cable as shown and insert the battery pack into the compartment.
4. Slide the cover back on and tighten the screw to secure the door.

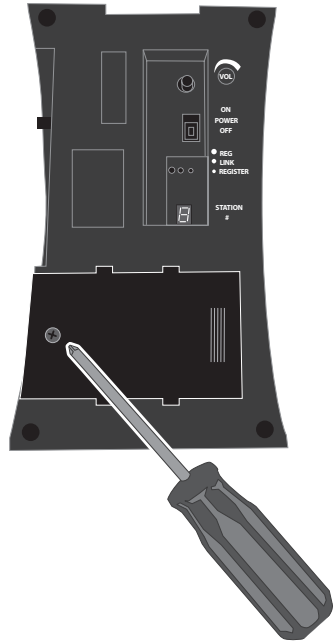

BATTERY REPLACEMENT CONT'D

Replacement of battery pack in belt-pack

1. Use a screw-driver to remove the screw and the slide the battery door open.

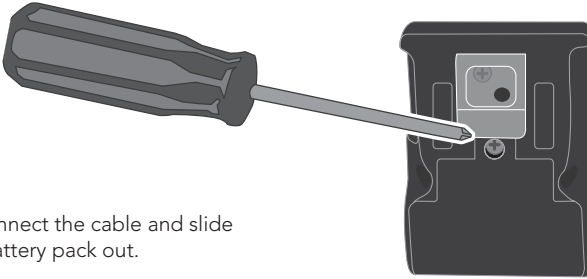

2. Disconnect the cable and slide the battery pack out.
3. Take the new battery pack, connect the cable as shown and insert the battery pack into the compartment.
4. Slide the cover back on and tighten the screw to secure the door.

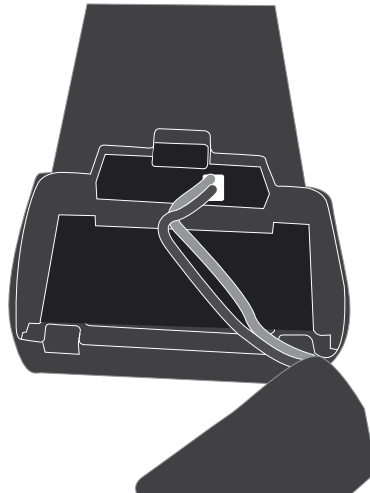

BATTERY REPLACEMENT CONT'D

Replacement of battery pack in remote

1. Use a screw-driver to remove the screw and slide the battery door open.
2. Disconnect the cable and slide the battery pack out.
3. Take the new battery pack, connect the cable as shown and insert the battery pack into the compartment.
4. Slide the cover back on and tighten the screw to secure the door.

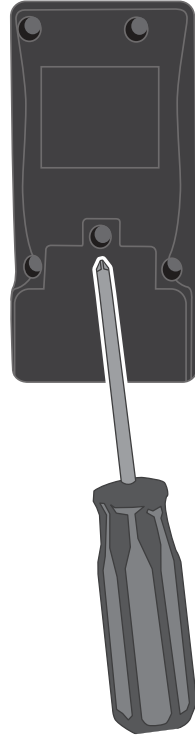

TROUBLESHOOTING

Note: Most problems are directly related to low battery power. Please run through the “Battery Check” items first. For remaining troubleshooting, use known good, fully-charged batteries.

ALL PROBLEMS: most problems are related to low battery power.

SOLUTION: check the batteries and ensure proper charging.

- Confirm batteries are properly charged each night.
- When placing a component in a charger, ensure the RED charging LED turns on. The GREEN charging light will turn on when a full charge is reached.
- Regardless of battery life, the RED light will turn on for 20-30 minutes to check status. When battery is full, the light will turn GREEN at some time after that.
- Fully charged batteries will operate properly throughout a full school day for a period of at least 1-2 years. If the batteries are older, they likely need to be replaced.

PROBLEM: No audio from group speaker.

SOLUTION: follow these steps to isolate and eliminate the problem.

- Ensure group speaker power is on.
- Turn the speaker on.
- Ensure headset is properly connected into the belt-pack
- Ensure the mute button on the

remote is not turned on. The mute button should be un-lighted and the ALL and speaker number buttons selected should be green.

- Ensure the group speaker volume is set to a nominal level. If it is turned all the way down, there will be no audio.
- Ensure group speaker is properly linked as indicated by the “READY” LED on the bottom.
 - Try turning the speaker off, then on again and wait up to 30 seconds for it to properly link.
- Ensure teacher belt-pack is on and “READY” for use as indicated by a solid blue light.
 - Turn the belt-pack on and wait up to 30 seconds for it to properly link.
- Ensure teacher remote is properly registered.
 - Press the ALL button. The GREEN LED should light.
 - If it doesn’t light, make sure the belt-pack and group speaker are both “READY.”
 - Ensure the batteries are fully charged. If the RED battery low LED is on, it can experience intermittent operation.

TROUBLESHOOTING CONT'D

PROBLEM: Remote does not light or activate any group speakers

SOLUTION:

- Ensure the batteries have a charge. They should be charged nightly.
- Try pressing the MUTE button.
 - If this button lights, the remote has a battery charge.
 - If this button doesn't light, the battery is dead.
- Ensure the base station is powered on.
- Ensure at least one group speaker and at least one belt-pack are "READY" for operation.
 - Once verified, try pressing the ALL button on the remote. This will activate any speaker and any microphone that is linked up.
- If using a team teaching configuration, ensure you are using the correct remote with the correct belt-pack (Teacher 1 with Teacher 1)
 - Try using the second remote to verify.
 - If you are still unsure, open the remote's battery door and observe the position of the Teacher 1/Teacher 2 switch.
- It is possible the remote is not properly registered to work with the base station. Please refer to the registration process to reconnect.

PROBLEM: Belt-pack does not indicate a "READY" signal

SOLUTION:

- Ensure the batteries have a charge. They should be charged nightly.
- Ensure the power switch is turned on. Once turned on, the LED should begin blinking.
- Ensure the base station is turned on. If the base station is power off, the belt-pack has nothing to link to.
- Power the unit off, then on again after a few seconds. Wait for up to 30 seconds for the blue LED to turn solid, indicating READY for operation.
- If no READY signal is indicated, it is possible the belt-pack is not properly registered to work with the base station. Please refer to the registration process to reconnect.

SECTION 6:

SAFETY & SPECIFICATIONS

Lightspeed's FLEXCAT Group Audio System is guaranteed against malfunction due to defects in materials and workmanship for a period of THREE (3) YEARS, beginning at the date of the purchase invoice. If such malfunction occurs, the product will be repaired or replaced (at Lightspeed's option) without charge during the warranty period.

Lightspeed's Warranty Exchange Program applies to FLEXCAT systems within the three (3) year warranty period. If an system component has an issue that requires service, a refurbished replacement will immediately be sent to the customer to minimize downtime. Customers will receive the exchange product(s) or component(s) within 2-3 days. A prepaid return label will be included with exchanged products so original malfunctioned equipment can be returned to Lightspeed. Any exchanged equipment will remain covered under the original three (3) year warranty.

1. Warranty on primary components including: base station, group speakers, belt-pack and remote is THREE (3) YEARS.
2. Warranty on headset microphones and Lightspeed NiMH rechargeable battery packs is one (1) year.
3. Prepaid shipping label provided by Lightspeed for warranty repairs within the U.S. Customers outside the U.S. should refer to the Lightspeed website (www.lightspeed-tek.com) for warranty repair instructions.
4. Warranty does not extend to finish, appearance items, or malfunctions due to abuse or operation other than specified conditions, nor does it extend to incidental or consequential damages. Repair by other than Lightspeed or its authorized service agencies will void this guarantee. Information on authorized service agencies is available from Lightspeed Technologies, Inc.

6. Safety & Specifications

5. Maintenance & Troubleshooting

4. Additional Information

3. Daily Operation

2. Initial Set-up

1. Overview

Our Service Department (800.732.8999, 5 a.m. – 5 p.m., PST) will handle all your repair/replacement needs.

SAFETY WARNINGS AND CERTIFICATIONS

6. Safety & Specifications

5. Maintenance & Troubleshooting

4. Additional Information

3. Daily Operation

2. Initial Set-up

1. Overview



CAUTION
RISK OF ELECTRICAL SHOCK
DO NOT OPEN



THIS PRODUCT MUST BE INSTALLED IN ACCORDANCE WITH THE APPLICABLE INSTALLATION CODE BY A PERSON FAMILIAR WITH THE CONSTRUCTION AND OPERATION OF THE PRODUCT AND THE HAZARDS INVOLVED.

CERTIFICATIONS



Lightspeed Technologies launched a formal product recycle program in Europe that complies with the European Union Directive 2002/96/EC on Waste Electrical and Electronic Equipment ("WEEE Directive"). Please visit our website at www.Lightspeed-tek.com for more information.



This product is manufactured using lead-free processes and is free of other materials harmful to the environment. It conforms to the most stringent new European guidelines for consumer products (RoHS).

This device complies with part 15 of the FCC Rules. Operation is subject to the following two conditions: (1) This device may not cause harmful interference, and (2) this device must accept any interference received, including interference that may cause undesired operation.

WARNING: Changes or modifications to this equipment not expressly approved by the party responsible for compliance could void the user's authority to operate the equipment.

NOTE: This equipment has been tested and found to comply with the limits for a Class B digital device, pursuant to Part 15 of the FCC Rules. These limits are designed to provide reasonable protection against harmful interference in a residential installation. This equipment generates, uses and can radiate radio frequency energy and, if not installed and used in accordance with the instructions, may cause harmful interference to radio communications.

However, there is no guarantee that interference will not occur in a particular installation. If this equipment does cause harmful interference to radio or television reception, which can be determined by turning the equipment off and on, the user is encouraged to try to correct the interference by one or more of the following measures:

- Reorient or relocate the receiving antenna.
- Increase the separation between the equipment and receiver.
- Connect the equipment into an outlet on a circuit different from that to which the receiver is connected.
- Consult the dealer or an experienced radio/TV technician for help.

CAUTION: To maintain the compliance with the FCC's RF exposure guideline, place the FLEXCAT Charging Base and FLEXCAT Student Group Speaker at least 20 cm from nearby persons.

For body worn operation, the FLEXCAT belt-pack has been tested and meets the FCC RF exposure guidelines when used with the Lightspeed accessories supplied or designated for this product. Use of other accessories may not ensure compliance with FCC RF exposure guidelines.

**This Class B digital apparatus complies with Canadian ICES-003.
Cet appareil numérique de la classe B est conforme à la norme NMB-003 du Canada.**

SYSTEM SPECIFICATIONS

BASE STATION

DC Power Input:	16V / 2.0A
Cradle Charging:	1-4 group speakers; 1-2 teacher belt-packs; 1-2 handheld remotes
DC Charge out:	16V / 0.3A for 1-2 additional group speakers
Audio Inputs:	3.5mm stereo x2
Wireless communication:	DECT 1.9 GHz wideband for audio connections; RF4CE for control signals
Power switch with LED Indicator	
Audio Link indicators:	6 LED for link to group speakers 1-6; 2 LED for link to teacher belt-packs 1-2
Device Registration: push button for speaker(s), belt-pack(s), and remote(s)	2.06/2.54; 3.2/3.7 MHz
Dimensions (L x W x H):	15.75" x 12" x 9.2"

GROUP SPEAKERS (1-6)

Battery Power:	12V NiMH battery pack
Audio output power:	5 Watts per speaker
Integrated Speaker:	2" balanced mode radiator (BMR)
Integrated Microphone:	omni-directional electret
Wireless communication:	DECT 1.9 GHz wideband
Cradle charging:	2 contacts for cradle charging
DC charging input:	16V / 0.3A for alternate charging cable
Audio output: Registration:	3.5mm and USB push button and LED for registration with base station
Dimensions (L x W x H):	8.5" x 5.0" x 3.5"

TEACHER BELT-PACK (1-2):

Battery Power:	2.5V NiMH battery pack
Cradle charging:	2 contacts for cradle charging
Wireless communication:	DECT 1.9 GHz wideband
Headset Input:	2.5mm TRS
Audio Input:	3.5mm stereo
Power:	on/off switch
Registration:	push button and LED for registration with base station
Dimensions (L x W x H):	2.75" x 2.0" x 1.0"

6. Safety & Specifications

5. Maintenance & Troubleshooting

4. Additional Information

3. Daily Operation

2. Initial Set-up

1. Overview

SYSTEM SPECIFICATIONS CONT'D

HANDHELD REMOTE (1-2)

Battery Power:	2.5V NiMH battery pack
Cradle charging:	2 contacts for cradle charging
Wireless communication:	RF4CE
Controls:	Group speaker selection 1-6; All speaker selection; Microphone mute; Earpiece volume
Registration:	push button and LED for registration with base station
Dimensions (L x W x H):	4.25" x 2.0" x 1.0"

HEADSET

Description:	under-the-ear headset with boom microphone and in ear piece
Connector:	2.5mm
Microphone:	wind smart voice tube
Controls:	microphone mute and earpiece volume up/down



LIGHTSPEED TECHNOLOGIES

11509 SW HERMAN ROAD / TUALATIN, OR 97062

TOLL FREE: 800.732.8999 / PHONE: 503.684.5538 / FAX: 503.684.3197

LIGHTSPEED-TEK.COM