

Test Report

Test Report Number EOTEL004
Applied Standard(s) FCC Part15 Subpart C, ANSI C63.4-2003
Date of Issue 6th December, 2013
Testing Laboratory Address Astronaut Noborito Laboratory
294 Noborito, Tama-ku Kawasaki-shi, Kanagawa, 214-0014 Japan
Test Date(s) 29th 30th 31th October, 2013
Product Name IC Card Reader/Writer
Model Number TR63024 (E)
Serial Number ES27
Applicant (Client) Address TOPPAN FORMS CO., LTD.
1-7-3 Higashi Shimbashi, Minato-ku, Tokyo 105-8311, Japan
Manufacturer Address UKC Electronics Corporation
Gate City Ohsaki, East tower, 1-11-2 Osaki, Shinagawa-ku, Tokyo
141-0032, Japan

Test Result

The test result for the electromagnetic compatibility tests as described in the section 1 to 2 and in this page was:

Pass

Tested by: Akihide Nano
Akihide Nano
Test Engineer

Approved by: Koji Imai
Koji Imai
Testing Group Leader

Checked box () indicates that the listed condition, standard or equipment is applicable for this Report.
Blank box () indicates that the listed condition, standard or equipment is not applicable for this Report.
It is not allowed to copy this report, except in full, without written permission of the test laboratory.
Test results of this report refer only to the EUT tested here.

	Page
Cover Page.....	1
Table of Contents.....	2
1. Summary	3
1.1 Terms and definitions.....	3
1.2 Standard(s) and Result	3
1.3 Deviations from Standard(s).....	4
1.4 Antenna Requirements	4
1.5 Modular transmitter Requirements.....	4
2. Equipment Under Test (EUT).....	5
2.1 General Descriptions	5
2.2 Detailed Descriptions	5
2.3 Operation Mode(s) of the EUT for EMC the Test(s)	5
2.4 Labeling Requirements	6
2.5 Measurement Condition.....	6
3. Test Data	8
3.1 Test specification	8
3.2 20dB Bandwidth.....	9
3.3 Frequency Stability Tolerance	10
3.4 In-Band Radiated Spurious Emission	11
3.5 Out-of-Band Radiated Spurious Emission	12
3.6 Line Conducted Measurement Data	14
4. Photographs	16
4.1 Photographs of Test setup.....	16
5. Test facility.....	19
5.1 Test Instruments	19
5.2 Test equipment	19

1. Summary

1.1 Terms and definitions

AV
Average

DoC
Declaration of Conformity

EUT
Equipment Under Test

QP
Quasi-peak

1.2 Standard(s) and Result

Applied Standard(s)	Normative Reference(s)	Test Limit	FCC Part	Result	Reference Clause No.
FCC Part15 Subpart C	20dB Bandwidth	within 13.110 - 14.010MHz	15.215(c)	Pass	3.2
	Frequency Stability Tolerance	±0.01% of Operating Frequency	15.225(e)	Pass	3.3
	In-Band Emissions	15.848 μ V/m @30m 13.410 - 13.553 MHz	15.225 (a)(b)(c)	Pass	3.4
		334 μ V/m @30m 13.410 - 13.553 MHz 13.567 - 13.710 MHz			
		106 μ V/m @30m 13.110 - 13.410 MHz 13.710 - 14.010 MHz			
Out-of-Band Emissions	Emissions outside of the specified band (13.110 - 14.010 MHz) must meet the radiated limits detailed in 15.209	15.225(d), 15.209 15.205	Pass	3.5	
AC Conducted Emission 150 kHz - 30 MHz	< FCC 15.207 limits or RSS-Gen table 2 limits>	15.207	Pass	3.6	

Table1 Standard and result

1.3 Deviations from Standard(s)

There was no deviation from the standard.

1.4 Antenna Requirements

Excerpt from §15.203 of the FCC Rules/Regulations:

“An intentional radiator antenna shall be designed to ensure that no antenna other than that furnished by the responsible party can be used with the device. The use of a permanently attached antenna or of an antenna that uses a unique coupling to the intentional radiator shall be considered sufficient to comply with the provisions of this section.”

The antennas are permanently attached.

There are no provisions for connection to an external antenna

Conclusion:

The TOPPAN FORMS CO.,LTD. IC Card Reader/Writer FCC ID: ORKTR63024-E equipment complies with the requirement of §15.203.

1.5 Modular transmitter Requirements

Excerpt from §15.212 of the FCC Rules/Regulations:

“Single modular transmitters must meet the following requirements to obtain a modular transmitter approval.”

(i) The radio elements of the modular transmitter must have their own shielding. The physical crystal and tuning capacitors may be located external to the shielded radio elements.

(ii) The modular transmitter must have buffered modulation/data inputs (if such inputs are provided) to ensure that the module will comply with Part 15 requirements under conditions of excessive data rates or over-modulation.

(iii) The modular transmitter must comply with the antenna and transmission system requirements of Sections 15.203, 15.204(b) and 15.204(c). The antenna must either be permanently attached or employ a “unique” antenna coupler (at all connections between the module and the antenna, including the cable). The “professional installation” provision of Section 15.203 is not applicable to modules but can apply to limited modular approvals under paragraph (b) of this section.

(iv) The modular transmitter must be tested in a stand-alone configuration, i.e., the module must not be inside another device during testing for compliance with Part 15 requirements. Unless the transmitter module will be battery powered, it must comply with the AC line conducted requirements found in Section 15.207. AC or DC power lines and data input/output lines connected to the module must not contain ferrites, unless they will be marketed with the module (see Section 15.27(a)). The length of these lines shall be the length typical of actual use or, if that length is unknown, at least 10 centimeters to insure that there is no coupling between the case of the module and supporting equipment. Any accessories, peripherals, or support equipment connected to the module during testing shall be unmodified and commercially available (see Section 15.31(i)).

(v) The modular transmitter must be equipped with either a permanently affixed label or must be capable of electronically displaying its FCC identification number.

(vi) The modular transmitter must comply with any specific rules or operating requirements that ordinarily apply to a complete transmitter and the manufacturer must provide adequate instructions along with the module to explain any such requirements. A copy of these instructions must be included in the application for equipment authorization.

(vii) The modular transmitter must comply with any applicable RF exposure requirements in its final configuration.

2. Equipment Under Test (EUT)

2.1 General Descriptions

The TR63024 is a highly integrated IC Card Reader/Writer contactless communication at 13.56 MHz. It operates from a single +5 V supply DC, the upper interface allows you to select the UART or USB. Corresponding RF telecommunications standard corresponds to four kinds "ISO/IEC14443-A, B, JIS X 6319-4, ISO/IEC15693."

2.2 Detailed Descriptions

Product Name	IC Card Reader/Writer
Model Number	TR63024 (E)
Serial Number	ES27
Power Supply	USB bus power only (DC+5V)
Dimension	5mm(W) × 48mm(H) × 71mm(D)
Operating Frequency	13.56MHz
Equipment Category	Indoor equipment
Normal Placement	Table-top
Condition of the EUT	Prototype
FCC ID	ORKTR63024-E

Table2 Detailed Description

2.3 WORST-CASE CONFIGURATION AND MODE

(a) EUT axes

The fundamental was measured in three different orientations X, Y and Z to find worst-case orientation, and it was found that Y orientation is worst-case; therefore final testing for radiated emissions was performed with EUT in Y orientation with Cable.

(b) Communication standard

The EUT supports following 5 communication standards.

ISO14443 Type A
 ISO14443 Type B
 FeliCa 212kbps
 FeliCa 424kbps
 ISO15693

The fundamental level and spurious level were measured in 5 standards.
 The ISO14443 Type A was selected as a worst case of standard.

2.4 Labeling Requirements

Per 15.19; Docket 95-19

The label shall be permanently affixed at a conspicuous location on the device; instruction manual or pamphlet supplied to the user and be readily visible to the purchaser at the time of purchase. However, when the device is so small wherein placement of the label with specified statement is not practical, only the trade name and FCC ID must be displayed on the device per Section 15.19(b)(2). Please see attachment for FCC ID label and label location.

2.5 Measurement Condition

2.5.1 EUT Operation

The EUT was measured by transmitter mode continuously.

2.5.2 Configuration and Peripherals

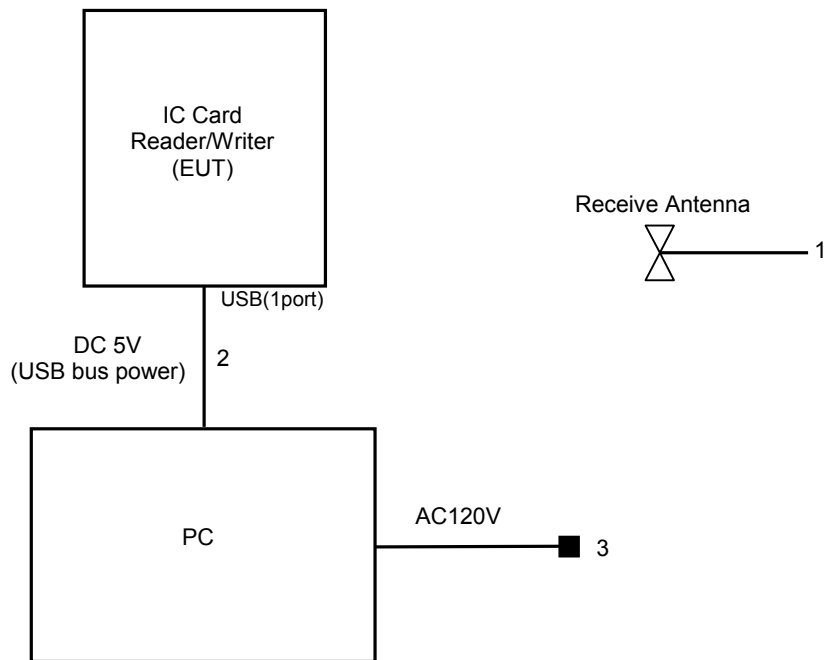

Figure 1 configuration and Peripherals

2.5.3 EUT

Mark	Description	Model number	Serial Number	FCC ID Code or DoC status	Manufacturer
1	IC Card Reader/Writer	TR63024 (E)	ES27	ORKTR63024-E	UKC Electronics Corporation

Table4 EUT

2.5.4 Peripheral Devices

Mark	Description	Model number	Serial Number	FCC ID Code or DoC status	Manufacturer
1	Personal computer	Vostro 3360	-	DoC	Dell

Table5 Peripheral Devices

2.5.5 Interconnecting Cables

Mark	Description	Length (m)	Shielded		Tested Port(s) (Note:1)	
			Cable	Connector	Applicable	Interface
1	Antenna cable	7.0	Shielded	Shielded	No	RF Signal
2	USB cable	1.5	None	None	No	DC Power, I/O Signal
3	Power cable	2.0	None	None	No	AC Power

Note1: Tested port(s) required for applicable standard(s).

Remarks: The length described here is the length of the cable typically used in the tests, but different length of the cable may be used in some tests to satisfy the requirements for the test.

Table6 Interconnecting Cables

3. Test Data

3.1 Test specification

Standard	FCC Part15 Subpart C 15.205 15.207 15.209 15.215 15.225, ANSI C63.4-2003	
Tested Frequency	13.56 MHz	
Test Date	29 th October 2013 – 31 th October 2013	
Test Location	Astronaut Noborito Laboratory Thermostatic chamber	
Test Engineer	Akihide Nano	
Temperature	21.2 °C – 24.0°C	
Humidity	54.2 % RH – 58.0% RH	
Power Supply		
Normal	DC5.0V	
High	DC5.75V	*1
Low	DC4.25V	*1
Tested Temperature		
Normal	+20 °C	
High	+60 °C	*1
Low	-20 °C	*1

Remark: *1 : Frequency Stability only.

Table7 Test specification

3.2 20dB Bandwidth

3.2.1 Test Result

Pass

3.2.2 Test Detail

The measurement was performed in the antenna height to gain the maximum of Electric field strength

3.2.3 Test data

Item	Limit	Result	UNIT
		20dB	
Lower	13.110	13.248	MHz
Upper	14.010	13.844	
Total	0.900	0.596	

Table8 20dB Bandwidth

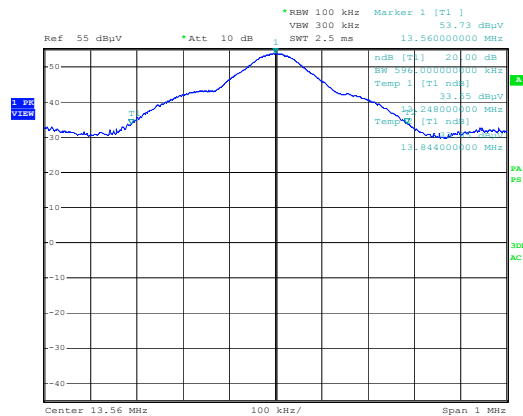

2_HANSO
Date: 30.OCT.2013 16:33:58

Figure 2 20dB Bandwidth Plot

3.3 Frequency Stability Tolerance

3.3.1 Test Result

Pass

3.3.2 Test Detail

The frequency stability of the transmitter is measured by:

1. Temperature: The temperature is varied from -20°C to +60°C using an environmental chamber.
2. Primary Supply Voltage: The primary supply voltage is varied from 85% to 115% of the voltage normally at the input to the device or at the power supply terminals if cables are not normally supplied.

The frequency tolerance of the carrier shall be maintained within $\pm 0.01\%$ of the operating Frequency

3.3.3 Test data

Operating Frequency: 13,560,000 Hz

Reference Voltage: DC5 V

Deviation Limit: ± 0.01 % = 1356Hz

Voltage (%)	Power Supply (V_DC)	Temp (°C)	Frequency (MHz)	Freq. Dev. (Hz)	Deviation (%)
100	5V	+20 (Ref)	13.5599503	-49.7	-0.00037
		-20	13.5599753	-24.7	-0.00018
		+60	13.5599517	-48.3	-0.00036
85	4.25V	+20	13.5599563	-43.7	-0.00032
115	5.75V	+20	13.5599577	-42.3	-0.00031

Table 9 Frequency Stability Tolerance

3.4 In-Band Radiated Spurious Emission

3.4.1 Test Result

Pass

3.4.2 Test Detail

Radiated emission testing was performed in the band 13.110 - 14.010 MHz.

3.4.3 Test data

Frequency (MHz)	Level (dB μ V)	Factor (dB)	Ant Pol. (H/V)	3m Field Strength (dB μ V/m)	30m Field Strength (dB μ V/m)	Limit (dB μ V/m)	Margin (dB)
13.562	53.4	16.8	H	70.2	50.2	84.0	33.8
13.454	42.3	16.8	H	59.1	39.1	50.5	11.4
13.349	37.5	16.8	H	54.3	24.3	40.5	16.2
13.562	50	16.8	V	66.8	46.8	84.0	37.2
13.668	36.9	16.8	V	53.7	33.7	50.5	16.8
13.349	34	16.8	V	50.8	30.8	40.5	9.7

Table 10 In-Band Radiated Spurious Emission

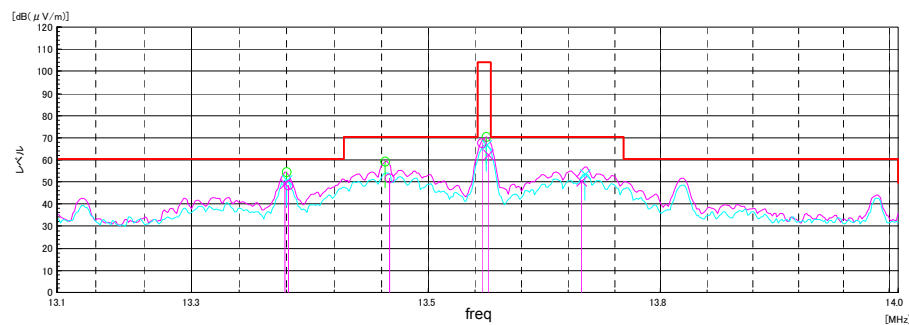

Figure 4 In-Band Radiated Spurious Emission Plot

Notes:

- All measurements were performed using a loop antenna. The antenna was positioned in three orthogonal positions (X front, Y side, Z top) and the position with the highest emission level was recorded. The EUT was positioned in three orthogonal planes to determine the orientation resulting in the worst case emissions.
- The EUT is supplied with nominal AC voltage. Measurements were performed at 3m and the data was extrapolated to the specified measurement distance of 30m using the square of an inverse linear distance extrapolation factor (40 dB/decade) as specified in §15.31(f)(2). Extrapolation Factor = $20 \log_{10}(30/3)^2 = 40$ [dB]
- All measurements were recorded using a spectrum analyzer employing a quasi-peak detector.
 Field Strength Level [dB μ V/m] = Analyzer Level [dB μ V] + Factor [dB/m].
 Factor [dB/m] = Antenna Factor [dBm] + Cable Loss [dB] - Extrapolation Factor [dB]
 Margin [dB] = Field Strength Level [dB μ V/m] - Limit [dB μ V/m]

3.5 Out-of-Band Radiated Spurious Emission

3.5.1 Test Result

Pass

3.5.2 Test Detail

The EUT was tested from 9 kHz up to the 140MHz excluding the band 13.110 - 14.010 MHz. All measurements up to 140 MHz were recorded with a spectrum analyzer employing a quasi-peak detector. All out-of-band emissions must not exceed the limits shown in the following table. A loop antenna was used to investigate emissions below 30 MHz.

The emission limits shown in the above table are based on measurements employing a CISPR quasi-peak detector except for the frequency bands 9-90kHz, 110-490kHz. Radiated emission limits in these bands are based on measurements employing an average detector.

Frequency (MHz)	Field Strength ($\mu\text{V/m}$)	Measured Distance (Meters)
0.009 - 0.490	2400/F (kHz)	300 *1
0.490 - 1.705	24000/F (kHz)	30 *2
1.705 - 30.00	30	30 *2
30.00 - 88.00	100	3
88.00 - 140.0	150	3

Table 11 Radiated Limits, Out-of-Band

3.5.3 Test data

Below 30MHz

Frequency (MHz)	Level (dB μV)	Factor (dB/m)	ANT Pol. (H/V)	3m Field Strength (dB $\mu\text{V/m}$)	Limit (dB $\mu\text{V/m}$)	Margin (dB)
0.018	35.6	19.6	V	55.2	87.9	32.7
0.044	34.2	17.4	V	51.6	86	34.4
1.574	25.9	16.3	V	42.2	50.6	8.4
0.052	35.9	17.1	H	53	85.4	32.4
0.085	33.1	16.2	H	49.3	83	33.7
29.547	1.9	16.8	H	18.7	49.5	30.8

Table 11 Below 30MHz Radiated Spurious Emission measurements, Out-of-Band

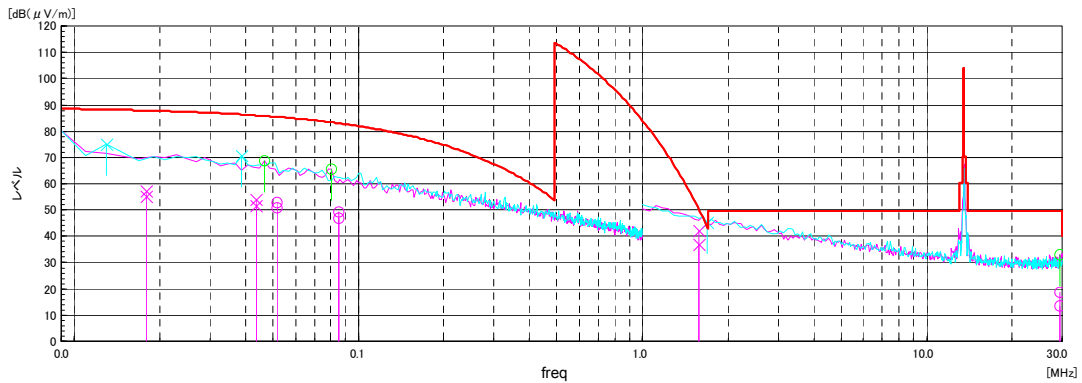

Figure 5 Below 30MHz Radiated Spurious Emission, Out-of-Band Plot

Above 30MHz

Frequency (MHz)	Level (dBμV)	Factor (dB/m)	Antenna Position (m)	ANT Pol. (H/V)	3m Field Strength (dBμV/m)	Limit (dBμV/m)	Margin (dB)
31.363	7	24.4	100	V	31.4	40	8.6
35.971	2.8	22.7	104	V	25.5	40	14.5
56.998	7.9	16.1	101	V	24	40	16
31.363	-1	25.5	363	H	24.5	40	15.5
135.002	6	21.6	208	H	27.6	43.5	15.9
141.019	5.5	22.3	218	H	27.8	43.5	15.7

Table 12 Above 30MHz Radiated Spurious Emission measurements, Out-of-Band

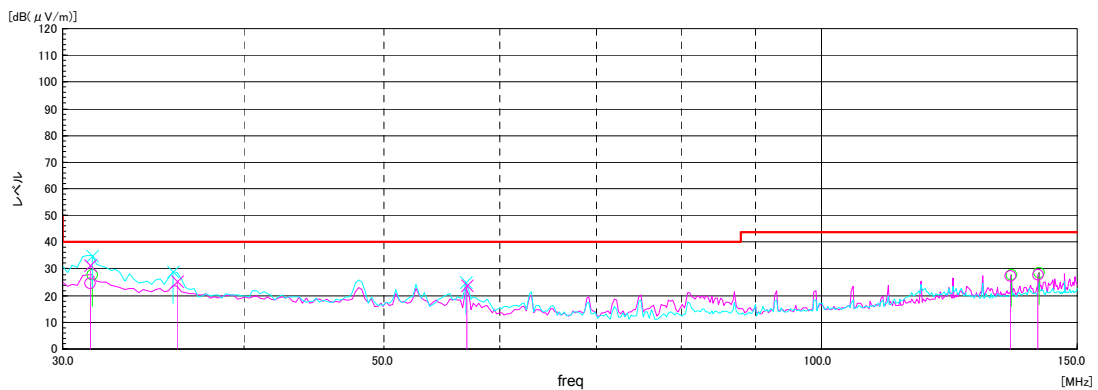

Figure 6 Above 30MHz Radiated Spurious Emission, Out-of-Band Plot

Notes:

- Both Vertical and Horizontal polarities of the receive antenna were evaluated with the worst case emissions being reported. Below 30 MHz the loop antenna was positioned in 3 orthogonal planes (X front, Y side, Z top) to determine the orientation resulting in the worst case emissions.
- Measurements were performed at 3m and the data was extrapolated to the specified measurement distance of 30m or 300m using the square of an inverse linear distance extrapolation factor (40 dB/decade) as specified in

$$\begin{aligned} \S 15.31(f)(2). \text{ Extrapolation Factor} &= 20 \log_{10}(300/3)^2 = 80 \text{ [dB]} \quad *1 \\ &= 20 \log_{10}(30/3)^2 = 40 \text{ [dB]} \quad *2 \end{aligned}$$

3. All measurements were recorded using a spectrum analyzer employing a quasi-peak detector for emissions below 140.0 MHz.
But quasi-peak detector except for the frequency bands 9-90 kHz and 110-490 kHz Radiated emission limits in these two bands are based on measurements employing an average detector.
Field Strength Level $_{[dB\mu V/m]} = \text{Analyzer Level}_{[dB\mu V]} + \text{Factor}_{[dB/m]}$.
Factor $_{[dB/m]} = \text{Antenna Factor}_{[dB/m]} + \text{Cable Loss}_{[dB]} + \text{Priamp Gain}_{[dB]} - \text{Extrapolation Factor}_{[dB]}$
Margin $_{[dB]} = \text{Field Strength Level}_{[dB\mu V/m]} - \text{Limit}_{[dB\mu V/m]}$
4. The EUT is supplied with nominal AC voltage .
5. The spectrum is measured from 9 kHz to the 10th harmonic and the worst-case emissions are reported.

3.6 Line Conducted Measurement Data

3.6.1 Test Result

Pass

3.6.2 Test Detail

Onto the AC power line on any frequency or frequencies within the band 150 kHz to 30 MHz shall not exceed the limits in the following table, as measured using a 50 μ H/50 ohms line impedance stabilization network (LISN).

3.6.3 Test data

Frequency [MHz]	Line [A/B]	Factor [dB]	Level[dB μ V]		Result[dB μ V]		Limit[dB μ V]		Margin[dB]	
			QP	AV	QP	AV	QP	AV	QP	AV
0.15315	A	9.8	42.1	35.5	51.9	45.3	65.8	55.8	13.9	10.5
0.45124	A	10.2	32.7	27.2	42.9	37.4	56.9	46.9	14	9.5
13.5599	A	10.2	37.2	37.4	47.4	47.6	60	50	12.6	2.4
1.0564	A	9.9	11.8	5.7	21.7	15.6	56	46	34.3	30.4
1.55107	A	9.9	12.6	7.4	22.5	17.3	56	46	33.5	28.7
1.06091	A	9.9	12.8	5.4	22.7	15.3	56	46	33.3	30.7
0.45503	B	10.2	32.4	27	42.6	37.2	56.8	46.8	14.2	9.6
0.5186	B	10.1	19.5	10.6	29.6	20.7	56	46	26.4	25.3
1.00919	B	10	14.5	9.4	24.5	19.4	56	46	31.5	26.6
1.14321	B	9.9	16.8	11.6	26.7	21.5	56	46	29.3	24.5
1.61526	B	9.9	15.9	10.8	25.8	20.7	56	46	30.2	25.3

Table 13 Line-Conducted Test Data

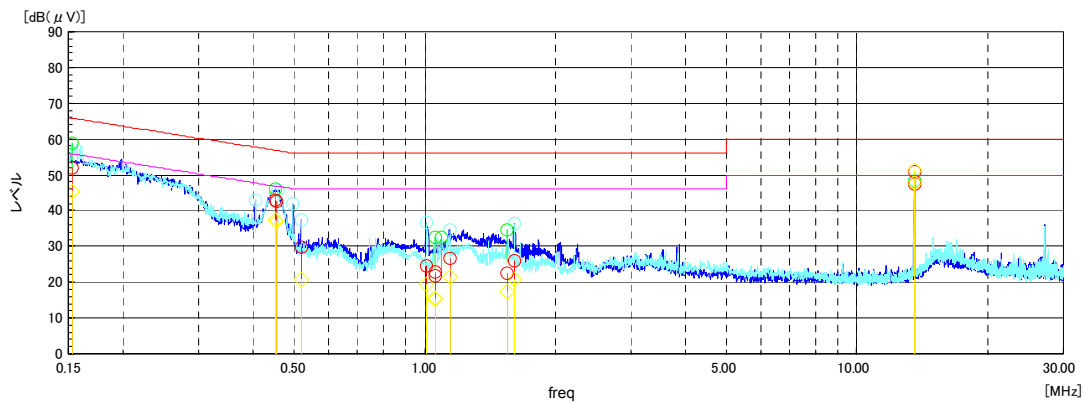

Figure 7 Line-Conducted Test Plot

Note:

1. All modes of operation were investigated and the worst-case emissions are reported.
 The limit for Class B device(s) from 150 kHz to 30 MHz are specified in section 15.207 of the Title 47 CFR.
 Line A = Phase; Line B = Neutral
 Factor (dB) = Cable loss (dB) + LISN insertion factor (dB)
 Result (dBμV) = Level (dBμV) + Factor (dB)
 Margin (dB) = Limit (dBμV) - Result (dBμV)
 Traces shown in plot are made using a peak detector.

2. 13.56 MHz is the fundamental signal and it is excluded from this data.

4. Photographs

4.1 Photographs of Test Setup



**Photo1 Test setup for below 30 MHz
(Front)**

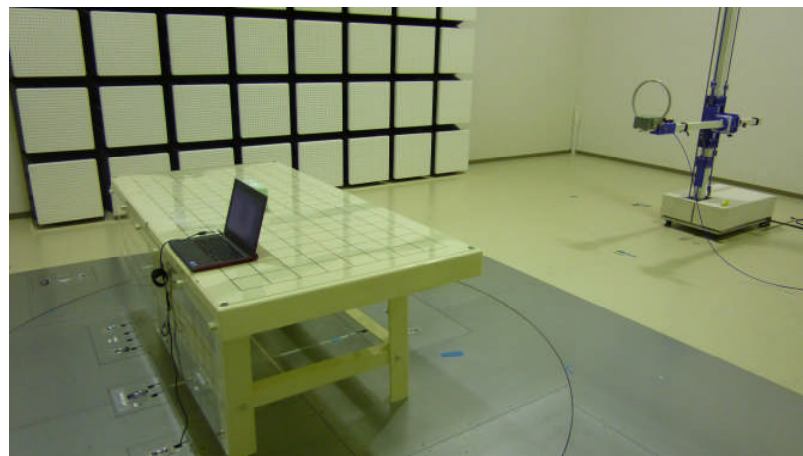

**Photo2 Test setup for below 30 MHz
(Back)**

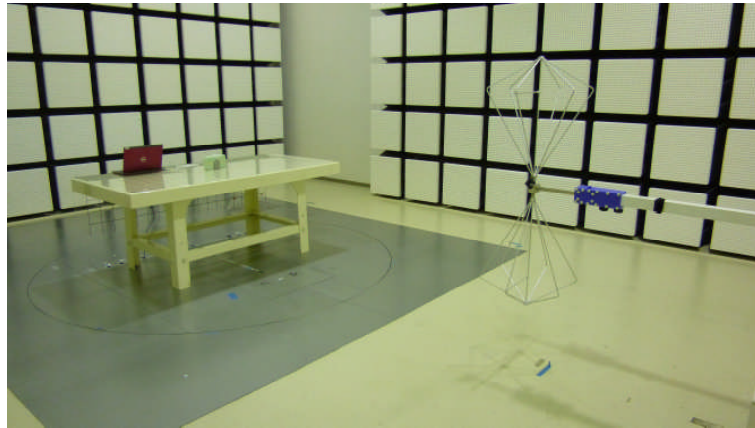

**Photo3 Test setup for above 30 MHz
(Front)**

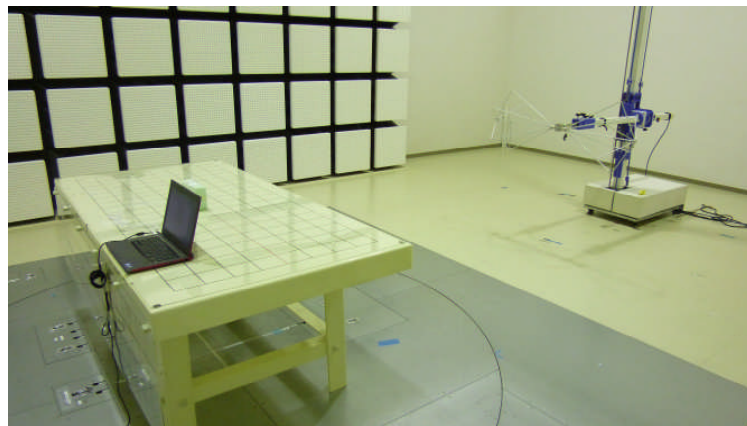

**Photo4 Test setup for above 30 MHz
(Back)**

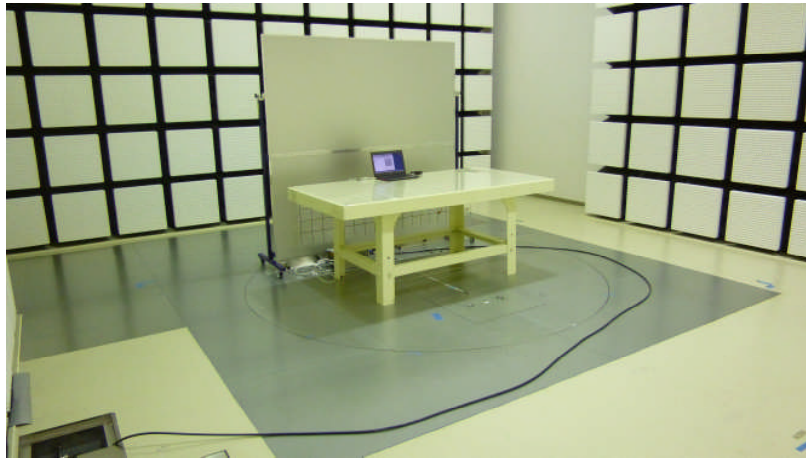

**Photo5 Test Setup for Conducted Test_1
(Front)**

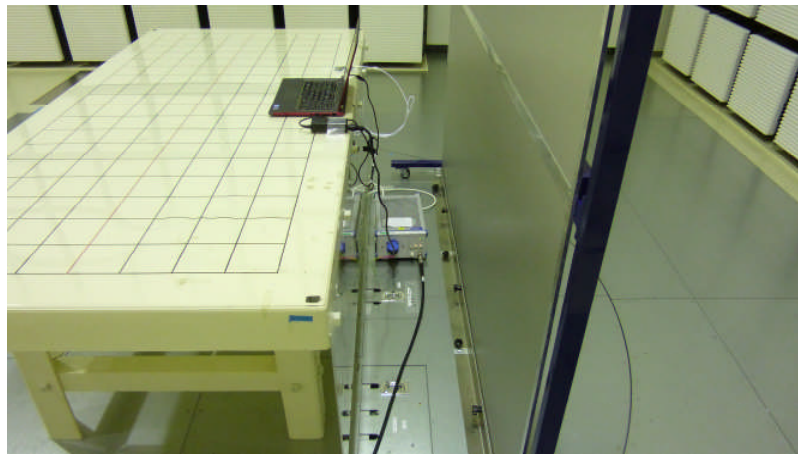

**Photo6 Test Setup for Conducted Test_2
(Back)**

5. Test facility

5.1 Test Instruments

5.1.1 Conducted Emissions

Product Name	Manufacturer	Model Number	Serial Number	Calibration Date	Due Date
Receiver	Rohde&Schwarz	ESCI	100485	2012/10/31	2013/10/31
LISN	Rohde&Schwarz	ENV216/02	100466	2013/10/03	2014/10/31

Table 14 Conducted Emissions

5.1.2 Radiated Spurious Emissions

Product Name	Manufacturer	Model Number	Serial Number	Calibration Date	Due Date
Receiver	Rohde&Schwarz	ESCI	100485	2012/10/31	2013/10/31
Pre-Amplifier	SONOMA	310N	270610	2013/7/11	2014/7/31
Roop Antenna	EMCO	6507	9108-1268	2013/4/3	2014/4/30
Biconical Antenna	Schwarzbeck	VHA9103B+BBA9106	91032542	2013/6/10	2014/6/30
Log-periodic Antenna	Schwarzbeck	UHALP918A	0779	2013/6/10	2014/6/30
Thermostatic chamber	Espec	LHU-113	1012003589	2013/3/11	2014/3/31

Table 15 Radiated Spurious Emissions

5.2 Test equipment

Dimension	Material	Measurement
0.69m(W) × 0.80m(H) × 0.43m(D)	Foamed Styrol	Radiated Spurious Emission
2.50m(W) × 1.00m(H) × 0.80m(D)	Wood	AC Conducted Emission

Table 16 Test equipment