



COMPANY NAME: NOKIA WIRELESS BUSINESS COMMUNICATIONS
EUT: NOKIA C110 AND C111
CLIENT REFERENCE NUMBER: QUOTE NUMBER
WORK ORDER NUMBER: 2000156
FCC ID: ORE-C110-C111

APPENDIX O:

ANTENNA TYPE SPECIFICATION



COMPANY NAME: NOKIA WIRELESS BUSINESS COMMUNICATIONS
EUT: NOKIA C110 AND C111
CLIENT REFERENCE NUMBER: QUOTE NUMBER
WORK ORDER NUMBER: 2000156
FCC ID: ORE-C110-C111

Omni

Dolphin

Omni Antenna Specification

Nokia C950

NWBC

17.12.1999

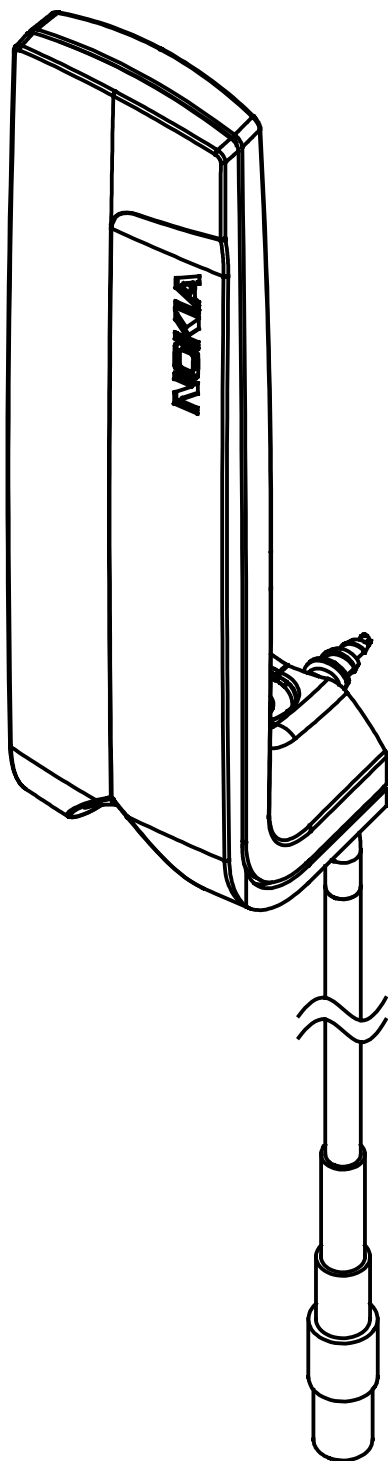

NWBC

17.12.1999

Table of contents:

1.	Introduction	4
2.	RF-Specification	4
3.	Mechanical Construction	5
4.	Antenna-element PCB.....	6
5.	Antenna Product Requirements.....	6
5.1	Type approval requirements.....	6
5.2	Product safety requirements	6
5.3	EMC requirements	6
5.4	Environmental requirements	7
5.5	Mechanical requirements	7
6.	Cable Specification.....	8
7.	Cable connector	9

NWBC

17.12.1999

1. INTRODUCTION

This document describes the main specifications for an external antenna unit of Nokia C111 WLAN PC-card.

2. RF-SPECIFICATION

Antenna type	omni
Frequency range	2400 –2485 MHz
Return loss	> 15 dB with cable
Gain	0 dB _d without cable
Impedance	50 Ω
Polarization	Vertical
H-angle (3 dB)	360 °
Max total power input	5 W

NWBC

17.12.1999

3. MECHANICAL CONSTRUCTION

Mechanical construction is described in Figure 1.

Antenna cover material: Cycoloy C2800, color 26064

Outer surface: Quality 1 Moss 800/6, Mould electroeroded VDI 3400 Nr.30 (Ra 3.2)

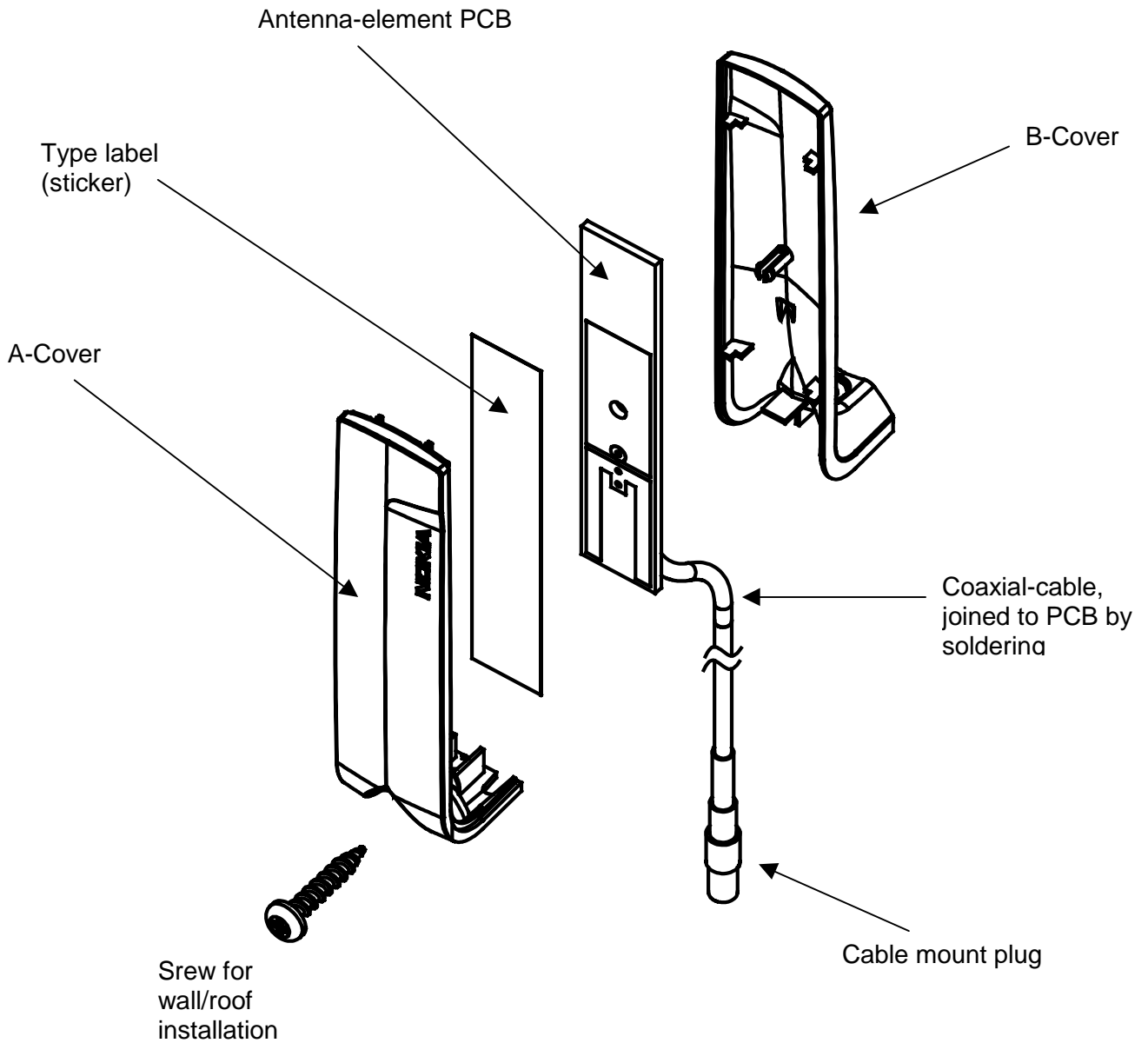

Figure 1

NWBC

17.12.1999

4. ANTENNA-ELEMENT PCB

Main specification: NMP DHS00001-EN
 Dielectric values for core and prepreg materials (FR4)
 Dielectric constant, $\epsilon_r = 4.5 \pm 0.2$ at 1MHz
 $= (4.0 \pm 0.2)$ from 1 to 2 GHz
 Dissipation factor < 0.03 at 1 MHz
 Use of single-ply prepared allowed
 Any changes to this build up or base materials must be agreed with NWBC.
Allgon will specify the PCB which will be used.

5. ANTENNA PRODUCT REQUIREMENTS

5.1 Type approval requirements

- Antenna connector has to be unique (CFR part 15, national regulations).
- Antenna has to have CE mark and some national approval marks (Norway, Switzerland) in Europe. In US no marking requirements for the antenna.
- The marking has to be visible in a visible location and permanently affixed.
- Different antenna types have to be able to be identified from each other (which antenna can be used where and with what card), type designation.

5.2 Product safety requirements

- Antenna must be constructed so, that in normal use and fault conditions it protects the user against risk of personal injury, e.g. electric shock
- No sharp edges or corners or other mechanical hazards which can harm the user
- Minimize the risk of ignition and spread of flame, materials have to have flammability classes of V-0 or V-1.
- Under normal use, equipment or its components shall not attain excessive temperatures

5.3 EMC requirements

Tests are done for the card with antenna connected to it:

Immunity

Requirement	Performance value	Reference
Electrostatic discharge	4 kV contact / 8 kV air	EN 61000-4-2
RF field 80 to 1000MHz	>3 V/m RF-field strength	EN 61000-4-3
Common mode RF disturbance	3 V rms inductive coupling to antenna cable	EN 61000-4-6

-ESD pulses are applied to all surfaces (connector, insulation and housing).

NWBC

17.12.1999

Emission

Requirement	Performance value	Reference
Total system emission limits	According to the standards	ETS 300 328, EN 300 826
E.I.R.P	-10dBW (100mW)	ETS 300 328
Gain	≤ 6dBi, otherwise peak output power must be reduced by 1 dB for every 3 dB exceeding the limit.	CFR Part 15.247

5.4 Environmental requirements

Requirement	Performance value	Reference
Cold Storage	-40°C, 16h	IEC 60068-2-1Ab
Cold operational	-5°C, 16h	IEC 60068-2-1Ab
Dry heat operational	+55/+70, 16h+2h	IEC 60068-2-2Bb
Dry heat Storage	+85°C, 16h	EC 60068-2-2Bb
Change of temperature	-40 ... +85°C, Change time <3 minutes, 5 cycles	IEC 60068-2-14Na
Damp heat cycle	+25/+55°C, 90 ... 100% Rh, 6 cycles (12h+12h)	IEC 60068-2-30Db
Solar radiation	+55 / +25°C, 1120 W/m², 10 cycles	IEC 60068-2-5Sa An

5.5 Mechanical requirements

Requirement	Performance value	Reference
Sinusoidal Vibration	8-200 Hz 19.6 m/s² 3 x 90 minutes	IEC 60068-2-6Fc
Random Vibration	10 –100 Hz 3m²/s³ 3 x 60 minutes	IEC 60068-2-36Fdb
Bumb	245 m/s² 6ms 3000 bumbs	IEC 60068-2-29Eb
Free fall	3 cycles 3 times 2 falls Height of fall 1.5 m	IEC 60068-2-32Ed

NWBC

17.12.1999

6. CABLE SPECIFICATION

If the cable is not approved by Nokia, certain tests has to be carried out according to the separate specification for cable testing.

Dimensions	Maximum outer diameter of the cable: 2.8 mm This is because of the cable mount plug.
	Length of the cable: 2.0m
Electrical values	Operating frequency: Up to 3 GHz Attenuation: Max. 1.5dB/m at the 2.4GHz frequency.
Mechanical values	Minimum static bend radius: <15mm Minimum dynamic bend radius: <50mm
Color	Matt grey
Stripping and mating	The end of the cable which will be connected to the antenna-element PCB must be stripped by the instructions given by Allgon.
Cable mount plug	For the end of cable with cable mount plug, a heat shrinkable tube must be added. The Color of the heat shrinkable tube must be same as the color of the cable.

Cable is described in figure 2, detailed drawing TBD.

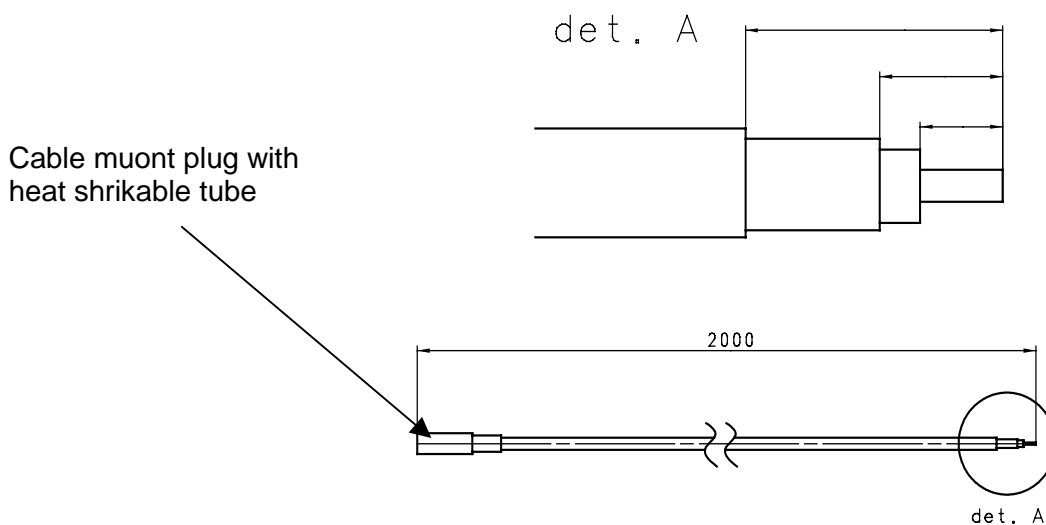

Figure 2

NWBC

17.12.1999

7. CABLE CONNECTOR**Connector type:** Cable mount plug IMS.

In figure 3. Is described the heat shrinkable tube for the cable mount plug.

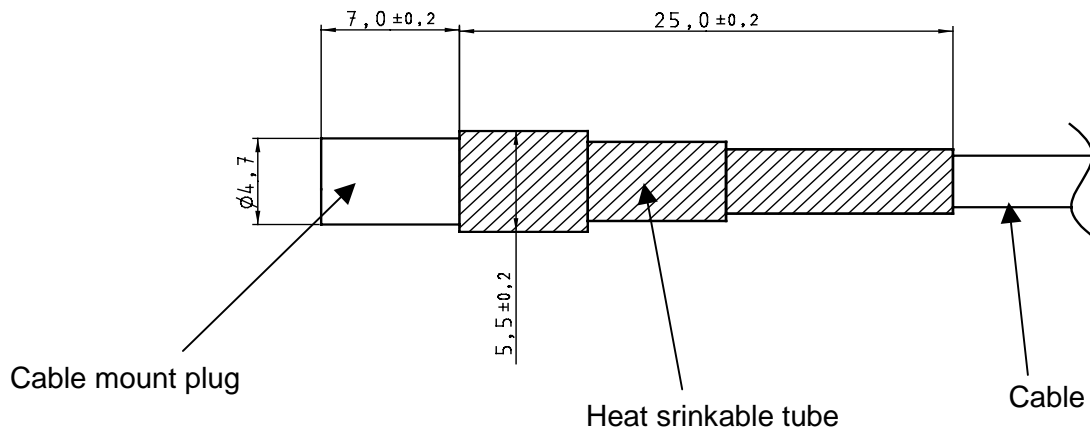
**Figure 3.**



COMPANY NAME: NOKIA WIRELESS BUSINESS COMMUNICATIONS
EUT: NOKIA C110 AND C111
CLIENT REFERENCE NUMBER: QUOTE NUMBER
WORK ORDER NUMBER: 2000156
FCC ID: ORE-C110-C111

Omni integral

Internal antenna specification is:

Antenna type	Capacitive loaded symmetric dual loop
Frequency range	2400 -2483,5 MHz
Bandwidth	83,5 MHz
Gain	+ 1 dBi (peak gain)
VSWR	< 2.5 over frequency range
Radiation Pattern	omni directional (see measurement plots)
Polarisation	Linear, H&V
Impedance	50 W
Operating temperature	0 - +70
Compliance with Part 15.247(b)(3)	Yes, gain < 6 dBi
Calculated EIRP (dBm)	16 dBm (peak power)
Max total power input	4 W



COMPANY NAME: NOKIA WIRELESS BUSINESS COMMUNICATIONS
EUT: NOKIA C110 AND C111
CLIENT REFERENCE NUMBER: QUOTE NUMBER
WORK ORDER NUMBER: 2000156
FCC ID: ORE-C110-C111

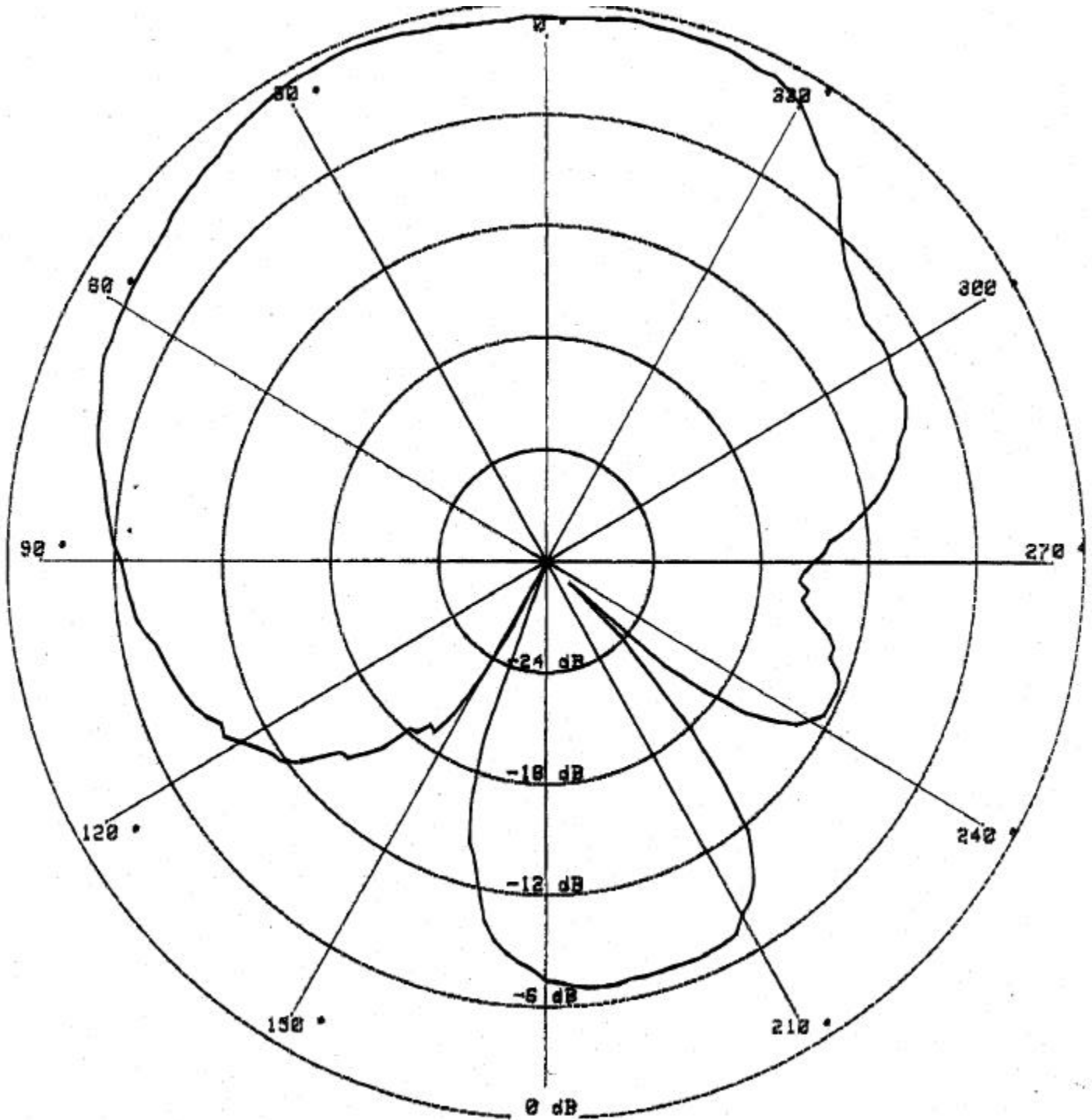



COMPANY NAME: NOKIA WIRELESS BUSINESS COMMUNICATIONS
EUT: NOKIA C110 AND C111
CLIENT REFERENCE NUMBER: QUOTE NUMBER
WORK ORDER NUMBER: 2000156
FCC ID: ORE-C110-C111

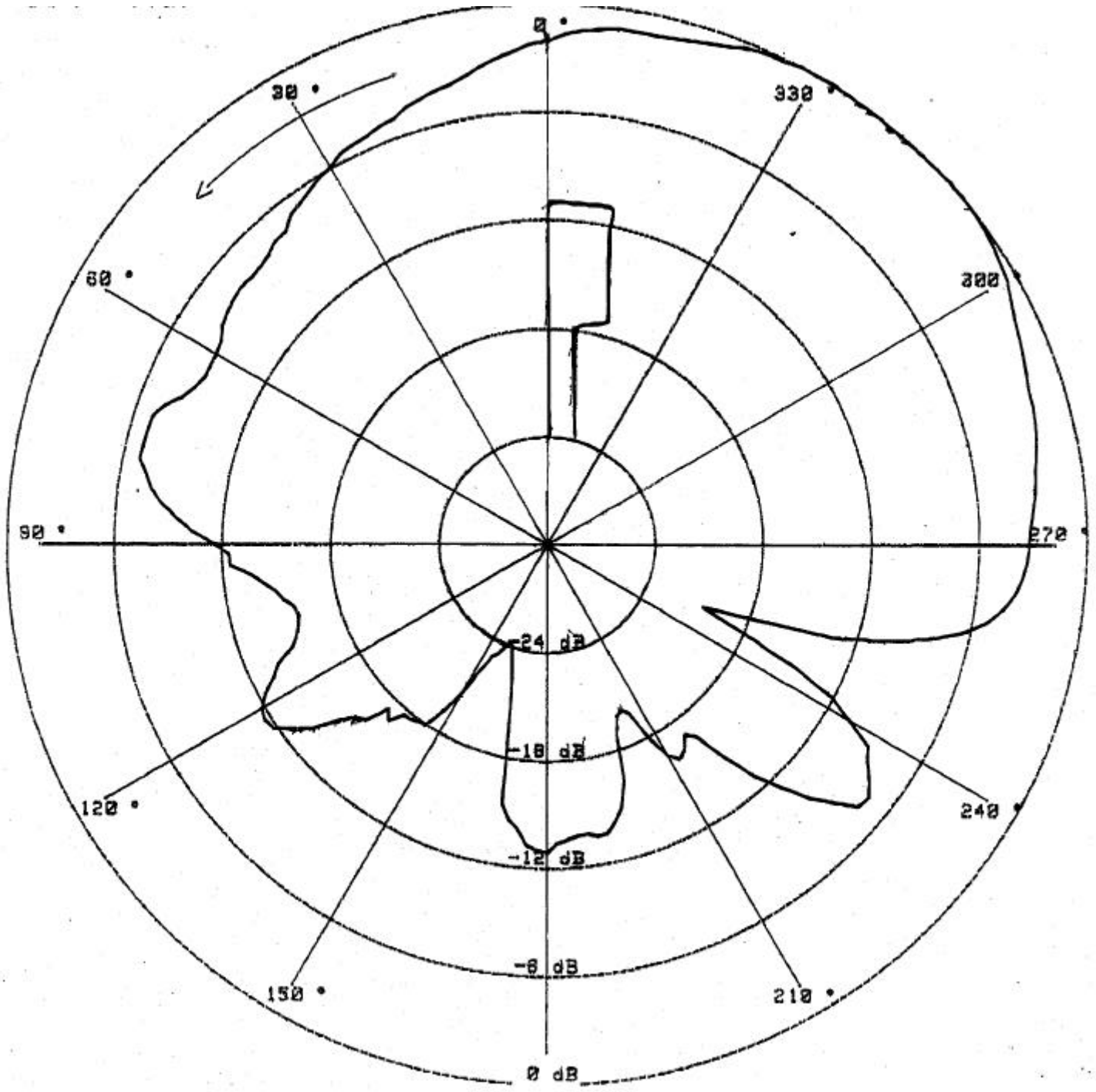



COMPANY NAME: NOKIA WIRELESS BUSINESS COMMUNICATIONS
EUT: NOKIA C110 AND C111
CLIENT REFERENCE NUMBER: QUOTE NUMBER
WORK ORDER NUMBER: 2000156
FCC ID: ORE-C110-C111

Dipole

The following specification includes the Yagi Antenna which is not a part of this application as an antenna option. The antennas included in this application are the external antenna: Dipole and Omni and Internal antenna: Omni Integral.

Dolphin

Yagi Antenna Specification

Nokia C960

Nokia C961

Nokia C962

NWBC

21.12.1999

Table of contents:

1	Introduction	3
2	RF-specification.....	4
2.1	Bidirectional dual dipole Nokia C960.....	4
2.2	Directional Yagi (Europe) Nokia C961.....	4
2.3	Directional Yagi (US) Nokia C962	4
3	Mechanical Construction	5
4	antenna element pcb specification.....	6
5	Antenna Product Requirements.....	6
5.1	Type approval requirements.....	6
5.2	Product safety requirements	6
5.3	EMC requirements	6
5.4	Environmental requirements	7
5.5	Mechanical requirements	7
6	Cable Specification.....	8
7	Cable connector	9

NWBC

21.12.1999

1 INTRODUCTION

This document describes three different type of directional antennas to same mechanical construction see figure 1.

Antenna types are:

- Bidirectional dual dipole
- Directional Yagi (Europe)
- Directional Yagi (US)

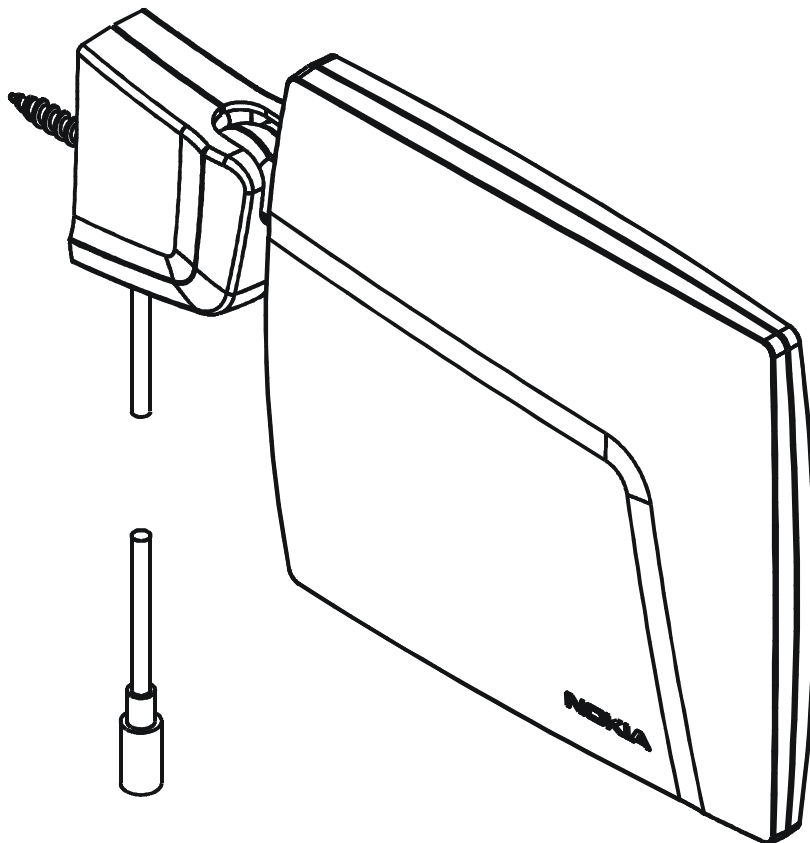

Figure 1.

NWBC

21.12.1999

2 RF-SPECIFICATION

2.1 Bidirectional dual dipole Nokia C960

Frequency range	2400 –2485 MHz
Return loss (with cable)	> 15 dB
Gain	< 4 dB _i without cable
Impedance	50 Ω
Polarization	Horizontal/Vertical (depending on fixing position)
H-angle (3 dB)	-
Max total power input	5 W

2.2 Directional Yagi (Europe) Nokia C961

Frequency range	2400 –2485 MHz
Return loss (with cable)	> 15 dB
Gain	< 7 dB _i without cable
Impedance	50 Ω
Polarization	Horizontal/Vertical (depending on fixing position)
H-angle (3 dB)	-
Max total power input	5 W

2.3 Directional Yagi (US) Nokia C962

Frequency range	2400 –2485 MHz
Return loss (with cable)	> 15 dB
Gain	< 9 dB _i without cable
Impedance	50 Ω
Polarization	Horizontal/Vertical (depending on fixing position)
H-angle (3 dB)	-
Max total power input	5 W

NWBC

21.12.1999

3 MECHANICAL CONSTRUCTION

Mechanical construction is showed in figure 2.

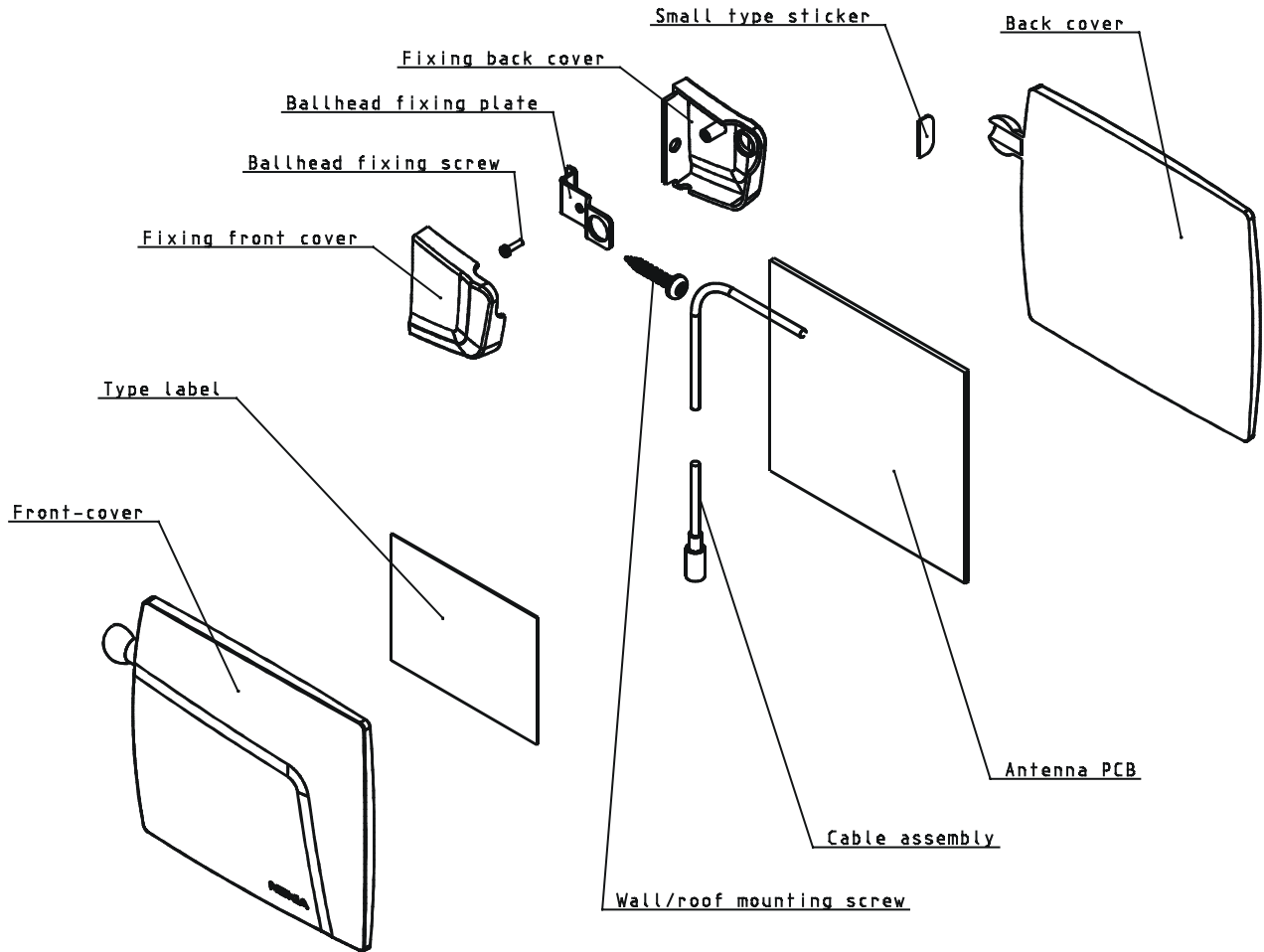

Figure 2.

Outer surface: Quality 1 Moss 800/6, Mould electroeroded VDI 3400 Nr.30 (Ra 3.2)

Part list:

no:	Name	Material
1	Back cover	Cycoloy C2800, Color WH7178
2	Antenna PCB with cable	
3	Type label	
4	Small type sticker	
5	Front cover	Cycoloy C2800, Color WH7178
6	Fixing back cover	Cycoloy C2800, Color 26064
7	Ballhead fixing plate	Stainless steel
8	Gallhead fixing screw	PT Screw
9	Fixing front cover	Cycoloy C2800, Color 26064
10	Wall/roof mounting screw	

NWBC

21.12.1999

4 ANTENNA ELEMENT PCB SPECIFICATION

Main specification: NMP DHS00001-EN

Dielectric values for core and prepreg materials (FR4)

Dielectric constant, $\epsilon_r = 4.5 \pm 0.2$ at 1MHz
 $= (4.0 \pm 0.2)$ from 1 to 2 GHz)

Dissipation factor <0.03 at 1 MHz

Use of single-ply prepared allowed

Any changes to this build up or base materials must be agreed with NWBC.

5 ANTENNA PRODUCT REQUIREMENTS

5.1 Type approval requirements

- Antenna connector has to be unique (CFR part 15, national regulations).
- Antenna has to have CE mark and some national approval marks (Norway, Switzerland) in Europe. In US no marking requirements for the antenna.
- The marking has to be visible in a visible location and permanently affixed.
- Different antenna types have to be able to be identified from each other (which antenna can be used where and with what card), type designation.

5.2 Product safety requirements

- Antenna must be constructed so, that in normal use and fault conditions it protects the user against risk of personal injury, e.g. electric shock
- No sharp edges or corners or other mechanical hazards which can harm the user
- Minimize the risk of ignition and spread of flame, materials have to have flammability classes of V-0 or V-1.
- Under normal use, equipment or its components shall not attain excessive temperatures

5.3 EMC requirements

Tests are done for the card with antenna connected to it:

Immunity

Requirement	Performance value	Reference
Electrostatic discharge	4 kV contact / 8 kV air	EN 61000-4-2
RF field 80 to 1000MHz	>3 V/m RF-field strength	EN 61000-4-3
Common mode RF disturbance	3 V rms inductive coupling to antenna cable	EN 61000-4-6

-ESD pulses are applied to all surfaces (connector, insulation and housing).

Emission

Requirement	Performance value	Reference
Total system emission limits	according to the standards	ETS 300 328, EN 300 826
E.I.R.P	-10dBW (100mW)	ETS 300 328
Gain	≤ 6dBi, otherwise peak output power must be reduced by 1 dB for every 3 dB exceeding the limit.	CFR Part 15.247

NWBC

21.12.1999

Other requirements

Requirement	Value	Remarks
Cable length	< 3 m	If longer, more tests have to be done which are difficult to pass.

5.4 Environmental requirements

Requirement	Performance value	Reference
Cold Storage	-40°C, 16h	IEC 60068-2-1Ab
Cold operational	-5°C, 16h	IEC 60068-2-1Ab
Dry heat operational	+55/+70, 16h+2h	IEC 60068-2-2Bb
Dry heat Storage	+85°C, 16h	EC 60068-2-2Bb
Change of temperature	-40 ... +85°C, Change time <3 minutes, 5 cycles	IEC 60068-2-14Na
Damp heat cycle	+25/+55°C, 90 ... 100% Rh, 6 cycles (12h+12h)	IEC 60068-2-30Db
Solar radiation	+55 / +25°C, 1120 W/m ² , 10 cycles	IEC 60068-2-5Sa An

5.5 Mechanical requirements

Requirement	Performance value	Reference
Sinusoidal Vibration	TBD	TBD
Random Vibration	TBD	TBD
Bumb	TBD	TBD
Free fall	3 cycles 3 times 2 falls Height of fall 1.5 m	IEC 60068-2-32Ed

NWBC

21.12.1999

6 CABLE SPECIFICATION

If the cable is not approved by Nokia, certain tests has to be carried out according to the separate specification for cable testing.

Dimensions	Maximum outer diameter of the cable: 2.8 mm This is because of the cable mount plug. Length of the cable: 2.0m
Electrical values	Operating frequency: Up to 3 GHz Attenuation: Max. 1.5dB/m at the 2.4GHz frequency.
Mechanical values	Minimum static bend radius: <15mm Minimum dynamic bend radius: <50mm
Color	Matt grey
Stripping and mating	The end of the cable which will be connected to the antenna-element PCB must be stripped by the instructions given by Allgon.
Cable mount plug	For the end of cable with cable mount plug, a heat shrinkable tube must be added. The Color of the heat shrinkable tube must be same as the color of the cable.

Cable is described in figure 3, detailed drawing TBD.

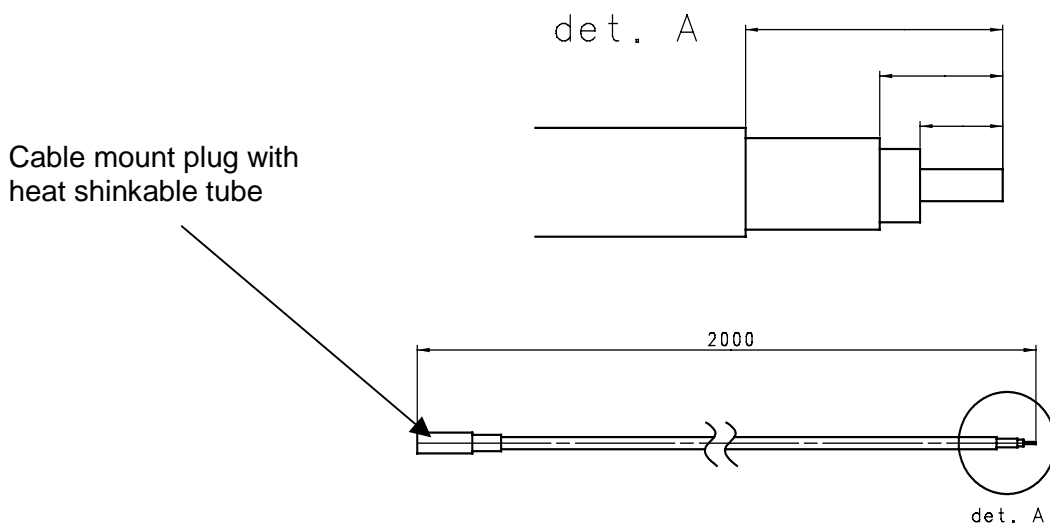

Figure 3

NWBC

21.12.1999

7 CABLE CONNECTOR**Connector type:** Cable mount plug IMS.

In figure 4. Is described the heat shrinkable tube for the cable mount plug.

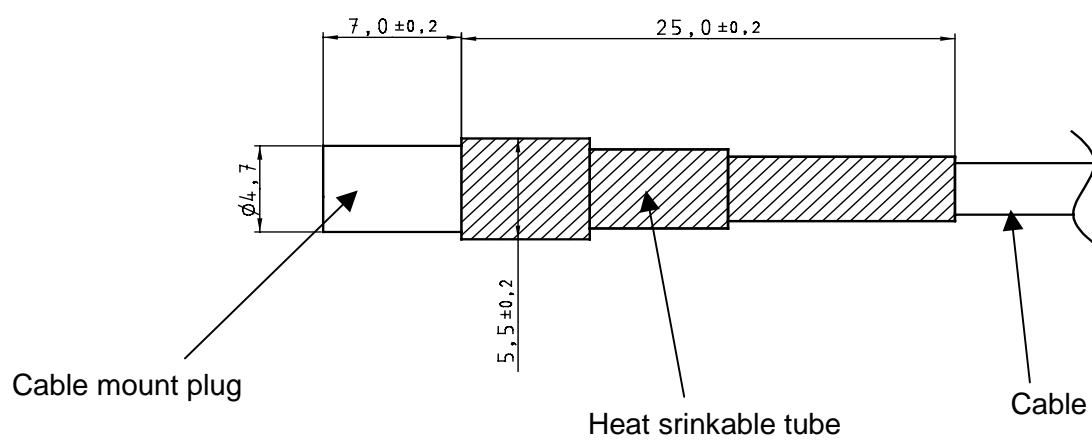
**Figure 4.**