

# TRANSMITTER MTXUS03A

## TECHNICAL CHARACTERISTICS

NORMATIVE REFERENCE .....	FCC part 90
TYPE OF EQUIPMENT .....	TRANSMITTER WITH INTEGRAL OR DEDICATED ANTENNA (simplex)
FREQUENCY CHARACTERISTICS .....	SYNTHESIZER (REF. 12.8 MHz)
ALIGNMENT RANGE (AR1) .....	UHF 450-470 MHz
SWITCHING RANGE .....	ANY 3.2 MHz SUB BAND
CHANNEL SEPARATION* .....	12.5 kHz
MAXIMUM NUMBER OF CHANNELS .....	256
POWER LEVEL RADIATED (class IA) .....	≤ 20 mW ERP
TYPE OF MODULATION (digital)* .....	GFSK (FFSK optional)
MODULATION BIT RATE* .....	standard 4.800bit/s (up to 19.200 bit/s optional)
MAXIMUM FREQUENCY DEVIATION* .....	+/- 2.5 kHz
EXTREME TEMPERATURE RANGE (category 1) .....	-20° C ÷ +55° C
NOMINAL SOURCE VOLTAGE .....	6 V
EXTREME SOURCE VOLTAGES .....	5.6 ÷ 15 V
DC MAXIMUM CURRENT .....	≤ 60 mA
FREQUENCY ERROR .....	+/- 1 kHz
ADIACENT CHANNEL POWER* (class IA) .....	≤ 200 nW
POWER SPURIOUS EMISSIONS (conducted or radiated)	
FREQUENCY RANGE 47÷74MHz, 87,5÷118MHz, 174÷230MHz, 470÷862MHz .....	< 4 nW
FREQUENCY RANGE < 1GHz .....	< 250 nW
FREQUENCY RANGE > 1GHz .....	< 1 µW
DIMENSIONS .....	101 x 60 x 7 mm

\* THESE VALUES ARE MEASURED AT STANDARD BIT RATE (4800 bit/s), WHEN EMPLOYING GFSK MODULATION AND WIDE BAND CHANNEL SPACING, IT IS POSSIBLE TO OPERATE THE RADIO MODULE AT BIT RATES UP TO 19200 bits/s

# Functional description of MTXUS03A

## radio transmitter module

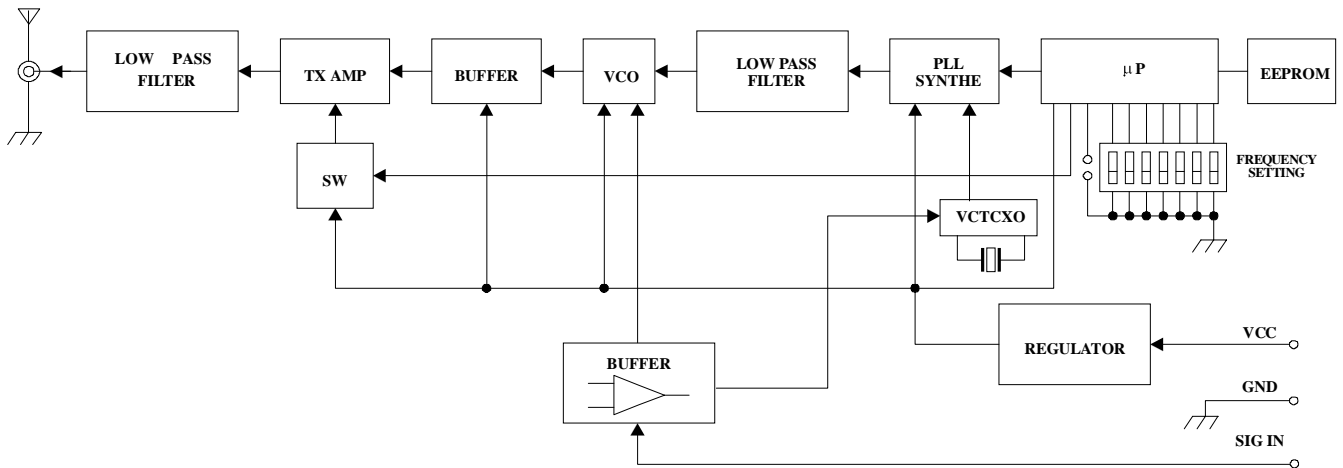

The module is a PLL synthesized digital data transmitter, operating in the 450-470 ISM band as a lower power device (20 mW ERP). Two-point PLL frequency modulation, with an input bandwidth from 0.5 to 10000 Hz, allows for the implementation of any frequency-shift keying (F1D) or subcarrier FM (F2D) modulation scheme; for example, if a gaussian-filtered 4800 bps data stream of 1Vpp is applied to the modulation input, a narrow band Gaussian FSK ( $\Delta f = \pm 2400$  Hz) is obtained which is compatible with 12.5 kHz channel spacing. Alternatively, a 1 Vpp subcarrier at 1800 Hz, MSK modulated at 2400 Baud, could be used on the same 12.5 kHz channel.

The carrier frequency is generated by a Voltage Controlled Oscillator (VCO, Q4, Q5), which is phase locked to a 12.8 MHz  $\pm 2.5$ ppm reference frequency Voltage Controlled Temperature Compensated Xtal Oscillator (VCTCXO, U3). The PLL frequency synthesizer (U1) is programmed by a microcontroller (U5), which reads default data from an EEPROM (U2) and user data from a dip-switch; a low-pass filter, driving the control input of the VCO (DV1, DV2), closes the PLL feedback loop. The signal coming from the VCO is amplified by Q6 and Q7; the correct 20mW output power level can be adjusted by P1. Before reaching the antenna, the RF passes through a fifth order low-pass filter (L8, L9, C52, C56, C57), in order to prevent the harmonics to be radiated.

The modulating signal is buffered and splitted into two paths (U2, P2, P3), in order to obtain a balanced effect from the in-loop (DV3 on VCO) and out-of-loop (VCTCXO freq. adj. Input) modulation points. This modulation technique overrides the high-pass effect encountered when only the VCO is modulated, giving a FM characteristic which is linear down to d.c. and allows for clean digital frequency keying.

The power supply is regulated to 5V by U6, a low-drop out device. The microprocessor inhibits the 5V line of the RF power amplifier when the PLL is out of lock, in order to avoid radiating high-level RF signals outside the permitted band. A PTT line can reduce the output power to by 30-40 dB, when needed. A SETUP signal can shift the output frequency by +50 kHz, with respect to the nominal value set on the dip switches; this feature is used to ease frequency setting when operating a three point system (ex. fixed data transmitter on F+50kHz, fixed remote control receiver on F, handheld remote control unit transmitting commands at F and receiving data at F+50kHz).