

Gandini 21097230

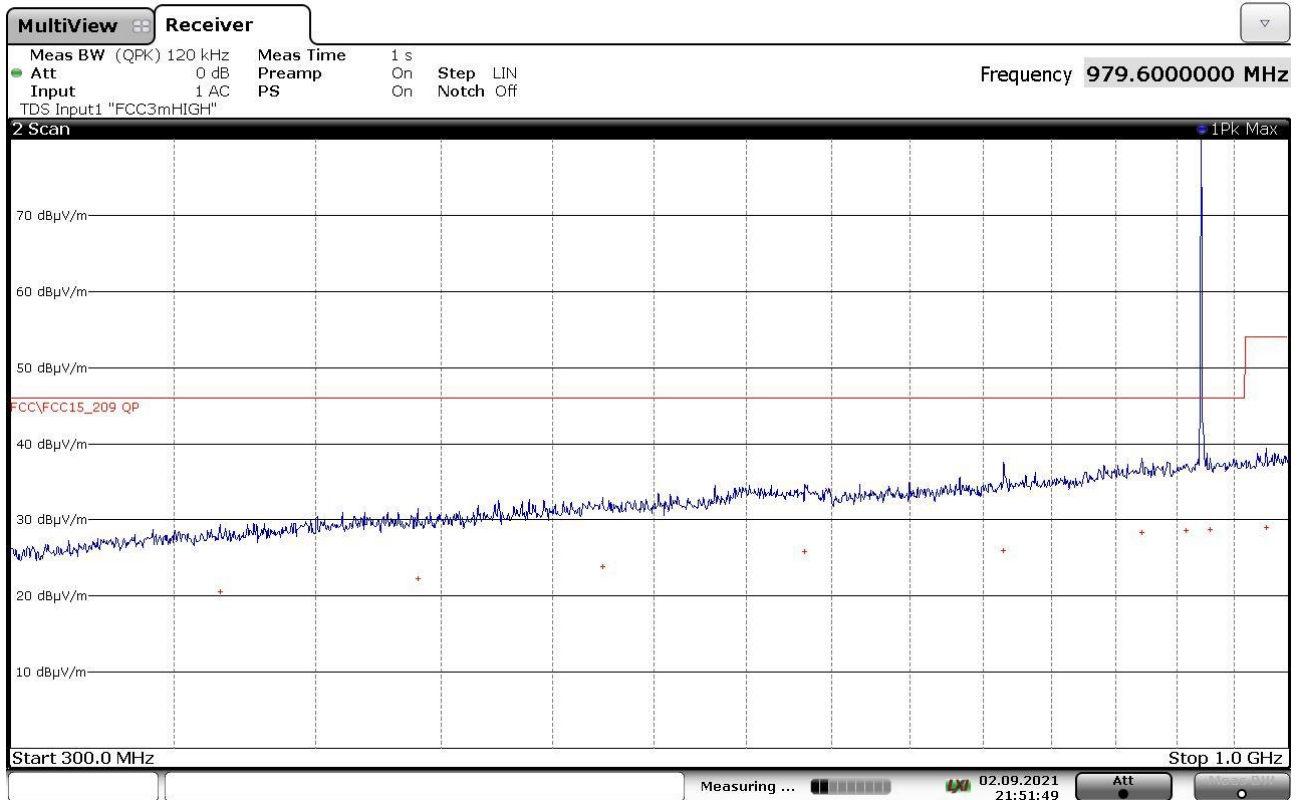

FINAL RESULT TABLE

QUASI PEAK		
Freq Hz	Lev dBuV/m	Margin dB
365480000	+20,53	-25,49
440360000	+22,32	-23,70
524240000	+23,83	-22,19
634160000	+25,85	-20,17
764760000	+26,01	-20,01
871160000	+28,34	-17,68
908440000	+28,62	-17,40
928760000	+28,71	-17,31
979600000	+28,96	-25,02

21097230_2

Gandini 21097231

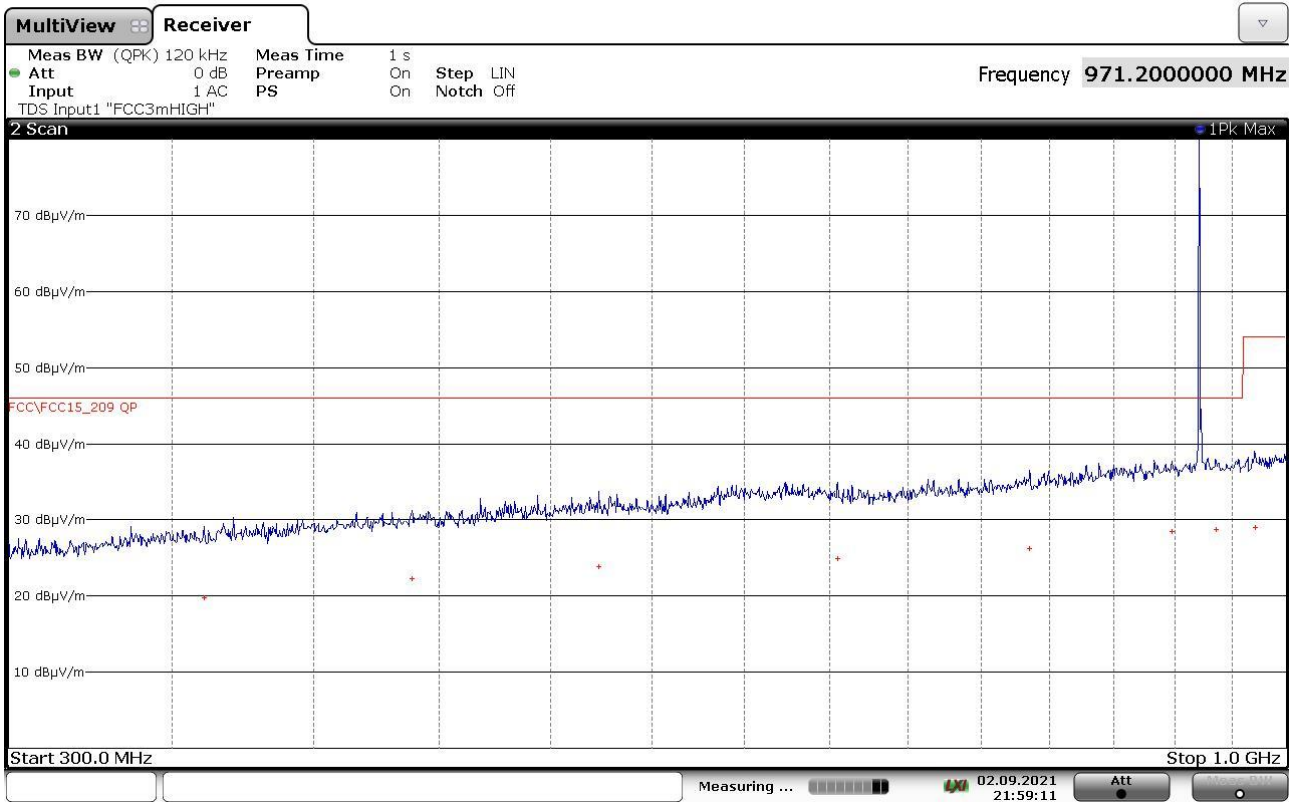

FINAL RESULT TABLE

QUASI PEAK		
Freq Hz	Lev dBuV/m	Margin dB
360680000	+19,79	-26,23
438840000	+22,27	-23,75
523200000	+23,84	-22,18
654960000	+24,86	-21,16
785200000	+26,19	-19,83
897680000	+28,49	-17,53
935520000	+28,73	-17,29
971200000	+28,96	-25,02

21097231_2

Gandini 21097232

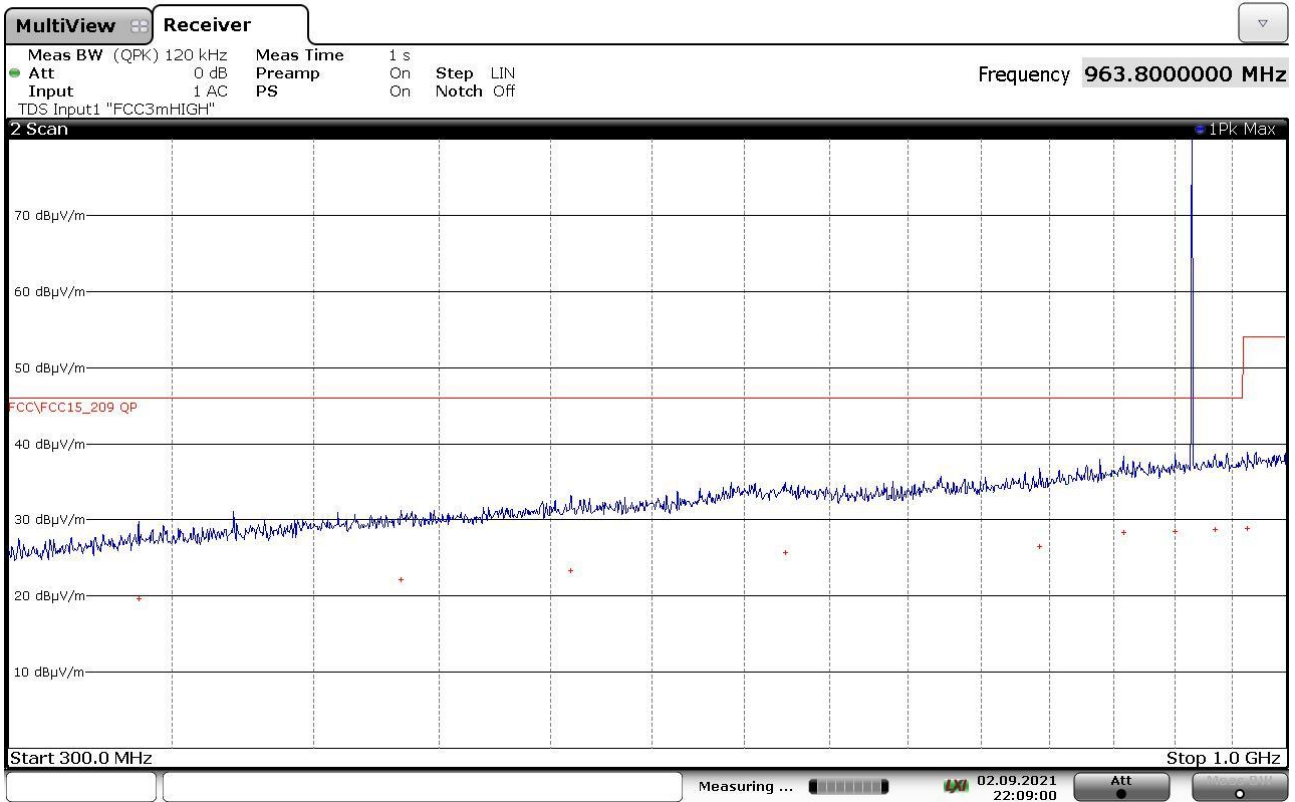

FINAL RESULT TABLE

QUASI PEAK		
Freq Hz	Lev dBuV/m	Margin dB
339120000	+19,63	-26,39
434160000	+22,14	-23,88
509720000	+23,36	-22,66
623640000	+25,76	-20,26
792600000	+26,48	-19,54
857880000	+28,29	-17,73
900440000	+28,42	-17,60
934920000	+28,75	-17,27
963800000	+28,88	-25,10

21097232_2

Gandini 21097233

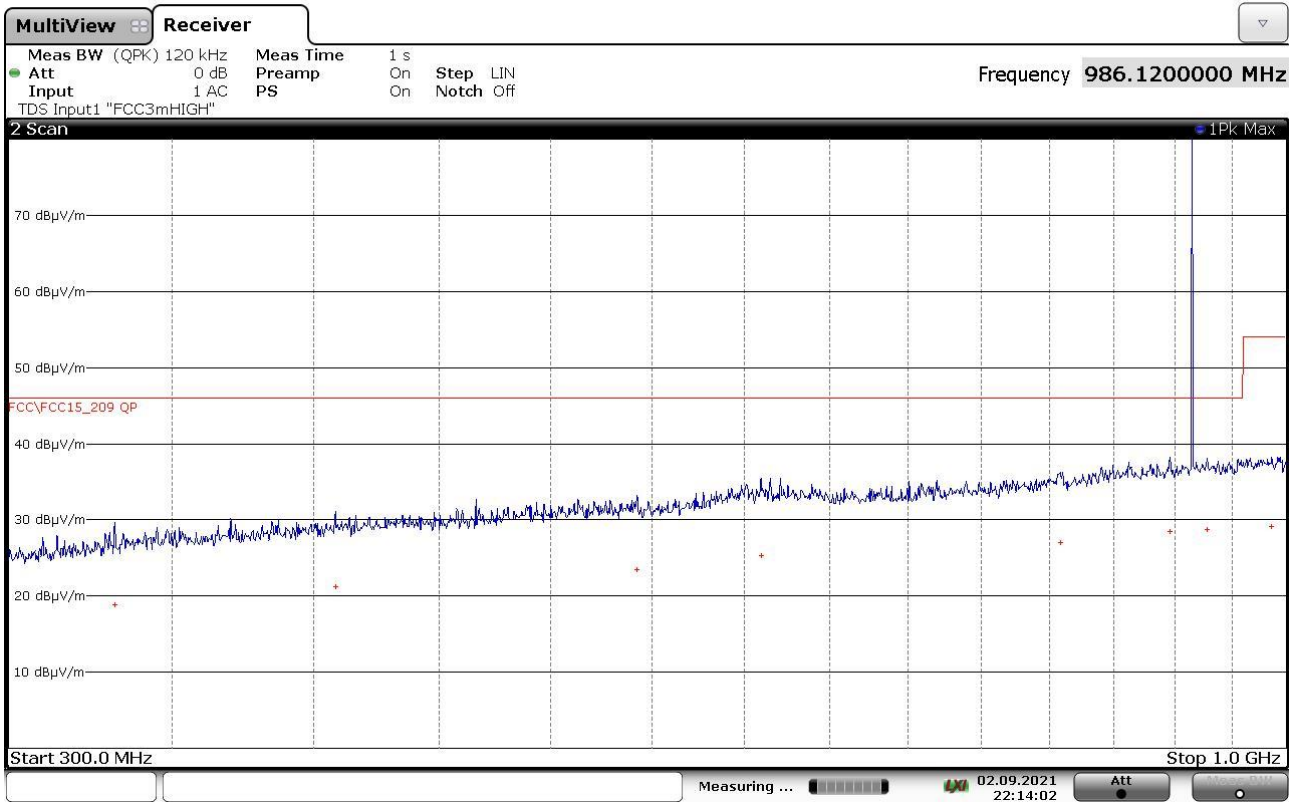

FINAL RESULT TABLE

QUASI PEAK		
Freq Hz	Lev dBuV/m	Margin dB
331520000	+18,90	-27,12
408200000	+21,22	-24,80
542520000	+23,51	-22,51
609520000	+25,33	-20,69
808000000	+27,06	-18,96
895920000	+28,46	-17,56
928000000	+28,72	-17,30
986120000	+29,15	-24,83

21097233_2

9.4 20 dB bandwidth

Tested by	G. Gandini
Test date	06.09.2021
Test location (stand)	Laboratory
Reference standards	FCC Rules and Regulation; Titles 47 Part. 15.247 ANSI C63.10 cl. 7.8.7
Supplementary test set-up description	--
Supplementary information.....	--

Acceptance limits

The maximum allowed 20 dB bandwidth of the hopping channel is 500 kHz

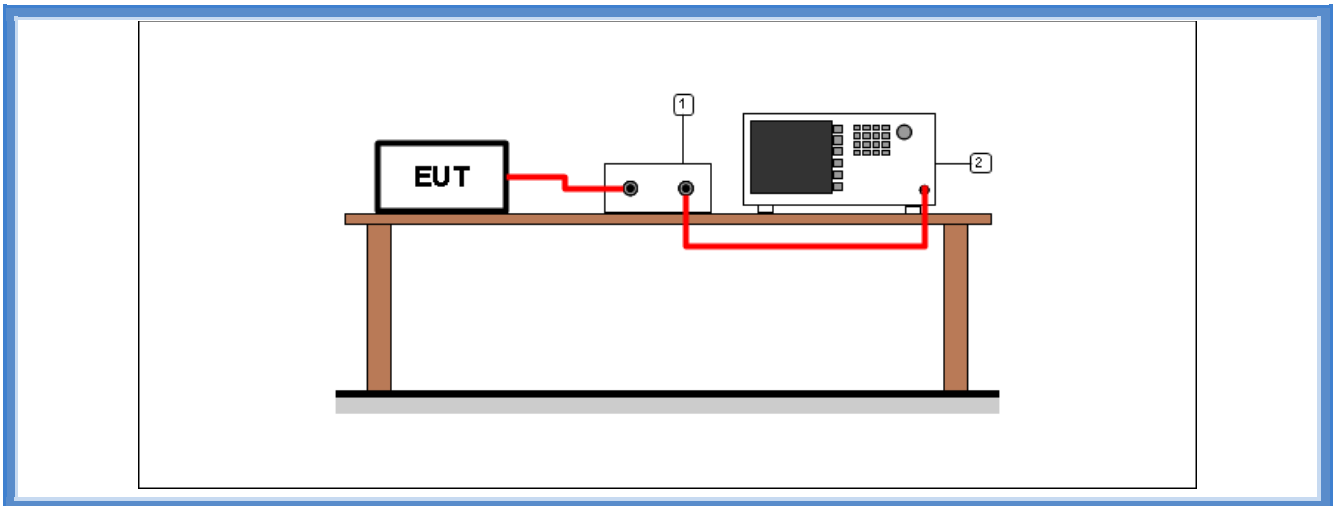

Test setup PR002_01

Nr.	Id. Number	Manufacturer	Model	Description
2	CMC S295	Rohde & Schwarz	FSW43	Spectrum Analyzer 43GHz
1	--	--	--	Cable + attenuator (calibrated before the test)

Result

Frequency (MHz)	Graphs	20 dB bandwidth (kHz)	Maximum 20 dB bandwidth allowed (kHz)	Results
915,050	G21097234	15,485	500	Complies
921,400	G21097245	15,634	500	Complies
927,800	G21097242	16,034	500	Complies

Graphs

Gandini 21097234



Gandini 21097242



Gandini 21097245



9.5 Channel separation

Tested by	G. Gandini
Test date	06.09.2021
Test location (stand)	Laboratory
Reference standards	FCC Rules and Regulation; Titles 47 Part. 15.247 KDB 558074 D01 15.247 Meas Guidance v05r02 cl. 9 b) ANSI C63.10 cl. 7.8.2
Supplementary test set-up description	--
Supplementary information.....	--

Acceptance limits

Frequency hopping systems shall have hopping channel carrier frequencies separated by a minimum of 25 kHz or the 20 dB bandwidth of the hopping channel, whichever is greater. Alternatively, frequency hopping systems operating in the 2400–2483.5 MHz band may have hopping channel carrier frequencies that are separated by 25 kHz or two-thirds of the 20 dB bandwidth of the hopping channel, whichever is greater, provided the systems operate with an output power no greater than 125 mW. The system shall hop to channel frequencies that are selected at the system hopping rate from a pseudo randomly ordered list of hopping frequencies. Each frequency must be used equally on the average by each transmitter. The system receivers shall have input bandwidths that match the hopping channel bandwidths of their corresponding transmitters and shall shift frequencies in synchronization with the transmitted signals

Test setup

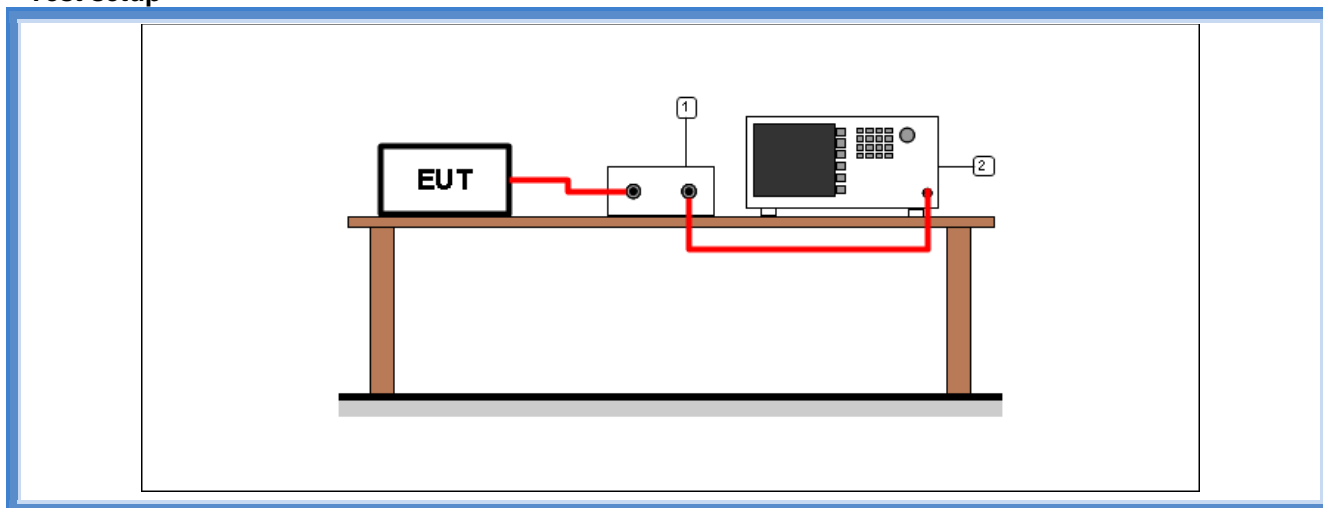

Test setup PR002_01

Nr.	Id. Number	Manufacturer	Model	Description
2	CMC S295	Rohde & Schwarz	FSW43	Spectrum Analyzer 43GHz
1	--	--	--	Cable + attenuator (calibrated before the test)

Result

<i>Frequency band (MHz)</i>	<i>Graphs</i>	<i>Channel separation (kHz)</i>	<i>Minimum channel separation required (kHz)</i>	<i>Results</i>
902 – 928	G21097247 G21097247	99,8	25	Complies

Graphs

Gandini 21097247

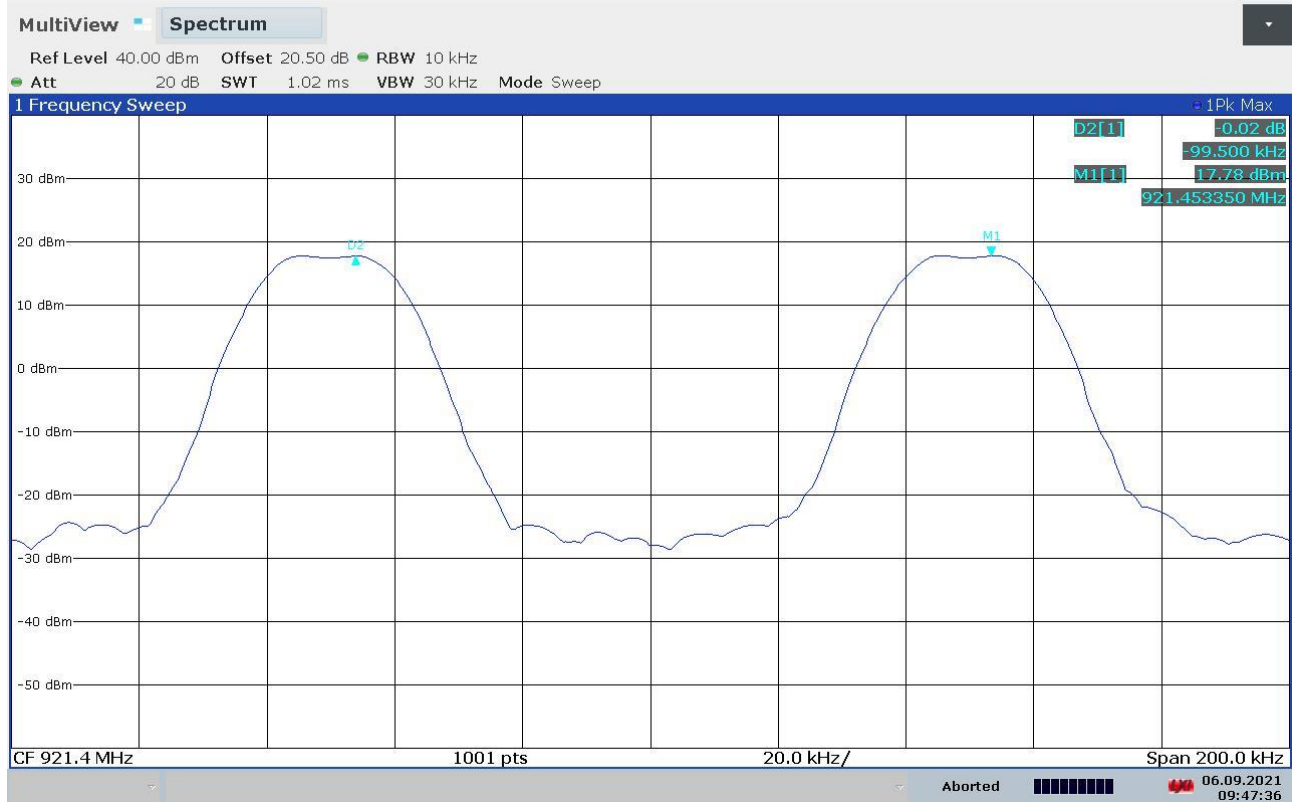

Gandini 21097248

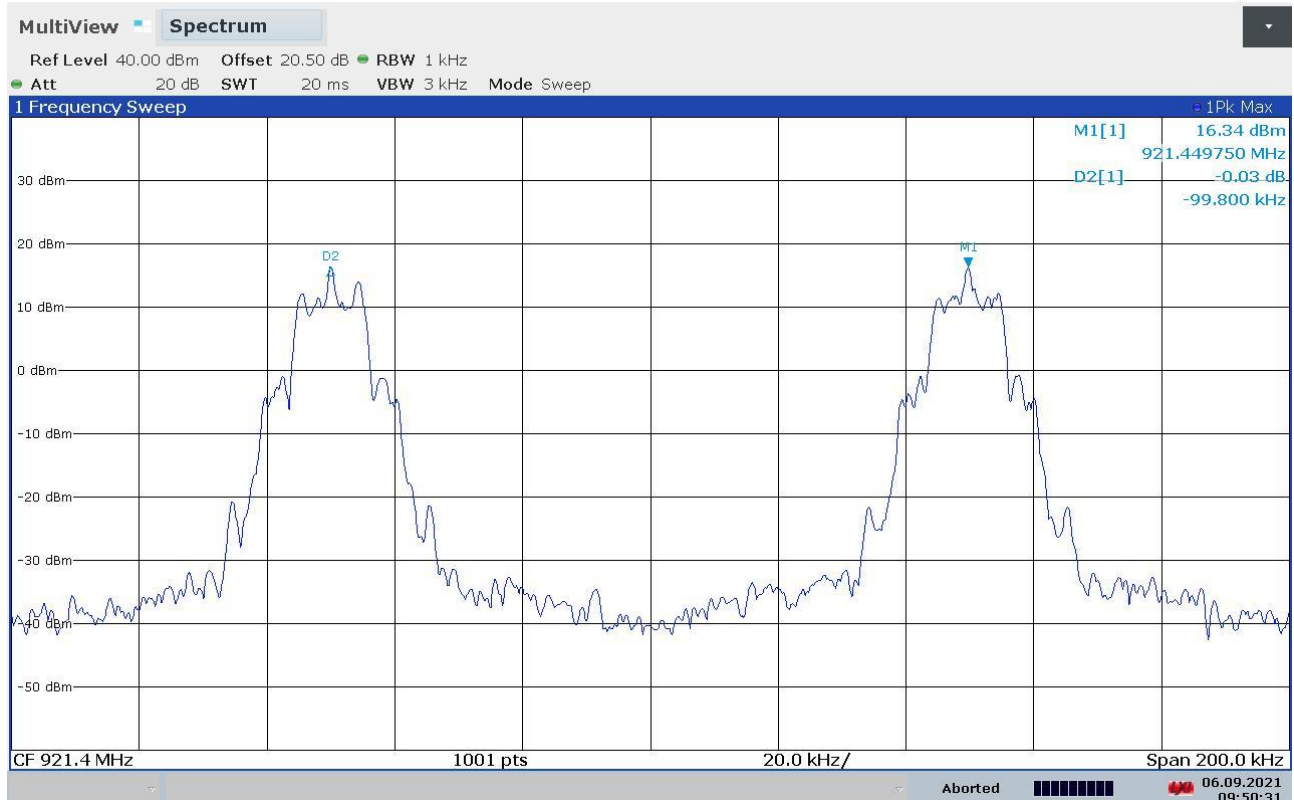

9.6 Number of hopping channels

Tested by	G. Gandini
Test date	06.09.2021
Test location (stand)	Laboratory
Reference standards	FCC Rules and Regulation; Titles 47 Part. 15.247 KDB 558074 D01 15.247 Meas Guidance v05r02 cl. 9 b) ANSI C63.10 cl. 7.8.3
Supplementary test set-up description	--
Supplementary information.....	--

Acceptance limits

For frequency hopping systems operating in the 902 – 928 MHz band: if the 20 dB bandwidth of the hopping channel is less than 250 kHz, the system shall use at least 50 hopping frequencies and the average time of occupancy on any frequency shall not be greater than 0,4 seconds within a 20 second period; if the 20 dB bandwidth of the hopping channel is 250 kHz or greater, the system shall use at least 25 hopping frequencies and the average time of occupancy on any frequency shall not be greater than 0,4 seconds within a 10 second period. The maximum allowed 20 dB bandwidth of the hopping channel is 500 kHz.

Test setup

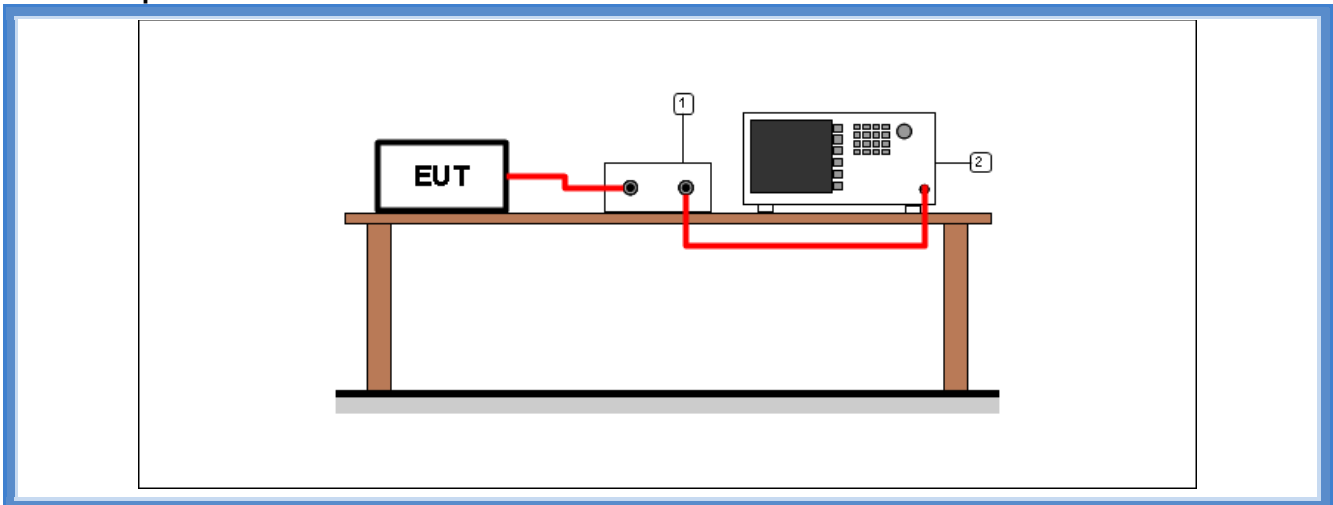

Test setup PR002_01

Nr.	Id. Number	Manufacturer	Model	Description
2	CMC S295	Rohde & Schwarz	FSW43	Spectrum Analyzer 43GHz
1	--	--	--	Cable + attenuator (calibrated before the test)

Result

<i>Frequency band (MHz)</i>	<i>Graphs</i>	<i>Number of hopping channels</i>	<i>Minimum number of hopping channels required</i>	<i>Results</i>
902 – 928	G21097249	128	50	Complies
	G21097250	32		
	G21097251	32		
	G21097252	32		
	G21097253	32		

Graphs

Gandini 21097249

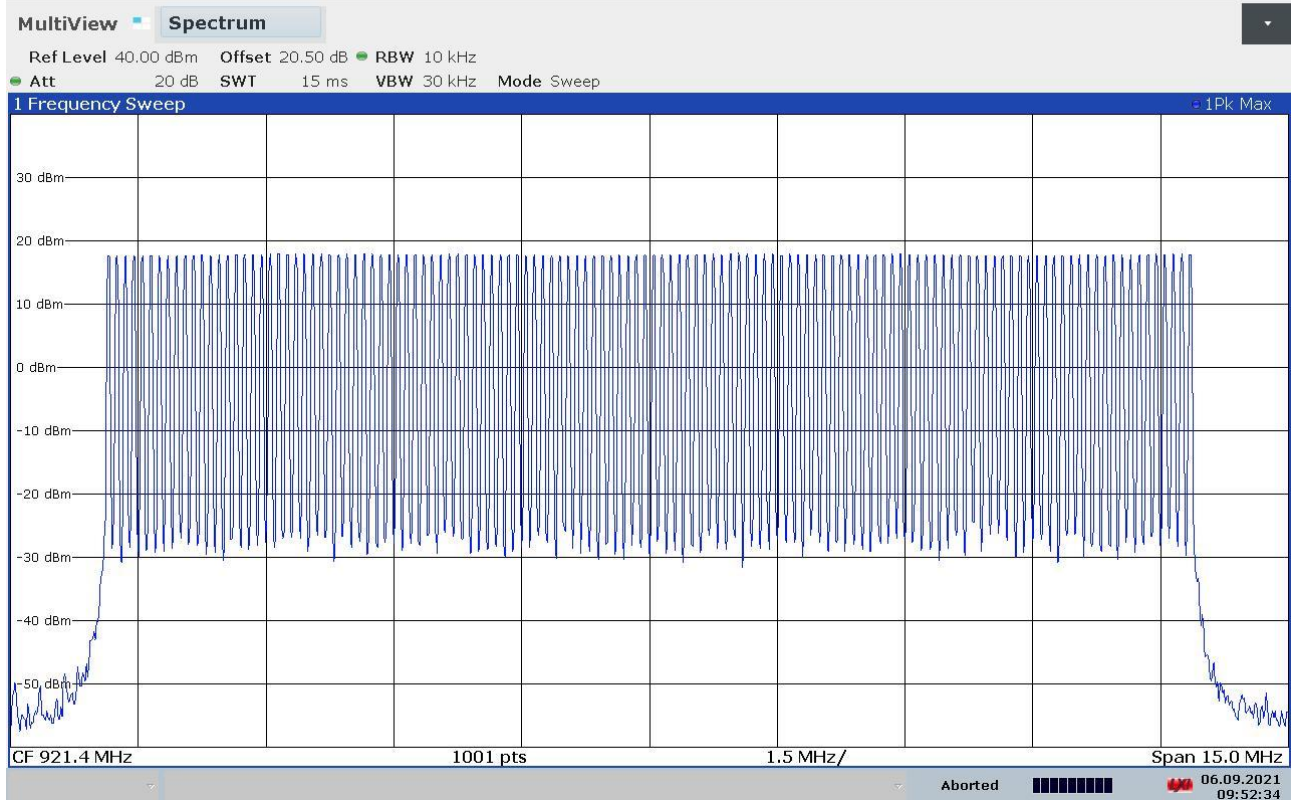

Gandini 21097250

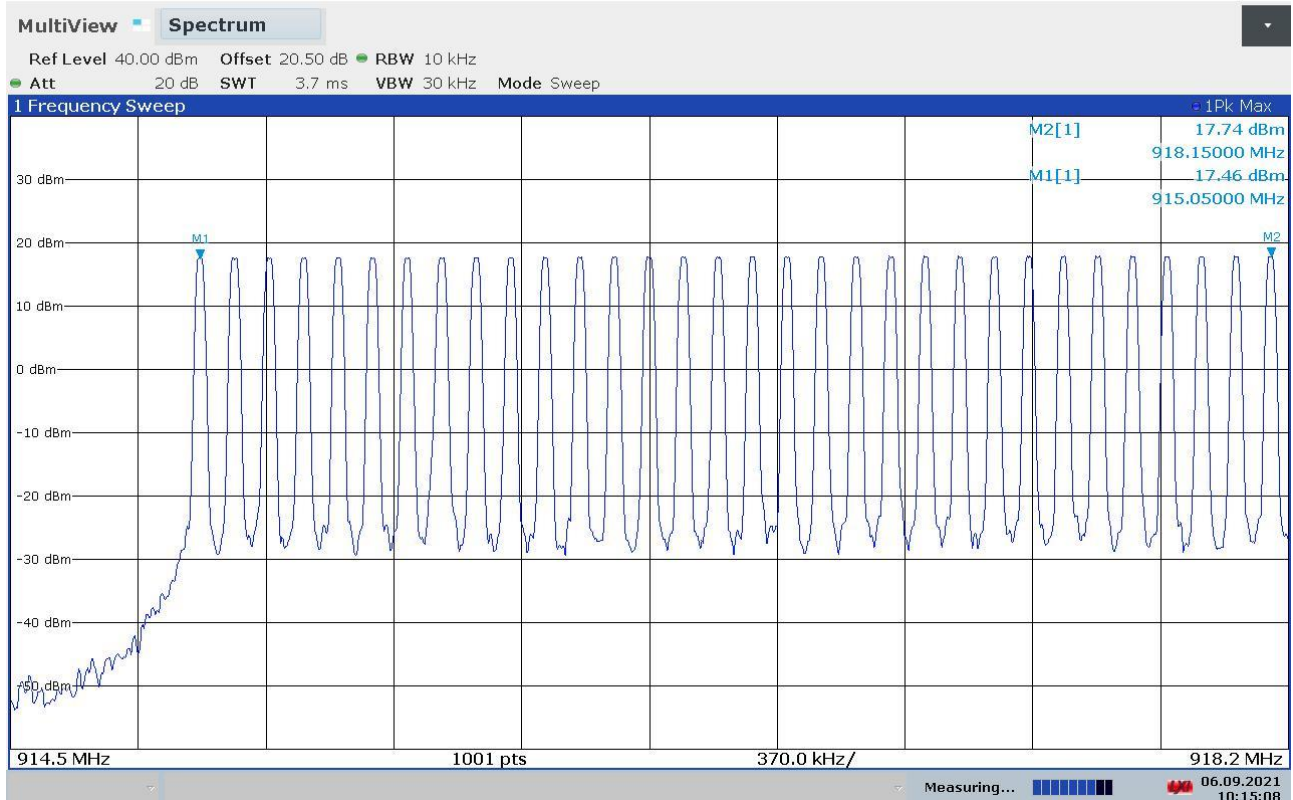

Gandini 21097251

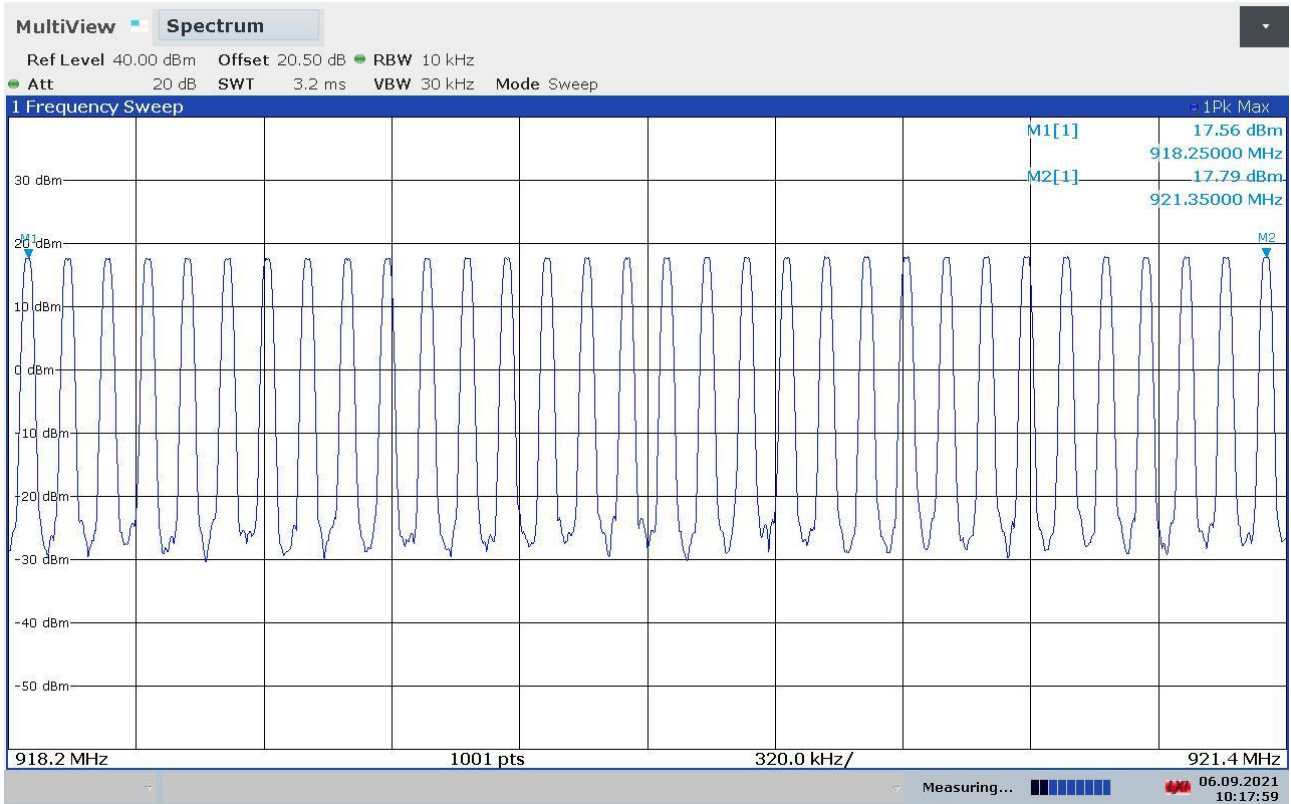

Gandini 21097252

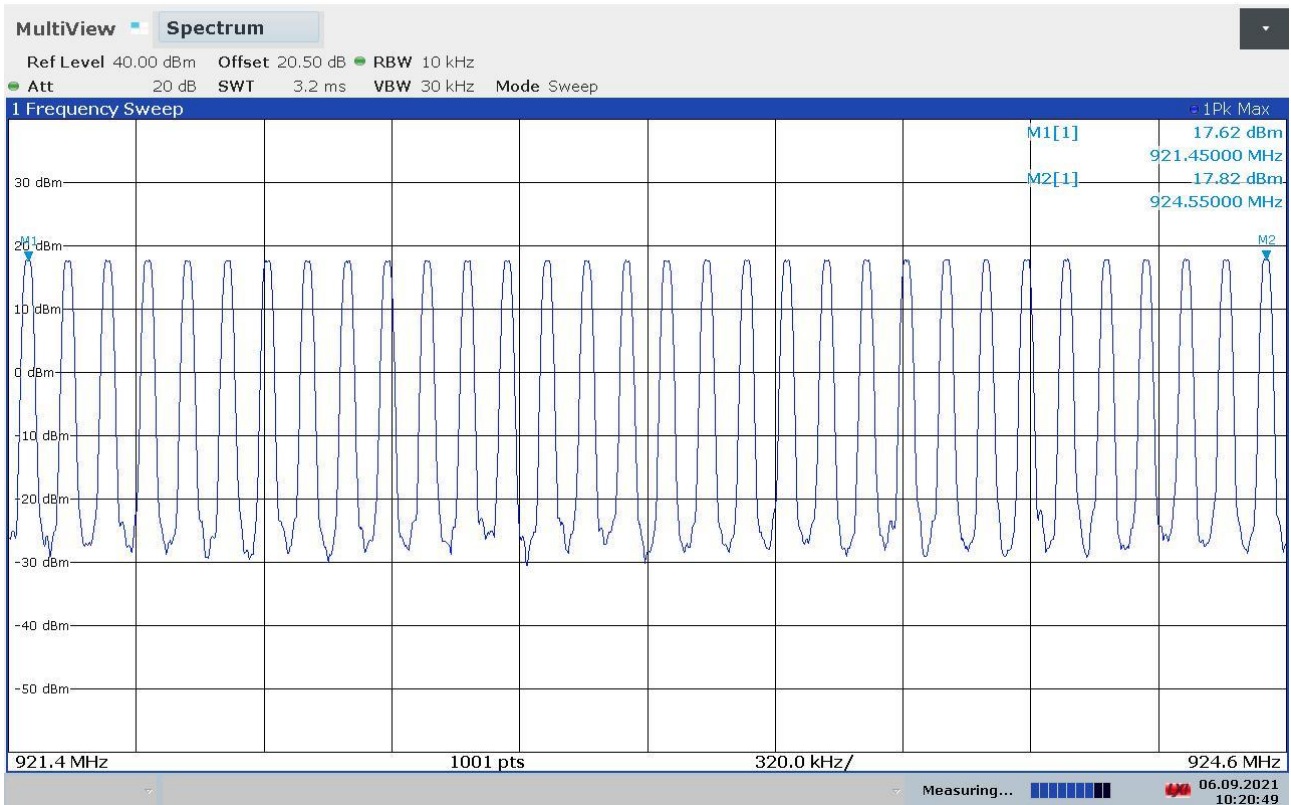

Gandini 21097253

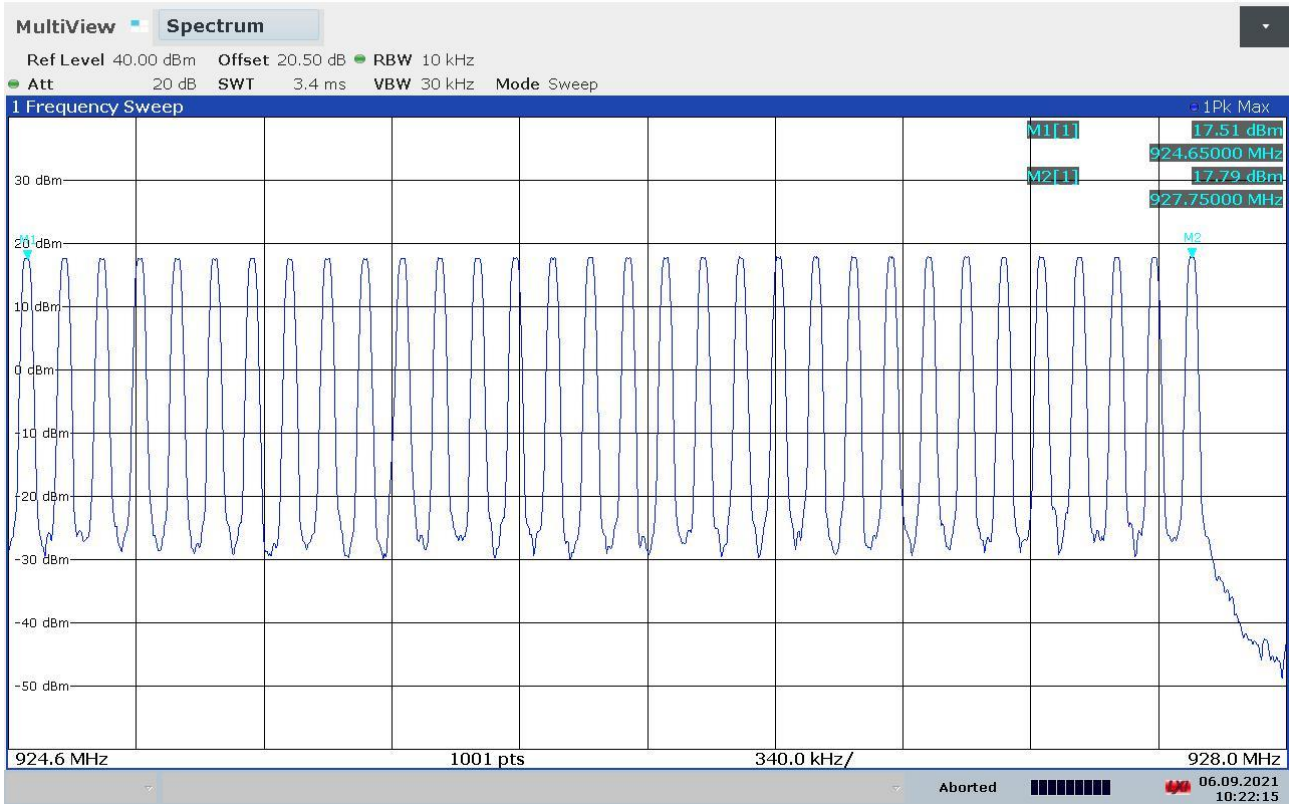

9.7 Time of occupancy

Tested by	G. Gandini
Test date	06.09.2021
Test location (stand)	Laboratory
Reference standards	FCC Rules and Regulation; Titles 47 Part. 15.247 KDB 558074 D01 15.247 Meas Guidance v05r02 cl. 9 b) ANSI C63.10 cl. 7.8.4
Supplementary test set-up description	--
Supplementary information.....	--

Acceptance limits

For frequency hopping systems operating in the 902 – 928 MHz band: if the 20 dB bandwidth of the hopping channel is less than 250 kHz, the system shall use at least 50 hopping frequencies and the average time of occupancy on any frequency shall not be greater than 0,4 seconds within a 20 second period; if the 20 dB bandwidth of the hopping channel is 250 kHz or greater, the system shall use at least 25 hopping frequencies and the average time of occupancy on any frequency shall not be greater than 0,4 seconds within a 10 second period. The maximum allowed 20 dB bandwidth of the hopping channel is 500 kHz.

Test setup

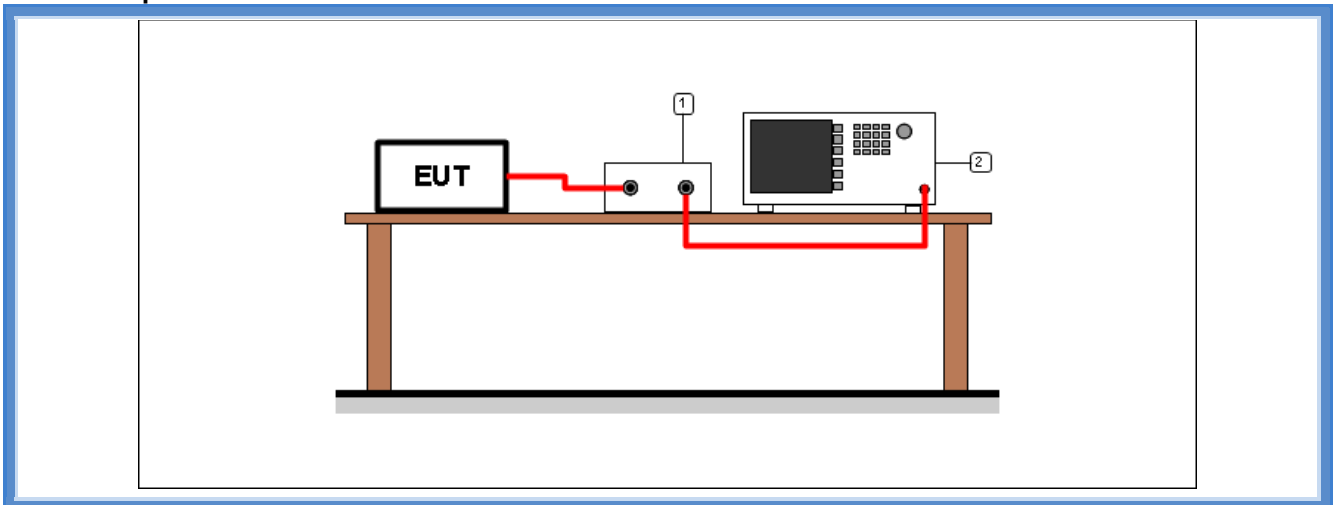

Test setup PR002_01

Nr.	Id. Number	Manufacturer	Model	Description
2	CMC S295	Rohde & Schwarz	FSW43	Spectrum Analyzer 43GHz
1	--	--	--	Cable + attenuator (calibrated before the test)

Result

<i>Frequency (MHz)</i>	<i>Graphs</i>	<i>Dwell time (ms)</i>
921,45	G21097254	21

<i>Frequency (MHz)</i>	<i>Graphs</i>	<i>Number of transmissions</i>	<i>Period</i>
921,45	G21097255	4	20 s

Remarks: only the highest peaks have been considered. The lowest peaks are due to the auxiliary receiver unit

<i>Time of occupancy (Dwell time x Nr. transmissions)</i>	<i>Maximum allowed time of occupancy</i>	<i>Results</i>
84 ms	400 ms	Complies

Graphs

Gandini 21097254

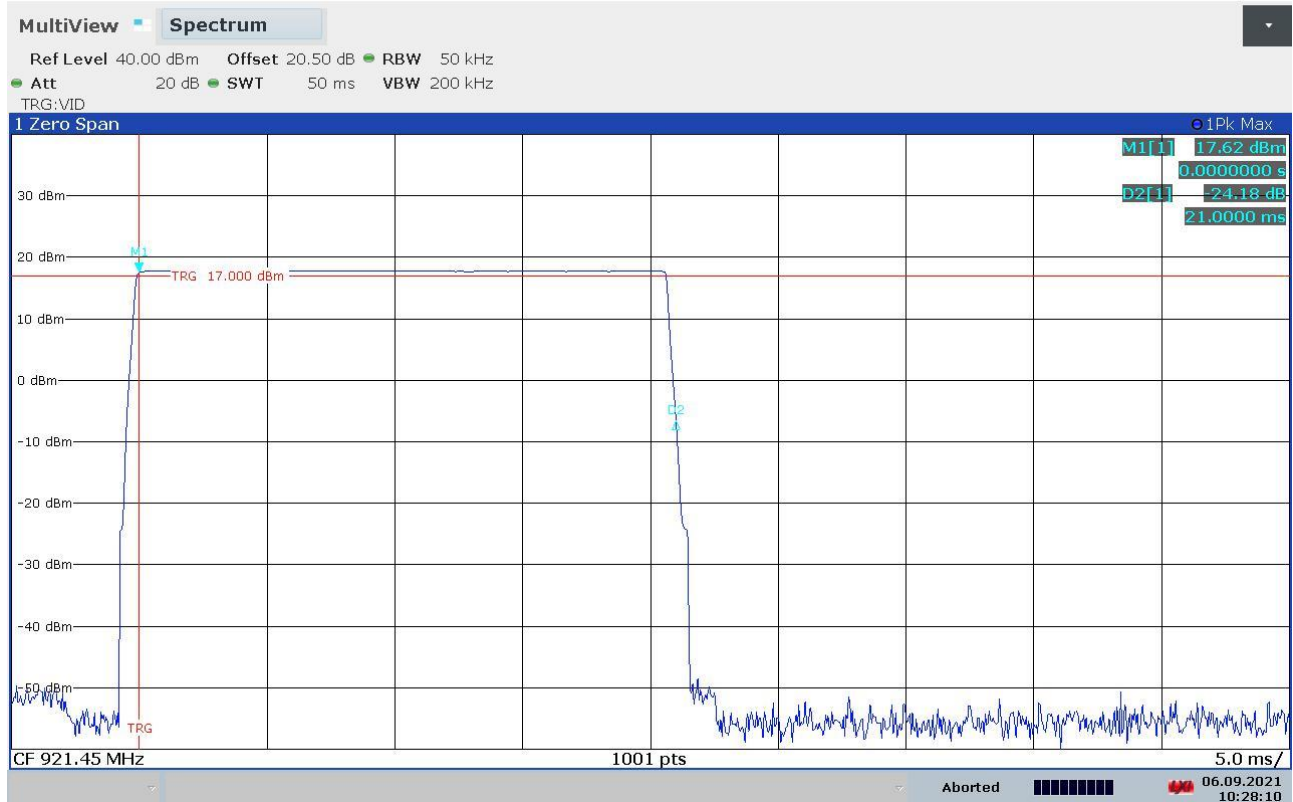

Gandini 21097255

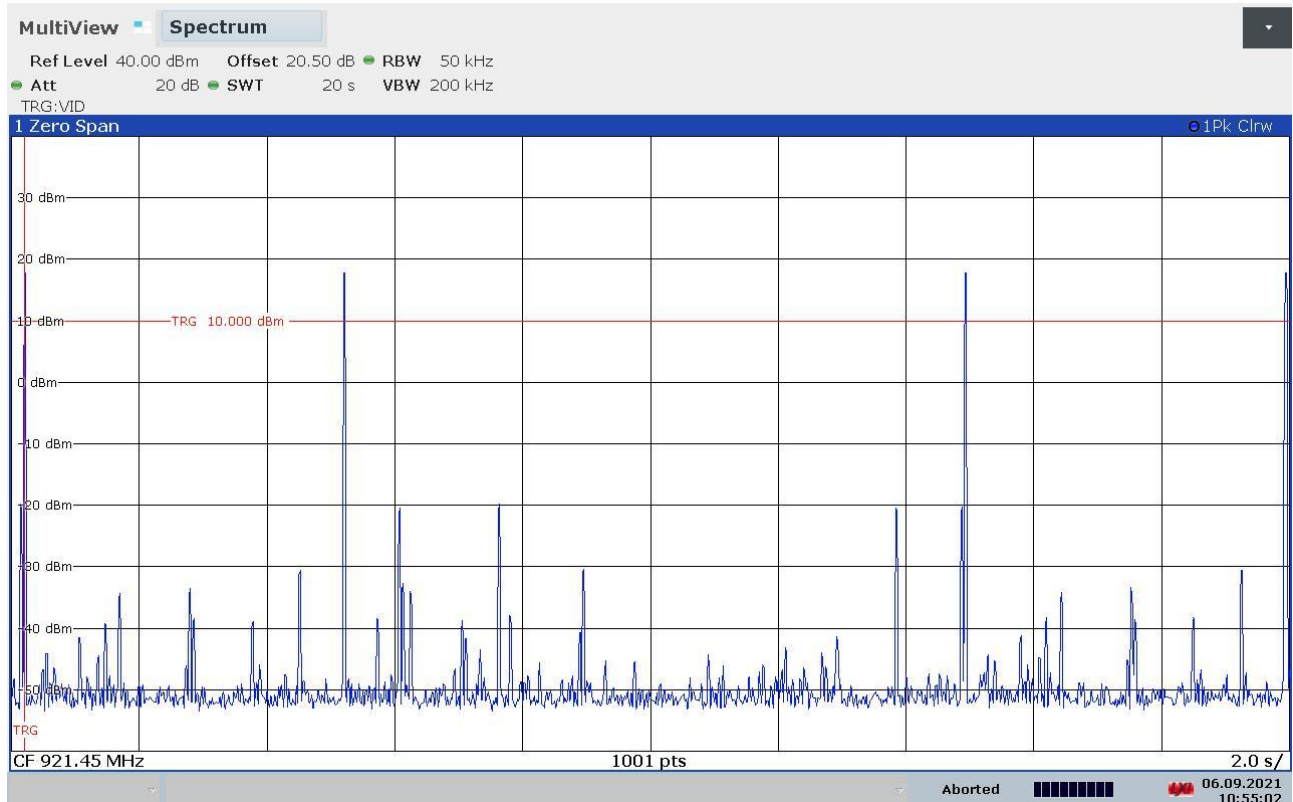

9.8 Band edge

Tested by	G. Gandini
Test date	06.09.2021
Test location (stand)	Laboratory
Reference standards	FCC Rules and Regulation; Titles 47 Part. 15.247 ANSI C63.10 cl. 7.8.6
Supplementary test set-up description	--
Supplementary information.....	--

Acceptance limits

In any 100 kHz bandwidth outside the frequency band in which the spread spectrum or digitally modulated intentional radiator is operating, the radio frequency power that is produced by the intentional radiator shall be at least 20 dB below that in the 100 kHz bandwidth within the band that contains the highest level of the desired power, based on either an RF conducted or a radiated measurement, provided the transmitter demonstrates compliance with the peak conducted power limits. If the transmitter complies with the conducted power limits based on the use of RMS averaging over a time interval, as permitted under paragraph (b)(3) of this section, the attenuation required under this paragraph shall be 30 dB instead of 20 dB. Attenuation below the general limits specified in § 15.209(a) is not required. In addition, radiated emissions which fall in the restricted bands, as defined in §15.205(a), must also comply with the radiated emission limits specified in § 15.209(a) (see § 15.205(c)).

Operation within the band 902 – 928 MHz

Test setup

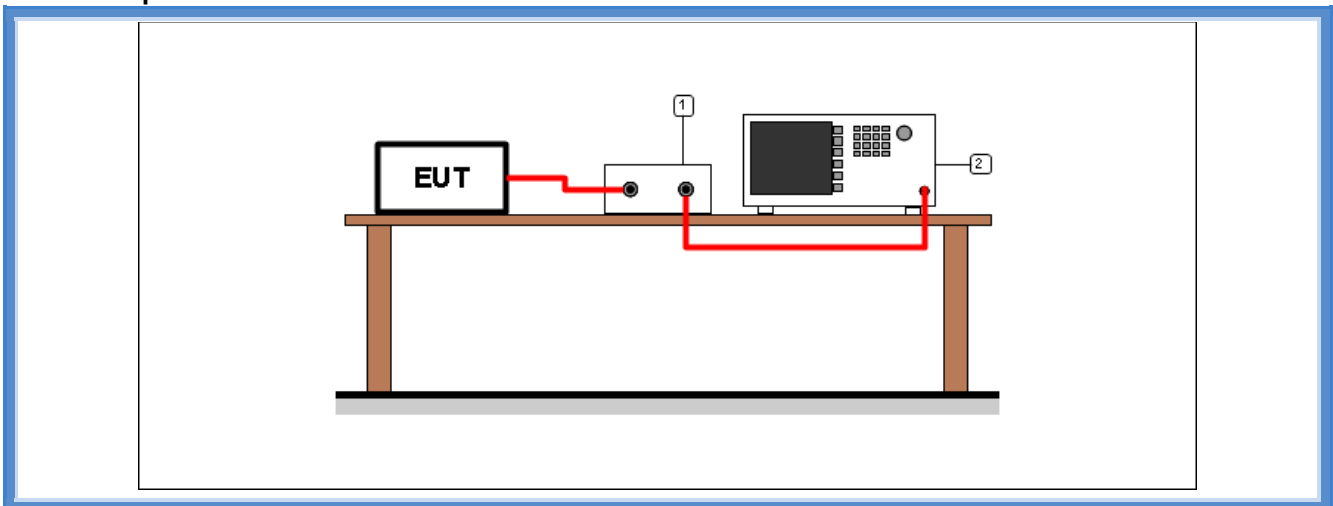

Test setup PR002_01

Nr.	Id. Number	Manufacturer	Model	Description
2	CMC S295	Rohde & Schwarz	FSW43	Spectrum Analyzer 43GHz
1	--	--	--	Cable + attenuator (calibrated before the test)

Result

Frequency (MHz)	Bandwidth	Graph(s) – Hopping	Results	
915,050	100 kHz	G21097256	F _L : 914,9121 MHz	Complies
	100 kHz	G21097257		
927,800	100 kHz	G21097258	F _H : 927,9439 MHz	Complies
	100 kHz	G21097259		

Frequency (MHz)	Bandwidth	Graph(s) – No hopping	Results	
915,050	100 kHz	G21097237	F _L : 914,9081 MHz	Complies
	100 kHz	G21097238		
927,800	100 kHz	G21097239	F _H : 927,9399 MHz	Complies
	100 kHz	G21097240		

Graphs

Gandini 21097237

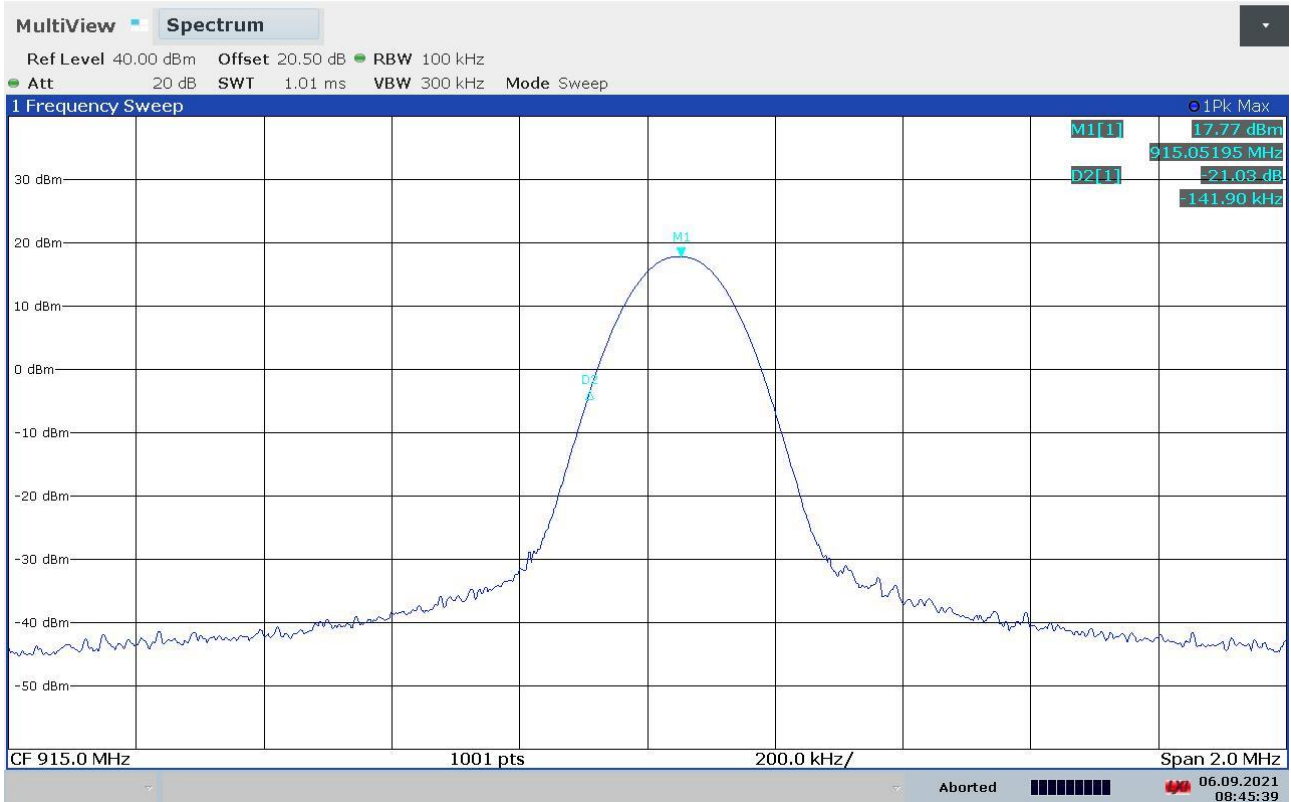

Gandini 21097238

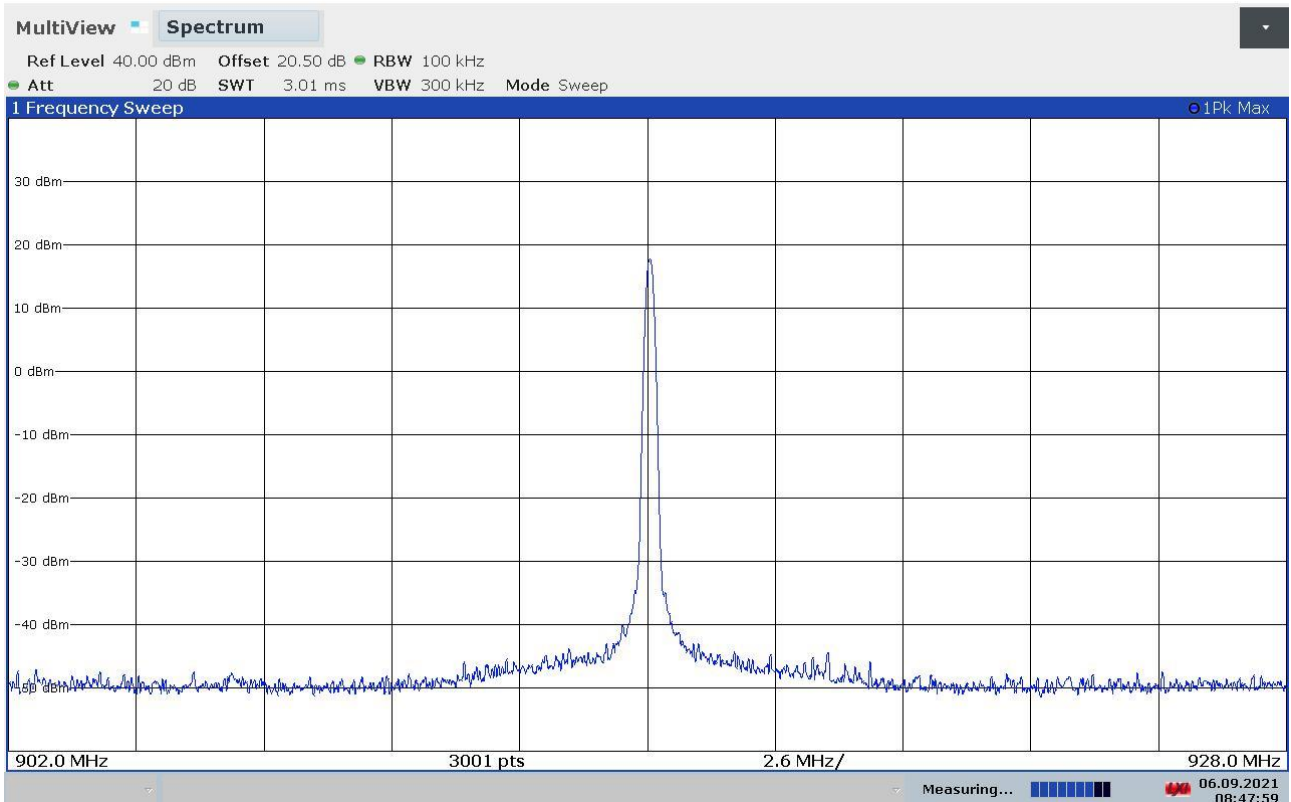

Gandini 21097239

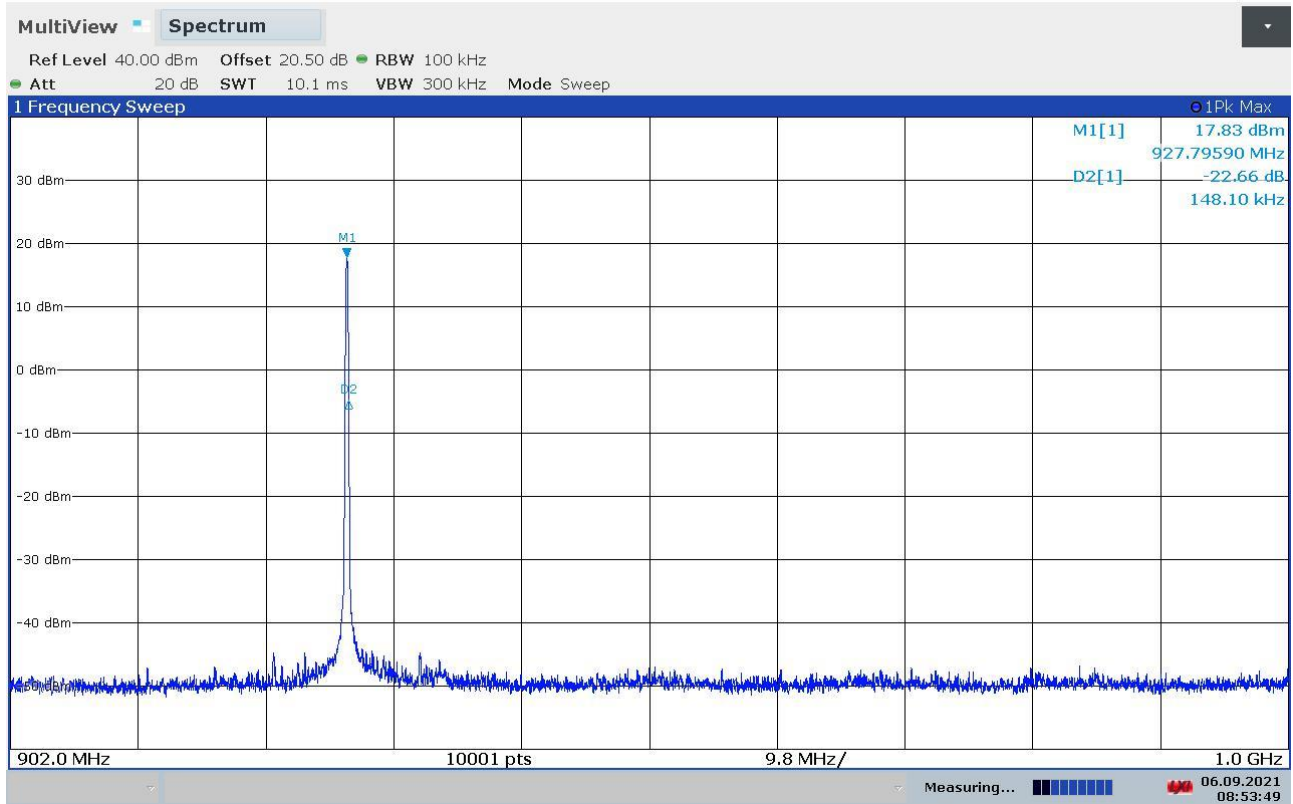

Gandini 21097240

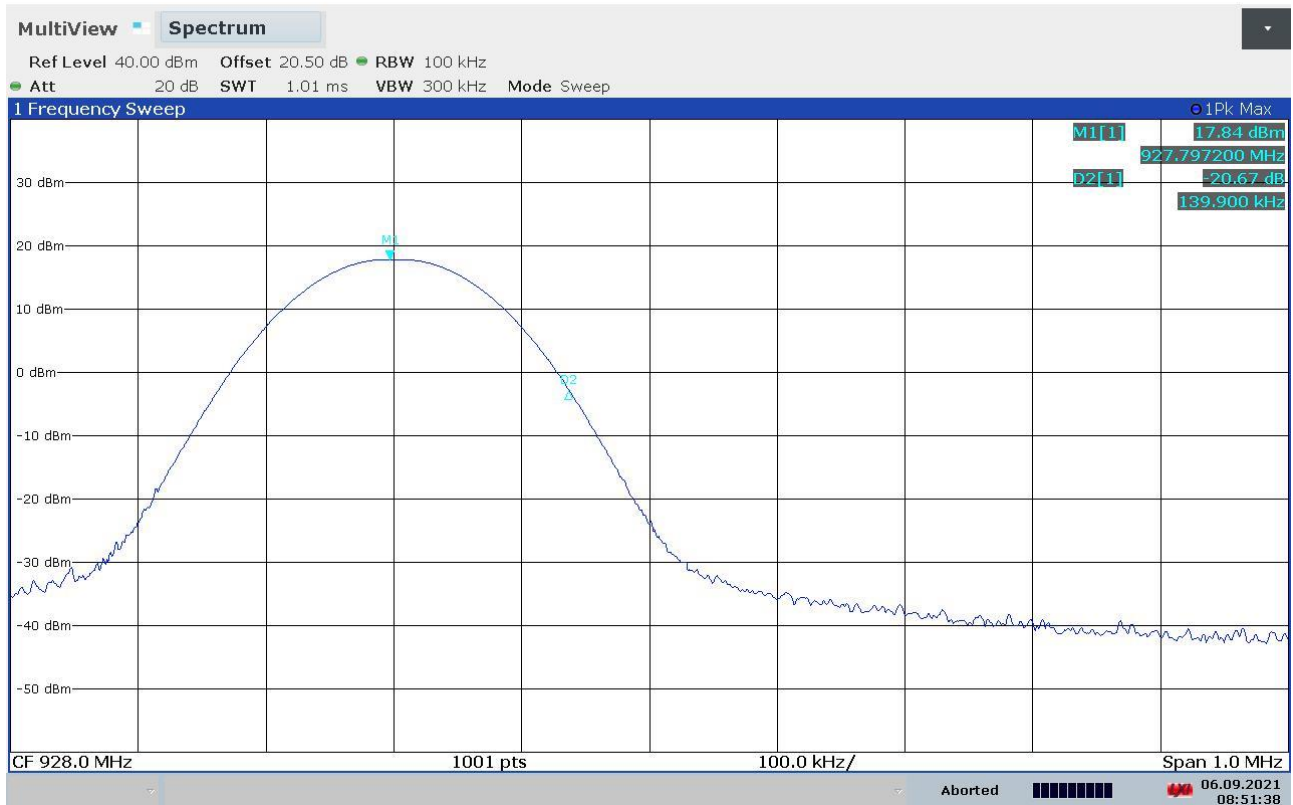

Gandini 21097256

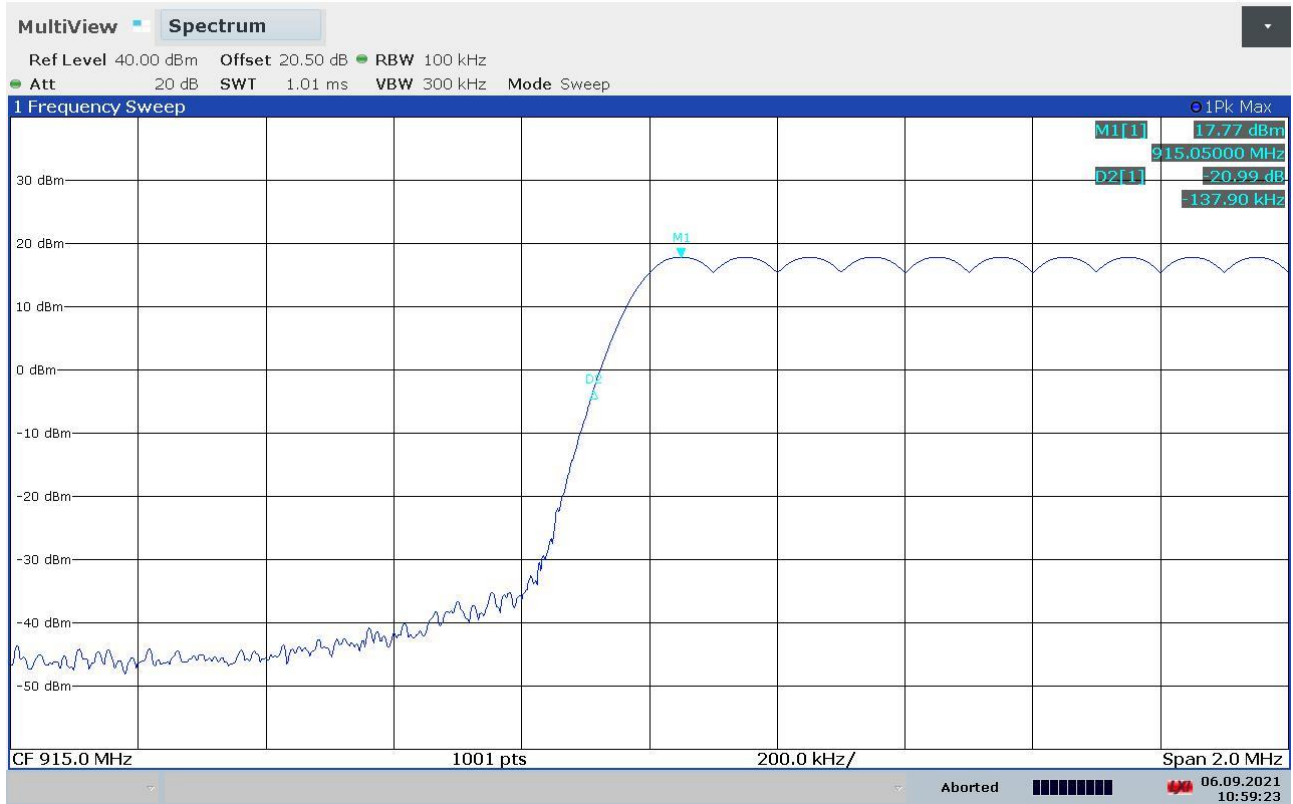

Gandini 21097257

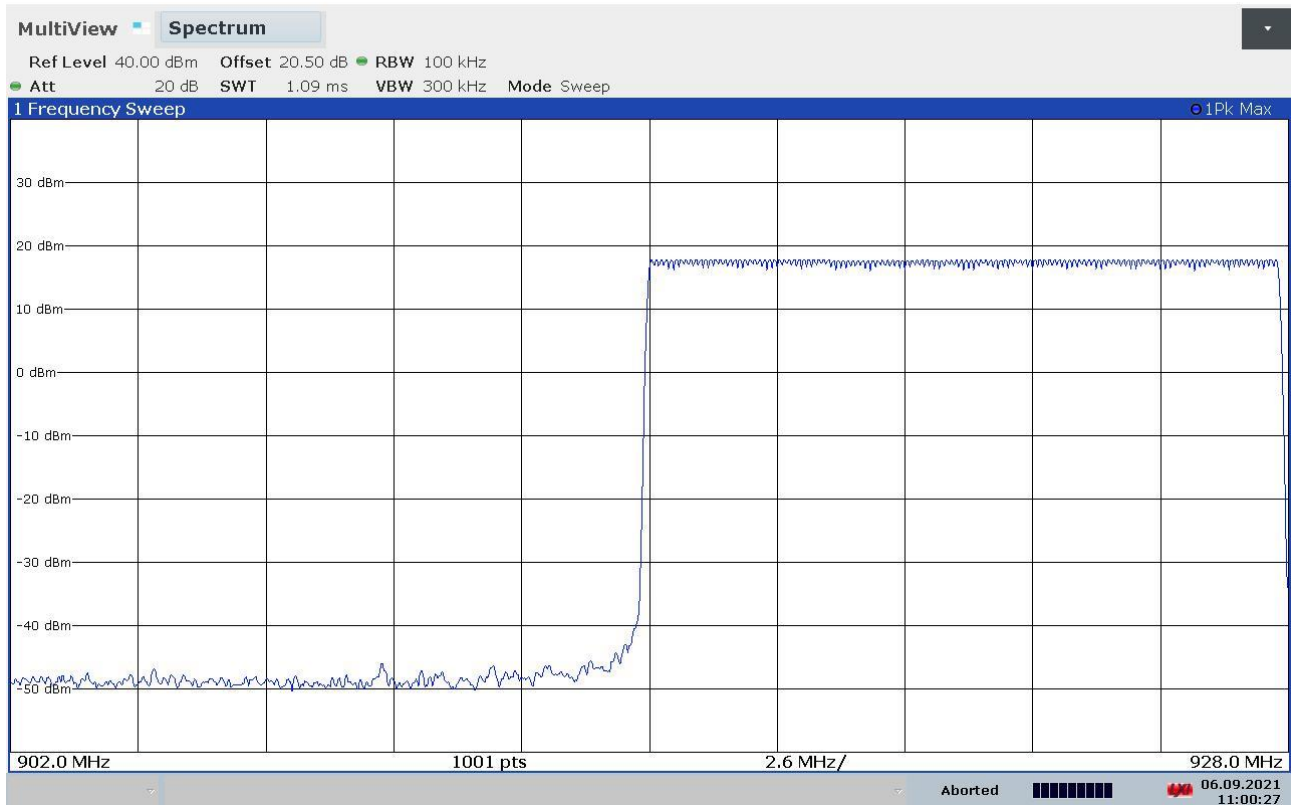

Gandini 21097258

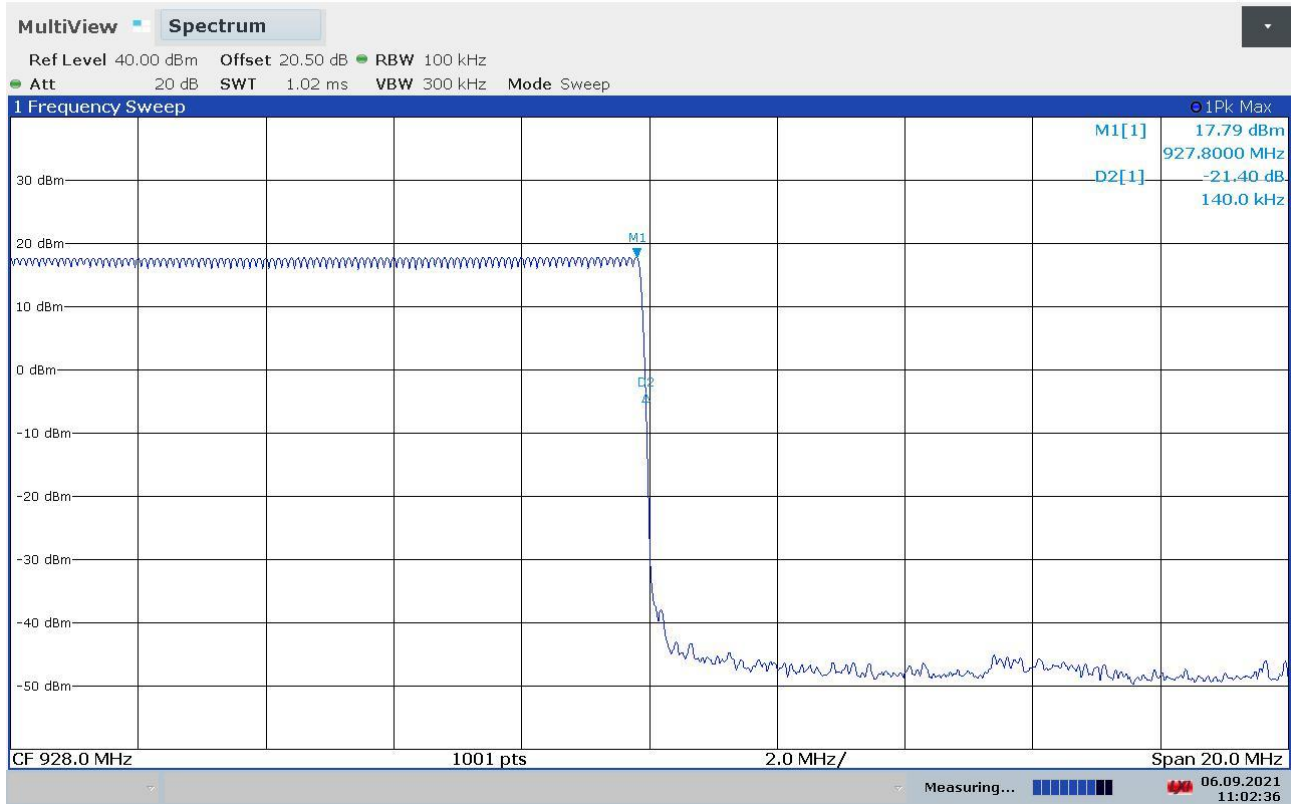

Gandini 21097259

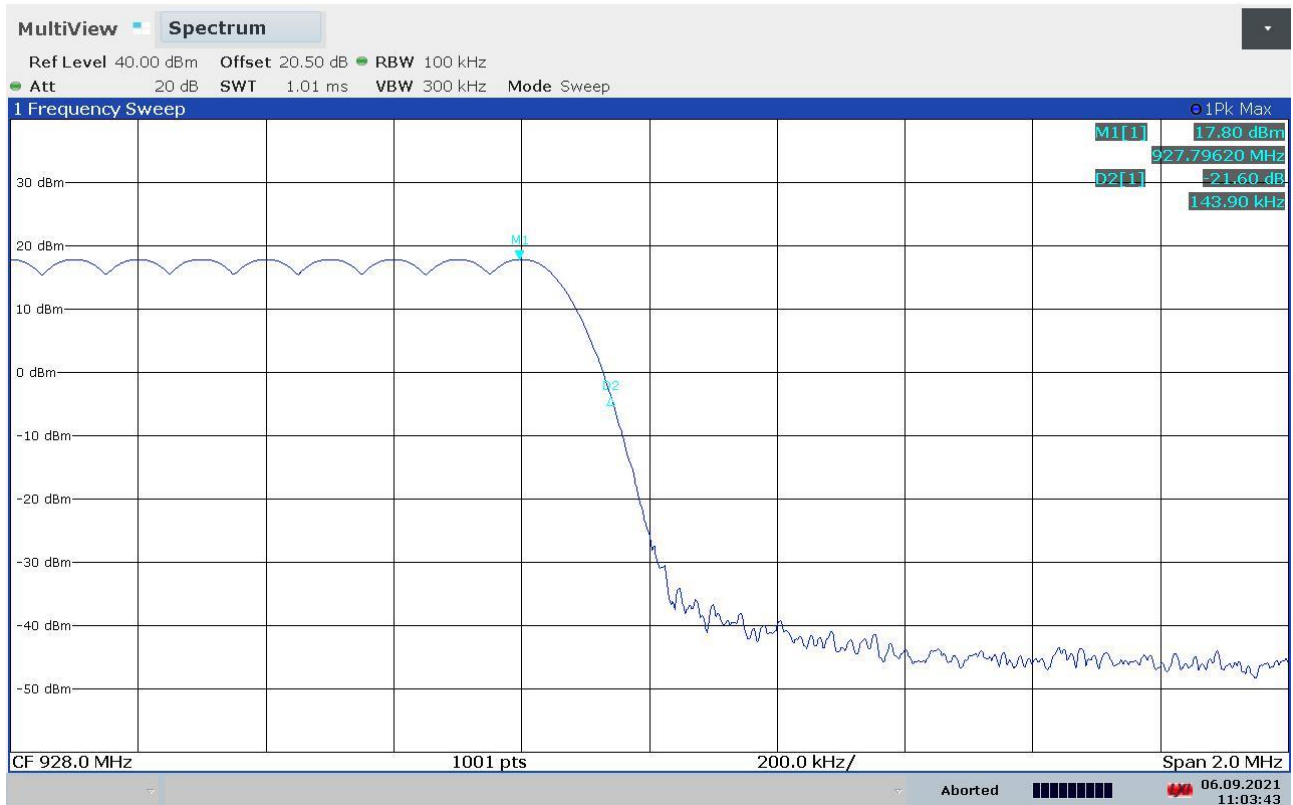

9.9 Peak Output Power

Tested by	G. Gandini
Test date	06.09.2021
Test location (stand)	Laboratory
Reference standards	FCC Rules and Regulation; Titles 47 Part. 15.247 KDB 558074 D01 15.247 Meas Guidance v05r02 cl. 2.2 ANSI C63.10 cl. 7.8.5
Supplementary information.....	--

Acceptance limits

For frequency hopping systems operating in the 902–928 MHz band: 1 watt for systems employing at least 50 hopping channels; and, 0,25 watts for systems employing less than 50 hopping channels, but at least 25 hopping channels

Test setup

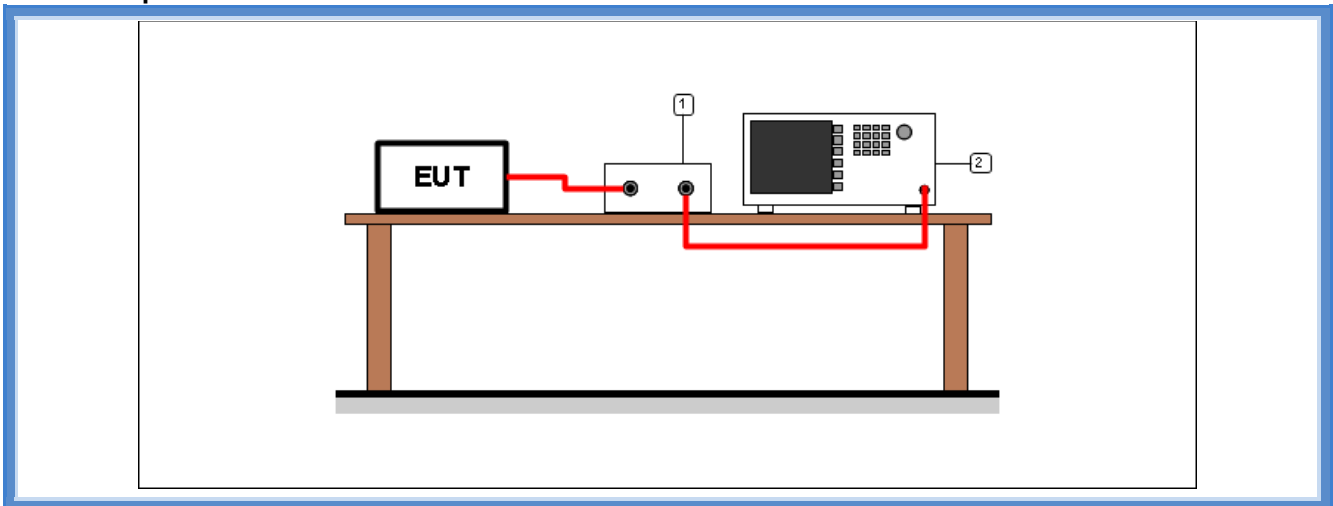

Test setup PR002_01				
Nr.	Id. Number	Manufacturer	Model	Description
2	CMC S295	Rohde & Schwarz	FSW43	Spectrum Analyzer 43GHz
1	--	--	--	Cable + attenuator (calibrated before the test)

Result

<i>Frequency (MHz)</i>	<i>Graphs</i>	<i>Peak Output Power (dBm)</i>	<i>Peak Output Power (mW)</i>	<i>Limit (mW)</i>
915,050	G21097236	17,78	59,98	1000
921,400	G21097246	17,76	59,70	1000
927,800	G21097241	17,83	60,67	1000

Graphs

Gandini 21097236

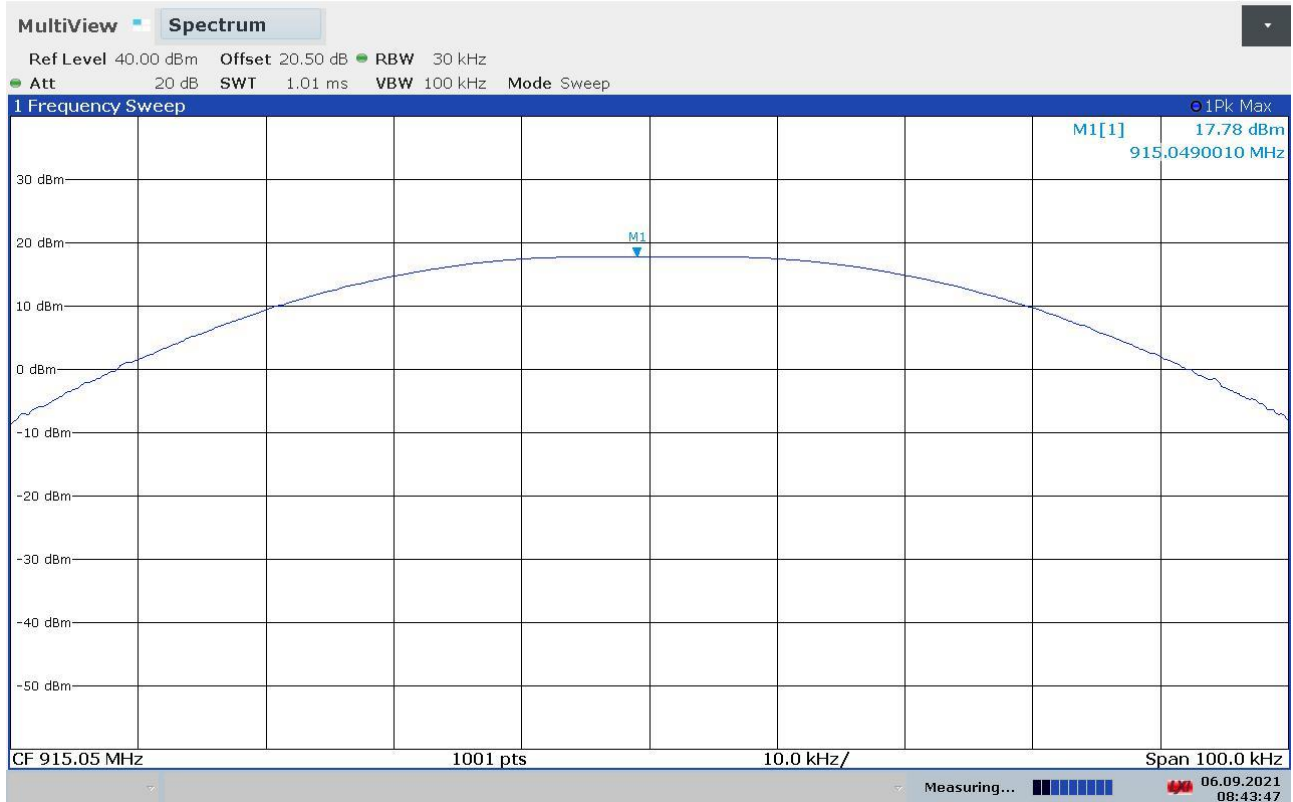

Gandini 21097241

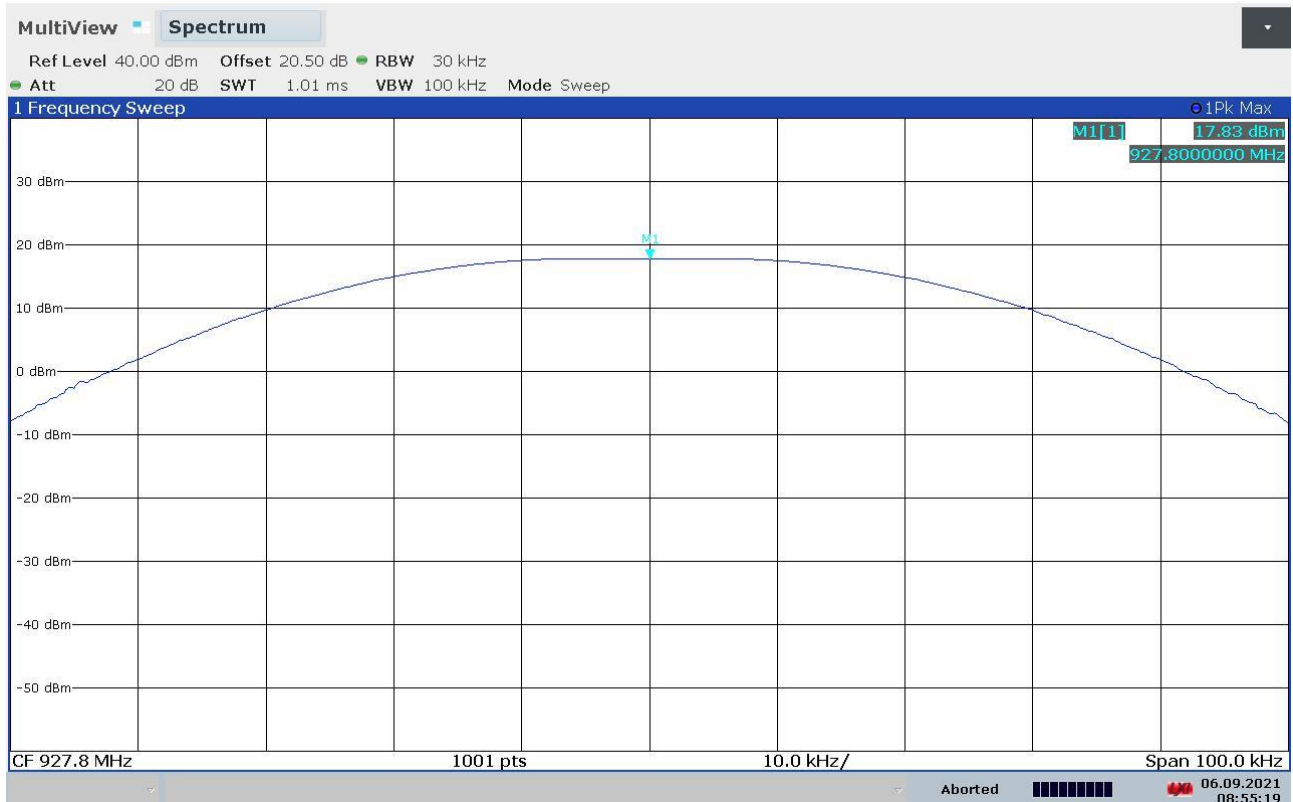

Gandini 21097246

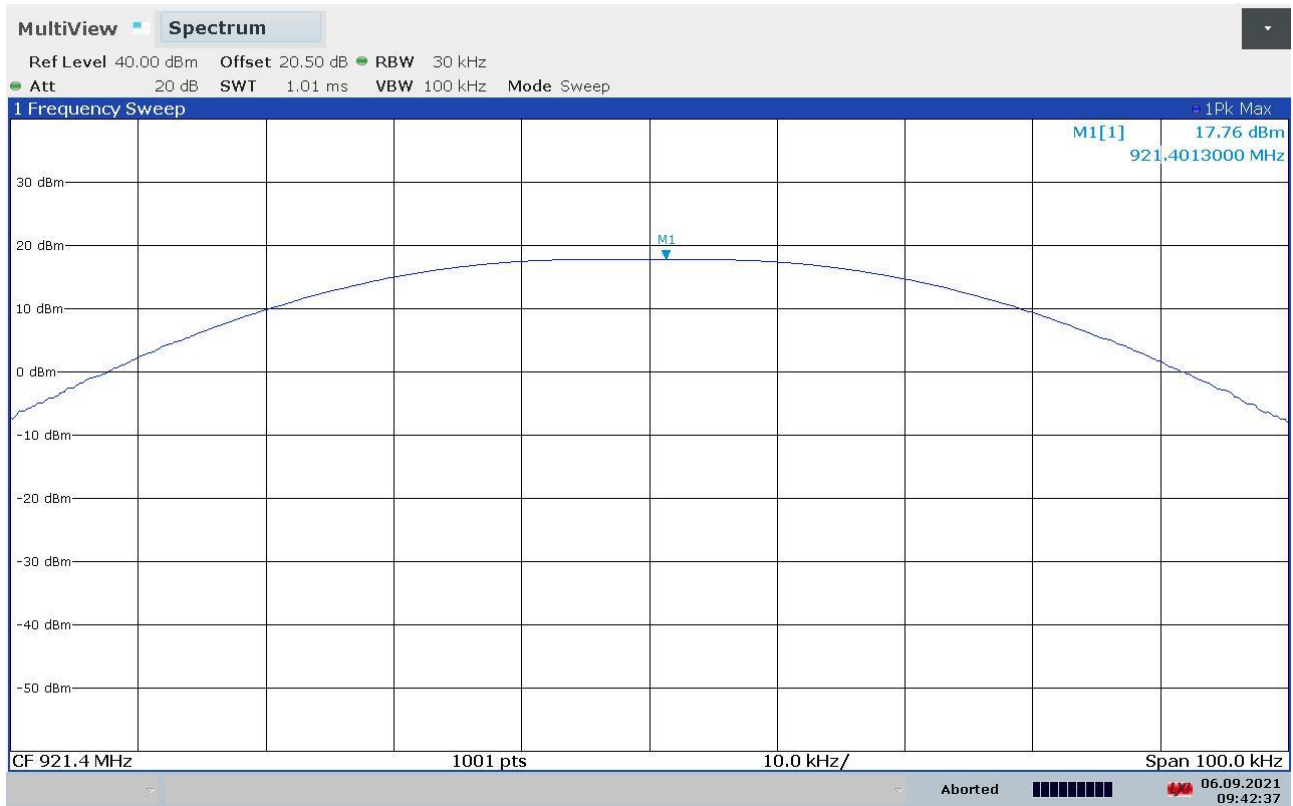

Attachment 1
Instruments list

<i>Id. number</i>	<i>Manufacturer</i>	<i>Model</i>	<i>Description</i>	<i>Serial number</i>	<i>Last calibration</i>	<i>Due date calibration</i>
CMC S010	Rohde & Schwarz	ESH3-Z2	Impulses Limiting Device	- - -	January '21	January '22
CMC S108	EMCO	3115	Horn Antenna	9811-5622	June '19	June '22
CMC S127	Schaffner	HLA6120	Loop Antenna	1191	November '18	November '23
CMC S200	Schwarzbeck	NSLK 8128	V-LISN	8128-273	January '21	January '22
CMC S206	Rohde & Schwarz	ESCI 7	EMC Receiver 9KHz-7GHz	100781	January '21	January '22
CMC S260	CMC	Wfr_N	Shielded Cable	Wfr_ant10-1	November '20	November '21
CMC S261	CMC	Wfr_N	Shielded Cable	Wfr_ant20-1	November '20	November '21
CMC S262	CMC	Wfr_N_fix	Shielded Cable	Wfr_fix32-1	November '20	November '21
CMC S263	CMC	Wfr_N_fix	Shielded Cable	Wfr_fix31-1	November '20	November '21
CMC S264	CMC	Wfr_N	Shielded Cable	Wfr_ext03-1	November '20	November '21
CMC S271	Schwarzbeck	BBA 9106 + VHBB 9124	Biconical Antenna (30-300MHz)	831	June '19	June '22
CMC S287	Schwarzbeck	VUSLP 9111B	Log-periodic Antenna (200 MHz-3GHz)	9111B-203	June '19	June '22
CMC S288	CMC	W_sma_white	Joint Shielded Cable	W_001	November '20	November '21
CMC S295	Rohde & Schwarz	FSW43	Spectrum Analyzer 43GHz	104059	November '19	November '22
CMC S353	Rohde & Schwarz	ESW26	Emi Test Receiver 1 Hz - 26.5 GHz	101492	September '20	September '22

Attachment 1
Measurement uncertainty

<i>Test</i>	<i>Test Setup</i>	<i>Expanded uncertainty</i>	<i>Note</i>
Conducted emission CISPR 16 LISN 50uH 0,009-0,0150 MHz	PE001_01	3,4 dB	1
Conducted emission CISPR 16 LISN 50uH 0,150-30,0 MHz	PE001_01	3,0 dB	1
Conducted emission CISPR 16 Voltage Probe 0,15-30 MHz	PE001_02	2,3 dB	1
Conducted emission CISPR 16 Current Probe 0,15-30 MHz	PE001_03	2,6 dB	1
Conducted emission CISPR 16 ISN 0,15-30 MHz	PE001_04	4,7 dB	1
Clic CISPR 16 LISN 50uH 0,150-30,0 MHz	PE001_05	2,9 dB	1
Radiated Emission CDNE 30-300 MHz	PE001_06	3,3 dB	1
Disturbance Power 30-300 MHz	PE002_01	3,8 dB	1
Radiated Emission LAS 0,15-30 MHz	PE003_01	2,0 dB	1
Radiated Emission CISPR 16 Loop Ant. 0,15-30 MHz	PE004_01	4,2 dB	1
Radiated Emission CISPR 16 Bicon. Ant. 30-300 MHz	PE004_02	4,1 dB	1
Radiated Emission CISPR 16 LogP. Ant. 300-1000 MHz	PE004_03	3,9 dB	1
Radiated Emission CISPR 16 Horn Ant. 1-18 GHz	PE004_04	4,1 dB	1
Human Exposure to electromagnetic fields	PE005_01	16,7 %	1
Harmonics	PE006_01	10 mA + 2,9 %	1
Flicker	PE007_01	4,36 %	1
Radiated Immunity 80 MHz - 6 GHz	PE102_XX	2,20 dB 0,87 V/m a 3V/m	1
Conducted Immunity 0,15 - 230 MHz	PE105_XX	1,20 dB 0,44 V a 3V	1
AC Magnetic field	PE106_01	1,55 % 0,15 A/m a 10A/m	1
Pulse Magnetic field	PE107_01	6,23 % 18,7 A/m a 300A/m	1
Dumped Magnetic field	PE108_01	6,23 % 1,87 A/m a 30A/m	1
Common mode conducted immunity	PE112_01	2,16 % 0,22 V a 10V	1

Attachment 1

<i>Test</i>	<i>Test Setup</i>	<i>Expanded uncertainty</i>	<i>Note</i>
Power/Spurious 9kHz-30MHz	PR001_01	4,2 dB	1
Power/Spurious ERP 30-1000MHz d=10m	PR001_02+03	4,7 dB	1
Misura della potenza EIRP 1-18GHz d=3m	PR001_04+05	4,7 dB	1
Misura della potenza EIRP 18-40GHz d=3m	PR001_06	5,4 dB	1
Frequency error	PR002_01+02	< 1x10 ⁻⁷	1
Timing zero span (1001pts.)	PR002_01+02	0,2 % SWT	1
Modulation bandwidth	PR002_01+02	< 1x10 ⁻⁷	1
Conducted RF power and spurious emission	PR002_01+02	1,1 dB	1
Adjacent channel power	PR002_01+02	1,1 dB	1
Blocking	PR002_01+02	1,1 dB	1

<i>Test</i>	<i>Test Setup</i>	<i>Expanded uncertainty</i>	<i>Note</i>
Electrostatic discharge immunity test	PE101_0X		2
Electrical fast transients / burst immunity test	PE103_0X		2
Surge immunity test	PE104_0X		2
Short interruption immunity test	PE109_01		2
Ring Wave immunity test	PE110_01		2
Low frequency immunity test	PE111_01		2
Dumped Oscillatory immunity test	PE113_01		2
<i>Rev_21_01 date 23/02/2021</i>			

Note 1:



The expanded uncertainty reported according to the document EA-4-02 is based on a standard uncertainty multiplied by a coverage factor of k=2, providing a level of confidence of p = 95%

Note 2:

It has been demonstrated that the used test equipment meets the specified requirements in the standard with at least a 95% confidence, covering factor k=2

Attachment 1

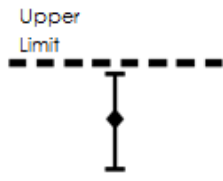
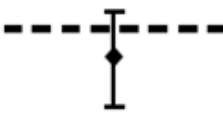
Judgement of compliance

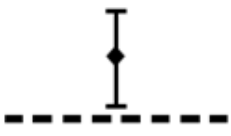
Case 1	Case 2	Case 3	Case 4
 <p>The sample complies with the requirements.</p> <p>The measurement results is within the specification limit when the measurement uncertainty is taken into account.</p>	 <p>The sample complies with the requirements.</p> <p>It is not possible to state compliance using a 95% coverage probability for the expanded uncertainty although the measurement result is below the limit.</p>	 <p>The sample does not comply with the requirements.</p> <p>It is not possible to state compliance using a 95% coverage probability for the expanded uncertainty also the measurement result is upper the limit.</p>	 <p>The sample does not comply with the requirements.</p> <p>The measurement results is outside the specification limit when the measurement uncertainty is taken into account.</p>

In agreement with ILAC-G8:09/2019 cl.4.2.1 Guidelines on Decision Rules and Statements of Conformity

Quality manual references – Internal procedure

Internal Procedure PM001 rev. 3.1 (Quality Manual)	Measure procedure
Internal Procedure INC_M rev. 9.5 (Quality Manual)	Measurement uncertainty calculation