

Gandini 21162709

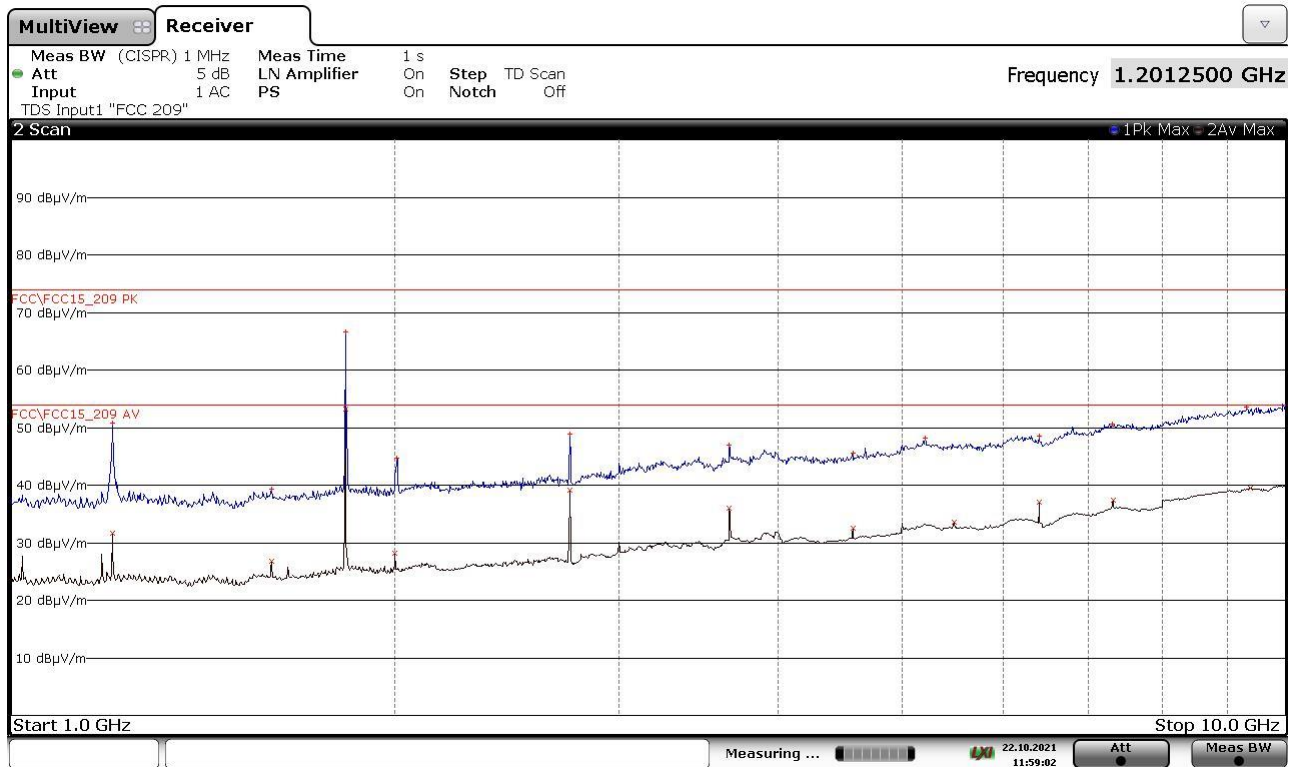

FINAL RESULT TABLE

MAX PEAK			AVERAGE		
Freq Hz	Lev dBuV/m	Margin dB	Freq Hz	Lev dBuV/m	Margin dB
1199750000	+50,82	-23,16	1200000000	+31,65	-22,33
1599750000	+39,30	-34,68	1599750000	+26,85	-27,13
1830250000	+66,62	-7,36	1830250000	+53,28	-0,70
2008250000	+44,64	-29,34	2000000000	+28,11	-25,87
2745250000	+48,86	-25,12	2745250000	+39,18	-14,80
3660250000	+46,89	-27,09	3660250000	+36,07	-17,91
4575250000	+45,61	-28,37	4575250000	+32,46	-21,52
5211250000	+48,12	-25,86	5490500000	+33,64	-20,34
6405500000	+48,52	-25,46	6405500000	+37,02	-16,96
7312500000	+50,67	-23,31	7320500000	+37,36	-16,62
9320500000	+53,49	-20,49	9382000000	+39,47	-14,51

21192709\_2

De Rosso 21192710 horiz 3m

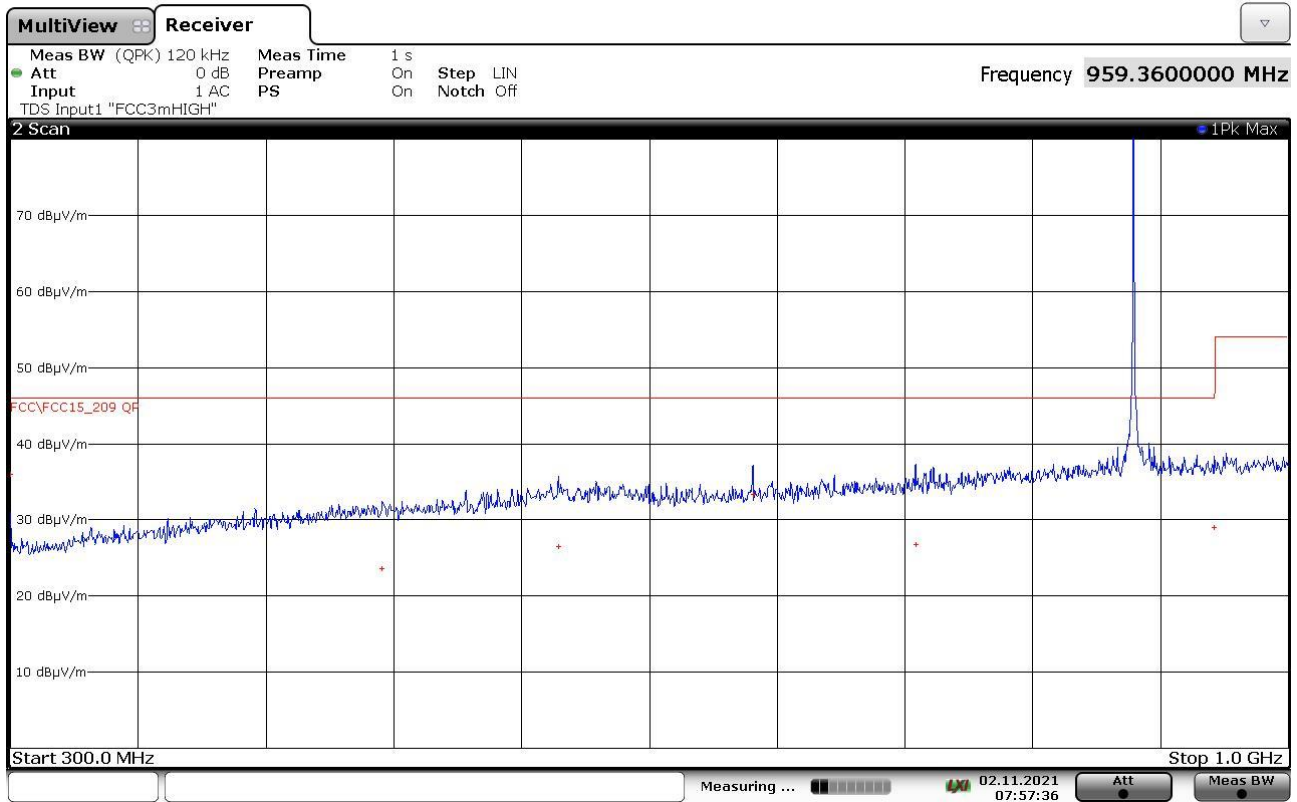

**FINAL RESULT TABLE**

QUASI PEAK		
Freq Hz	Lev dBuV/m	Margin dB
300000000	+36,02	-10,00
503320000	+23,57	-22,45
600080000	+26,47	-19,55
706640000	+33,28	-12,74
795720000	+26,70	-19,32
959360000	+29,03	-16,99

21192710\_2

De Rosso 21192711 vert 3m

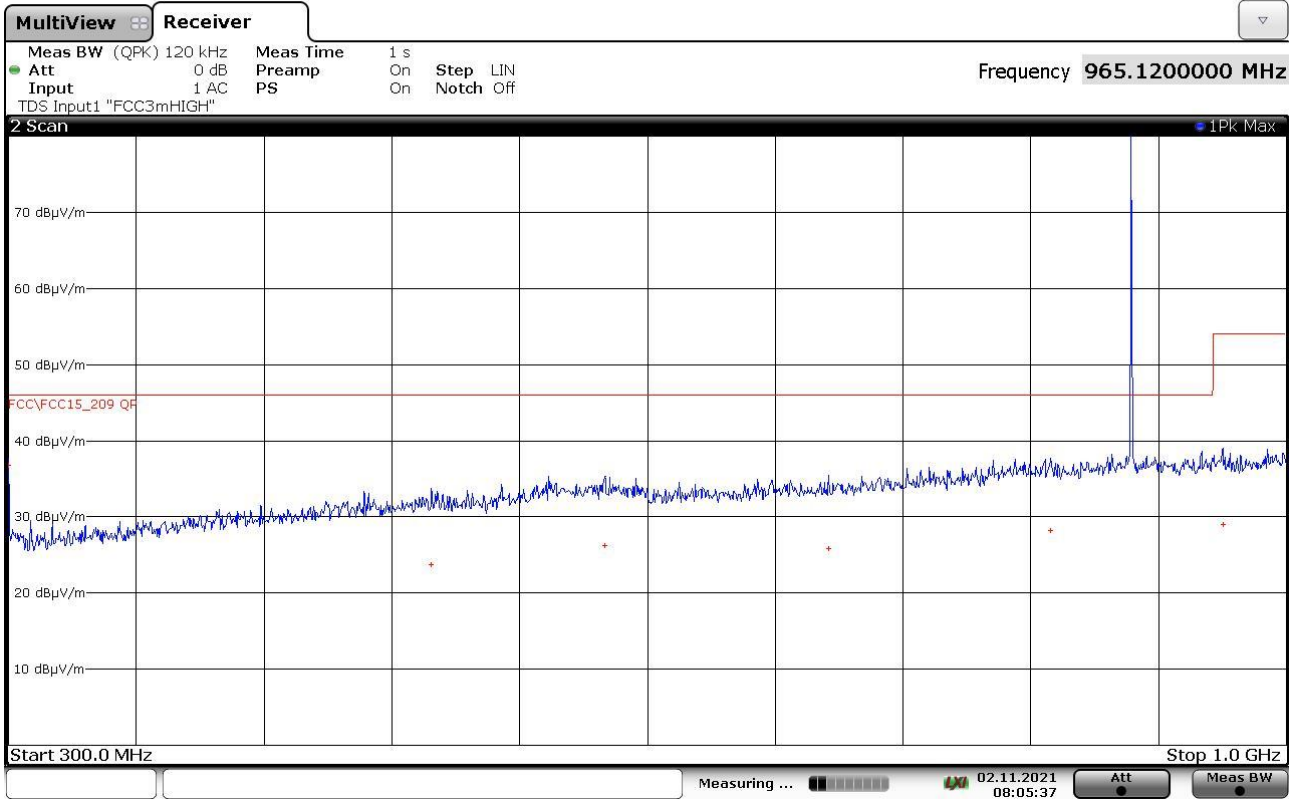

**FINAL RESULT TABLE**

QUASI PEAK		
Freq Hz	Lev dBuV/m	Margin dB
300000000	+36,80	-9,22
531680000	+23,74	-22,28
626880000	+26,17	-19,85
749200000	+25,79	-20,23
870960000	+28,27	-17,75
965120000	+29,00	-24,98

21192711\_2

De Rosso 21192712 horiz 3m

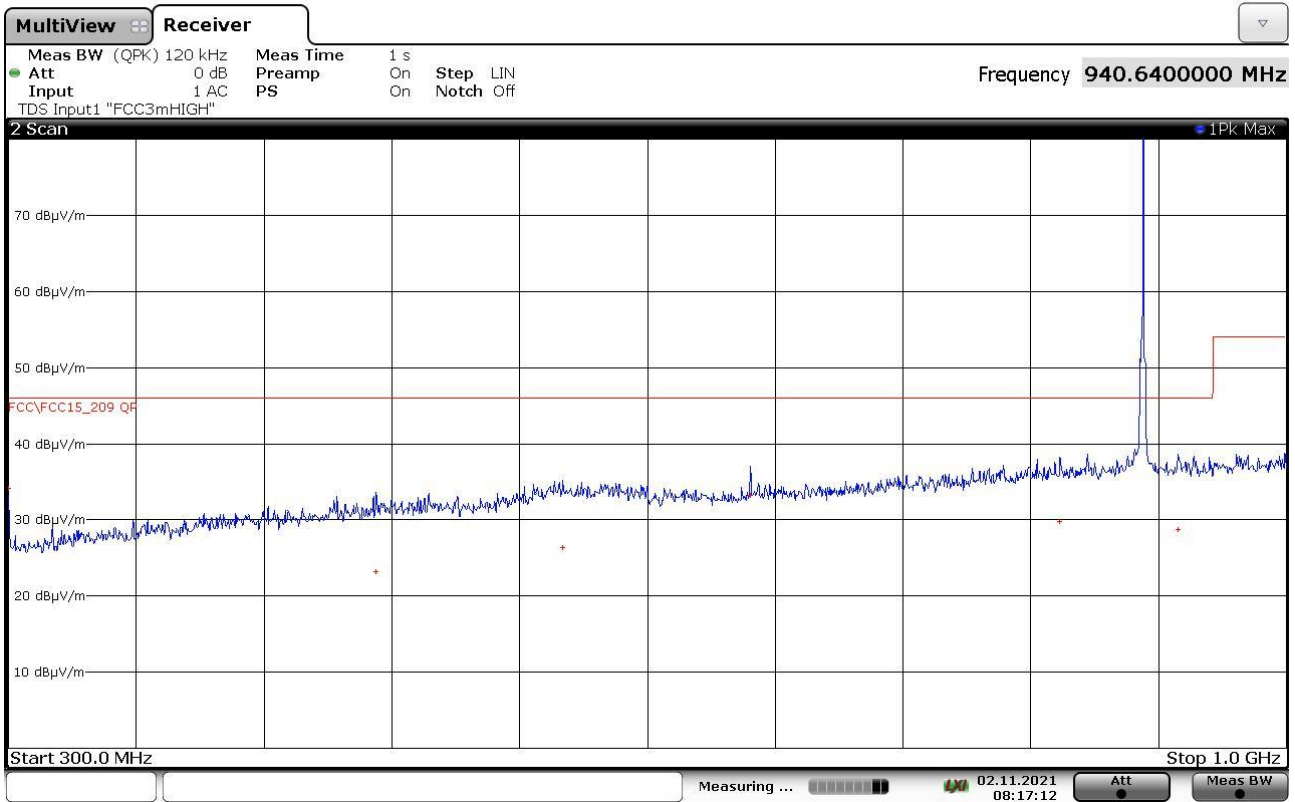

**FINAL RESULT TABLE**

QUASI PEAK		
Freq Hz	Lev dBuV/m	Margin dB
300000000	+34,16	-11,86
501440000	+23,25	-22,77
603640000	+26,31	-19,71
706520000	+33,22	-12,80
876000000	+29,85	-16,17
940640000	+28,78	-17,24

21192712\_2

De Rosso 21192713 vert 3m

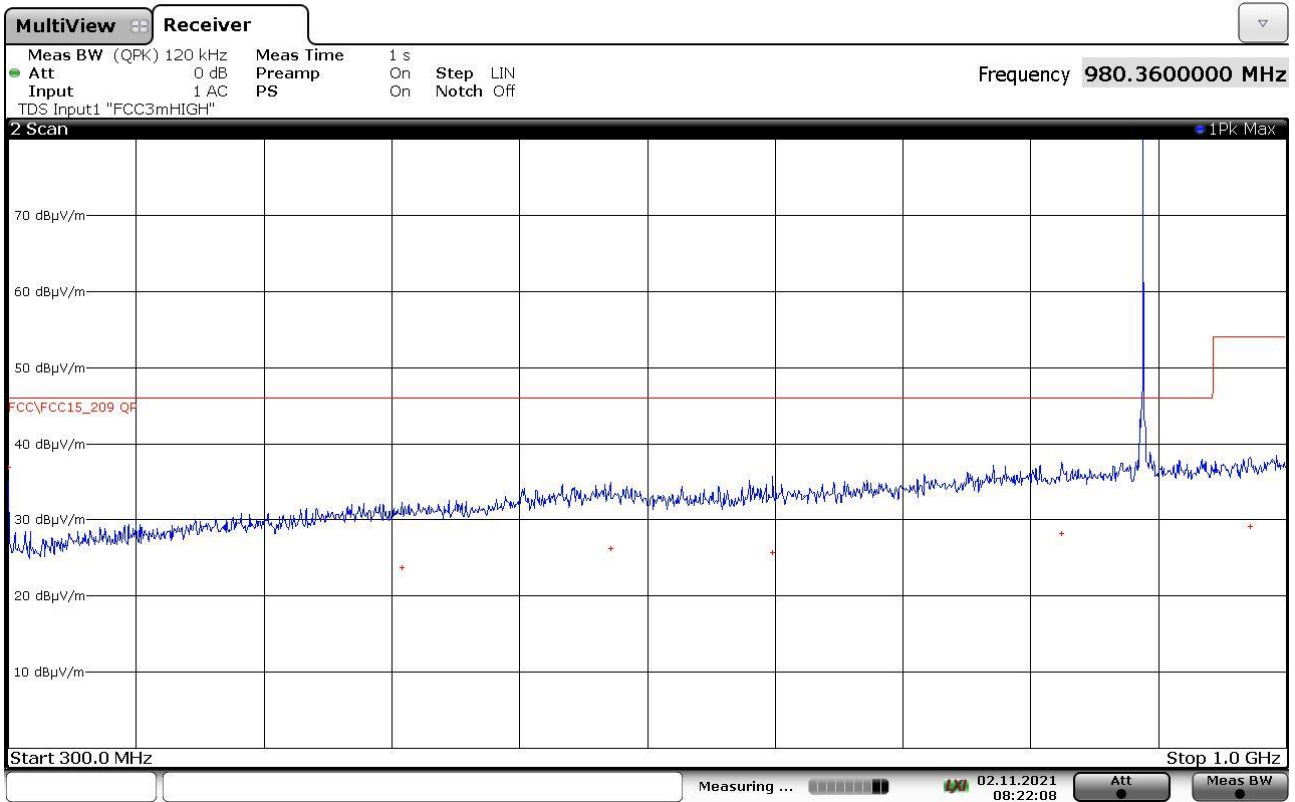

**FINAL RESULT TABLE**

QUASI PEAK		
Freq Hz	Lev dBuV/m	Margin dB
300000000	+36,93	-9,09
515440000	+23,68	-22,34
629760000	+26,26	-19,76
718480000	+25,66	-20,36
877000000	+28,27	-17,75
980360000	+29,07	-24,91

21192713\_2

De Rosso 21192714 horiz 3m

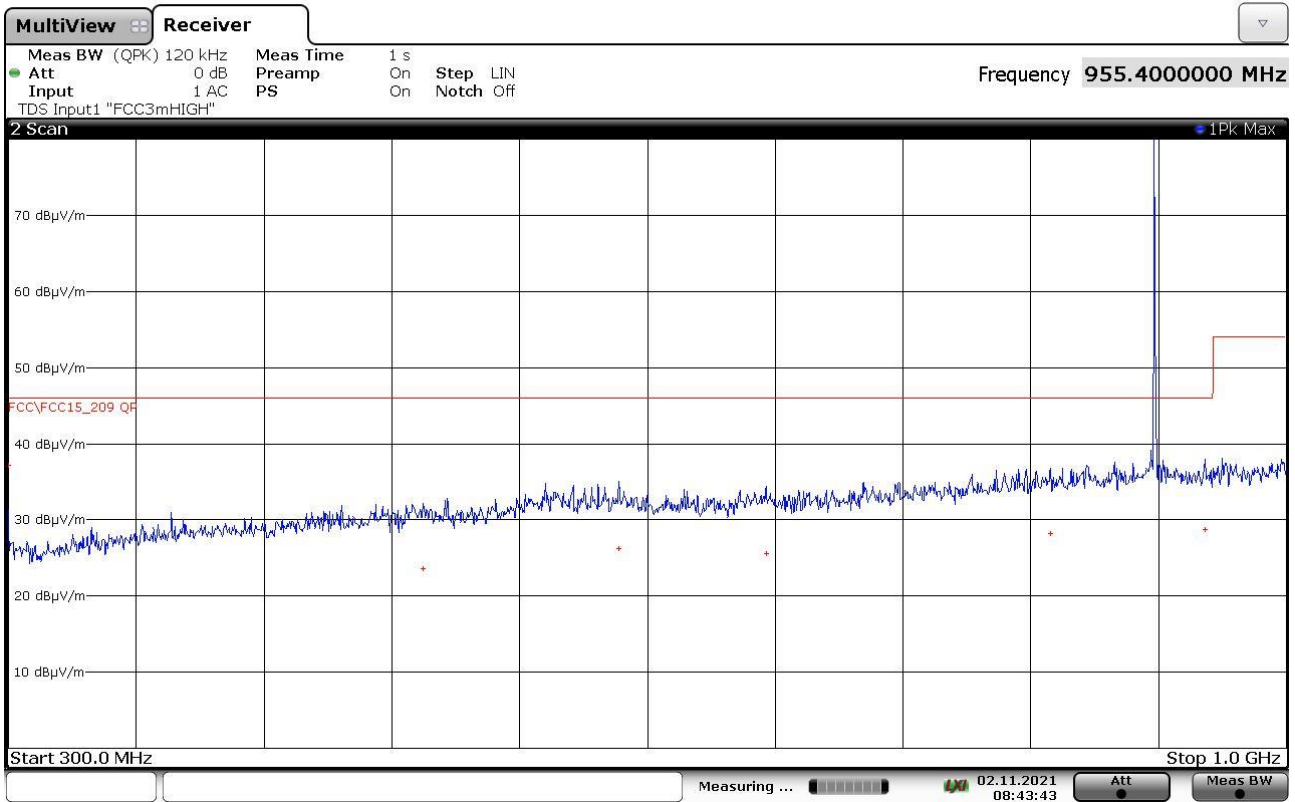

FINAL RESULT TABLE

QUASI PEAK		
Freq Hz	Lev dBuV/m	Margin dB
300000000	+37,20	-8,82
527120000	+23,62	-22,40
634360000	+26,20	-19,82
714920000	+25,55	-20,47
870560000	+28,14	-17,88
955400000	+28,73	-17,29

21192714\_2

De Rosso 21192715 vert 3m

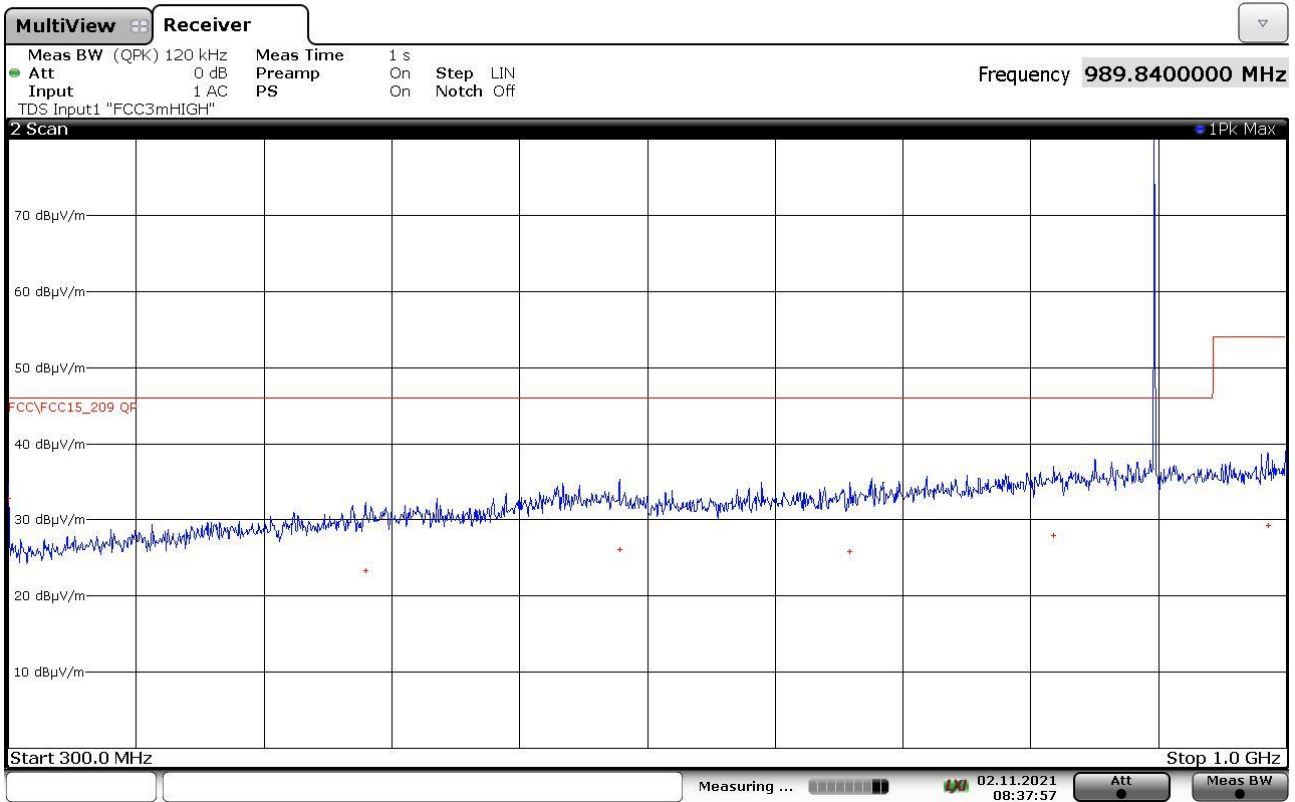

FINAL RESULT TABLE

QUASI PEAK		
Freq Hz	Lev dBuV/m	Margin dB
300000000	+32,87	-13,15
495520000	+23,32	-22,70
634640000	+26,09	-19,93
760960000	+25,79	-20,23
872520000	+27,98	-18,04
989840000	+29,27	-24,71

21192715\_2



### 9.3 20 dB bandwidth

Tested by .....	G. Gandini
Test date .....	08.11.2021
Test location (stand) .....	Laboratory
Reference standards .....	FCC Rules and Regulation; Titles 47 Part. 15.215 (c) ANSI C63.10 cl. 7.8.7
Supplementary test set-up description .....	--
Supplementary information.....	--

### Test setup

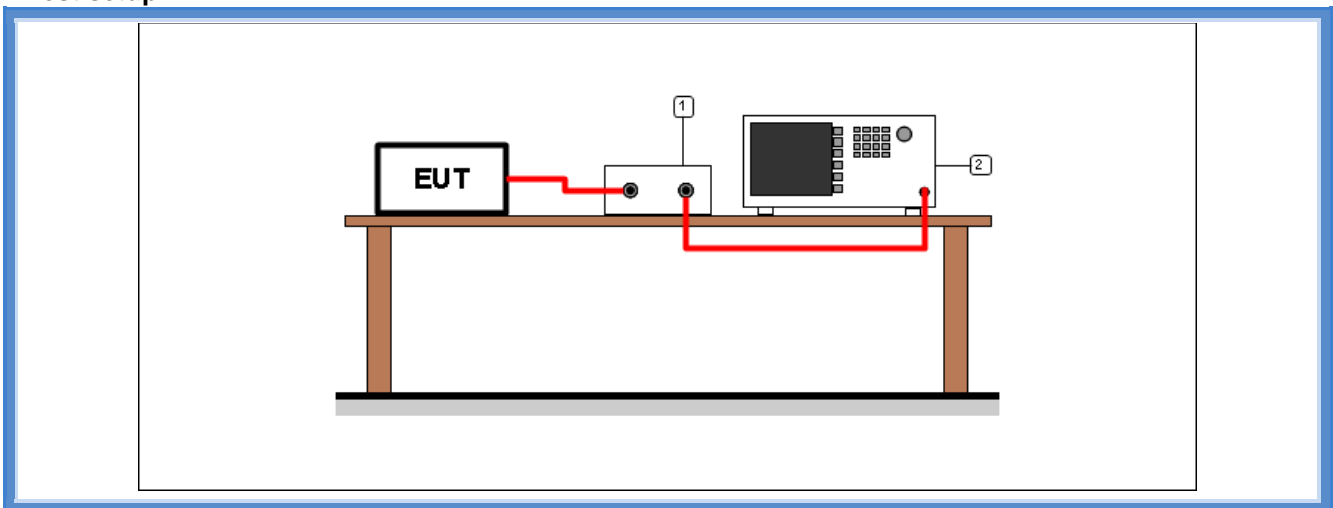

Test setup PR002\_01

Nr.	Id. Number	Manufacturer	Model	Description
2	CMC S295	Rohde & Schwarz	FSW43	Spectrum Analyzer 43GHz
1	--	--	--	Cable + attenuator (calibrated before the test)

### Result

Frequency (MHz)	Graphs	20 dB bandwidth (kHz)
915,075	G21192725	23,58
921,425	G21192721	23,68
927,825	G21192716	23,68



## Graphs

Gandini 21192716

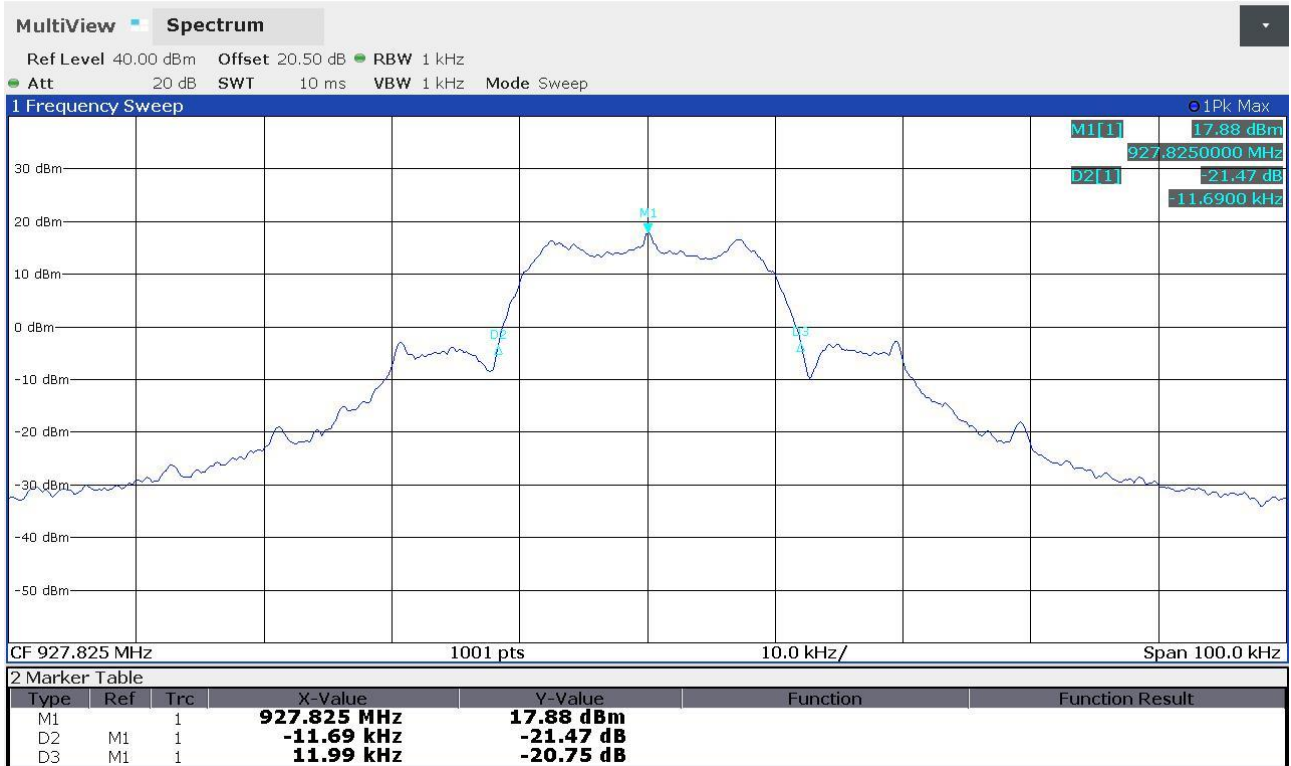

Gandini 21192721

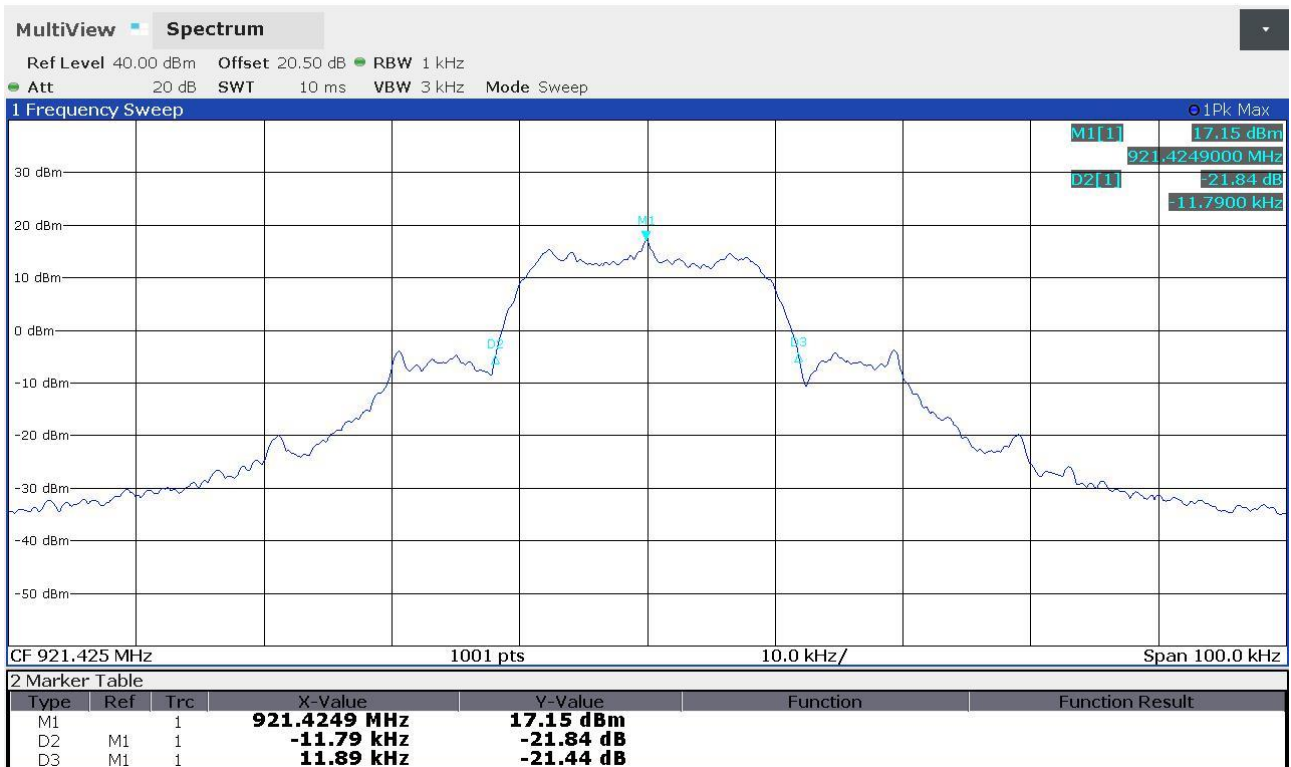

Gandini 21192725

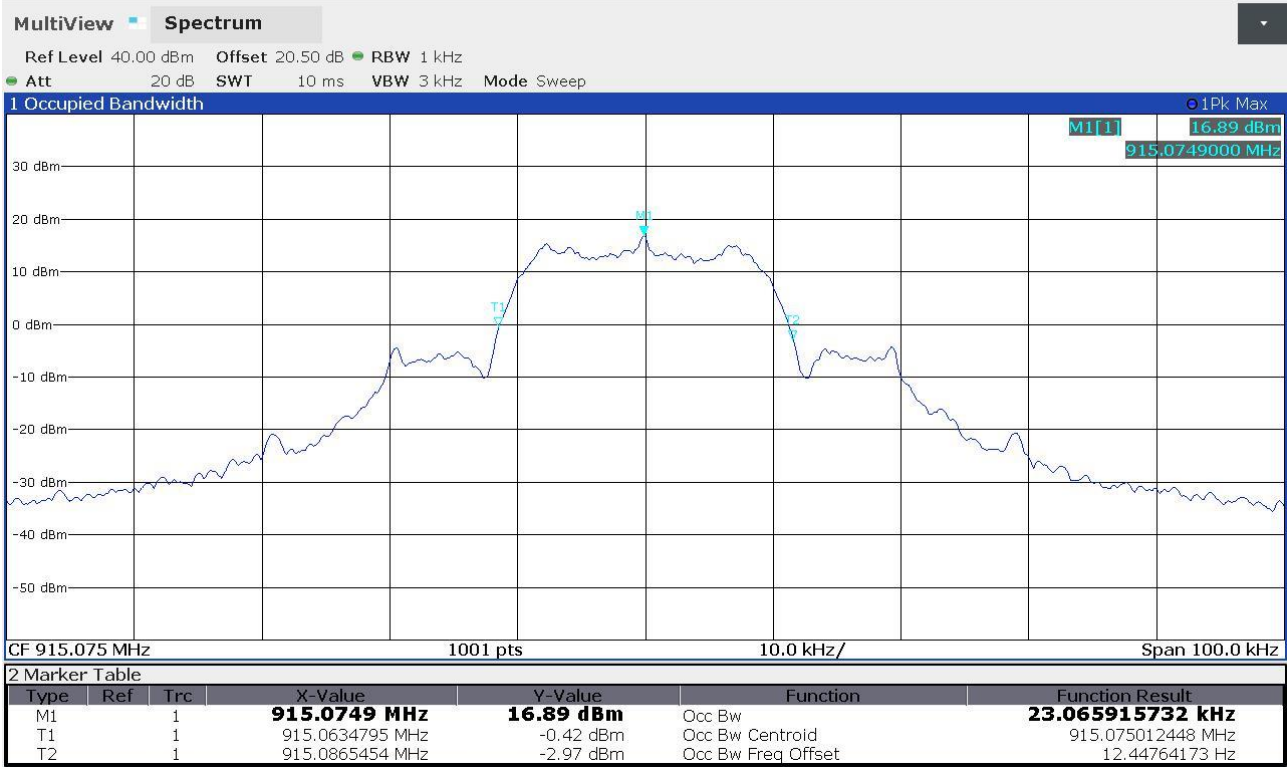

#### 9.4 Channel separation

Tested by .....	G. Gandini
Test date .....	08.11.2021
Test location (stand) .....	Laboratory
Reference standards .....	FCC Rules and Regulation; Titles 47 Part. 15.247 KDB 558074 D01 15.247 Meas Guidance v05r02 cl. 9 b) ANSI C63.10 cl. 7.8.2
Supplementary test set-up description .....	--
Supplementary information.....	--

#### Acceptance limits

Frequency hopping systems shall have hopping channel carrier frequencies separated by a minimum of 25 kHz or the 20 dB bandwidth of the hopping channel, whichever is greater. Alternatively, frequency hopping systems operating in the 2400–2483.5 MHz band may have hopping channel carrier frequencies that are separated by 25 kHz or two-thirds of the 20 dB bandwidth of the hopping channel, whichever is greater, provided the systems operate with an output power no greater than 125 mW. The system shall hop to channel frequencies that are selected at the system hopping rate from a pseudo randomly ordered list of hopping frequencies. Each frequency must be used equally on the average by each transmitter. The system receivers shall have input bandwidths that match the hopping channel bandwidths of their corresponding transmitters and shall shift frequencies in synchronization with the transmitted signals.

#### Test setup

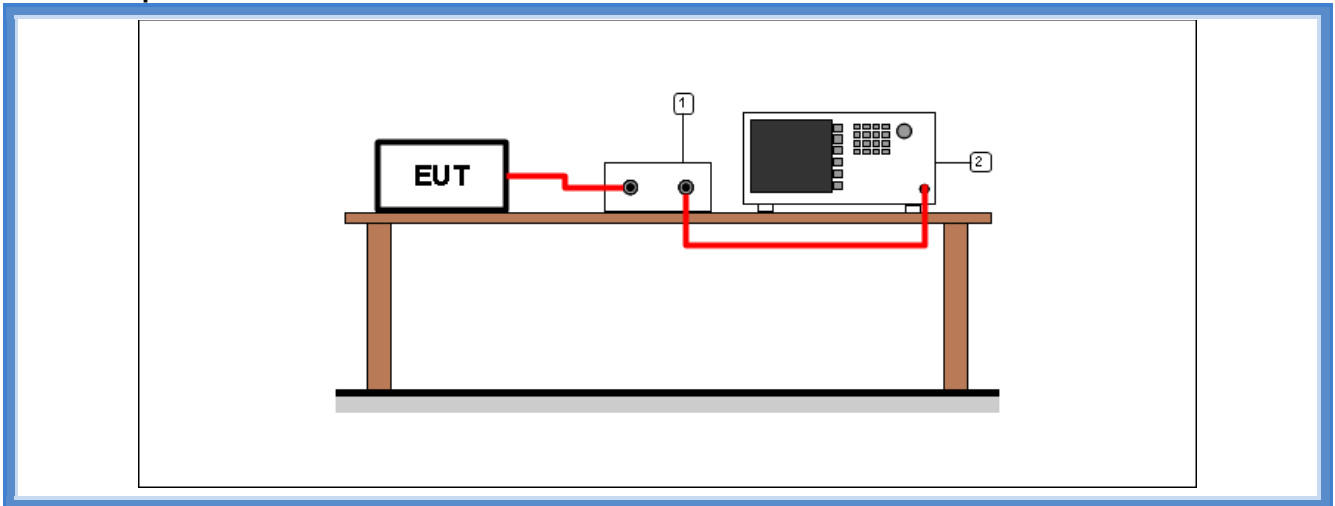

Test setup PR002\_01

Nr.	Id. Number	Manufacturer	Model	Description
2	CMC S295	Rohde & Schwarz	FSW43	Spectrum Analyzer 43GHz
1	--	--	--	Cable + attenuator (calibrated before the test)

**Result**

<i>Frequency band (MHz)</i>	<i>Graphs</i>	<i>Channel separation (kHz)</i>	<i>Minimum channel separation required (kHz)</i>	<i>Results</i>
902 – 928	G21192736	200,2	25	Complies

## Graphs

Gandini 21192736

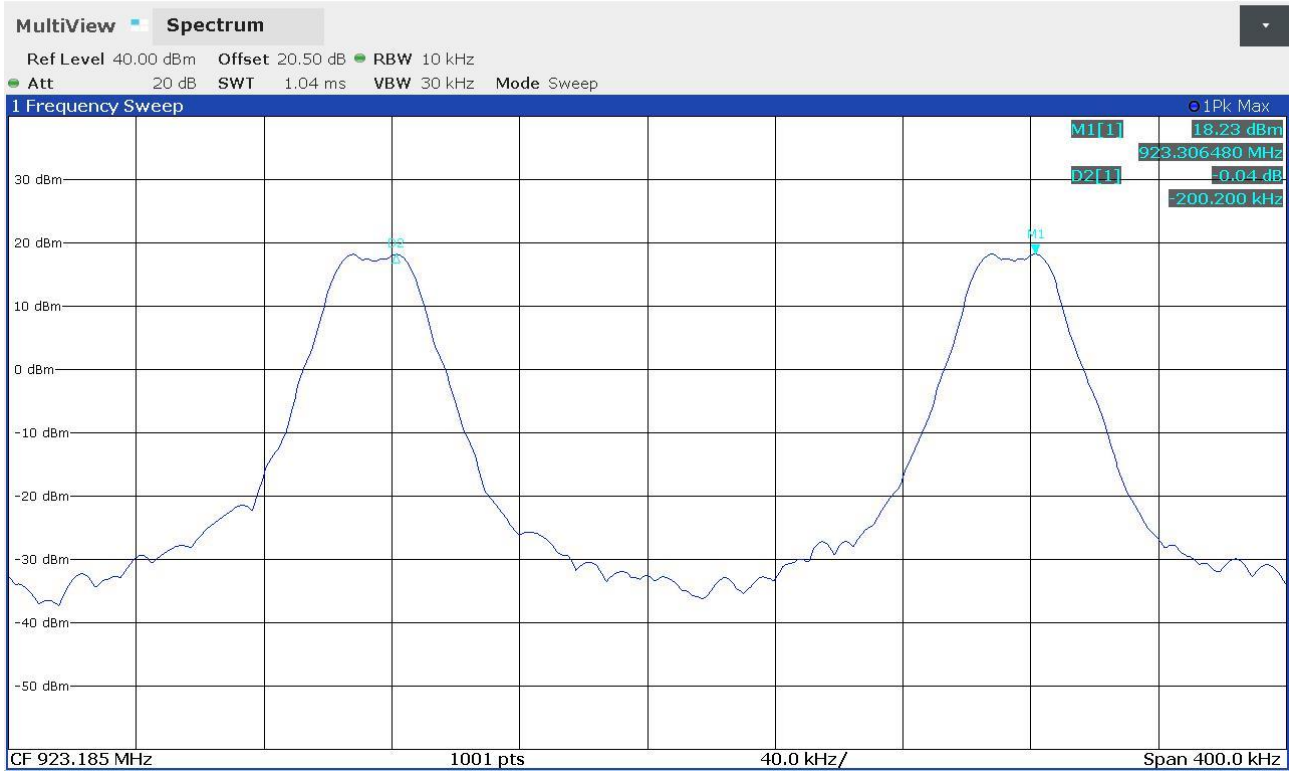

## 9.5 Number of hopping channels

Tested by .....	G. Gandini
Test date .....	08.11.2021
Test location (stand) .....	Laboratory
Reference standards .....	FCC Rules and Regulation; Titles 47 Part. 15.247 KDB 558074 D01 15.247 Meas Guidance v05r02 cl. 9 b) ANSI C63.10 cl. 7.8.3
Supplementary test set-up description .....	--
Supplementary information.....	--

### Acceptance limits

For frequency hopping systems operating in the 902 – 928 MHz band: if the 20 dB bandwidth of the hopping channel is less than 250 kHz, the system shall use at least 50 hopping frequencies and the average time of occupancy on any frequency shall not be greater than 0,4 seconds within a 20 second period; if the 20 dB bandwidth of the hopping channel is 250 kHz or greater, the system shall use at least 25 hopping frequencies and the average time of occupancy on any frequency shall not be greater than 0,4 seconds within a 10 second period. The maximum allowed 20 dB bandwidth of the hopping channel is 500 kHz.

### Test setup

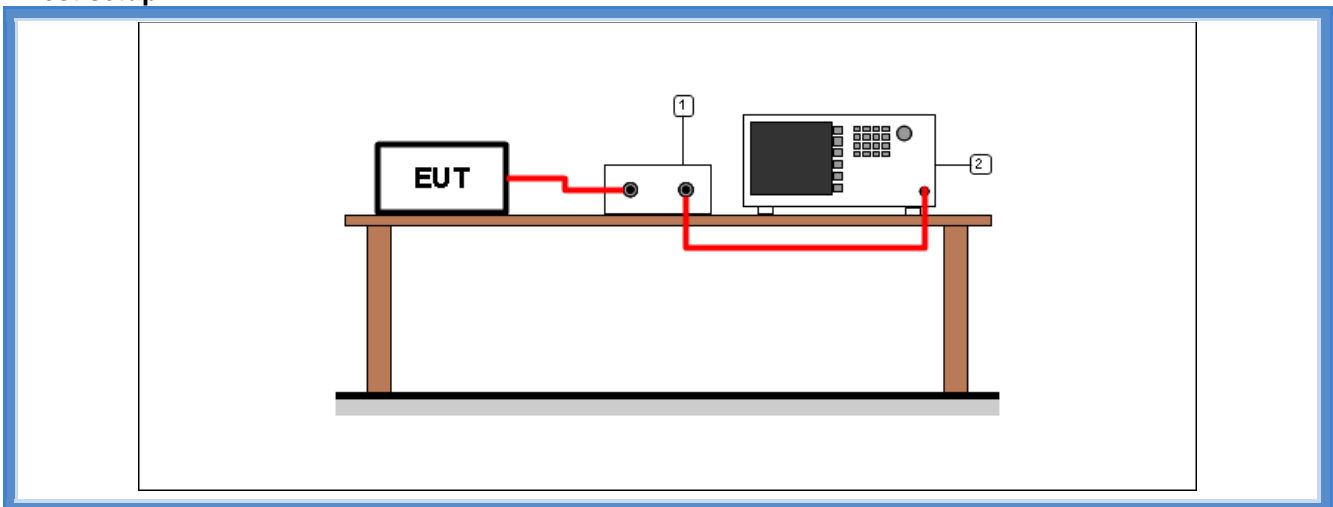

Test setup PR002\_01

Nr.	Id. Number	Manufacturer	Model	Description
2	CMC S295	Rohde & Schwarz	FSW43	Spectrum Analyzer 43GHz
1	--	--	--	Cable + attenuator (calibrated before the test)

**Result**

<i>Frequency band (MHz)</i>	<i>Graphs</i>	<i>Number of hopping channels</i>	<i>Minimum number of hopping channels required</i>	<i>Results</i>
902 – 928	G21192733 G21192734 G21192735	64	50	Complies



## Graphs

Gandini 21192733

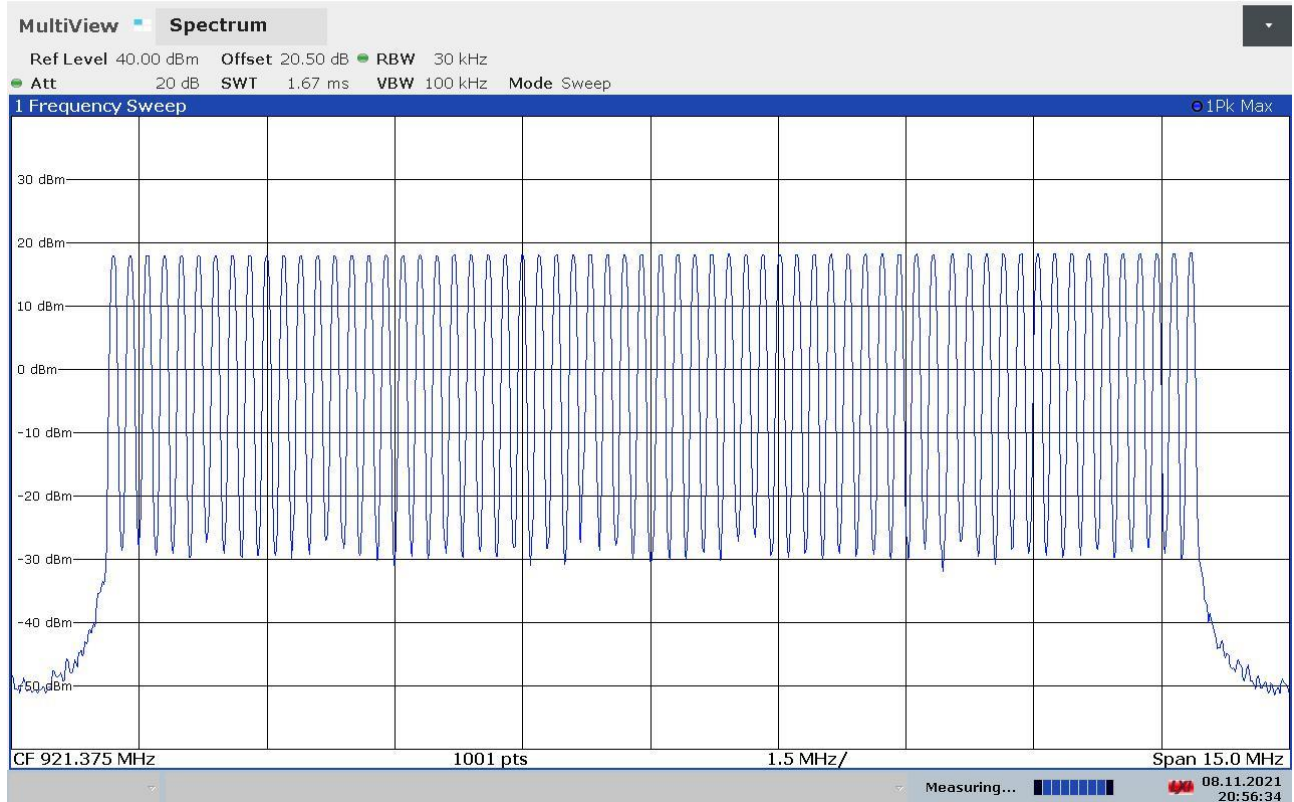

Gandini 21192734

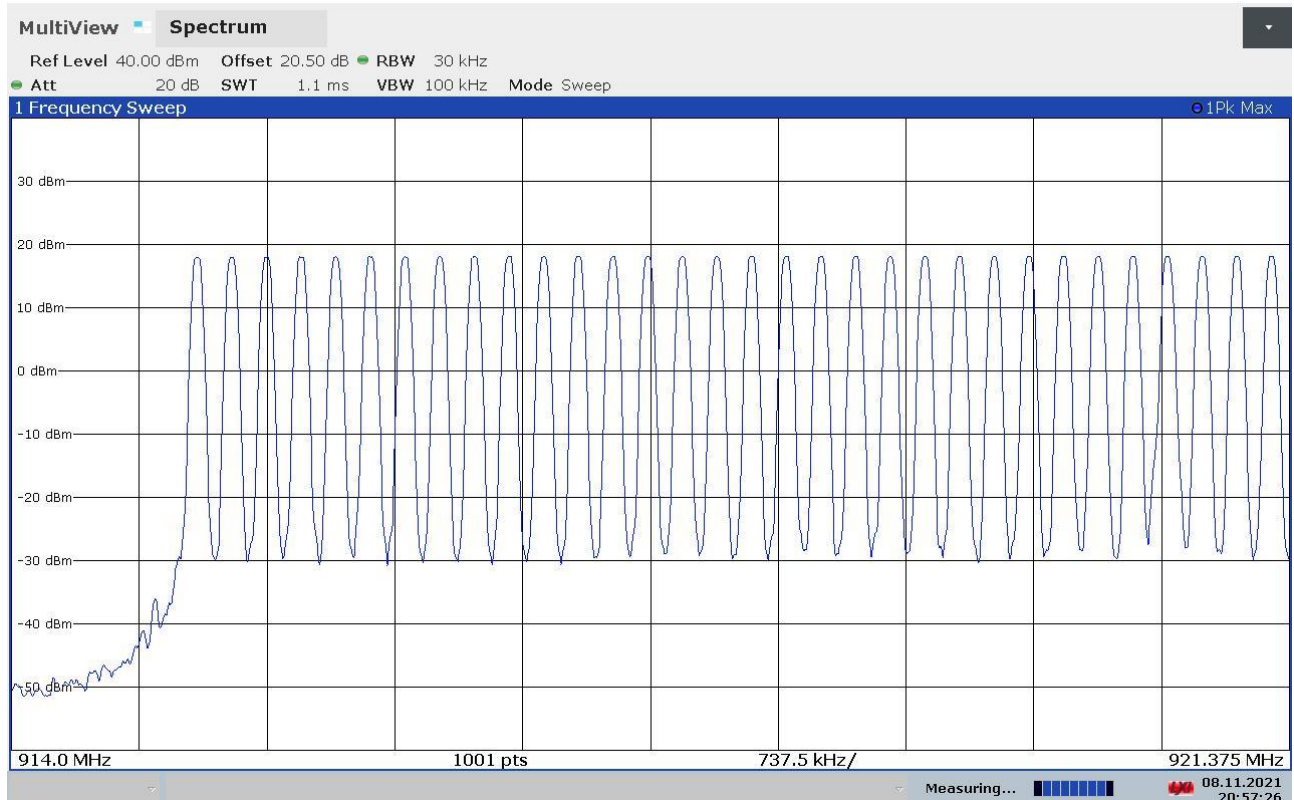

Gandini 21192735

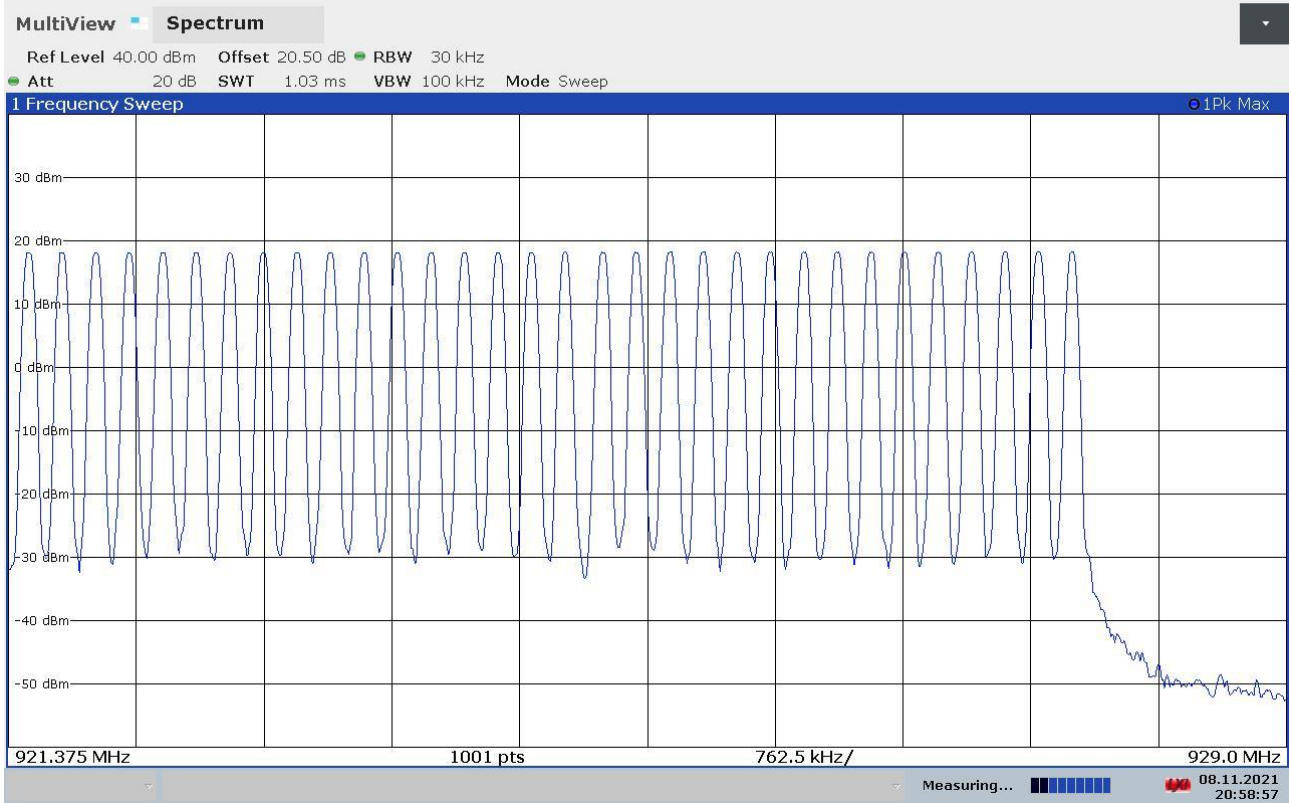

## 9.6 Time of occupancy

Tested by .....	G. Gandini
Test date .....	08.11.2021
Test location (stand) .....	Laboratory
Reference standards .....	FCC Rules and Regulation; Titles 47 Part. 15.247 KDB 558074 D01 15.247 Meas Guidance v05r02 cl. 9 b) ANSI C63.10 cl. 7.8.4
Supplementary test set-up description .....	--
Supplementary information.....	--

### Acceptance limits

For frequency hopping systems operating in the 902 – 928 MHz band: if the 20 dB bandwidth of the hopping channel is less than 250 kHz, the system shall use at least 50 hopping frequencies and the average time of occupancy on any frequency shall not be greater than 0,4 seconds within a 20 second period; if the 20 dB bandwidth of the hopping channel is 250 kHz or greater, the system shall use at least 25 hopping frequencies and the average time of occupancy on any frequency shall not be greater than 0,4 seconds within a 10 second period. The maximum allowed 20 dB bandwidth of the hopping channel is 500 kHz.

### Test setup

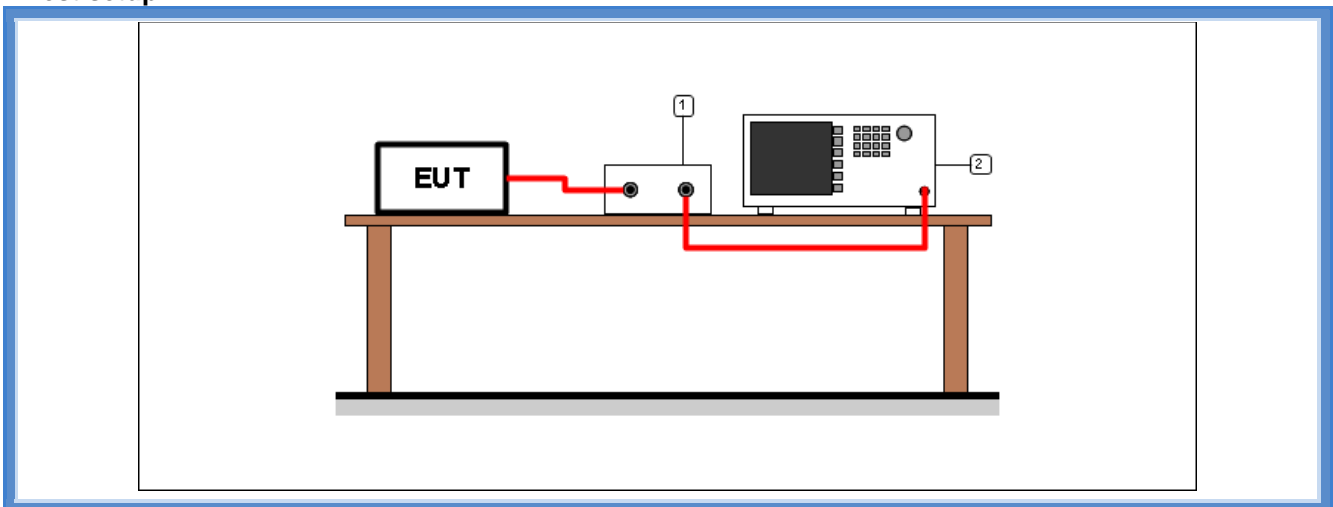

Test setup PR002\_01

Nr.	Id. Number	Manufacturer	Model	Description
2	CMC S295	Rohde & Schwarz	FSW43	Spectrum Analyzer 43GHz
1	--	--	--	Cable + attenuator (calibrated before the test)

**Result**

<i>Frequency (MHz)</i>	<i>Graphs</i>	<i>Dwell time (ms)</i>
923,10	G21192737	20,85

<i>Frequency (MHz)</i>	<i>Graphs</i>	<i>Number of transmissions</i>	<i>Period</i>
923,10	G21192738	8	20 s

**Remarks:** only the highest peaks have been considered. The lowest peaks are due to the auxiliary receiver unit

<i>Time of occupancy (Dwell time x Nr. transmissions)</i>	<i>Maximum allowed time of occupancy</i>	<i>Results</i>
166,80 ms	400 ms	Complies

## Graphs

Gandini 21192737

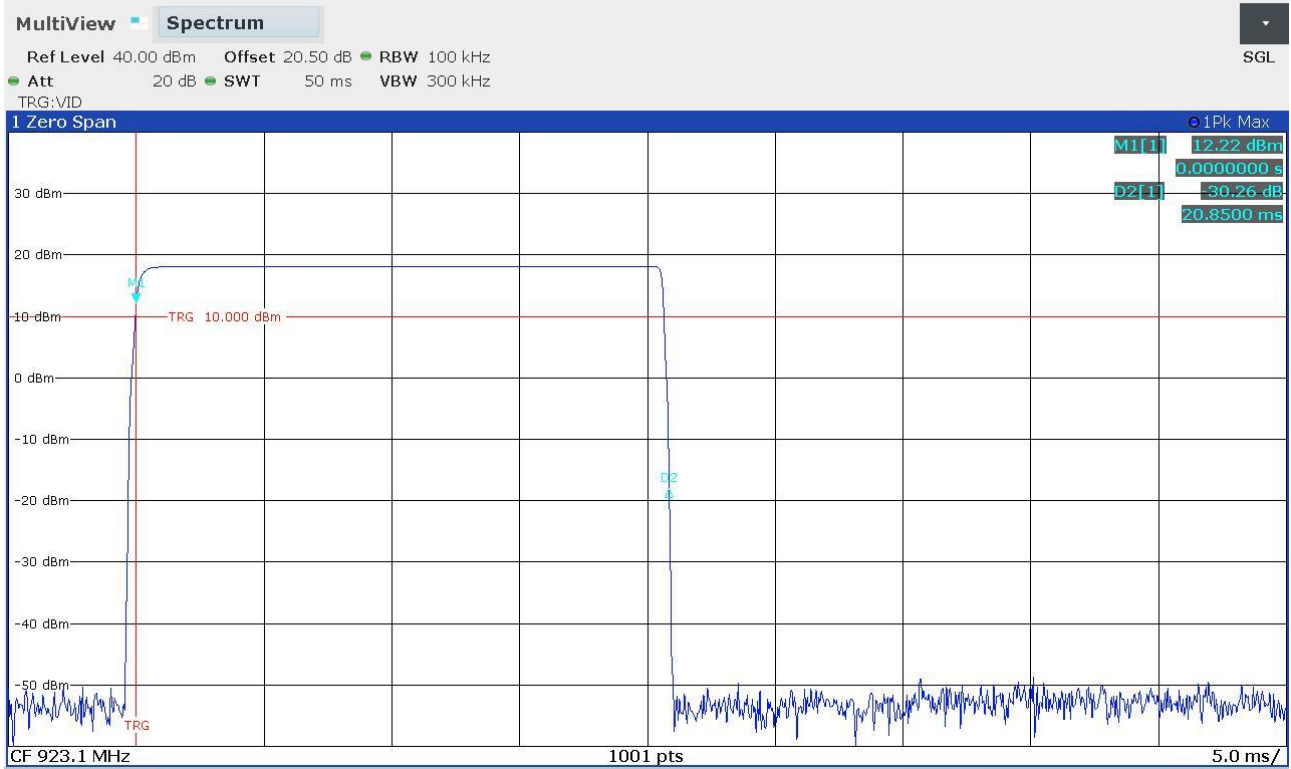

Gandini 21192738

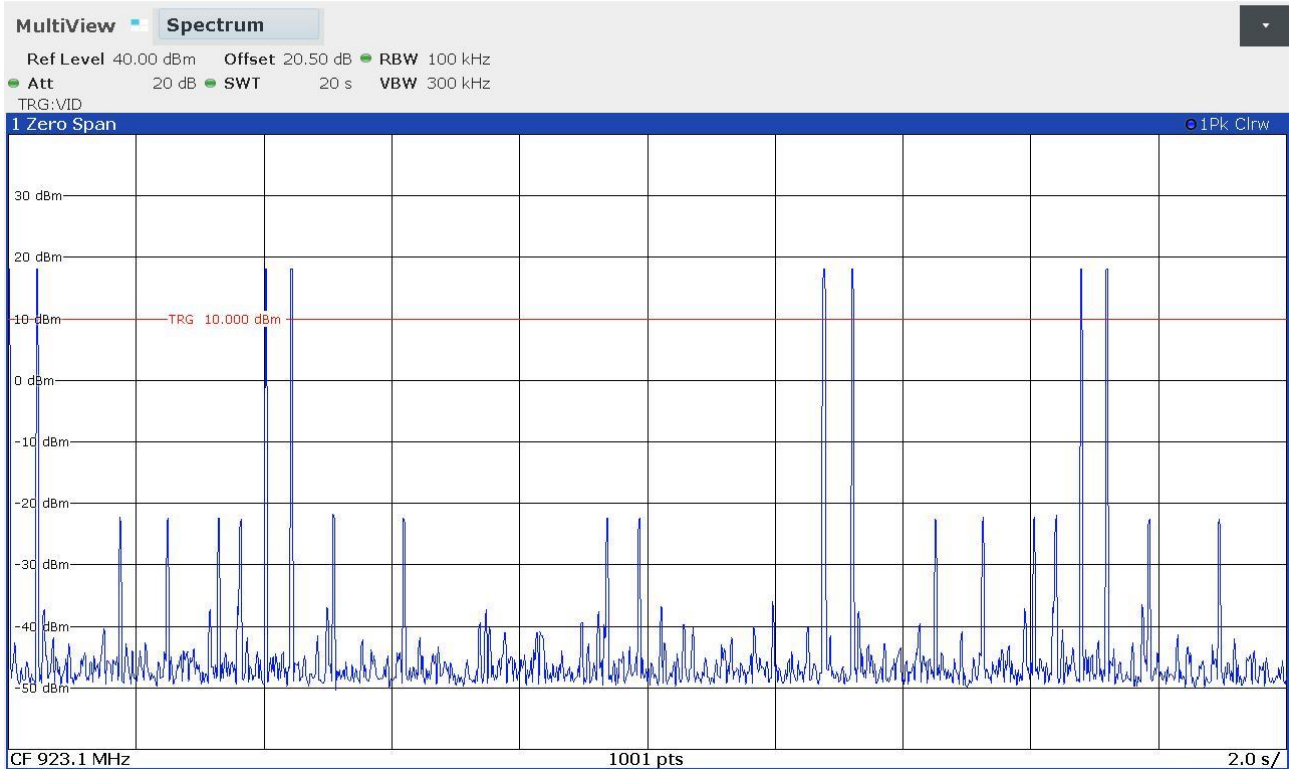

## 9.7 Band edge

Tested by .....	G. Gandini
Test date .....	08.11.2021
Test location (stand) .....	Laboratory
Reference standards .....	FCC Rules and Regulation; Titles 47 Part. 15.247 ANSI C63.10 cl. 7.8.6
Supplementary test set-up description .....	--
Supplementary information.....	--

### Acceptance limits

In any 100 kHz bandwidth outside the frequency band in which the spread spectrum or digitally modulated intentional radiator is operating, the radio frequency power that is produced by the intentional radiator shall be at least 20 dB below that in the 100 kHz bandwidth within the band that contains the highest level of the desired power, based on either an RF conducted or a radiated measurement, provided the transmitter demonstrates compliance with the peak conducted power limits. If the transmitter complies with the conducted power limits based on the use of RMS averaging over a time interval, as permitted under paragraph (b)(3) of this section, the attenuation required under this paragraph shall be 30 dB instead of 20 dB. Attenuation below the general limits specified in § 15.209(a) is not required. In addition, radiated emissions which fall in the restricted bands, as defined in §15.205(a), must also comply with the radiated emission limits specified in § 15.209(a) (see § 15.205(c)).

Operation within the band 902 – 928 MHz.

### Test setup

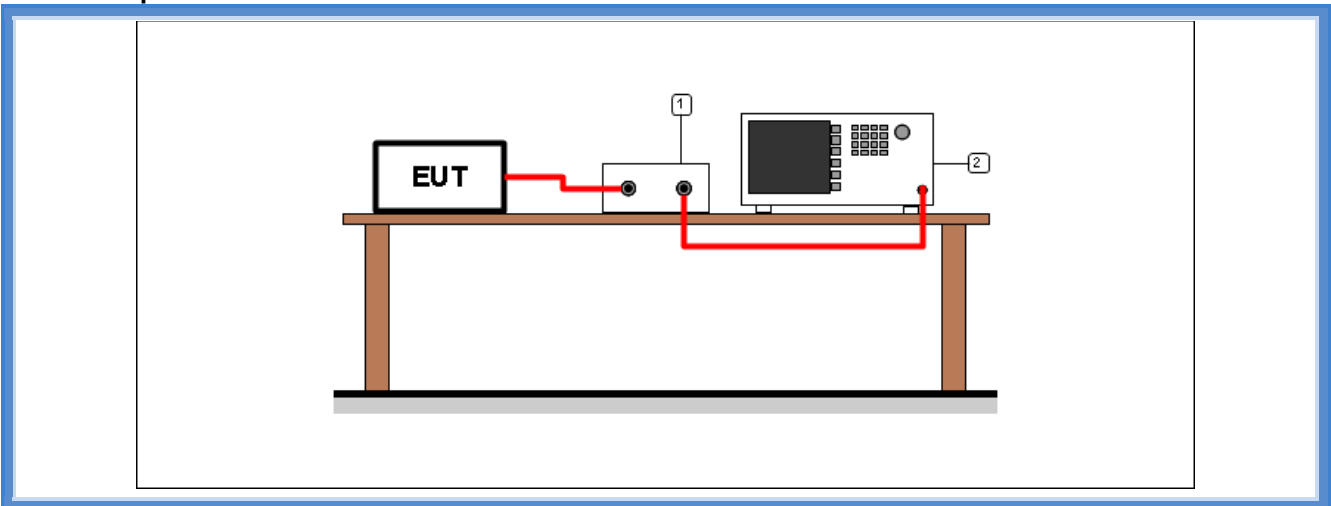

Test setup PR002_01				
Nr.	Id. Number	Manufacturer	Model	Description
2	CMC S295	Rohde & Schwarz	FSW43	Spectrum Analyzer 43GHz
1	--	--	--	Cable + attenuator (calibrated before the test)

**Result**

<i>Frequency (MHz)</i>	<i>Bandwidth</i>	<i>Graph(s) – Hopping</i>	<i>Results</i>	
915,075	100 kHz	G21192730 G21192729	F <sub>L</sub> : 914,9320 MHz	Complies
927,825	100 kHz	G21192731 G21192732	F <sub>H</sub> : 927,9651 MHz	Complies

<i>Frequency (MHz)</i>	<i>Bandwidth</i>	<i>Graph(s) – No hopping</i>	<i>Results</i>	
915,075	100 kHz	G21192727 G21192728	F <sub>L</sub> : 914,9340 MHz	Complies
927,825	100 kHz	G21192719 G21192720	F <sub>H</sub> : 927,9671 MHz	Complies



## Graphs

Gandini 21192719

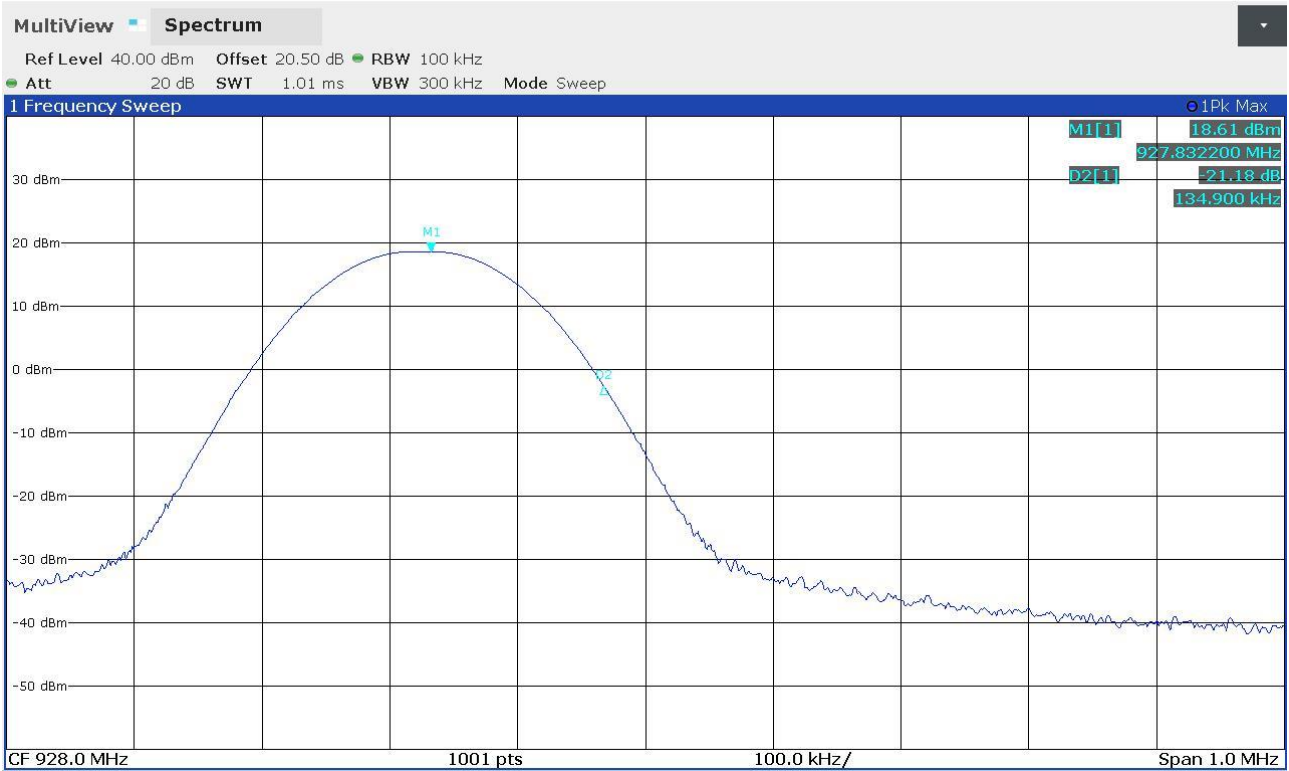

Gandini 21192720

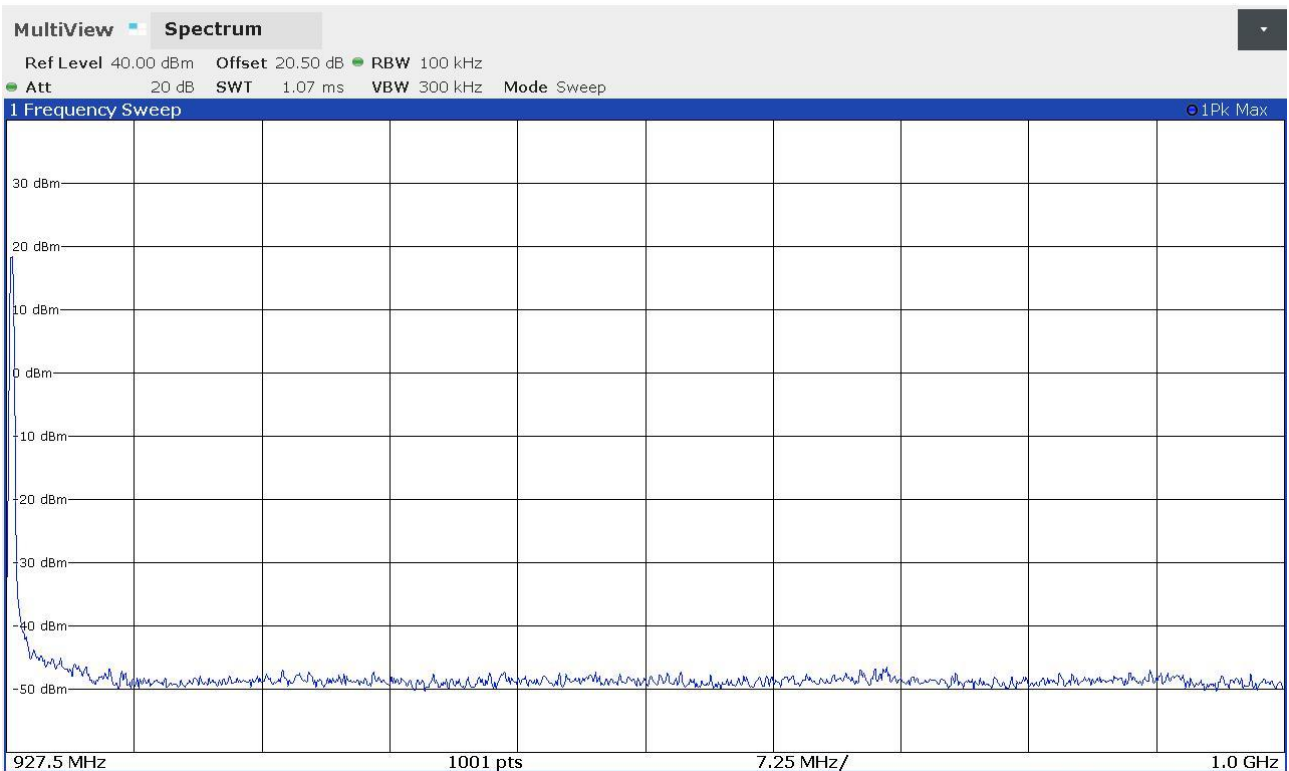

Gandini 21192727

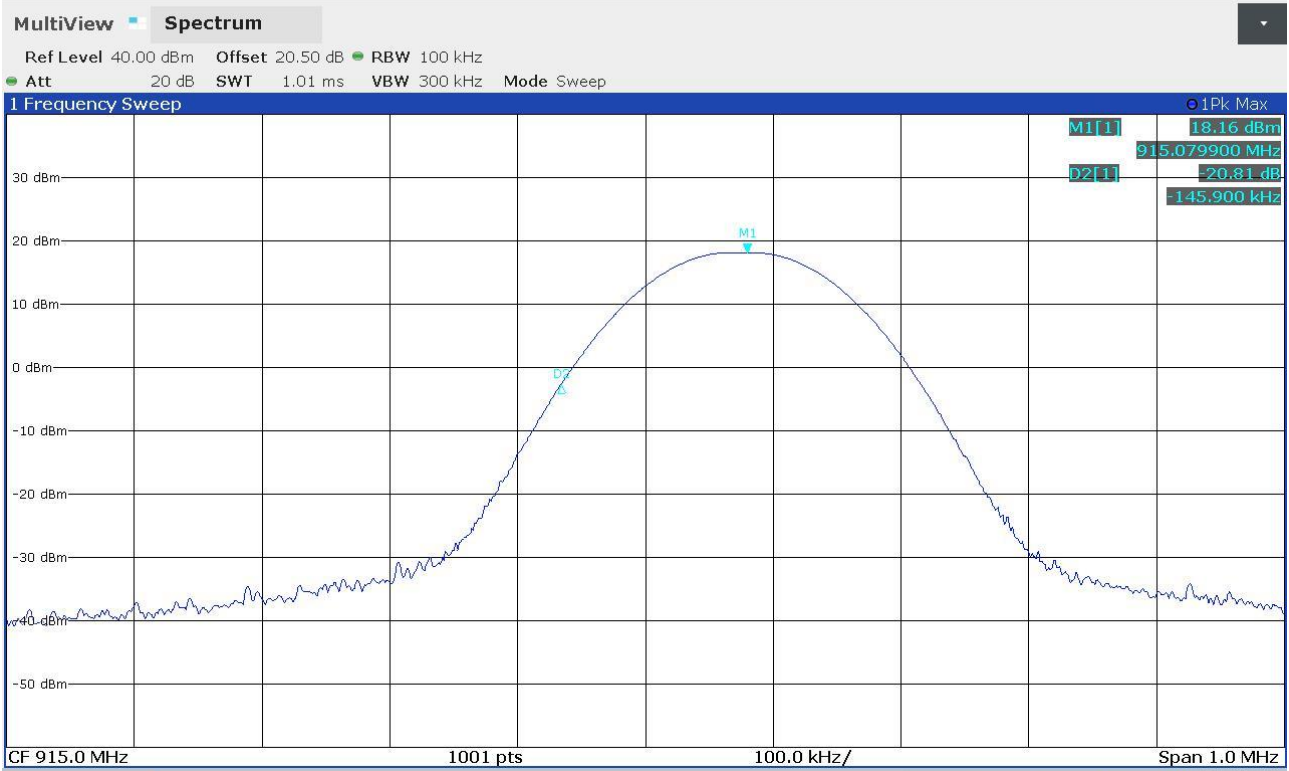

Gandini 21192728

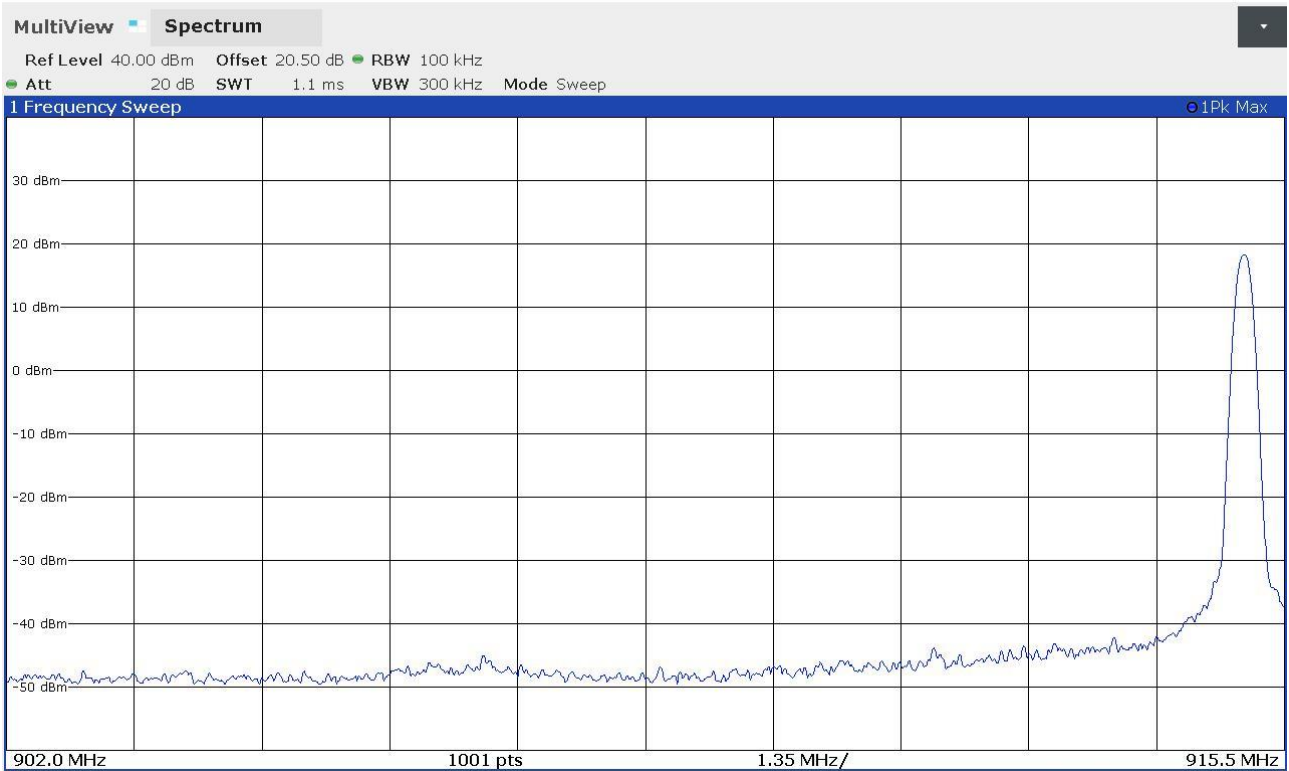

Gandini 21192729

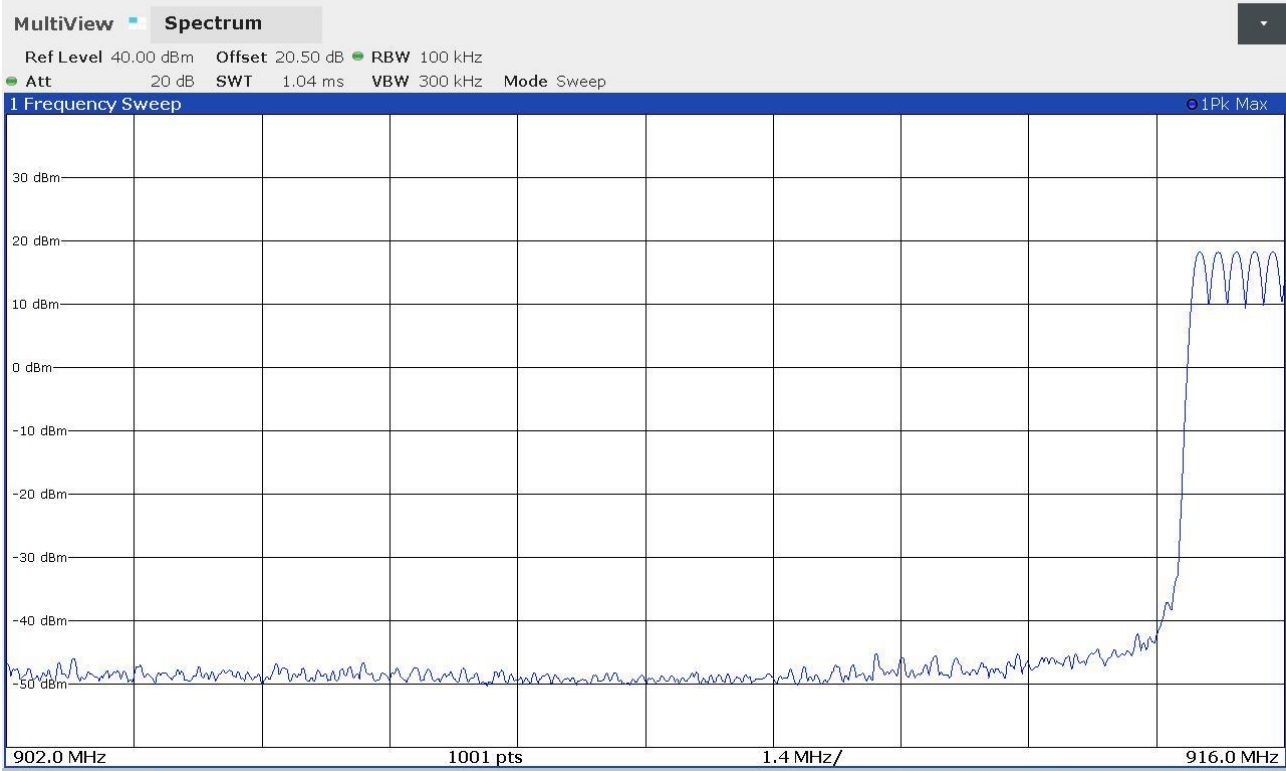

Gandini 21192730

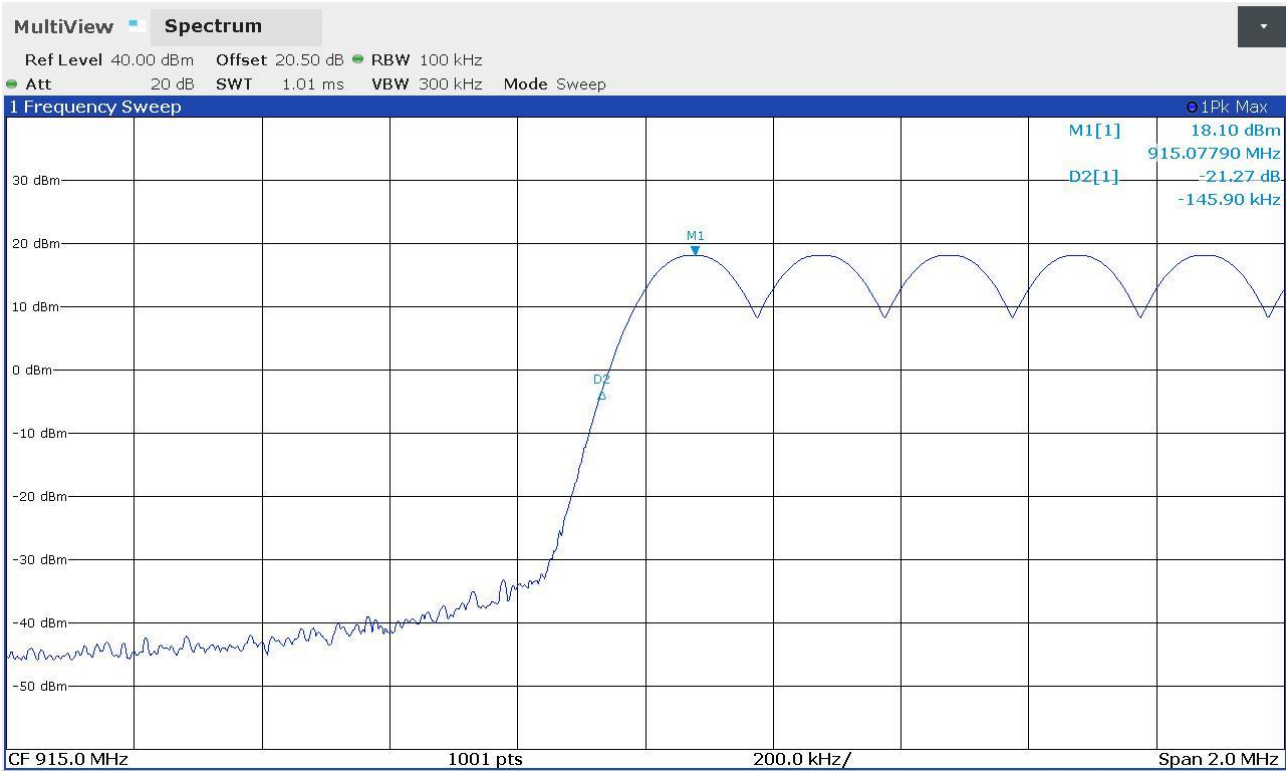

**Gandini 21192731**

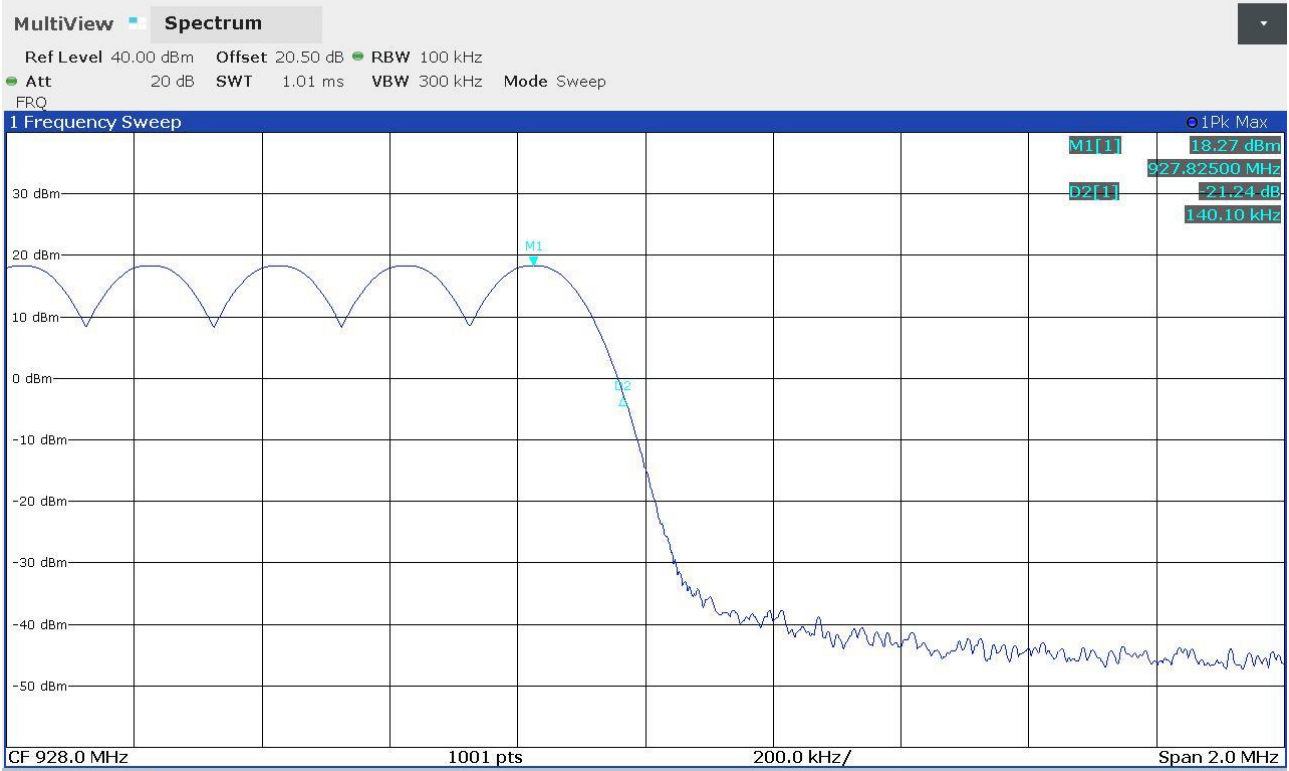

**Gandini 21192732**

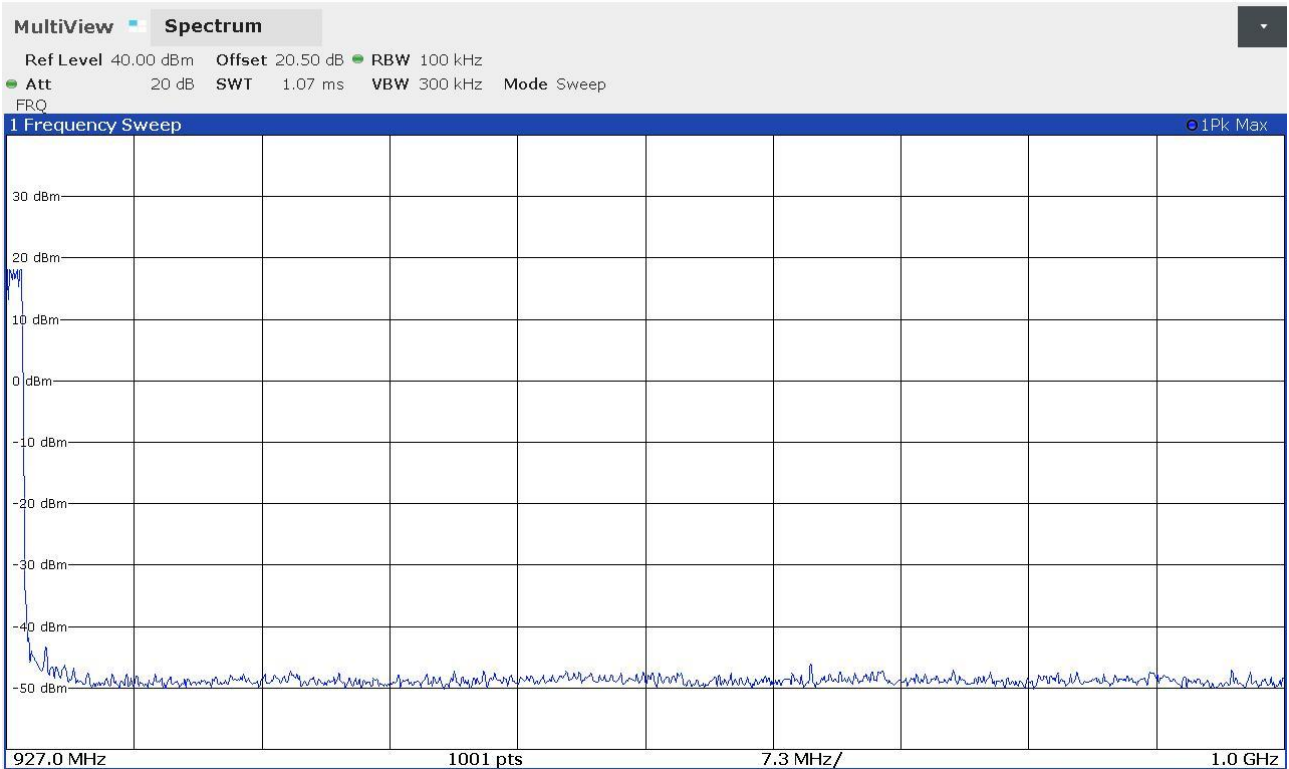

## 9.8 Peak Output Power

Tested by .....	G. Gandini
Test date .....	08.11.2021
Test location (stand) .....	Laboratory
Reference standards .....	FCC Rules and Regulation; Titles 47 Part. 15.247 KDB 558074 D01 15.247 Meas Guidance v05r02 cl. 2.2 ANSI C63.10 cl. 7.8.5
Supplementary test set-up description .....	--
Supplementary information.....	--

### Acceptance limits

For frequency hopping systems operating in the 902–928 MHz band: 1 watt for systems employing at least 50 hopping channels; and, 0,25 watts for systems employing less than 50 hopping channels, but at least 25 hopping channels.

### Test setup

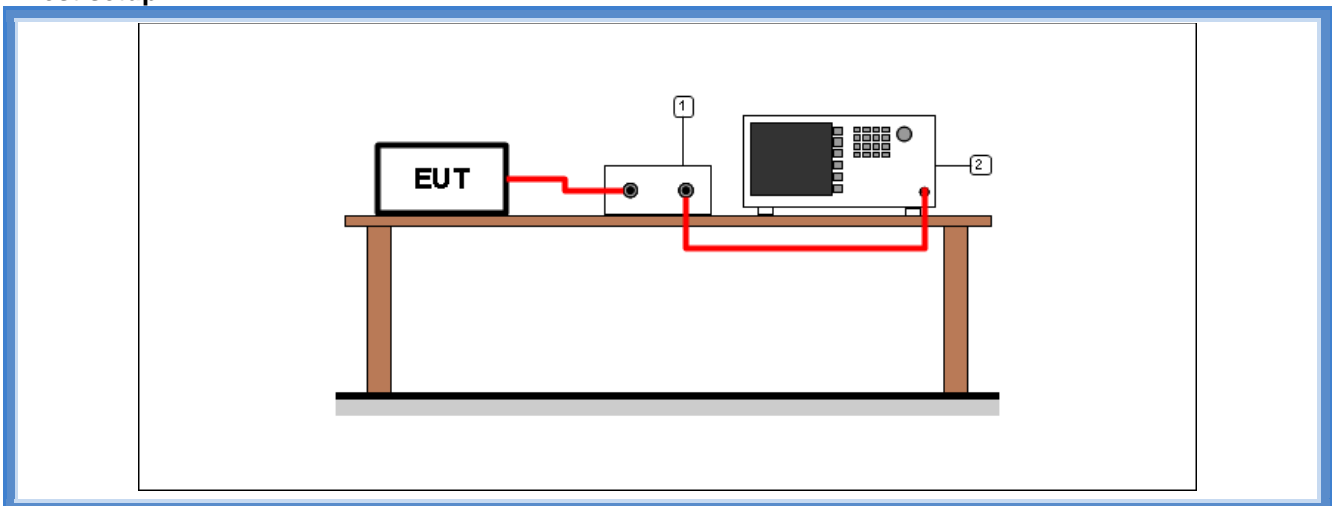

Test setup PR002\_01

Nr.	Id. Number	Manufacturer	Model	Description
2	CMC S295	Rohde & Schwarz	FSW43	Spectrum Analyzer 43 GHz
1	--	--	--	Cable + attenuator (calibrated before the test)

### Result

Frequency (MHz)	Graphs	Peak Output Power (dBm)	Peak Output Power (mW)	Limit (mW)
915,075	G21192724	18,22	66,37	1000
921,425	G21192723	18,35	68,39	1000
927,825	G21192718	18,56	71,78	1000

## Graphs

Gandini 21192718

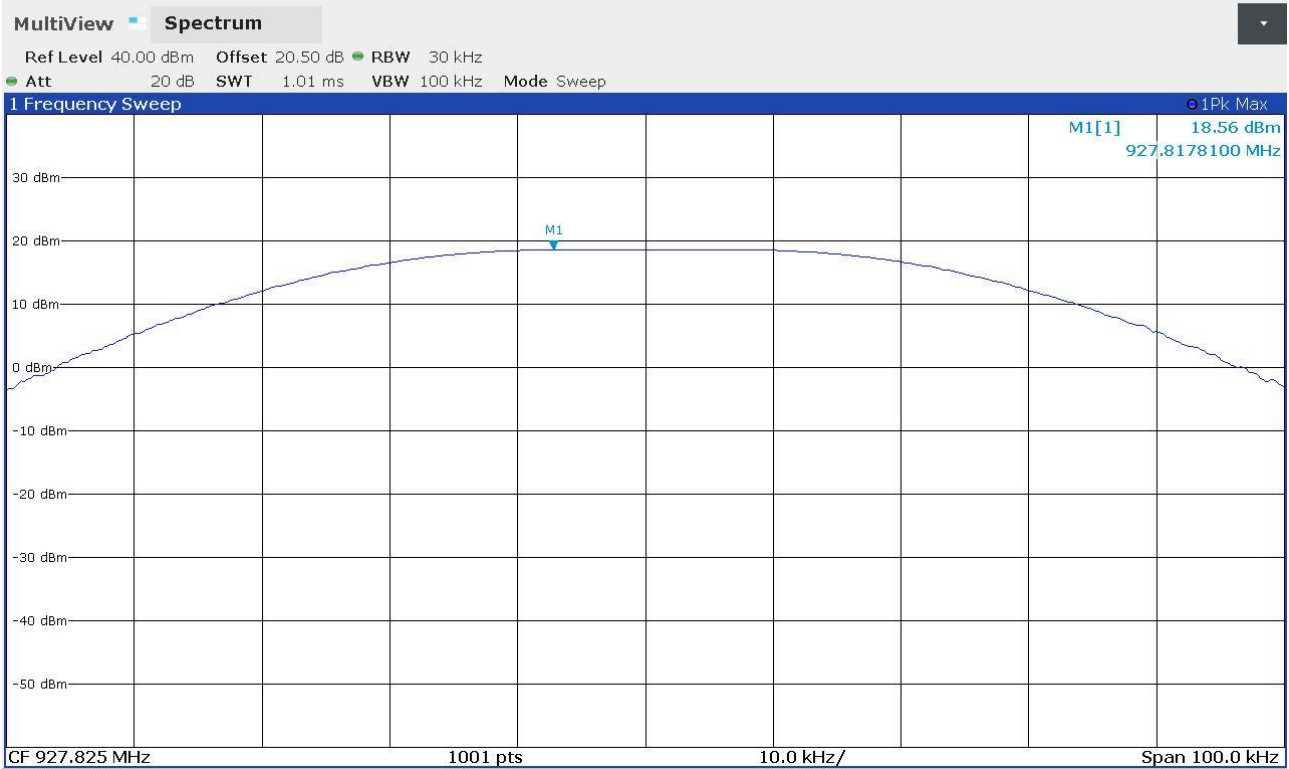

Gandini 21192723

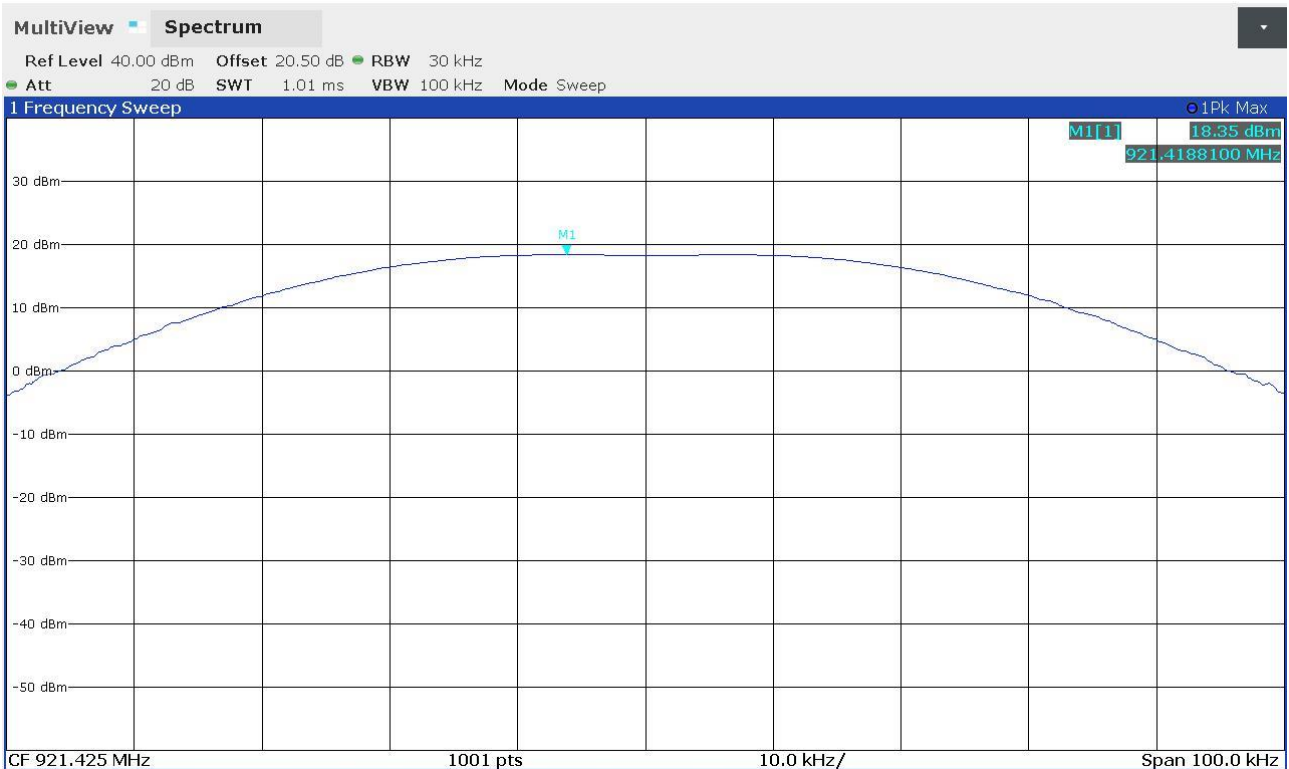

Gandini 21192724

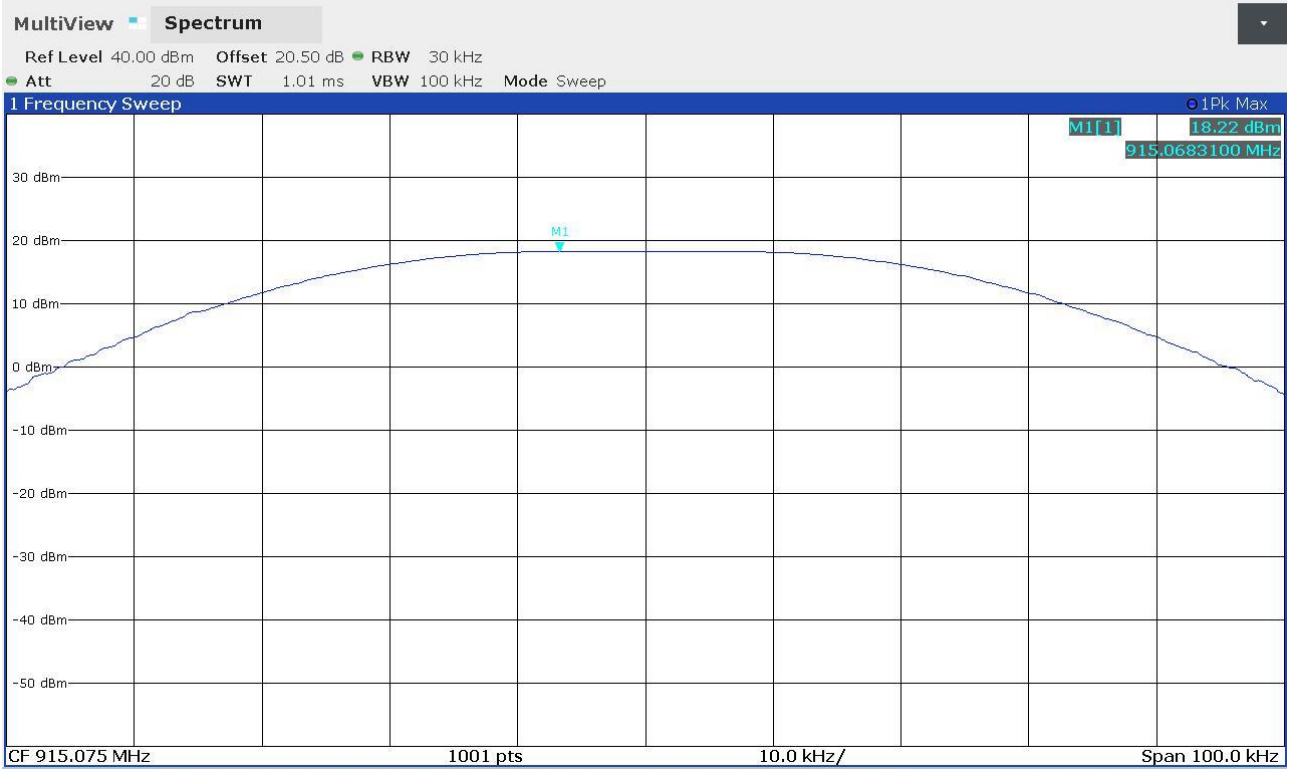



**Attachment 1**
**Instruments list**

<i><b>Id. number</b></i>	<i><b>Manufacturer</b></i>	<i><b>Model</b></i>	<i><b>Description</b></i>	<i><b>Serial number</b></i>	<i><b>Last calibration</b></i>	<i><b>Due date calibration</b></i>
CMC S010	Rohde & Schwarz	ESH3-Z2	Impulses Limiting Device	- - -	January '21	January '22
CMC S108	EMCO	3115	Horn Antenna	9811-5622	June '19	June '22
CMC S127	Schaffner	HLA6120	Loop Antenna	1191	November '18	November '23
CMC S200	Schwarzbeck	NSLK 8128	V-LISN	8128-273	January '21	January '22
CMC S206	Rohde & Schwarz	ESCI 7	EMC Receiver 9KHz-7GHz	100781	January '21	January '22
CMC S260	CMC	Wfr_N	Shielded Cable	Wfr_ant10-1	November '21	November '22
CMC S261	CMC	Wfr_N	Shielded Cable	Wfr_ant20-1	November '21	November '22
CMC S262	CMC	Wfr_N_fix	Shielded Cable	Wfr_fix32-1	November '21	November '22
CMC S263	CMC	Wfr_N_fix	Shielded Cable	Wfr_fix31-1	November '21	November '22
CMC S264	CMC	Wfr_N	Shielded Cable	Wfr_ext03-1	November '21	November '22
CMC S271	Schwarzbeck	BBA 9106 + VHBB 9124	Biconical Antenna (30-300MHz)	831	June '19	June '22
CMC S287	Schwarzbeck	VUSLP 9111B	Log-periodic Antenna (200 MHz-3Ghz)	9111B-203	June '19	June '22
CMC S288	CMC	W_sma_white	Joint Shielded Cable	W_001	November '21	November '22
CMC S295	Rohde & Schwarz	FSW43	Spectrum Analyzer 43GHz	104059	November '19	November '22
CMC S353	Rohde & Schwarz	ESW26	Emi Test Receiver 1 Hz - 26.5 GHz	101492	September '20	September '22

**Attachment 1**
**Measurement uncertainty**

<i>Test</i>	<i>Test Setup</i>	<i>Expanded uncertainty</i>	<i>Note</i>
Conducted emission CISPR 16 LISN 50uH 0,009-0,0150 MHz	PE001_01	3,4 dB	1
Conducted emission CISPR 16 LISN 50uH 0,150-30,0 MHz	PE001_01	3,0 dB	1
Conducted emission CISPR 16 Voltage Probe 0,15-30 MHz	PE001_02	2,3 dB	1
Conducted emission CISPR 16 Current Probe 0,15-30 MHz	PE001_03	2,6 dB	1
Conducted emission CISPR 16 ISN 0,15-30 MHz	PE001_04	4,7 dB	1
Clic CISPR 16 LISN 50uH 0,150-30,0 MHz	PE001_05	2,9 dB	1
Radiated Emission CDNE 30-300 MHz	PE001_06	3,3 dB	1
Disturbance Power 30-300 MHz	PE002_01	3,8 dB	1
Radiated Emission LAS 0,15-30 MHz	PE003_01	2,0 dB	1
Radiated Emission CISPR 16 Loop Ant. 0,15-30 MHz	PE004_01	4,2 dB	1
Radiated Emission CISPR 16 Bicon. Ant. 30-300 MHz	PE004_02	4,1 dB	1
Radiated Emission CISPR 16 LogP. Ant. 300-1000 MHz	PE004_03	3,9 dB	1
Radiated Emission CISPR 16 Horn Ant. 1-18 GHz	PE004_04	4,1 dB	1
Human Exposure to electromagnetic fields	PE005_01	16,7 %	1
Harmonics	PE006_01	10 mA + 2,9 %	1
Flicker	PE007_01	4,36 %	1
Radiated Immunity 80 MHz - 6 GHz	PE102_XX	2,20 dB 0,87 V/m a 3V/m	1
Conducted Immunity 0,15 - 230 MHz	PE105_XX	1,20 dB 0,44 V a 3V	1
AC Magnetic field	PE106_01	1,55 % 0,15 A/m a 10A/m	1
Pulse Magnetic field	PE107_01	6,23 % 18,7 A/m a 300A/m	1
Dumped Magnetic field	PE108_01	6,23 % 1,87 A/m a 30A/m	1
Common mode conducted immunity	PE112_01	2,16 % 0,22 V a 10V	1

**Attachment 1**

<i>Test</i>	<i>Test Setup</i>	<i>Expanded uncertainty</i>	<i>Note</i>
Power/Spurious 9kHz-30MHz	PR001_01	4,2 dB	1
Power/Spurious ERP 30-1000MHz d=10m	PR001_02+03	4,7 dB	1
Misura della potenza EIRP 1-18GHz d=3m	PR001_04+05	4,7 dB	1
Misura della potenza EIRP 18-40GHz d=3m	PR001_06	5,4 dB	1
Frequency error	PR002_01+02	< 1x10 <sup>-7</sup>	1
Timing zero span (1001pts.)	PR002_01+02	0,2 % SWT	1
Modulation bandwidth	PR002_01+02	< 1x10 <sup>-7</sup>	1
Conducted RF power and spurious emission	PR002_01+02	1,1 dB	1
Adjacent channel power	PR002_01+02	1,1 dB	1
Blocking	PR002_01+02	1,1 dB	1

<i>Test</i>	<i>Test Setup</i>	<i>Expanded uncertainty</i>	<i>Note</i>
Electrostatic discharge immunity test	PE101_0X		2
Electrical fast transients / burst immunity test	PE103_0X		2
Surge immunity test	PE104_0X		2
Short interruption immunity test	PE109_01		2
Ring Wave immunity test	PE110_01		2
Low frequency immunity test	PE111_01		2
Dumped Oscillatory immunity test	PE113_01		2
<i>Rev_21_01 date 23/02/2021</i>			

**Note 1:**

The expanded uncertainty reported according to the document EA-4-02 is based on a standard uncertainty multiplied by a coverage factor of k=2, providing a level of confidence of p = 95%

**Note 2:**

It has been demonstrated that the used test equipment meets the specified requirements in the standard with at least a 95% confidence, covering factor k=2

## Attachment 1

### Judgement of compliance

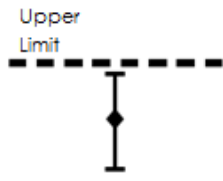
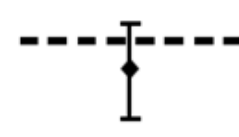
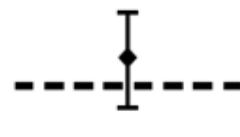
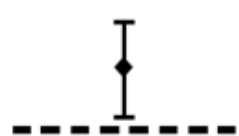
Case 1	Case 2	Case 3	Case 4
 <p>The sample complies with the requirements.</p> <p>The measurement results is within the specification limit when the measurement uncertainty is taken into account.</p>	 <p>The sample complies with the requirements.</p> <p>It is not possible to state compliance using a 95% coverage probability for the expanded uncertainty although the measurement result is below the limit.</p>	 <p>The sample does not comply with the requirements.</p> <p>It is not possible to state compliance using a 95% coverage probability for the expanded uncertainty also the measurement result is upper the limit.</p>	 <p>The sample does not comply with the requirements.</p> <p>The measurement results is outside the specification limit when the measurement uncertainty is taken into account.</p>

In agreement with ILAC-G8:09/2019 cl.4.2.1 Guidelines on Decision Rules and Statements of Conformity

### Quality manual references – Internal procedure

Internal Procedure PM001 rev. 3.1 (Quality Manual) .....	Measure procedure
Internal Procedure INC_M rev. 9.5 (Quality Manual) .....	Measurement uncertainty calculation