

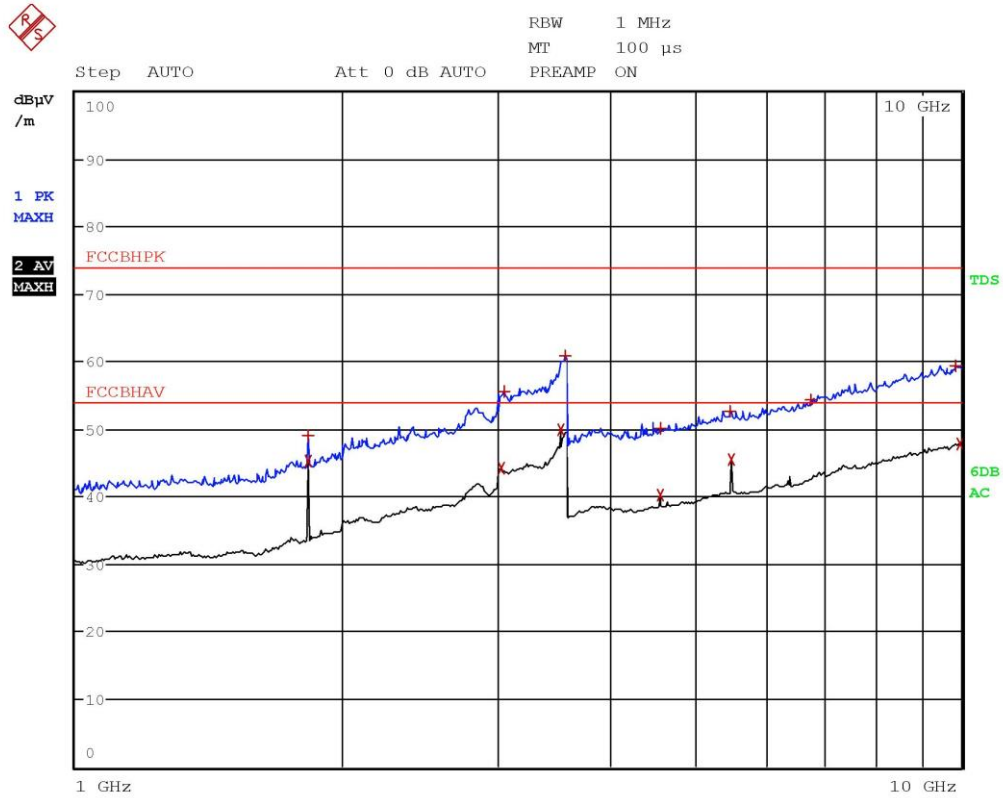

EDIT PEAK LIST (Prescan Results)			
Trace1:	FCCBHPK		
Trace2:	FCCBHAV		
Trace3:	---		
TRACE	FREQUENCY	LEVEL d μ V/m	DELTA LIMIT dB
2 Average	1.83 GHz	41.50	-12.47
1 Max Peak	1.8304 GHz	46.84	-27.13
1 Max Peak	3.0104 GHz	55.87	-18.10
2 Average	3.1528 GHz	44.10	-9.87
2 Average	3.5256 GHz	50.11	-3.86
1 Max Peak	3.5948 GHz	61.21	-12.76
1 Max Peak	4.5676 GHz	50.40	-23.57
2 Average	4.5752 GHz	41.10	-12.87
2 Average	5.4904 GHz	43.96	-10.01
1 Max Peak	6.3192 GHz	53.44	-20.54
2 Average	6.4052 GHz	42.94	-11.03
1 Max Peak	6.7576 GHz	54.54	-19.43
1 Max Peak	9.9604 GHz	60.66	-13.31
2 Average	9.9812 GHz	48.03	-5.94

Gandini 18168114-Vert-Tx Rx Fmin

CMC Centro Misure Compatibilità S.r.l.



Gandini 18168115-Horiz-Tx Rx Fmin

CMC Centro Misure Compatibilità S.r.l.



EDIT PEAK LIST (Prescan Results)			
TRACE	FREQUENCY	LEVEL d μ V/m	DELTA LIMIT dB
Trace1:	FCCBHPK		
Trace2:	FCCBHAV		
Trace3:	---		
2 Average	1.83 GHz	45.25	-8.72
1 Max Peak	1.83 GHz	49.13	-24.85
2 Average	3.0212 GHz	44.15	-9.83
1 Max Peak	3.0476 GHz	55.52	-18.45
2 Average	3.5256 GHz	49.89	-4.08
1 Max Peak	3.5764 GHz	60.87	-13.11
1 Max Peak	4.5728 GHz	50.15	-23.83
2 Average	4.5752 GHz	40.30	-13.67
1 Max Peak	5.4868 GHz	52.69	-21.28
2 Average	5.4904 GHz	45.49	-8.48
1 Max Peak	6.7724 GHz	54.25	-19.72
1 Max Peak	9.8496 GHz	59.44	-14.53
2 Average	9.9728 GHz	47.89	-6.08

Gandini 18168115-Horiz-Tx Rx Fmin

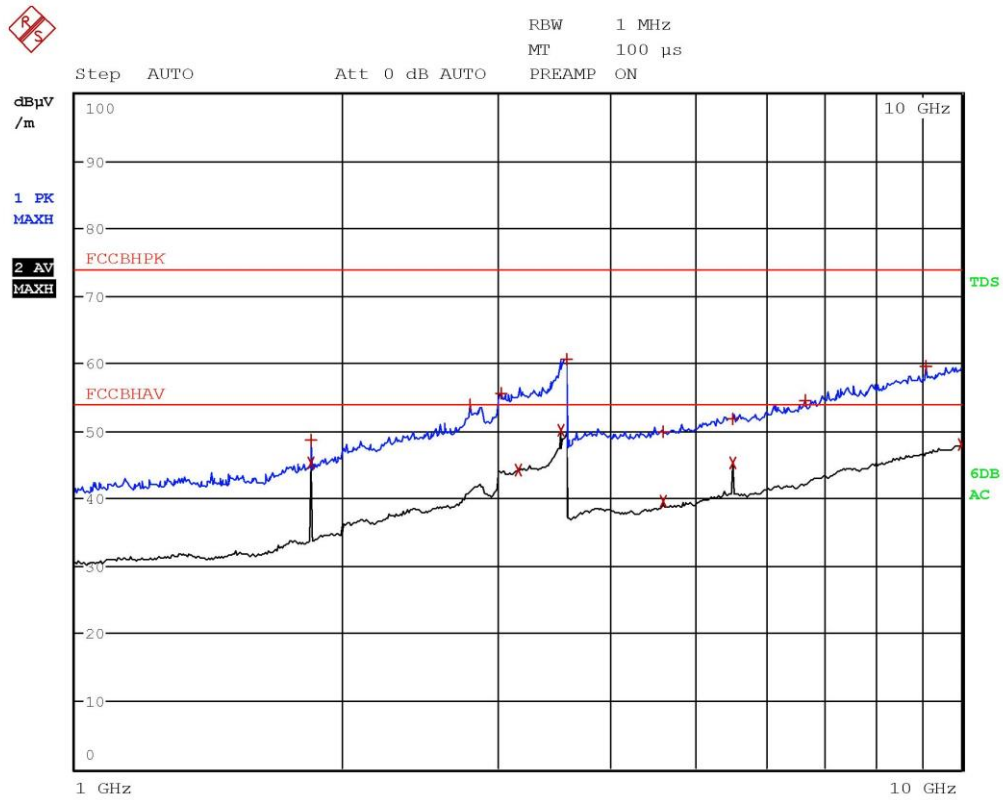

Gandini 18168116-Horiz-Tx Rx Fmid

CMC Centro Misure Compatibilità S.r.l.



PEAK FREQUENCY

4

EDIT PEAK LIST (Prescan Results)			
Trace1:	FCCBHPK		
Trace2:	FCCBHAV		
Trace3:	---		
TRACE	FREQUENCY	LEVEL d μ V/m	DELTA LIMIT dB
2 Average	1.8428 GHz	45.20	-8.77
1 Max Peak	1.8428 GHz	48.64	-25.33
1 Max Peak	2.7896 GHz	53.87	-20.10
1 Max Peak	3.024 GHz	55.49	-18.48
2 Average	3.1612 GHz	44.21	-9.76
2 Average	3.5256 GHz	50.12	-3.85
1 Max Peak	3.5808 GHz	60.59	-13.38
2 Average	4.6068 GHz	39.65	-14.32
1 Max Peak	4.6072 GHz	49.83	-24.14
1 Max Peak	5.512 GHz	51.71	-22.26
2 Average	5.5284 GHz	45.17	-8.80
1 Max Peak	6.6588 GHz	54.52	-19.45
1 Max Peak	9.1116 GHz	59.52	-14.45
2 Average	10 GHz	48.07	-5.90

Gandini 18168116-Horiz-Tx Rx Fmid

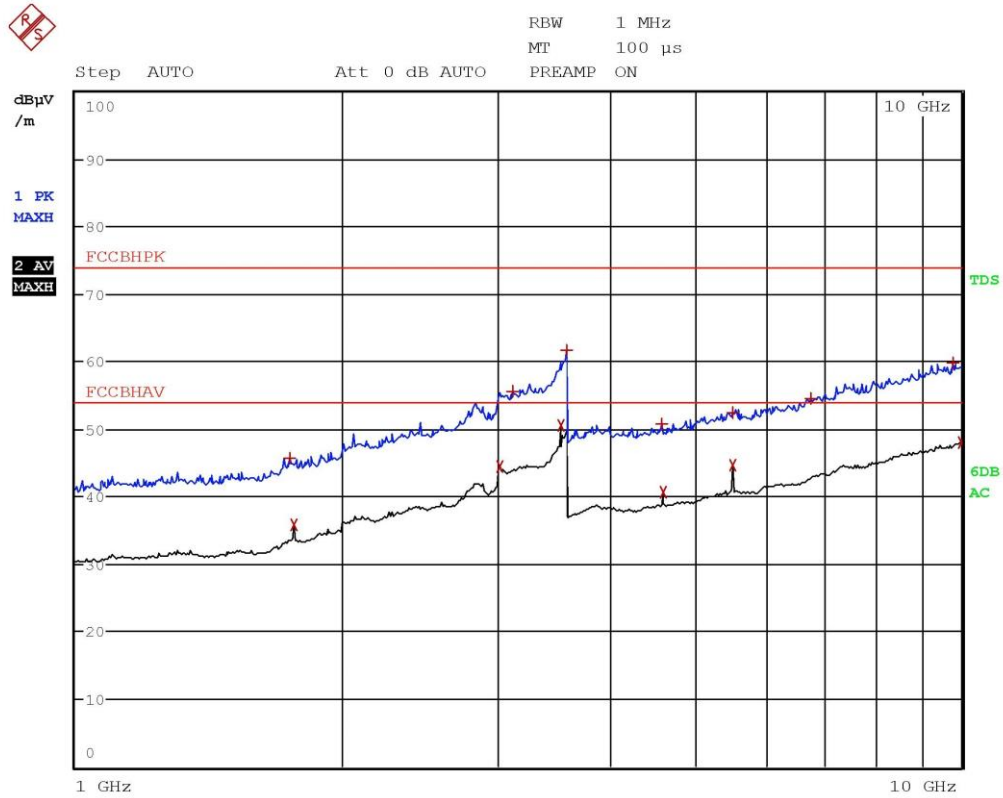

Gandini 18168117-Vert-Tx Rx Fmid

CMC Centro Misure Compatibilità S.r.l.



EDIT PEAK LIST (Prescan Results)			
Trace1:	FCCBHPK		
Trace2:	FCCBHAV		
Trace3:	---		
TRACE	FREQUENCY	LEVEL dBμV/m	DELTA LIMIT dB
1 Max Peak	1.7452 GHz	45.66	-28.31
2 Average	1.7668 GHz	35.85	-18.13
2 Average	3.0088 GHz	44.32	-9.65
1 Max Peak	3.1164 GHz	55.60	-18.37
2 Average	3.5256 GHz	50.49	-3.48
1 Max Peak	3.5992 GHz	61.70	-12.27
1 Max Peak	4.594 GHz	50.70	-23.27
2 Average	4.6072 GHz	40.54	-13.43
1 Max Peak	5.5284 GHz	52.43	-21.54
2 Average	5.5284 GHz	44.71	-9.26
1 Max Peak	6.7624 GHz	54.54	-19.43
1 Max Peak	9.79 GHz	59.67	-14.30
2 Average	9.9936 GHz	48.00	-5.97

Gandini 18168117-Vert-Tx Rx Fmid

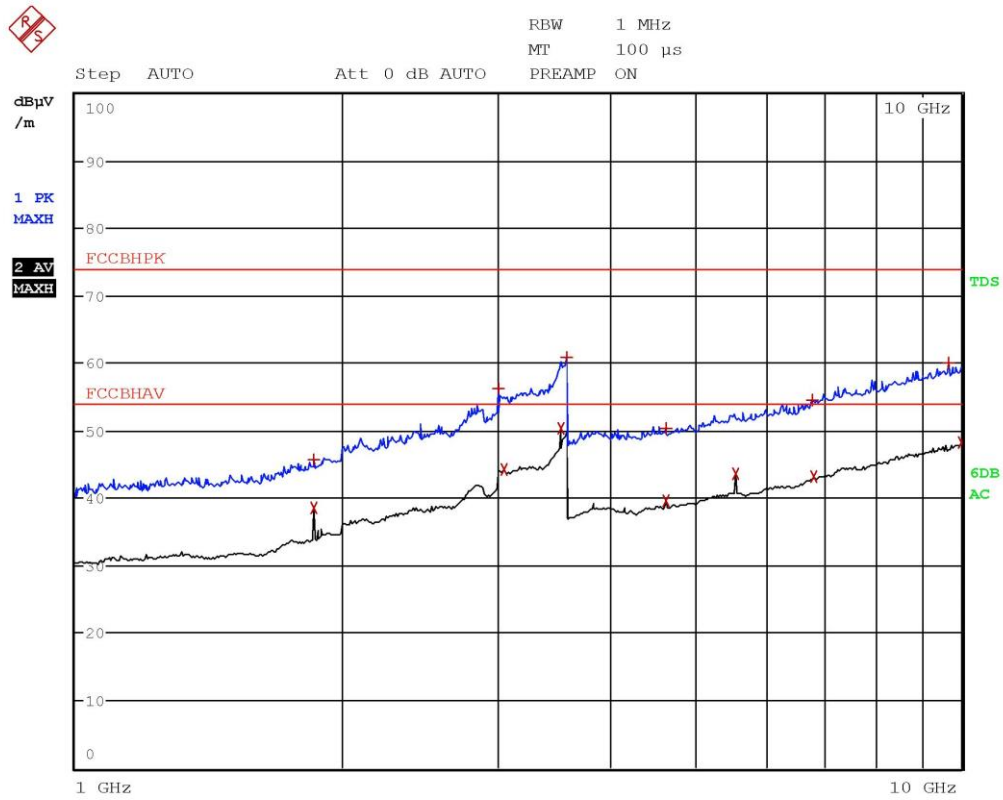

Gandini 18168118-Vert-Tx Rx Fmax

CMC Centro Misure Compatibilità S.r.l.



EDIT PEAK LIST (Prescan Results)			
Trace1:	FCCBHPK		
Trace2:	FCCBHAV		
Trace3:	---		
TRACE	FREQUENCY	LEVEL dBμV/m	DELTA LIMIT dB
2 Average	1.8556 GHz	38.61	-15.36
1 Max Peak	1.8556 GHz	45.65	-28.32
1 Max Peak	3.0064 GHz	56.17	-17.81
2 Average	3.0456 GHz	44.28	-9.69
2 Average	3.5256 GHz	50.39	-3.58
1 Max Peak	3.588 GHz	60.83	-13.14
1 Max Peak	4.6384 GHz	50.32	-23.65
2 Average	4.6388 GHz	39.54	-14.43
2 Average	5.5668 GHz	43.53	-10.44
1 Max Peak	6.7992 GHz	54.49	-19.49
2 Average	6.8072 GHz	43.11	-10.86
1 Max Peak	9.6704 GHz	60.06	-13.91
2 Average	9.9812 GHz	48.22	-5.75

Gandini 18168118-Vert-Tx Rx Fmax

CMC Centro Misure Compatibilità S.r.l.

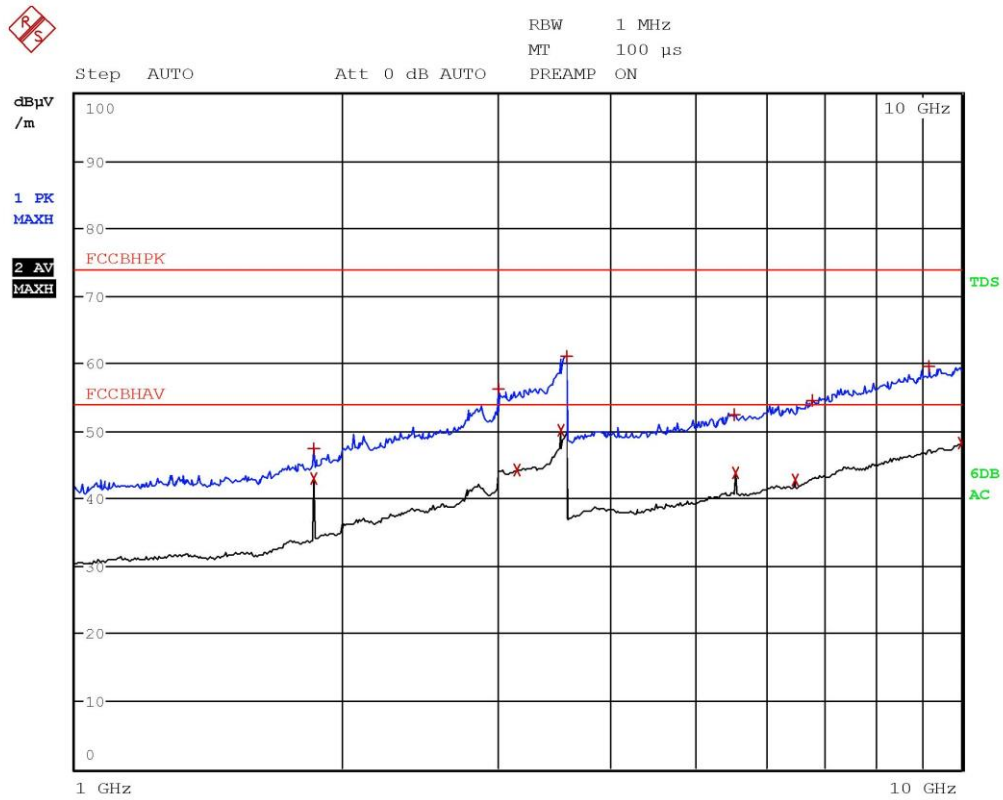

Gandini 18168119-Horiz-Tx Rx Fmax

CMC Centro Misure Compatibilità S.r.l.



EDIT PEAK LIST (Prescan Results)			
Trace1:	FCCBHPK		
Trace2:	FCCBHAV		
Trace3:	---		
TRACE	FREQUENCY	LEVEL dBμV/m	DELTA LIMIT dB
2 Average	1.8556 GHz	42.90	-11.07
1 Max Peak	1.8556 GHz	47.47	-26.50
1 Max Peak	3.0016 GHz	56.19	-17.78
2 Average	3.1556 GHz	44.22	-9.75
2 Average	3.5256 GHz	50.05	-3.92
1 Max Peak	3.6 GHz	61.06	-12.91
1 Max Peak	5.546 GHz	52.47	-21.50
2 Average	5.5668 GHz	43.88	-10.09
2 Average	6.4948 GHz	42.64	-11.33
1 Max Peak	6.7764 GHz	54.45	-19.52
1 Max Peak	9.1904 GHz	59.45	-14.52
2 Average	9.9908 GHz	48.13	-5.84

Gandini 18168119-Horiz-Tx Rx Fmax

Result: The requirements are met

CMC Centro Misure Compatibilità S.r.l.



11.3 20 dB bandwidth

Test set-up and execution

- FCC Rules and Regulation; Titles 47 Part 15.247
- ANSI C63.10 cl. 7.8.7
- Internal procedure PM001
- See clause 4 of this test report

Test configuration and test method

Test site:
 Laboratory

Auxiliary equipment:
 See clause 4 of this test report

EUT exercising

See clause 4 of this test report

Test equipment used

CMC S295
 Measurement uncertainty: See clause 7 of this test report

Test specification

See FCC Part 15.247

Environmental conditions

<i>Temperature (°C)</i>	<i>Atmospheric pressure (kPa)</i>	<i>Relative humidity (%)</i>
22	100	45

Acceptance limits: The maximum allowed 20 dB bandwidth of the hopping channel is 500 kHz

Setup

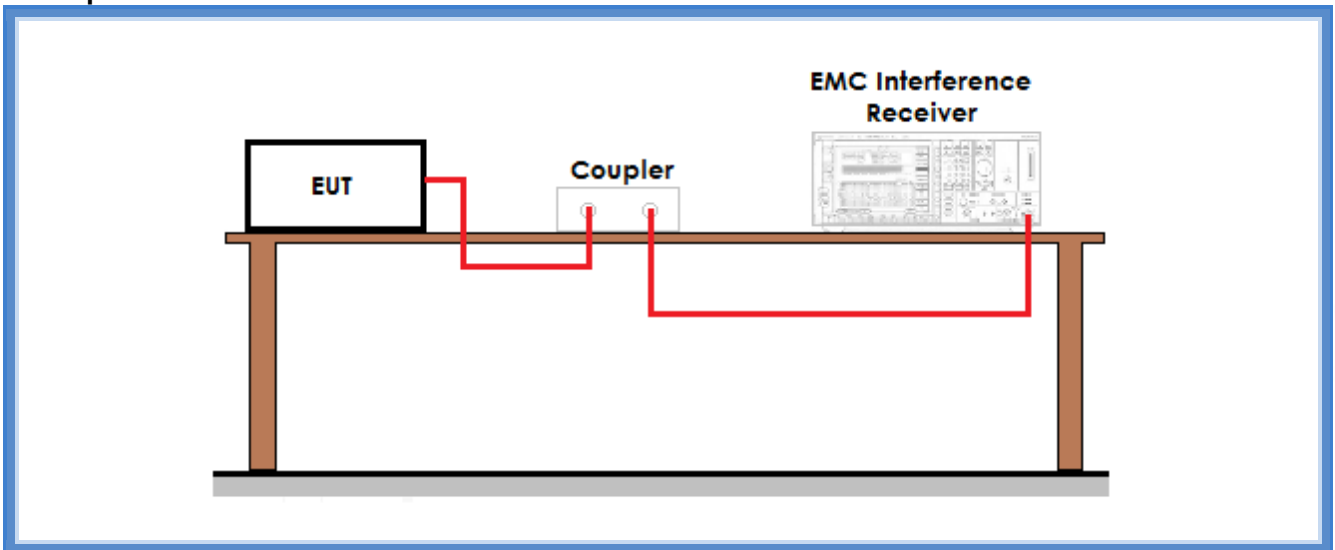

Result

Frequency (MHz)	Graphs	20 dB bandwidth (kHz)	Maximum 20 dB bandwidth allowed (kHz)	Results
915,05	G18168121	17,432	500	Complies
921,40	G18168130	17,482	500	Complies
927,80	G18168127	17,532	500	Complies



Graphs

Gandini 18168121



Gandini 18168127





Gandini 18168130



Result: The requirements are met



11.4 Channel separation

Test set-up and execution

- FCC Rules and Regulation; Titles 47 Part 15.247
- ANSI C63.10 cl. 7.8.2
- Internal procedure PM001
- See clause 4 of this test report

Test configuration and test method

Test site:
 Laboratory

Auxiliary equipment:
 See clause 4 of this test report

EUT exercising

See clause 4 of this test report

Test equipment used

CMC S295
 Measurement uncertainty: See clause 7 of this test report

Test specification

See FCC Part 15.247

Environmental conditions

<i>Temperature (°C)</i>	<i>Atmospheric pressure (kPa)</i>	<i>Relative humidity (%)</i>
20	100	42

Acceptance limits: frequency hopping systems shall have hopping channel carrier frequencies separated by a minimum of 25 kHz or the 20 dB bandwidth of the hopping channel, whichever is greater. Alternatively, frequency hopping systems operating in the 2400–2483,5 MHz band may have hopping channel carrier frequencies that are separated by 25 kHz or two-thirds of the 20 dB bandwidth of the hopping channel, whichever is greater, provided the systems operate with an output power no greater than 125 mW

Setup

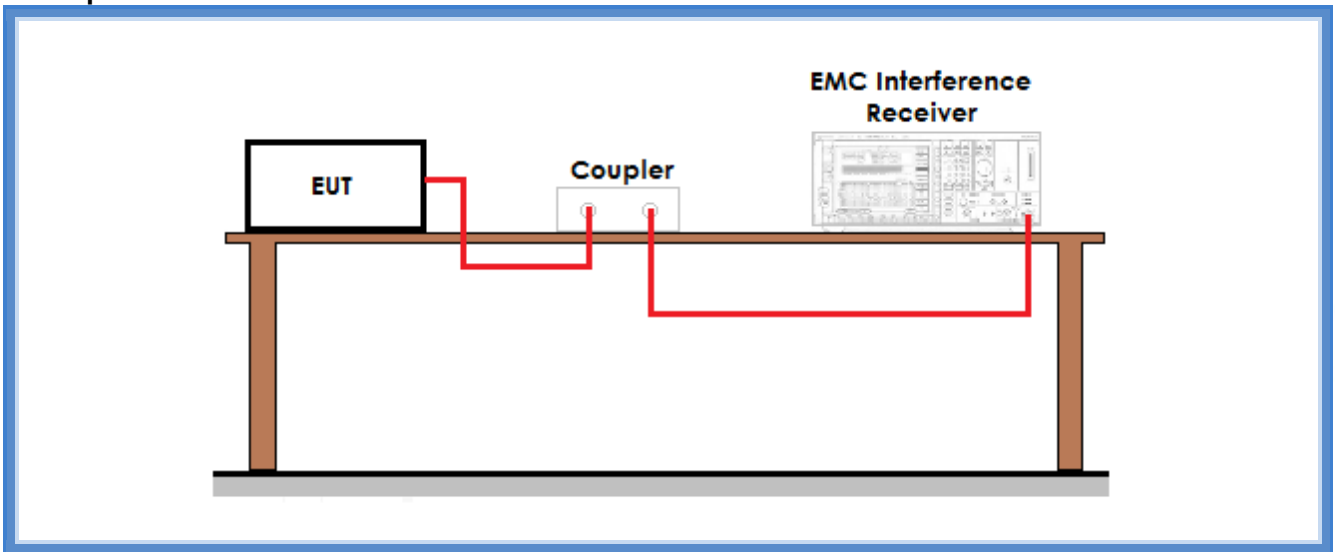

Result

Frequency band (MHz)	Graphs	Channel separation (kHz)	Minimum channel separation required (kHz)	Results
902 – 928	G18168133	99,9	25	Complies



Graphs

Gandini 18168133

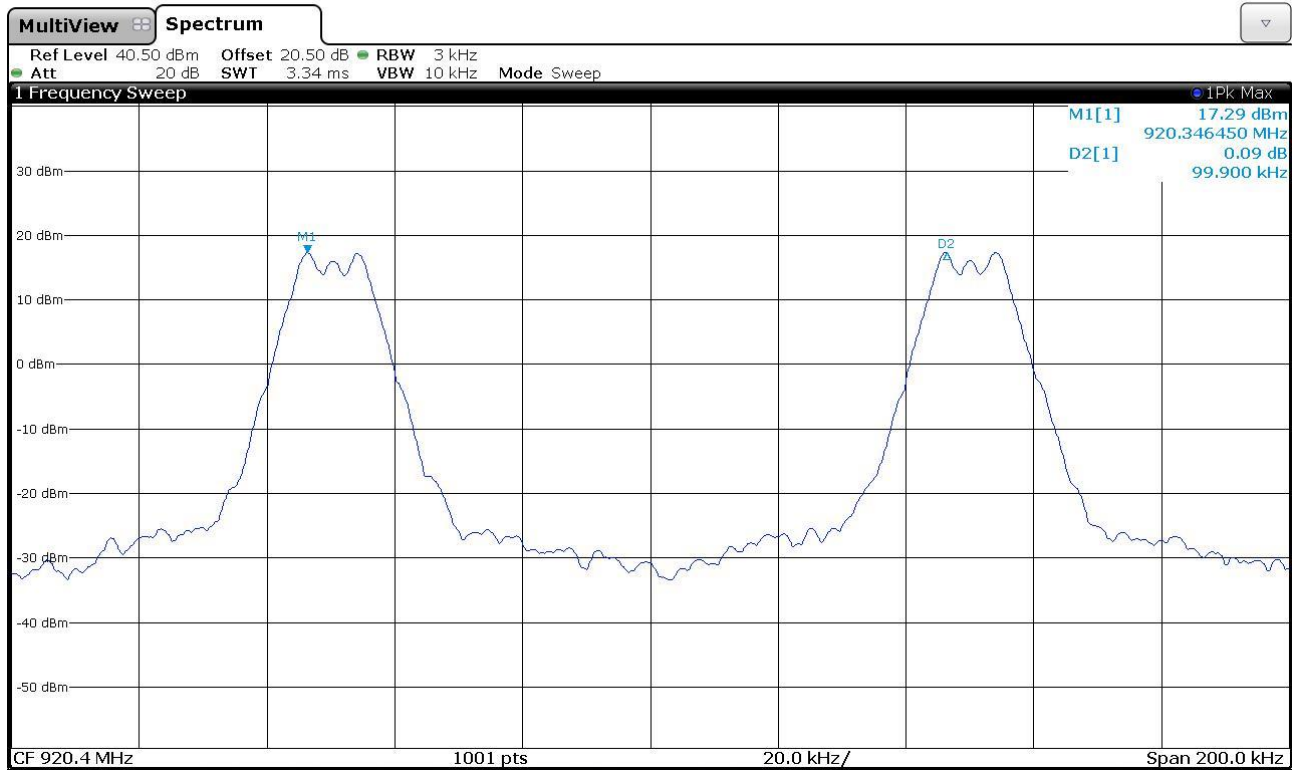

Result: The requirements are met



11.5 Number of hopping channels

Test set-up and execution

- FCC Rules and Regulation; Titles 47 Part 15.247
- ANSI C63.10 cl. 7.8.3
- Internal procedure PM001
- See clause 4 of this test report

Test configuration and test method

Test site:
 Laboratory

Auxiliary equipment:
 See clause 4 of this test report

EUT exercising

See clause 4 of this test report

Test equipment used

CMC S295
 Measurement uncertainty: See clause 7 of this test report

Test specification

See FCC Part 15.247

Environmental conditions

<i>Temperature (°C)</i>	<i>Atmospheric pressure (kPa)</i>	<i>Relative humidity (%)</i>
20	100	42

Acceptance limits: for frequency hopping systems operating in the 902–928 MHz band: if the 20 dB bandwidth of the hopping channel is less than 250 kHz, the system shall use at least 50 hopping frequencies. If the 20 dB bandwidth of the hopping channel is 250 kHz or greater, the system shall use at least 25 hopping frequencies. Frequency hopping systems in the 2400–2483.5 MHz band shall use at least 15 channels.

Setup

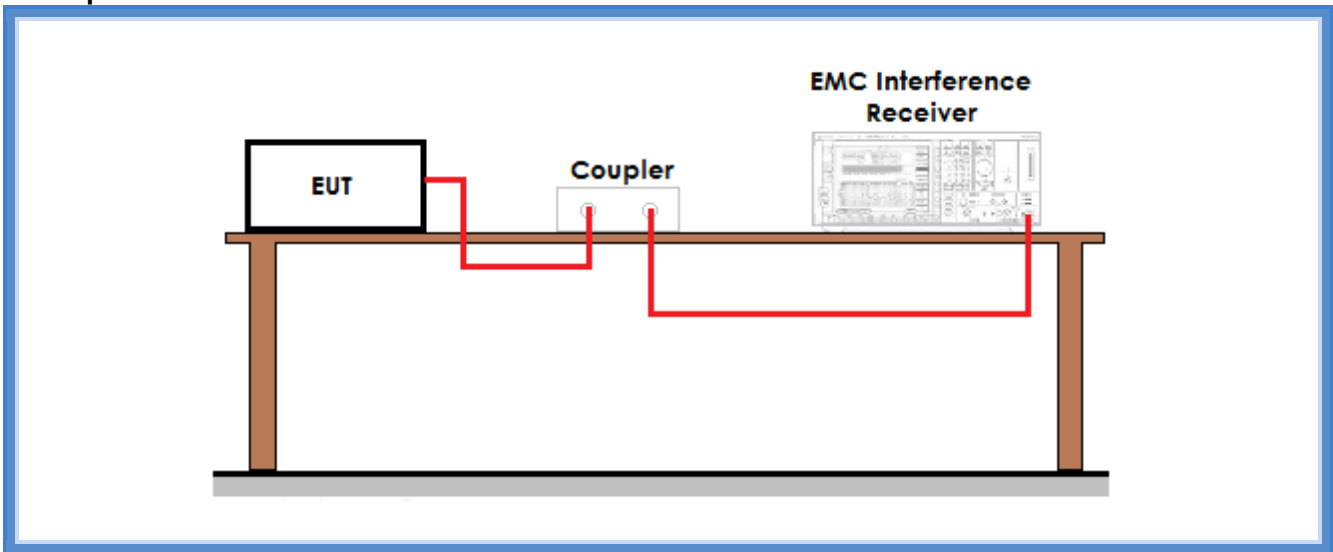

Result

Frequency band (MHz)	Graphs	Number of hopping channels	Minimum number of hopping channels required	Results
902 – 928	G18168137 and G18168138	128	50	Complies

The RRC may operate between 915.050 MHz (min. useable frequency) and 927.800 MHz (max. useable frequency) on a set of channels positioned at 50 kHz multiples (e.g. 915.050, 915.100, 915.150...927.750, 927.800).

This gives a raster of 256 possible channels positions where to place the channels actually scanned in any hopping sequence.

This doesn't imply that all 256 channels are used in every hopping sequence.

On the contrary, a smaller set of channels is usually chosen: while preserving maximum spread of channels over the available band, it is wise to avoid evenly spaced sets, so as to guarantee maximum mitigation of intermodulation effects between similar systems operating in the same area.

In any case, minimum number of channel in a set is 64, which is exceeding the specification in FCC 15.247.

For example consider the following 4 tables which are used for series production.



#	Ch	MHz	#	Ch	MHz	#	Ch	MHz	#	Ch	MHz
0	1	915,100	16	65	918,300	32	129	921,500	48	193	924,700
1	6	915,350	17	70	918,550	33	134	921,750	49	198	924,950
2	10	915,550	18	74	918,750	34	138	921,950	50	202	925,150
3	13	915,700	19	77	918,900	35	141	922,100	51	205	925,300
4	17	915,900	20	81	919,100	36	145	922,300	52	209	925,500
5	22	916,150	21	86	919,350	37	150	922,550	53	214	925,750
6	26	916,350	22	90	919,550	38	154	922,750	54	218	925,950
7	29	916,500	23	93	919,700	39	157	922,900	55	221	926,100
8	33	916,700	24	97	919,900	40	161	923,100	56	225	926,300
9	38	916,950	25	102	920,150	41	166	923,350	57	230	926,550
10	42	917,150	26	106	920,350	42	170	923,550	58	234	926,750
11	45	917,300	27	109	920,500	43	173	923,700	59	237	926,900
12	49	917,500	28	113	920,700	44	177	923,900	60	241	927,100
13	54	917,750	29	118	920,950	45	182	924,150	61	246	927,350
14	58	917,950	30	122	921,150	46	186	924,350	62	250	927,550
15	61	918,100	31	125	921,300	47	189	924,500	63	253	927,700

Table 1. Channel group A (64 channels, 150 kHz minimum channel spacing)

#	Ch	MHz	#	Ch	MHz	#	Ch	MHz	#	Ch	MHz
0	3	915,200	16	67	918,400	32	131	921,600	48	195	924,800
1	8	915,450	17	72	918,650	33	136	921,850	49	200	925,050
2	12	915,650	18	76	918,850	34	140	922,050	50	204	925,250
3	15	915,800	19	79	919,000	35	143	922,200	51	207	925,400
4	19	916,000	20	83	919,200	36	147	922,400	52	211	925,600
5	24	916,250	21	88	919,450	37	152	922,650	53	216	925,850
6	28	916,450	22	92	919,650	38	156	922,850	54	220	926,050
7	31	916,600	23	95	919,800	39	159	923,000	55	223	926,200
8	35	916,800	24	99	920,000	40	163	923,200	56	227	926,400
9	40	917,050	25	104	920,250	41	168	923,450	57	232	926,650
10	44	917,250	26	108	920,450	42	172	923,650	58	236	926,850
11	47	917,400	27	111	920,600	43	175	923,800	59	239	927,000
12	51	917,600	28	115	920,800	44	179	924,000	60	243	927,200
13	56	917,850	29	120	921,050	45	184	924,250	61	248	927,450
14	60	918,050	30	124	921,250	46	188	924,450	62	252	927,650
15	63	918,200	31	127	921,400	47	191	924,600	63	255	927,800

Table 2. Channel group B (64 channels, 150 kHz minimum channel spacing)



#	Ch	MHz	#	Ch	MHz	#	Ch	MHz	#	Ch	MHz	#	Ch	MHz
0	0	915,050	16	57	917,900	32	113	920,700	48	169	923,500	64	225	926,300
1	3	915,200	17	61	918,100	33	115	920,800	49	171	923,600	65	229	926,500
2	6	915,350	18	64	918,250	34	120	921,050	50	176	923,850	66	232	926,650
3	10	915,550	19	66	918,350	35	124	921,250	51	178	923,950	67	234	926,750
4	15	915,800	20	71	918,600	36	127	921,400	52	183	924,200	68	239	927,000
5	19	916,000	21	73	918,700	37	129	921,500	53	187	924,400	69	241	927,100
6	22	916,150	22	78	918,950	38	134	921,750	54	190	924,550	70	246	927,350
7	24	916,250	23	82	919,150	39	136	921,850	55	192	924,650	71	250	927,550
8	29	916,500	24	85	919,300	40	141	922,100	56	197	924,900	72	253	927,700
9	31	916,600	25	87	919,400	41	145	922,300	57	199	925,000	73	255	927,800
10	36	916,850	26	92	919,650	42	148	922,450	58	204	925,250			
11	40	917,050	27	94	919,750	43	150	922,550	59	208	925,450			
12	43	917,200	28	99	920,000	44	155	922,800	60	211	925,600			
13	45	917,300	29	103	920,200	45	157	922,900	61	213	925,700			
14	50	917,550	30	106	920,350	46	162	923,150	62	218	925,950			
15	52	917,650	31	108	920,450	47	166	923,350	63	220	926,050			

Table 3. Channel group C (74 channels, 100 kHz minimum channel spacing)

#	Ch	MHz	#	Ch	MHz	#	Ch	MHz	#	Ch	MHz	#	Ch	MHz	#	Ch	MHz
0	1	915,100	16	48	917,450	32	96	919,850	48	145	922,300	64	192	924,650	80	244	927,250
1	3	915,200	17	51	917,600	33	100	920,050	49	147	922,400	65	195	924,800	81	246	927,350
2	6	915,350	18	55	917,800	34	102	920,150	50	150	922,550	66	199	925,000	82	249	927,500
3	10	915,550	19	57	917,900	35	105	920,300	51	154	922,750	67	201	925,100	83	253	927,700
4	12	915,650	20	60	918,050	36	109	920,500	52	156	922,850	68	204	925,250	84	255	927,800
5	15	915,800	21	64	918,250	37	111	920,600	53	159	923,000	69	208	925,450			
6	19	916,000	22	66	918,350	38	114	920,750	54	163	923,200	70	210	925,550			
7	21	916,100	23	69	918,500	39	118	920,950	55	165	923,300	71	213	925,700			
8	24	916,250	24	73	918,700	40	120	921,050	56	168	923,450	72	217	925,900			
9	28	916,450	25	75	918,800	41	123	921,200	57	172	923,650	73	219	926,000			
10	30	916,550	26	78	918,950	42	127	921,400	58	174	923,750	74	222	926,150			
11	33	916,700	27	82	919,150	43	129	921,500	59	177	923,900	75	226	926,350			
12	37	916,900	28	84	919,250	44	132	921,650	60	181	924,100	76	231	926,600			
13	39	917,000	29	87	919,400	45	136	921,850	61	183	924,200	77	235	926,800			
14	42	917,150	30	91	919,600	46	138	921,950	62	186	924,350	78	237	926,900			
15	46	917,350	31	93	919,700	47	141	922,100	63	190	924,550	79	240	927,050			

Table 4. Channel group D (85 channels, 100 kHz minimum channel spacing).

For laboratory tests at CMC, a special programming is provided; anyway we deem it representative of any real world hopping sequence that can be programmed into the devices.

First, special programming allows fixed frequency measurements at min, med and max operating frequency; this is not available for series production units, but is required for testing.

Then two evenly spaced hopping sequences of 64 channels are provided, one including the min freq channel at 915,050 MHz, the other including the max freq channel at 927,800 MHz.

Although they are not available for series production units, both these hopping sequences are suitable for valid measurements of FH timing parameters. In fact, FH Timing parameters measurements is not dependent on channel positioning.



Graphs

Gandini 18168137

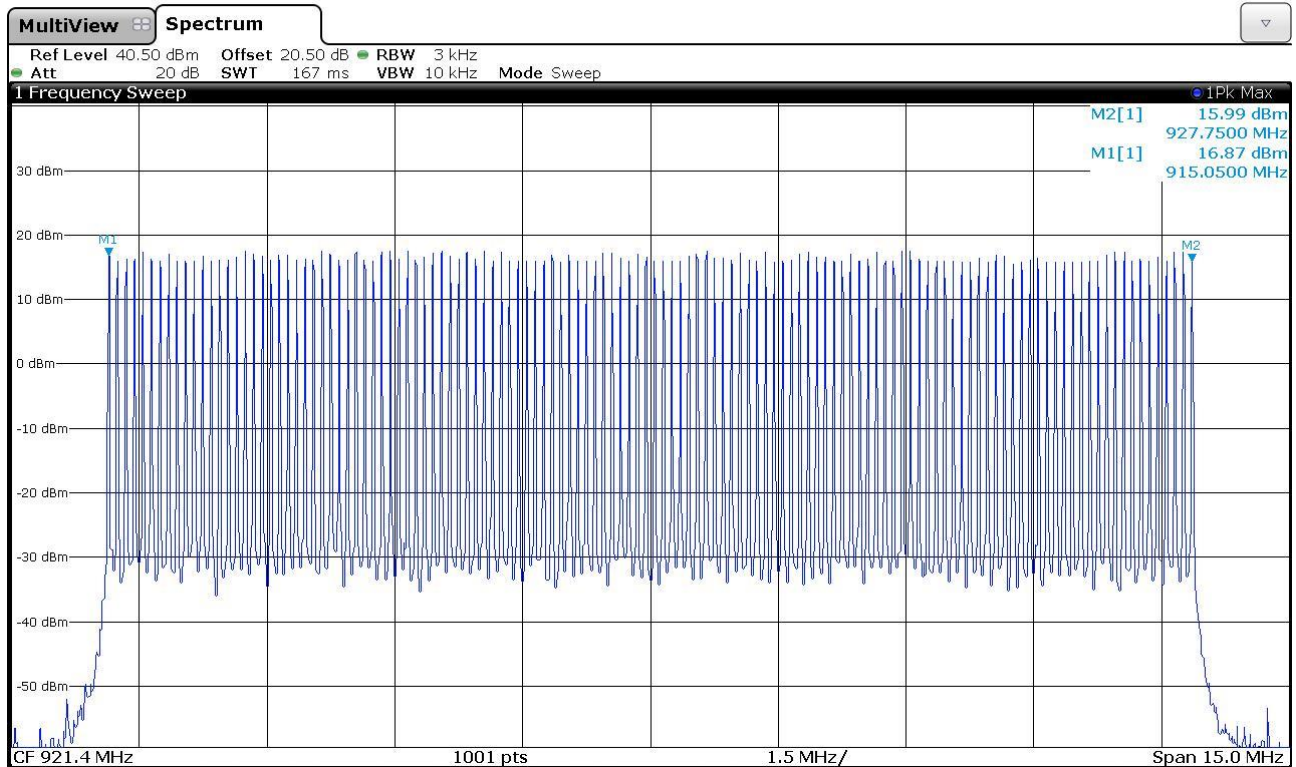



Gandini 18168138

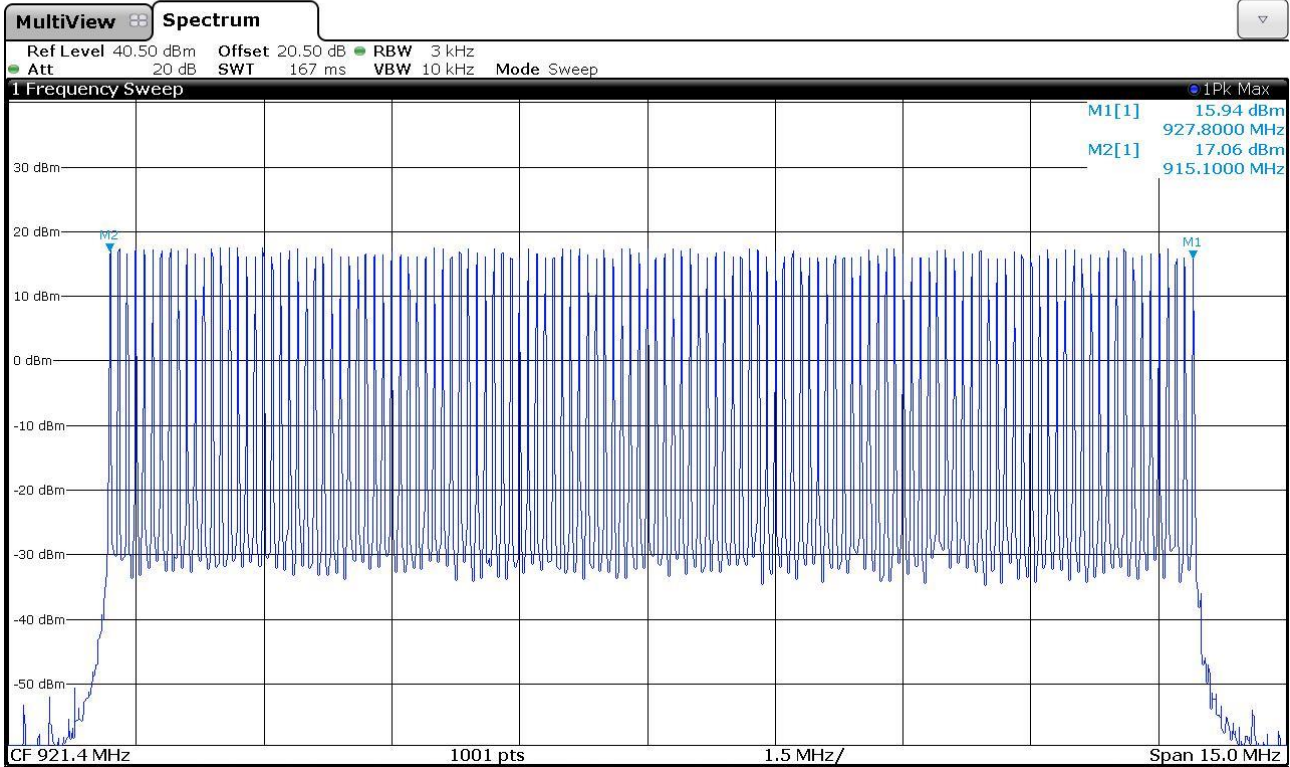

Result: The requirements are met



11.6 Time of occupancy

Test set-up and execution

- FCC Rules and Regulation; Titles 47 Part 15.247
- ANSI C63.10 cl. 7.8.4
- Internal procedure PM001
- See clause 4 of this test report

Test configuration and test method

Test site:
 Laboratory

Auxiliary equipment:
 See clause 4 of this test report

EUT exercising

See clause 4 of this test report

Test equipment used

CMC S295
 Measurement uncertainty: See clause 7 of this test report

Test specification

See FCC Part 15.247

Environmental conditions

<i>Temperature (°C)</i>	<i>Atmospheric pressure (kPa)</i>	<i>Relative humidity (%)</i>
22	100	42

Acceptance limits:

For frequency hopping systems operating in the 902–928 MHz band: if the 20 dB bandwidth of the hopping channel is less than 250 kHz, the system shall use at least 50 hopping frequencies and the average time of occupancy on any frequency shall not be greater than 0,4 seconds within a 20 second period; if the 20 dB bandwidth of the hopping channel is 250 kHz or greater, the system shall use at least 25 hopping frequencies and the average time of occupancy on any frequency shall not be greater than 0,4 seconds within a 10 second period

Setup

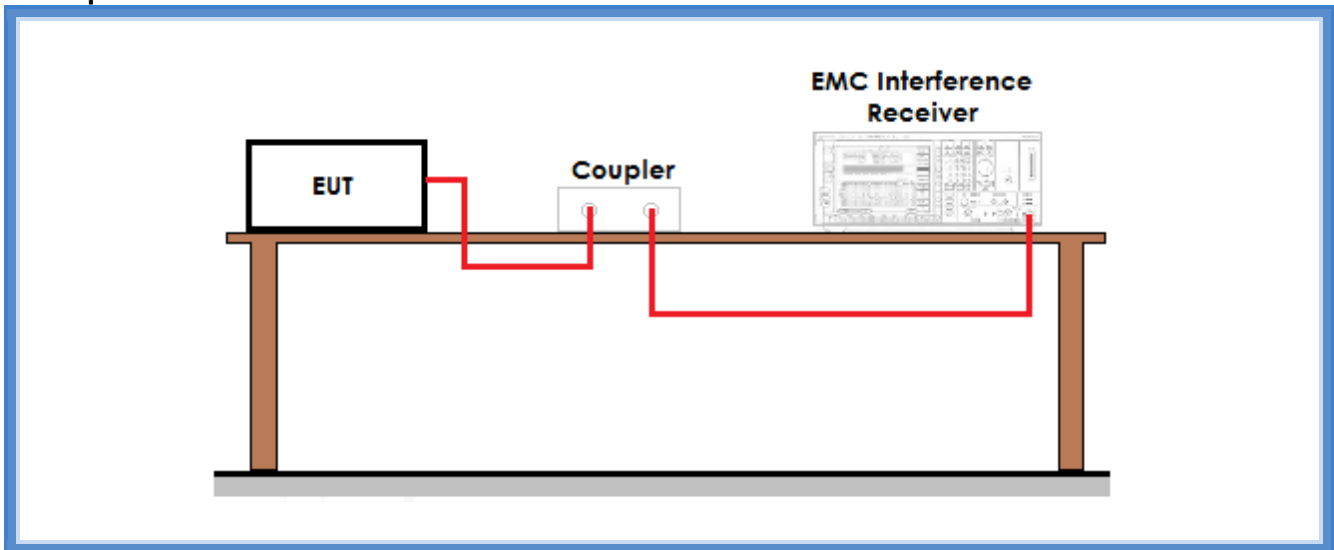

Result

Frequency (MHz)	Graphs	Dwell time (ms)
920,35	G18168134	24,25

Frequency (MHz)	Graphs	Number of transmissions
920,35	G18168135 and G18168136	4

Remarks: only the highest peaks have been considered. The lowest peaks are due to the auxiliary receiver unit

Time of occupancy (Dwell time x Nr. transmissions)	Maximum allowed time of occupancy	Results
97 ms	400 ms	Complies



Graphs

Gandini 18168134

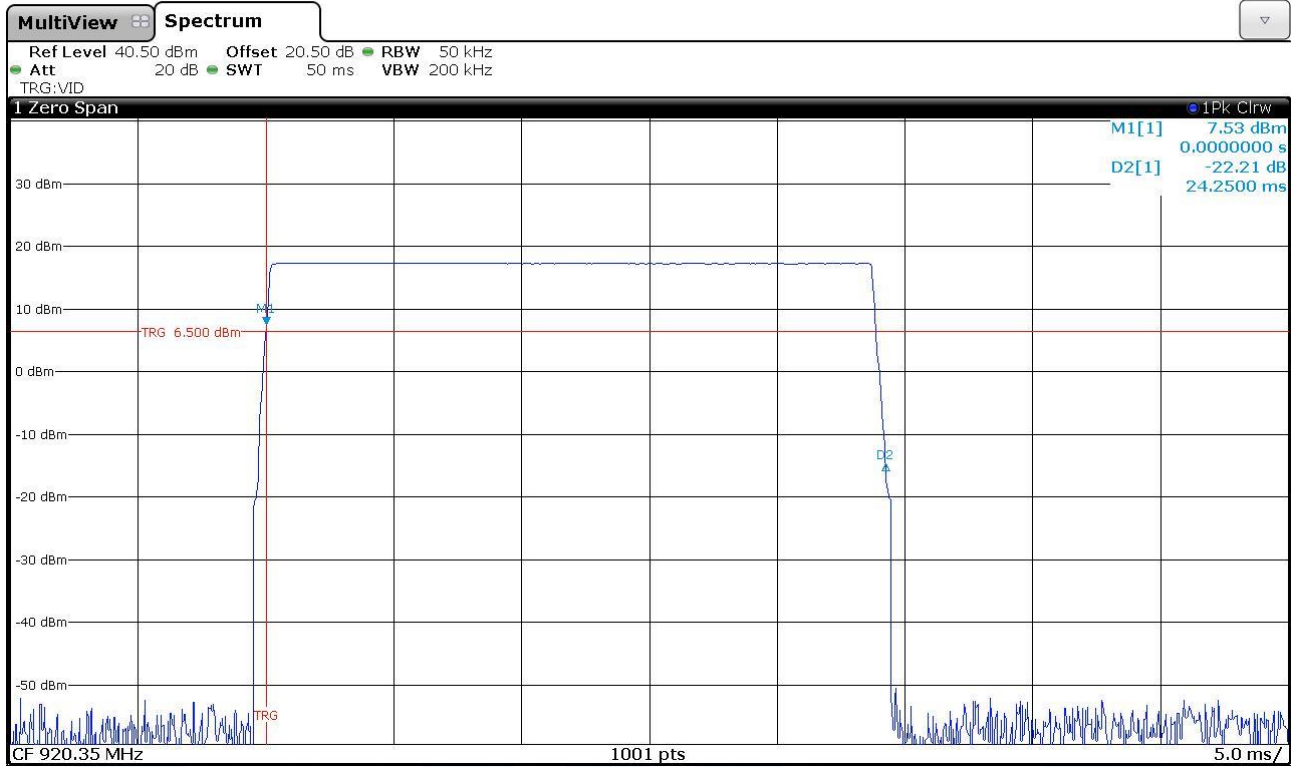

Gandini 18168135

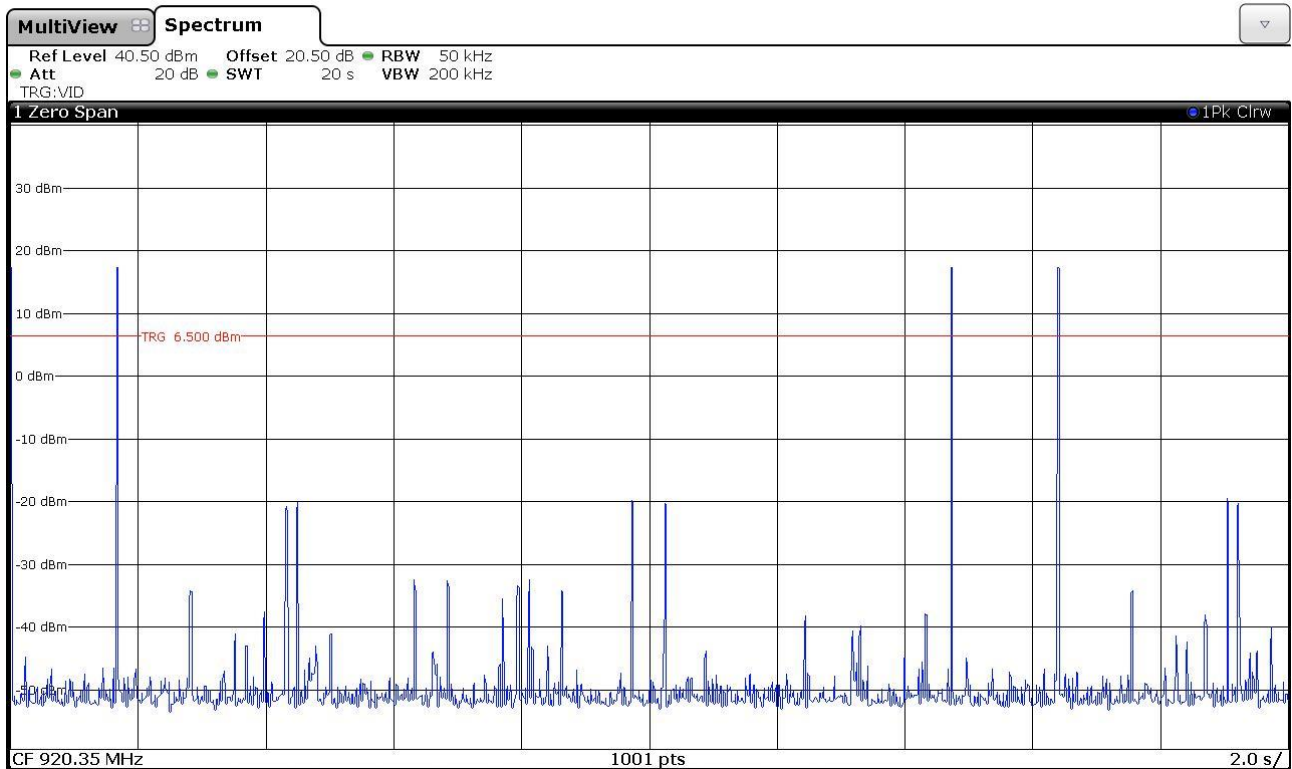



Gandini 18168136

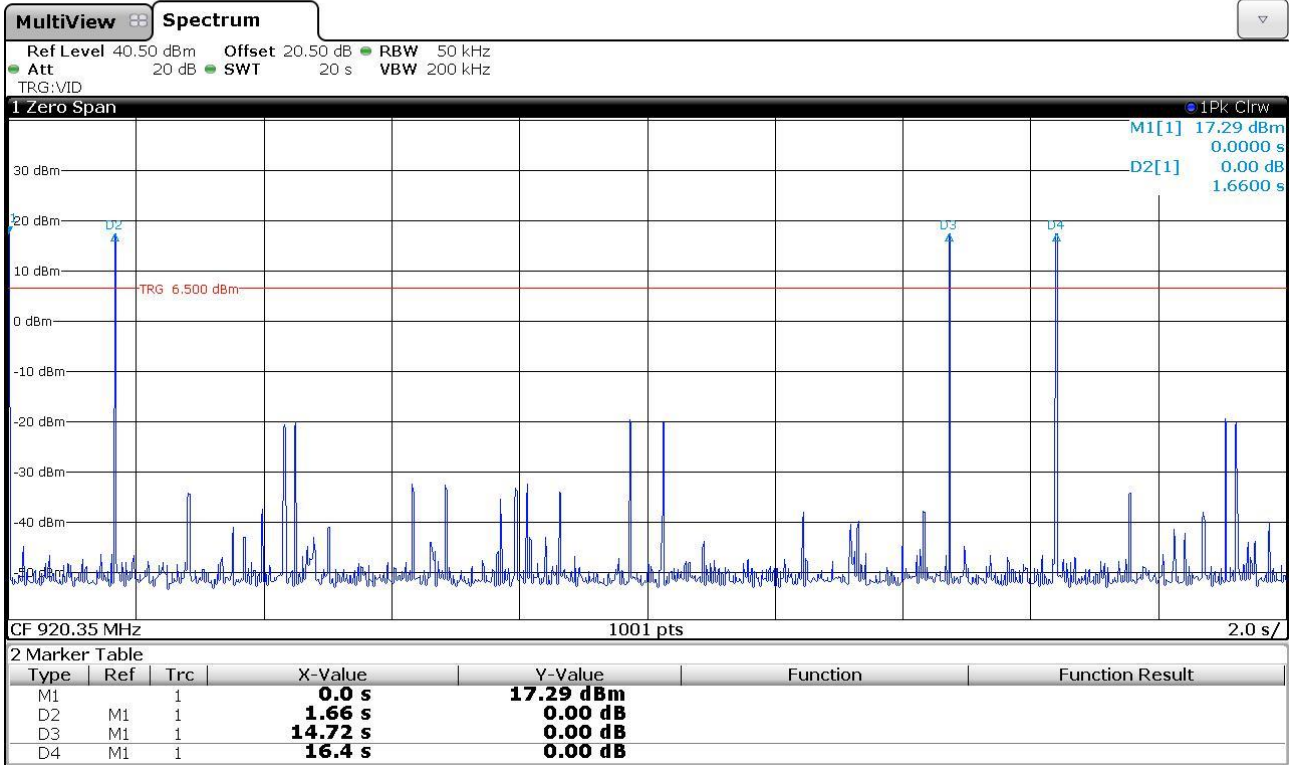

Result: The requirements are met



11.7 Band edge

Test set-up and execution

- FCC Rules and Regulation; Titles 47 Part 15.247
- ANSI C63.10 cl. 7.8.6
- Internal procedure PM001
- See clause 4 of this test report

Test configuration and test method

Test site:
 Laboratory

Auxiliary equipment:
 See clause 4 of this test report

EUT exercising

See clause 4 of this test report

Test equipment used

CMC S295
 Measurement uncertainty: See clause 7 of this test report

Test specification

See FCC Part 15.247

Environmental conditions

<i>Temperature (°C)</i>	<i>Atmospheric pressure (kPa)</i>	<i>Relative humidity (%)</i>
22	100	45

Acceptance limits: operation within the band 902 – 928 MHz

CMC Centro Misure Compatibilità S.r.l.

Setup

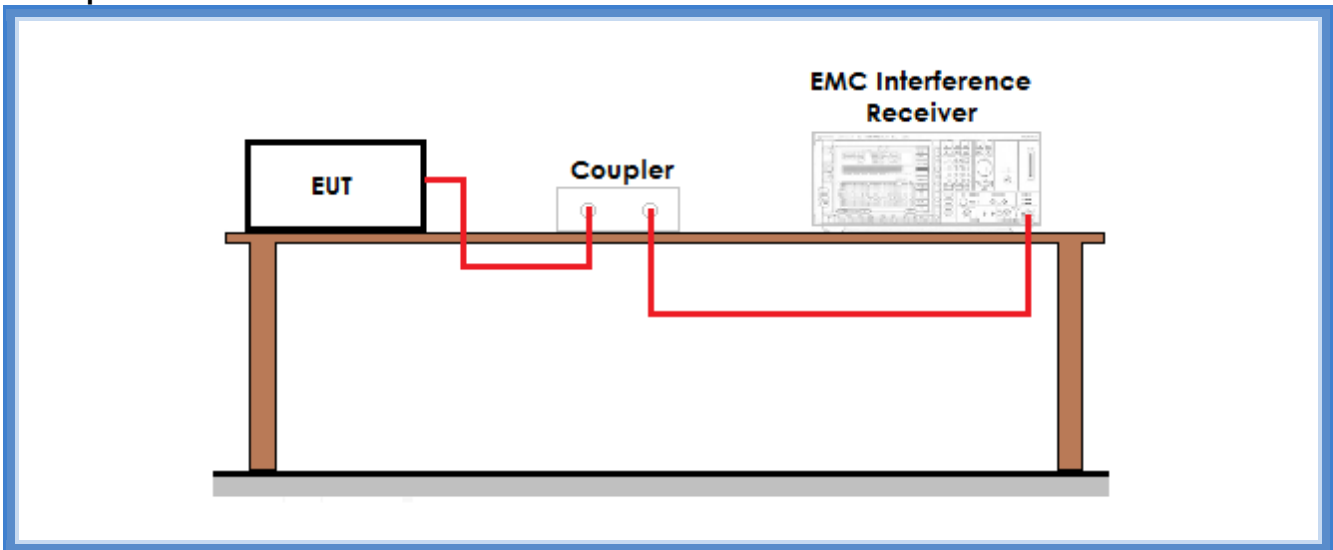

Result

Frequency (MHz)	Graph(s) – Hopping	Results	
915,05	G18168132	F _L : 914,9121 MHz	Complies
	G18168140		
927,80	G18168139	F _H : 927,9381 MHz	Complies

Frequency (MHz)	Graph(s) – No hopping	Results	
915,05	G18168123	F _L : 914,9120 MHz	Complies
	G18168124		
927,80	G18168125	F _H : 927,9391 MHz	Complies



Graphs

Gandini 18168123

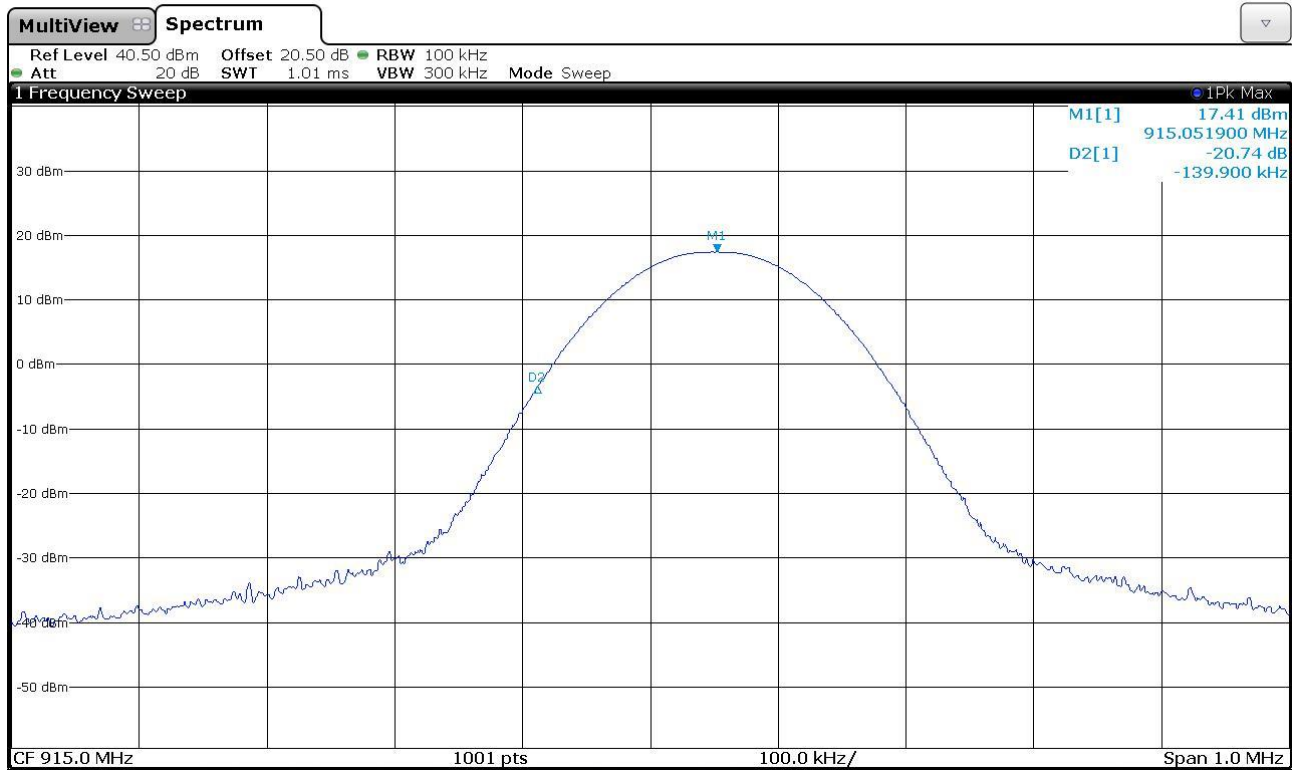



Gandini 18168124





Gandini 18168125

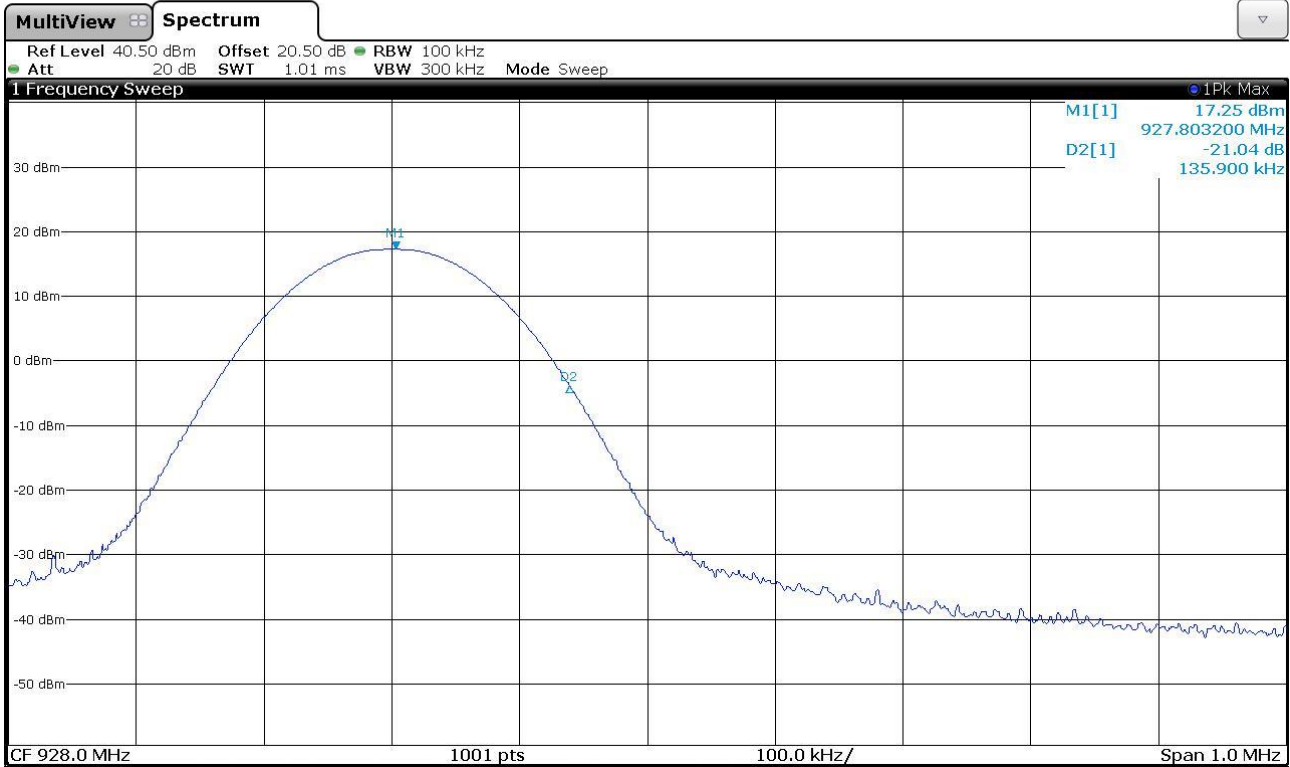



Gandini 18168132

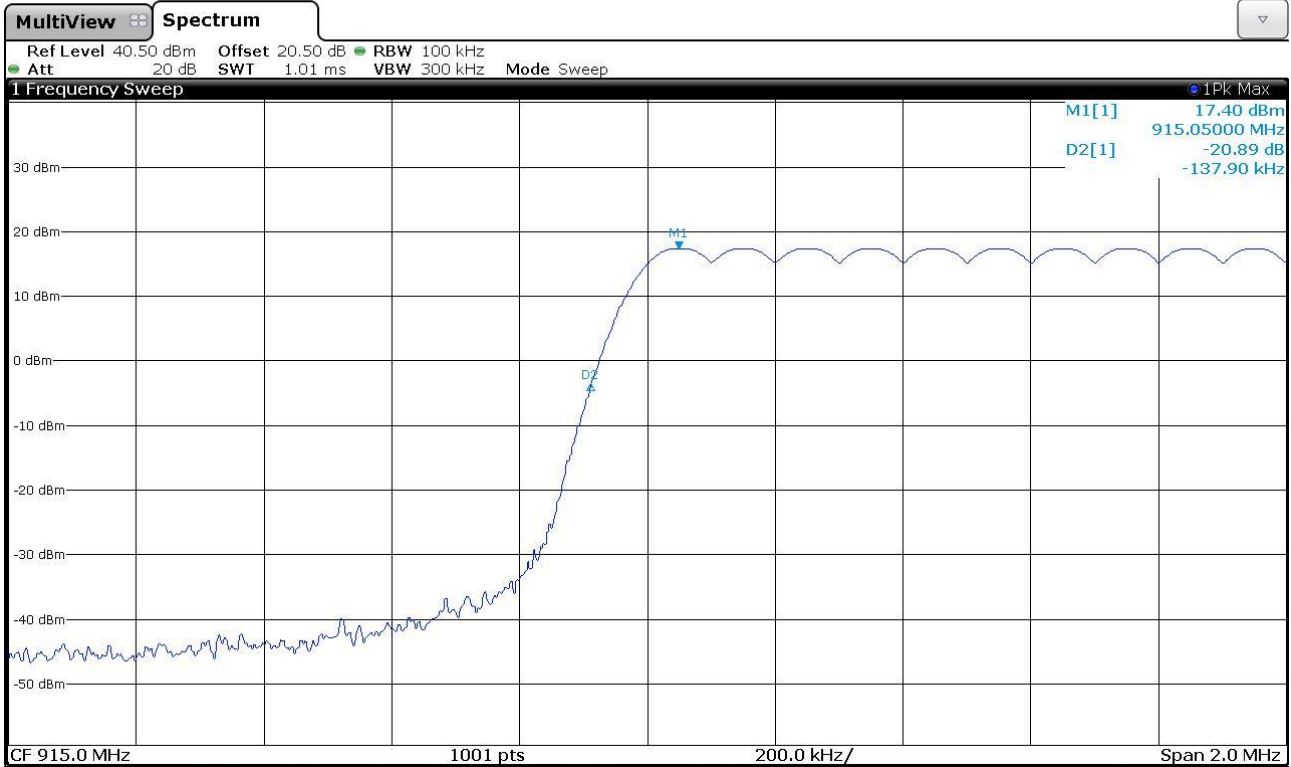



Gandini 18168139

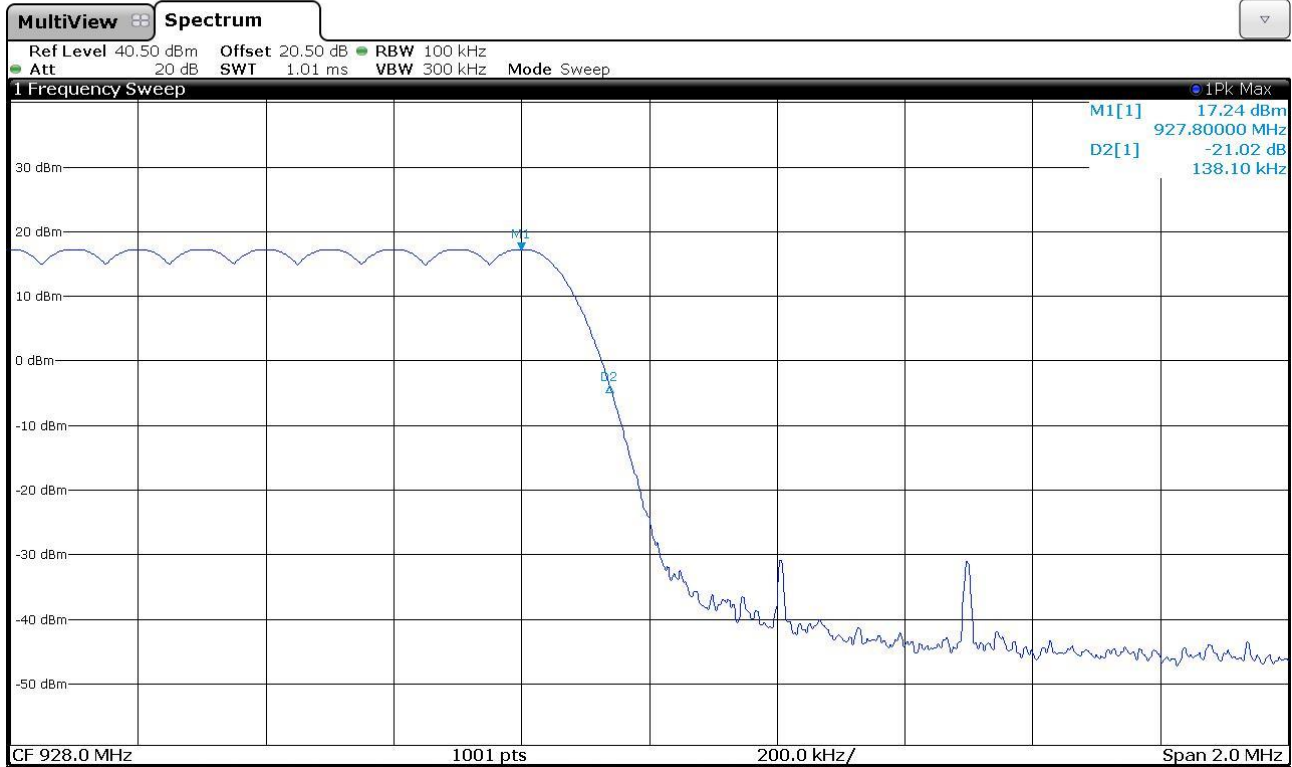

CMC Centro Misure Compatibilità S.r.l.



Gandini 18168140

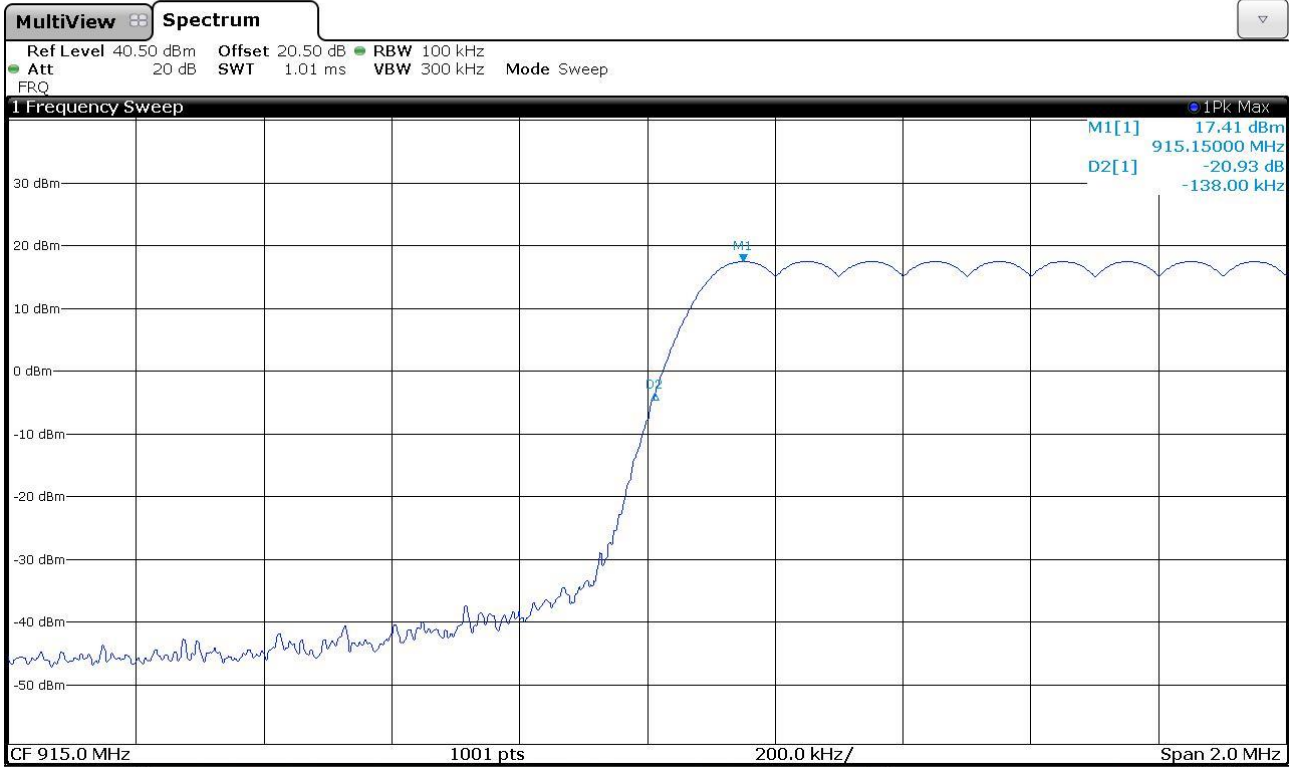

Result: The requirements are met



11.8 Peak Output Power

Test set-up and execution

- FCC Rules and Regulation; Titles 47 Part 15.247
- ANSI C63.10 cl. 7.8.5
- Internal procedure PM001
- See clause 4 of this test report

Test configuration and test method

Test site:
 Laboratory

Auxiliary equipment:
 See clause 4 of this test report

EUT exercising

See clause 4 of this test report

Test equipment used

CMC S295
 Measurement uncertainty: See clause 7 of this test report

Test specification

Port: Antenna

Environmental conditions

<i>Temperature (°C)</i>	<i>Atmospheric pressure (kPa)</i>	<i>Relative humidity (%)</i>
20	100	45

For frequency hopping systems operating in the 2400–2483,5 MHz band employing at least 75 non-overlapping hopping channels, and all frequency hopping systems in the 5725–5850 MHz band: 1 watt. For all other frequency hopping systems in the 2400–2483,5 MHz band: 0,125 watts. For frequency hopping systems operating in the 902–928 MHz band: 1 watt for systems employing at least 50 hopping channels; and, 0,25 watts for systems employing less than 50 hopping channels, but at least 25 hopping channels.

Setup

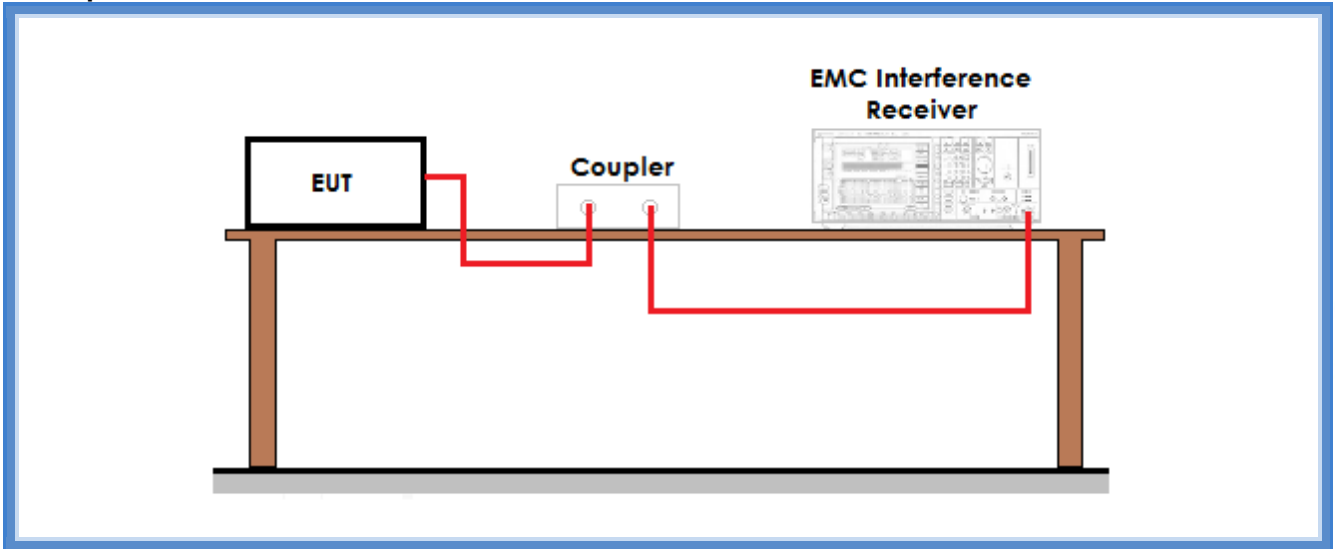

Result

Frequency (MHz)	Graphs	Conducted measured level (dBm)	Conducted power level (mW)	Calculated radiated level (dB μ V/m)
915,048881	G18168122	17,41	55,08	112,64
921,397443	G18168131	17,32	53,95	112,55
927,798002	G18168126	17,25	53,09	112,48



Graphs

Gandini 18168122

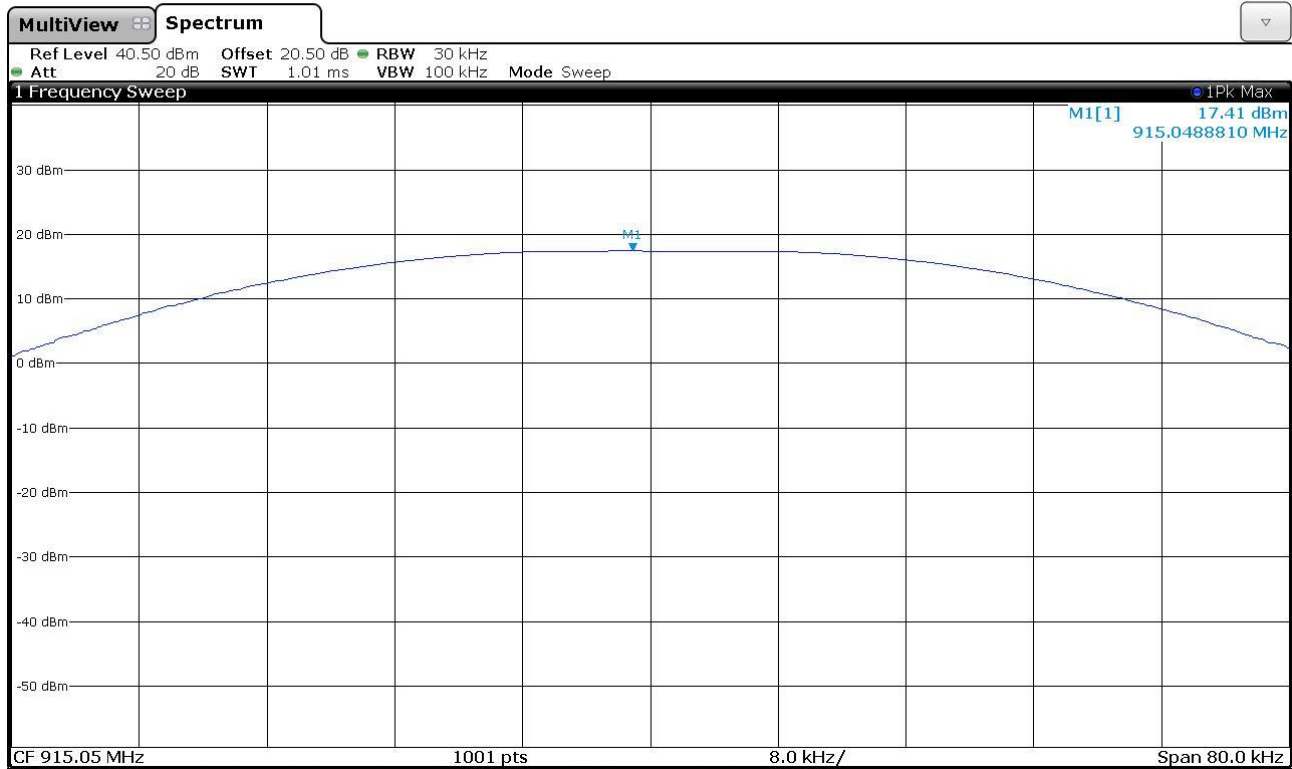

Gandini 18168126

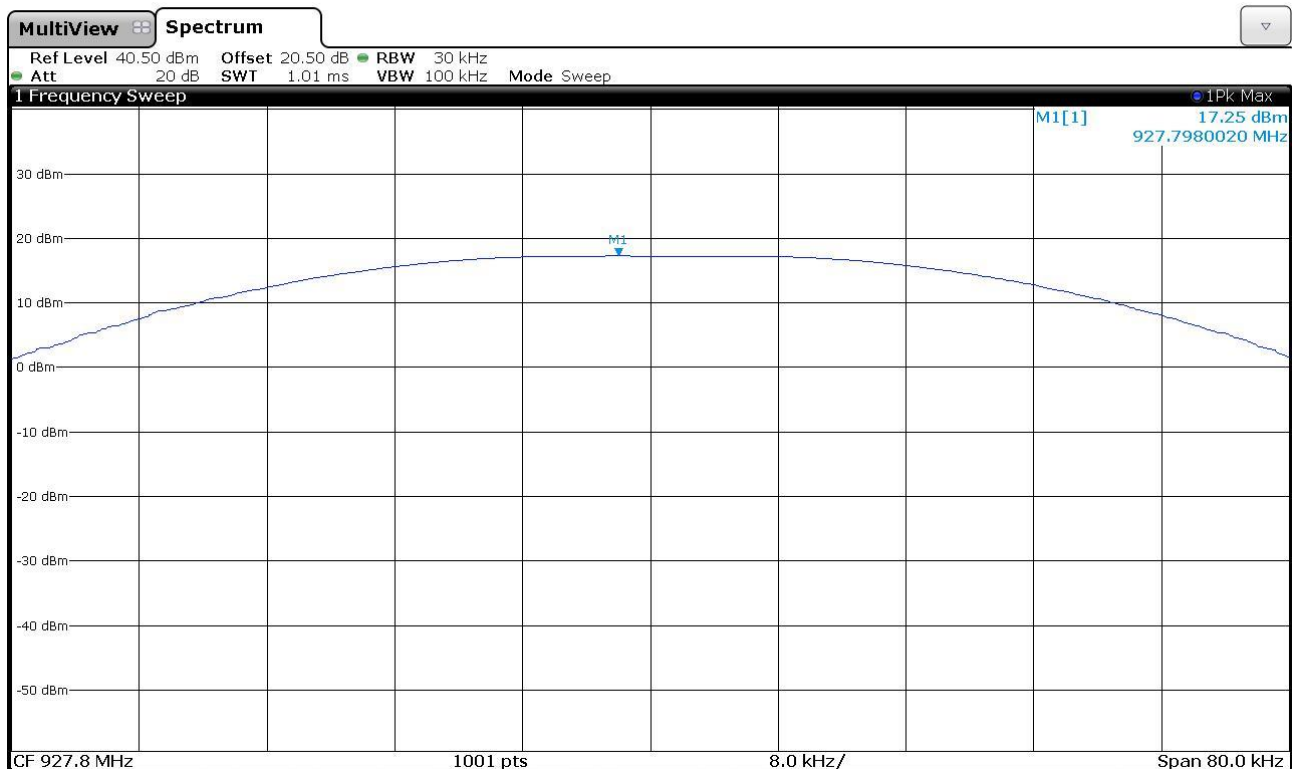



Gandini 18168131

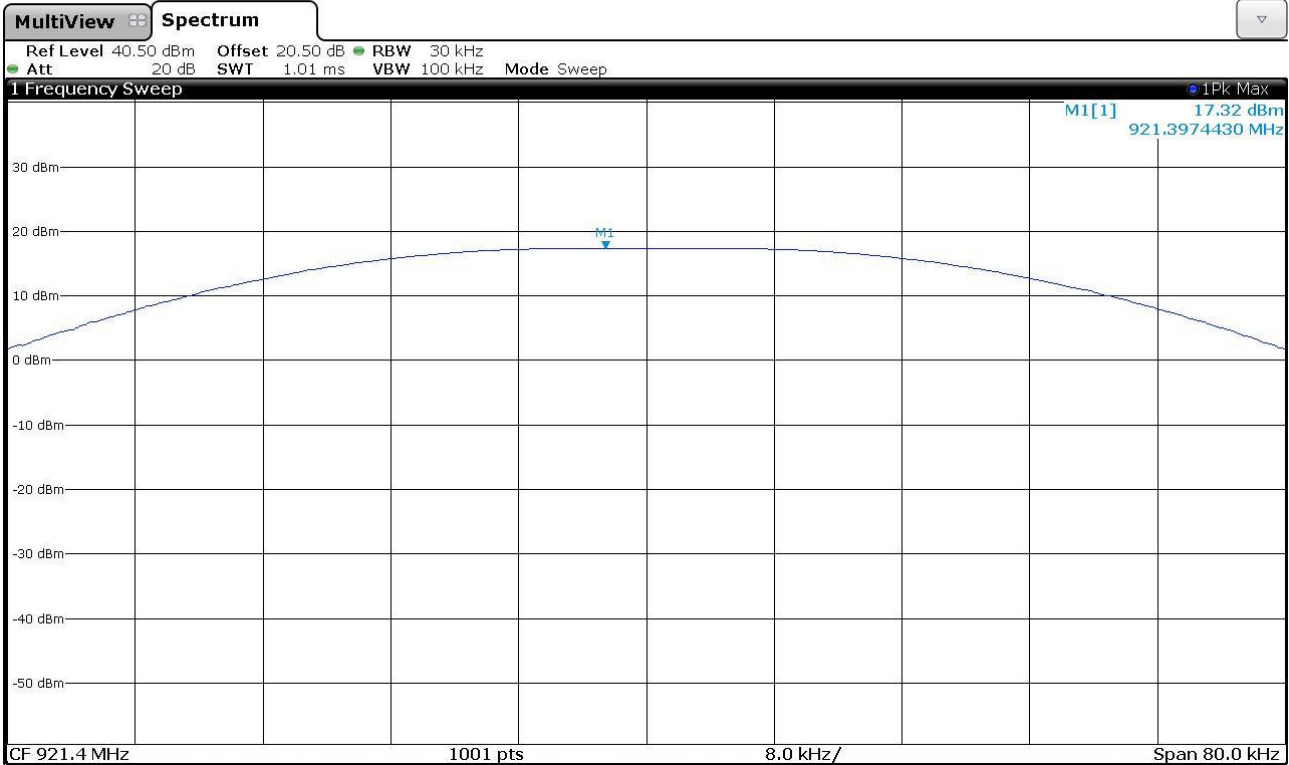

Result: The requirements are met

CMC Centro Misure Compatibilità S.r.l.



11.9 Spurious Emission

Test set-up and execution

- FCC Rules and Regulation; Titles 47 Part 15.209
- Internal procedure PM001
- See clause 4 of this test report

Test configuration and test method

Test site:
Semi-anechoic chamber

Auxiliary equipment:
See clause 4 of this test report

EUT exercising

See clause 4 of this test report

Test equipment used

CMC S108, CMC S136, CMC S164
Measurement uncertainty: See clause 7 of this test report

Test specification

Port: Enclosure
Frequency range: 0,009 MHz – 10000 MHz
Antenna polarization: Horizontal (H) – Vertical (V)
10 m for frequencies \leq 30 MHz
3 m for frequencies $>$ 30 MHz

Environmental conditions

Temperature (°C)	Atmospheric pressure (kPa)	Relative humidity (%)
22	100	45

Acceptance limits

Acceptance limits for emissions in restricted frequency bands		
Frequency (MHz)	AV limits [dB(μ V/m)]	Peak limits [dB(μ V/m)]
$>$ 1000	54	74



The restricted frequency bands are listed in the following table

MHz	MHz	MHz	GHz
0,090 – 0,110	16,42 – 16,423	399,9 – 410	4,5 – 5,15
0,495 – 0,505	16,69475 – 16,69525	608 – 614	5,35 – 5,46
2,1735 – 2,1905	16,80425 – 16,80475	960 – 1240	7,25 – 7,75
4,125 – 4,128	25,5 – 25,67	1300 – 1427	8,025 – 8,5
4,17725 – 4,17775	37,5 – 38,25	1435 – 1626,5	9,0 – 9,2
4,20725 – 4,20775	73 – 74,6	1645,5 – 1646,5	9,3 – 9,5
6,215 – 6,218	74,8 – 75,2	1660 – 1710	10,6 – 12,7
6,26775 – 6,26825	108 – 121,94	1718,8 – 1722,2	13,25 – 13,4
6,31175 – 6,31225	123 – 138	2200 – 2300	14,47 – 14,5
8,291 – 8,294	149,9 – 150,05	2310 – 2390	15,35 – 16,2
8,362 – 8,366	156,52475 – 156,52525	2483,5 – 2500	17,7 – 21,4
8,37625 – 8,38675	156,7 – 156,9	2690 – 2900	22,01 – 23,12
8,41425 – 8,41475	162,0125 – 167,17	3260 – 3267	23,6 – 24,0
12,29 – 12,293	167,72 – 173,2	3332 – 3339	31,2 – 31,8
12,51975 – 12,52025	240 – 285	3345,8 – 3358	36,43 – 36,5
12,57675 – 12,57725	322 – 335,4	3600 – 4400	Above 38,6
13,36 – 13,41			

Acceptance limits for emissions in non-restricted frequency bands

In any 100 kHz bandwidth outside the frequency band in which the spread spectrum or digitally modulated intentional radiator is operating, the radio frequency power that is produced by the intentional radiator shall be at least 20 dB below that in the 100 kHz bandwidth within the band that contains the highest level of the desired power, based on either an RF conducted or a radiated measurement, provided the transmitter demonstrates compliance with the peak conducted power limits.



Setup

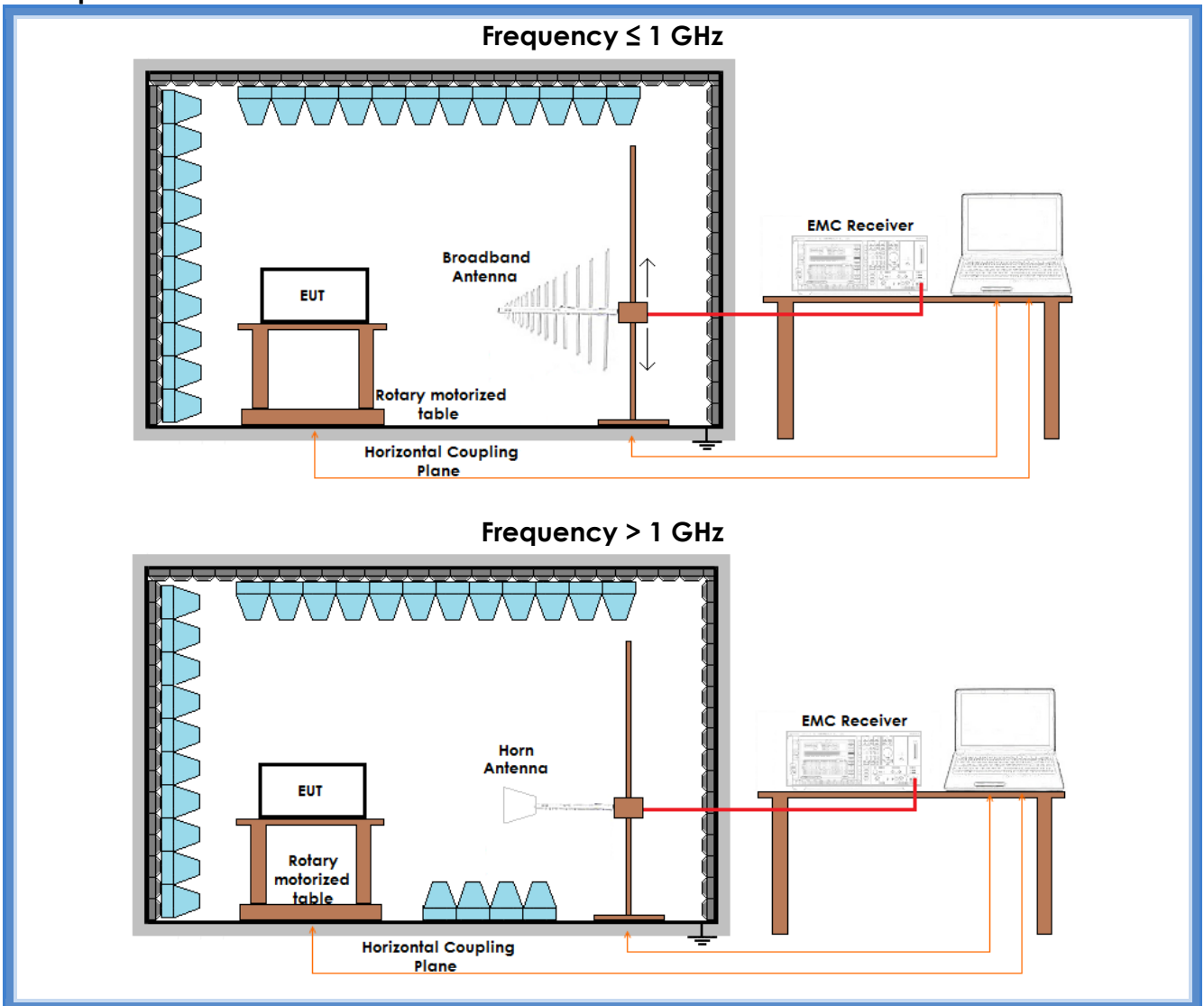



Result – AV detector

Harmonic	Lowest channel		Medium channel		Highest channel		Results
	Level (dB μ V/m)	Limits (dB μ V/m)	Level (dB μ V/m)	Limits (dB μ V/m)	Level (dB μ V/m)	Limits (dB μ V/m)	
II	45,25	54,00	45,20	54,00	42,90	54,00	Complies
III	More than 20 dB below limit	54,00	More than 20 dB below limit	54,00	More than 20 dB below limit	54,00	Complies
IV	41,10	54,00	More than 20 dB below limit	54,00	More than 20 dB below limit	54,00	Complies
V	45,49	54,00	40,54	54,00	39,54	54,00	Complies
VI	42,94	54,00	45,17	54,00	43,88	54,00	Complies
VII	More than 20 dB below limit	54,00	More than 20 dB below limit	54,00	42,64	54,00	Complies
VIII	More than 20 dB below limit	54,00	More than 20 dB below limit	54,00	More than 20 dB below limit	54,00	Complies
IX	More than 20 dB below limit	54,00	More than 20 dB below limit	54,00	More than 20 dB below limit	54,00	Complies
X	More than 20 dB below limit	54,00	More than 20 dB below limit	54,00	More than 20 dB below limit	54,00	Complies

Remarks: EUT was tested in 3 orthogonal planes. The results in this table show the highest values. No spurious other than harmonics have been found. The results have been extrapolated to the specified distance using an extrapolation factor. For all harmonics it was considered the limit of 54 dB μ V/m as a worse case.



Result – Peak detector

Harmonic	Lowest channel		Medium channel		Highest channel		Results
	Level (dB μ V/m)	Limits (dB μ V/m)	Level (dB μ V/m)	Limits (dB μ V/m)	Level (dB μ V/m)	Limits (dB μ V/m)	
II	49,13	74,00	48,64	74,00	47,47	74,00	Complies
III	More than 20 dB below limit	74,00	53,87	74,00	More than 20 dB below limit	74,00	Complies
IV	50,40	74,00	More than 20 dB below limit	74,00	More than 20 dB below limit	74,00	Complies
V	52,69	74,00	49,83	74,00	50,32	74,00	Complies
VI	53,44	74,00	52,43	74,00	52,47	74,00	Complies
VII	More than 20 dB below limit	74,00	More than 20 dB below limit	74,00	More than 20 dB below limit	74,00	Complies
VIII	More than 20 dB below limit	74,00	More than 20 dB below limit	74,00	More than 20 dB below limit	74,00	Complies
IX	More than 20 dB below limit	74,00	More than 20 dB below limit	74,00	More than 20 dB below limit	74,00	Complies
X	More than 20 dB below limit	74,00	More than 20 dB below limit	74,00	More than 20 dB below limit	74,00	Complies

Remarks: EUT was tested in 3 orthogonal planes. The results in this table show the highest values. No spurious other than harmonics have been found. The results have been extrapolated to the specified distance using an extrapolation factor. For all harmonics it was considered the limit of 74 dB μ V/m as a worse case.

Result: The requirements are met