

DYNAMIC SERIES

Part D: ARM receiving unit



INDEX

1	Description	D - 2
3	Technical data sheet	D - 3
4	Plates	D - 4
5	Light signals	D - 4
6	Values of proportional outputs	D - 7
7	Data memory backup	D - 10
8	Malfunction signalled by the receiving unit	D - 11

1 Description

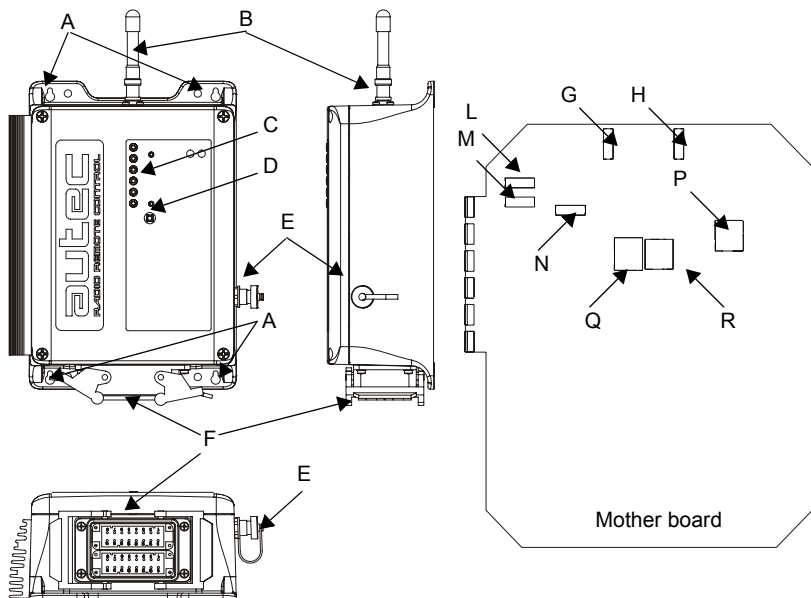

A	mounting holes	G	fuse F1
B	antenna	H	fuse F2
C	LEDs	L	fuse F3
D	TEACH pushbutton	M	fuse F4
E	connector for cable control	N	fuse F5
F	plug	P	DTK connector (for data memory)
		Q	IDK (for address key)
		R	BKK connector (for backup data memory)

The receiving unit communicates with the machine through the outputs and their wiring and/or through a CAN network (of which it is a slave node). The STOP (STP_1 and STP_2) and SAFETY (SAF_1 and SAF_2) outputs are some of the receiving unit's outputs.

2 Technical data

Power supply	8-30 V $\overline{=}$
Antenna	dedicated
Rated current of outputs STOP_1 and STOP_2	7.5 A (30 V $\overline{=}$)
Rated current of output SAF_1	7.5 A (30 V $\overline{=}$)
Rated current of output SAF_2	3 A (30 V $\overline{=}$)
Rated current of digital outputs	4 A (30 V $\overline{=}$)
Rated current of analogue outputs (PWM)	2 A (30 V $\overline{=}$)
Rated current of analogue outputs (voltage)	10 mA (28 V $\overline{=}$)
Protection SAF_2 (fuse F1)	3 A (32 V $\overline{=}$, autofuse)
Protection of power supply (fuse F2)	7.5 A (32 V $\overline{=}$, autofuse)
Protection STOP_1 (fuse F3)	7.5 A (32 V $\overline{=}$, autofuse)
Protection STOP_2 (fuse F4)	7.5 A (32 V $\overline{=}$, autofuse)
Protection SAF_1 (fuse F5)	7.5 A (32 V $\overline{=}$, autofuse)
Housing material	PA6 (20% fg)
Protection degree	IP65 (NEMA 4)
Dimensions	200 x 230 x 95 mm (7.9 x 9.1 x 3.8 In)
Weight	3 kg (6.6 Lb)

3 Technical data sheet

The technical data sheet contains the wiring diagram showing the connection between the receiving unit and the machine.

It also contains the transmitting unit configuration and shows the matching between commands sent and machine functions/movements.

The technical data sheet must be filled in, checked and signed by the installer, who is responsible for a correct wiring.

The technical data sheet must be kept together with this manual (always keep a copy of this data sheet for administrative purposes).



The wiring of the receiving unit outputs must always reflect the wiring indicated in the technical data sheet.

4 Plates

The receiving unit has two plates.

Plate	Position	Content
radio remote control identification plate	On the cover of the receiving unit	Radio remote control serial number, bar code (S/N) and manufacturing year.
technical data plate	On the cover of the receiving unit	MODEL, TYPE and main receiving unit technical data, marking and possible radio remote control marks.

5 Light signals

The ARM receiving unit has six LEDs:

- POWER is green
- ALARM is red
- STATUS is blue
- RUN is green
- ERR is red
- SETUP is yellow.



1. POWER LED (green)

The POWER LED indicates the status of the receiving unit and of the radio link.

The POWER LED ...	Meaning
... is off	The receiving unit is switched off.
...blinks	Radio link has been built.
... is on	No radio link.

2. ALARM LED (red)

The ALARM LED warns about anomalies in the receiving unit.

The ALARM LED ...	Meaning
... is off	The receiving unit works correctly.
... blinks once	Error on the STOP outputs.
... blinks twice	Error on the SAFETY outputs.
... blinks three times	Error on the outputs corresponding to direction commands.
... is on	The receiving unit does not work correctly.

3. STATUS LED (blue)

The STATUS LED warns about anomalies on the outputs or on the power supply and indicates the reception of data from the transmitting unit.

The STATUS LED ...	Meaning
... is off	No radio link.
... blinks slowly	Over-voltage on power supply.
... blinks fast	The receiving unit receives data from the transmitting unit.
... is on	Over-current in one of the PWM analogue outputs.

4. RUN LED (green)

The RUN LED indicates the status of the communication between the receiving unit and the CAN network Master node.

The RUN LED ...	Meaning
... is off	The receiving unit does not work as a CAN network node.
...blinks	The receiving unit does not send commands in the CAN network.
... is on	The receiving unit is working correctly as a node in the CAN network.

RUN LED signals reflect the guidelines of the CANopen®, standard, CiA recommendation 303-3.

5. ERR LED (red)

The ERR LED indicates the status of the CAN communication.

The ERR LED ...	Meaning
... is off	The CAN communication is working correctly.
...blinks	The CAN communication does not work correctly.
... is on	No CAN communication.

ERR LED signals reflect the guidelines of the CANopen® standard (CiA recommendation 303-3).

6. SETUP LED (yellow)

The SETUP LED shows the status of the data memory and of the address key, depending on the receiving unit's working status.

The SETUP LED ...	Meaning
... is off	The receiving unit works correctly.
... blinks once	Error on the address key.
... blinks twice	Error on the data memory.
... blinks slowly three times	Calibration of the rest position values for proportional outputs (see paragraph 6.2) or the procedure "Copy data memory" (see chapter 7) is being performed.
... blinks quickly three times	The receiving unit is saving data set with the REMOTE SETUP procedure (see chapter 6).
... blinks four times	Inversion of movement direction of the joysticks axis is being performed (see paragraph 6.3).
... blinks slowly	A data memory is connected to the BKK connector.
... blinks fast	This signal has two meanings, depending on the current working status: <ul style="list-style-type: none"> - the receiving unit is restoring factory settings (see paragraph 6.4) - an error occurred during the "Data memory backup" (see chapter 7).
... is on	Calibration of maximum and minimum values of proportional outputs is being performed (see paragraph 6.1).

6 Values of proportional outputs

Proportional outputs in the ARS receiving unit are factory set: values are given in the technical data sheet.

The REMOTE SETUP procedure is used to modify:

- maximum and minimum values of proportional outputs (see paragraph 6.1),
- values related to the rest position of proportional outputs (offset) (see paragraph 6.2),
- direction of movements of joystick's axis (see paragraph 6.3).



WARNING

The REMOTE SETUP procedure can only be performed by skilled and properly trained personnel.



WARNING

During the REMOTE SETUP procedure, pay particular attention to the machine behaviour, as it moves as a response to acting on the actuators.

It is possible to restore factory settings at any time, if necessary (see paragraph 6.4).

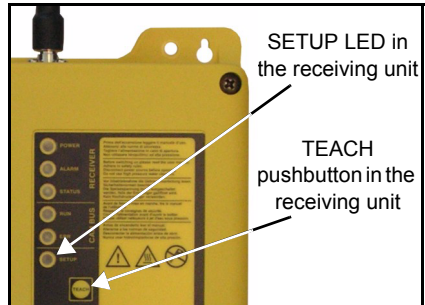

6.1 Calibrating maximum and minimum values of proportional outputs

1. Start up the radio remote control.
2. Press the TEACH pushbutton in the receiving unit and do not release it until the SETUP LED illuminates.
3. Set the desired values as follows:
 - To set the maximum value, move the joystick to the maximum range of the semi-axis to be calibrated. Maintain the position and use the TEACH selector on the transmitting unit to set the desired value.
 - To set the minimum value, move the joystick slightly out of the rest position of the semi-axis to be calibrated. Maintain the position and use the TEACH selector on the transmitting unit to set the desired value.
 - After calibrating one joystick, press the STOP pushbutton to save calibrations. Calibrations are saved in the data memory on the DTK connector.
 - To set other values, unlock the STOP pushbutton, press the START pushbutton and repeat actions described in point 3..
4. To leave the procedure, press the TEACH pushbutton on the receiving unit and do not release it until the SETUP LED switches off.



If the proportional outputs are activated by actuators that are not joysticks (i.e. potentiometer, switch), calibrate maximum and minimum values according to the abovementioned procedure.



If a speed selector is present on the transmitting unit, minimum and maximum values have to be calibrated for each of the selector positions.



If inputs are used in the receiving unit to select different speeds, calibration must be performed while these inputs are active.

CAUTION

6.2 Calibrating values related to the rest position of proportional outputs (offset)

1. Start up the radio remote control.
2. Press the TEACH pushbutton in the receiving unit and do not release it until the SETUP LED illuminates.
3. Activate and release the “TEACH +” command related to the corresponding switch on the transmitting unit.
4. Press and release the START pushbutton.
5. Repeat actions described in points 3. and 4. until the SETUP LED on the receiving unit starts blinking three times.
6. Set the desired values as follows:
 - Move the joystick out of the rest position of the axis to be calibrated. Maintain the position and use the TEACH selector on the transmitting unit to set the desired value.
 - After calibrating one joystick, press the STOP pushbutton to save calibrations. Calibrations are saved in the data memory on the DTK connector.
 - To set other values, unlock the STOP pushbutton, press the START pushbutton and repeat actions described in point 6..
7. To leave the procedure, press the TEACH pushbutton on the receiving unit and do not release it until the SETUP LED switches off.



If the proportional outputs are activated by actuators that are not joysticks (i.e. potentiometer, switch), calibrate values related to the rest position according to the abovementioned procedure.

6.3 Inversion of movement direction of the joystick's axis

1. Start up the radio remote control.
2. Press the TEACH pushbutton in the receiving unit and do not release it until the SETUP LED illuminates.
3. Activate and release the "TEACH +" command related to the corresponding switch on the transmitting unit.
4. Press and release the START pushbutton.
5. Repeat actions described in points 3. and 4. until the SETUP LED on the receiving unit starts blinking four times.
6. Set the desired values as follows:
 - Move the joystick out of the rest position of the axis to be calibrated. Maintain this position and activate once the "TEACH +" command related to the corresponding switch on the transmitting unit.
 - After calibrating one joystick in the transmitting unit, press the STOP pushbutton to save calibrations. Calibrations are saved in the data memory on the DTK connector.
 - To set other values, unlock the STOP pushbutton, press the START pushbutton and repeat actions described in point 6..
7. To leave the procedure, press the TEACH pushbutton on the receiving unit and do not release it until the SETUP LED switches off.

6.4 Restoring factory settings

This procedure is used to restore factory settings for the proportional outputs.

1. Ensure that the transmitting unit is switched off.
2. Power on the receiving unit.
3. Press the TEACH pushbutton and do not release it until the SETUP LED illuminates.
4. Press the TEACH pushbutton three times and do not release it at last pressure; the SETUP LED blinks fast: this indicates that factory settings are being restored.
5. Release the TEACH pushbutton when the SETUP LED is steadily illuminated again.

If the TEACH pushbutton is released before the SETUP LED is steadily illuminated, factory settings of proportional outputs will not be restored.
6. To leave the procedure, press the TEACH pushbutton on the receiving unit and do not release it until the SETUP LED switches off.

7 Data memory backup

The receiving unit has two data memories: one is in the DTK connector on the mother board and one is attached inside the cover (backup data memory). When data of proportional outputs are modified, they are saved in the data memory present in the DTK connector.

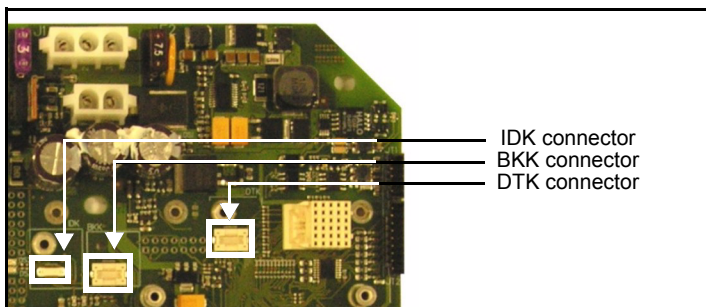

CAUTION

The data memory in the DTK connector can be copied into a backup data memory. This is useful in case you need to restore the information contained. In this case, use the data memory attached inside the cover.



If one of the data memories is lost or damaged, ask the machine manufacturer for a new one.



CAUTION

Please note that information contained in the data memory in the DTK connector overwrites the data memory of the BKK connector during the backup procedure.

Perform the following steps to copy the information of the data memory.

1. Make sure that the transmitting unit and the receiving unit are not powered.
2. Open the receiving unit
3. Make sure that a data memory is plugged in the DTK connector
4. Insert the memory attached inside the receiving unit cover in the BKK connector
5. Close the receiving unit
6. Power on the receiving unit: the SETUP LED blinks slowly
7. Press the TEACH pushbutton: the SETUP LED blinks fast (indicating that data are being copied); release the button when the LED starts blinking slowly again.

If the TEACH pushbutton is released before the SETUP LED starts blinking slowly again, data contained in the data memory will not be copied.

8. Remove power from the receiving unit.
9. Open the receiving unit, remove the data memory from the BKK connector and attach it inside the cover.

10. Close the receiving unit.

8 Malfunction signalled by the receiving unit

Use the light signals on the receiving unit to identify the radio remote control malfunction.

If the problem persists after the suggested solution has been carried out, contact the support service of the machine manufacturer.

Signals	Possible reason	Solutions
The POWER LED is off.	The receiving unit is switched off.	Make sure that fuse F2 is intact. Correctly plug in the connecting plug and power on the receiving unit.
The POWER LED is on.	No radio link.	Bring the transmitting unit close to the receiving unit.
The ALARM LED blinks once.	Error on the STOP outputs.	Make sure that fuses F3 and F4 are intact. Correctly plug in the connecting plug. Make sure that the STOP outputs are wired correctly.
The ALARM LED blinks twice.	Error on the SAFETY outputs.	Make sure that fuses F1 and F5 are intact. Correctly plug in the connecting plug. Make sure that the SAFETY outputs are wired correctly.
The ALARM LED blinks three times.	Error on the outputs corresponding to direction commands.	Contact the support service of the machine manufacturer. Make sure that the outputs of direction commands are wired correctly.
The ALARM LED is on.	The receiving unit does not work correctly.	Contact the support service of the machine manufacturer.
The STATUS LED blinks slowly.	Over-voltage on power supply.	Make sure that the receiving unit power supply is within the voltage limits provided in the technical data.
The STATUS LED blinks fast and irregularly.	The receiving unit loses some data sent by the transmitting unit.	Bring the transmitting unit close to the receiving unit. If this signal persists, contact the support service of the machine manufacturer.

Signals	Possible reason	Solutions
The STATUS LED is on.	Over-current in one of the PWM analogue outputs.	Contact the support service of the machine manufacturer.
The RUN LED blinks.	The receiving unit does not send commands in the CAN network.	Contact the support service of the machine manufacturer.
The ERR LED blinks.	CAN communication error.	Contact the support service of the machine manufacturer.
The SETUP LED blinks once.	Error on the address key.	Contact the support service of the machine manufacturer.
The SETUP LED blinks twice.	Error on the data memory.	Replace the data memory on the DTK connector with the backup data memory attached inside the cover (see chapter 7).
The SETUP LED blinks slowly.	A data memory is connected to the BKK connector.	If you are not performing a backup of the data memory, remove the memory from the BKK connector (see chapter 7).