

AIR SERIES

Part C: AJR transmitting unit

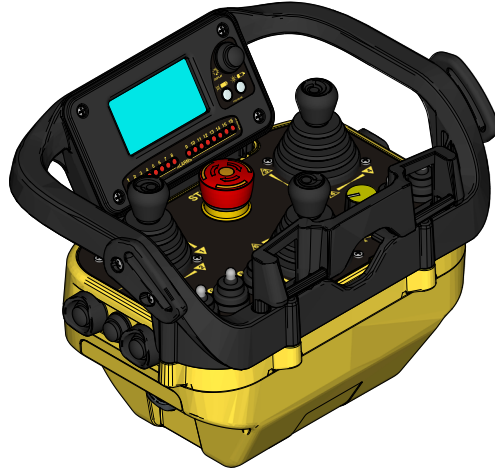

INDEX

1	Description	2
2	Technical data	3
3	Technical data sheet	3
4	Plates	4
4.1	Plates on AJR unit in a radio remote control	4
4.2	Plates on AJR unit in a Take & Release system	4
4.3	Plates on AJR unit in a Multi Units or Multi Receiver system	5
5	Light signals	6
6	General operating instructions	7
6.1	Starting up the radio remote control	7
6.2	Command activation	8
6.3	Data Feedback Function	8
6.4	Radio link interruption	9
6.5	Transmitting unit automatic switch off	9
6.6	Switching off the transmitting unit	9
7	Operation	10
7.1	Battery	10
7.2	Air-KEY	11
7.3	START pushbutton	12
7.4	STOP pushbutton	12
7.5	DISPLAY pushbutton (if the transmitting unit has a display)	13
8	Malfunction signalled by the transmitting unit	14

1 Description

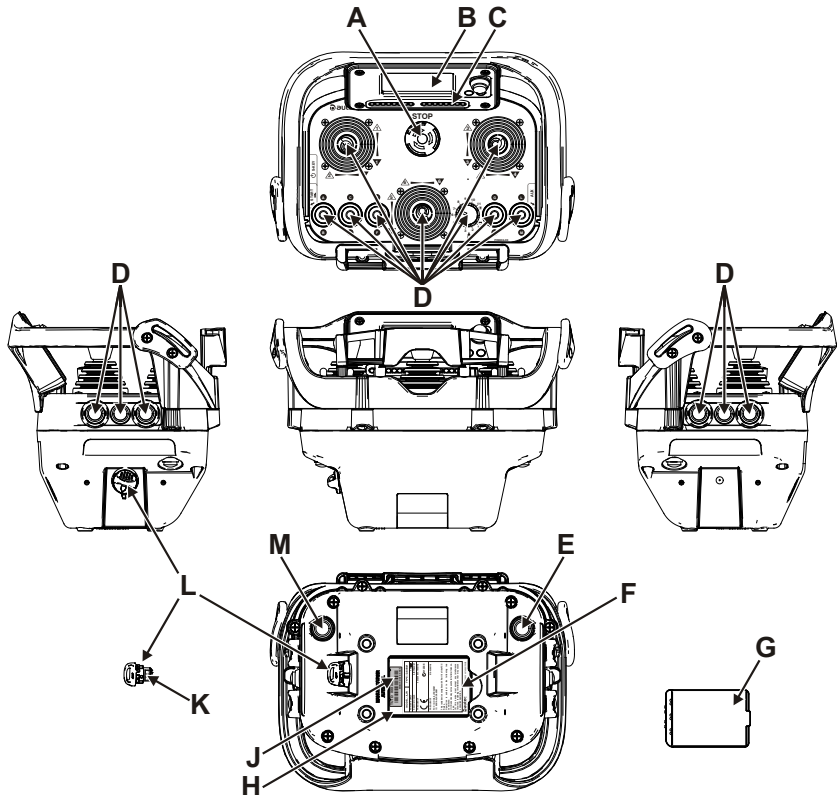

A	STOP pushbutton
B	Display or LED (if present)
C	LEDs
D	Actuators (joysticks, selectors, pushbuttons)
E	FUNCTION pushbutton
F	Technical data plate
G	Battery

H	Battery housing
J	Transmitting unit identification plate
K	Identification plate of the radio remote control or system
L	Air-KEY (electronic starting key)
M	START pushbutton

2 Technical data

Power supply (battery LPM02)	Li-Ion 7.4V==
Power supply (battery MBM06MH)	NiMH 7.2V==
Antenna	internal
Housing material	PA 6 (20%fg)
Protection degree	IP65 (NEMA 4)
Dimensions	260x200x190mm (10.2x7.9x7.5In)
Weight	2.0kg (4.4Lb)
Run time at 20°C (68°F):	
- with battery LPM02	40h
- with battery LPM02 and Data Feedback function.....	20h
- with battery MBM06MH	20h
- with battery MBM06MH and Data Feedback function	10h

3 Technical data sheet

The technical data sheet contains the transmitting unit configuration and shows the matching between commands sent and machine functions/movements. It also contains the wiring diagram showing the connection between the receiving unit and the machine.

Each technical data sheet must be filled in, checked and signed by the installer, who is responsible for a correct wiring.

A copy of the technical data sheet must always be kept together with this manual (always keep a copy of this data sheet for administrative purposes).

 WARNING	<p>The wiring of the receiving unit outputs must always reflect the wiring indicated in the technical data sheet.</p>
--	--

4 Plates

4.1 Plates on AJR unit in a radio remote control

Plate	Position	Content
radio remote control identification plate	On the Air-KEY: remove the Air-KEY to read the plate.	Radio remote control serial number (S/N).
transmitting unit identification plate	In the battery housing: remove the battery to read the plate.	Manufacturing year, bar code and transmitting unit identification number (TU ID).
technical data plate	In the battery housing: remove the battery to read the plate.	MODEL, TYPE and main transmitting unit technical data, marking and possible radio remote control marks.

4.2 Plates on AJR unit in a Take & Release system

Plate	Position	Content
system identification plate	On the Air-KEY: remove the Air-KEY to read the plate.	System serial number (S/N).
transmitting unit identification plate	In the battery housing: remove the battery to read the plate.	Manufacturing year, bar code and transmitting unit identification number (TU ID).
technical data plate	In the battery housing: remove the battery to read the plate.	MODEL, TYPE and main transmitting unit technical data, marking and possible system marks.

4.3 Plates on AJR unit in a Multi Units or Multi Receiver system

Plate	Position	Content
system identification plate	On the Air-KEY: remove the Air-KEY to read the plate.	System serial number (MULTI S/N).
transmitting unit identification plate	In the battery housing: remove the battery to read the plate.	Manufacturing year, bar code and transmitting unit identification number (TU ID).
technical data plate	In the battery housing: remove the battery to read the plate.	MODEL, TYPE and main transmitting unit technical data, marking and possible system marks.

5 Light signals

In AJR transmitting units, a green and a red LED are always available, providing information regarding the radio remote control.

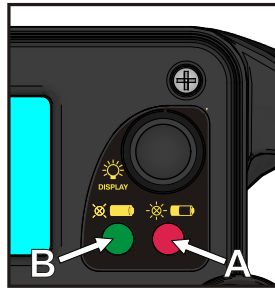
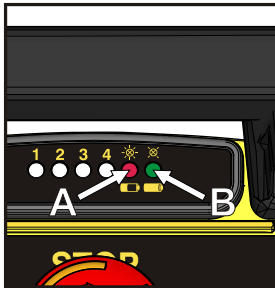

A	Red LED
B	Green LED

The green LED...	Meaning
...is off.	The transmitting unit is switched off.
... is steady on.	The transmitting and receiving unit do not communicate.
... blinks fast.	The transmitting and receiving unit communicate. It is possible to start the radio remote control by pressing the START pushbutton.
... blinks slowly (one blink per second).	It is possible to send commands.

The red LED ...	Meaning
...is off.	The transmitting unit works correctly.
... is steady on.	At start-up, the STOP pushbutton is activated or damaged.
... blinks twice per second.	At least one of the commands that were checked at start-up (see technical data sheet) is enabled or damaged.
... blinks three times per second.	At start-up, the battery is flat.
... is steady on for 2s.	The transmitting unit does not work correctly.
... blinks slowly (one blink per second).	The battery has a 2h run time.
... blinks fast.	The battery has a 10min run time.

For other LED signals, see Data Feedback function (paragraph 6.3).

6 General operating instructions

Starting up the radio remote control consists in building a radio link between the transmitting and the receiving unit.

6.1 Starting up the radio remote control

	<p>As required by standard IEC 60204-32, the radio remote control start up is protected in order to prevent unauthorised use of the machine.</p> <p>A removable key called Air-KEY guarantees such protection. The radio remote control cannot work without it.</p> <p>If the risk assessment requires further protection of the radio remote control start up, the PIN CODE may be activated.</p>
---	---

6.1.1 Start up through Air-KEY (factory setting)

When the receiving unit is powered on, perform the following procedure:

1. Insert a charged battery in the transmitting unit (see paragraph 7.1.1)
2. insert the Air-KEY in the transmitting unit (see paragraph 7.2.1)
3. press the START pushbutton until the green LED blinks slowly.

6.1.2 Start up through Air-KEY and PIN CODE

The PIN CODE provides further protection against unauthorized use of the radio remote control. It consists of a sequence of commands to be carried out by activating the corresponding actuators during start-up. The radio remote control will start up only with the correct sequence. The procedure to enable and modify a PIN CODE is provided in the document “Menu of Transmitting Unit (MTU)”; you can find this document in the dedicated section on Autec’s website.

When the receiving unit is powered on, perform the following procedure:

1. Insert a charged battery in the transmitting unit (see paragraph 7.1.1)
2. insert the Air-KEY in the transmitting unit (see paragraph 7.2.1).

	<p>Consider that the transmitting unit will switch off if more than 3 seconds have passed between the activation of an actuator and the following one.</p>
--	--

3. press the START pushbutton until the green LED illuminates
4. activate the commands corresponding to PIN CODE in the correct sequence (PIN 1, PIN 2 and PIN 3 given in the technical data sheet).
 - a. PIN 1 shall not be included in the start up procedure if it coincides with the START command.
 - b. PIN 3 shall not be included in the start up procedure if it coincides with the START command.
5. press the START pushbutton until the green LED blinks slowly.

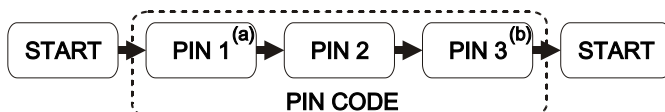

6.2 Command activation

With the radio remote control started, act on the joysticks, pushbuttons and switches corresponding to the command to be performed.

The user must be properly trained about the symbols on the transmitting unit panel, to be aware of the matching between actuators and movements on the machine (symbols used are defined by the machine manufacturer according to the functions of the machine).

6.3 Data Feedback Function

The user receives information and/or signals concerning the controlled machine by means of the Data Feedback function.

During normal radio remote control operation, pay particular attention to the indications displayed and signalled by the display or through the LEDs: they can be helpful to evaluate the machine working status.

	<p>Any information shown and signalled on the display or through the LEDs can never be considered or used as a safety signal or for legal metrology.</p> <p>When operating and moving the machine, remember that the radio remote control does not intervene autonomously when potential hazardous situations are displayed and signalled.</p>
---	--

6.3.1 Operation with display

If the transmitting unit has a display, it is possible to show signal icons, measurements collected from the machine and their description.

Information displayed and how it is displayed (icons and/or measurements and/or descriptions) depend on the settings chosen by the machine manufacturer.

The battery level and the quality of the radio link are also always indicated.

6.3.2 Operation with LED

If the transmitting unit has an LED array, specific machine conditions are signalled if they are on (i.e. load limits, limit switch, ...).

The signalled conditions depend on the settings chosen by the machine manufacturer.

6.4 Radio link interruption

When the radio link is incorrect or interrupted, the receiving unit autonomously stops the radio remote control.

The green LED on the transmitting unit switches from blinking slowly to fast blinking or steady on.

Press the START pushbutton to start the radio remote control.

6.5 Transmitting unit automatic switch off

The transmitting unit automatically switches off when:

- the battery is flat (see paragraph 6.5.1)
- the radio remote control is not used for a certain time (see paragraph 6.5.2)

Press the START pushbutton to start the radio remote control.

6.5.1 Low battery

The transmitting unit indicates if the battery is not sufficiently charged (the red LED blinks fast).

- The red LED blinks slowly (one blink per second): the battery has a 2 hour run time from the first signal.
- the red LED blinks fast: the battery has a 10 minute run time from the first signal, after which the transmitting unit automatically switches off.

The battery needs to be replaced with a charged one (see paragraph 7.1).

6.5.2 When the transmitting unit is not used

If the transmitting units remains started with no enabled commands, it will automatically switch off after a predetermined time frame. This time frame is provided in the technical data sheet (SWITCH-OFF).

Before the transmitting unit switches off automatically, the green and red LEDs blink alternating for 30 seconds.

6.6 Switching off the transmitting unit

The transmitting unit shall be switched off each time work is stopped: remove the Air-KEY (see paragraph 7.2.2) and always store it in a safe place.

7 Operation

7.1 Battery



CAUTION

The Air series' transmitting units can only be powered through Autec rechargeable batteries.

See the battery charger manual enclosed in the packaging with the battery charger for any warnings and instructions regarding the batteries.

7.1.1 Battery insertion

Push the battery towards the contacts on the transmitting unit (1) and insert it inside the housing (2).

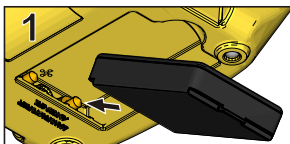

7.1.2 Battery removal

Push the battery towards the contacts on the transmitting unit (3) and remove it from the housing (4).



7.1.3 Battery run time indicator

Perform the following procedure to check the run time of the battery in the transmitting unit:

1. switch off the transmitting unit and unlock the STOP pushbutton
2. activate the S1 command (check in the technical data sheet which actuator it corresponds to) and press the START pushbutton until the LED indicating the battery level illuminates:
 - 1 LED on: low level
 - 2 LEDs on: medium level
 - 3 LEDs on: maximum level.

Run time indication disappears after some seconds.

7.2 Air-KEY

In the transmitting unit, the radio remote control address is stored in the Air-KEY. For this reason, the radio remote control cannot work without this key.



The Air-KEY can only be used in the transmitting unit of the radio remote control where it belongs.

As the radio remote control address is stored in the Air-KEY, use it with utmost care to reduce risks that may result from incorrect handling.

7.2.1 Air-KEY insertion

Perform the following operations to insert the Air-KEY:

1. push the Air-KEY inside the corresponding housing
2. rotate the Air-KEY clockwise.

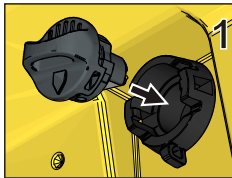

7.2.2 Air-KEY removal

Perform the following operations to insert the Air-KEY:

3. rotate the Air-KEY anticlockwise
4. pull the Air-KEY to remove it from the corresponding housing.

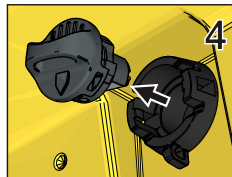

7.2.3 BACK-UP UNIT

If the main transmitting unit cannot be used because it has been lost or damaged, it can be replaced with a transmitting unit called "BACK-UP UNIT".

It is identical to the unit that cannot be used anymore; the only difference is the presence of the plate "BACK-UP UNIT" on the battery housing.



Insert in the "BACK-UP UNIT" the Air-KEY of the transmitting unit that cannot be used any longer and perform the address storage procedure.

Address storage

When the battery is charged and the Air-KEY is in the "BACK-UP UNIT", perform the following procedure to store the address:

1. press the START pushbutton until the green and the red LEDs illuminate and an acoustic signal sounds
2. wait until the green LED blinks slowly
3. within 3 seconds, activate in sequence the commands corresponding to PIN 1, PIN 2 and PIN 3 that compose the PIN code given in the technical data sheet.

If the PIN code is incorrect, the red LED illuminates and the transmitting unit switches off. In this case, the storage procedure shall be repeated.

If the PIN code is correct, the green LED turns steady on and the transmitting unit switches off: this indicates that the address has been stored in the "BACK-UP UNIT". It is now possible to start the radio remote control and control the machine with the "BACK-UP UNIT" transmitting unit.

7.3 START pushbutton

The START pushbutton is used to:

- start the radio remote control (see paragraph 6.1)
- activate the horn when the radio remote control is started.

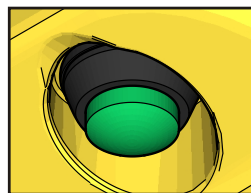

7.4 STOP pushbutton



The STOP pushbutton should be pressed when it is necessary to immediately stop the machine when a dangerous condition occurs.

When the STOP pushbutton is pressed, the machine stops and the transmitting unit switches off.

To start working again after the STOP pushbutton has been pressed:

1. make sure that the working and usage conditions are safe
2. turn the STOP pushbutton in the arrow direction to unlock it
3. start the radio remote control (see paragraph 6.1).



7.5 DISPLAY pushbutton (if the transmitting unit has a display)

This pushbutton is used to:

- activate the display lighting, if it is off
- cyclically scroll the information on the display in two different modes
- manual: the lines scroll up each time the pushbutton is pressed
- automatic: when the DISPLAY pushbutton is pressed for 3 seconds, the lines scroll automatically. If the DISPLAY pushbutton is pressed another time, it switches back to manual mode.

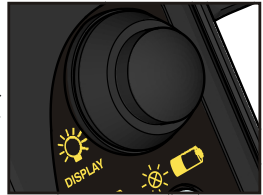

It is not possible to scroll the lines if icons only are displayed.

The display lighting stays on for a time set by the machine manufacturer.

8 Malfunction signalled by the transmitting unit

Use the light signals on the transmitting unit to identify the radio remote control malfunction. If the problem persists after the suggested solution has been carried out, contact the support service of the machine manufacturer.

Signals	Possible reason	Solutions
The green LED is steady on.	The transmitting and receiving unit do not communicate.	Start up the radio remote control. If the radio remote control does not start up, check that the receiving unit is powered on.
The green LED blinks fast.	The radio remote control is not started up.	Bring the actuators corresponding to movement commands to the rest position and press the START pushbutton until the green LED blinks slowly.
The green LED blinks slowly (one blink per second).	The receiving unit may not work correctly.	See "Receiving unit signals" in Part D.
The red LED is steady on during start up	The STOP pushbutton is activated or damaged.	Unlock the STOP pushbutton or contact the support service.
The red LED blinks twice per second during start up.	At least one of the commands that were checked at start-up (see technical data sheet) is enabled or damaged.	Bring the actuators corresponding to the commands checked during start up to the rest position or contact the support service.
The red LED blinks three times per second during start up.	The battery is flat.	Replace the battery with a charged one.
The green and red LEDs are steady on and an acoustic signal sounds during start up.	The Air-KEY was inserted in an incorrect transmitting unit.	Use the correct transmitting unit.
	The transmitting unit has been replaced and the Air-KEY has been inserted in the "BACK-UP UNIT" transmitting unit.	Store the address in the "BACK-UP UNIT" (see paragraph 7.2.3).

Signals	Possible reason	Solutions
The green and red LEDs blink three times per second during start up.	The Air-KEY is damaged.	Contact the support service.
The red LED is steady on for two seconds.	The transmitting unit does not work correctly.	Contact the support service.
The red LED blinks slowly (one blink per second).	The battery has a 2h run time.	Replace the battery with a charged one within 2h.
The red LED blinks quickly.	The battery has a 10min run time.	Bring the system "machine+radio remote control" to a safe state and replace the battery with a charged one.
The green and red LEDs blink alternating	30 s left before the transmitting unit automatically switches off.	Activating any actuator corresponding to a movement command reduces the predetermined automatic switch-off time (SWITCH-OFF) to zero.
The green LED blinks and the red LED is steady on during start up.	The procedure corresponding to the UNPAIR submenu and given in the document "Menu of Transmitting Unit (MTU)" has been carried out.	Contact the support service.

