



FCC PART 15C TEST REPORT FOR CERTIFICATION  
On Behalf of

Sounding Audio Industrial Ltd

Marine Audio System with AM/FM/WB/USB-ipod/Aux in/Bluetooth

Model Number: PA4A

Brand Name: POLK

FCC ID: OPDPA4A

Prepared for : Sounding Audio Industrial Ltd  
Unit N, 7/F, Stage 2. Wah Fung Industrial Centre 33-39  
Kwai Chung Road, Kwai Chung, Hong Kong

Prepared By : Audix Technology (Shenzhen) Co., Ltd.  
No. 6, Ke Feng Rd., 52 Block,  
Shenzhen Science & Industrial Park,  
Nantou, Shenzhen, Guangdong, China

Tel: (0755) 26639496

Report Number : ACS-F15252  
Date of Test : Jul.22~Aug.25, 2015  
Date of Report : Sep.21, 2015

**TABLE OF CONTENTS**

Description	Page
<b>1. SUMMARY OF STANDARDS AND RESULTS .....</b>	<b>1-1</b>
1.1. Description of Standards and Results.....	1-1
<b>2. GENERAL INFORMATION.....</b>	<b>2-1</b>
2.1. Description of Device (EUT).....	2-1
2.2. Test information.....	2-2
2.3. Tested Supporting System Details.....	2-2
2.4. Block Diagram of Test Setup.....	2-2
2.5. Test Facility.....	2-3
2.6. Measurement Uncertainty (95% confidence levels, k=2).....	2-3
<b>3. POWER LINE CONDUCTED EMISSION TEST.....</b>	<b>3-1</b>
<b>4. RADIATED EMISSION MEASUREMENT .....</b>	<b>4-1</b>
4.1. Test Equipment.....	4-1
4.2. Block Diagram of Test Setup.....	4-2
4.3. Radiated Emission Limit Standard: FCC 15.209.....	4-3
4.4. EUT Configuration on Test.....	4-3
4.5. Operating Condition of EUT.....	4-3
4.6. Test Procedure.....	4-3
4.7. Radiated Emission Test Results.....	4-4
<b>5. CONDUCTED SPURIOUS EMISSIONS .....</b>	<b>5-1</b>
5.1. Test Equipment.....	5-1
5.2. Limit.....	5-1
5.3. Test Procedure.....	5-1
5.4. Test result.....	5-1
<b>6. CARRIER FREQUENCY SEPARATION TEST .....</b>	<b>6-1</b>
6.1. Test Equipment.....	6-1
6.2. Limit.....	6-1
6.3. Test Results.....	6-1
<b>7. 20 DB BANDWIDTH TEST .....</b>	<b>7-1</b>
7.1. Test Equipment.....	7-1
7.2. Limit.....	7-1
7.3. Test Results.....	7-1
<b>8. NUMBER OF HOPPING FREQUENCY TEST .....</b>	<b>8-1</b>
8.1. Test Equipment.....	8-1
8.2. Limit.....	8-1
8.3. Test Results.....	8-1
<b>9. DWELL TIME.....</b>	<b>9-1</b>
9.1. Test Equipment.....	9-1
9.2. Limit.....	9-1
9.3. Test Results.....	9-1
<b>10. MAXIMUM PEAK OUTPUT POWER TEST.....</b>	<b>10-1</b>
10.1. Test Equipment.....	10-1
10.2. Limit.....	10-1
10.3. Test Procedure.....	10-1
10.4. Test Results.....	10-1

<b>11.</b>	<b>BAND EDGE COMPLIANCE TEST .....</b>	<b>11-1</b>
11.1.	Test Equipment .....	11-1
11.2.	Limit.....	11-1
11.3.	Test Produce .....	11-1
11.4.	Test Results .....	11-1
<b>12.</b>	<b>DEVIATION TO TEST SPECIFICATIONS .....</b>	<b>12-1</b>
<b>13.</b>	<b>PHOTOGRAPH OF TEST.....</b>	<b>13-1</b>
13.1.	Photos of Radiated Emission Test.....	13-1
<b>14.</b>	<b>PHOTOS OF THE EUT .....</b>	<b>14-1</b>

## TEST REPORT CERTIFICATION

Applicant : Sounding Audio Industrial Ltd  
Manufacturer : Sounding Audio Industrial Ltd  
EUT Description : Marine Audio System with AM/FM/WB/USB-ipod/Aux in/Bluetooth  
FCC ID : OPDPA4A  
(A) MODEL NO. : PA4A  
(B) Brand Name : POLK  
(C) Serial No. : N/A  
(D) POWER SUPPLY : DC 12V  
(E) TEST VOLTAGE : DC 12V

Tested for comply with:  
FCC Rules and Regulations Part 15 Subpart C: 2014  
Test procedure used:  
ANSI C63.10: 2009

The device described above is tested by AUDIX TECHNOLOGY (SHENZHEN) CO., LTD. to confirm comply with all the FCC Part 15 Subpart C requirements. The test results are contained in this test report and AUDIX TECHNOLOGY (SHENZHEN) CO., LTD. is assumed full responsibility for the accuracy and completeness of these tests. Also, this report shows that the Equipment Under Test (EUT) is to be technically compliant with the FCC and IC requirements. This report contains data that are not covered by the NVLAP accreditation.

This Report is made under FCC Part 2.1075. No modifications were required during testing to bring this product into compliance.

This report applies to above tested sample only. This report shall not be reproduced in part without written approval of AUDIX TECHNOLOGY (SHENZHEN) CO., LTD.

The report must not be used by the client to claim product certification, approval, or endorsement by NVLAP, NIST, or any agency of the federal government.

Date of Test : Jul.22~Aug.25, 2015 Report of date: Sep.21, 2015

Prepared by : Cindy Zhu Reviewed by : Sunny Lu  
Cindy Zhu / Assistant Sunny Lu / Assistant Manager

 信策科技(深圳)有限公司  
Audix Technology (Shenzhen) Co., Ltd.  
EMC 部門報告專用章

Stamp only for EMC Dept. Report

Approved & Authorized Signer : David Jin  
David Jin / Manager

## 1. SUMMARY OF STANDARDS AND RESULTS

### 1.1. Description of Standards and Results

The EUT have been tested according to the applicable standards as referenced below.

EMISSION		
Description of Test Item	Standard	Results
Power Line Conducted Emission Test	FCC Part 15: 15.207 ANSI C63.10 : 2009	N/A
Radiated Emission Test	FCC Part 15: 15.209 FCC Part 15: 15.247(d) ANSI C63.10 : 2009	PASS
Conducted Spurious Emissions	FCC Part 15: 15.247(a)(1) ANSI C63.10 : 2009	PASS
Carrier Frequency Separation Test	FCC Part 15: 15.247(a)(1) ANSI C63.10 : 2009	PASS
20dB Bandwidth Test	FCC Part 15: 15.215 ANSI C63.10 : 2009	PASS
Number Of Hopping Frequency Test	FCC Part 15: 15.247(a)(1)(iii) ANSI C63.10 : 2009	PASS
Dwell Time Test	FCC Part 15: 15.247(a)(1)(iii) ANSI C63.10 : 2009	PASS
Maximum Peak Output Power Test	FCC Part 15: 15.247(b)(1)\ ANSI C63.10 : 2009	PASS
Band Edge Compliance Test	FCC Part 15: 15.247(d) ANSI C63.10 : 2009	PASS

## 2. GENERAL INFORMATION

### 2.1. Description of Device (EUT)

EUT name	: Marine Audio System with AM/FM/WB/USB-ipod/Aux in/Bluetooth
Model Number	: PA4A
Brand Name	: POLK
FCC ID	: OPDPA4A
Radio	: Bluetooth V2.1 + EDR
Operation frequency	: 2402-2480MHz
Channel Number	: 79 channels
Modulation Technology	: GFSK, $\pi/4$ DQPSK, 8-DPSK
Antenna Type	: Embedded with designed PCB antenna, 0dBi PK Gain
Applicant	: Sounding Audio Industrial Ltd Unit N, 7/F, Stage 2. Wah Fung Industrial Centre 33-39 Kwai Chung Road, Kwai Chung, Hong Kong
Manufacturer	: Sounding Audio Industrial Ltd Unit N, 7/F, Stage 2. Wah Fung Industrial Centre 33-39 Kwai Chung Road, Kwai Chung, Hong Kong
Date of Test	: Jul.22~Aug.25, 2015
Date of Receipt	: Jul.20, 2015
Sample Type	: Prototype production

### 2.2. Test information

A special test software was used to control EUT work in Continuous TX mode, and select test channel.

Tested mode, channel, and data rate information			
Mode	data rate (Mbps)	Channel	Frequency (MHz)
Tx Mode GFSK modulation	1	Low :CH 0	2402
	1	Middle: CH39	2441
	1	High: CH78	2480
Tx Mode 8-DPSK modulation	3	Low :CH 0	2402
	3	Middle: CH39	2441
	3	High: CH78	2480

Note:  $\pi/4$ DQPSK modulation is same type modulation with 8-DPSK, and according exploratory test, 8-DPSK will have worse emissions, so the final test were only performed with GFSK and 8-DPSK modulation.

### 2.3. Tested Supporting System Details

No.	Description	ACS No.	Manufacturer	Model	Serial Number	Approved type
1	Speaker #1	N/A	SONY	SS-CMX700	N/A	N/A
		Cable: Shielded, Undetachabled, 0.9m				
2	Speaker #2	N/A	SONY	SS-CEH45	N/A	N/A
		Cable: Shielded, Undetachabled, 0.9m				
3	Ipod	ACS-EMC-IP01	APPLE	A1199	YM706MLDVQ5	N/A

### 2.4. Block Diagram of Test Setup

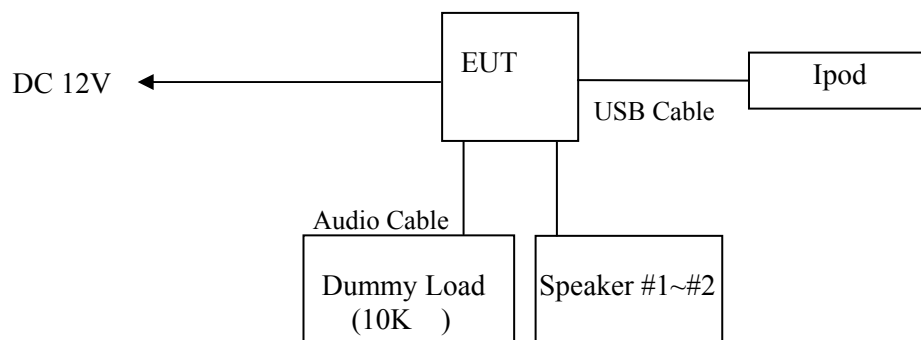

(EUT: Marine Audio System with AM/FM/WB/USB-ipod/Aux in/Bluetooth)

**2.5. Test Facility**

Site Description

Name of Firm : Audix Technology (Shenzhen) Co., Ltd.  
 No. 6, Ke Feng Rd., 52 Block, Shenzhen  
 Science & Industrial Park, Nantou, Shenzhen,  
 Guangdong, China

3m Anechoic Chamber : Certificated by FCC, USA  
 Registration Number: 90454  
 Valid Date: Dec.30, 2017

3m & 10m Anechoic Chamber : Certificated by FCC, USA  
 Registration Number: 794232  
 Valid Date: Jul.12, 2017

EMC Lab. : Certificated by Industry Canada  
 Registration Number: IC 5183A-1  
 Valid Date: May.14, 2017

: Certificated by DAkkS, Germany  
 Registration No: D-PL-12151-01-00  
 Valid Date: Dec.15, 2016

: Accredited by NVLAP, USA  
 NVLAP Code: 200372-0  
 Valid Date: Mar.31, 2016

**2.6. Measurement Uncertainty (95% confidence levels, k=2)**

Test Item	Uncertainty
Uncertainty for Conduction emission test in No. 1 Conduction	3.4 dB(150kHz to 30MHz)
Uncertainty for Radiation Emission test in 3m chamber	3.0 dB(30~200MHz, Polarization: H)
	3.0 dB(30~200MHz, Polarization: V)
	3.2 dB(200M~1GHz, Polarization: H)
	3.1 dB(200M~1GHz, Polarization: V)
Uncertainty for Radiation Emission test in 3m chamber (1GHz-18GHz)	6.3 dB(1~6GHz, Distance: 3m)
	5.7 dB(6~18GHz, Distance: 3m)
Uncertainty for Radiated Spurious Emission test in RF chamber	3.6 dB
Uncertainty for Conduction Spurious emission test	2.0 dB
Uncertainty for Output power test	0.8 dB
Uncertainty for Bandwidth test	83 kHz
Uncertainty for DC power test	0.1 %
Uncertainty for test site temperature and humidity	0.6
	3%



### **3. POWER LINE CONDUCTED EMISSION TEST**

According to Paragraph (c) of FCC Part 15 section 15.207, Tests to demonstrate compliance with the conducted limits are not required for devices which only employ battery power for operation and which do not operate from the AC power lines or contain provisions for operation while connected to the AC power lines.

## 4. RADIATED EMISSION MEASUREMENT

### 4.1. Test Equipment

Frequency rang: 30~1000MHz (In 3m Anechoic Chamber)

Item	Equipment	Manufacturer	Model No.	Serial No.	Last Cal.	Cal. Interval
1.	3#Chamber	AUDIX	N/A	N/A	Nov.23,14	1 Year
2.	EMI Spectrum	Agilent	E4407B	MY41440292	Apr.28,15	1 Year
3.	Test Receiver	Rohde & Schwarz	ESVS10	834468/011	Apr.28,15	1 Year
4.	Amplifier	HP	8447D	2648A04738	Apr.28,15	1 Year
5.	Trilog-Broadband Antenna	SCHWARZBECK	VULB 9168	9168-493	May.06,15	1 Year
6.	RF Cable	MIYAZAKI	CFD400-N W(3.5M)	No.3	Apr.28,15	1 Year
7.	RF Cable	MIYAZAKI	CFD400-L W(22M)	No.7	Apr.28,15	1 Year
8.	Coaxial Switch	Anritsu	MP59B	6201397222	Apr.28,15	1 Year

4.1.1. For frequency range 1GHz~25GHz (In 3m Anechoic Chamber)

Item	Equipment	Manufacturer	Model No.	Serial No.	Last Cal.	Cal. Interval
1.	3#Chamber	AUDIX	N/A	N/A	Nov.02, 14	1 Year
2.	Spectrum Analyzer	Agilent	E4407B	MY41440292	Apr. 28,15	1 Year
3.	Horn Antenna	ETS	3115	9607-4877	Sep.20, 14	1 Year
4.	Amplifier	Agilent	8449B	3008A00863	Apr. 28,15	1 Year
5.	RF Cable	Hubersuhner	SUCOFLEX106	77977/6	Apr. 28,15	1 Year
6.	RF Cable	Hubersuhner	SUCOFLEX106	28616/2	Apr. 28,15	1 Year
7.	Horn Antenna	ETS	3116	00060089	Sep.20, 14	1 Year

### 4.2. Block Diagram of Test Setup

For frequency range 30MHz-1000MHz

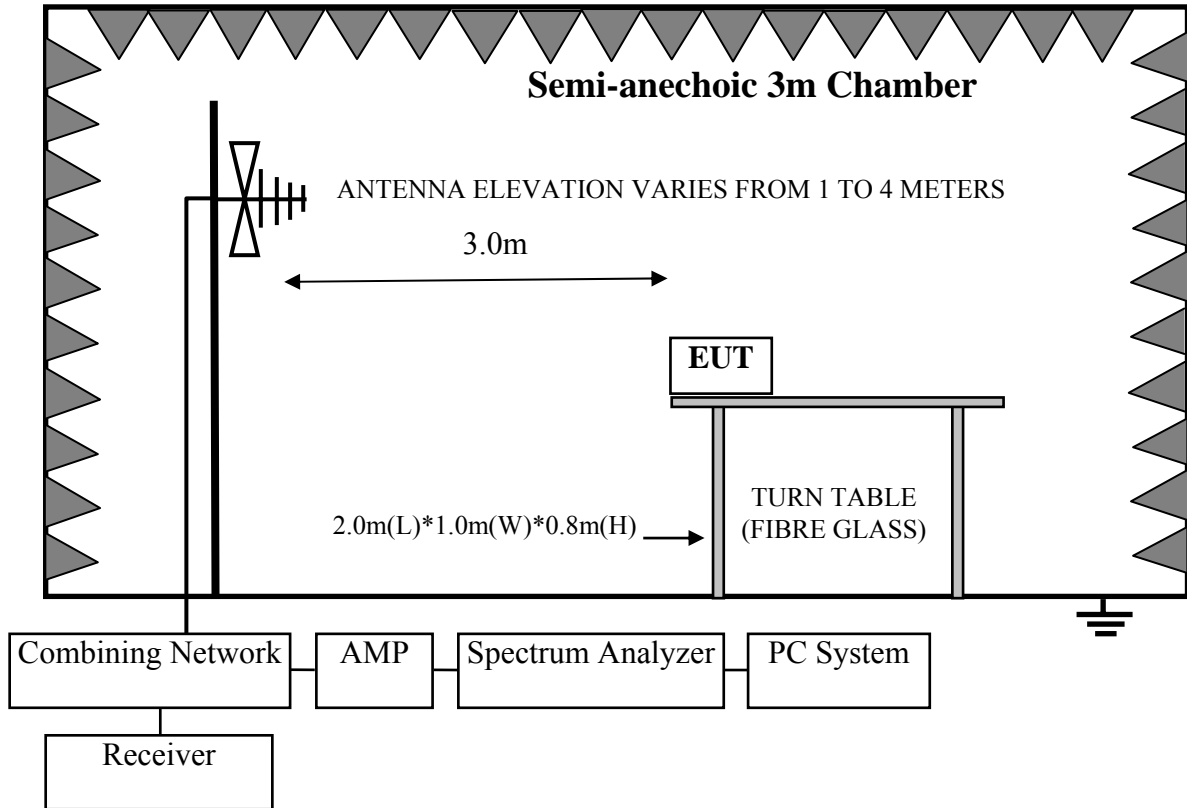

For frequency range 1GHz-25GHz

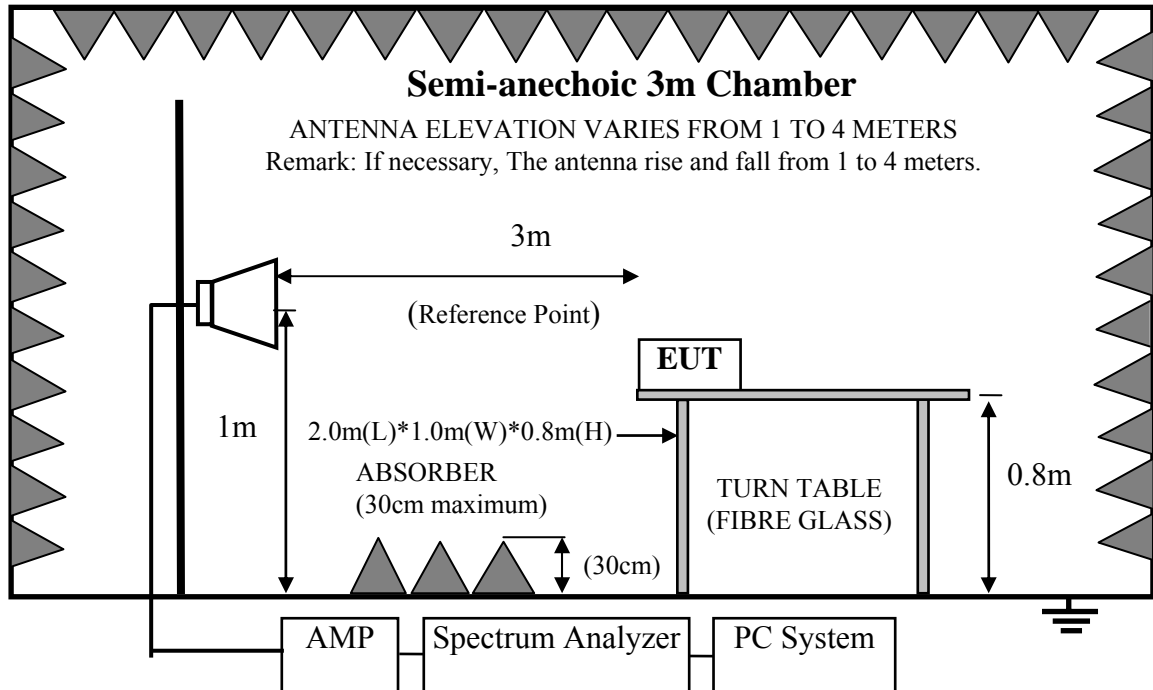

### 4.3. Radiated Emission Limit Standard: FCC 15.209

FREQUENCY MHz	DISTANCE Meters	FIELD STRENGTHS LIMIT	
		μV/m	dB(μV)/m
30 ~ 88	3	100	40.0
88 ~ 216	3	150	43.5
216 ~ 960	3	200	46.0
960 ~ 1000	3	500	54.0
Above 1000MHz	3	74.0 dB(μV)/m (Peak) 54.0 dB(μV)/m (Average)	

Remark : (1) Emission level dBμV = 20 log Emission level μV/m

- (2) The smaller limit shall apply at the cross point between two frequency bands.
- (3) Distance is the distance in meters between the measuring instrument, antenna and the closest point of any part of the device or system.
- (4) The emission limits shown in the above table are based on measurements employing a CISPR quasi-peak detector except for the frequency bands 9-90 kHz, 110-490 kHz and above 1000 MHz. Radiated emission limits in these three bands are based on measurements employing an average detector.

### 4.4.EUT Configuration on Test

The following equipment are installed on Power Line Conducted Emission Test to meet the commission requirement and operating regulations in a manner which tends to maximize its emission characteristics in a normal application.

#### 4.4.1.Marine Audio System with AM/FM/WB/USB-ipod/Aux in/Bluetooth (EUT)

Model Number: PA4A

Serial Number : N/A

#### 4.4.2.Support Equipment: As Tested Supporting System Details, in Section 2.2.

### 4.5.Operating Condition of EUT

4.5.1.Setup the EUT and simulator as shown as Section 4.2.

4.5.2.Turned on the power of all equipment.

4.5.3.Let EUT work in Tx mode.

### 4.6.Test Procedure

The EUT and its simulators are placed on a turn table, which is 0.8 meter high above ground. The turn table can rotate 360 degrees to determine the position of the maximum emission level. The EUT is set 3 meters away from the receiving antenna, which is mounted on a antenna tower. The antenna can be moved up and down between 1 meter and 4 meters to find out the maximum emission level. Broadband antenna (calibrated bilog antenna) is used as receiving antenna. Both horizontal and vertical polarization of the antenna is set on Test. In order to find the maximum emission levels, all of the interface cables must be manipulated according to ANSI C63.10: 2009 on radiated emission Test.

This test was performed with EUT in X, Y, Z position, and the worse case was found when EUT in X position as the test photo indicated.

The bandwidth of the EMI test receiver (R&S ESVS10) is set at 120kHz for frequency range from 30MHz to 1000 MHz.

The bandwidth of the Spectrum's RBW is set at 1MHz and VBW is set at 3MHz for peak emissions measurement above 1GHz

This device is pulse Modulated, a duty cycle factor was used to calculated average level based measured peak level.

The frequency range from 30MHz to 10th harmonic (25GHz) are checked. and no any emissions were found from 18GHz to 25 GHz, So the radiated emissions from 18GHz to 25GHz were not record.

#### 4.7. Radiated Emission Test Results

**PASS.**

All the emissions from 30MHz to 25GHz were comply with the 15.209 Limit.

Note: The duty cycle factor for calculate average level is -30.371 dB, and average limit is 20dB below peak limit, so if peak measured level comply with average limit, the average level was deemed to comply with average limit.

$$\text{Duty cycle factor} = 20\log (\text{Dwell time}/100\text{ms}) = -30.371$$

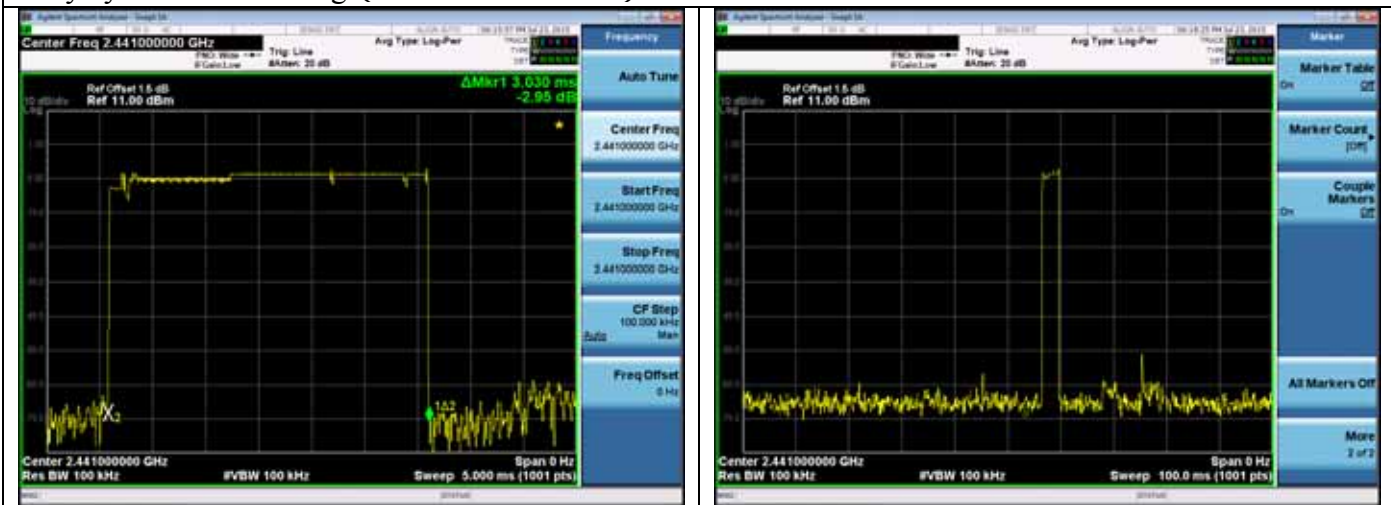

### Frequency: 30MHz~1GHz

Data: 1 File: E:\2015 Report Data\Eagle\ACS1501310-RF.EM6 (2) Date: 2015-08-25

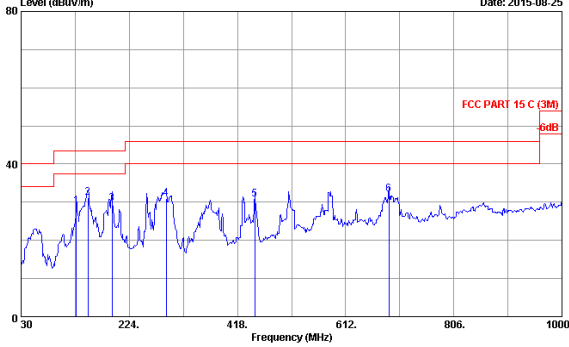

Site no. : 3m Chamber Data no. : 1  
 Dis. / Ant. : 3m 2015 VULB 9168-493 Ant. pol. : HORIZONTAL  
 Limit : FCC PART 15 C (3M)  
 Env. / Ins. : 24°C/56% Engineer : Frank  
 EUT : Marine Audio System with AM/FM/USB-mpod/Aux in/Bluetooth  
 Power rating : DC 12V  
 Test Mode : Tx mode  
 M/N : PA4A

No.	Freq. (MHz)	Ant. Factor (dB/m)	Cable Loss (dB)	Reading (dBuV)	Emission Level (dBuV/m)	Limits (dBuV/m)	Margin (dB)	Remark
1	128.940	13.18	1.21	14.61	29.00	43.50	14.50	QP
2	150.280	14.30	1.29	15.51	31.10	43.50	12.40	QP
3	192.960	11.55	1.49	16.62	29.66	43.50	13.84	QP
4	289.960	13.85	1.84	15.33	31.02	46.00	14.98	QP
5	449.040	17.09	2.36	11.41	30.86	46.00	15.14	QP
6	689.600	21.21	3.00	7.78	31.99	46.00	14.01	QP

Remarks: 1. Emission Level= Antenna Factor + Cable Loss + Reading.  
 2. The emission levels that are 20dB below the official limit are not reported.

Data: 2 File: E:\2015 Report Data\Eagle\ACS1501310-RF.EM6 (2) Date: 2015-08-25

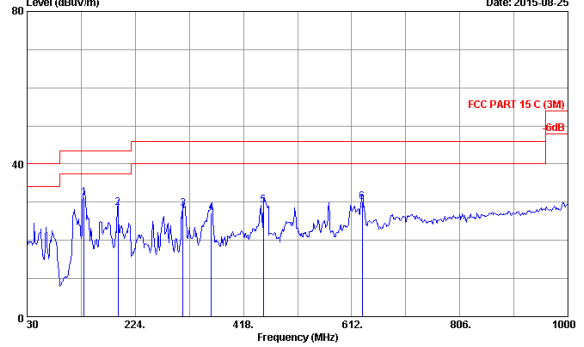

Site no. : 3m Chamber Data no. : 2  
 Dis. / Ant. : 3m 2015 VULB 9168-493 Ant. pol. : VERTICAL  
 Limit : FCC PART 15 C (3M)  
 Env. / Ins. : 24°C/56% Engineer : Frank  
 EUT : Marine Audio System with AM/FM/USB-mpod/Aux in/Bluetooth  
 Power rating : DC 12V  
 Test Mode : Tx mode  
 M/N : PA4A

No.	Freq. (MHz)	Ant. Factor (dB/m)	Cable Loss (dB)	Reading (dBuV)	Emission Level (dBuV/m)	Limits (dBuV/m)	Margin (dB)	Remark
1	131.850	13.44	1.24	16.44	31.12	43.50	12.38	QP
2	192.960	11.55	1.49	15.42	28.46	43.50	15.04	QP
3	309.960	14.29	1.92	12.12	28.33	46.00	17.67	QP
4	360.770	15.40	2.10	9.78	27.28	46.00	18.72	QP
5	453.890	17.16	2.38	9.74	29.28	46.00	16.72	QP
6	631.400	20.31	2.84	6.98	30.13	46.00	15.87	QP

Remarks: 1. Emission Level= Antenna Factor + Cable Loss + Reading.  
 2. The emission levels that are 20dB below the official limit are not reported.

### Frequency: 1GHz~18GHz

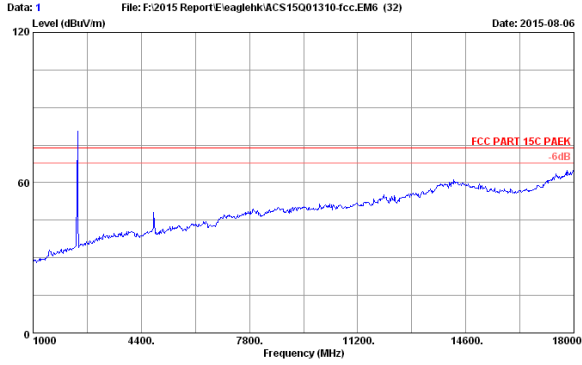

Site no. : 3m Chamber Data no. : 1  
 Dis. / Ant. : 3m 2014 3115 (4580) Ant. pol. : HORIZONTAL  
 Limit : FCC PART 15C PAEK  
 Env. / Ins. : 22.5°C/51.6%  
 Engineer : Donjon Huang  
 EUT : Marine Audio System with AM/FM/WB/USB-IPod/Aux in/Bluetooth  
 Power rating : DC 12V  
 Test Mode : GFSK 2402MHz Tx Mode  
 M/N : P4A4

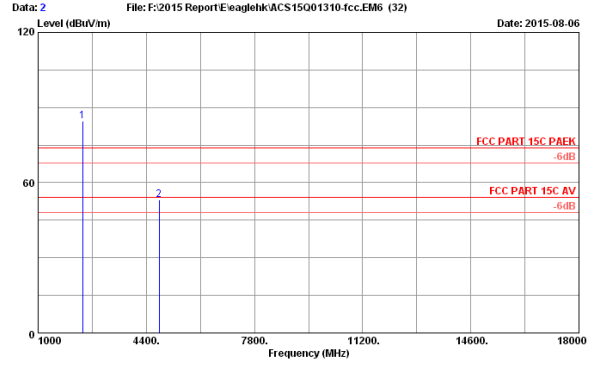

Site no. : 3m Chamber Data no. : 2  
 Dis. / Ant. : 3m 2014 3115 (4580) Ant. pol. : HORIZONTAL  
 Limit : FCC PART 15C PAEK  
 Env. / Ins. : 22.5°C/51.6%  
 Engineer : Donjon Huang  
 EUT : Marine Audio System with AM/FM/WB/USB-IPod/Aux in/Bluetooth  
 Power rating : DC 12V  
 Test Mode : GFSK 2402MHz Tx Mode  
 M/N : P4A4

No.	Freq. (MHz)	Ant. Factor (dB/m)	Cable Loss (dB)	AMP factor (dB)	Reading (dBuV)	Emission Level (dBuV/m)	Limits (dBuV/m)	Margin (dB)	Remark
1	2402.000	28.18	5.80	35.70	86.35	84.63	74.00	-10.63	Peak
2	4804.000	32.85	8.56	35.70	47.51	53.22	74.00	20.78	Peak

Remarks: 1. Emission Level= Antenna Factor + Cable Loss + Reading - Amp Factor  
 2. The emission levels that are 20dB below the official limit are not reported.

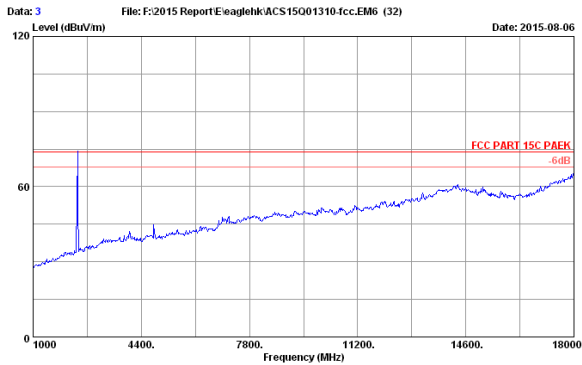

Site no. : 3m Chamber Data no. : 3  
 Dis. / Ant. : 3m 2014 3115 (4580) Ant. pol. : VERTICAL  
 Limit : FCC PART 15C PAEK  
 Env. / Ins. : 22.5°C/51.6%  
 Engineer : Donjon Huang  
 EUT : Marine Audio System with AM/FM/WB/USB-IPod/Aux in/Bluetooth  
 Power rating : DC 12V  
 Test Mode : GFSK 2402MHz Tx Mode  
 M/N : P4A4

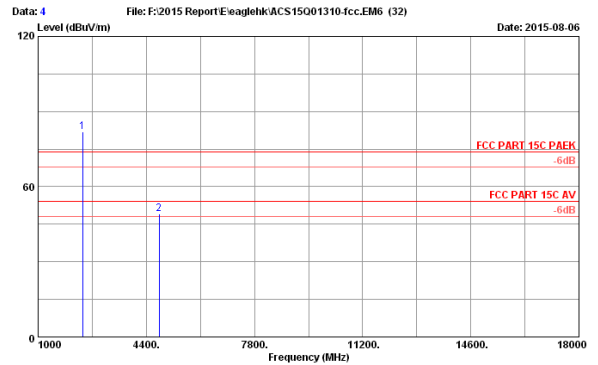

Site no. : 3m Chamber Data no. : 4  
 Dis. / Ant. : 3m 2014 3115 (4580) Ant. pol. : VERTICAL  
 Limit : FCC PART 15C PAEK  
 Env. / Ins. : 22.5°C/51.6%  
 Engineer : Donjon Huang  
 EUT : Marine Audio System with AM/FM/WB/USB-IPod/Aux in/Bluetooth  
 Power rating : DC 12V  
 Test Mode : GFSK 2402MHz Tx Mode  
 M/N : P4A4

No.	Freq. (MHz)	Ant. Factor (dB/m)	Cable Loss (dB)	AMP factor (dB)	Reading (dBuV)	Emission Level (dBuV/m)	Limits (dBuV/m)	Margin (dB)	Remark
1	2402.000	28.18	5.80	35.70	83.70	81.98	74.00	-7.98	Peak
2	4804.000	32.85	8.56	35.70	43.57	49.28	74.00	24.72	Peak

Remarks: 1. Emission Level= Antenna Factor + Cable Loss + Reading - Amp Factor  
 2. The emission levels that are 20dB below the official limit are not reported.

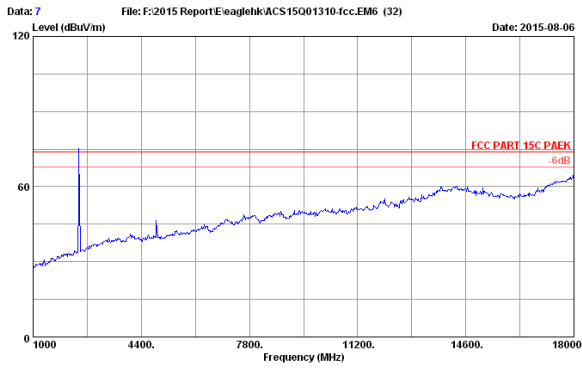

Site no. : 3m Chamber Data no. : 7  
 Dis. / Ant. : 3m 2014 3115 (4580) Ant. pol. : HORIZONTAL  
 Limit : FCC PART 15C PAKK  
 Env. / Ins. : 22.5°C/51.6%  
 Engineer : Donjon Huang  
 EUT : Marine Audio System with AM/FM/WB/USB-mpod/Aux in/Bluetooth  
 Power rating : DC 12V  
 Test Mode : GFSK 2441MHz Tx Mode  
 M/N : PA4A

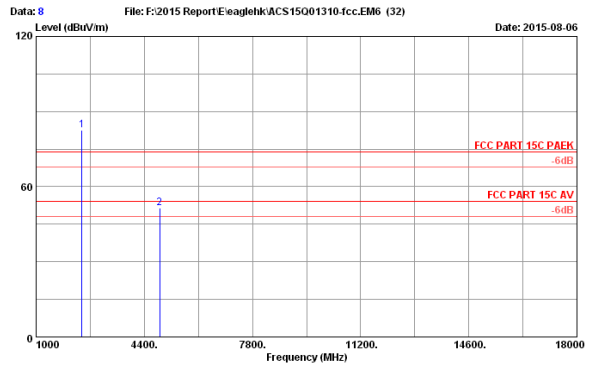

Site no. : 3m Chamber Data no. : 8  
 Dis. / Ant. : 3m 2014 3115 (4580) Ant. pol. : HORIZONTAL  
 Limit : FCC PART 15C PAKK  
 Env. / Ins. : 22.5°C/51.6%  
 Engineer : Donjon Huang  
 EUT : Marine Audio System with AM/FM/WB/USB-mpod/Aux in/Bluetooth  
 Power rating : DC 12V  
 Test Mode : GFSK 2441MHz Tx Mode  
 M/N : PA4A

No.	Freq. (MHz)	Ant. Factor (dB/m)	Cable Loss (dB)	AMP factor (dB)	Reading (dBuV)	Emission Level (dBuV/m)	Limits (dBuV/m)	Margin (dB)	Remark
1	2441.000	28.27	5.86	35.70	84.00	82.43	74.00	-8.43	Peak
2	4882.000	32.99	8.64	35.70	45.49	51.42	74.00	22.58	Peak

Remarks: 1. Emission Level= Antenna Factor + Cable Loss + Reading - Amp Factor  
 2. The emission levels that are 20dB below the official limit are not reported.

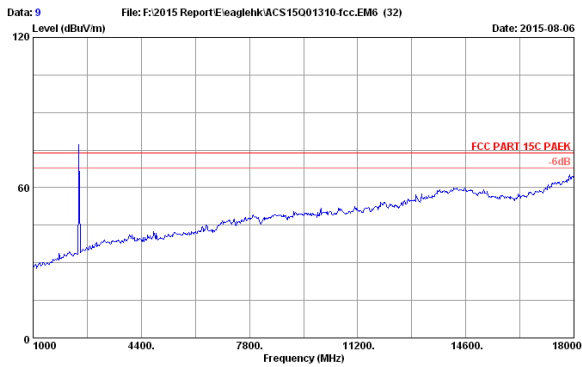

Site no. : 3m Chamber Data no. : 9  
 Dis. / Ant. : 3m 2014 3115 (4580) Ant. pol. : VERTICAL  
 Limit : FCC PART 15C PAKK  
 Env. / Ins. : 22.5°C/51.6%  
 Engineer : Donjon Huang  
 EUT : Marine Audio System with AM/FM/WB/USB-mpod/Aux in/Bluetooth  
 Power rating : DC 12V  
 Test Mode : GFSK 2441MHz Tx Mode  
 M/N : PA4A

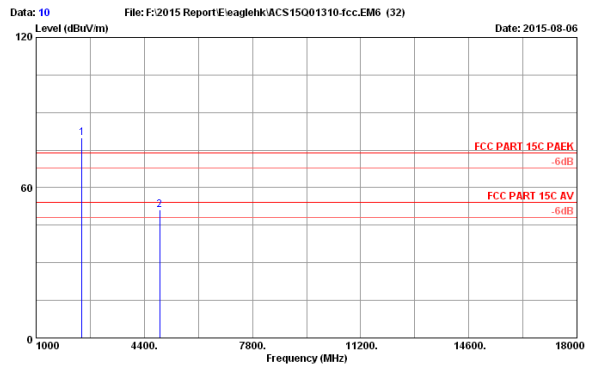

Site no. : 3m Chamber Data no. : 10  
 Dis. / Ant. : 3m 2014 3115 (4580) Ant. pol. : VERTICAL  
 Limit : FCC PART 15C PAKK  
 Env. / Ins. : 22.5°C/51.6%  
 Engineer : Donjon Huang  
 EUT : Marine Audio System with AM/FM/WB/USB-mpod/Aux in/Bluetooth  
 Power rating : DC 12V  
 Test Mode : GFSK 2441MHz Tx Mode  
 M/N : PA4A

No.	Freq. (MHz)	Ant. Factor (dB/m)	Cable Loss (dB)	AMP factor (dB)	Reading (dBuV)	Emission Level (dBuV/m)	Limits (dBuV/m)	Margin (dB)	Remark
1	2441.000	28.27	5.86	35.70	81.60	80.03	74.00	-6.03	Peak
2	4882.000	32.99	8.64	35.70	45.27	51.20	74.00	22.80	Peak

Remarks: 1. Emission Level= Antenna Factor + Cable Loss + Reading - Amp Factor  
 2. The emission levels that are 20dB below the official limit are not reported.



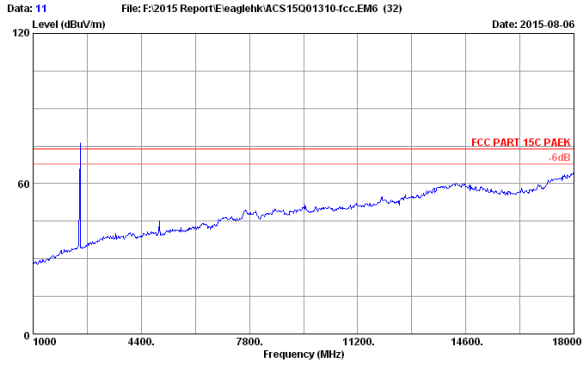

Site no. : 3m Chamber Data no. : 11  
 Dis. / Ant. : 3m 2014 3115 (4580) Ant. pol. : HORIZONTAL  
 Limit : FCC PART 15C PAK  
 Env. / Ins. : 22.5°C/51.6%  
 Engineer : Donjon\_Huang  
 EUT : Marine Audio System with AM/FM/WB/USB-mpod/Aux in/Bluetooth  
 Power rating : DC 12V  
 Test Mode : GFSK 2480MHz Tx Mode  
 M/N : PA4A

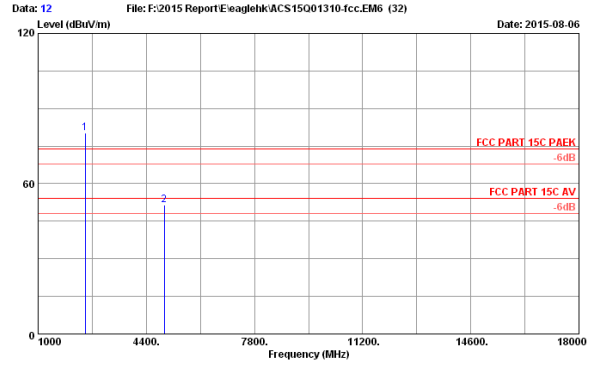

Site no. : 3m Chamber Data no. : 12  
 Dis. / Ant. : 3m 2014 3115 (4580) Ant. pol. : HORIZONTAL  
 Limit : FCC PART 15C PAK  
 Env. / Ins. : 22.5°C/51.6%  
 Engineer : Donjon\_Huang  
 EUT : Marine Audio System with AM/FM/WB/USB-mpod/Aux in/Bluetooth  
 Power rating : DC 12V  
 Test Mode : GFSK 2480MHz Tx Mode  
 M/N : PA4A

No.	Freq. (MHz)	Ant. Factor (dB/m)	Cable Loss (dB)	AMP factor (dB)	Reading (dBuV)	Emission Level (dBuV/m)	Limits (dBuV/m)	Margin (dB)	Remark
1	2480.000	28.36	5.91	35.70	81.74	80.31	74.00	-6.31	Peak
2	4960.000	33.13	8.72	35.70	45.38	51.53	74.00	22.47	Peak

Remarks: 1. Emission Level= Antenna Factor + Cable Loss + Reading - Amp Factor  
 2. The emission levels that are 20dB below the official limit are not reported.

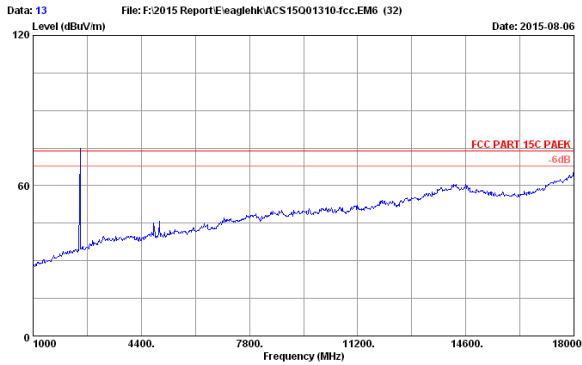

Site no. : 3m Chamber Data no. : 13  
 Dis. / Ant. : 3m 2014 3115 (4580) Ant. pol. : VERTICAL  
 Limit : FCC PART 15C PAK  
 Env. / Ins. : 22.5°C/51.6%  
 Engineer : Donjon\_Huang  
 EUT : Marine Audio System with AM/FM/WB/USB-mpod/Aux in/Bluetooth  
 Power rating : DC 12V  
 Test Mode : GFSK 2480MHz Tx Mode  
 M/N : PA4A

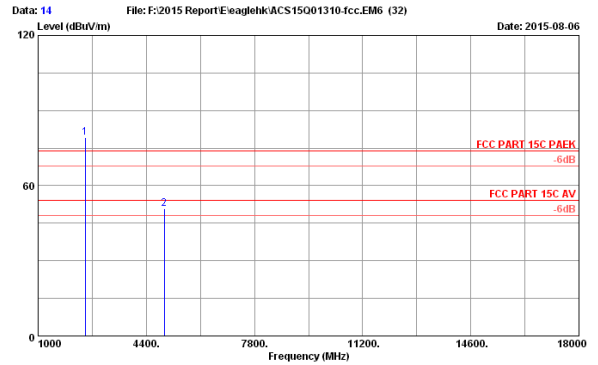

Site no. : 3m Chamber Data no. : 14  
 Dis. / Ant. : 3m 2014 3115 (4580) Ant. pol. : VERTICAL  
 Limit : FCC PART 15C PAK  
 Env. / Ins. : 22.5°C/51.6%  
 Engineer : Donjon\_Huang  
 EUT : Marine Audio System with AM/FM/WB/USB-mpod/Aux in/Bluetooth  
 Power rating : DC 12V  
 Test Mode : GFSK 2480MHz Tx Mode  
 M/N : PA4A

No.	Freq. (MHz)	Ant. Factor (dB/m)	Cable Loss (dB)	AMP factor (dB)	Reading (dBuV)	Emission Level (dBuV/m)	Limits (dBuV/m)	Margin (dB)	Remark
1	2480.000	28.36	5.91	35.70	80.59	79.16	74.00	-5.16	Peak
2	4960.000	33.13	8.72	35.70	44.77	50.92	74.00	23.08	Peak

Remarks: 1. Emission Level= Antenna Factor + Cable Loss + Reading - Amp Factor  
 2. The emission levels that are 20dB below the official limit are not reported.

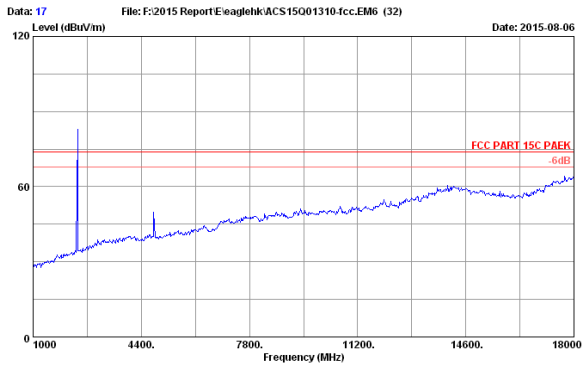

Site no. : 3m Chamber Data no. : 17  
 Dis. / Ant. : 3m 2014 3115 (4580) Ant. pol. : HORIZONTAL  
 Limit : FCC PART 15C PAKK  
 Env. / Ins. : 22.5°C/51.6%  
 Engineer : Donjon\_Huang  
 EUT : Marine Audio System with AM/FM/WB/USB-mpod/Aux in/Bluetooth  
 Power rating : DC 12V  
 Test Mode : 8-DPSK 2402MHz Tx Mode  
 M/N : PA4A



Site no. : 3m Chamber Data no. : 18  
 Dis. / Ant. : 3m 2014 3115 (4580) Ant. pol. : HORIZONTAL  
 Limit : FCC PART 15C PAKK  
 Env. / Ins. : 22.5°C/51.6%  
 Engineer : Donjon\_Huang  
 EUT : Marine Audio System with AM/FM/WB/USB-mpod/Aux in/Bluetooth  
 Power rating : DC 12V  
 Test Mode : 8-DPSK 2402MHz Tx Mode  
 M/N : PA4A

No.	Freq. (MHz)	Ant. Factor (dB/m)	Cable Loss (dB)	AMP factor (dB)	Reading (dBuV)	Emission Level (dBuV/m)	Limits (dBuV/m)	Margin (dB)	Remark
1	2402.000	28.18	5.80	35.70	85.25	83.53	74.00	-9.53	Peak
2	4804.000	32.85	8.56	35.70	44.38	50.09	74.00	23.91	Peak

Remarks: 1. Emission Level= Antenna Factor + Cable Loss + Reading - Amp Factor  
 2. The emission levels that are 20dB below the official limit are not reported.

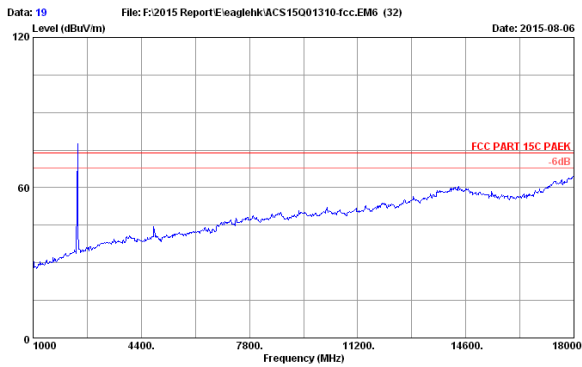

Site no. : 3m Chamber Data no. : 19  
 Dis. / Ant. : 3m 2014 3115 (4580) Ant. pol. : VERTICAL  
 Limit : FCC PART 15C PAKK  
 Env. / Ins. : 22.5°C/51.6%  
 Engineer : Donjon\_Huang  
 EUT : Marine Audio System with AM/FM/WB/USB-mpod/Aux in/Bluetooth  
 Power rating : DC 12V  
 Test Mode : 8-DPSK 2402MHz Tx Mode  
 M/N : PA4A

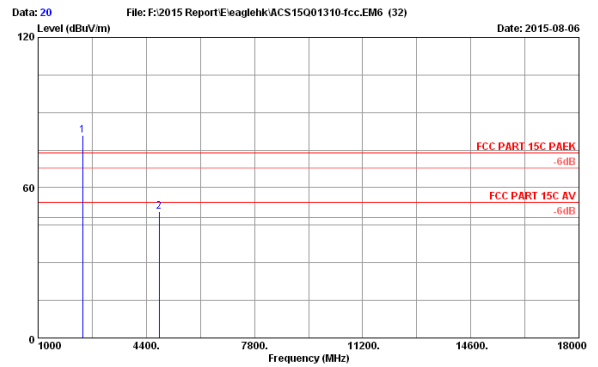

Site no. : 3m Chamber Data no. : 20  
 Dis. / Ant. : 3m 2014 3115 (4580) Ant. pol. : VERTICAL  
 Limit : FCC PART 15C PAKK  
 Env. / Ins. : 22.5°C/51.6%  
 Engineer : Donjon\_Huang  
 EUT : Marine Audio System with AM/FM/WB/USB-mpod/Aux in/Bluetooth  
 Power rating : DC 12V  
 Test Mode : 8-DPSK 2402MHz Tx Mode  
 M/N : PA4A

No.	Freq. (MHz)	Ant. Factor (dB/m)	Cable Loss (dB)	AMP factor (dB)	Reading (dBuV)	Emission Level (dBuV/m)	Limits (dBuV/m)	Margin (dB)	Remark
1	2402.000	28.18	5.80	35.70	82.51	80.79	74.00	-6.79	Peak
2	4804.000	32.85	8.56	35.70	44.80	50.51	74.00	23.49	Peak

Remarks: 1. Emission Level= Antenna Factor + Cable Loss + Reading - Amp Factor  
 2. The emission levels that are 20dB below the official limit are not reported.

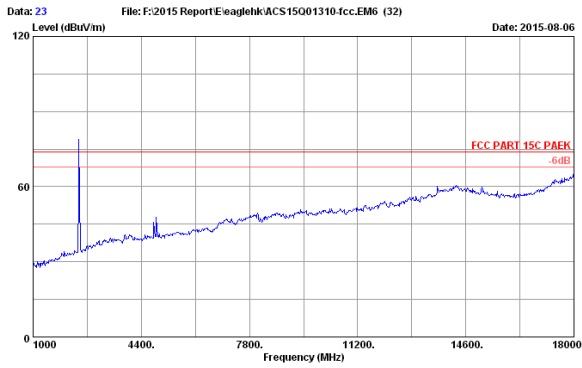

Site no. : 3m Chamber Data no. : 23  
 Dis. / Ant. : 3m 2014 3115 (4580) Ant. pol. : HORIZONTAL  
 Limit : FCC PART 15C PAEK  
 Env. / Ins. : 22.5°C/51.6%  
 Engineer : Donjon\_Huang  
 EUT : Marine Audio System with AM/FM/WB/USB-mpod/Aux in/Bluetooth  
 Power rating : DC 12V  
 Test Mode : 8-DPSK 2441MHz Tx Mode  
 M/N : PA4A

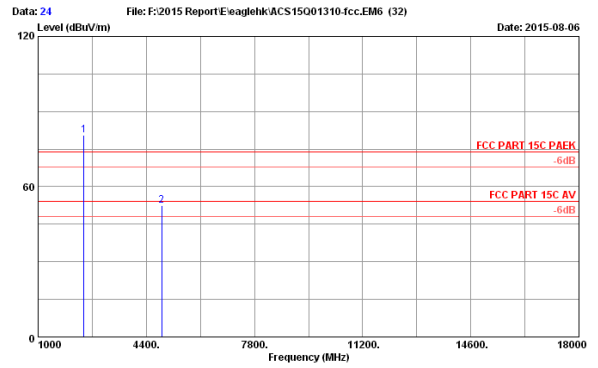

Site no. : 3m Chamber Data no. : 24  
 Dis. / Ant. : 3m 2014 3115 (4580) Ant. pol. : HORIZONTAL  
 Limit : FCC PART 15C PAEK  
 Env. / Ins. : 22.5°C/51.6%  
 Engineer : Donjon\_Huang  
 EUT : Marine Audio System with AM/FM/WB/USB-mpod/Aux in/Bluetooth  
 Power rating : DC 12V  
 Test Mode : 8-DPSK 2441MHz Tx Mode  
 M/N : PA4A

No.	Freq. (MHz)	Ant. Factor (dB/m)	Cable Loss (dB)	AMP factor (dB)	Reading (dBuV)	Emission Level (dBuV/m)	Limits (dBuV/m)	Margin (dB)	Remark
1	2441.000	28.27	5.86	35.70	81.97	80.40	74.00	-6.40	Peak
2	4882.000	32.99	8.64	35.70	46.51	52.44	74.00	21.56	Peak

Remarks: 1. Emission Level= Antenna Factor + Cable Loss + Reading - Amp Factor  
 2. The emission levels that are 20dB below the official limit are not reported.

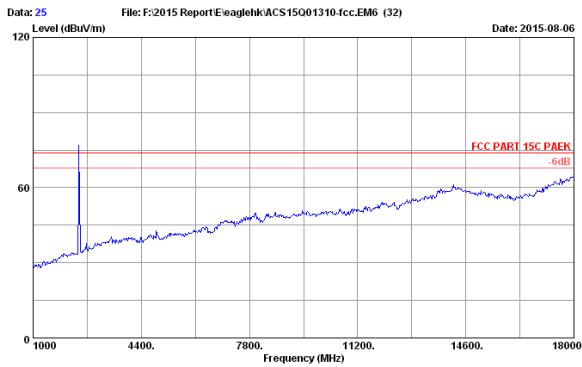

Site no. : 3m Chamber Data no. : 25  
 Dis. / Ant. : 3m 2014 3115 (4580) Ant. pol. : VERTICAL  
 Limit : FCC PART 15C PAEK  
 Env. / Ins. : 22.5°C/51.6%  
 Engineer : Donjon\_Huang  
 EUT : Marine Audio System with AM/FM/WB/USB-mpod/Aux in/Bluetooth  
 Power rating : DC 12V  
 Test Mode : 8-DPSK 2441MHz Tx Mode  
 M/N : PA4A



Site no. : 3m Chamber Data no. : 26  
 Dis. / Ant. : 3m 2014 3115 (4580) Ant. pol. : VERTICAL  
 Limit : FCC PART 15C PAEK  
 Env. / Ins. : 22.5°C/51.6%  
 Engineer : Donjon\_Huang  
 EUT : Marine Audio System with AM/FM/WB/USB-mpod/Aux in/Bluetooth  
 Power rating : DC 12V  
 Test Mode : 8-DPSK 2441MHz Tx Mode  
 M/N : PA4A

No.	Freq. (MHz)	Ant. Factor (dB/m)	Cable Loss (dB)	AMP factor (dB)	Reading (dBuV)	Emission Level (dBuV/m)	Limits (dBuV/m)	Margin (dB)	Remark
1	2441.000	28.27	5.86	35.70	81.03	79.46	74.00	-5.46	Peak
2	4882.000	32.99	8.64	35.70	44.51	50.44	74.00	23.56	Peak

Remarks: 1. Emission Level= Antenna Factor + Cable Loss + Reading - Amp Factor  
 2. The emission levels that are 20dB below the official limit are not reported.

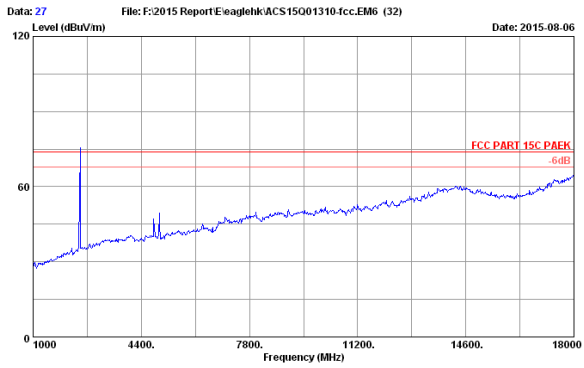

Site no. : 3m Chamber Data no. : 27  
 Dis. / Ant. : 3m 2014 3115 (4580) Ant. pol. : HORIZONTAL  
 Limit : FCC PART 15C PAEK  
 Env. / Ins. : 22.5°C/51.6%  
 Engineer : Donjon\_Huang  
 EUT : Marine Audio System with AM/FM/WB/USB-mpod/Aux in/Bluetooth  
 Power rating : DC 12V  
 Test Mode : 8-DPSK 2480MHz Tx Mode  
 M/N : PA4A

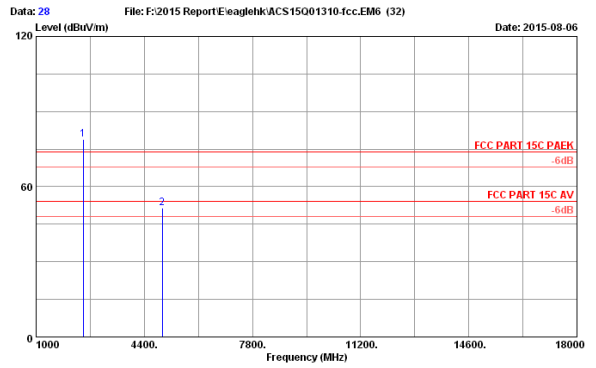

Site no. : 3m Chamber Data no. : 28  
 Dis. / Ant. : 3m 2014 3115 (4580) Ant. pol. : HORIZONTAL  
 Limit : FCC PART 15C PAEK  
 Env. / Ins. : 22.5°C/51.6%  
 Engineer : Donjon\_Huang  
 EUT : Marine Audio System with AM/FM/WB/USB-mpod/Aux in/Bluetooth  
 Power rating : DC 12V  
 Test Mode : 8-DPSK 2480MHz Tx Mode  
 M/N : PA4A

No.	Freq. (MHz)	Ant. Factor (dB/m)	Cable Loss (dB)	AMP factor (dB)	Reading (dBuV)	Emission Level (dBuV/m)	Limits (dBuV/m)	Margin (dB)	Remark
1	2480.000	28.36	5.91	35.70	80.32	78.99	74.00	-4.89	Peak
2	4960.000	33.13	8.72	35.70	45.49	51.94	74.00	22.36	Peak

Remarks: 1. Emission Level= Antenna Factor + Cable Loss + Reading - Amp Factor  
 2. The emission levels that are 20dB below the official limit are not reported.

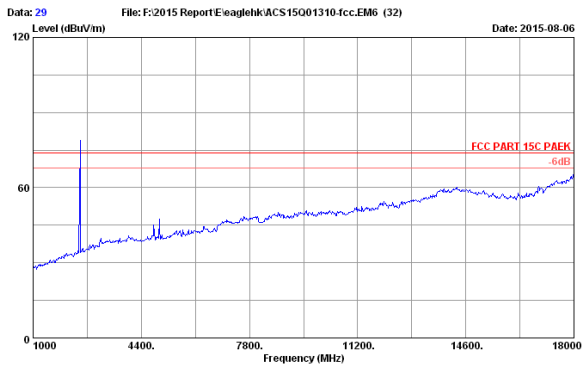

Site no. : 3m Chamber Data no. : 29  
 Dis. / Ant. : 3m 2014 3115 (4580) Ant. pol. : VERTICAL  
 Limit : FCC PART 15C PAEK  
 Env. / Ins. : 22.5°C/51.6%  
 Engineer : Donjon\_Huang  
 EUT : Marine Audio System with AM/FM/WB/USB-mpod/Aux in/Bluetooth  
 Power rating : DC 12V  
 Test Mode : 8-DPSK 2480MHz Tx Mode  
 M/N : PA4A

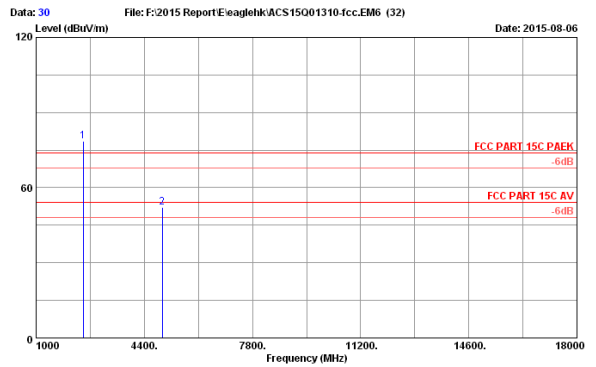

Site no. : 3m Chamber Data no. : 30  
 Dis. / Ant. : 3m 2014 3115 (4580) Ant. pol. : VERTICAL  
 Limit : FCC PART 15C PAEK  
 Env. / Ins. : 22.5°C/51.6%  
 Engineer : Donjon\_Huang  
 EUT : Marine Audio System with AM/FM/WB/USB-mpod/Aux in/Bluetooth  
 Power rating : DC 12V  
 Test Mode : 8-DPSK 2480MHz Tx Mode  
 M/N : PA4A

No.	Freq. (MHz)	Ant. Factor (dB/m)	Cable Loss (dB)	AMP factor (dB)	Reading (dBuV)	Emission Level (dBuV/m)	Limits (dBuV/m)	Margin (dB)	Remark
1	2480.000	28.36	5.91	35.70	80.08	78.65	74.00	-4.65	Peak
2	4960.000	33.13	8.72	35.70	45.92	52.07	74.00	21.93	Peak

Remarks: 1. Emission Level= Antenna Factor + Cable Loss + Reading - Amp Factor  
 2. The emission levels that are 20dB below the official limit are not reported.

## 5. CONDUCTED SPURIOUS EMISSIONS

### 5.1. Test Equipment

Item	Equipment	Manufacturer	Model No.	Serial No.	Last Cal.	Cal. Interval
1.	Spectrum	Agilent	N9030A	MY51380221	Oct.29, 14	1Year
2.	Attenuator (20dB)	Agilent	8491B	MY39262165	Apr. 28,15	1 Year
3.	RF Cable	Hubersuhner	SUCOFLEX102	28620/2	Apr. 28,15	1 Year

### 5.2. Limit

In any 100kHz bandwidth outside the frequency bands in which the spread spectrum intentional radiator is operating, the radio frequency power that is produced by the intentional radiator shall be at least 20dB below that in the 100kHz bandwidth within the band that contains the highest level of the desired power.

### 5.3. Test Procedure

The transmitter output was connected to a spectrum analyzer, The resolution bandwidth is set to 100 kHz, The video bandwidth is set to 300 kHz and measure all the emissions detected.

### 5.4. Test result

**PASS** (The testing data was attached in the next pages.)

**Hopping Off  
GFSK  
2402MHz**

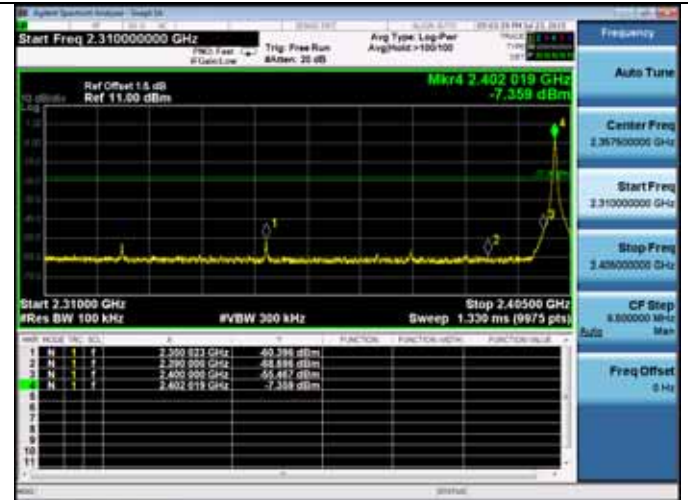
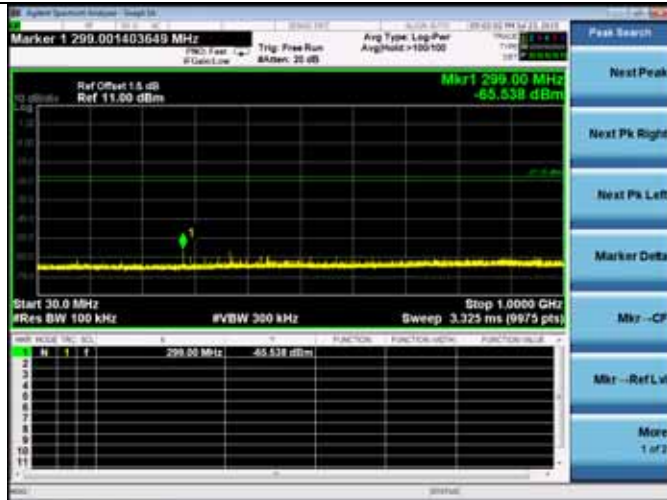

**2441MHz**

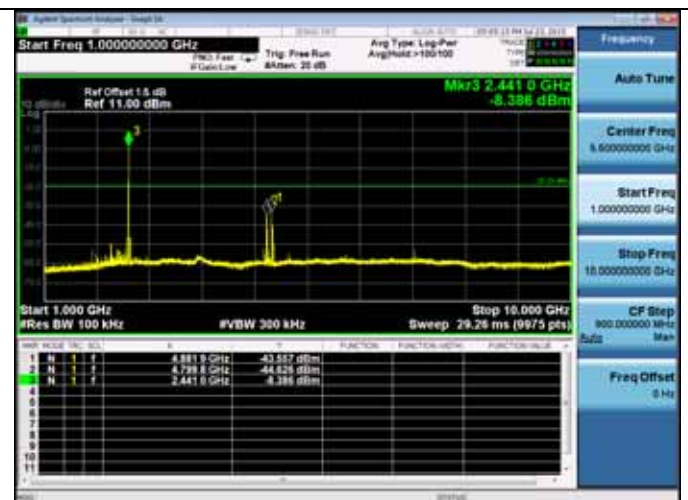
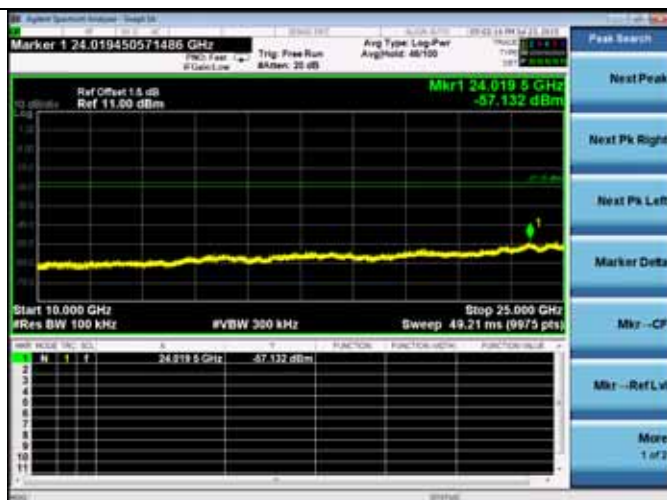
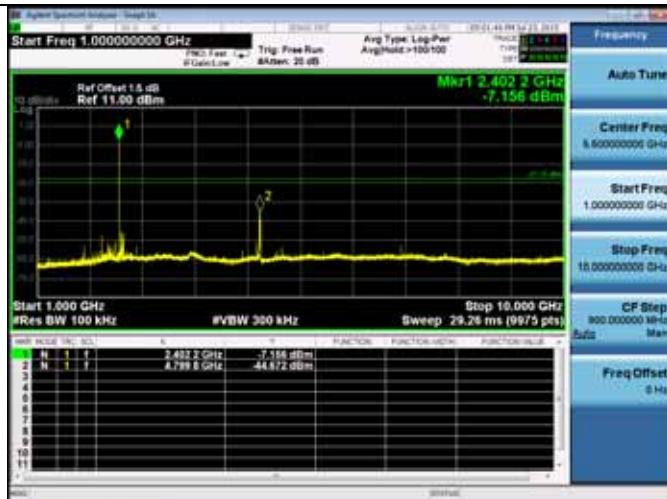

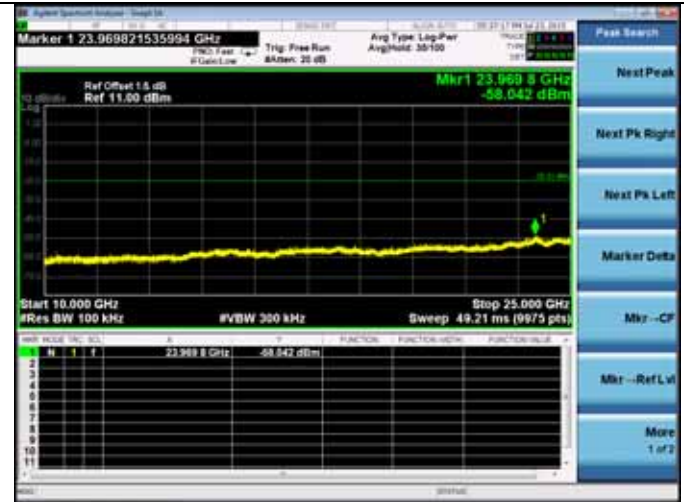

2480MHz

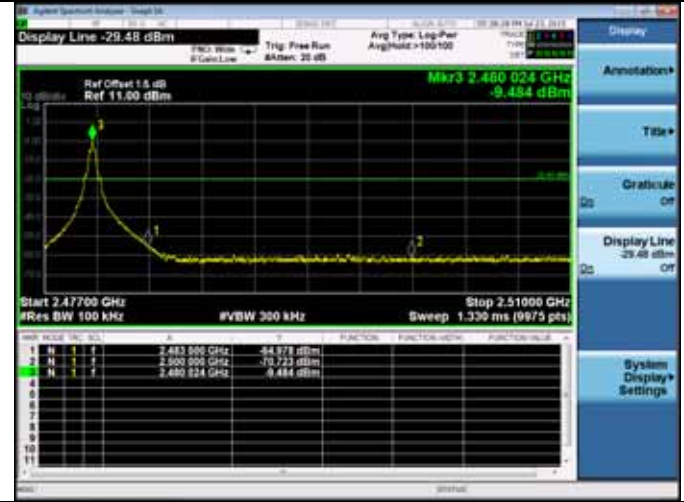
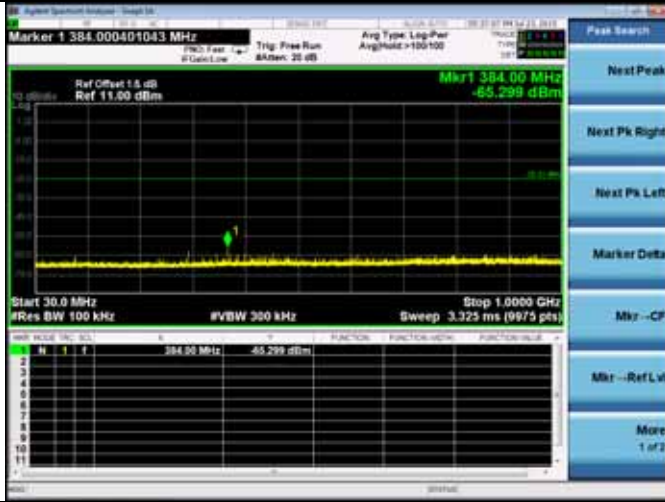

8-DPSK  
2402MHz

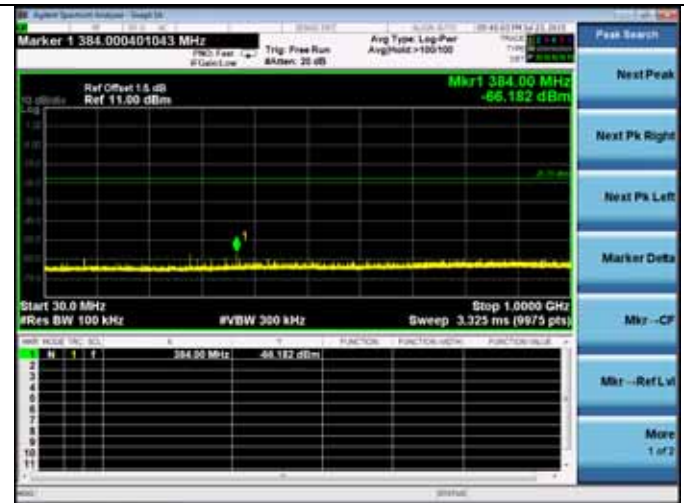
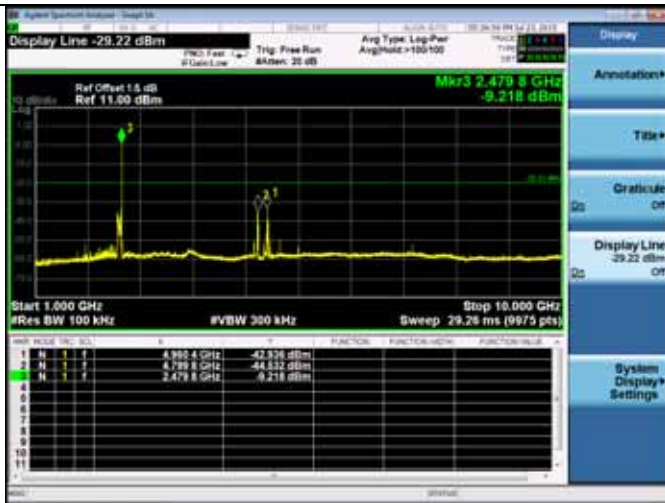

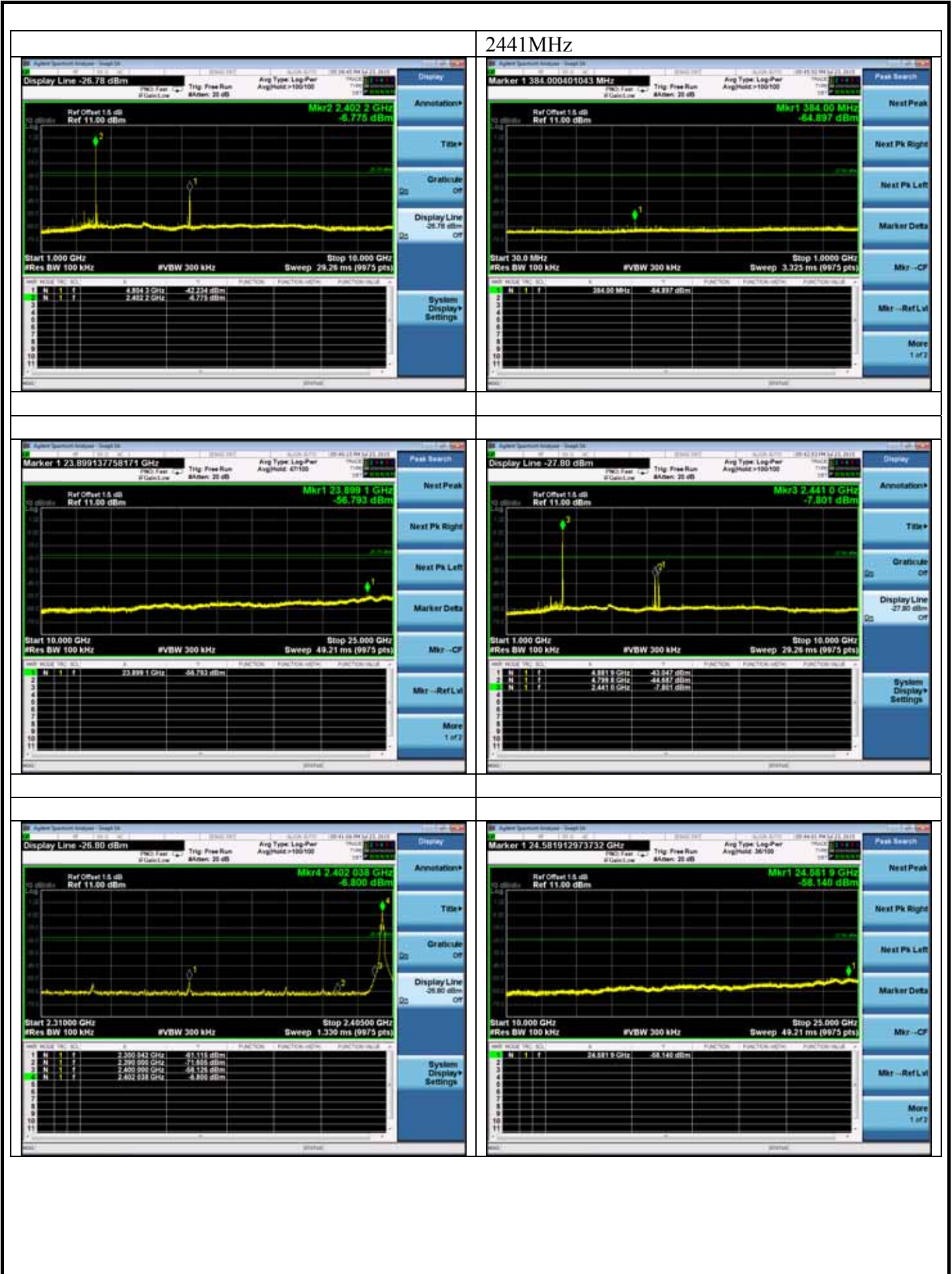



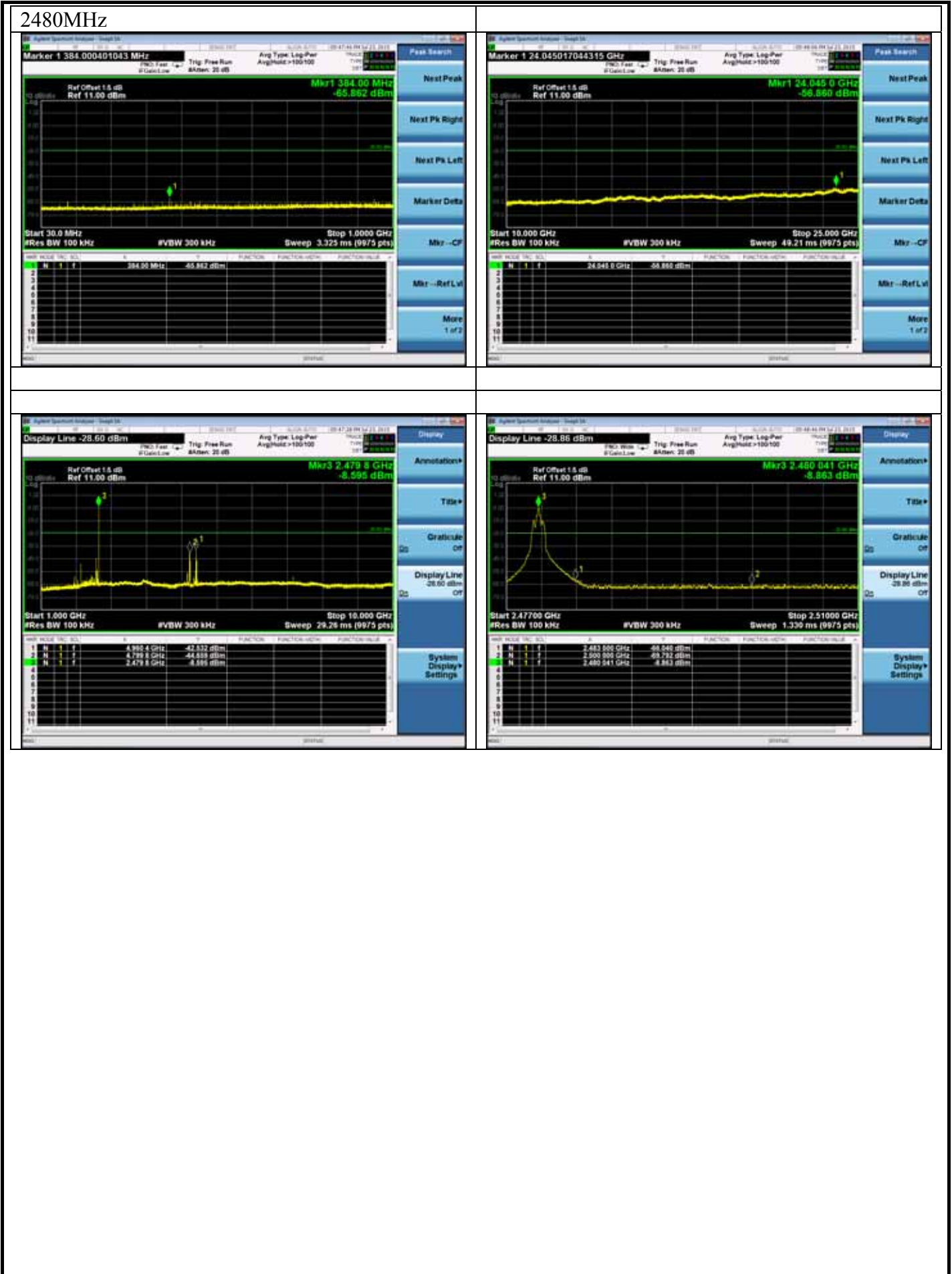

**Hopping On  
GFSK**

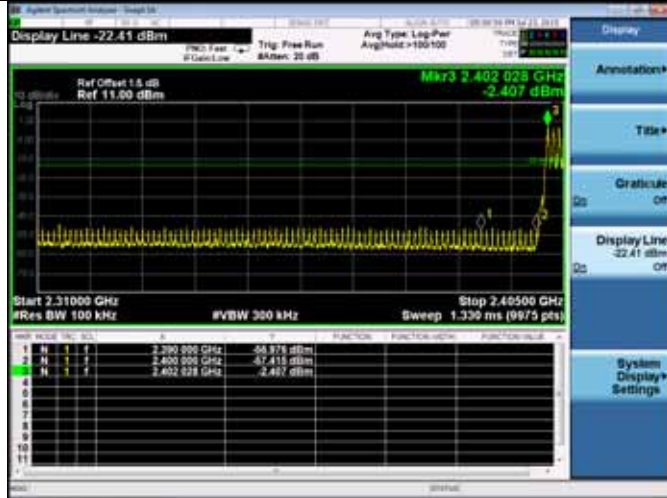

**8-DPSK**

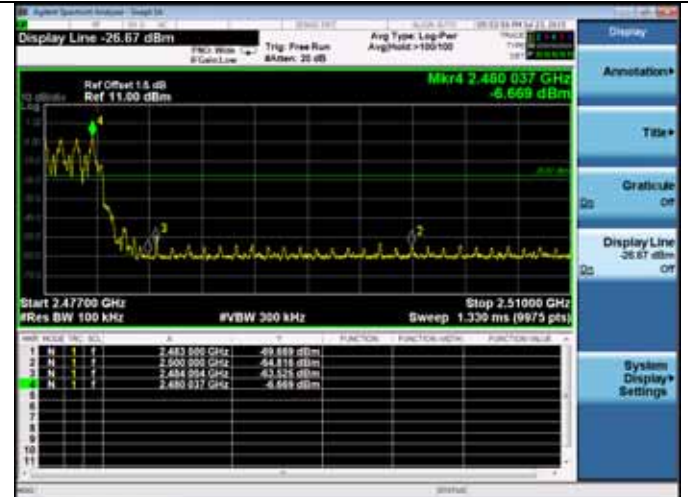
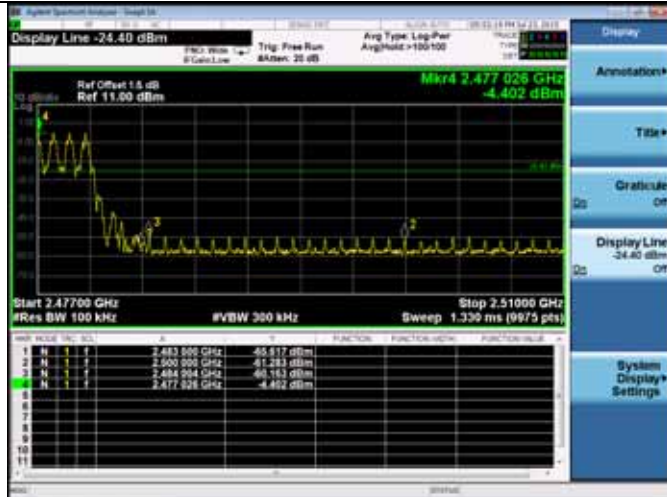
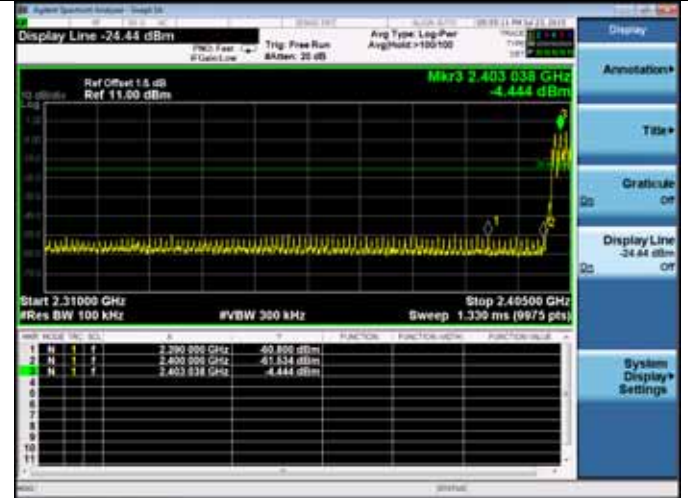

## 6. CARRIER FREQUENCY SEPARATION TEST

### 6.1. Test Equipment

Item	Equipment	Manufacturer	Model No.	Serial No.	Last Cal.	Cal. Interval
1	Spectrum Analyzer	Agilent	N9030A	MY51380221	Oct.29, 14	1Year

### 6.2. Limit

Frequency hopping systems shall have hopping channel carrier frequency separated by a minimum of 25kHz or the 20dB bandwidth of the hopping channel, whichever is greater. Alternatively, frequency hopping systems operating in the 2400-2483.5 MHz band may have hopping channel carrier frequencies that are separated by 25 kHz or two-thirds of the 20 dB bandwidth of the hopping channel, whichever is greater, provided the systems operate with an output power no greater than 125 mW.

### 6.3. Test Results.

EUT: Marine Audio System with AM/FM/WB/USB-ipod/Aux in/Bluetooth		
M/N: PA4A		
Test date: 2015-07-23	Pressure: 101.4±1.0 kpa	Humidity: 51.5±3.0%
Tested by: Donjon_Huang	Test site: RF Site	Temperature: 22.3±0.6

Test Mode	Channel separation	Conclusion
8-DPSK	1.0MHz	PASS
GFSK	1.0MHz	PASS



## 7. 20 DB BANDWIDTH TEST

### 7.1. Test Equipment

Item	Equipment	Manufacturer	Model No.	Serial No.	Last Cal.	Cal. Interval
1.	Spectrum Analyzer	Agilent	N9030A	MY51380221	Oct.29, 14	1Year

### 7.2. Limit

Intentional radiators operating under the alternative provisions to the general emission limits, as contained in §§ 15.217 through 15.257 and in Subpart E of this part, must be designed to ensure that the 20 dB bandwidth of the emission, or whatever bandwidth may otherwise be specified in the specific rule section under which the equipment operates, is contained within the frequency band designated in the rule section under which the equipment is operated.

### 7.3. Test Results

EUT: Marine Audio System with AM/FM/WB/USB-ipod/Aux in/Bluetooth		
M/N: PA4A		
Test date: 2015-08-13	Pressure: 101.4±1.0 kpa	Humidity: 51.5±3.0%
Tested by: Donjon_Huang	Test site: RF Site	Temperature: 22.3±0.6

Test Mode	Frequency ( MHz )	-20dB Bandwidth ( KHz )	Limit (KHz)
GFSK	2402	539.1	N/A
	2441	547.3	N/A
	2480	544.2	N/A
8-DPSK	2402	1148	N/A
	2441	1151	N/A
	2480	1152	N/A

Conclusion : PASS

**GFSK**

Test Frequency: 2402MHz



**8-DPSK**

Test Frequency: 2402MHz



Test Frequency: 2441MHz



Test Frequency: 2441MHz

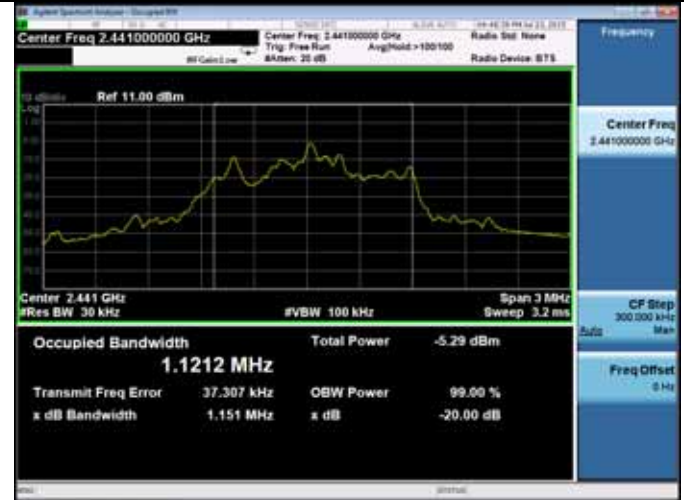

Test Frequency: 2480MHz



Test Frequency: 2480MHz

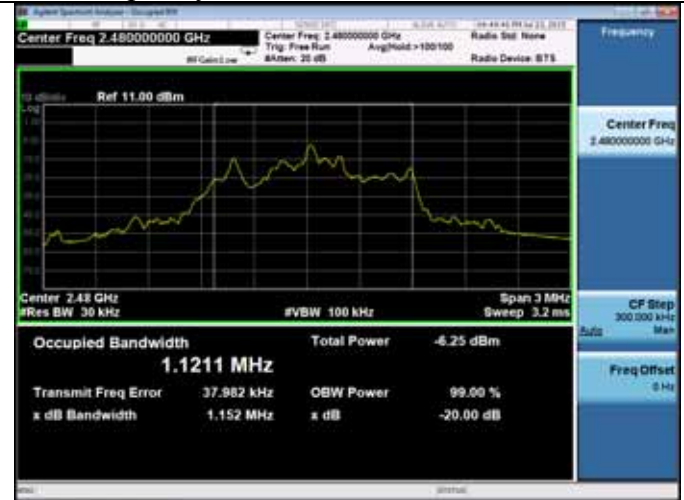

## 8. NUMBER OF HOPPING FREQUENCY TEST

### 8.1. Test Equipment

Item	Equipment	Manufacturer	Model No.	Serial No.	Last Cal.	Cal. Interval
1	Spectrum Analyzer	Agilent	N9030A	MY51380221	Oct.29, 14	1Year

### 8.2. Limit

Frequency hopping systems in the 2400-2483.5 MHz band shall use at least 15 channels

### 8.3. Test Results

EUT: Marine Audio System with AM/FM/WB/USB-ipod/Aux in/Bluetooth		
M/N: PA4A		
Test date: 2015-07-22	Pressure: 101.4±1.0 kpa	Humidity: 51.5±3.0%
Tested by: Donjon_Huang	Test site: RF Site	Temperature: 22.3±0.6

Test Mode	Number of channel	Limit	Conclusion
8-DPSK	79	>=15	PASS
GFSK	79	>=15	PASS



## 9. DWELL TIME

### 9.1. Test Equipment

Item	Equipment	Manufacturer	Model No.	Serial No.	Last Cal.	Cal. Interval
1	Spectrum Analyzer	Agilent	N9030A	MY51380221	Oct.29, 14	1Year

### 9.2. Limit

The average time of occupancy on any channel shall not be greater than 0.4 seconds within a period of 0.4 seconds multiplied by the number of hopping channels employed.

### 9.3. Test Results

EUT: Marine Audio System with AM/FM/WB/USB-ipod/Aux in/Bluetooth		
M/N: PA4A		
Test date: 2015-07-22	Pressure: 101.4±1.0 kpa	Humidity: 51.5±3.0%
Tested by: Donjon_Huang	Test site: RF Site	Temperature: 22.3±0.6

Mode		dwll time	Limit	Conclusion
GFSK	DH1	$47\text{hops}/5\text{s} \times 0.4 \times 79\text{chanel} \times 0.511\text{ms} = 151.787\text{ms}$	<400ms	PASS
	DH3	$26\text{hops}/5\text{s} \times 0.4 \times 79\text{chanel} \times 1.785\text{ms} = 293.311\text{ms}$	<400ms	PASS
	DH5	$15\text{hops}/5\text{s} \times 0.4 \times 79\text{chanel} \times 3.030\text{ms} = 287.244\text{ms}$	<400ms	PASS
8-DPSK	DH1	$49\text{hops}/5\text{s} \times 0.4 \times 79\text{chanel} \times 0.521\text{ms} = 161.343\text{ms}$	<400ms	PASS
	DH3	$26\text{hops}/5\text{s} \times 0.4 \times 79\text{chanel} \times 1.776\text{ms} = 291.832\text{ms}$	<400ms	PASS
	DH5	$14\text{hops}/5\text{s} \times 0.4 \times 79\text{chanel} \times 3.055\text{ms} = 270.306\text{ms}$	<400ms	PASS

Note: All the lower levels were signal from receiver's, and should not considered in here.

**GFSK**  
DH 1

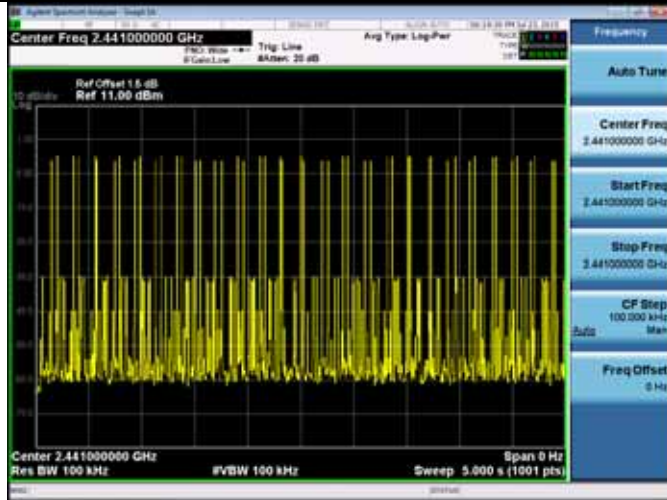

**DH 3**

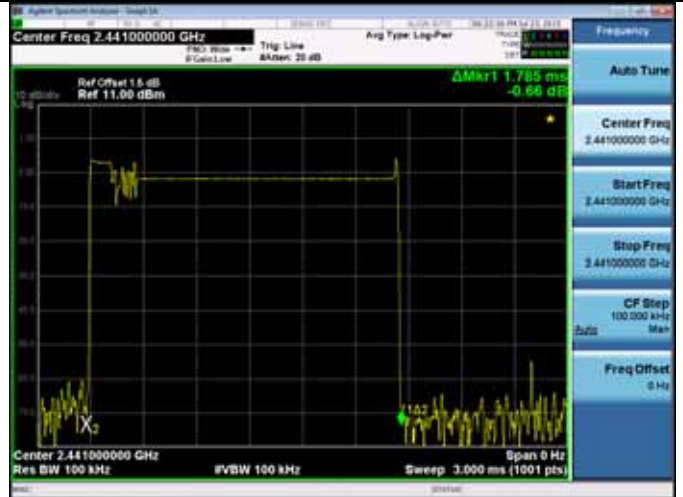
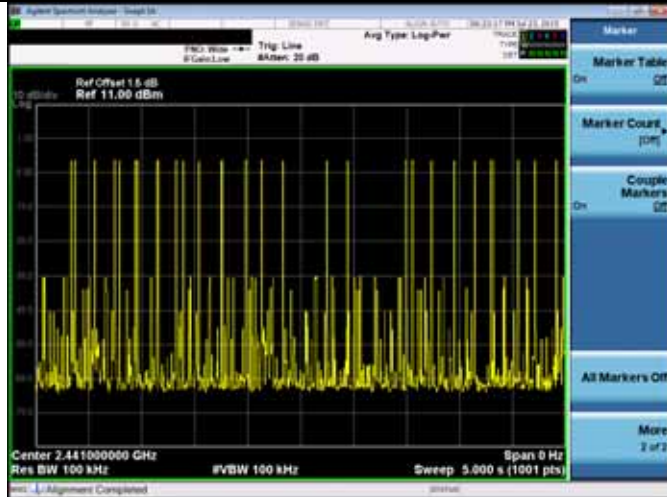

**DH 5**

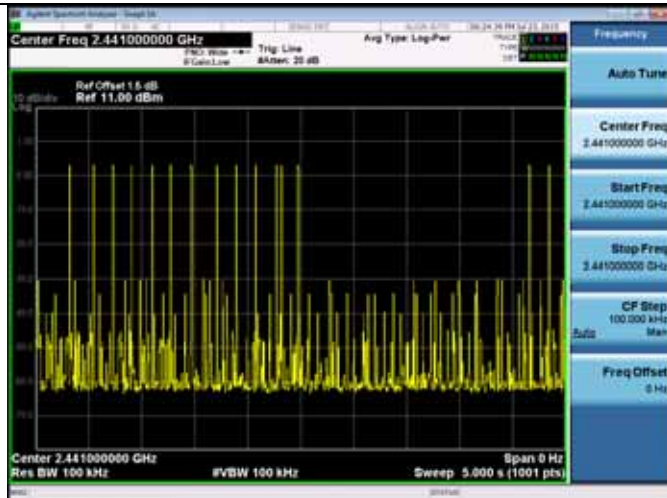



**8-DPSK**  
**3-DH 1**

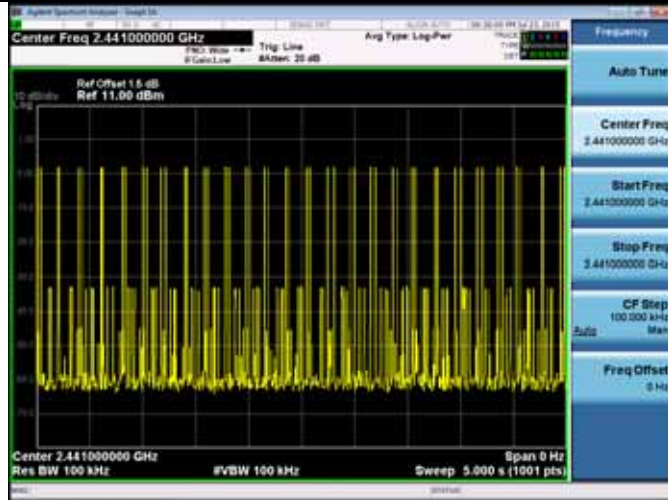

**3-DH 3**

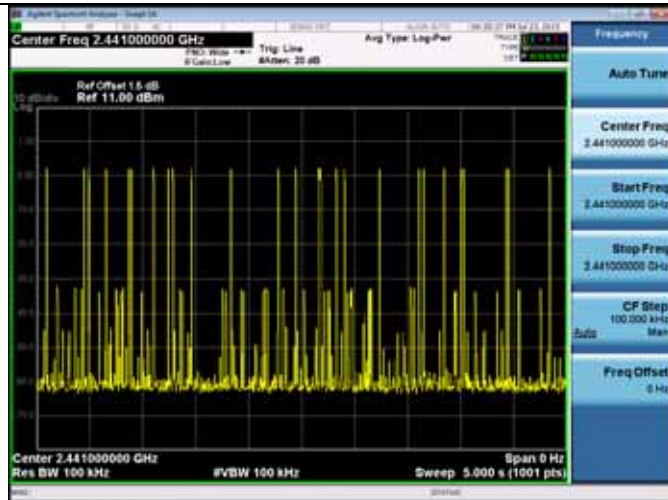

**3-DH 5**

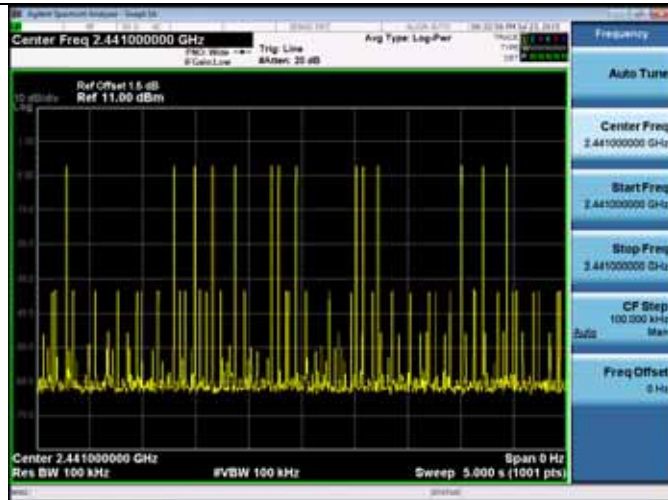

## 10. MAXIMUM PEAK OUTPUT POWER TEST

### 10.1. Test Equipment

Item	Equipment	Manufacturer	Model No.	Serial No.	Last Cal.	Cal. Interval
1.	Spectrum	Agilent	N9030A	MY51380221	Oct.29, 14	1 Year
2.	Power meter	Anritsu	ML2487A	6K00002472	Apr. 28,15	1 Year
3.	Power sensor	Anritsu	MA2491A	0033005	Apr. 28,15	1 Year
4.	Attenuator (20dB)	Agilent	8491B	MY39262165	Apr. 28,15	1 Year
5	RF Cable	Hubersuhner	SUCOFLEX102	28610/2	Apr. 28,15	1 Year

### 10.2. Limit

For frequency hopping systems operating in the 2400-2483.5 MHz band employing at least 75 non-overlapping hopping channels, and all frequency hopping systems in the 5725-5850 MHz band: 1 watt. For all other frequency hopping systems in the 2400-2483.5 MHz band: 0.125 watts.

### 10.3. Test Procedure

The power meter was used to measure for 2400-2483.5MHz band that is the peak output power directly.

### 10.4. Test Results

EUT: Marine Audio System with AM/FM/WB/USB-ipod/Aux in/Bluetooth			
M/N: PA4A			
Test date: 2015-08-13		Pressure: 101.5±1.0 kpa	Humidity: 51.4±1.0%
Tested by: Donjon_Huang		Test site: RF site	Temperature:22.3±1.0
Test Mode	Frequency (MHz)	Peak output Power ( dBm )	Limit (dBm)
GFSK	2402	-6.760	30
	2441	-8.162	30
	2480	-8.964	30
8-DPSK	2402	-5.121	30
	2441	-6.079	30
	2480	-7.237	30
Conclusion: PASS			

## 11. BAND EDGE COMPLIANCE TEST

### 11.1. Test Equipment

Item	Equipment	Manufacturer	Model No.	Serial No.	Last Cal.	Cal. Interval
1.	Amp	HP	8449B	3008A02495	Apr. 28,15	1 Year
2.	Horn Antenna	ETS	3115	9510-4877	Sep.20,14	1 Year
3.	HF Cable	Hubersuhner	Sucoflex104	274094/4	Apr. 28,15	1 Year
4.	RF Cable	Hubersuhner	Sucoflex102	28610/2	Apr. 28,15	1 Year

### 11.2. Limit

All the lower and upper band-edges emissions appearing within 2310MHz to 2390MHz and 2483.5MHz to 2500MHz restricted frequency bands shall not exceed the limits shown in 15.209, all the other emissions outside operation frequency band 2400MHz to 2483.5MHz shall be at least 20dB below the fundamental emissions, or comply with 15.209 limits.

### 11.3. Test Produce

For upper band emissions that are up to two bandwidths(2MHz) away (2483.5MHz to 2485.5MHz ) from the band-edge use below produce:

1. Choose a spectrum analyzer span that encompasses both the peak of the fundamental emission and the band-edge emission under investigation. Set the analyzer RBW to 100KHz and with a video bandwidth 300KHz. Record the peak levels of the fundamental emission and the relevant band-edge emission, Observe the stored trace and measure the amplitude delta between the peak of the fundamental and the peak of the band-edge emission. This is not a field strength measurement, it is only a relative measurement to determine the amount by which the emission drops at the band edge relative to the highest fundamental emission level.
2. Subtract the delta measured in step (1) from the maximum field strengths measured in clause 4 .The resultant field strengths are then used to determine band-edge compliance as required by Section 15.205

For emissions above two bandwidths away from the band-edge use below produce:

1. The EUT is placed on a turntable, which is 0.8m above the ground plane and worked at highest radiated power.
2. The turntable was rotated for 360 degrees to determine the position of maximum emission level.
3. EUT is set 3m away from the receiving antenna, which is varied from 1m to 4m to find out the highest emission.
4. Set the spectrum analyzer in the following setting in order to capture the lower and upperband-edges of the emission:
  - (a) PEAK: RBW=1MHz ;VBW=3MHz, PK detector, Sweep=AUTO
  - (b) This is pulse Modulation device a duty cycle factor was used to calculate average level based measured peak level.

### 11.4. Test Results

Pass (The testing data was attached in the next pages.)

Note: If the PK measured levels comply with average limit, then the average level were deemed to comply with average limit.

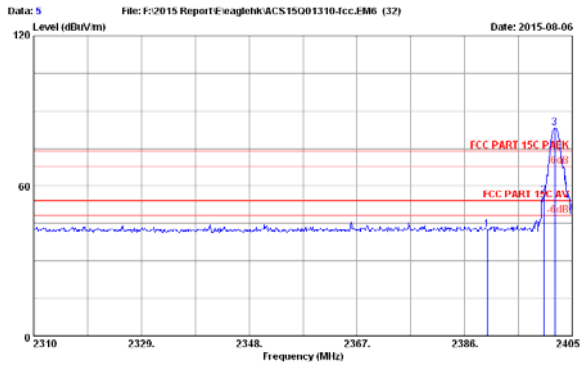

Site no. : 3m Chamber Data no. : 5  
 Dis. / Ant. : 3m 2014 3115 (4500) Ant. pol. : HORIZONTAL  
 Limit : FCC PART 15C PAKK  
 Env. / Ins. : 22.5°C/51.6°  
 Engineer : Donjon\_Huang  
 EUT : Marine Audio System with AM/FM/VD/USB-ipod/Aux in/Bluetooth  
 Power rating : DC 12V  
 Test Mode : OFSK 2402MHz Tx Mode  
 N/N : PA4A

No.	Freq. (MHz)	Ant. Factor (dB/m)	Cable Loss (dB)	AMP factor (dB)	Reading (dBUV)	Emission Level (dBUV/m)	Limits (dBUV/m)	Margin (dB)	Remark
1	2390.000	20.16	5.70	35.70	44.20	42.44	74.00	31.56	Peak
2	2400.000	28.18	5.80	35.70	57.72	56.00	74.00	18.00	Peak
3	2401.960	28.18	5.80	35.70	85.02	83.30	74.00	-9.30	Peak

Remarks: 1. Emission Level= Antenna Factor + Cable Loss + Reading - Amp Factor  
 2. The emission levels that are 20dB below the official limit are not reported.

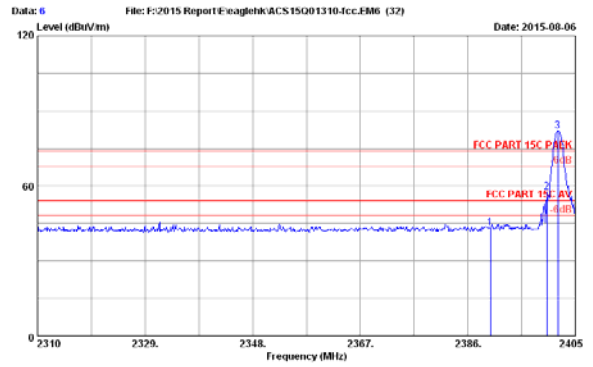

Site no. : 3m Chamber Data no. : 6  
 Dis. / Ant. : 3m 2014 3115 (4500) Ant. pol. : VERTICAL  
 Limit : FCC PART 15C PAKK  
 Env. / Ins. : 22.5°C/51.6°  
 Engineer : Donjon\_Huang  
 EUT : Marine Audio System with AM/FM/VD/USB-ipod/Aux in/Bluetooth  
 Power rating : DC 12V  
 Test Mode : OFSK 2402MHz Tx Mode  
 N/N : PA4A

No.	Freq. (MHz)	Ant. Factor (dB/m)	Cable Loss (dB)	AMP factor (dB)	Reading (dBUV)	Emission Level (dBUV/m)	Limits (dBUV/m)	Margin (dB)	Remark
1	2390.000	20.16	5.70	35.70	44.97	40.21	74.00	30.79	Peak
2	2400.000	28.18	5.80	35.70	59.26	57.54	74.00	16.46	Peak
3	2401.960	28.18	5.80	35.70	83.65	81.93	74.00	-7.93	Peak

Remarks: 1. Emission Level= Antenna Factor + Cable Loss + Reading - Amp Factor  
 2. The emission levels that are 20dB below the official limit are not reported.

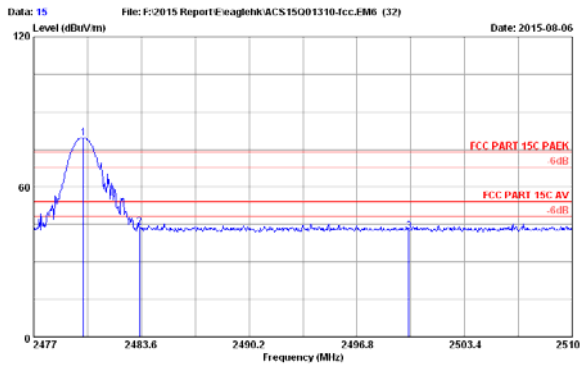

Site no. : 3m Chamber Data no. : 15  
 Dis. / Ant. : 3m 2014 3115 (4500) Ant. pol. : HORIZONTAL  
 Limit : FCC PART 15C PAKK  
 Env. / Ins. : 22.5°C/51.6°  
 Engineer : Donjon\_Huang  
 EUT : Marine Audio System with AM/FM/VD/USB-ipod/Aux in/Bluetooth  
 Power rating : DC 12V  
 Test Mode : OFSK 2480MHz Tx Mode  
 N/N : PA4A

No.	Freq. (MHz)	Ant. Factor (dB/m)	Cable Loss (dB)	AMP factor (dB)	Reading (dBUV)	Emission Level (dBUV/m)	Limits (dBUV/m)	Margin (dB)	Remark
1	2400.069	20.36	5.91	35.70	01.10	79.70	74.00	-5.70	Peak
2	2483.500	28.36	5.92	35.70	45.16	43.74	74.00	30.26	Peak
3	2500.000	28.40	5.94	35.70	49.64	42.28	74.00	31.72	Peak

Remarks: 1. Emission Level= Antenna Factor + Cable Loss + Reading - Amp Factor  
 2. The emission levels that are 20dB below the official limit are not reported.

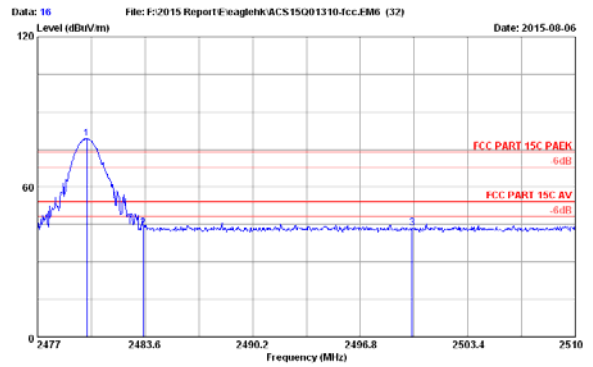

Site no. : 3m Chamber Data no. : 16  
 Dis. / Ant. : 3m 2014 3115 (4500) Ant. pol. : VERTICAL  
 Limit : FCC PART 15C PAKK  
 Env. / Ins. : 22.5°C/51.6°  
 Engineer : Donjon\_Huang  
 EUT : Marine Audio System with AM/FM/VD/USB-ipod/Aux in/Bluetooth  
 Power rating : DC 12V  
 Test Mode : OFSK 2480MHz Tx Mode  
 N/N : PA4A

No.	Freq. (MHz)	Ant. Factor (dB/m)	Cable Loss (dB)	AMP factor (dB)	Reading (dBUV)	Emission Level (dBUV/m)	Limits (dBUV/m)	Margin (dB)	Remark
1	2400.026	20.36	5.91	35.70	00.64	79.21	74.00	-5.21	Peak
2	2483.500	28.36	5.92	35.70	44.91	43.49	74.00	30.51	Peak
3	2500.000	28.40	5.94	35.70	44.68	43.32	74.00	30.68	Peak

Remarks: 1. Emission Level= Antenna Factor + Cable Loss + Reading - Amp Factor  
 2. The emission levels that are 20dB below the official limit are not reported.

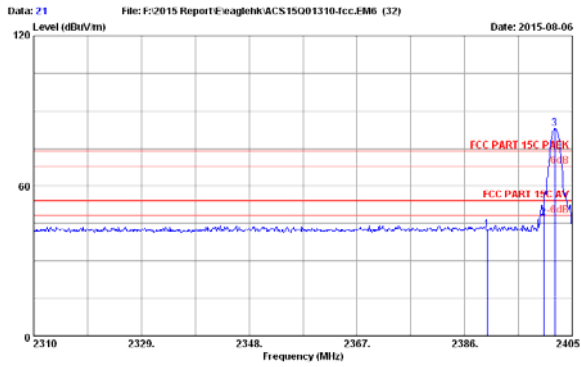

Site no. : 3m Chamber Data no. : 21  
 Dis. / Ant. : 3m 2014 3115 (4500) Ant. pol. : HORIZONTAL  
 Limit : FCC PART 15C PAEK  
 Env. / Ins. : 22.5°C/51.6A  
 Engineer : Donjon\_Huang  
 EUT : Marine Audio System with AM/FM/WB/USB-ipod/Aux in/Bluetooth  
 Power rating : DC 12V  
 Test Mode : 8-DPSK 2402MHz Tx Mode  
 M/N : PA4A

No.	Freq. (MHz)	Ant. Factor (dB/m)	Cable Loss (dB)	AMP factor (dB)	Reading (dBuV)	Emission Level (dBuV/m)	Limits (dBuV/m)	Margin (dB)	Remark
1	2090.000	20.16	5.70	35.70	44.06	42.30	74.00	31.70	Peak
2	2400.000	28.18	5.80	35.70	48.78	47.06	74.00	26.94	Peak
3	2401.960	28.18	5.80	35.70	84.76	83.04	74.00	-9.04	Peak

Remarks: 1. Emission Level= Antenna Factor + Cable Loss + Reading - Amp Factor  
 2. The emission levels that are 20dB below the official limit are not reported.

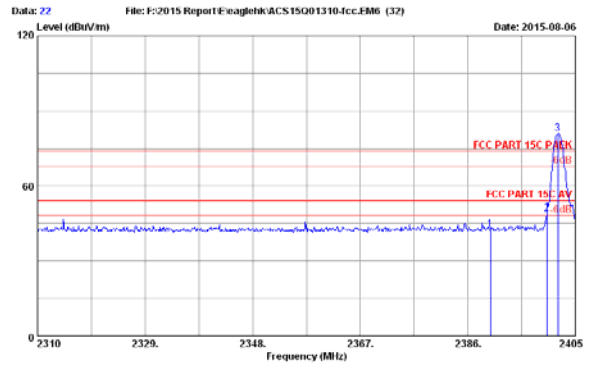

Site no. : 3m Chamber Data no. : 22  
 Dis. / Ant. : 3m 2014 3115 (4500) Ant. pol. : VERTICAL  
 Limit : FCC PART 15C PAEK  
 Env. / Ins. : 22.5°C/51.6A  
 Engineer : Donjon\_Huang  
 EUT : Marine Audio System with AM/FM/WB/USB-ipod/Aux in/Bluetooth  
 Power rating : DC 12V  
 Test Mode : 8-DPSK 2402MHz Tx Mode  
 M/N : PA4A

No.	Freq. (MHz)	Ant. Factor (dB/m)	Cable Loss (dB)	AMP factor (dB)	Reading (dBuV)	Emission Level (dBuV/m)	Limits (dBuV/m)	Margin (dB)	Remark
1	2390.000	20.16	5.70	35.70	44.15	42.39	74.00	31.61	Peak
2	2400.000	28.18	5.80	35.70	50.44	48.72	74.00	25.28	Peak
3	2401.960	28.18	5.80	35.70	82.57	80.85	74.00	-6.85	Peak

Remarks: 1. Emission Level= Antenna Factor + Cable Loss + Reading - Amp Factor  
 2. The emission levels that are 20dB below the official limit are not reported.

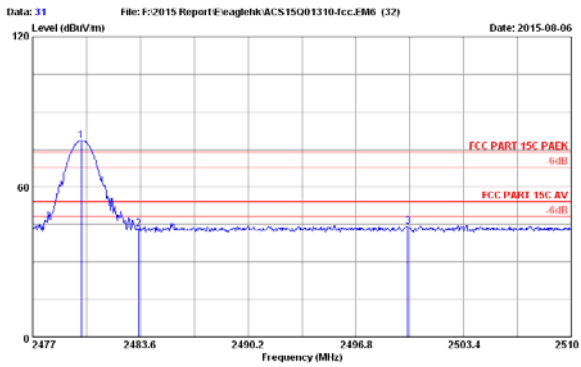

Site no. : 3m Chamber Data no. : 31  
 Dis. / Ant. : 3m 2014 3115 (4500) Ant. pol. : HORIZONTAL  
 Limit : FCC PART 15C PAEK  
 Env. / Ins. : 22.5°C/51.6A  
 Engineer : Donjon\_Huang  
 EUT : Marine Audio System with AM/FM/WB/USB-ipod/Aux in/Bluetooth  
 Power rating : DC 12V  
 Test Mode : 8-DPSK 2480MHz Tx Mode  
 M/N : PA4A

No.	Freq. (MHz)	Ant. Factor (dB/m)	Cable Loss (dB)	AMP factor (dB)	Reading (dBuV)	Emission Level (dBuV/m)	Limits (dBuV/m)	Margin (dB)	Remark
1	2479.970	20.26	5.91	35.70	00.07	70.64	74.00	-4.64	Peak
2	2483.500	28.36	5.92	35.70	44.37	42.95	74.00	31.05	Peak
3	2500.000	28.40	5.94	35.70	45.37	44.01	74.00	29.99	Peak

Remarks: 1. Emission Level= Antenna Factor + Cable Loss + Reading - Amp Factor  
 2. The emission levels that are 20dB below the official limit are not reported.

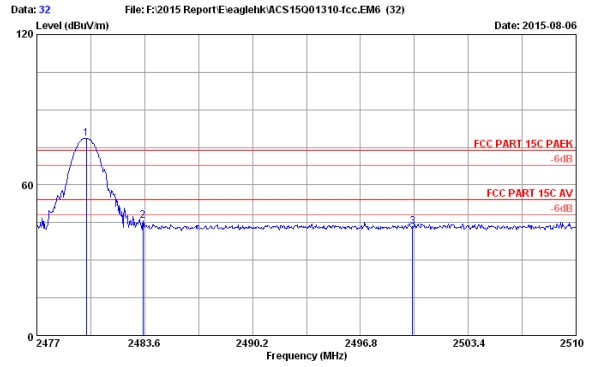

Site no. : 3m Chamber Data no. : 32  
 Dis. / Ant. : 3m 2014 3115 (4580) Ant. pol. : VERTICAL  
 Limit : FCC PART 15C PAEK  
 Env. / Ins. : 22.5°C/51.6A  
 Engineer : Donjon\_Huang  
 EUT : Marine Audio System with AM/FM/WB/USB-ipod/Aux in/Bluetooth  
 Power rating : DC 12V  
 Test Mode : 8-DPSK 2480MHz Tx Mode  
 M/N : PA4A

No.	Freq. (MHz)	Ant. Factor (dB/m)	Cable Loss (dB)	AMP factor (dB)	Reading (dBuV)	Emission Level (dBuV/m)	Limits (dBuV/m)	Margin (dB)	Remark
1	2480.036	28.36	5.91	35.70	80.13	78.70	74.00	-4.70	Peak
2	2483.500	28.36	5.92	35.70	47.18	45.76	74.00	28.24	Peak
3	2500.000	28.40	5.94	35.70	44.80	43.44	74.00	30.56	Peak

Remarks: 1. Emission Level= Antenna Factor + Cable Loss + Reading - Amp Factor  
 2. The emission levels that are 20dB below the official limit are not reported.

## 12.DEVIATION TO TEST SPECIFICATIONS

[NONE]