



**FCC PART 15C TEST REPORT FOR CERTIFICATION
On Behalf of**

Sounding Audio Industrial Ltd

Car Stereo/Video with AM/FM/WXA/DVD/USB/BT

Model Number: JWM990

FCC ID: OPDJWM990

Prepared for : Sounding Audio Industrial Ltd
Unit G, 7/F, Stage 2, Wah Fung Industrial, Centre 33-39
Kwai Fung Road, Kwai Chung, Hong Kong

Prepared By : Audix Technology (Shenzhen) Co., Ltd.
No. 6, Ke Feng Rd., 52 Block,
Shenzhen Science & Industrial Park,
Nantou, Shenzhen, Guangdong, China

Tel: (0755) 26639496

Report Number : ACS-F14222
Date of Test : Jun.20~Jul.10, 2014
Date of Report : Jul.14, 2014

TABLE OF CONTENTS

<u>Description</u>	<u>Page</u>
1. SUMMARY OF STANDARDS AND RESULTS	1-1
1.1. Description of Standards and Results.....	1-1
2. GENERAL INFORMATION.....	2-1
2.1. Description of Device (EUT)	2-1
2.2. Test information	2-2
2.3. Tested Supporting System Details	2-2
2.4. Block Diagram of Test Setup.....	2-3
2.5. Test Facility.....	2-4
2.6. Measurement Uncertainty (95% confidence levels, k=2)	2-4
3. POWER LINE CONDUCTED EMISSION MEASUREMENT.....	3-1
4. RADIATED EMISSION MEASUREMENT	4-1
4.1. Test Equipment	4-1
4.2. Block Diagram of Test Setup.....	4-1
4.3. Radiated Emission Limit Standard: FCC 15.209	4-2
4.4. EUT Configuration on Test.....	4-2
4.5. Operating Condition of EUT.....	4-3
4.6. Test Procedure.....	4-3
4.7. Radiated Emission Test Results	4-3
5. CONDUCTED SPURIOUS EMISSIONS	5-1
5.1. Test Equipment	5-1
5.2. Limit.....	5-1
5.3. Test Procedure.....	5-1
5.4. Test result	5-1
6. CARRIER FREQUENCY SEPARATION TEST	6-1
6.1. Test Equipment	6-1
6.2. Limit.....	6-1
6.3. Test Results.....	6-1
7. 20 DB BANDWIDTH TEST	7-1
7.1. Test Equipment	7-1
7.2. Limit.....	7-1
7.3. Test Results	7-1
8. NUMBER OF HOPPING FREQUENCY TEST	8-1
8.1. Test Equipment	8-1
8.2. Limit.....	8-1
8.3. Test Results	8-1
9. DWELL TIME.....	9-1
9.1. Test Equipment	9-1
9.2. Limit.....	9-1
9.3. Test Results	9-1
10. MAXIMUM PEAK OUTPUT POWER TEST.....	10-1
10.1. Test Equipment	10-1
10.2. Limit.....	10-1
10.3. Test Procedure.....	10-1
10.4. Test Results	10-1

11.	BAND EDGE COMPLIANCE TEST	11-1
11.1.	Test Equipment	11-1
11.2.	Limit.....	11-1
11.3.	Test Produce	11-1
11.4.	Test Results	11-2
12.	DEVIATION TO TEST SPECIFICATIONS	12-1
13.	PHOTOGRAPH OF TEST.....	13-1
13.1.	Photos of Radiated Emission Test (30-1000MHz).....	13-1
14.	PHOTOS OF THE EUT	14-1

TEST REPORT CERTIFICATION

Applicant : Sounding Audio Industrial Ltd
Manufacturer : Eagle Plastic Development Co., Ltd.
EUT Description : Car Stereo/Video with AM/FM/WXA/DVD/USB/BT
FCC ID : OPDJWM990
(A) MODEL NO. : JWM990
(B) Serial No. : N/A
(C) POWER SUPPLY : DC 12V
(D) TEST VOLTAGE : DC 12V

Tested for comply with:
FCC Rules and Regulations Part 15 Subpart C: 2013
Test procedure used:
ANSI C63.10: 2009

The device described above is tested by AUDIX TECHNOLOGY (SHENZHEN) CO., LTD. to confirm comply with all the FCC Part 15 Subpart C requirements. The test results are contained in this test report and AUDIX TECHNOLOGY (SHENZHEN) CO., LTD. is assumed full responsibility for the accuracy and completeness of these tests. Also, this report shows that the Equipment Under Test (EUT) is to be technically compliant with the FCC and IC requirements. This report contains data that are not covered by the NVLAP accreditation.

This Report is made under FCC Part 2.1075. No modifications were required during testing to bring this product into compliance.

This report applies to above tested sample only. This report shall not be reproduced in part without written approval of AUDIX TECHNOLOGY (SHENZHEN) CO., LTD.

The report must not be used by the client to claim product certification, approval, or endorsement by NVLAP, NIST, or any agency of the federal government.

Date of Test : Jun.20~Jul.10, 2014 Report of date: Jul.14, 2014

Prepared by : Sonia Lee Reviewed by : Sunny Lu
Sonia Lee / Assistant Sunny Lu / Assistant Manager

Approved & Authorized Signer : _____



David Jin / Manager

1. SUMMARY OF STANDARDS AND RESULTS

1.1. Description of Standards and Results

The EUT have been tested according to the applicable standards as referenced below.

EMISSION		
Description of Test Item	Standard	Results
Power Line Conducted Emission Test	FCC Part 15: 15.207 ANSI C63.10 :2009	N/A
Radiated Emission Test	FCC Part 15: 15.209 FCC Part 15: 15.247(d) ANSI C63.10 :2009	PASS
Conducted Spurious Emissions	FCC Part 15: 15.247(a)(1) ANSI C63.10 :2009	PASS
Carrier Frequency Separation Test	FCC Part 15: 15.247(a)(1) ANSI C63.10 :2009	PASS
20dB Bandwidth Test	FCC Part 15: 15.215 ANSI C63.10 :2009	PASS
Number Of Hopping Frequency Test	FCC Part 15: 15.247(a)(1)(iii) ANSI C63.10 :2009	PASS
Dwell Time Test	FCC Part 15: 15.247(a)(1)(iii) ANSI C63.10 :2009	PASS
Maximum Peak Output Power Test	FCC Part 15: 15.247(b)(1)\ ANSI C63.10 :2009	PASS
Band Edge Compliance Test	FCC Part 15: 15.247(d) ANSI C63.10 :2009	PASS

2. GENERAL INFORMATION

2.1. Description of Device (EUT)

EUT name	: Car Stereo/Video with AM/FM/WXA/DVD/USB/BT
Model Number	: JWM990
Radio	: Bluetooth V3.0
Operation frequency	: 2402-2480MHz
Channel Number	: 79 channels
Modulation Technology	: GFSK
Antenna Type	: F type PCB mount 3dBi
Applicant	: Sounding Audio Industrial Ltd Unit G, 7/F, Stage 2, Wah Fung Industrial, Centre 33-39 Kwai Fung Road, Kwai Chung, Hong Kong
Manufacturer	: Eagle Plastic Development Co., Ltd. Sima District, Changping, Dongguan, Guangdong
Remote	: Manufacturer: JENSEN, M/N: CR2025
Date of Test	: Jun.20~Jul.10, 2014
Date of Receipt	: Jun.19, 2014
Sample Type	: Prototype production

2.2. Test information

The test software “bluesuite.exe” was used to control EUT work in Continuous TX mode, and select test channel.

Tested mode, channel, and data rate information			
Mode	data rate (Mbps)	Channel	Frequency (MHz)
Tx Mode GFSK modulation	1	Low :CH 0	2402
	1	Middle: CH39	2441
	1	High: CH78	2480

2.3. Tested Supporting System Details

No.	Description	ACS No.	Manufacturer	Model	Serial Number	Approved type
1.	Speaker 1#	ACS-EMC-SP01TB	QINLE	QL618	N/A	<input checked="" type="checkbox"/> FCC DoC <input type="checkbox"/> BSMI ID
		B-R/B-L Cable: Shielded, Undetectable, 0.9m				
2.	Speaker 2#	ACS-EMC-SP02TB	QINLE	QL618	N/A	<input checked="" type="checkbox"/> FCC DoC <input type="checkbox"/> BSMI ID
		B-R/B-L Cable: Shielded, Undetectable, 0.9m				
3.	DVD Player	ACS-EMC-DVD01	DENON	DVD-3910	4098400342E	<input type="checkbox"/> FCC ID <input type="checkbox"/> BSMI ID
		AUX IN Cable: Shielded, Detachable, 1.8m Power Cord: Unshielded, Detachable, 1.8m COXS Cable: Shielded, Detachable, 1.8m HDMI Cable: Shielded, Detachable, 1.2m Optical Cable: Shielded, Detachable, 1.2m				
4.	MP3 Player	N/A	Sony	MWZ-B172F	N/A	N/A
5.	USB Disk	N/A	Kingston	4G Mini Memory		
6.	iPod	ACS-EMC-IP01	APPLE	A1199	YM706MLDVQ5	<input checked="" type="checkbox"/> FCC DoC <input checked="" type="checkbox"/> BSMI ID: R33057
		AUX Cable:Shielded, Detachable, 1.0m				

2.4. Block Diagram of Test Setup

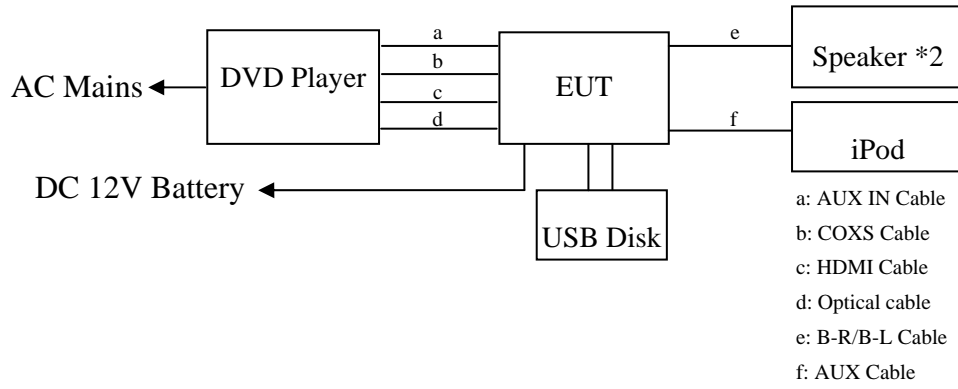

(EUT: Car Stereo/Video with AM/FM/WXA/DVD/USB/BT)

2.5. Test Facility

Site Description

Name of Firm : Audix Technology (Shenzhen) Co., Ltd.
 No. 6, Ke Feng Rd., 52 Block, Shenzhen
 Science & Industrial Park, Nantou, Shenzhen,
 Guangdong, China

3m Anechoic Chamber : Certificated by FCC, USA
 Registration Number: 90454
 Valid Date: Feb.22, 2015

3m & 10m Anechoic Chamber : Certificated by FCC, USA
 Registration Number: 794232
 Valid Date: Oct.31, 2015

EMC Lab. : Certificated by Industry Canada
 Registration Number: IC 5183A-1
 Valid Date: Jun.13, 2014

: Certificated by DAkkS, Germany
 Registration No: D-PL-12151-01-00
 Valid Date: Dec.15, 2016

: Accredited by NVLAP, USA
 NVLAP Code: 200372-0
 Valid Date: Mar.31, 2015

2.6. Measurement Uncertainty (95% confidence levels, k=2)

Test Item	Uncertainty	Memo
Uncertainty for Radiated Emission test in 3m chamber	±3.22 dB	30~200MHz, Polarization: H
	±3.23 dB	30~200MHz, Polarization: V
	±3.49 dB	200M~1GHz, Polarization: H
	±3.39 dB	200M~1GHz, Polarization: V
Uncertainty for Radiated Emission test in 3m chamber (1GHz-18GHz)	±4.97 dB	1~6GHz, Distance: 3m
	±4.99 dB	6~18GHz, Distance: 3m
Uncertainty for Radiated Spurious Emission test	±3.57 dB	
Uncertainty for Conducted Spurious emission test	±2.00 dB	
Uncertainty for Output power test	±0.73 dB	
Uncertainty for Power density test	±2.00 dB	
Uncertainty for Temperature and humidity test for ETSI	±3%	
	±0.6°C	
Uncertainty for Radio Frequency	±7x10 ⁻⁸	
Uncertainty for Bandwidth	±83 KHz	
RF level uncertainty for given BER	±0.2 dB	

3. POWER LINE CONDUCTED EMISSION MEASUREMENT

According to Paragraph (c) of FCC Part 15 section 15.07, Tests to demonstrate compliance with the conducted limits are not required for devices which only employ battery power for operation and which do not operate from the AC power lines or contain provisions for operation while connected to the AC power lines.

4. RADIATED EMISSION MEASUREMENT

4.1. Test Equipment

Frequency rang: 30~1000MHz (In 3m Anechoic Chamber)

Item	Equipment	Manufacturer	Model No.	Serial No.	Last Cal.	Cal. Interval
1.	3#Chamber	AUDIX	N/A	N/A	Nov.24, 13	1 Year
2.	EMI Spectrum	Agilent	E4407B	MY41440292	Apr. 28,14	1 Year
3.	Test Receiver	Rohde & Schwarz	ESVS10	834468/011	Apr. 28,14	1 Year
4.	Amplifier	HP	8447D	2648A04738	Apr. 28,14	1 Year
5.	Bilog Antenna	Schaffner	CBL6111C	2598	Apr. 08,14	1 Year
6.	RF Cable	MIYAZAKI	CFD400-NL	3# Chamber No.1	Apr. 28,14	1 Year
7.	Coaxial Switch	Anritsu	MP59B	M74389	Apr. 28,14	1 Year

4.1.1. For frequency range 1GHz~25GHz (In 3m Anechoic Chamber)

Item	Equipment	Manufacturer	Model No.	Serial No.	Last Cal.	Cal. Interval
1	Spectrum Analyzer	Agilent	E4446A	US44300459	Apr. 28,14	1 Year
2	Horn Antenna	EMCO	3115	9607-4877	Aug.27, 13	1 Year
3	Amplifier	Agilent	8449B	3008A02495	Apr. 28,14	1 Year
4	RF Cable	Hubersuhner	SUCOFLEX106	77977/6	Apr. 28,14	1 Year
5	RF Cable	Hubersuhner	SUCOFLEX106	28616/2	Apr. 28,14	1 Year
6	Horn Antenna	EMCO	3116	00060089	Aug.27, 13	1 Year

4.2. Block Diagram of Test Setup

For frequency range 30MHz-1000MHz

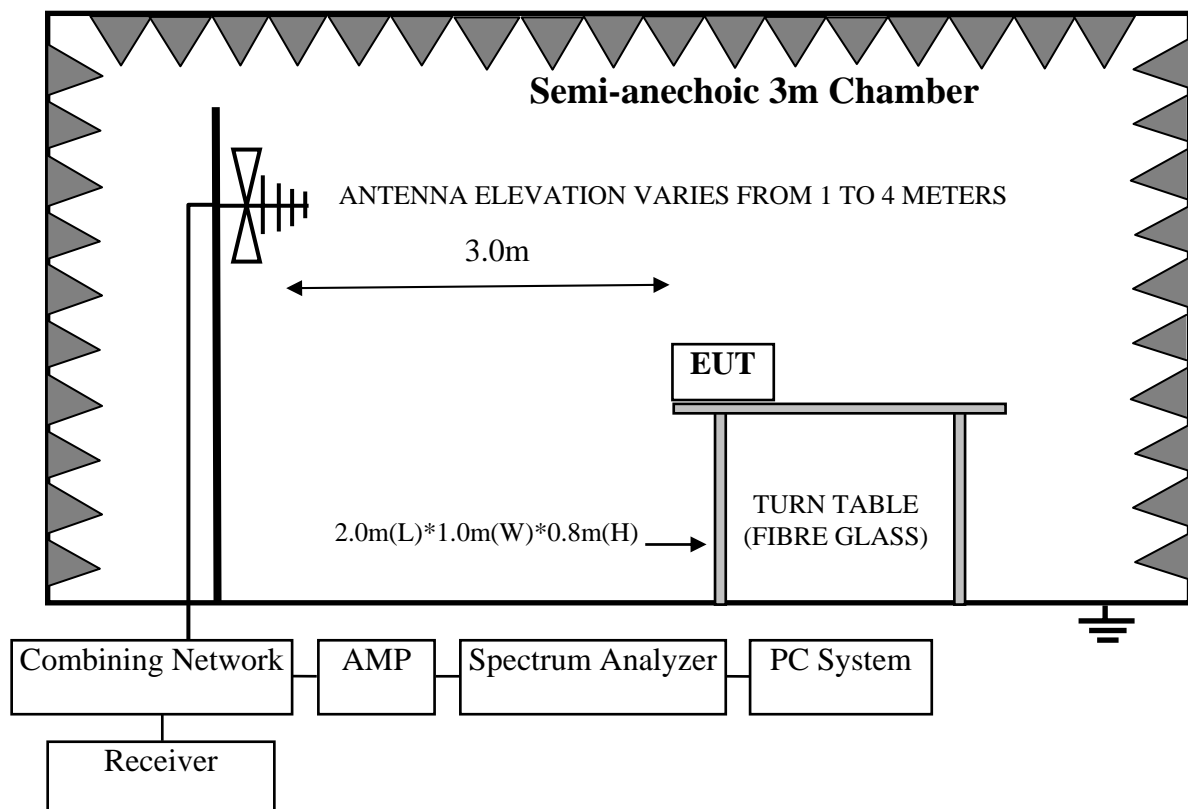

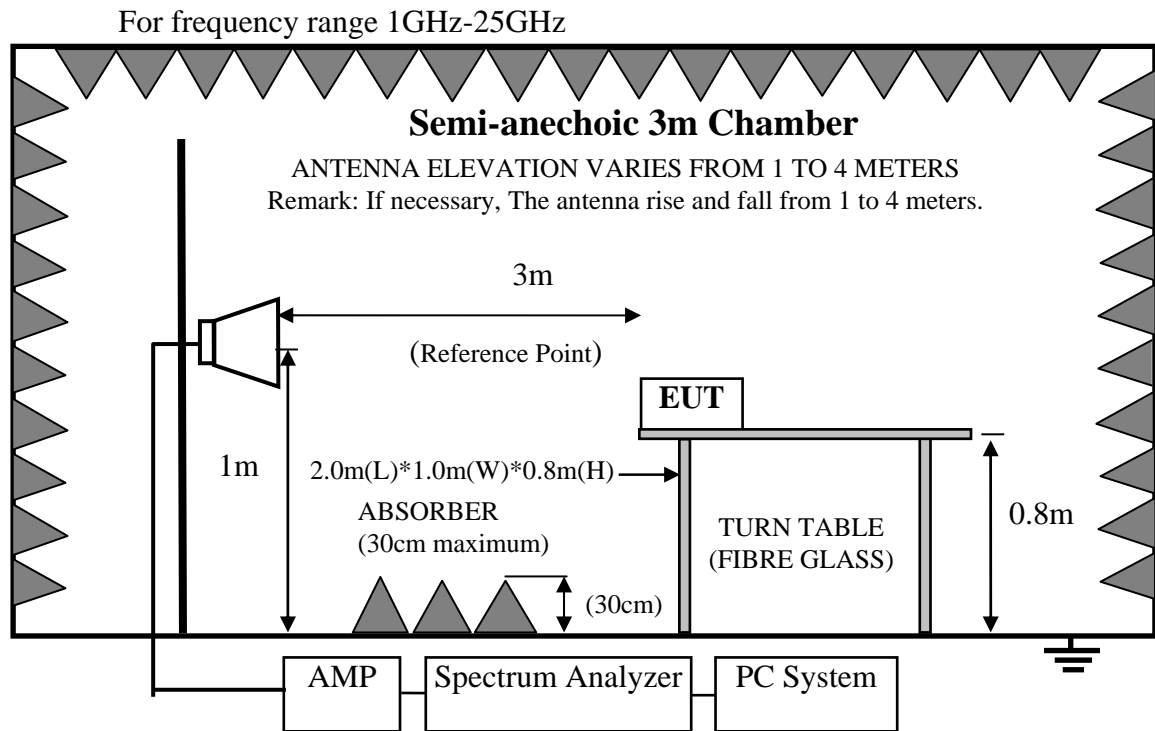

4.3. Radiated Emission Limit Standard: FCC 15.209

FREQUENCY MHz	DISTANCE Meters	FIELD STRENGTHS LIMIT	
		µV/m	dB(µV)/m
30 ~ 88	3	100	40.0
88 ~ 216	3	150	43.5
216 ~ 960	3	200	46.0
960 ~ 1000	3	500	54.0
Above 1000MHz	3	74.0 dB(µV)/m (Peak) 54.0 dB(µV)/m (Average)	

Remark : (1) Emission level dBµV = 20 log Emission level µV/m

- (2) The smaller limit shall apply at the cross point between two frequency bands.
- (3) Distance is the distance in meters between the measuring instrument, antenna and the closest point of any part of the device or system.
- (4) The emission limits shown in the above table are based on measurements employing a CISPR quasi-peak detector except for the frequency bands 9-90 kHz, 110-490 kHz and above 1000 MHz. Radiated emission limits in these three bands are based on measurements employing an average detector.

4.4.EUT Configuration on Test

The following equipment are installed on Radiated Emission Test to meet the commission requirements and operating regulations in a manner which tends to maximize its emission characteristics in normal application.

4.4.1. Car Stereo/Video with AM/FM/WXA/DVD/USB/BT (EUT)

Model Number : JWM990
 Serial Number : N/A

4.5. Operating Condition of EUT

4.5.1. Setup the EUT and simulator as shown as Section 4.2.

4.5.2. Turned on the power of all equipment.

4.5.3. Let EUT work in Tx mode.

4.6. Test Procedure

The EUT and its simulators are placed on a turn table, which is 0.8 meter high above ground. The turn table can rotate 360 degrees to determine the position of the maximum emission level. The EUT is set 3 meters away from the receiving antenna, which is mounted on a antenna tower. The antenna can be moved up and down between 1 meter and 4 meters to find out the maximum emission level. Broadband antenna (calibrated bilog antenna) is used as receiving antenna. Both horizontal and vertical polarization of the antenna is set on Test. In order to find the maximum emission levels, all of the interface cables must be manipulated according to ANSI C63.10-2009 on radiated emission Test.

This test was performed with EUT in X, Y, Z position, and the worse case was found when EUT in X position as the test photo indicated.

The bandwidth of the EMI test receiver (R&S ESVS10) is set at 120kHz for frequency range from 30MHz to 1000 MHz.

The bandwidth of the Spectrum's RBW is set at 1MHz and VBW is set at 3MHz for peak emissions measurement above 1GHz

This device is pulse Modulated, a duty cycle factor was used to calculated average level based measured peak level.

The frequency range from 30MHz to 10th harmonic (25GHz) are checked. and no any emissions were found from 18GHz to 25 GHz, So the radiated emissions from 18GHz to 25GHz were not record.

4.7. Radiated Emission Test Results

PASS.

All the emissions from 30MHz to 25GHz were comply with the 15.209 Limit.

Note: The duty cycle factor for calculate average level is -30.54dB, and average limit is 20dB below peak limit, so if peak measured level comply with average limit, the average level was deemed to comply with average limit.

Duty cycle correct factor= $20\log(\text{dwell time}/100\text{ms})=-30.54\text{dB}$

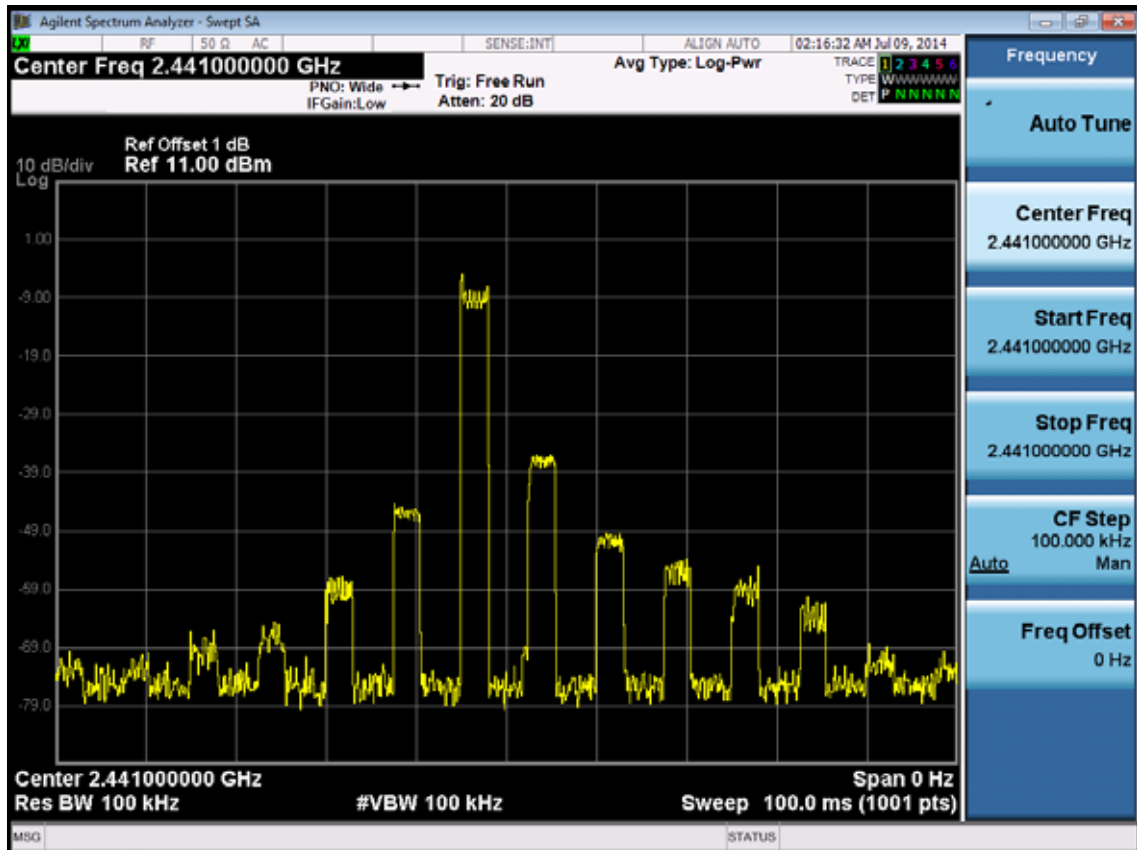
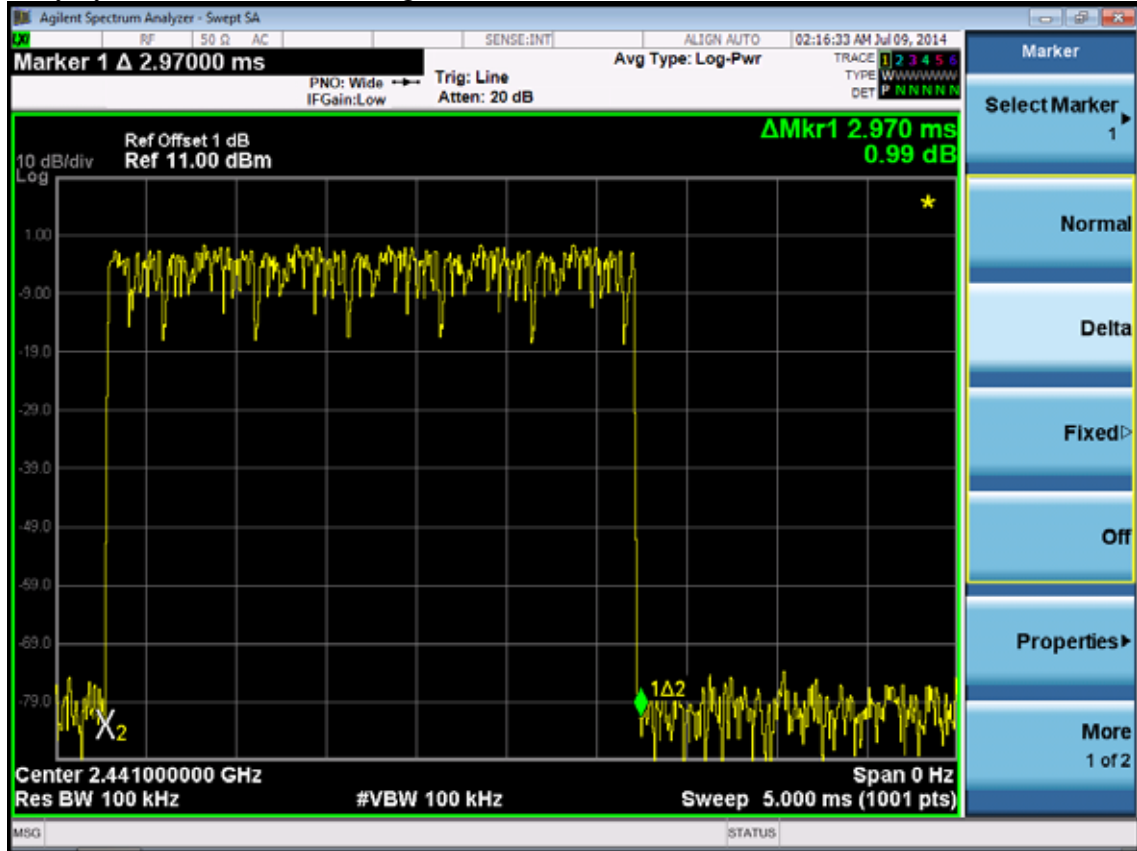

Frequency: 30MHz~1GHz

Data: 9 File: G:\2014 Report\S\SOUNDING\ACS14Q1061.EM6 (9)

Date: 2014-06-20

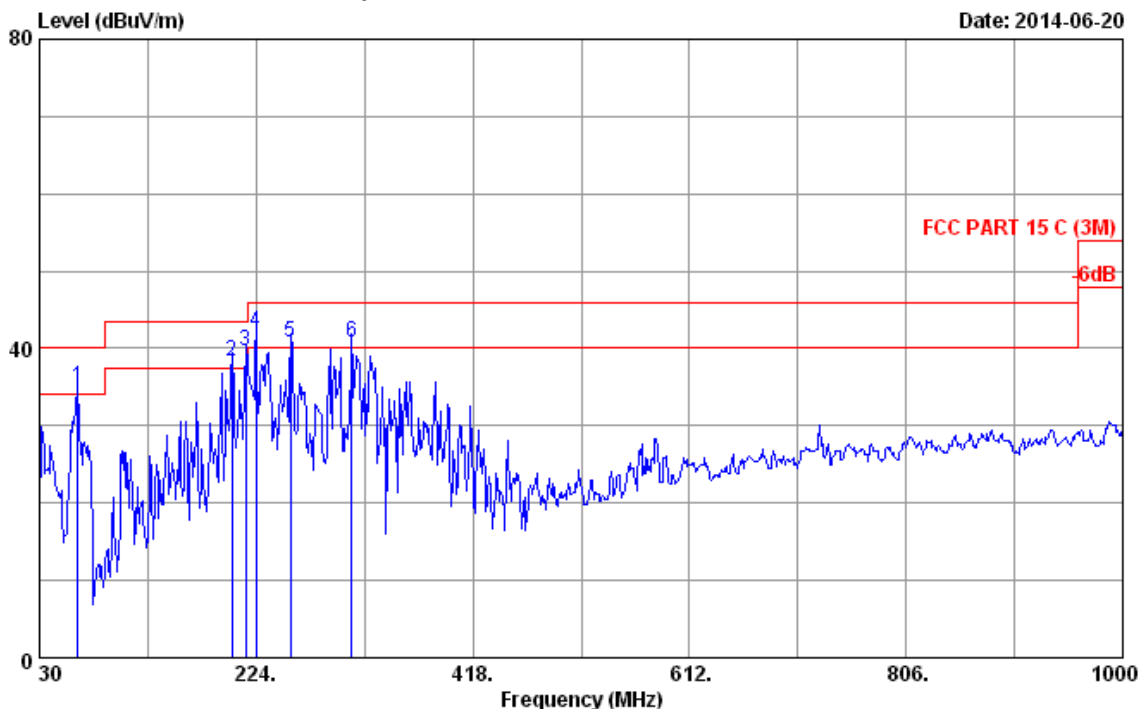

Site no. : 3m Chamber Data no. : 9
 Dis. / Ant. : 3m 2014 CBL6111C 2598 Ant. pol. : HORIZONTAL
 Limit : FCC PART 15 B (3M)
 Env. / Ins. : 23.2*C/47% Engineer : Even_Deng
 EUT : Car Stereo/Video with AM/FM/WXA/DVD/USB/BT
 Power rating : DC 12V
 Test Mode : Tx Mode
 M/N:JWM990

No.	Freq. (MHz)	Ant. Factor (dB/m)	Cable Loss (dB)	Reading (dBuV)	Emission Level (dBuV/m)	Limits (dBuV/m)	Margin (dB)	Remark
1	63.95	5.20	0.89	28.87	34.96	40.00	5.04	QP
2	202.66	10.37	1.86	26.18	38.41	43.50	5.09	QP
3	214.30	10.00	1.91	27.67	39.58	43.50	3.92	QP
4	224.00	10.70	1.96	29.49	42.15	46.00	3.85	QP
5	255.04	13.30	2.10	25.43	40.83	46.00	5.17	QP
6	309.36	13.80	2.33	24.65	40.78	46.00	5.22	QP

Remarks: 1. Emission Level= Antenna Factor + Cable Loss + Reading.
 2. The emission levels that are 20dB below the official limit are not reported.

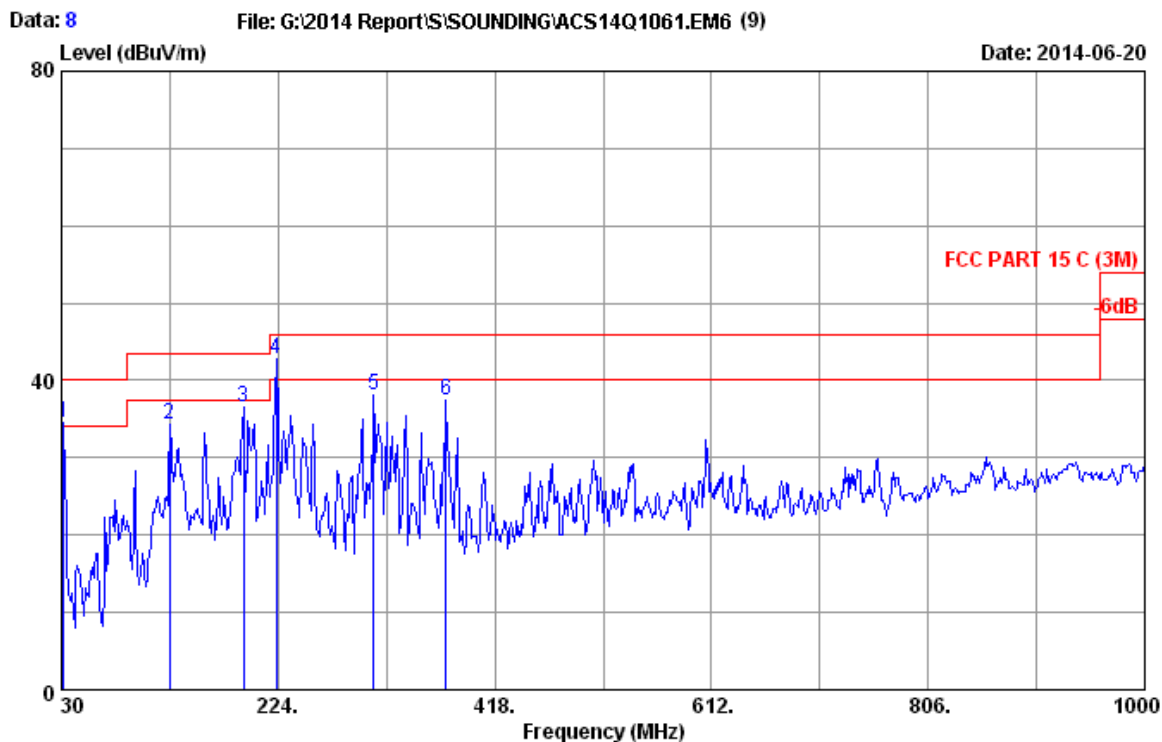

Site no. : 3m Chamber Data no. : 8
 Dis. / Ant. : 3m 2014 CBL6111C 2598 Ant. pol. : VERTICAL
 Limit : FCC PART 15 B (3M)
 Env. / Ins. : 23.2*C/47% Engineer : Even_Deng
 EUT : Car Stereo/Video with AM/FM/WXA/DVD/USB/BT
 Power rating : DC 12V
 Test Mode : Tx Mode
 M/N:JWM990

No.	Freq. (MHz)	Ant. Factor (dB/m)	Cable Loss (dB)	Reading (dBuV)	Emission Level (dBuV/m)	Limits (dBuV/m)	Margin (dB)	Remark
1	31.94	19.91	0.62	14.01	34.54	40.00	5.46	QP
2	127.00	12.60	1.36	20.47	34.43	43.50	9.07	QP
3	192.96	9.70	1.80	25.15	36.65	43.50	6.85	QP
4	222.06	10.51	1.95	30.28	42.74	46.00	3.26	QP
5	309.36	13.80	2.33	21.88	38.01	46.00	7.99	QP
6	374.35	15.79	2.68	19.05	37.52	46.00	8.48	QP

Remarks: 1. Emission Level= Antenna Factor + Cable Loss + Reading.
 2. The emission levels that are 20dB below the official limit are not reported.

Frequency: 1GHz~18GHz

Data: 1 File: G:\2014 Report\SI\SOUNDING\ACS14Q1061.EM6 (16) Date: 2014-07-06

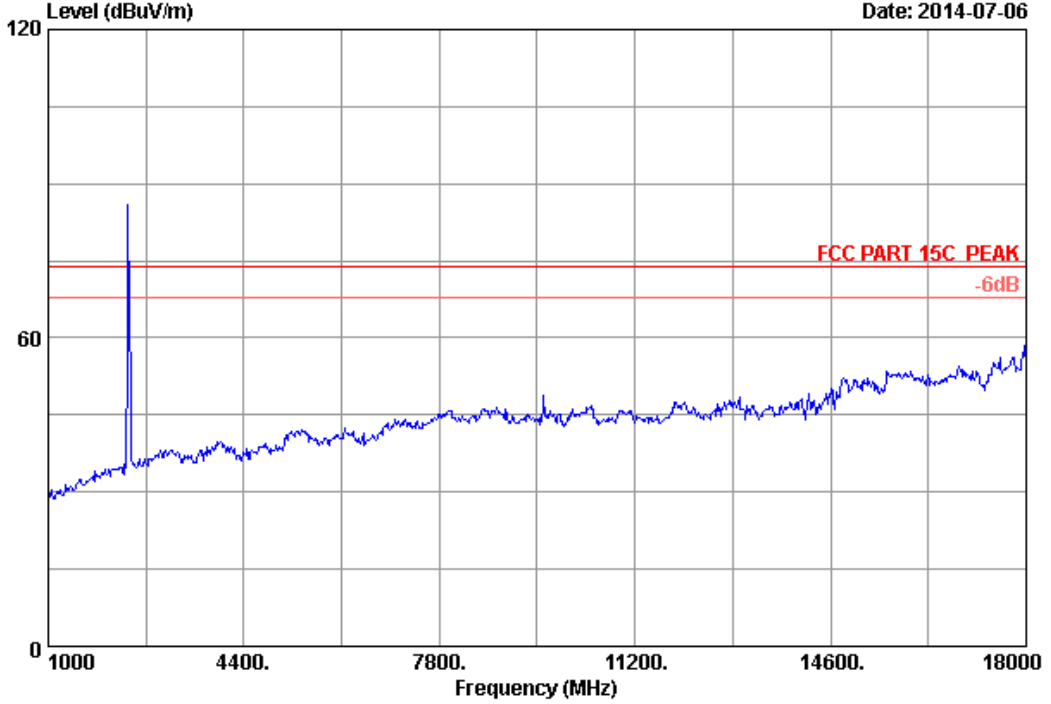

Site no. : 10m Chamber Data no. : 1
Dis. / Ant. : 3m 2013 3115 (4580) Ant. pol. : HORIZONTAL
Limit : FCC PART 15C PEAK
Env. / Ins. : 24*C/56% Engineer : Eric
EUT : Car Stereo/Video with AM/FM/WXA/DVD/USB/BT
Power rating : DC 3V
Test Mode : GFSK 2402MHz Tx
JWM990

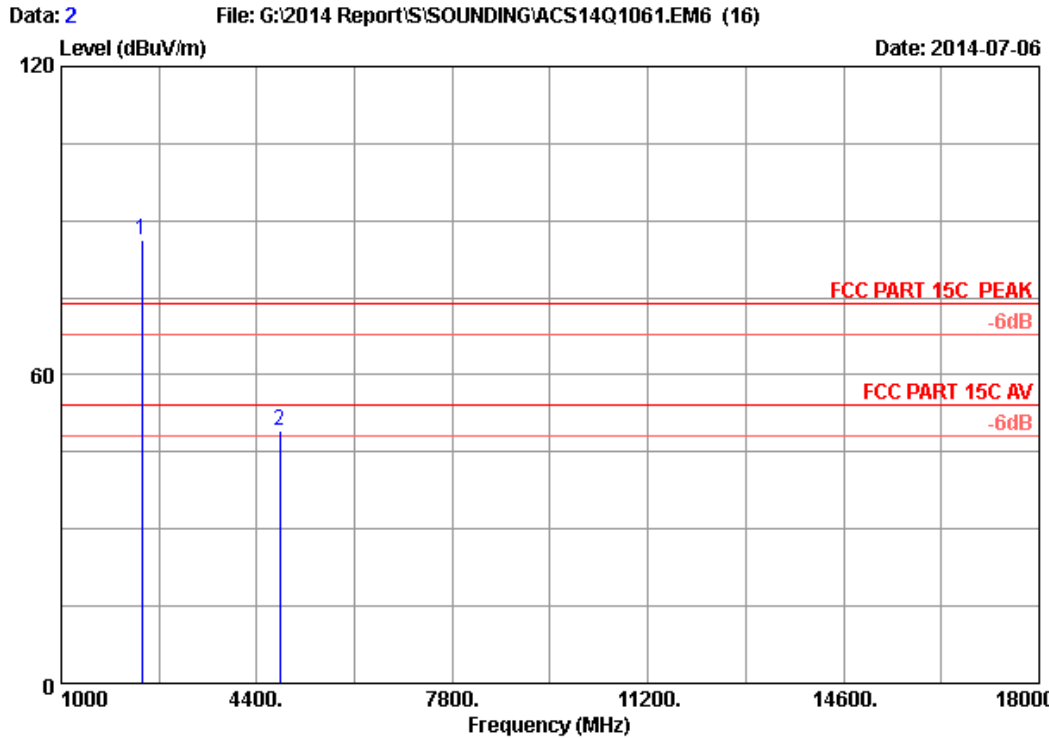

Site no. : 10m Chamber Data no. : 2
 Dis. / Ant. : 3m 2013 3115 (4580) Ant. pol. : HORIZONTAL
 Limit : FCC PART 15C PEAK
 Env. / Ins. : 24*C/56% Engineer : Eric
 EUT : Car Stereo/Video with AM/FM/WXA/DVD/USB/BT
 Power rating : DC 3V
 Test Mode : GFSK 2402MHz Tx
 JWM990

No.	Freq. (MHz)	Ant. Factor (dB/m)	Cable Loss (dB)	Reading (dBUV)	Emission Level (dBUV/m)	Limits (dBUV/m)	Margin (dB)	Remark
1	2402.000	28.18	6.43	87.22	86.13	74.00	-12.13	Peak
2	4804.000	32.85	8.96	43.16	49.27	74.00	24.73	Peak

Remarks: 1. Emission Level= Antenna Factor + Cable Loss + Reading.
 2. The emission levels that are 20dB below the official limit are not reported.

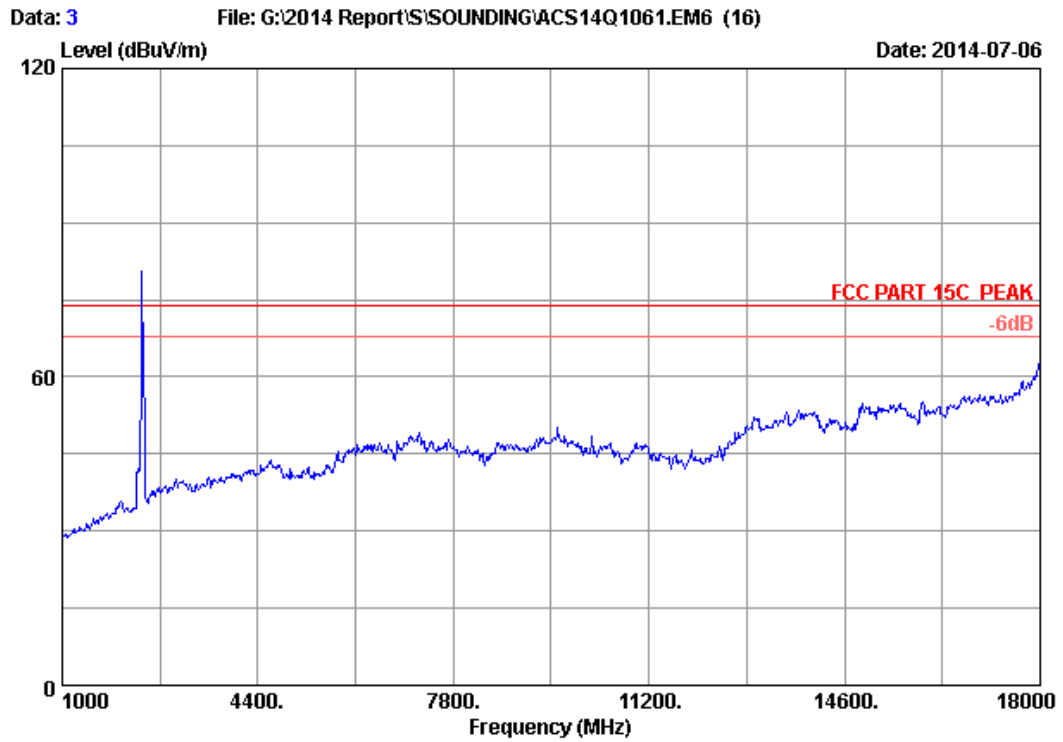

Site no. : 10m Chamber Data no. : 3
Dis. / Ant. : 3m 2013 3115 (4580) Ant. pol. : VERTICAL
Limit : FCC PART 15C PEAK
Env. / Ins. : 24°C/56% Engineer : Eric
EUT : Car Stereo/Video with AM/FM/WXA/DVD/USB/BT
Power rating : DC 3V
Test Mode : GFSK 2402MHz Tx
JWM990

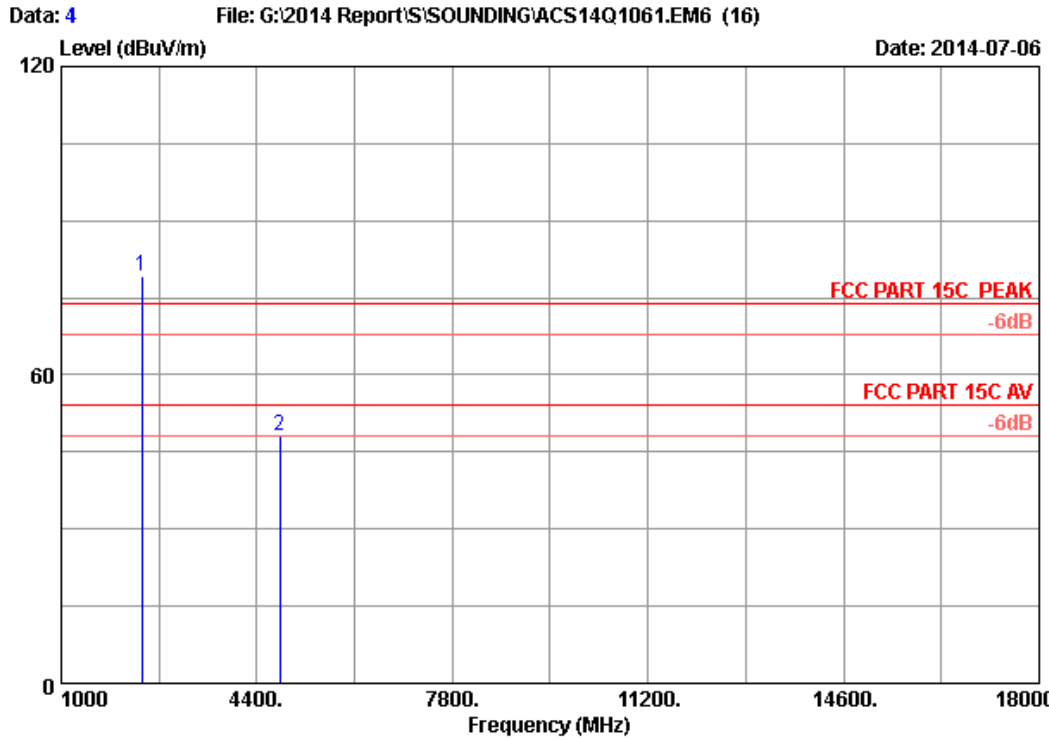

Site no. : 10m Chamber Data no. : 4
 Dis. / Ant. : 3m 2013 3115 (4580) Ant. pol. : VERTICAL
 Limit : FCC PART 15C PEAK
 Env. / Ins. : 24*C/56% Engineer : Eric
 EUT : Car Stereo/Video with AM/FM/WXA/DVD/USB/BT
 Power rating : DC 3V
 Test Mode : GFSK 2402MHz Tx
 JWM990

No.	Freq. (MHz)	Ant. Factor (dB/m)	Cable Loss (dB)	Reading (dBUV)	Emission Level (dBUV/m)	Limits (dBUV/m)	Margin (dB)	Remark
1	2402.000	28.18	6.43	80.16	79.07	74.00	-5.07	Peak
2	4804.000	32.85	8.96	42.11	48.22	74.00	25.78	Peak

Remarks: 1. Emission Level= Antenna Factor + Cable Loss + Reading.
 2. The emission levels that are 20dB below the official limit are not reported.

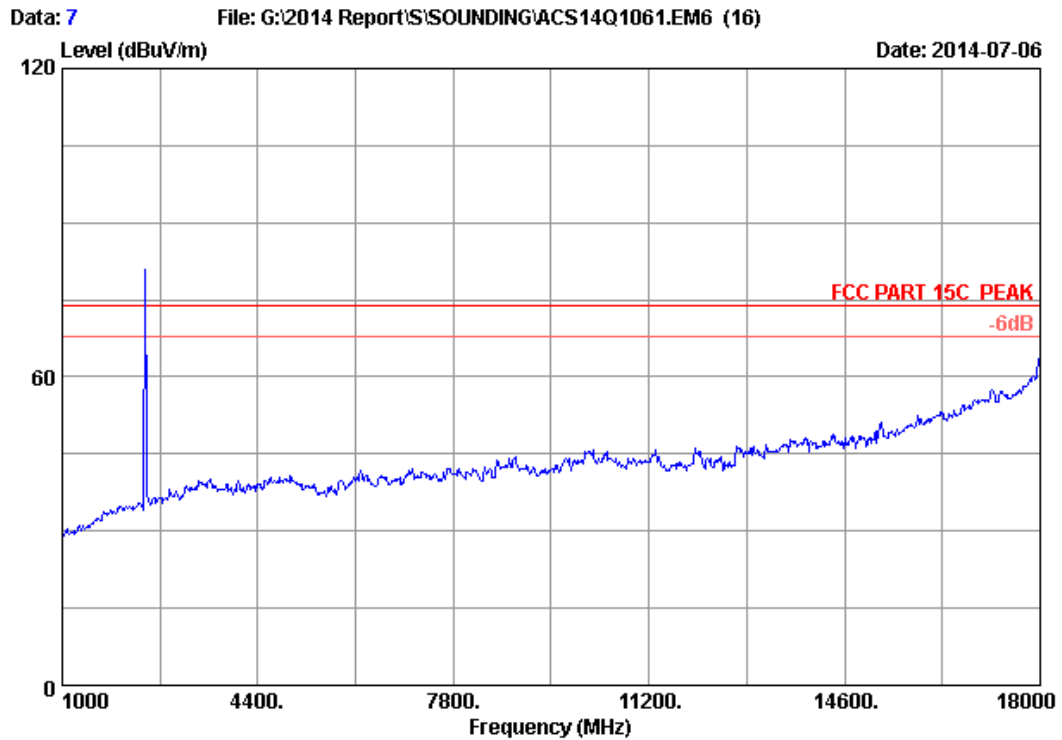

Site no. : 10m Chamber Data no. : 7
Dis. / Ant. : 3m 2013 3115 (4580) Ant. pol. : VERTICAL
Limit : FCC PART 15C PEAK
Env. / Ins. : 24°C/56% Engineer : Eric
EUT : Car Stereo/Video with AM/FM/WXA/DVD/USB/BT
Power rating : DC 3V
Test Mode : GFSK 2441MHz Tx
JWM990

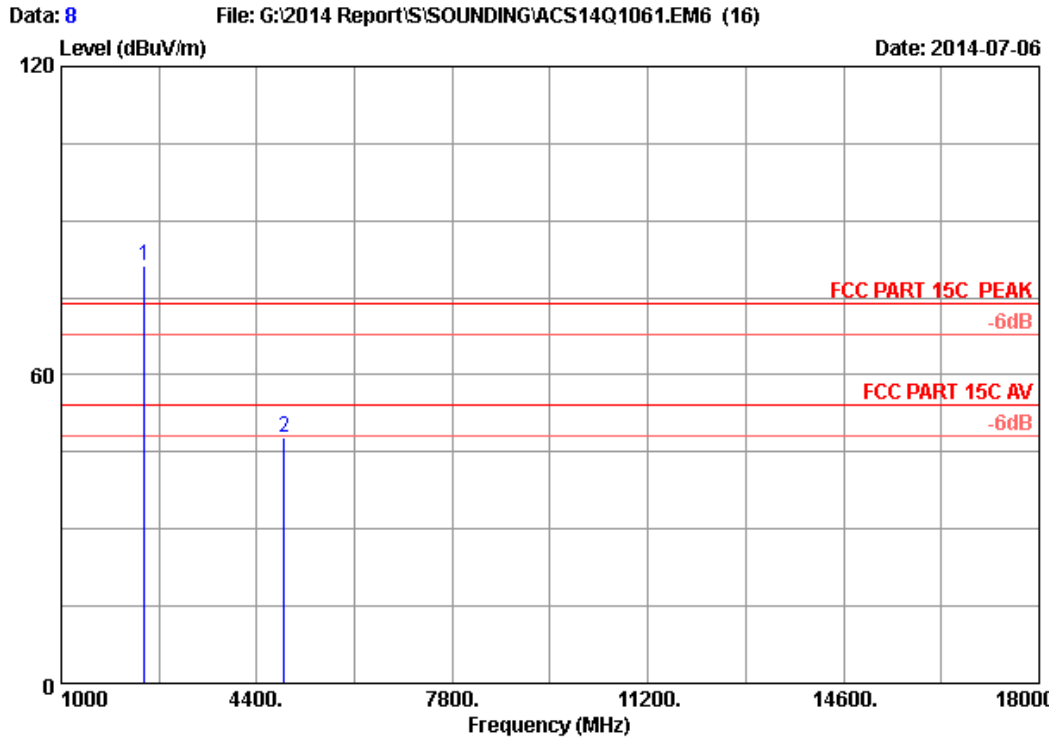

Site no. : 10m Chamber Data no. : 8
 Dis. / Ant. : 3m 2013 3115 (4580) Ant. pol. : VERTICAL
 Limit : FCC PART 15C PEAK
 Env. / Ins. : 24*C/56% Engineer : Eric
 EUT : Car Stereo/Video with AM/FM/WXA/DVD/USB/BT
 Power rating : DC 3V
 Test Mode : GFSK 2441MHz Tx
 JWM990

No.	Freq. (MHz)	Ant. Factor (dB/m)	Cable Loss (dB)	Reading (dBUV)	Emission Level (dBUV/m)	Limits (dBUV/m)	Margin (dB)	Remark
1	2441.000	28.27	6.45	82.16	81.18	74.00	-7.18	Peak
2	4882.000	32.99	8.88	41.76	47.93	74.00	26.07	Peak

Remarks: 1. Emission Level= Antenna Factor + Cable Loss + Reading.
 2. The emission levels that are 20dB below the official limit are not reported.

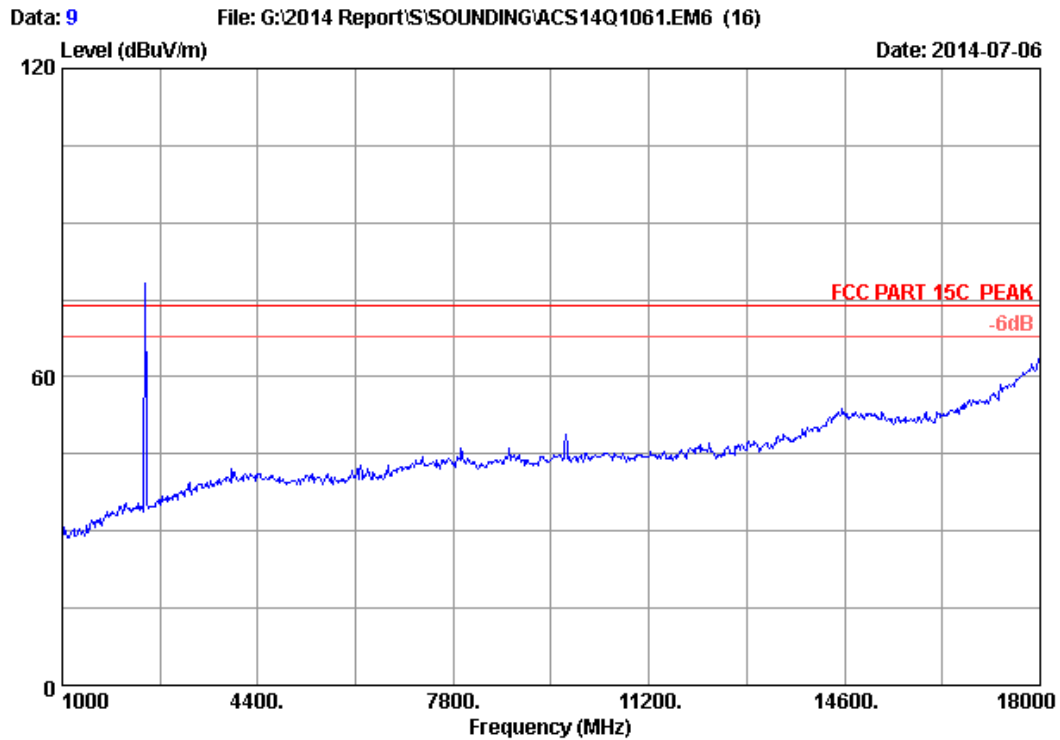

Site no. : 10m Chamber Data no. : 9
Dis. / Ant. : 3m 2013 3115 (4580) Ant. pol. : HORIZONTAL
Limit : FCC PART 15C PEAK
Env. / Ins. : 24°C/56% Engineer : Eric
EUT : Car Stereo/Video with AM/FM/WXA/DVD/USB/BT
Power rating : DC 3V
Test Mode : GFSK 2441MHz Tx
JWM990

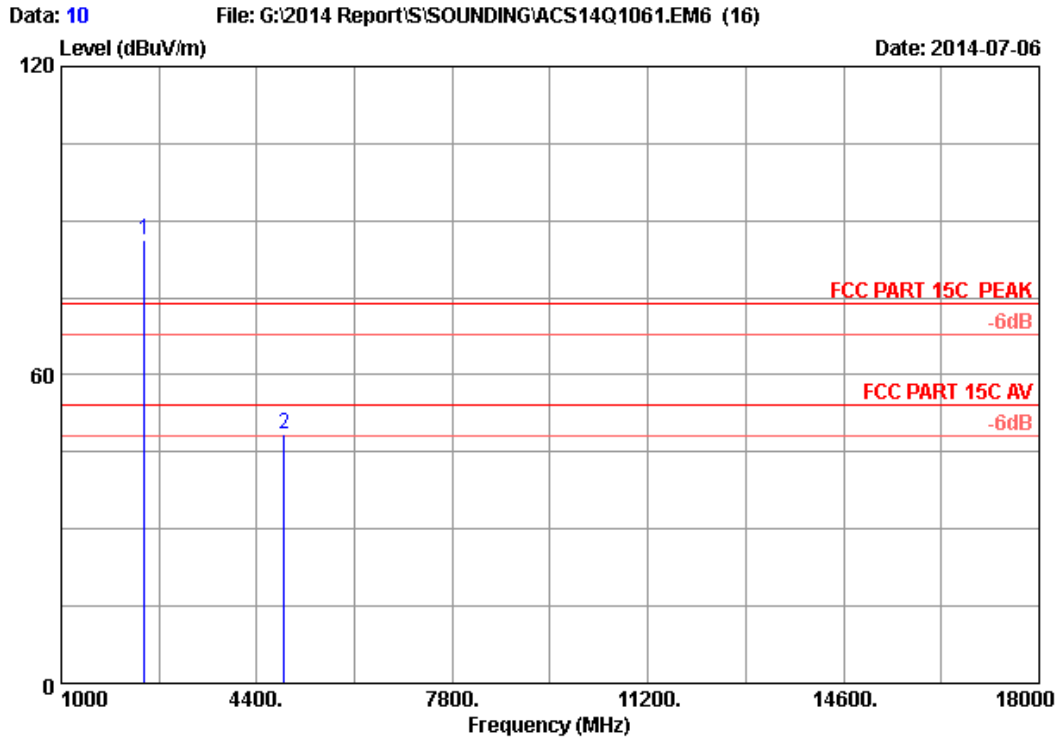

Site no. : 10m Chamber Data no. : 10
 Dis. / Ant. : 3m 2013 3115 (4580) Ant. pol. : HORIZONTAL
 Limit : FCC PART 15C PEAK
 Env. / Ins. : 24*C/56% Engineer : Eric
 EUT : Car Stereo/Video with AM/FM/WXA/DVD/USB/BT
 Power rating : DC 3V
 Test Mode : GFSK 2441MHz Tx
 JWM990

No.	Freq. (MHz)	Ant. Factor (dB/m)	Cable Loss (dB)	Reading (dBUV)	Emission Level (dBUV/m)	Limits (dBUV/m)	Margin (dB)	Remark
1	2441.000	28.27	6.45	87.15	86.17	74.00	-12.17	Peak
2	4882.000	32.99	8.88	42.29	48.46	74.00	25.54	Peak

Remarks: 1. Emission Level= Antenna Factor + Cable Loss + Reading.
 2. The emission levels that are 20dB below the official limit are not reported.

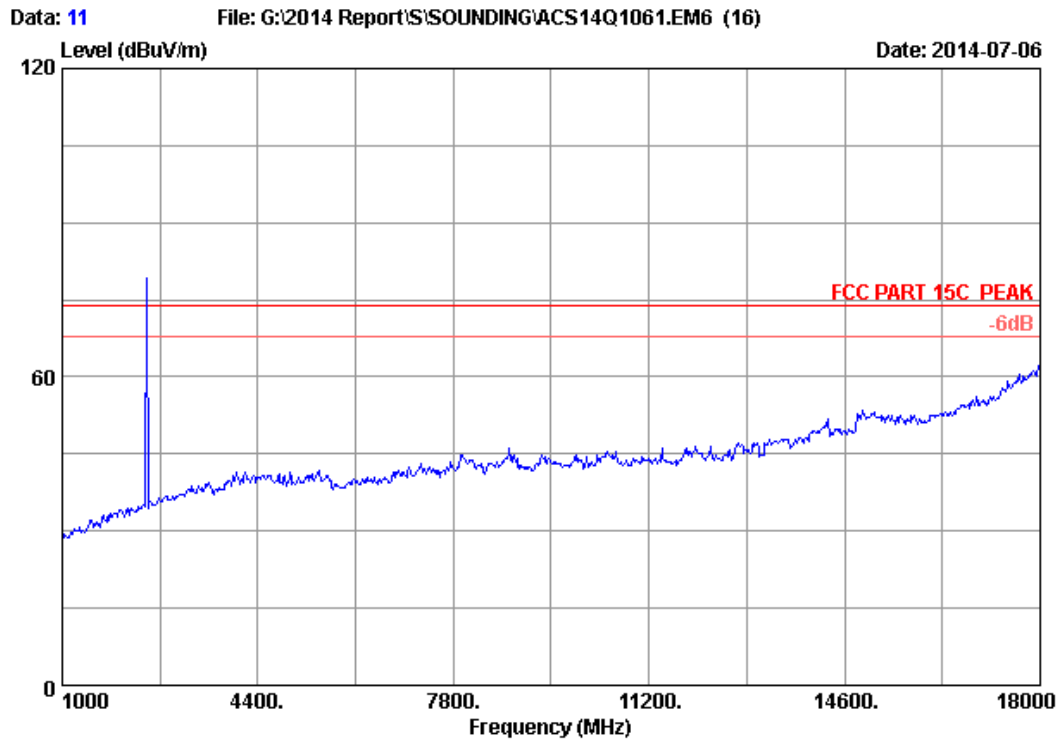

Site no. : 10m Chamber Data no. : 11
Dis. / Ant. : 3m 2013 3115 (4580) Ant. pol. : HORIZONTAL
Limit : FCC PART 15C PEAK
Env. / Ins. : 24°C/56% Engineer : Eric
EUT : Car Stereo/Video with AM/FM/WXA/DVD/USB/BT
Power rating : DC 3V
Test Mode : GFSK 2480MHz Tx
JWM990

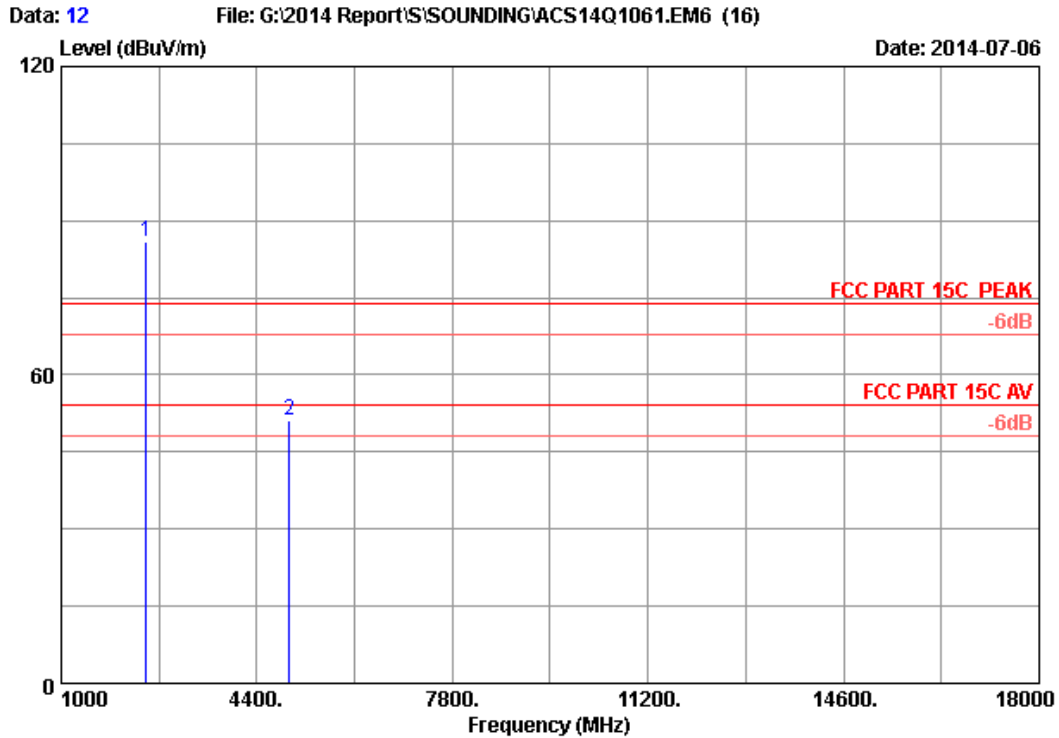

Site no. : 10m Chamber Data no. : 12
 Dis. / Ant. : 3m 2013 3115 (4580) Ant. pol. : HORIZONTAL
 Limit : FCC PART 15C PEAK
 Env. / Ins. : 24*C/56% Engineer : Eric
 EUT : Car Stereo/Video with AM/FM/WXA/DVD/USB/BT
 Power rating : DC 3V
 Test Mode : GFSK 2480MHz Tx
 JWM990

No.	Freq. (MHz)	Ant. Factor (dB/m)	Cable Loss (dB)	Reading (dBUV)	Emission Level (dBUV/m)	Limits (dBUV/m)	Margin (dB)	Remark
1	2480.000	28.36	6.46	86.66	85.78	74.00	-11.78	Peak
2	4960.000	33.13	8.79	45.02	51.24	74.00	22.76	Peak

Remarks: 1. Emission Level= Antenna Factor + Cable Loss + Reading.
 2. The emission levels that are 20dB below the official limit are not reported.

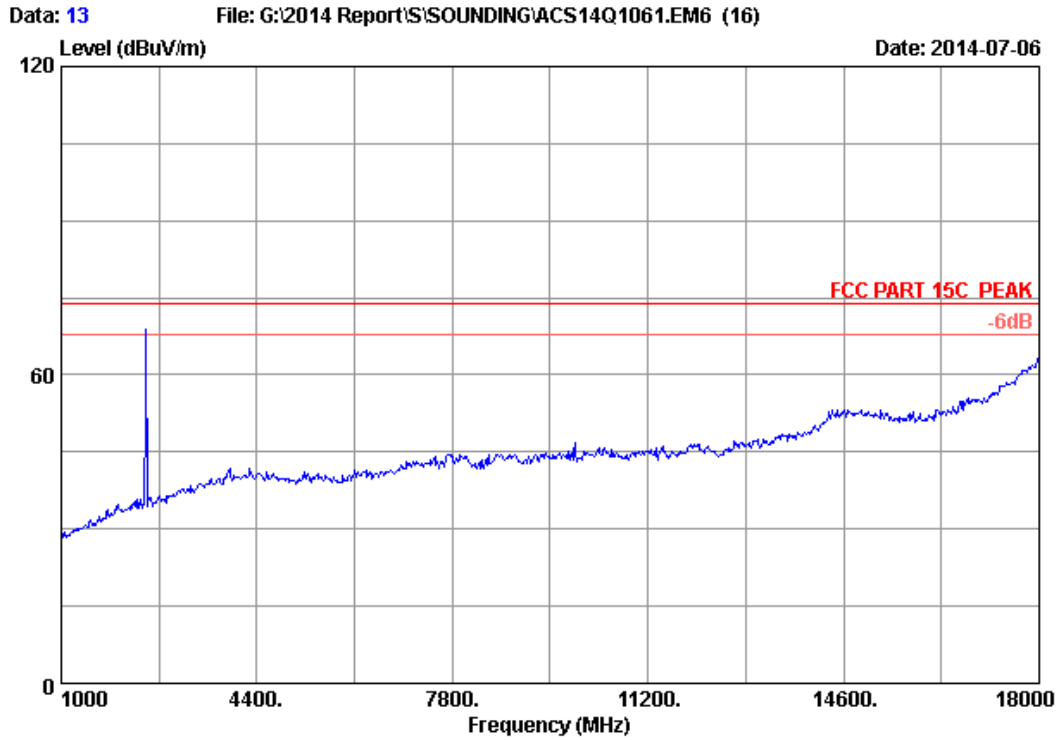

Site no. : 10m Chamber Data no. : 13
Dis. / Ant. : 3m 2013 3115 (4580) Ant. pol. : VERTICAL
Limit : FCC PART 15C PEAK
Env. / Ins. : 24°C/56% Engineer : Eric
EUT : Car Stereo/Video with AM/FM/WXA/DVD/USB/BT
Power rating : DC 3V
Test Mode : GFSK 2480MHz Tx
JWM990

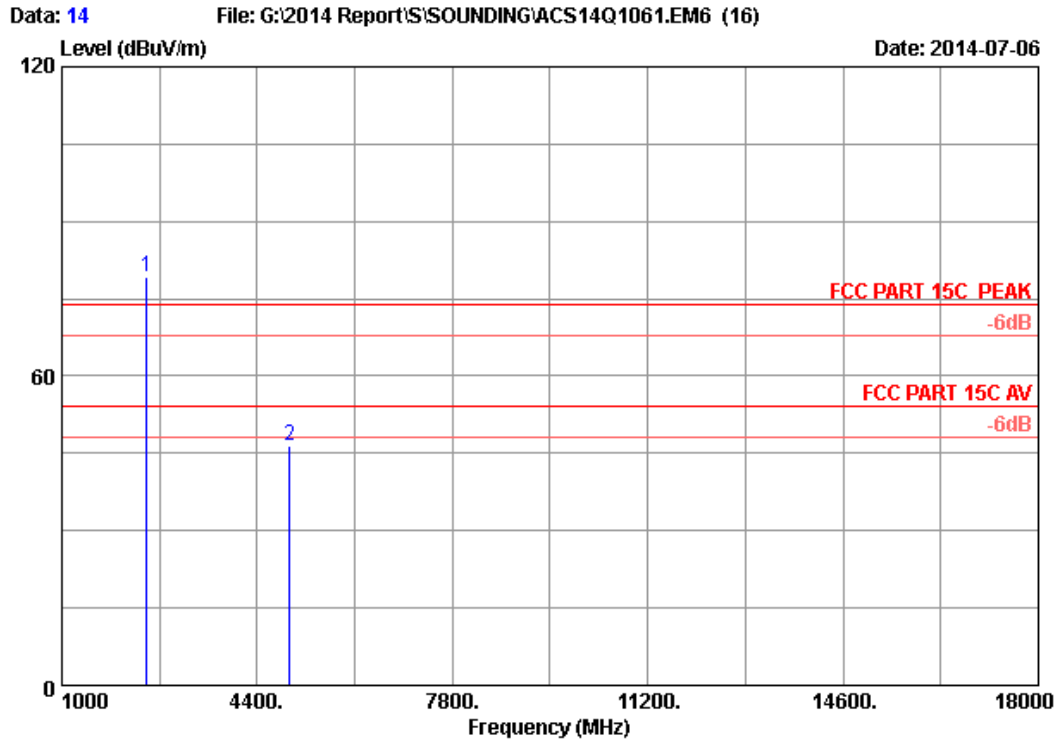

Site no. : 10m Chamber Data no. : 14
 Dis. / Ant. : 3m 2013 3115 (4580) Ant. pol. : VERTICAL
 Limit : FCC PART 15C PEAK
 Env. / Ins. : 24*C/56% Engineer : Eric
 EUT : Car Stereo/Video with AM/FM/WXA/DVD/USB/BT
 Power rating : DC 3V
 Test Mode : GFSK 2480MHz Tx
 JWM990

No.	Freq. (MHz)	Ant. Factor (dB/m)	Cable Loss (dB)	Reading (dBUV)	Emission Level (dBUV/m)	Limits (dBUV/m)	Margin (dB)	Remark
1	2480.000	28.36	6.46	80.15	79.27	74.00	-5.27	Peak
2	4960.000	33.13	8.79	40.11	46.33	74.00	27.67	Peak

Remarks: 1. Emission Level= Antenna Factor + Cable Loss + Reading.
 2. The emission levels that are 20dB below the official limit are not reported.

5. CONDUCTED SPURIOUS EMISSIONS

5.1. Test Equipment

Item	Equipment	Manufacturer	Model No.	Serial No.	Last Cal.	Cal. Interval
1.	Spectrum	Agilent	N9030A	MY51380221	Oct.31, 13	1Year
2.	Attenuator (20dB)	Agilent	8491B	MY39262165	Apr. 28,14	1 Year
3.	RF Cable	Hubersuhner	SUCOFLEX102	28620/2	Apr. 28,14	1 Year

5.2. Limit

In any 100kHz bandwidth outside the frequency bands in which the spread spectrum intentional radiator is operating, the radio frequency power that is produced by the intentional radiator shall be at least 20dB below that in the 100kHz bandwidth within the band that contains the highest level of the desired power.

5.3. Test Procedure

The transmitter output was connected to a spectrum analyzer, The resolution bandwidth is set to 100 kHz, The video bandwidth is set to 300 kHz and measure all the emissions detected.

5.4. Test result

PASS (The testing data was attached in the next pages.)

**Hopping Off
GFSK
2402MHz**

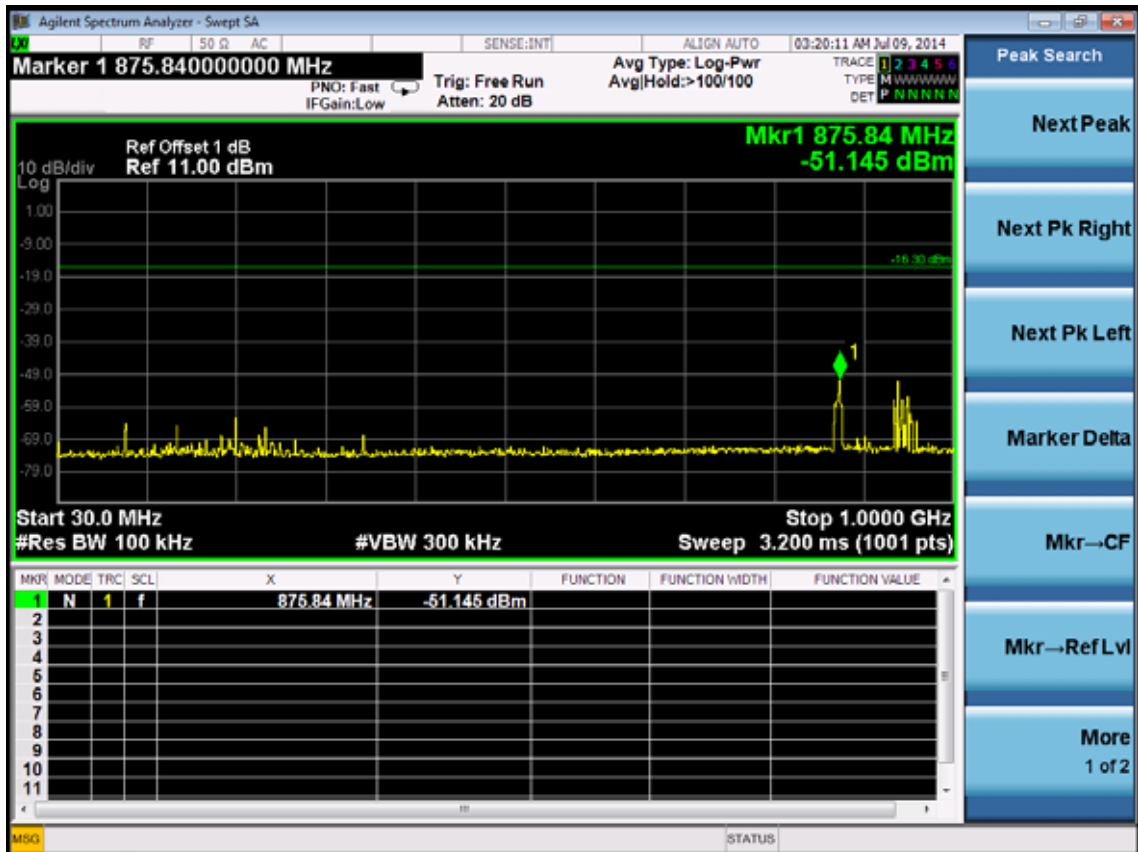
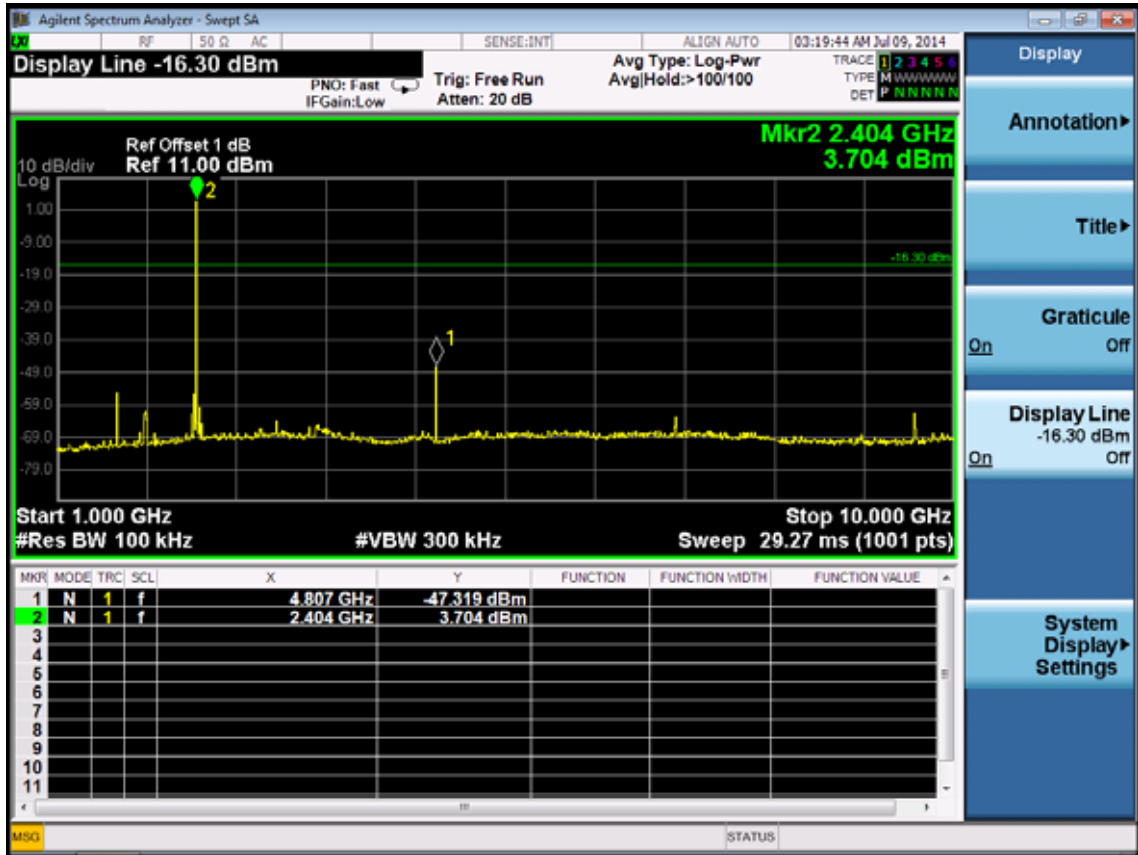

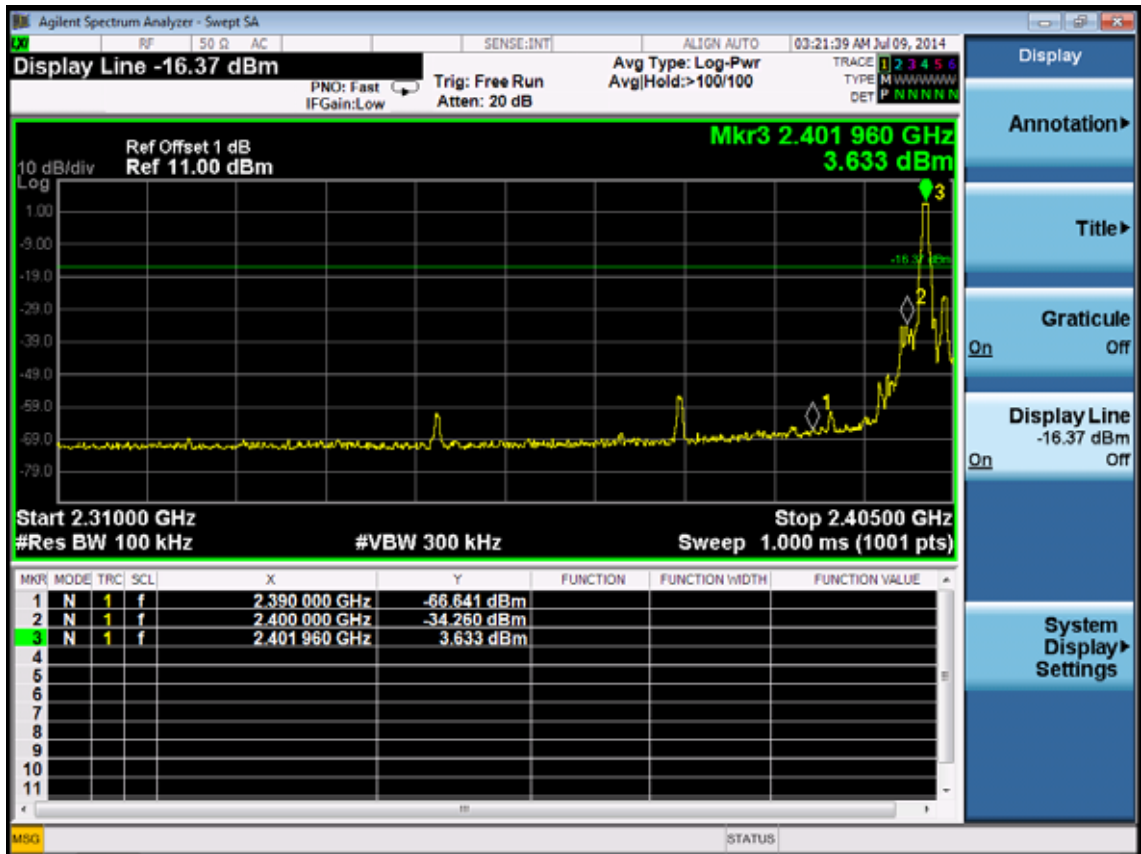
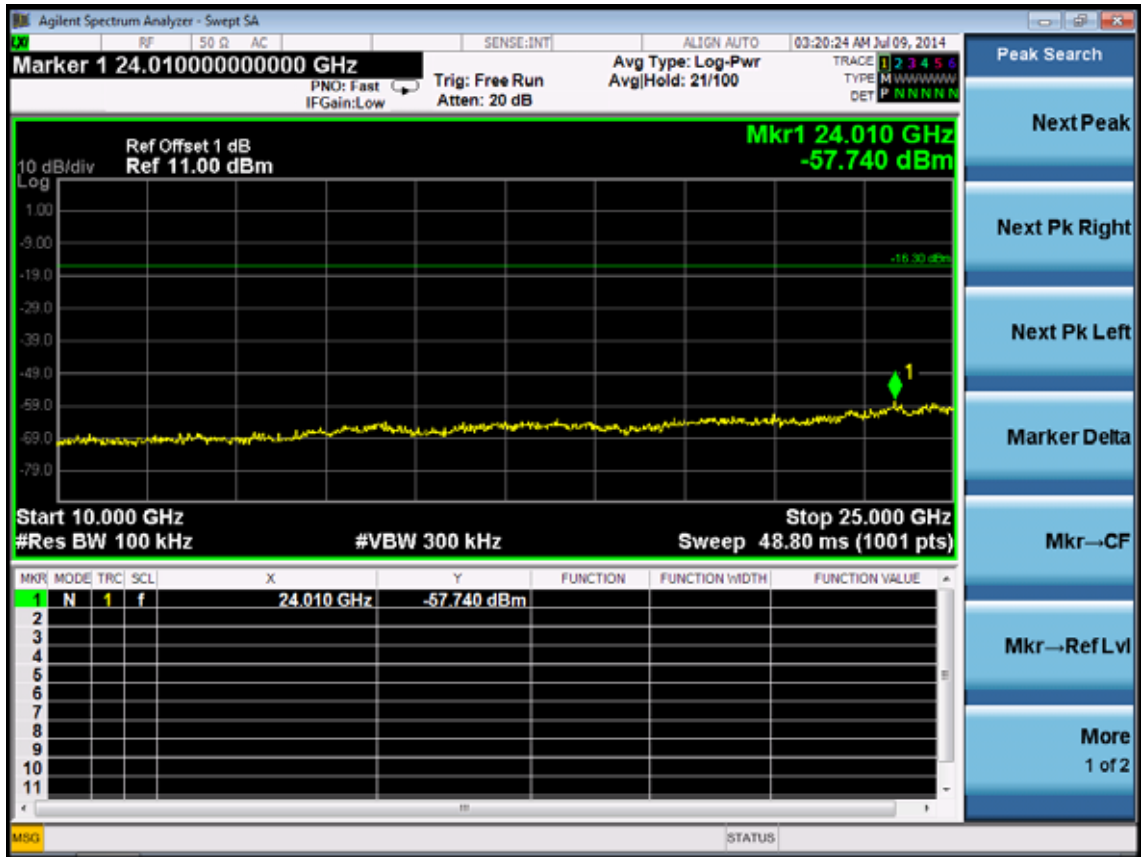

2441MHz

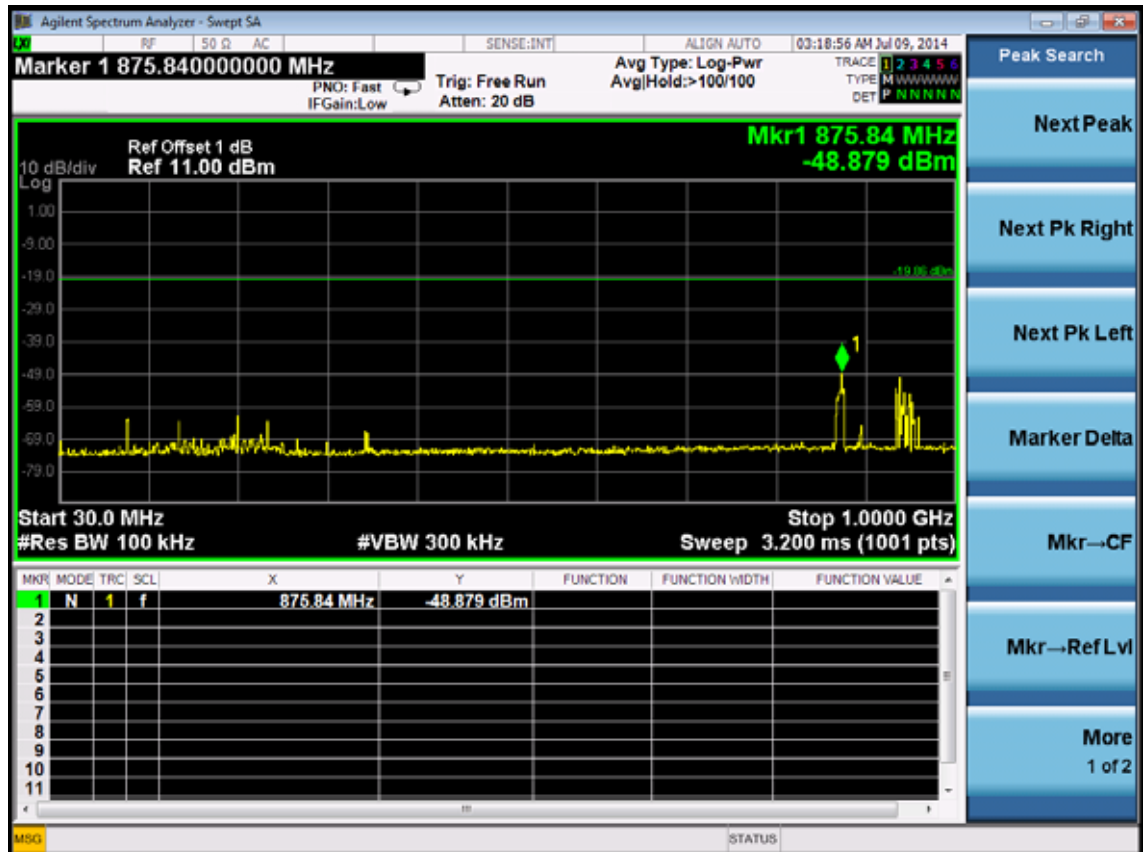
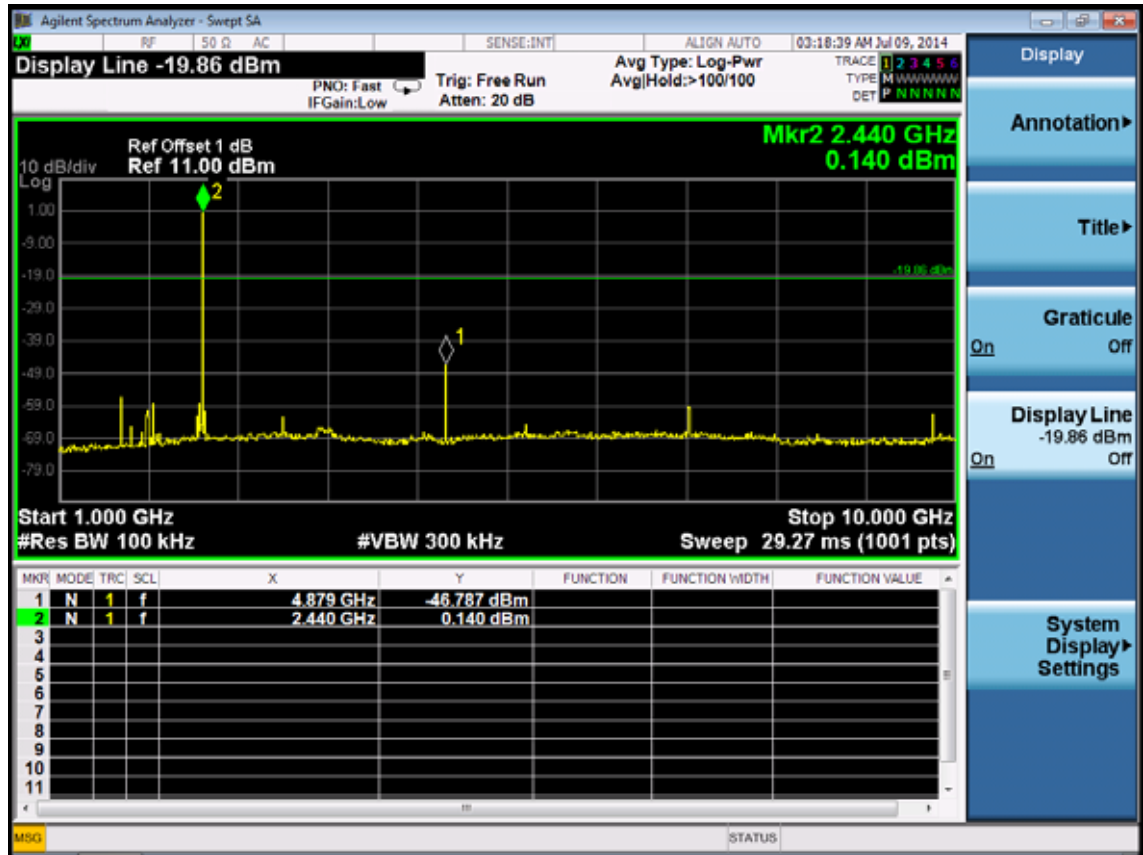

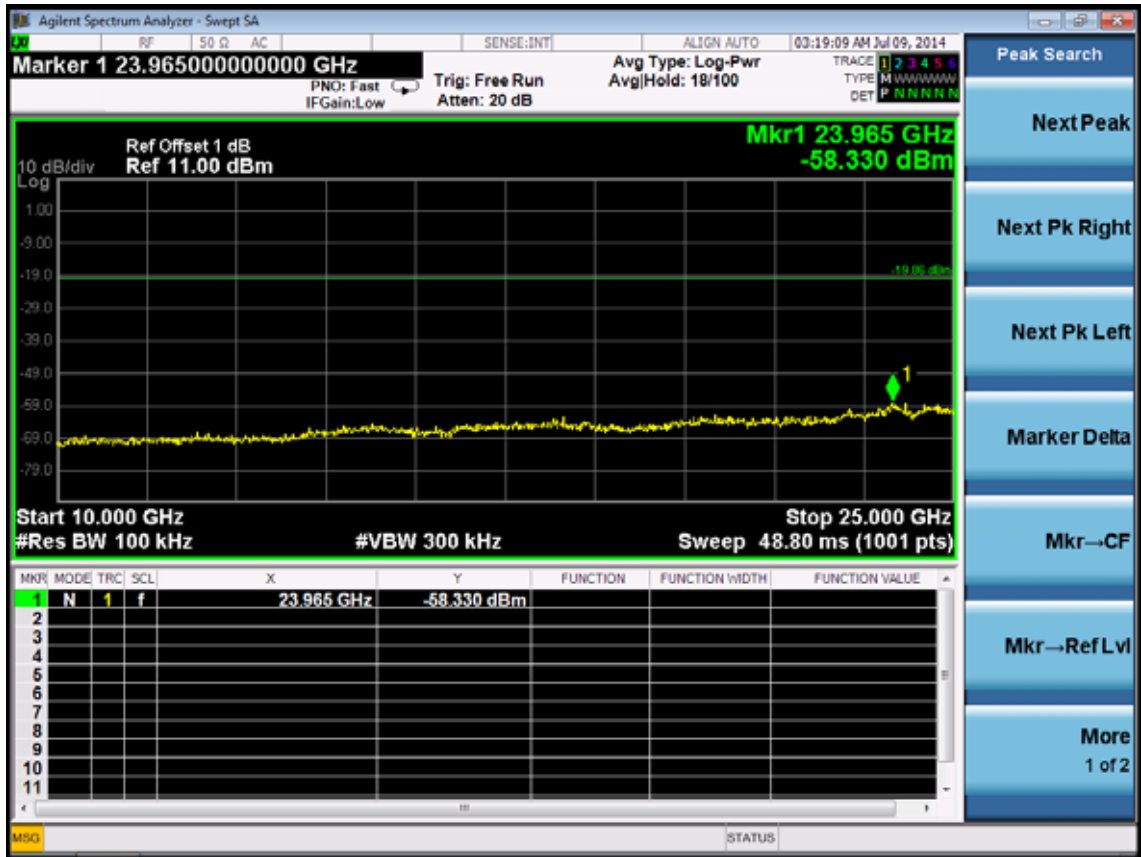

2480MHz

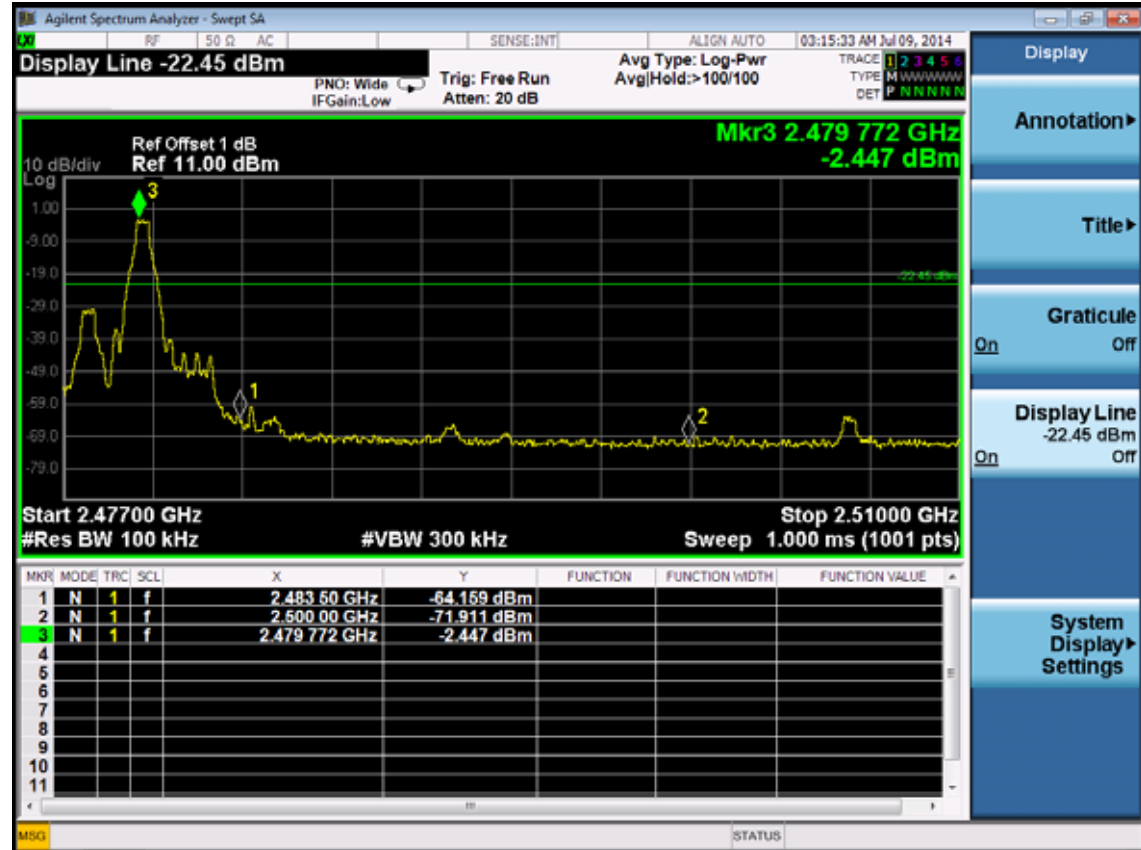

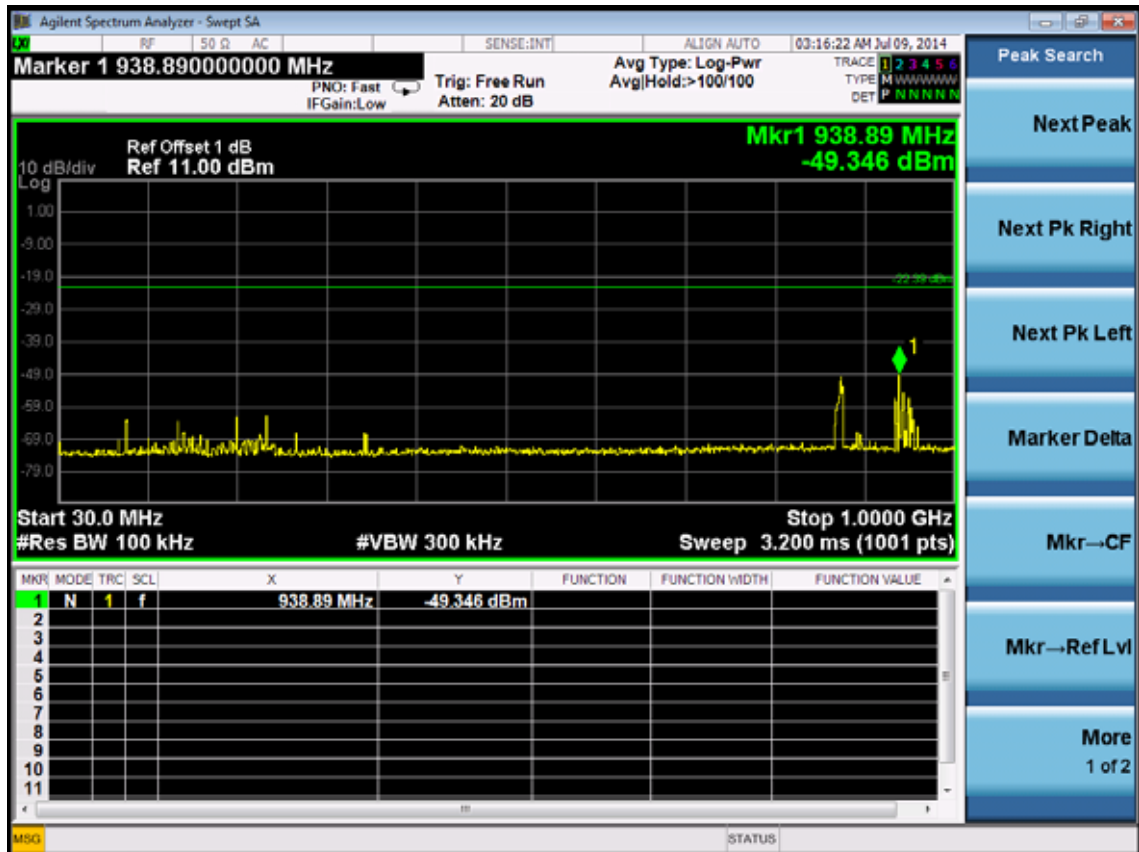
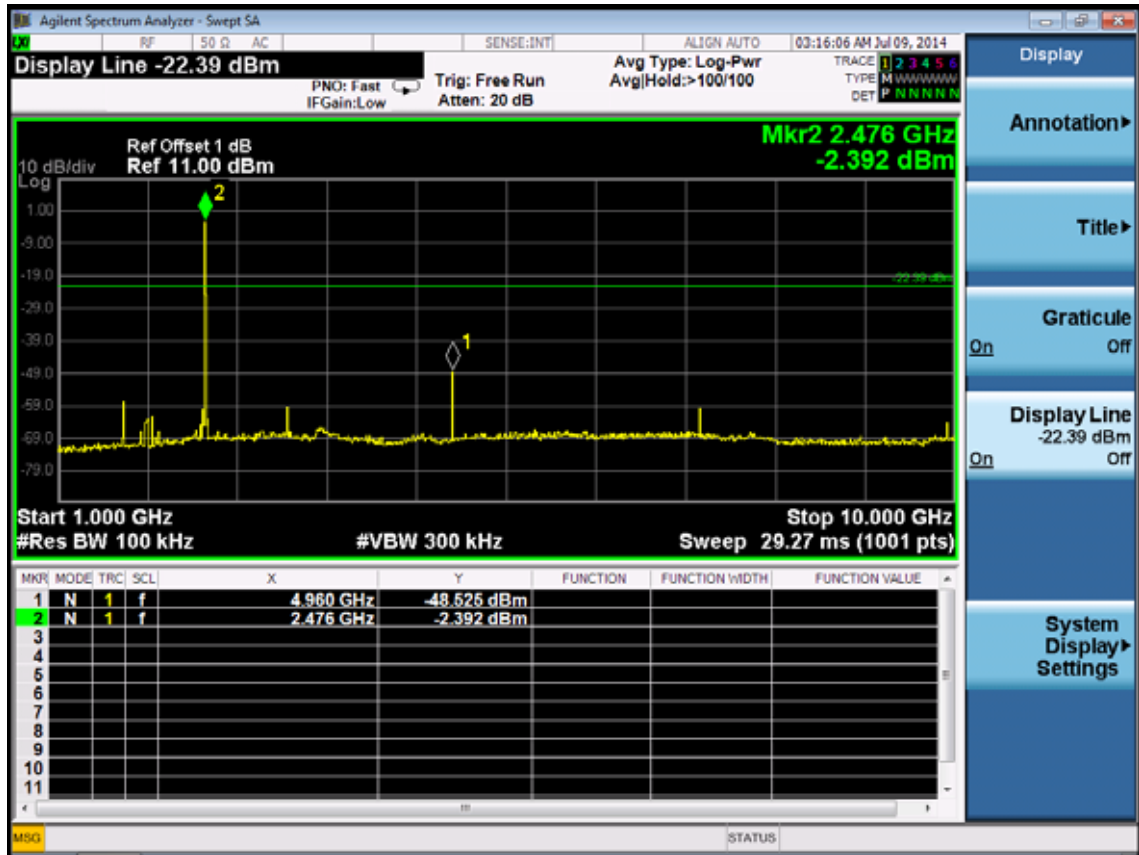

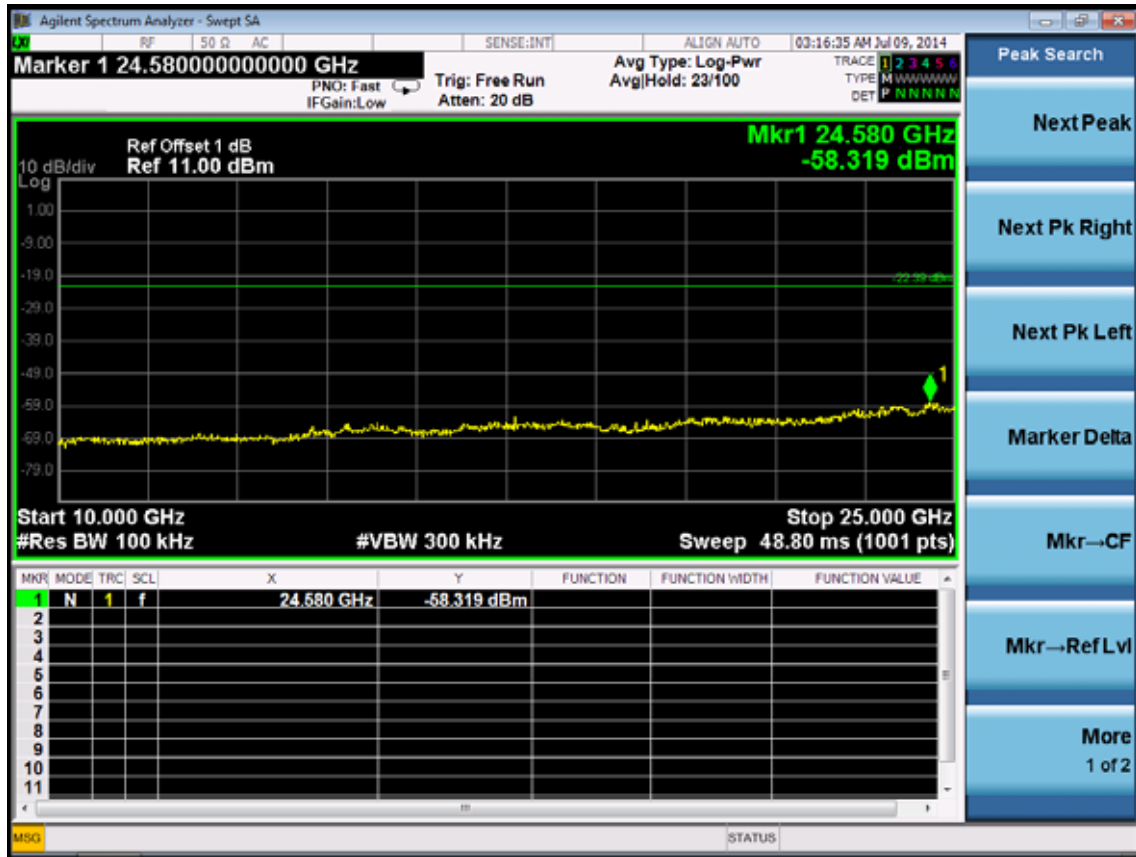

Hopping on

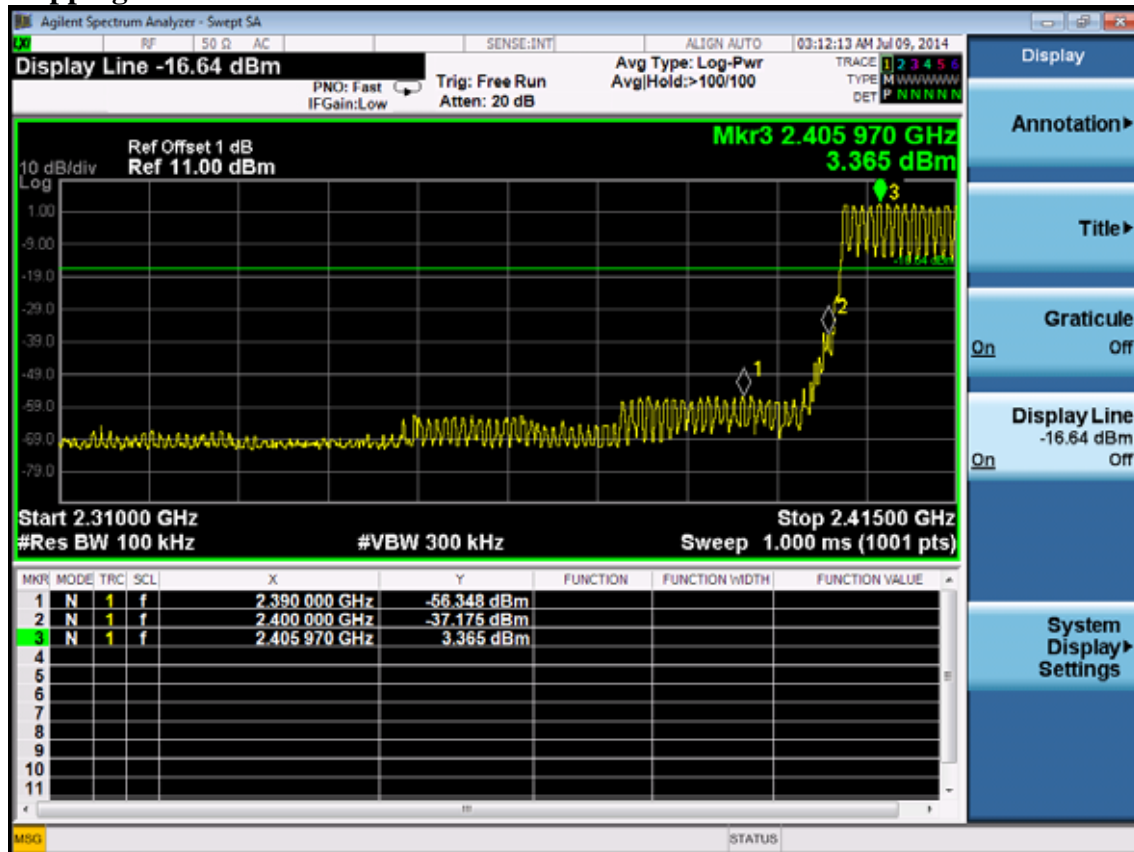

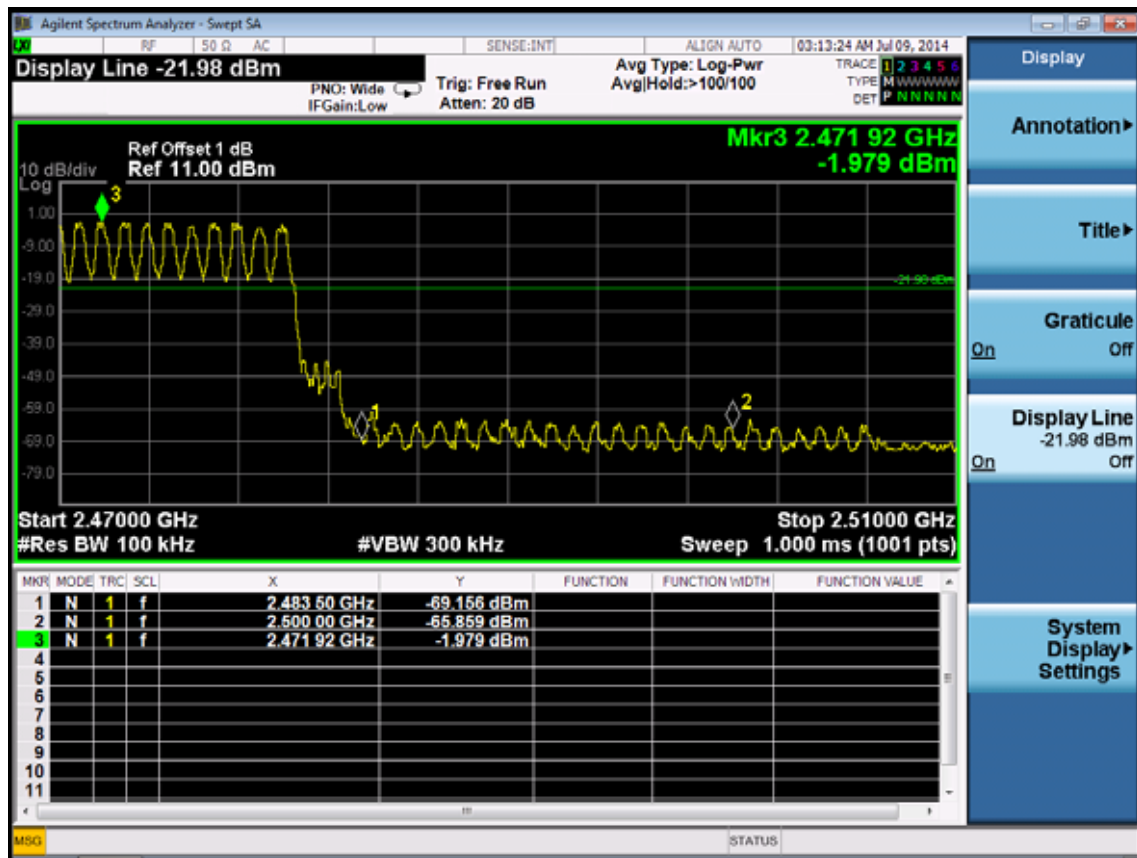

6. CARRIER FREQUENCY SEPARATION TEST

6.1. Test Equipment

Item	Equipment	Manufacturer	Model No.	Serial No.	Last Cal.	Cal. Interval
1	Spectrum Analyzer	Agilent	N9030A	MY51380221	Oct.31, 13	1Year

6.2. Limit

Frequency hopping systems shall have hopping channel carrier frequency separated by a minimum of 25kHz or the 20dB bandwidth of the hopping channel, whichever is greater. Alternatively, frequency hopping systems operating in the 2400-2483.5 MHz band may have hopping channel carrier frequencies that are separated by 25 kHz or two-thirds of the 20 dB bandwidth of the hopping channel, whichever is greater, provided the systems operate with an output power no greater than 125 mW.

6.3. Test Results.

EUT: Car Stereo/Video with AM/FM/WXA/DVD/USB/BT		
M/N: JWM990		
Test date: 2014-07-09	Pressure: 101.3±1.0 kpa	Humidity: 52.1±3.0%
Tested by: Eric	Test site: RF Site	Temperature: 22.8±0.6°C

Test Mode	Channel separation	Conclusion
GFSK	1.0MHz	PASS



7. 20 DB BANDWIDTH TEST

7.1. Test Equipment

Item	Equipment	Manufacturer	Model No.	Serial No.	Last Cal.	Cal. Interval
1.	Spectrum Analyzer	Agilent	N9030A	MY51380221	Oct.31, 13	1Year

7.2. Limit

Intentional radiators operating under the alternative provisions to the general emission limits, as contained in §§ 15.217 through 15.257 and in Subpart E of this part, must be designed to ensure that the 20 dB bandwidth of the emission, or whatever bandwidth may otherwise be specified in the specific rule section under which the equipment operates, is contained within the frequency band designated in the rule section under which the equipment is operated.

7.3. Test Results

EUT: Car Stereo/Video with AM/FM/WXA/DVD/USB/BT		
M/N: JWM990		
Test date: 2014-07-09	Pressure: 101.3±1.0 kpa	Humidity: 52.1±3.0%
Tested by: Eric	Test site: RF Site	Temperature: 22.8±0.6°C

Cable loss: 1 dB			
Test Mode	Frequency (MHz)	20dB bandwidth (KHz)	Limit (KHz)
GFSK	2402	846.9	N/A
	2441	833.5	N/A
	2480	815.3	N/A
Conclusion : PASS			

GFSK

Test Frequency: 2402MHz

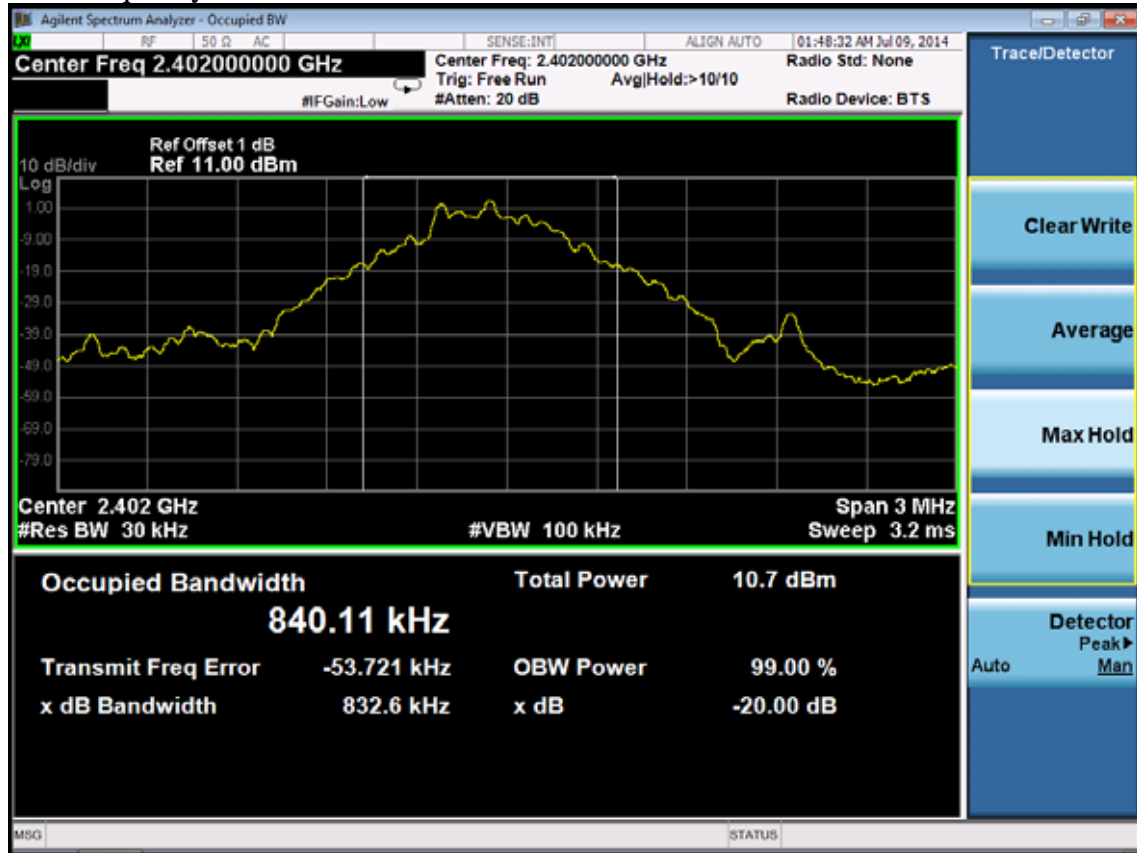

Test Frequency: 2441MHz

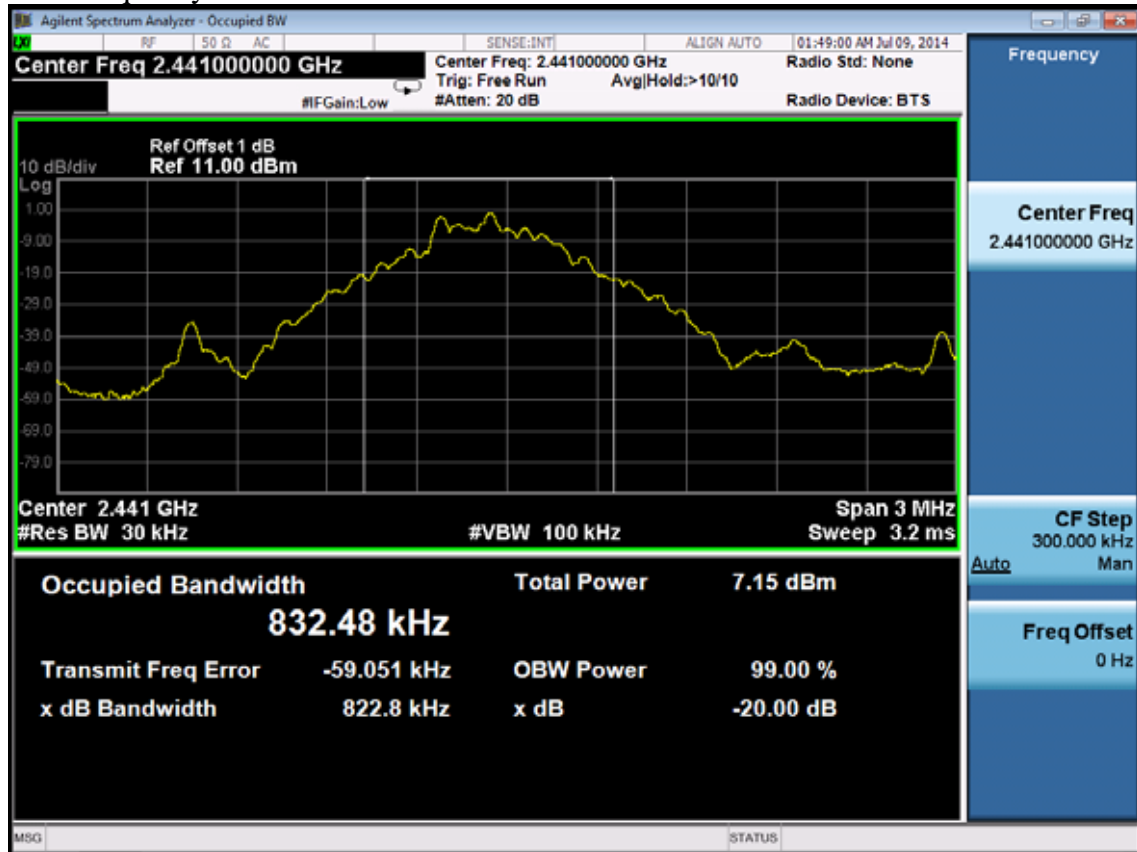

Test Frequency: 2480MHz



8. NUMBER OF HOPPING FREQUENCY TEST

8.1. Test Equipment

Item	Equipment	Manufacturer	Model No.	Serial No.	Last Cal.	Cal. Interval
1	Spectrum Analyzer	Agilent	N9030A	MY51380221	Oct.31, 13	1Year

8.2. Limit

Frequency hopping systems in the 2400-2483.5 MHz band shall use at least 15 channels

8.3. Test Results

EUT: Car Stereo/Video with AM/FM/WXA/DVD/USB/BT		
M/N: JWM990		
Test date: 2014-07-09	Pressure: 101.3±1.0 kpa	Humidity: 52.1±3.0%
Tested by: Eric	Test site: RF Site	Temperature : 22.8±0.6°C

Test Mode	Number of channel	Limit	Conclusion
GFSK	79	>=15	PASS

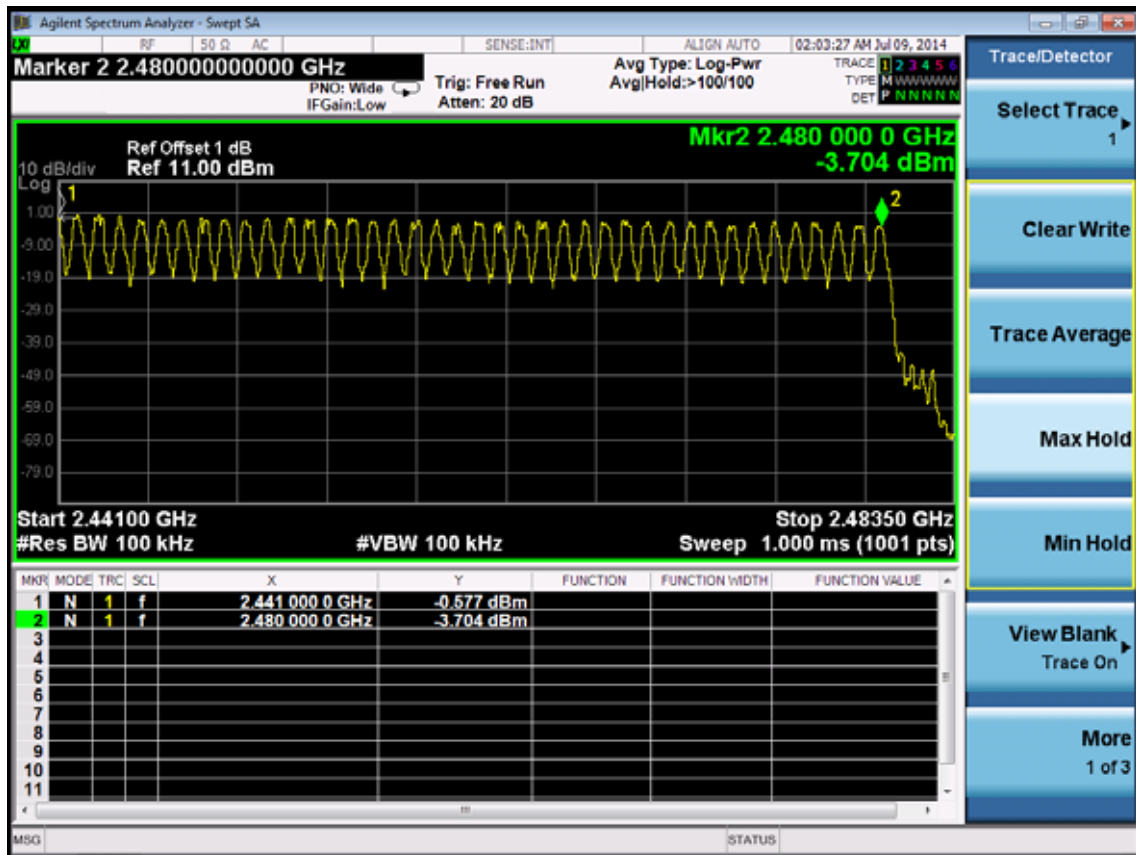
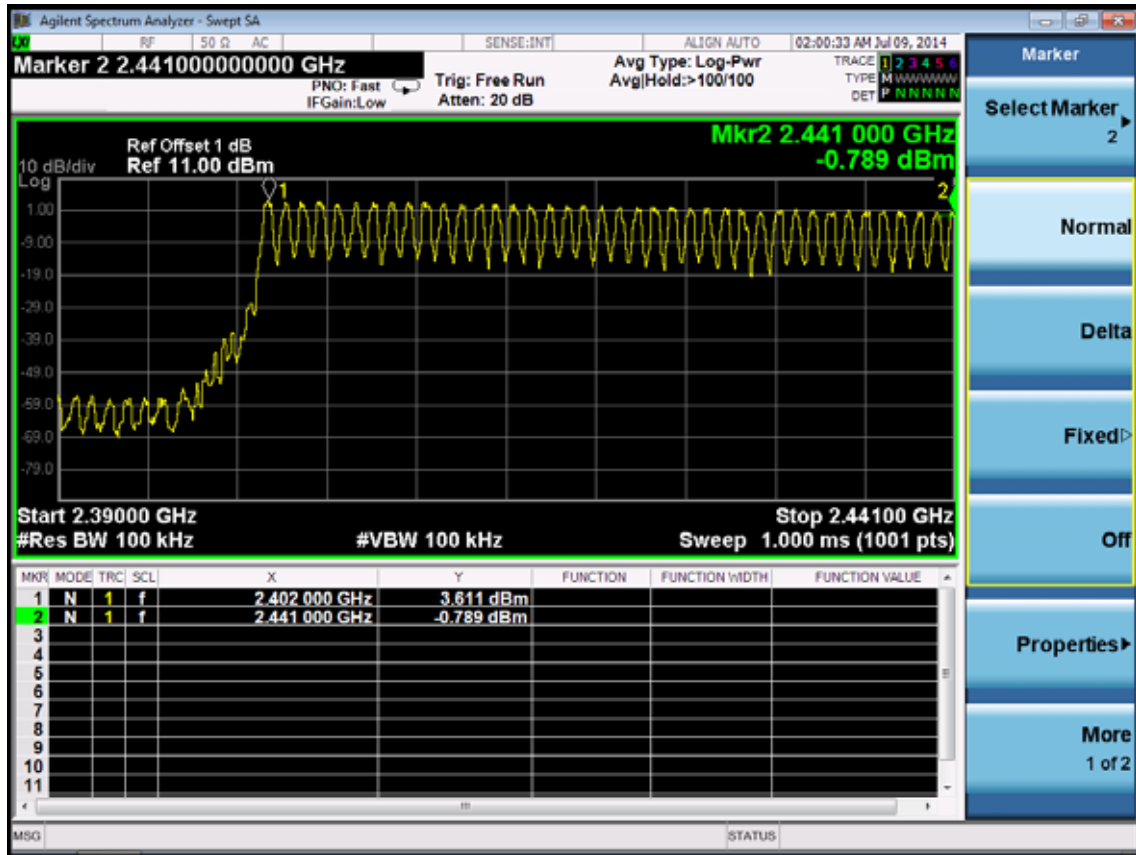

9. DWELL TIME

9.1. Test Equipment

Item	Equipment	Manufacturer	Model No.	Serial No.	Last Cal.	Cal. Interval
1	Spectrum Analyzer	Agilent	N9030A	MY51380221	Oct.31, 13	1Year

9.2. Limit

The average time of occupancy on any channel shall not be greater than 0.4 seconds within a period of 0.4 seconds multiplied by the number of hopping channels employed.

9.3. Test Results

EUT: Car Stereo/Video with AM/FM/WXA/DVD/USB/BT		
M/N: JWM990		
Test date: 2014-09-06	Pressure: 101.3±1.0 kpa	Humidity: 52.1±3.0%
Tested by: Eric	Test site: RF Site	Temperature : 22.8±0.6°C

Mode	dwll time	Limit	Conclusion	
GFSK	DH1	$53\text{hops}/5\text{s} * 0.4 * 79\text{chanel} * 0.442\text{ms} = 148.053\text{ms}$	<400ms	PASS
	DH3	$25\text{hops}/5\text{s} * 0.4 * 79\text{chanel} * 1.713\text{ms} = 270.65\text{ms}$	<400ms	PASS
	DH5	$16\text{hops}/5\text{s} * 0.4 * 79\text{chanel} * 2.970\text{ms} = 300.33\text{ms}$	<400ms	PASS

Note: All the lower levels were signal from receiver's, and should not considered in here.

GFSK
DH 1

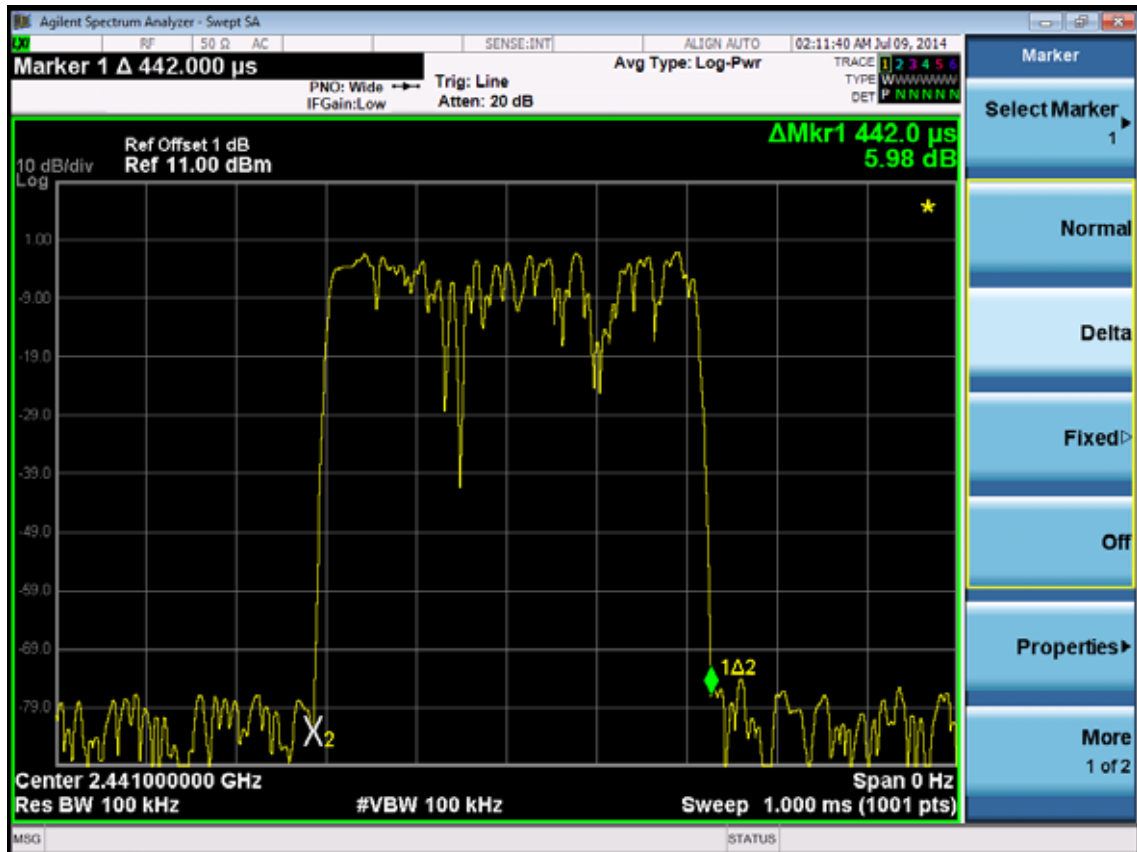
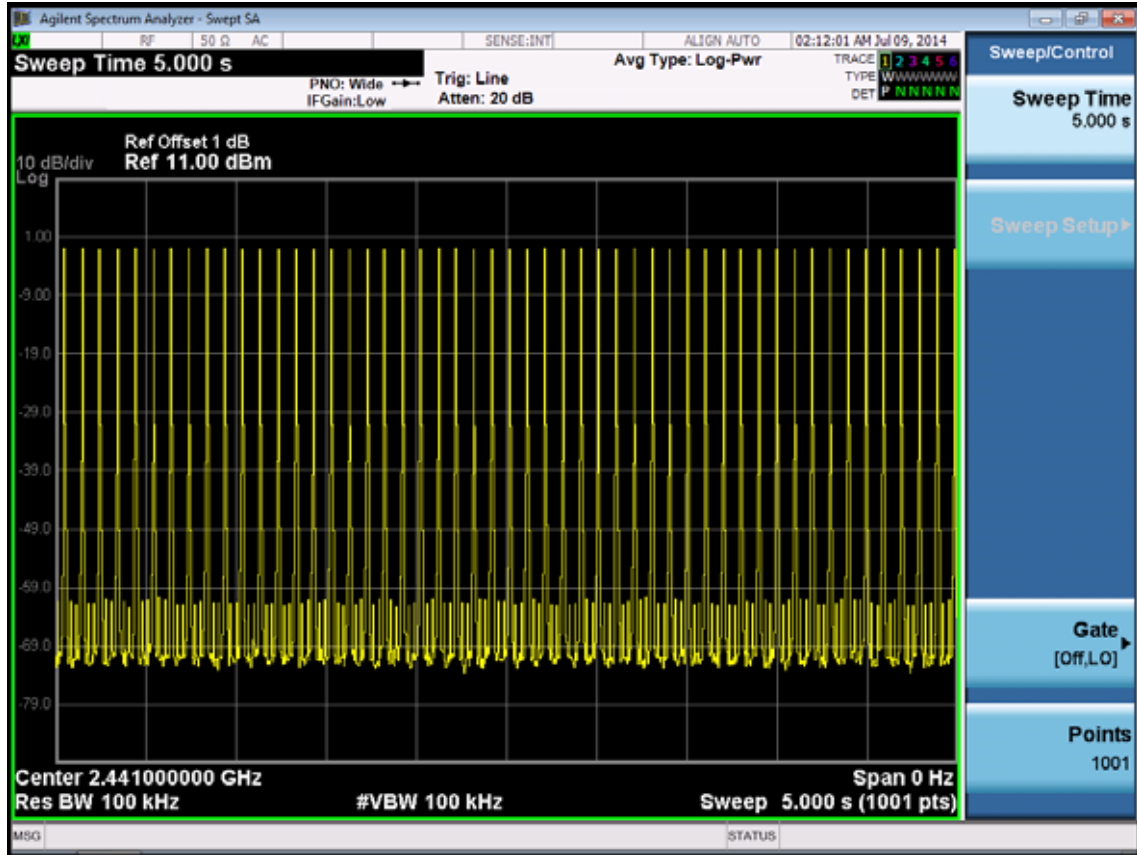

DH 3

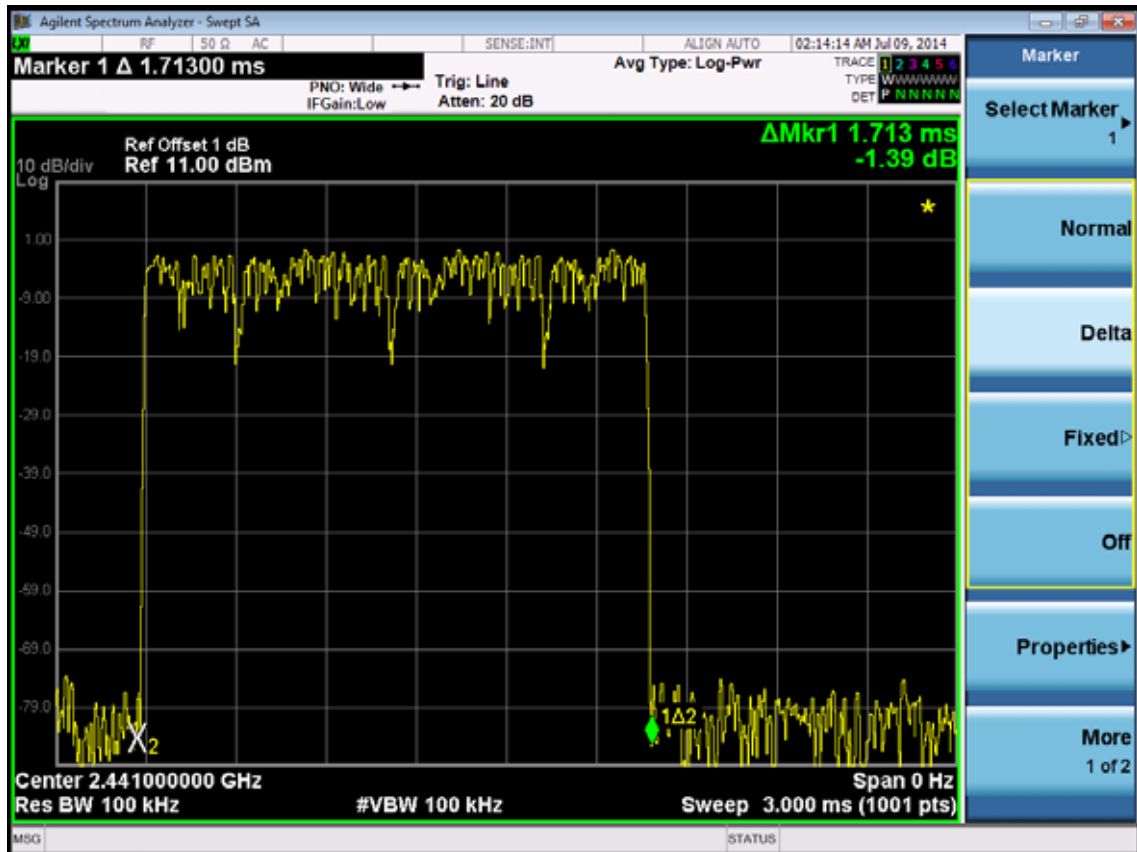
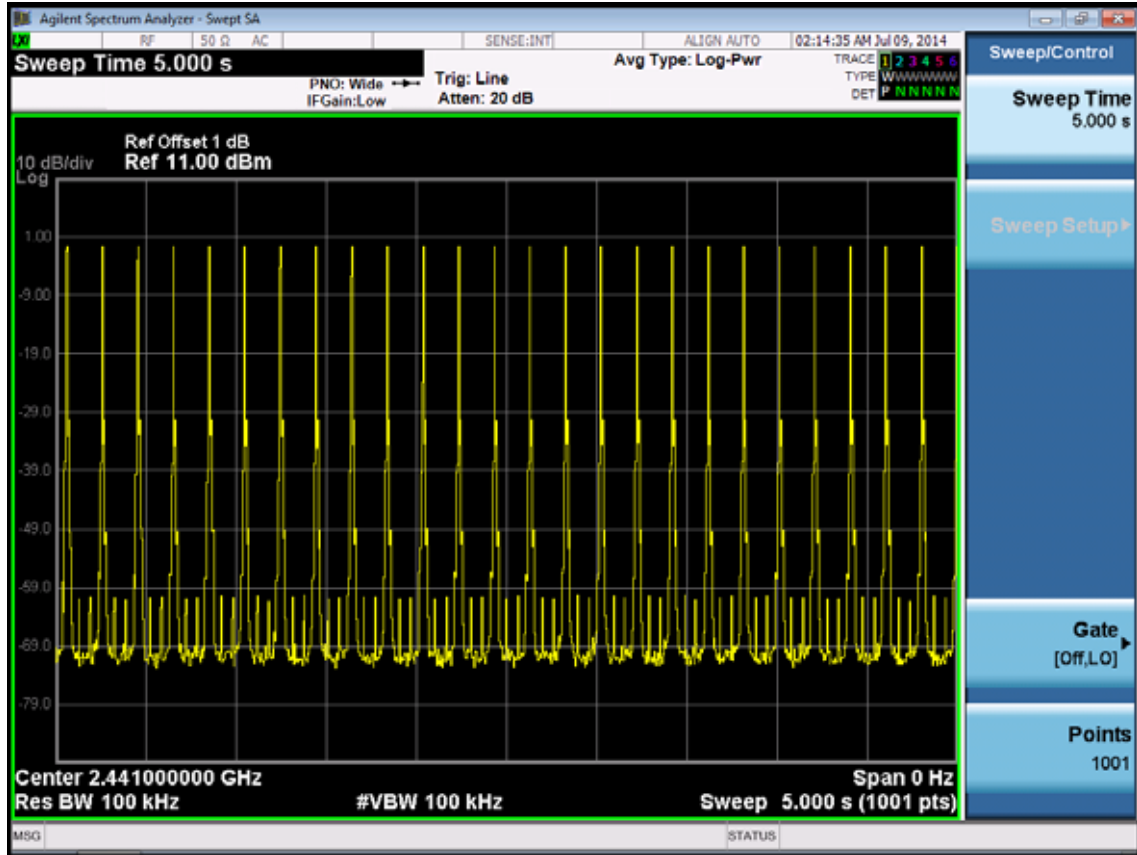

DH 5

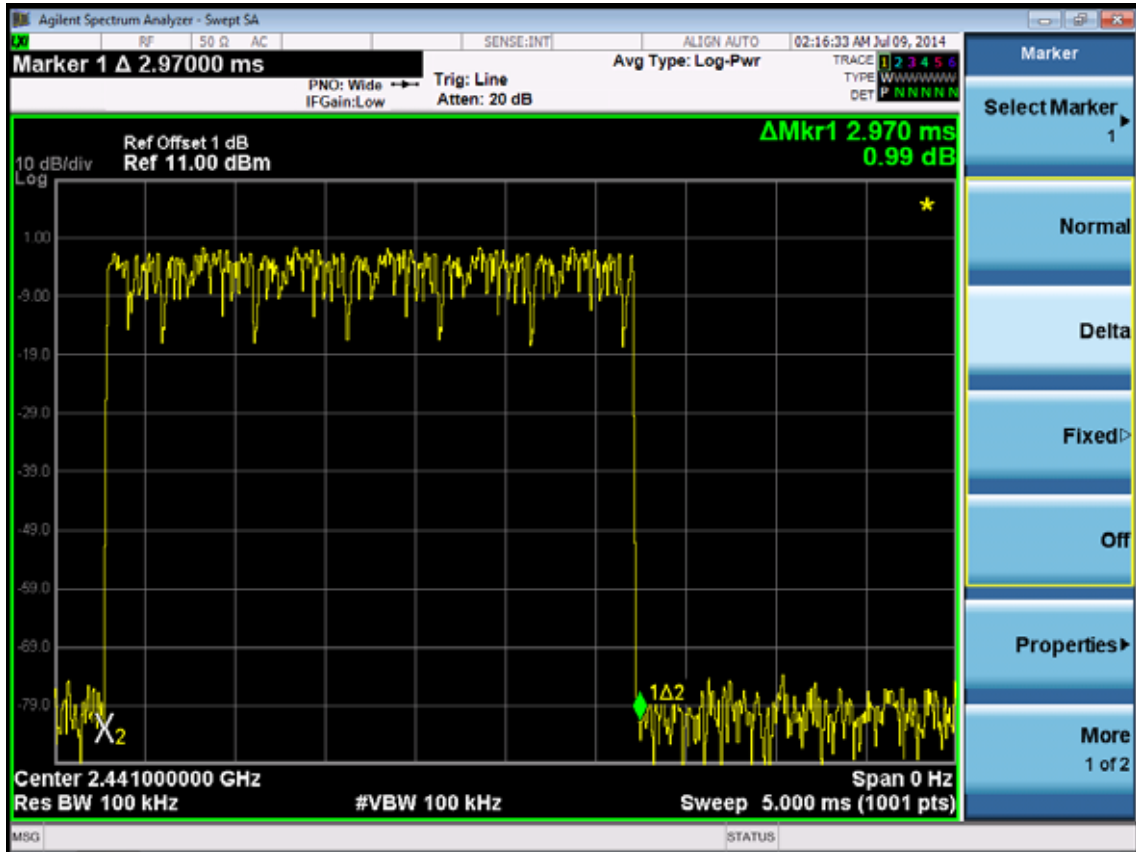
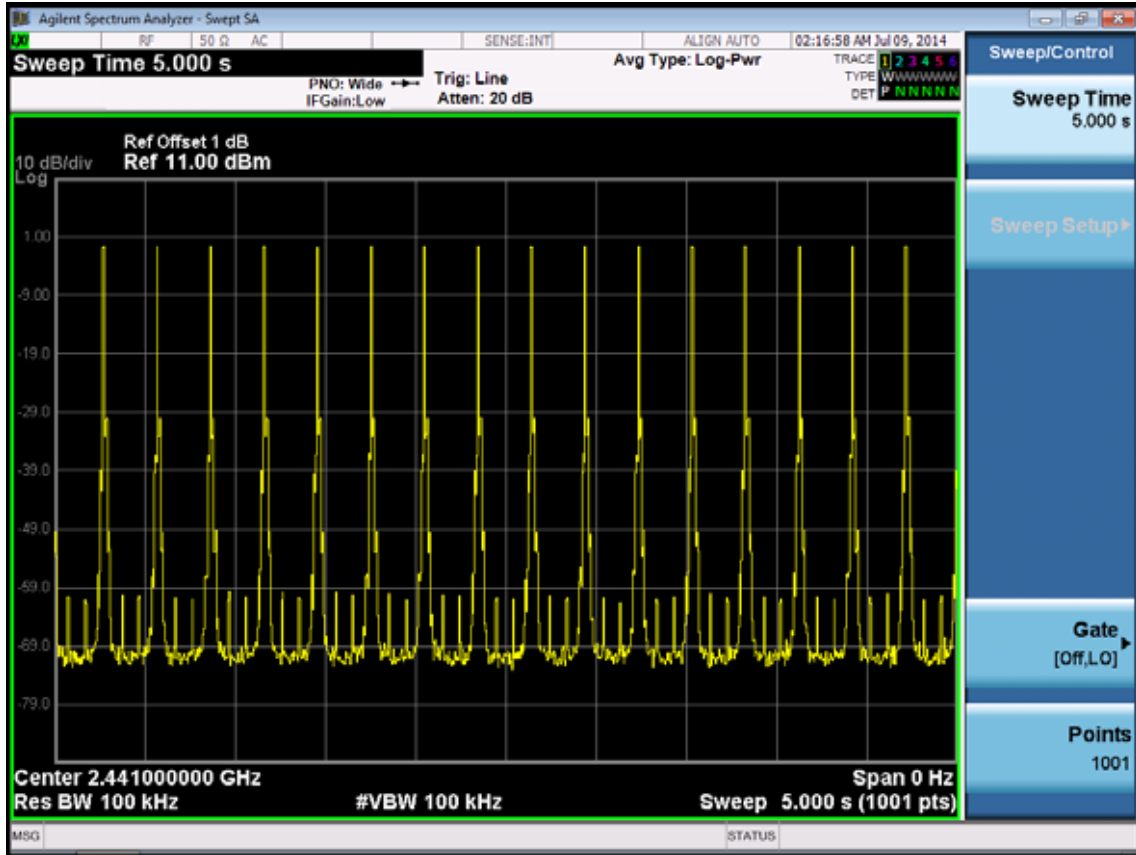

10. MAXIMUM PEAK OUTPUT POWER TEST

10.1. Test Equipment

Item	Equipment	Manufacturer	Model No.	Serial No.	Last Cal.	Cal. Interval
2.	Spectrum	Agilent	N9030A	MY51380221	Oct.31, 13	1 Year
3.	Power meter	Anritsu	ML2487A	6K00002472	Apr. 28,14	1 Year
4.	Power sensor	Anritsu	MA2491A	0033005	Apr. 28,14	1 Year
5.	Attenuator (20dB)	Agilent	8491B	MY39262165	Apr. 28,14	1 Year
6	RF Cable	Hubersuhner	SUCOFLEX102	28610/2	Apr. 28,14	1 Year

10.2. Limit

For frequency hopping systems operating in the 2400-2483.5 MHz band employing at least 75 non-overlapping hopping channels, and all frequency hopping systems in the 5725-5850 MHz band: 1 watt. For all other frequency hopping systems in the 2400-2483.5 MHz band: 0.125 watts.

10.3. Test Procedure

1. Connected the EUT's antenna port to spectrum analyzer.
2. Set the RBW> Bandwidth of test Frequency and put the test Frequency, Set the Span large enough to capture the entire signal
3. Use a peak detector on max hold
4. Reading the value from the Spectrum analyzer

Note: The cable loss and attenuator loss were offset into measure device as an amplitude offset.

10.4. Test Results

EUT: Car Stereo/Video with AM/FM/WXA/DVD/USB/BT			
M/N: MS30BT			
Test date: 2014-03-26		Pressure: 101.2±1.0 kpa	Humidity: 51.9±1.0%
Tested by: Eric		Test site: RF site	Temperature:23.2±1.0 °C
Cable loss: 1.0dB			
Test Mode	CH (MHz)	Peak output Power (dBm)	Limit (dBm)
GFSK	2402	3.858	30
	2441	0.346	30
	2480	-2.206	30
Conclusion: PASS			

GFSK
2402MHz

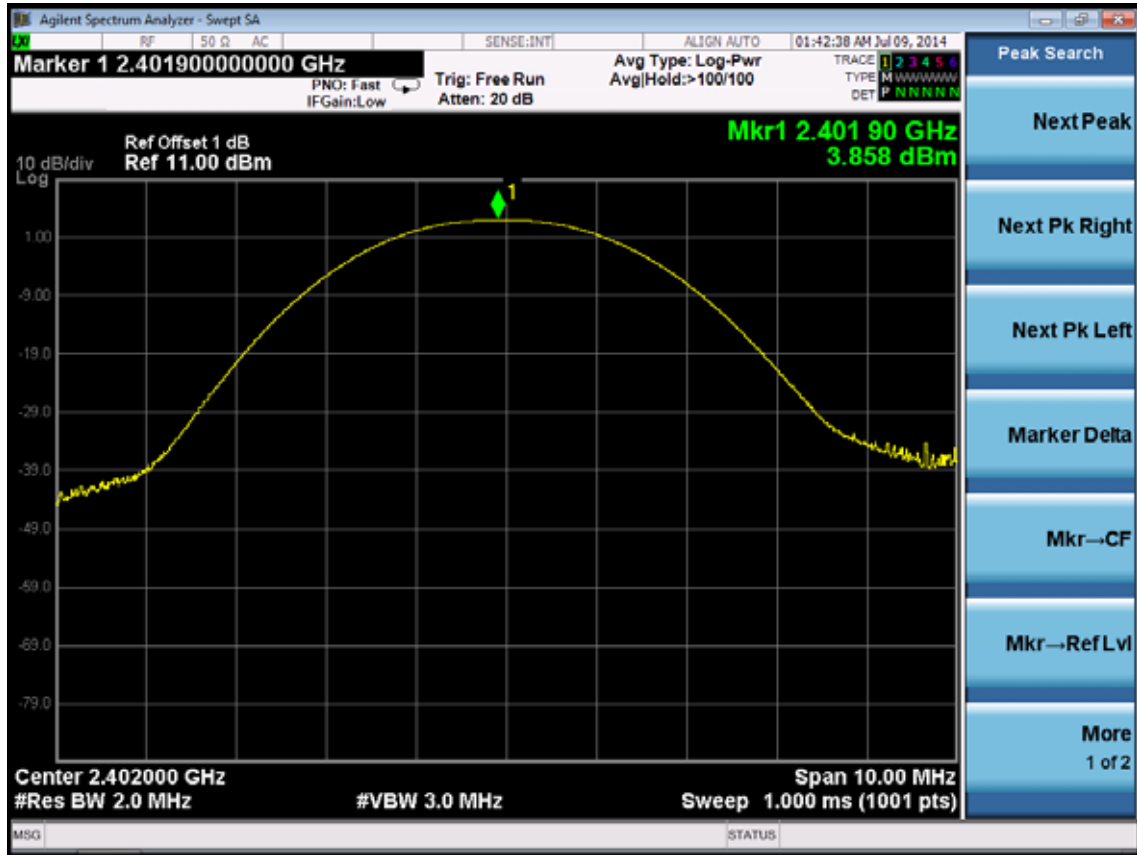

2441MHz

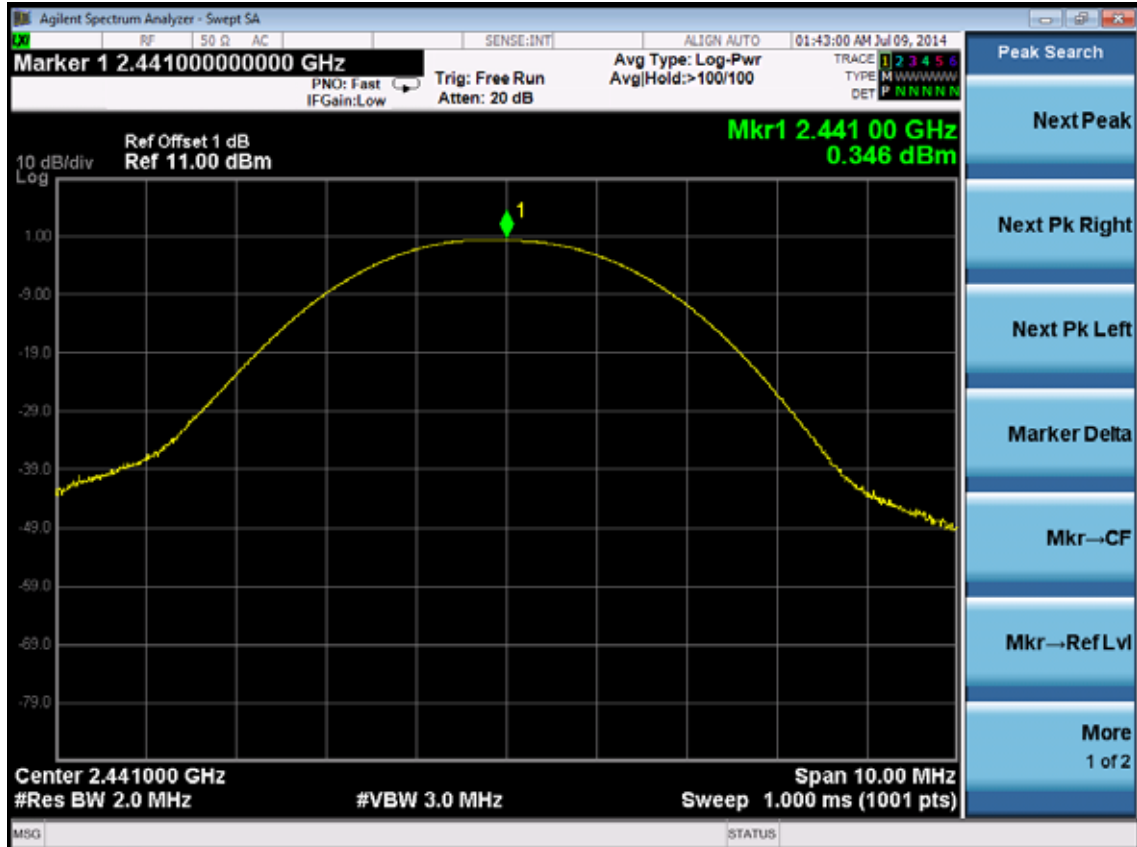

2480MHz

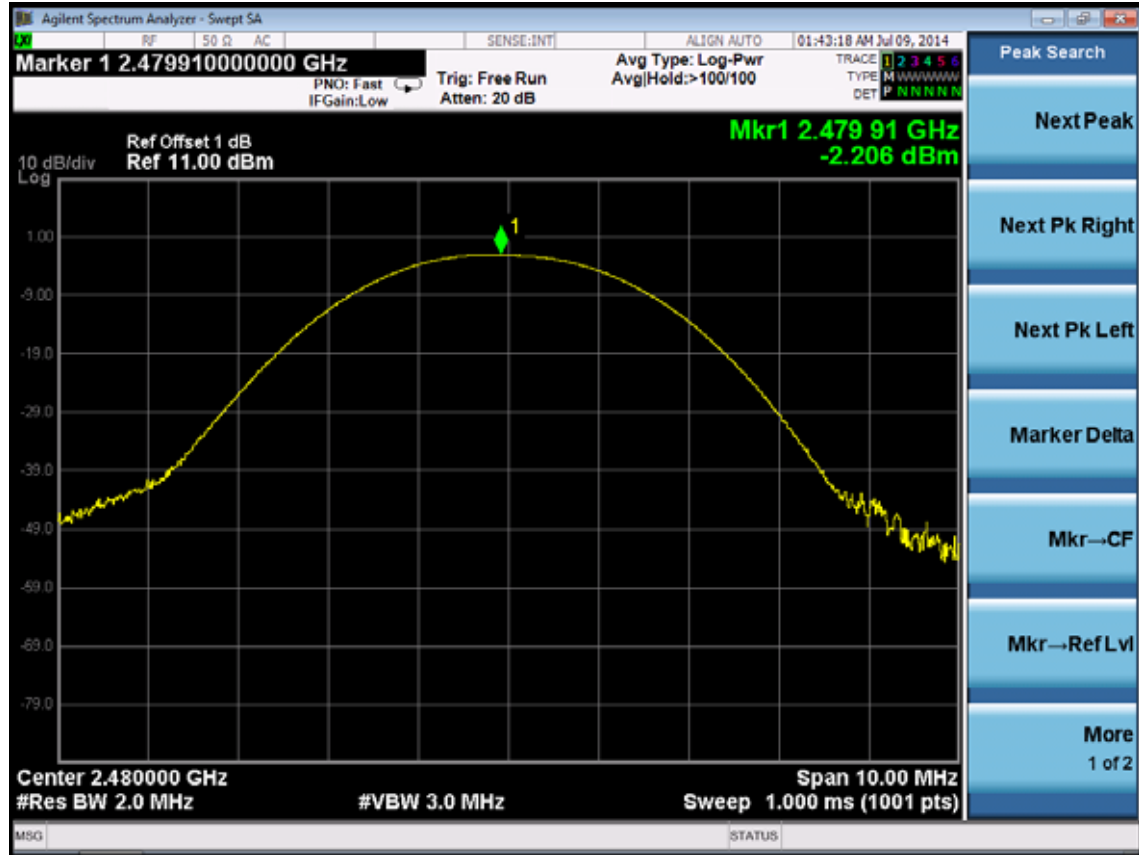

11. BAND EDGE COMPLIANCE TEST

11.1. Test Equipment

Item	Equipment	Manufacturer	Model No.	Serial No.	Last Cal.	Cal. Interval
1.	Spectrum	Agilent	E4446A	US44300459	Apr. 28,14	1 Year
2.	Amp	HP	8449B	3008A02495	Apr. 28,14	1 Year
3.	Horn Antenna	ETS	3115	9510-4580	Jun. 06, 14	1 Year
4.	HF Cable	Hubersuhner	Sucoflex104	274094/4	Apr. 28,14	1 Year
5	RF Cable	Hubersuhner	Sucoflex102	28610/2	Apr. 28,14	1 Year

11.2. Limit

All the lower and upper band-edges emissions appearing within 2310MHz to 2390MHz and 2483.5MHz to 2500MHz restricted frequency bands shall not exceed the limits shown in 15.209, all the other emissions outside operation frequency band 2400MHz to 2483.5MHz shall be at least 20dB below the fundamental emissions, or comply with 15.209 limits.

11.3. Test Produce

For upper band emissions that are up to two bandwidths(2MHz) away (2483.5MHz to 2485.5MHz) from the band-edge use below produce:

1. Choose a spectrum analyzer span that encompasses both the peak of the fundamental emission and the band-edge emission under investigation. Set the analyzer RBW to 100KHz and with a video bandwidth 300KHz. Record the peak levels of the fundamental emission and the relevant band-edge emission, Observe the stored trace and measure the amplitude delta between the peak of the fundamental and the peak of the band-edge emission. This is not a field strength measurement, it is only a relative measurement to determine the amount by which the emission drops at the band edge relative to the highest fundamental emission level.
2. Subtract the delta measured in step (1) from the maximum field strengths measured in clause 4 .The resultant field strengths are then used to determine band-edge compliance as required by Section 15.205

For emissions above two bandwidths away from the band-edge use below produce:

1. The EUT is placed on a turntable, which is 0.8m above the ground plane and worked at highest radiated power.
2. The turntable was rotated for 360 degrees to determine the position of maximum emission level.
3. EUT is set 3m away from the receiving antenna, which is varied from 1m to 4m to find out the highest emission.
4. Set the spectrum analyzer in the following setting in order to capture the lower and upperband-edges of the emission:
 - (a) PEAK: RBW=1MHz ;VBW=3MHz, PK detector, Sweep=AUTO
 - (b) This is pulse Modulation device a duty cycle factor was used to calculate average level based measured peak level.

11.4. Test Results

Pass (The testing data was attached in the next pages.)

Note: If the PK measured levels comply with average limit, then the average level were deemed to comply with average limit.

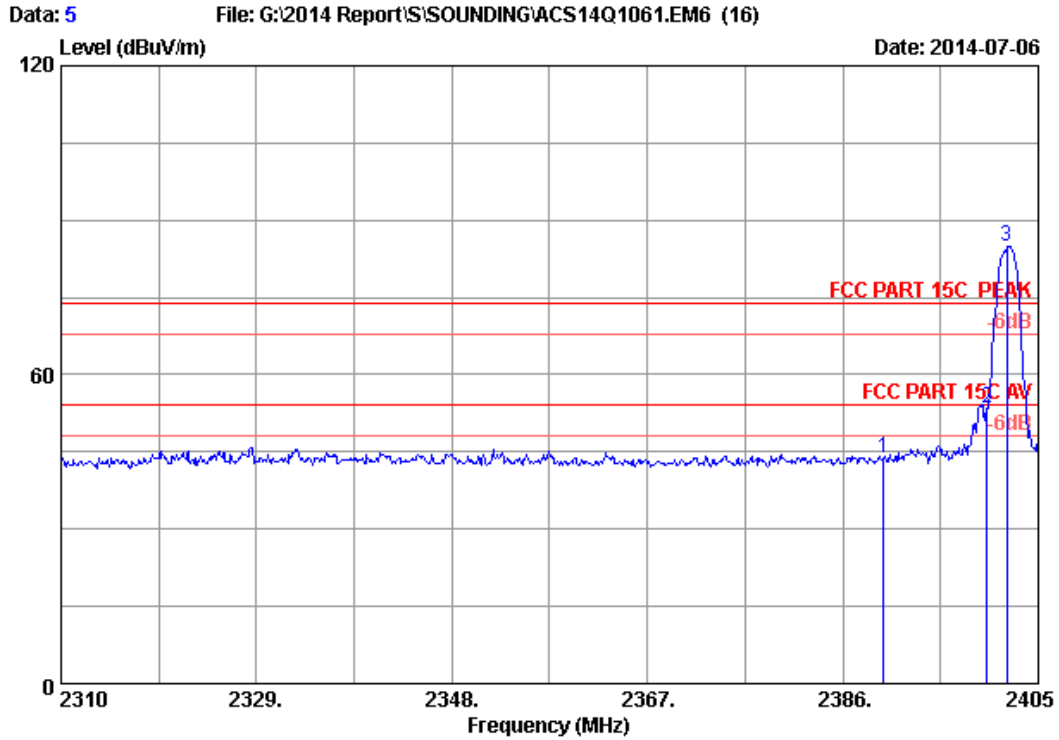

Site no. : 10m Chamber Data no. : 5
 Dis. / Ant. : 3m 2013 3115 (4580) Ant. pol. : HORIZONTAL
 Limit : FCC PART 15C PEAK
 Env. / Ins. : 24*C/56% Engineer : Eric
 EUT : Car Stereo/Video with AM/FM/WXA/DVD/USB/BT
 Power rating : DC 3V
 Test Mode : GFSK 2402MHz Tx
 JWM990

No.	Freq. (MHz)	Ant. Factor (dB/m)	Cable Loss (dB)	Reading (dBuV)	Emission Level (dBuV/m)	Limits (dBuV/m)	Margin (dB)	Remark
1	2390.000	28.16	6.43	44.85	43.74	74.00	30.26	Peak
2	2400.000	28.18	6.43	54.50	53.41	74.00	20.59	Peak
3	2401.960	28.18	6.43	86.10	85.01	74.00	-11.01	Peak

Remarks: 1. Emission Level= Antenna Factor + Cable Loss + Reading.
 2. The emission levels that are 20dB below the official limit are not reported.

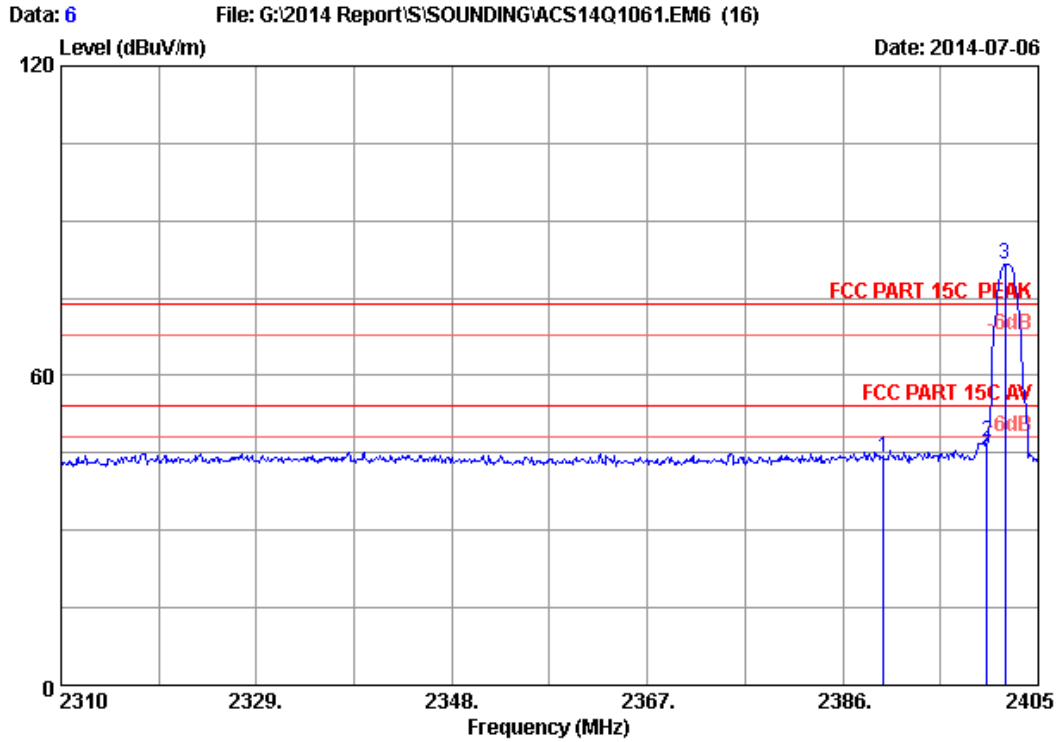

Site no. : 10m Chamber Data no. : 6
 Dis. / Ant. : 3m 2013 3115 (4580) Ant. pol. : VERTICAL
 Limit : FCC PART 15C PEAK
 Env. / Ins. : 24°C/56% Engineer : Eric
 EUT : Car Stereo/Video with AM/FM/WXA/DVD/USB/BT
 Power rating : DC 3V
 Test Mode : GFSK 2402MHz Tx
 JWM990

No.	Freq. (MHz)	Ant. Factor (dB/m)	Cable Loss (dB)	Reading (dBuV)	Emission Level (dBuV/m)	Limits (dBuV/m)	Margin (dB)	Remark
1	2390.000	28.16	6.43	45.32	44.21	74.00	29.79	Peak
2	2400.000	28.18	6.43	48.26	47.17	74.00	26.83	Peak
3	2401.770	28.18	6.43	82.57	81.48	74.00	-7.48	Peak

Remarks: 1. Emission Level= Antenna Factor + Cable Loss + Reading.
 2. The emission levels that are 20dB below the official limit are not reported.

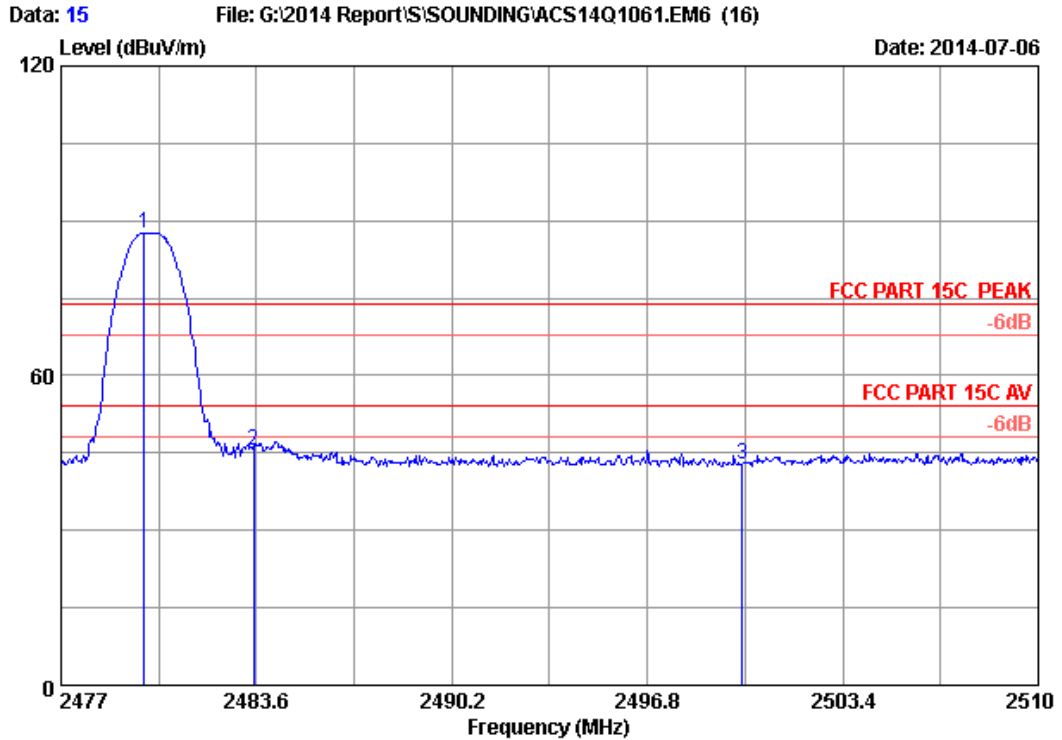

Site no. : 10m Chamber Data no. : 15
 Dis. / Ant. : 3m 2013 3115 (4580) Ant. pol. : HORIZONTAL
 Limit : FCC PART 15C PEAK
 Env. / Ins. : 24°C/56% Engineer : Eric
 EUT : Car Stereo/Video with AM/FM/WXA/DVD/USB/BT
 Power rating : DC 3V
 Test Mode : GFSK 2480MHz Tx
 JWM990

No.	Freq. (MHz)	Ant. Factor (dB/m)	Cable Loss (dB)	Reading (dBuV)	Emission Level (dBuV/m)	Limits (dBuV/m)	Margin (dB)	Remark
1	2479.805	28.36	6.46	88.53	87.65	74.00	-13.65	Peak
2	2483.500	28.36	6.46	46.35	45.47	74.00	28.53	Peak
3	2500.000	28.40	6.46	43.48	42.64	74.00	31.36	Peak

Remarks: 1. Emission Level= Antenna Factor + Cable Loss + Reading.
 2. The emission levels that are 20dB below the official limit are not reported.

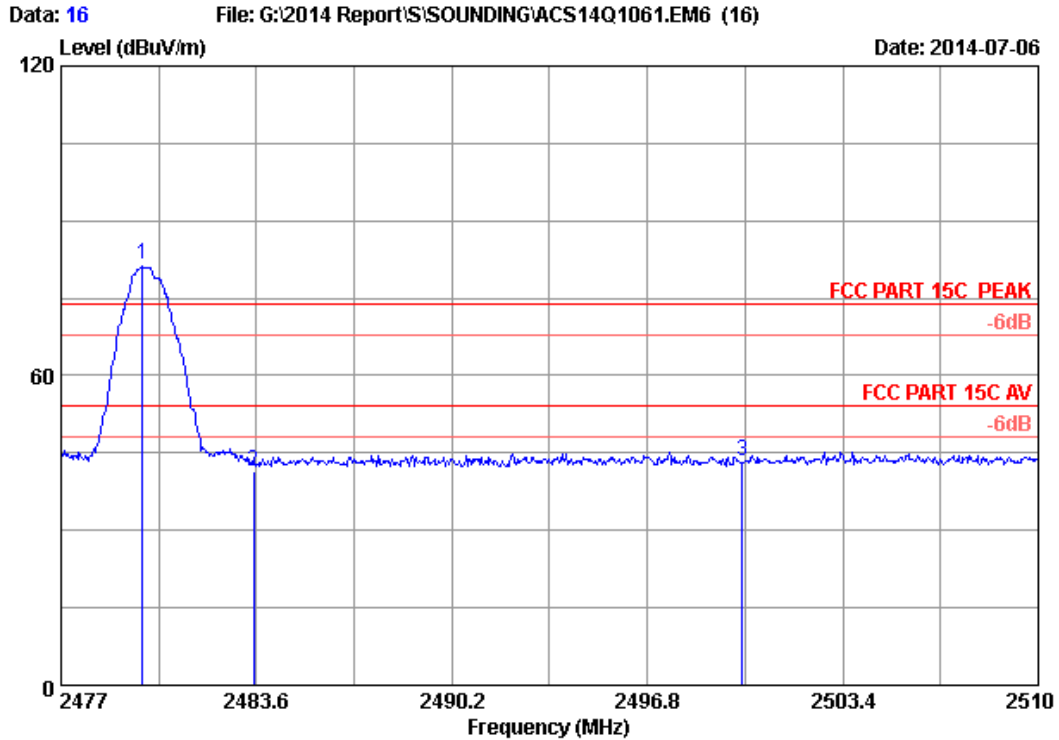

Site no. : 10m Chamber Data no. : 16
 Dis. / Ant. : 3m 2013 3115 (4580) Ant. pol. : VERTICAL
 Limit : FCC PART 15C PEAK
 Env. / Ins. : 24°C/56% Engineer : Eric
 EUT : Car Stereo/Video with AM/FM/WXA/DVD/USB/BT
 Power rating : DC 3V
 Test Mode : GFSK 2480MHz Tx
 JWM990

No.	Freq. (MHz)	Ant. Factor (dB/m)	Cable Loss (dB)	Reading (dBuV)	Emission Level (dBuV/m)	Limits (dBuV/m)	Margin (dB)	Remark
1	2479.739	28.36	6.46	82.35	81.47	74.00	-7.47	Peak
2	2483.500	28.36	6.46	42.25	41.37	74.00	32.63	Peak
3	2500.000	28.40	6.46	44.13	43.29	74.00	30.71	Peak

Remarks: 1. Emission Level= Antenna Factor + Cable Loss + Reading.
 2. The emission levels that are 20dB below the official limit are not reported.

12.DEVIATION TO TEST SPECIFICATIONS

[NONE]