



**FCC PART 15C TEST REPORT FOR CERTIFICATION  
On Behalf of**

**Sounding Audio Industrial Ltd.**

**Mobile wall mount unit**

**JWM1A**

**FCC ID: OPDJWM1ABK**

Prepared for : Sounding Audio Industrial Ltd.  
Unit N, 7/F, Stage 2. Wah Fung Industrial Centre 33-39 Kw  
Chung Road Kwai Chung, Hong Kong

Prepared By : Audix Technology (Shenzhen) Co., Ltd.  
No. 6, Kefeng Road, Science & Technology Park, Nanshan  
District , Shenzhen, Guangdong, China

Tel: (0755) 26639496

Report Number : ACS-F16176  
Date of Test : Aug.16~26, 2016  
Date of Report : Sep.07, 2016

**TABLE OF CONTENTS**

| <u>Description</u>  | <u>Page</u> |
|---|-------------|
| <b>1. SUMMARY OF STANDARDS AND RESULTS .....</b>                | <b>1-1</b>  |
| 1.1. Description of Standards and Results.....                  | 1-1         |
| <b>2. GENERAL INFORMATION.....</b>                              | <b>2-1</b>  |
| 2.1. Description of Device (EUT) .....                          | 2-1         |
| 2.2. Test information .....                                     | 2-2         |
| 2.3. Tested Supporting System Details .....                     | 2-2         |
| 2.4. Block Diagram of Test Setup .....                          | 2-2         |
| 2.5. Test Facility.....   | 2-3         |
| 2.6. Measurement Uncertainty (95% confidence levels, k=2) ..... | 2-3         |
| <b>3. POWER LINE CONDUCTED EMISSION TEST.....</b>               | <b>3-1</b>  |
| <b>4. RADIATED EMISSION MEASUREMENT .....</b>                   | <b>4-1</b>  |
| 4.1. Test Equipment .....                                       | 4-1         |
| 4.2. Block Diagram of Test Setup .....                          | 4-2         |
| 4.3. Radiated Emission Limit Standard: FCC 15.209 .....         | 4-3         |
| 4.4. EUT Configuration on Test.....                             | 4-3         |
| 4.5. Operating Condition of EUT.....                            | 4-3         |
| 4.6. Test Procedure.....  | 4-3         |
| 4.7. Radiated Emission Test Results .....                       | 4-4         |
| <b>5. CONDUCTED SPURIOUS EMISSIONS .....</b>                    | <b>5-1</b>  |
| 5.1. Test Equipment .....                                       | 5-1         |
| 5.2. Limit.....   | 5-1         |
| 5.3. Test Procedure.....  | 5-1         |
| 5.4. Test result .....  | 5-1         |
| <b>6. CARRIER FREQUENCY SEPARATION TEST .....</b>               | <b>6-1</b>  |
| 6.1. Test Equipment .....                                       | 6-1         |
| 6.2. Limit.....   | 6-1         |
| 6.3. Test Results .....   | 6-1         |
| <b>7. 20 DB BANDWIDTH TEST .....</b>                            | <b>7-1</b>  |
| 7.1. Test Equipment .....                                       | 7-1         |
| 7.2. Limit.....   | 7-1         |
| 7.3. Test Results .....   | 7-1         |
| <b>8. NUMBER OF HOPPING FREQUENCY TEST .....</b>                | <b>8-1</b>  |
| 8.1. Test Equipment .....                                       | 8-1         |
| 8.2. Limit.....   | 8-1         |
| 8.3. Test Results .....   | 8-1         |
| <b>9. DWELL TIME.....</b>                                       | <b>9-1</b>  |
| 9.1. Test Equipment .....                                       | 9-1         |
| 9.2. Limit.....   | 9-1         |
| 9.3. Test Results .....   | 9-1         |
| <b>10. MAXIMUM PEAK OUTPUT POWER TEST.....</b>                  | <b>10-1</b> |
| 10.1. Test Equipment .....                                      | 10-1        |
| 10.2. Limit.....  | 10-1        |
| 10.3. Test Procedure.....                                       | 10-1        |
| 10.4. Test Results .....  | 10-1        |

|            |   |             |
|------------|---|-------------|
| <b>11.</b> | <b>BAND EDGE COMPLIANCE TEST .....</b>        | <b>11-1</b> |
| 11.1.      | Test Equipment .....                          | 11-1        |
| 11.2.      | Limit.....                                    | 11-1        |
| 11.3.      | Test Produce .....                            | 11-1        |
| 11.4.      | Test Results .....                            | 11-1        |
| <b>12.</b> | <b>DEVIATION TO TEST SPECIFICATIONS .....</b> | <b>12-1</b> |
| <b>13.</b> | <b>PHOTOGRAPH OF TEST.....</b>                | <b>13-1</b> |
| 13.1.      | Photos of Radiated Emission Test.....         | 13-1        |
| <b>14.</b> | <b>PHOTOS OF THE EUT .....</b>                | <b>14-1</b> |



FCC ID: OPDJWM1ABK

TEST REPORT CERTIFICATION

Applicant : Sounding Audio Industrial Ltd.  
 Manufacturer : AR Electronics Co., Ltd.  
 Product : Mobile wall mount unit  
 FCC ID : OPDJWM1ABK  
 (A) Model No. : JWM1A  
 (B) Serial No. : N/A  
 (C) Power Supply : DC 12V  
 (D) Test Voltage : DC 12V

Tested for comply with:  
 FCC Rules and Regulations Part 15 Subpart C: 2014  
 Test procedure used:  
 ANSI C63.10: 2013

The device described above is tested by AUDIX TECHNOLOGY (SHENZHEN) CO., LTD. to confirm comply with all the FCC Part 15 Subpart C requirements. The test results are contained in this test report and AUDIX TECHNOLOGY (SHENZHEN) CO., LTD. is assumed full responsibility for the accuracy and completeness of these tests. Also, this report shows that the Equipment Under Test (EUT) is to be technically compliant with the FCC and IC requirements. This report contains data that are not covered by the NVLAP accreditation.

This Report is made under FCC Part 2.1075. No modifications were required during testing to bring this product into compliance.

This report applies to above tested sample only. This report shall not be reproduced in part without written approval of AUDIX TECHNOLOGY (SHENZHEN) CO., LTD.

The report must not be used by the client to claim product certification, approval, or endorsement by NVLAP, NIST, or any agency of the federal government.

Date of Test : Aug.16~26, 2016 Report of date: Sep.07, 2016

Prepared by : Cindy Zhu Reviewed by : Sunny Lu  
 Cindy Zhu / Assistant Sunny Lu / Deputy Manager



Approved & Authorized Signer : David Jin  
 David Jin / Manager

## 1. SUMMARY OF STANDARDS AND RESULTS

### 1.1. Description of Standards and Results

The EUT has been tested according to the applicable standards as referenced below.

| EMISSION                           |   |         |
|------------------------------------|---|---------|
| Description of Test Item           | Standard  | Results |
| Power Line Conducted Emission Test | FCC Part 15: 15.207<br>ANSI C63.10 : 2013                           | N/A     |
| Radiated Emission Test             | FCC Part 15: 15.209<br>FCC Part 15: 15.247(d)<br>ANSI C63.10 : 2013 | PASS    |
| Conducted Spurious Emissions       | FCC Part 15: 15.247(a)(1)<br>ANSI C63.10 : 2013                     | PASS    |
| Carrier Frequency Separation Test  | FCC Part 15: 15.247(a)(1)<br>ANSI C63.10 : 2013                     | PASS    |
| 20dB Bandwidth Test                | FCC Part 15: 15.215<br>ANSI C63.10 : 2013                           | PASS    |
| Number Of Hopping Frequency Test   | FCC Part 15: 15.247(a)(1)(iii)<br>ANSI C63.10 : 2013                | PASS    |
| Dwell Time Test                    | FCC Part 15: 15.247(a)(1)(iii)<br>ANSI C63.10 : 2013                | PASS    |
| Maximum Peak Output Power Test     | FCC Part 15: 15.247(b)(1)\<br>ANSI C63.10 : 2013                    | PASS    |
| Band Edge Compliance Test          | FCC Part 15: 15.247(d)<br>ANSI C63.10 : 2013                        | PASS    |

## 2. GENERAL INFORMATION

### 2.1. Description of Device (EUT)

|                       |   |
|-----------------------|---|
| Product               | : Mobile wall mount unit  |
| Model No.             | : JWM1A   |
| FCC ID                | : OPDJWM1ABK  |
| Radio                 | : Bluetooth V2.1 + EDR  |
| Operation frequency   | : 2402-2480MHz  |
| Channel Number        | : 79 channels   |
| Modulation Technology | : GFSK, $\pi/4$ DQPSK, 8-DPSK   |
| Antenna Type          | : PCB antenna, 0dBi PK Gain   |
| Applicant             | : Sounding Audio Industrial Ltd.<br>Unit N, 7/F, Stage 2. Wah Fung Industrial Centre 33-39<br>Kw Chung Road Kwai Chung, Hong Kong |
| Manufacturer          | : AR Electronics Co., Ltd.<br>Sima District, Changping, Dongguan, Guangdong.  |
| Date of Test          | : Aug.16~26, 2016   |
| Date of Receipt       | : Aug.14, 2016  |
| Sample Type           | : Prototype production  |

### 2.2. Test information

A special test software was used to control EUT work in Continuous TX mode, and select test channel.

| Tested mode, channel, and data rate information |                  |              |                 |
|---|------------------|--------------|-----------------|
| Mode  | data rate (Mbps) | Channel      | Frequency (MHz) |
| Tx Mode<br>GFSK<br>modulation                   | 1                | Low :CH 0    | 2402            |
|   | 1                | Middle: CH39 | 2441            |
|   | 1                | High: CH78   | 2480            |
| Tx Mode<br>8-DPSK<br>modulation                 | 3                | Low :CH 0    | 2402            |
|   | 3                | Middle: CH39 | 2441            |
|   | 3                | High: CH78   | 2480            |

Note:  $\pi/4$ DQPSK modulation is same type modulation with 8-DPSK, and according exploratory test, 8-DPSK will have worse emissions, so the final test were only performed with GFSK and 8-DPSK modulation.

### 2.3. Tested Supporting System Details

| No. | Description | ACS No.                             | Manufacturer | Model     | Serial Number |
|-----|-------------|-------------------------------------|--------------|-----------|---------------|
| 1   | Speaker #1  | N/A                                 | SAMSUNG      | PS-E460D  | N/A           |
|     |             | Cable: Shielded, Undetachable, 0.9m |              |           |               |
| 2   | Speaker #2  | N/A                                 | SONY         | SS-CEX100 | N/A           |
|     |             | Cable: Shielded, Undetachable, 0.9m |              |           |               |
| 3   | MP4 Play    | N/A                                 | SONY         | NWZ-E360  | N/A           |

### 2.4. Block Diagram of Test Setup

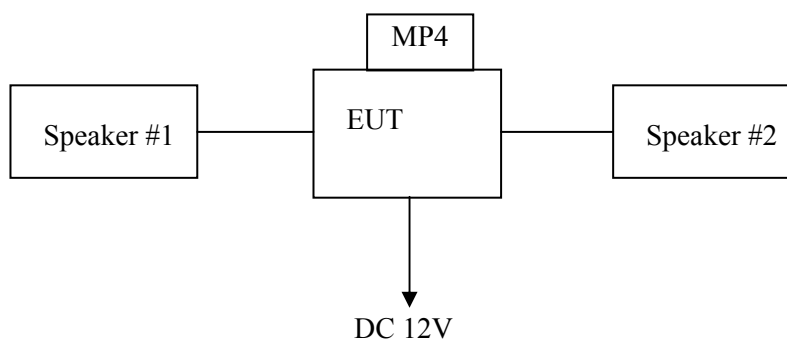

(EUT: Mobile wall mount unit)

**2.5. Test Facility**

Site Description

- Name of Firm : Audix Technology (Shenzhen) Co., Ltd.  
 No. 6, Kefeng Road, Science & Technology Park, Nanshan District, Shenzhen, Guangdong, China
- 3m Anechoic Chamber : Certificated by FCC, USA  
 Registration Number: 90454  
 Valid Date: Jul.12, 2017
- 3m & 10m Anechoic Chamber : Certificated by FCC, USA  
 Registration Number: 794232  
 Valid Date: Jul.12, 2017
- EMC Lab. : Certificated by Industry Canada  
 Registration Number: IC 5183A-1  
 Valid Date: May.14, 2017
- : Certificated by DAkkS, Germany  
 Registration No: D-PL-12151-01-00  
 Valid Date: Dec.15, 2016
- : Accredited by NVLAP, USA  
 NVLAP Code: 200372-0  
 Valid Date: Mar.31, 2017

**2.6. Measurement Uncertainty (95% confidence levels, k=2)**

| Test Item  | Uncertainty                       |
|--|-----------------------------------|
| Uncertainty for Radiation Emission test in 3m chamber              | 2.8dB(30~200MHz, Polarization: H) |
|  | 2.8dB(30~200MHz, Polarization: V) |
|  | 2.8dB(200M~1GHz, Polarization: H) |
|  | 2.8dB(200M~1GHz, Polarization: V) |
| Uncertainty for Radiation Emission test in 3m chamber (1GHz-18GHz) | 5.8dB (1~6GHz, Distance: 3m)      |
|  | 5.8dB (6~18GHz, Distance: 3m)     |
| Uncertainty for Radiated Spurious Emission test in RF chamber      | 3.6dB                             |
| Uncertainty for Conduction Spurious emission test                  | 2.0dB                             |
| Uncertainty for Output power test                                  | 0.8dB                             |
| Uncertainty for Bandwidth test                                     | 83kHz                             |
| Uncertainty for DC power test                                      | 0.1%                              |
| Uncertainty for test site temperature and humidity                 | 0.6                               |
|  | 3%                                |



### **3. POWER LINE CONDUCTED EMISSION TEST**

According to Paragraph (c) of FCC Part 15 section 15.207, Tests to demonstrate compliance with the conducted limits are not required for devices which only employ battery power for operation and which do not operate from the AC power lines or contain provisions for operation while connected to the AC power lines.

## 4. RADIATED EMISSION MEASUREMENT

### 4.1. Test Equipment

Frequency rang: 30~1000MHz (In 3m Anechoic Chamber)

| Item | Equipment                 | Manufacturer    | Model No.           | Serial No.      | Last Cal. | Cal. Interval |
|------|---------------------------|-----------------|---------------------|-----------------|-----------|---------------|
| 1.   | 3#Chamber                 | AUDIX           | N/A                 | N/A             | Mar.28,16 | 1 Year        |
| 2.   | EMI Spectrum              | Agilent         | E4407B              | MY41440292      | Apr.24,16 | 1 Year        |
| 3.   | Test Receiver             | Rohde & Schwarz | ESVS10              | 834468/011      | Apr.24,16 | 1 Year        |
| 4.   | Amplifier                 | HP              | 8447D               | 2648A04738      | Apr.24,16 | 1 Year        |
| 5.   | Tri-log-Broadband Antenna | SCHWARZBECK     | VULB 9168           | 9168-710        | JUL.20,16 | 1 Year        |
| 6.   | RF Cable                  | MIYAZAKI        | CFD400-N<br>W(3.5M) | No.3            | Apr.24,16 | 1 Year        |
| 7.   | RF Cable                  | MIYAZAKI        | CFD400-L<br>W(22M)  | No.7            | Apr.24,16 | 1 Year        |
| 8.   | Coaxial Switch            | Anritsu         | MP59B               | 6201397222      | Apr.23,16 | 1 Year        |
| 9.   | Test Software             | AUDIX           | e3                  | 6.2009-5-21a(n) | N/A       | N/A           |

Note: N/A means Not applicable.

#### 4.1.1. For frequency range 1GHz~25GHz (In 3m Anechoic Chamber)

| Item | Equipment         | Manufacturer | Model No.   | Serial No.      | Last Cal. | Cal. Interval |
|------|-------------------|--------------|-------------|-----------------|-----------|---------------|
| 1.   | Spectrum Analyzer | Agilent      | E4446A      | US44300459      | Apr.24,16 | 1 Year        |
| 2.   | Horn Antenna      | ETS          | 3115        | 9510-4877       | Oct.15,15 | 1 Year        |
| 3.   | Amplifier         | Agilent      | 8449B       | 3008A02495      | Apr.24,16 | 1 Year        |
| 4.   | RF Cable          | Hubersuhner  | SUCOFLEX104 | 274094/4        | Apr.24,16 | 1 Year        |
| 5.   | Horn Antenna      | ETS          | 3116        | 00060089        | Oct.15,15 | 1 Year        |
| 6.   | Test Software     | AUDIX        | e3          | 6.2009-5-21a(n) | N/A       | N/A           |

Note: N/A means Not applicable.

### 4.2. Block Diagram of Test Setup

For frequency range 30MHz-1000MHz

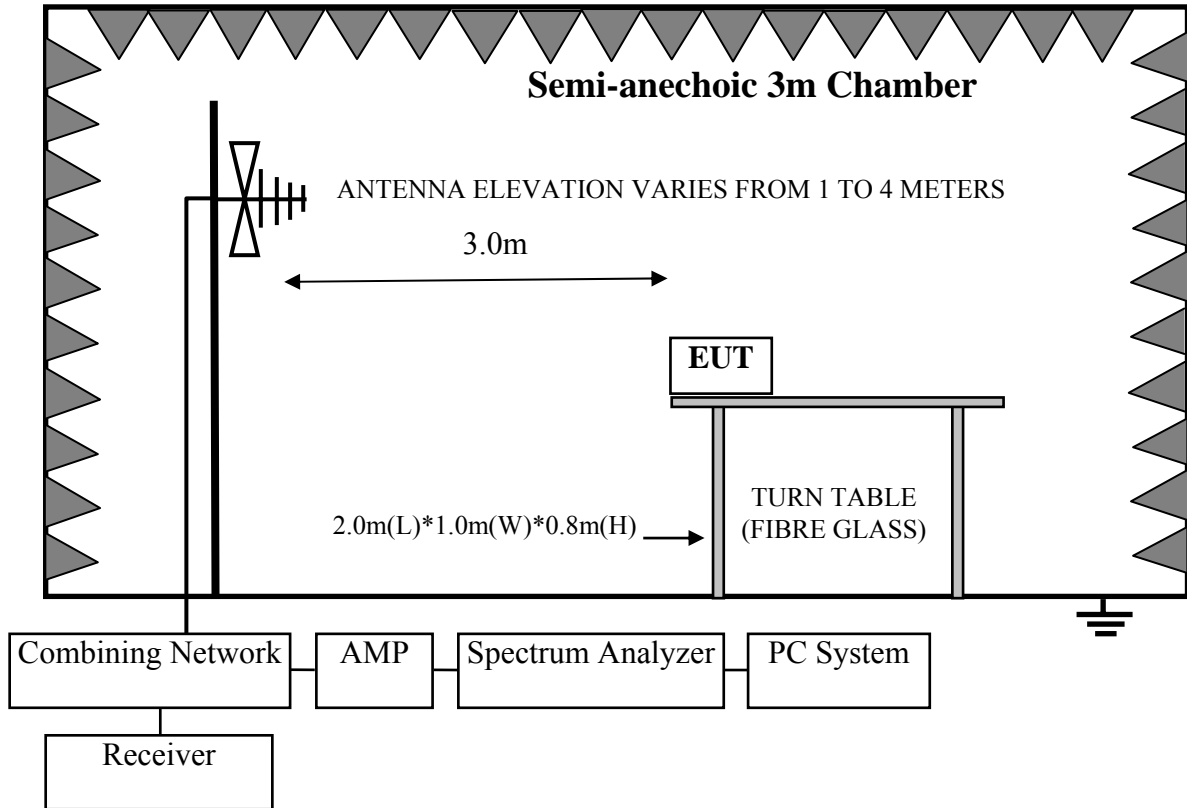

For frequency range 1GHz-25GHz

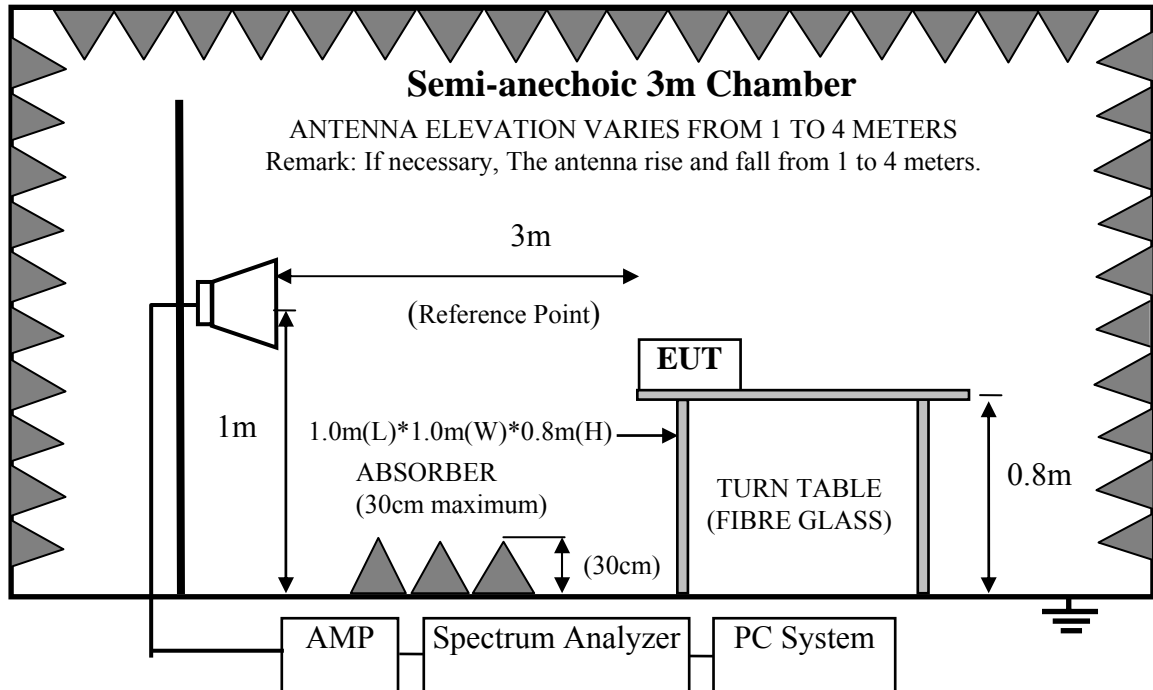

### 4.3. Radiated Emission Limit Standard: FCC 15.209

| FREQUENCY<br>MHz | DISTANCE<br>Meters | FIELD STRENGTHS LIMIT                           |          |
|------------------|--------------------|---|----------|
|                  |                    | μV/m  | dB(μV)/m |
| 30 ~ 88          | 3                  | 100   | 40.0     |
| 88 ~ 216         | 3                  | 150   | 43.5     |
| 216 ~ 960        | 3                  | 200   | 46.0     |
| 960 ~ 1000       | 3                  | 500   | 54.0     |
| Above 1000MHz    | 3                  | 74.0 dB(μV)/m (Peak)<br>54.0 dB(μV)/m (Average) |          |

Remark : (1) Emission level dBμV = 20 log Emission level μV/m

- (2) The smaller limit shall apply at the cross point between two frequency bands.
- (3) Distance is the distance in meters between the measuring instrument, antenna and the closest point of any part of the device or system.
- (4) The emission limits shown in the above table are based on measurements employing a CISPR quasi-peak detector except for the frequency bands 9-90 kHz, 110-490 kHz and above 1000 MHz. Radiated emission limits in these three bands are based on measurements employing an average detector.

### 4.4.EUT Configuration on Test

The following equipment are installed on Power Line Conducted Emission Test to meet the commission requirement and operating regulations in a manner which tends to maximize its emission characteristics in a normal application.

#### 4.4.1.Mobile wall mount unit (EUT)

Model Number: JWM1A

Serial Number: N/A

#### 4.4.2.Support Equipment: As Tested Supporting System Details, in Section 2.2.

### 4.5.Operating Condition of EUT

4.5.1.Setup the EUT and simulator as shown as Section 4.2.

4.5.2.Turn on the power of all equipments.

4.5.3.Let EUT work in Tx mode.

### 4.6.Test Procedure

EUT and its simulators are placed on a turn table, which is 0.8 meter high above ground for frequency 30MHz~1000MHz, 1.5 meter high above ground for frequency above 1GHz and put the absorbing with 2.4m(L)\*2.4m(W)\*0.3m(H) on the ground . The turn table can rotate 360 degrees to determine the position of the maximum emission level. Power on the EUT and let it working in test mode, then test it.EUT is set 3 meters away from the receiving antenna, which is mounted on a antenna tower. The antenna can be moved up and down between 1 meter and 4 meters to find out the maximum emission level. Broadband antenna (calibrated bilog antenna) is used as receiving antenna for frequency 30MHz~1000MHz, and the Horn antenna is used as receiving antenna for frequency above 1GHz. Both horizontal and vertical polarization of the antenna is set on Test. In order to find the maximum emission levels, all of the interface cables must be manipulated according to ANSI C63.10-2013 on radiated emission Test.

This test was performed with EUT in X, Y, Z position, and the worse case was found when EUT in X position as the test photo indicated.

The bandwidth of the EMI test receiver (R&S ESVS10) is set at 120kHz for frequency range from 30MHz to 1000 MHz.

The bandwidth of the Spectrum's RBW is set at 1MHz and VBW is set at 3MHz for peak emissions measurement above 1GHz

This device is pulse Modulated, a duty cycle factor was used to calculated average level based measured peak level.

The frequency range from 30MHz to 10th harmonic (25GHz) are checked. and no any emissions were found from 18GHz to 25 GHz, So the radiated emissions from 18GHz to 25GHz were not record.

#### 4.7.Radiated Emission Test Results

**PASS.**

All the emissions from 30MHz to 25GHz were complying with the 15.209 Limit.

Note1: We selected GFSK mode in low channel which is the worst case to record in the report for 30-1000MHz test item.

Note2: The duty cycle factor for calculate average level is -30.722 dB, and average limit is 20dB below peak limit, so if peak measured level comply with average limit, the average level was deemed to comply with average limit.

$$\text{Duty cycle factor} = 20\log (\text{Dwell time}/100\text{ms}) = -30.722$$

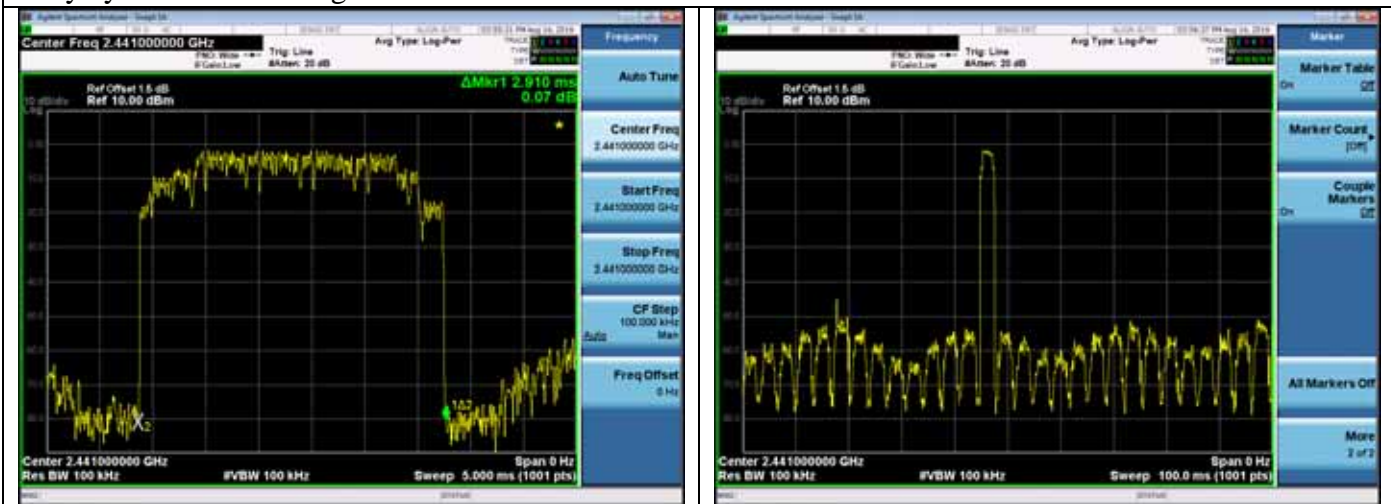

**Frequency: 30MHz~1GHz**

Data: 2

File: E:\2016 Report Data\S\Sounding\ACS16Q1238-RF.EM6 (6)

Date: 2016-08-20

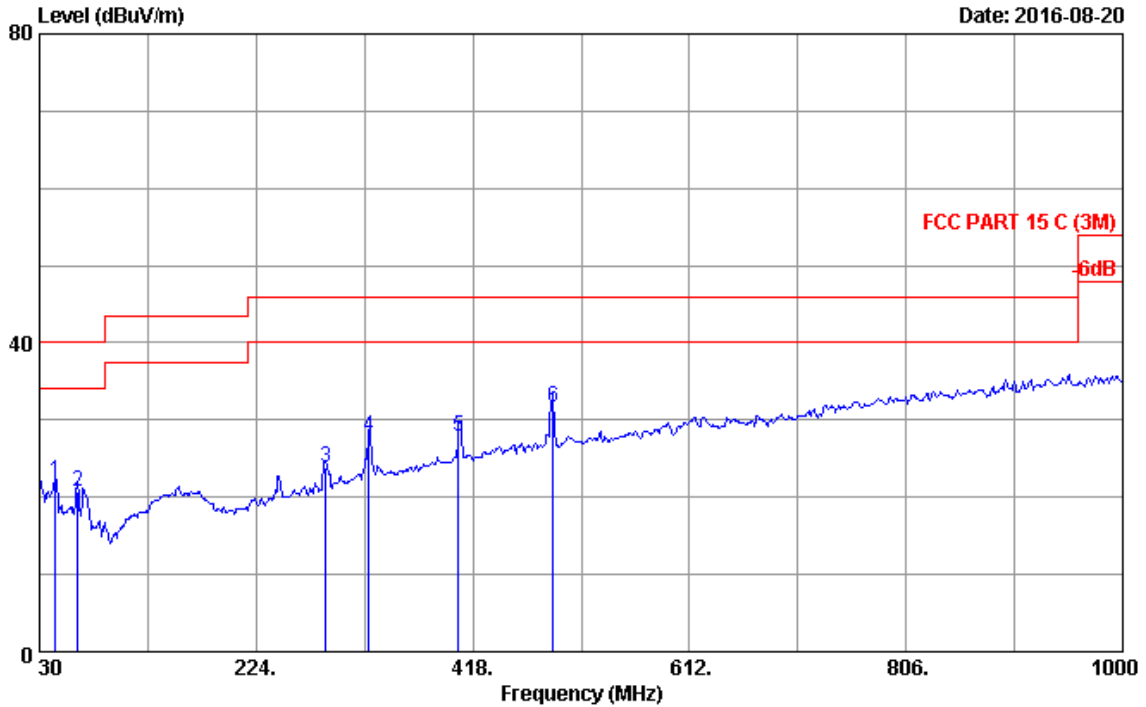

|              |                          |           |              |
|--------------|--------------------------|-----------|--------------|
| Site no.     | : 3m Chamber             | Data no.  | : 2          |
| Dis. / Ant.  | : 3m 2016 9168 710       | Ant. pol. | : HORIZONTAL |
| Limit        | : FCC PART 15 C (3M)     | Engineer  | : Donjon     |
| Env. / Ins.  | : 23.8.0°C/46%           |           |              |
| EUT          | : Mobile wall mount unit |           |              |
| Power rating | : DC 12V                 |           |              |
| Test Mode    | : Tx Mode                |           |              |
| M/N          | : JWM1A                  |           |              |

| No. | Freq. (MHz) | Ant. Factor (dB/m) | Cable Loss (dB) | Reading (dBUV) | Emission Level (dBUV/m) | Limits (dBUV/m) | Margin (dB) | Remark |
|-----|-------------|--------------------|-----------------|----------------|-------------------------|-----------------|-------------|--------|
| 1   | 44.550      | 20.42              | 0.79            | 0.81           | 22.02                   | 40.00           | 17.98       | QP     |
| 2   | 63.950      | 18.97              | 0.92            | 0.87           | 20.76                   | 40.00           | 19.24       | QP     |
| 3   | 286.080     | 19.53              | 1.96            | 2.32           | 23.81                   | 46.00           | 22.19       | QP     |
| 4   | 324.880     | 20.57              | 2.13            | 5.08           | 27.78                   | 46.00           | 18.22       | QP     |
| 5   | 405.390     | 22.18              | 2.47            | 3.25           | 27.90                   | 46.00           | 18.10       | QP     |
| 6   | 489.780     | 23.79              | 2.76            | 4.99           | 31.54                   | 46.00           | 14.46       | QP     |

Remarks: 1. Emission Level= Antenna Factor + Cable Loss + Reading.  
 2. The emission levels that are 20dB below the official limit are not reported.

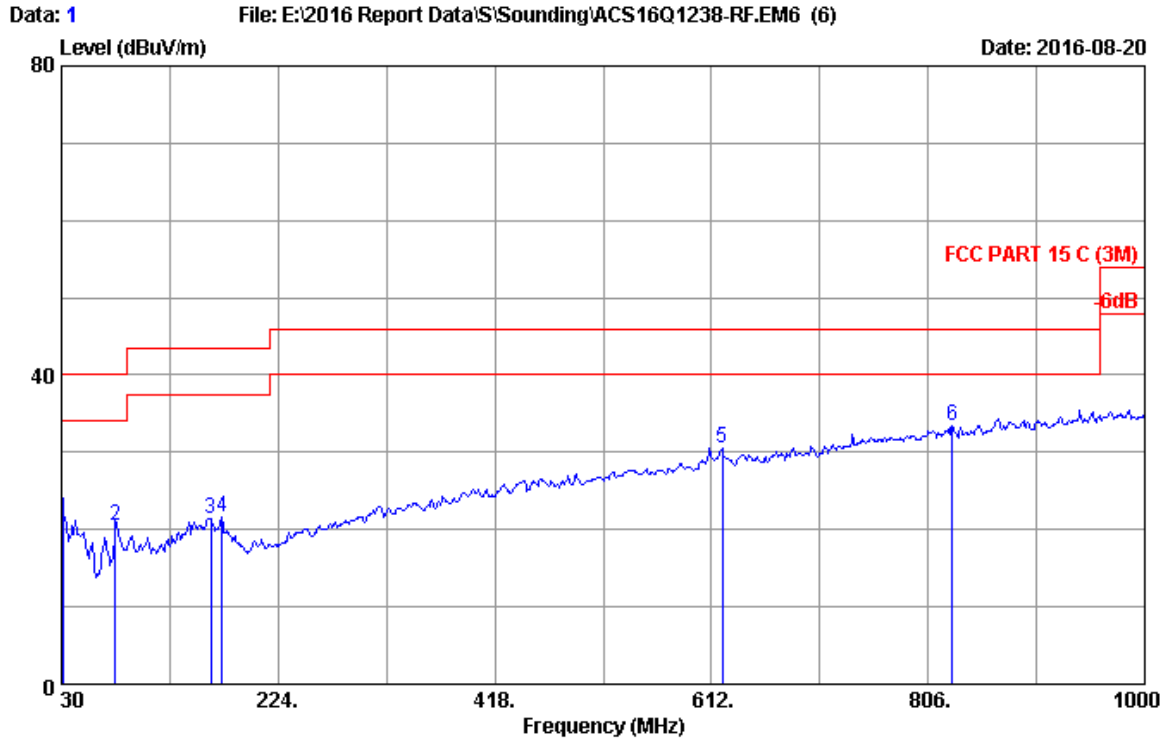

Site no. : 3m Chamber Data no. : 1  
 Dis. / Ant. : 3m 2016 9168 710 Ant. pol. : VERTICAL  
 Limit : FCC PART 15 C (3M)  
 Env. / Ins. : 23.8.0\*C/46% Engineer : Donjon  
 EUT : Mobile wall mount unit  
 Power rating : DC 12V  
 Test Mode : Tx Mode  
 M/N : JWM1A

| No. | Freq. (MHz) | Ant. Factor (dB/m) | Cable Loss (dB) | Reading (dBuV) | Emission Level (dBuV/m) | Limits (dBuV/m) | Margin (dB) | Remark |
|-----|-------------|--------------------|-----------------|----------------|-------------------------|-----------------|-------------|--------|
| 1   | 31.940      | 19.24              | 0.65            | 1.44           | 21.33                   | 40.00           | 18.67       | QP     |
| 2   | 78.500      | 15.57              | 0.99            | 3.84           | 20.40                   | 40.00           | 19.60       | QP     |
| 3   | 163.860     | 19.71              | 1.40            | 0.28           | 21.39                   | 43.50           | 22.11       | QP     |
| 4   | 173.560     | 19.37              | 1.44            | 0.75           | 21.56                   | 43.50           | 21.94       | QP     |
| 5   | 621.700     | 26.23              | 3.30            | 1.04           | 30.57                   | 46.00           | 15.43       | QP     |
| 6   | 827.340     | 28.47              | 4.27            | 0.74           | 33.48                   | 46.00           | 12.52       | QP     |

Remarks: 1. Emission Level= Antenna Factor + Cable Loss + Reading.  
 2. The emission levels that are 20dB below the official limit are not reported.

### Frequency: 1GHz~18GHz

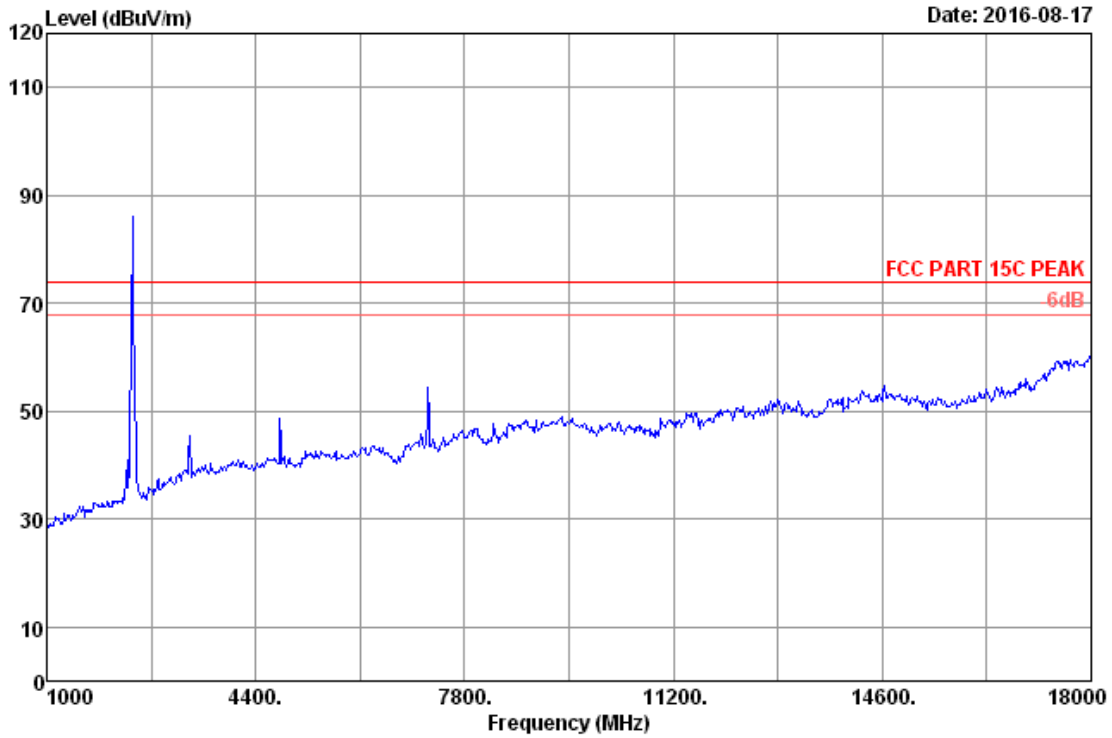

|              |                          |           |                |
|--------------|--------------------------|-----------|----------------|
| Site no.     | : RF Chamber             | Data no.  | : 1            |
| Dis. / Ant.  | : 3m 2015 3115-4877      | Ant. pol. | : HORIZONTAL   |
| Limit        | : FCC PART 15C PEAK      | Pre       | : 101.2kPa     |
| Env. / Ins.  | : 22.6°C/51.2%           | Engineer  | : Donjon_Huang |
| EUT          | : Mobile wall mount unit |           |                |
| Power rating | : DC 12V                 |           |                |
| Test Mode    | : GFSK 2402MHz Tx Mode   |           |                |
| M/N          | : JWM1A                  |           |                |



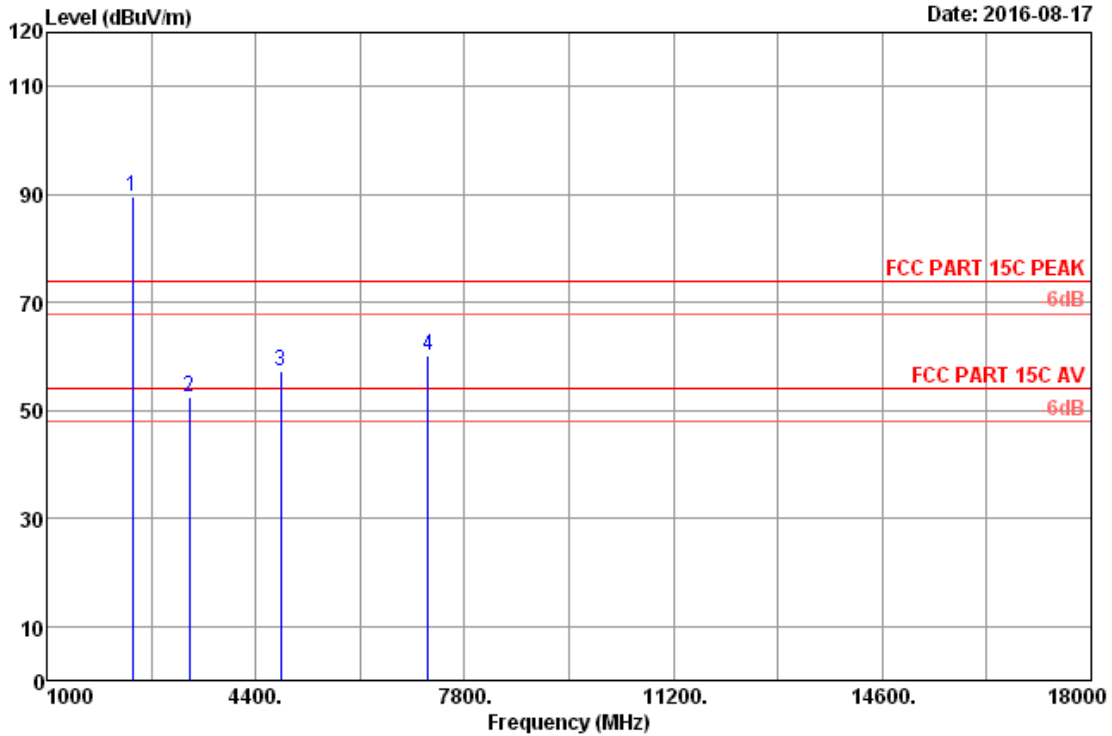

Site no. : RF Chamber  
 Dis. / Ant. : 3m 2015 3115-4877  
 Limit : FCC PART 15C PEAK  
 Env. / Ins. : 22.6°C/51.2%  
 EUT : Mobile wall mount unit  
 Power rating : DC 12V  
 Test Mode : GFSK 2402MHz Tx Mode  
 M/N : JWM1A

Data no. : 2  
 Ant. pol. : HORIZONTAL  
 Pre : 101.2kPa  
 Engineer : Donjon\_Huang

| No. | Freq. (MHz) | Ant. Factor (dB/m) | Cable Loss (dB) | Reading (dBuV) | AMP factor (dB) | Emission Level (dBuV/m) | Limits (dBuV/m) | Margin (dB) | Remark |
|-----|-------------|--------------------|-----------------|----------------|-----------------|-------------------------|-----------------|-------------|--------|
| 1   | 2402.00     | 28.28              | 8.34            | 89.39          | 36.39           | 89.62                   | 74.00           | -15.62      | Peak   |
| 2   | 3328.02     | 30.89              | 10.67           | 47.15          | 36.30           | 52.41                   | 74.00           | 21.59       | Peak   |
| 3   | 4804.00     | 33.11              | 11.75           | 48.07          | 35.67           | 57.26                   | 74.00           | 16.74       | Peak   |
| 4   | 7206.00     | 35.99              | 12.44           | 47.16          | 35.55           | 60.04                   | 74.00           | 13.96       | Peak   |

Remarks: 1. Emission Level= Antenna Factor + Cable Loss + Reading - Amp Factor  
 2. The emission levels that are 20dB below the official limit are not reported.

| Frequency ( MHz ) | Original AV level ( dBuV/m ) | Duty cycle factor (dB) | Final AV level (dBuV/m) | Limit(dBuv/m) | Conclusion |
|-------------------|------------------------------|------------------------|-------------------------|---------------|------------|
| 4804.00           | 57.26                        | -30.722                | 26.538                  | 54            | Pass       |
| 7206.00           | 60.04                        | -30.722                | 29.318                  | 54            | Pass       |

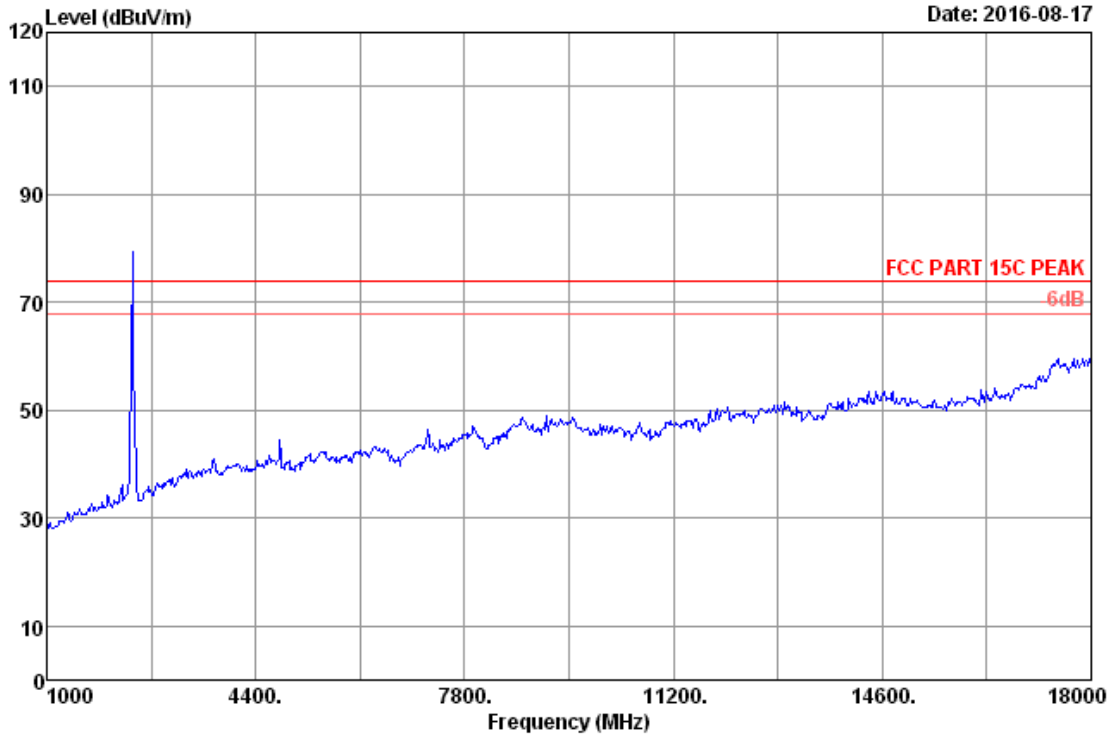

|                                  |                         |
|----------------------------------|-------------------------|
| Site no. : RF Chamber            | Data no. : 3            |
| Dis. / Ant. : 3m 2015 3115-4877  | Ant. pol. : VERTICAL    |
| Limit : FCC PART 15C PEAK        | Pre : 101.2kPa          |
| Env. / Ins. : 22.6*C/51.2%       | Engineer : Donjon_Huang |
| EUT : Mobile wall mount unit     |                         |
| Power rating : DC 12V            |                         |
| Test Mode : GFSK 2402MHz Tx Mode |                         |
| M/N : JWM1A                      |                         |

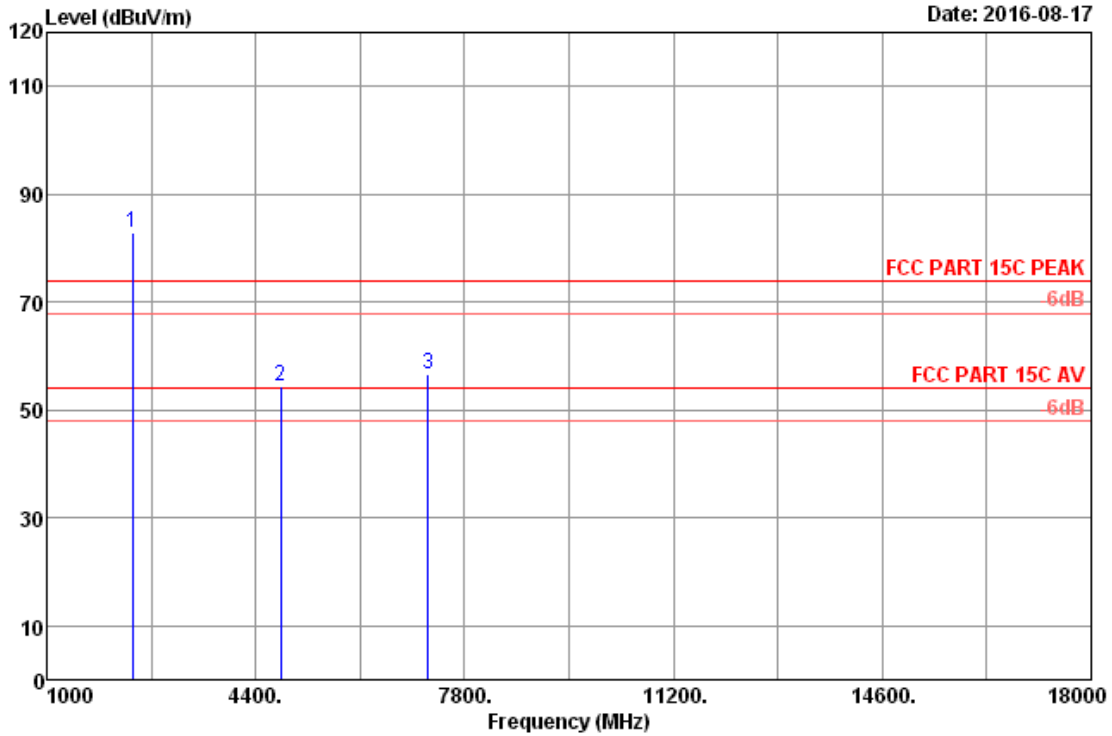

Date: 2016-08-17

Site no. : RF Chamber  
 Dis. / Ant. : 3m 2015 3115-4877  
 Limit : FCC PART 15C PEAK  
 Env. / Ins. : 22.6°C/51.2%  
 EUT : Mobile wall mount unit  
 Power rating : DC 12V  
 Test Mode : GFSK 2402MHz Tx Mode  
 M/N : JWM1A

Data no. : 4  
 Ant. pol. : VERTICAL  
 Pre : 101.2kPa  
 Engineer : Donjon\_Huang

| No. | Freq. (MHz) | Ant. Factor (dB/m) | Cable Loss (dB) | Reading (dBUV) | AMP factor (dB) | Emission Level (dBUV/m) | Limits (dBUV/m) | Margin (dB) | Remark |
|-----|-------------|--------------------|-----------------|----------------|-----------------|-------------------------|-----------------|-------------|--------|
| 1   | 2402.00     | 28.28              | 8.34            | 82.56          | 36.39           | 82.79                   | 74.00           | -8.79       | Peak   |
| 2   | 4804.00     | 33.11              | 11.75           | 45.11          | 35.67           | 54.30                   | 74.00           | 19.70       | Peak   |
| 3   | 7206.00     | 35.99              | 12.44           | 43.69          | 35.55           | 56.57                   | 74.00           | 17.43       | Peak   |

Remarks: 1. Emission Level= Antenna Factor + Cable Loss + Reading - Amp Factor  
 2. The emission levels that are 20dB below the official limit are not reported.

| Frequency ( MHz ) | Original AV level ( dBUV/m ) | Duty cycle factor (dB) | Final AV level (dBUV/m) | Limit(dBUV/m) | Conclusion |
|-------------------|------------------------------|------------------------|-------------------------|---------------|------------|
| 4804.00           | 54.30                        | -30.722                | 23.578                  | 54            | Pass       |
| 7206.00           | 56.57                        | -30.722                | 25.848                  | 54            | Pass       |

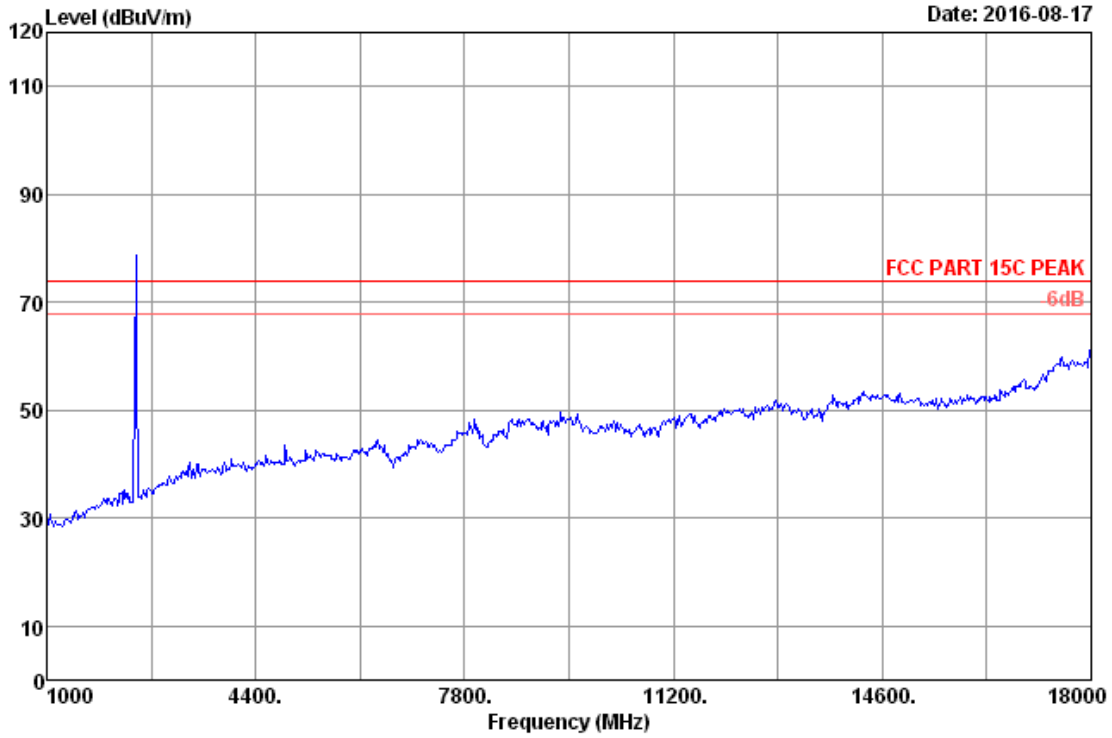

|              |                          |           |                |
|--------------|--------------------------|-----------|----------------|
| Site no.     | : RF Chamber             | Data no.  | : 7            |
| Dis. / Ant.  | : 3m 2015 3115-4877      | Ant. pol. | : VERTICAL     |
| Limit        | : FCC PART 15C PEAK      | Pre       | : 101.2kPa     |
| Env. / Ins.  | : 22.6*C/51.2%           | Engineer  | : Donjon_Huang |
| EUT          | : Mobile wall mount unit |           |                |
| Power rating | : DC 12V                 |           |                |
| Test Mode    | : GFSK 2441MHz Tx Mode   |           |                |
| M/N          | : JWM1A                  |           |                |

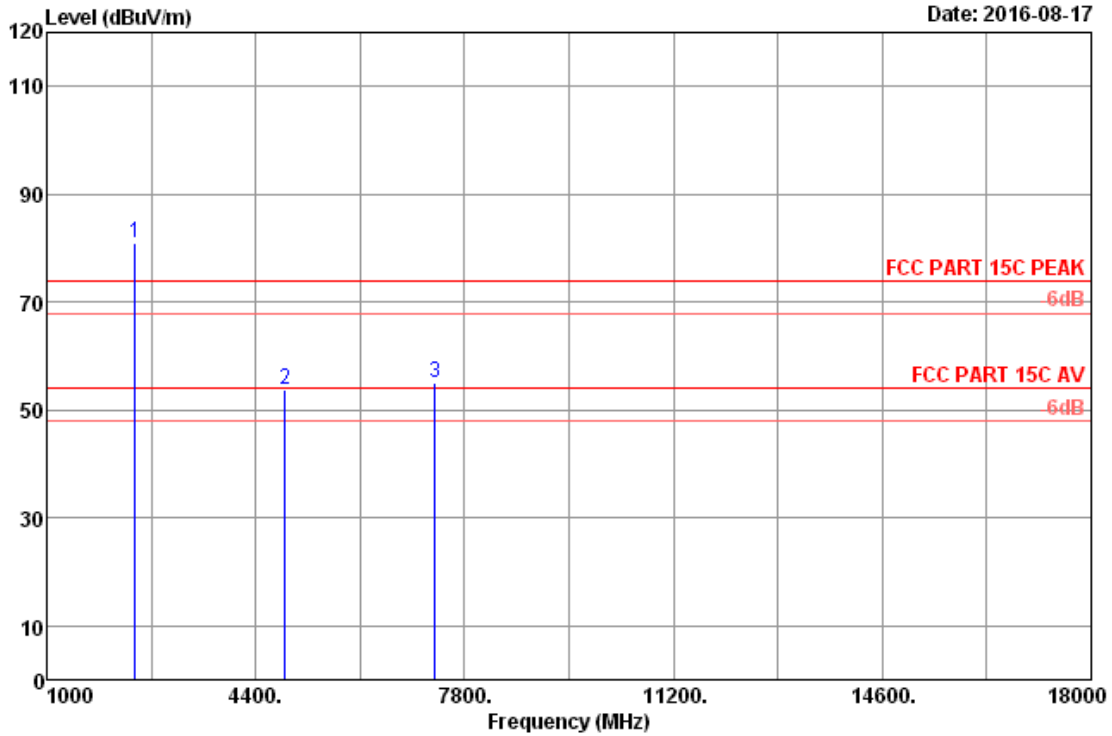

Site no. : RF Chamber Data no. : 8  
 Dis. / Ant. : 3m 2015 3115-4877 Ant. pol. : VERTICAL  
 Limit : FCC PART 15C PEAK Pre : 101.2kPa  
 Env. / Ins. : 22.6°C/51.2% Engineer : Donjon\_Huang  
 EUT : Mobile wall mount unit  
 Power rating : DC 12V  
 Test Mode : GFSK 2441MHz Tx Mode  
 M/N : JWM1A

| No. | Freq. (MHz) | Ant. Factor (dB/m) | Cable Loss (dB) | Reading (dBuV) | AMP factor (dB) | Emission Level (dBuV/m) | Limits (dBuV/m) | Margin (dB) | Remark |
|-----|-------------|--------------------|-----------------|----------------|-----------------|-------------------------|-----------------|-------------|--------|
| 1   | 2441.00     | 28.33              | 8.38            | 80.57          | 36.38           | 80.90                   | 74.00           | -6.90       | Peak   |
| 2   | 4882.00     | 33.26              | 11.80           | 44.41          | 35.69           | 53.78                   | 74.00           | 20.22       | Peak   |
| 3   | 7323.00     | 36.28              | 12.54           | 41.84          | 35.57           | 55.09                   | 74.00           | 18.91       | Peak   |

Remarks: 1. Emission Level= Antenna Factor + Cable Loss + Reading - Amp Factor  
 2. The emission levels that are 20dB below the official limit are not reported.

| Frequency ( MHz ) | Original AV level ( dBuv/m ) | Duty cycle factor (dB) | Final AV level (dBuv/m) | Limit(dBuv/m) | Conclusion |
|-------------------|------------------------------|------------------------|-------------------------|---------------|------------|
| 7323.00           | 55.09                        | -30.722                | 24.368                  | 54            | Pass       |

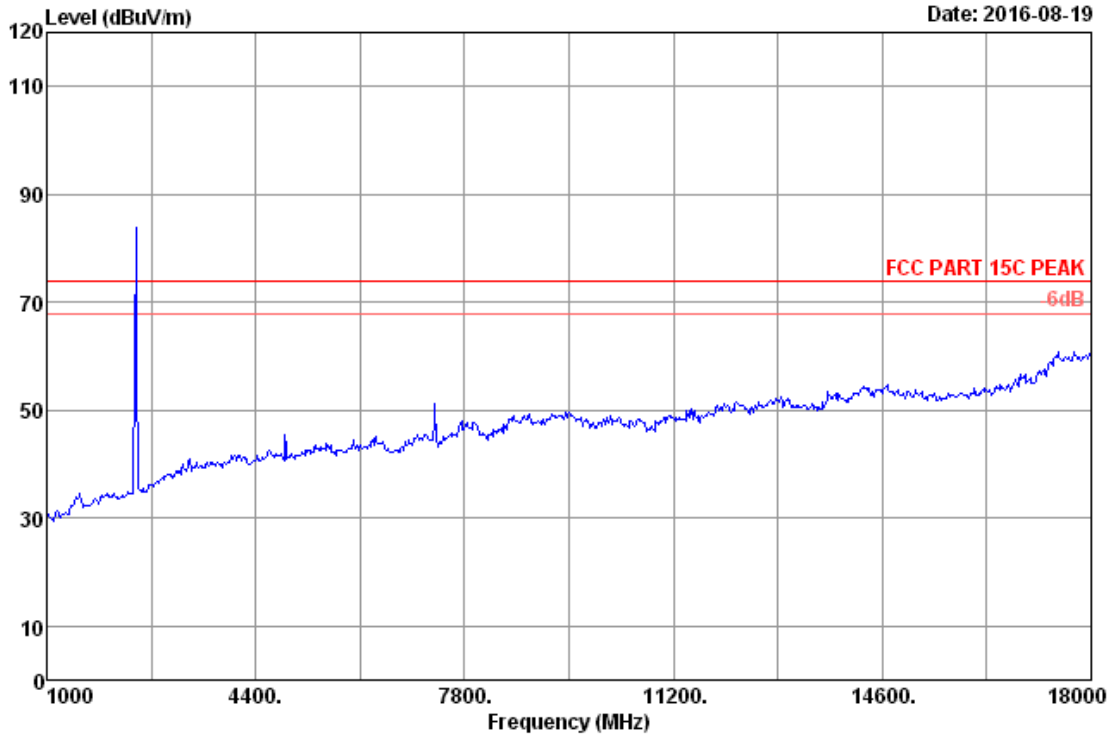

|              |                          |           |                |
|--------------|--------------------------|-----------|----------------|
| Site no.     | : RF Chamber             | Data no.  | : 9            |
| Dis. / Ant.  | : 3m 2015 3115-4877      | Ant. pol. | : HORIZONTAL   |
| Limit        | : FCC PART 15C PEAK      | Pre       | : 101.2kPa     |
| Env. / Ins.  | : 22.6*C/51.2%           | Engineer  | : Donjon_Huang |
| EUT          | : Mobile wall mount unit |           |                |
| Power rating | : DC 12V                 |           |                |
| Test Mode    | : GFSK 2441MHz Tx Mode   |           |                |
| M/N          | : JWM1A                  |           |                |

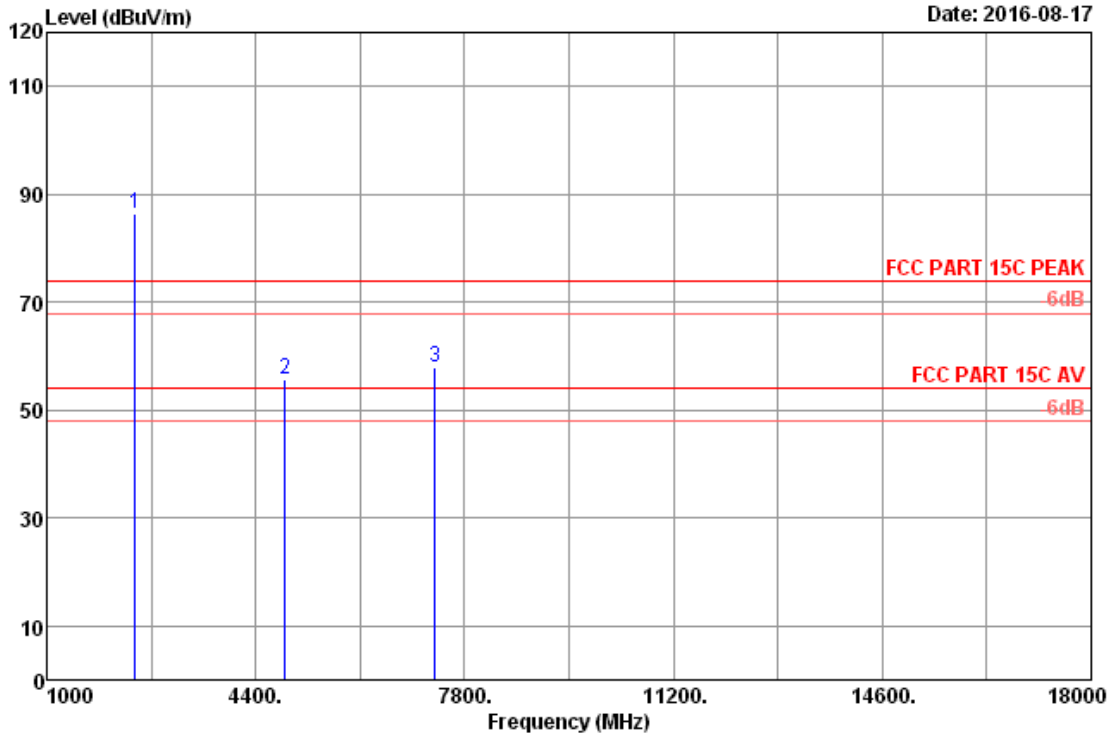

Site no. : RF Chamber                      Data no. : 10  
 Dis. / Ant. : 3m 2015 3115-4877            Ant. pol. : HORIZONTAL  
 Limit : FCC PART 15C PEAK                Pre : 101.2kPa  
 Env. / Ins. : 22.6\*C/51.2%                Engineer : Donjon\_Huang  
 EUT : Mobile wall mount unit  
 Power rating : DC 12V  
 Test Mode : GFSK 2441MHz Tx Mode  
 M/N : JWM1A

| No. | Freq. (MHz) | Ant. Factor (dB/m) | Cable Loss (dB) | Reading (dBuV) | AMP factor (dB) | Emission Level (dBuV/m) | Limits (dBuV/m) | Margin (dB) | Remark |
|-----|-------------|--------------------|-----------------|----------------|-----------------|-------------------------|-----------------|-------------|--------|
| 1   | 2441.00     | 28.33              | 8.38            | 86.17          | 36.38           | 86.50                   | 74.00           | -12.50      | Peak   |
| 2   | 4882.00     | 33.26              | 11.80           | 46.22          | 35.69           | 55.59                   | 74.00           | 18.41       | Peak   |
| 3   | 7323.00     | 36.28              | 12.54           | 44.82          | 35.57           | 58.07                   | 74.00           | 15.93       | Peak   |

Remarks: 1. Emission Level= Antenna Factor + Cable Loss + Reading - Amp Factor  
 2. The emission levels that are 20dB below the official limit are not reported.

| Frequency ( MHz ) | Original AV level ( dBuv/m ) | Duty cycle factor (dB) | Final AV level (dBuv/m) | Limit(dBuv/m) | Conclusion |
|-------------------|------------------------------|------------------------|-------------------------|---------------|------------|
| 4882.00           | 55.59                        | -30.722                | 24.868                  | 54            | Pass       |
| 7323.00           | 58.07                        | -30.722                | 27.348                  | 54            | Pass       |

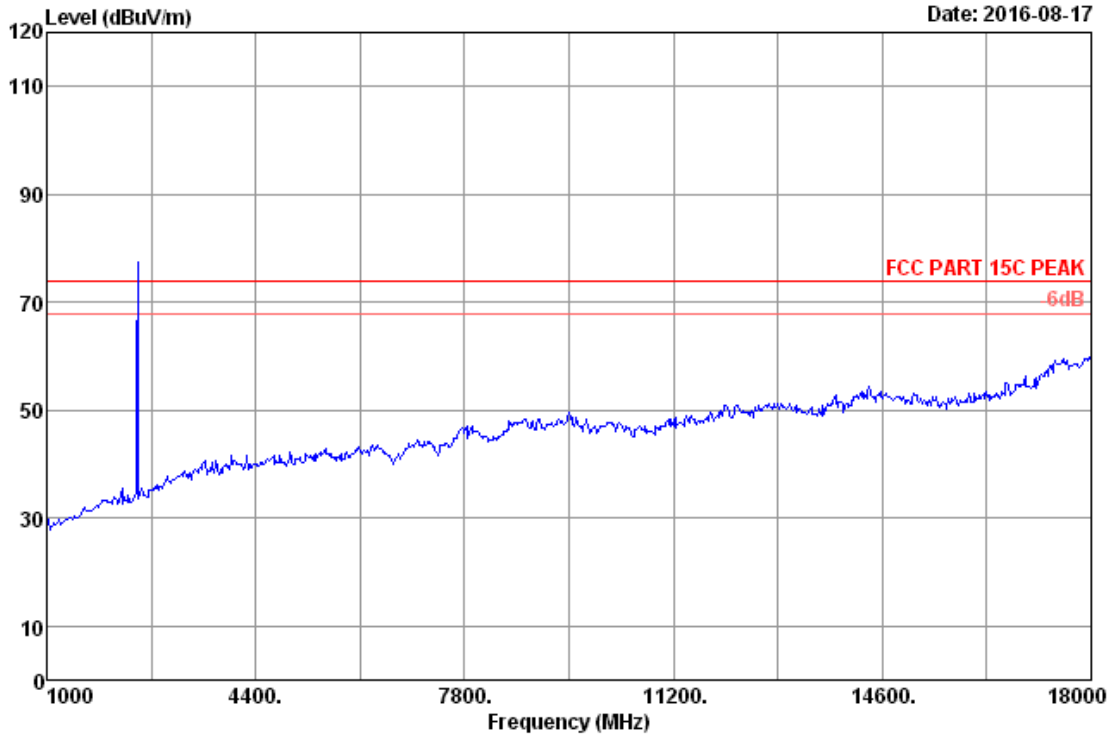

|                                  |                         |
|----------------------------------|-------------------------|
| Site no. : RF Chamber            | Data no. : 11           |
| Dis. / Ant. : 3m 2015 3115-4877  | Ant. pol. : VERTICAL    |
| Limit : FCC PART 15C PEAK        | Pre : 101.2kPa          |
| Env. / Ins. : 22.6*C/51.2%       | Engineer : Donjon_Huang |
| EUT : Mobile wall mount unit     |                         |
| Power rating : DC 12V            |                         |
| Test Mode : GFSK 2480MHz Tx Mode |                         |
| M/N : JWM1A                      |                         |



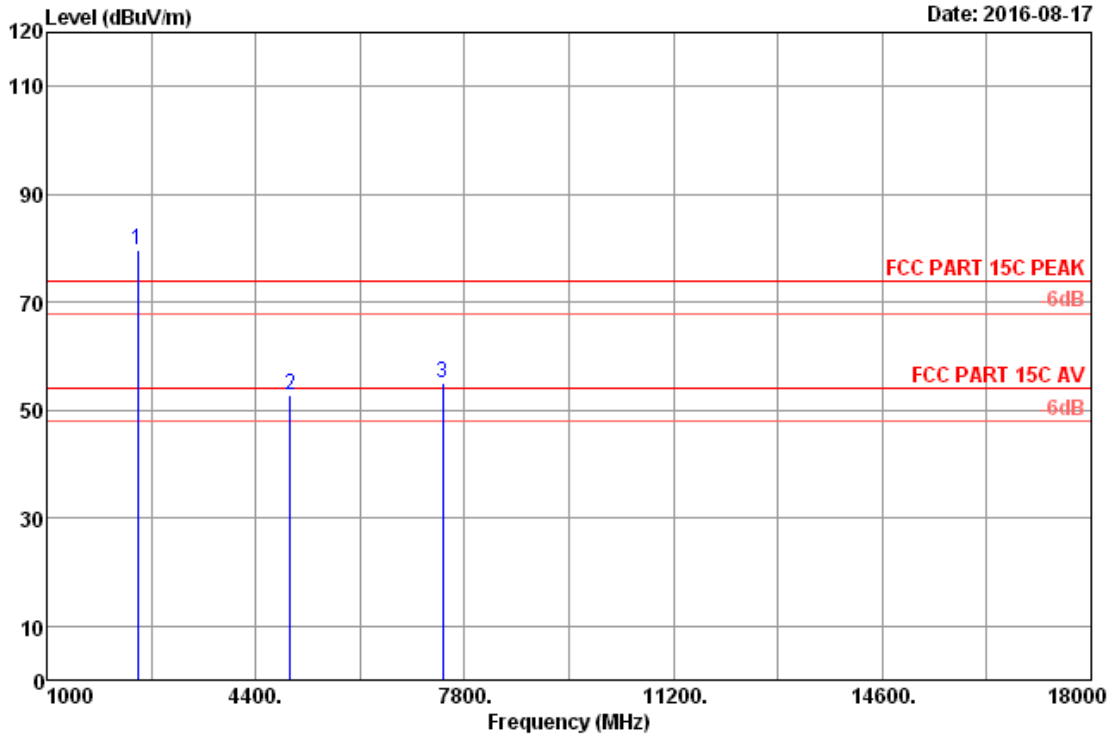

Site no. : RF Chamber  
 Dis. / Ant. : 3m 2015 3115-4877  
 Limit : FCC PART 15C PEAK  
 Env. / Ins. : 22.6°C/51.2%  
 EUT : Mobile wall mount unit  
 Power rating : DC 12V  
 Test Mode : GFSK 2480MHz Tx Mode  
 M/N : JWM1A

Data no. : 12  
 Ant. pol. : VERTICAL  
 Pre : 101.2kPa  
 Engineer : Donjon\_Huang

| No. | Freq. (MHz) | Ant. Factor (dB/m) | Cable Loss (dB) | Reading (dBuV) | AMP factor (dB) | Emission Level (dBuV/m) | Limits (dBuV/m) | Margin (dB) | Remark |
|-----|-------------|--------------------|-----------------|----------------|-----------------|-------------------------|-----------------|-------------|--------|
| 1   | 2480.00     | 28.38              | 8.42            | 79.24          | 36.38           | 79.66                   | 74.00           | -5.66       | Peak   |
| 2   | 4960.00     | 33.42              | 11.85           | 43.28          | 35.71           | 52.84                   | 74.00           | 21.16       | Peak   |
| 3   | 7440.00     | 36.56              | 12.64           | 41.49          | 35.59           | 55.10                   | 74.00           | 18.90       | Peak   |

Remarks: 1. Emission Level= Antenna Factor + Cable Loss + Reading - Amp Factor  
 2. The emission levels that are 20dB below the official limit are not reported.

| Frequency ( MHz ) | Original AV level ( dBuV/m ) | Duty cycle factor (dB) | Final AV level (dBuV/m) | Limit(dBuV/m) | Conclusion |
|-------------------|------------------------------|------------------------|-------------------------|---------------|------------|
| 7440.00           | 55.10                        | -30.722                | 24.378                  | 54            | Pass       |

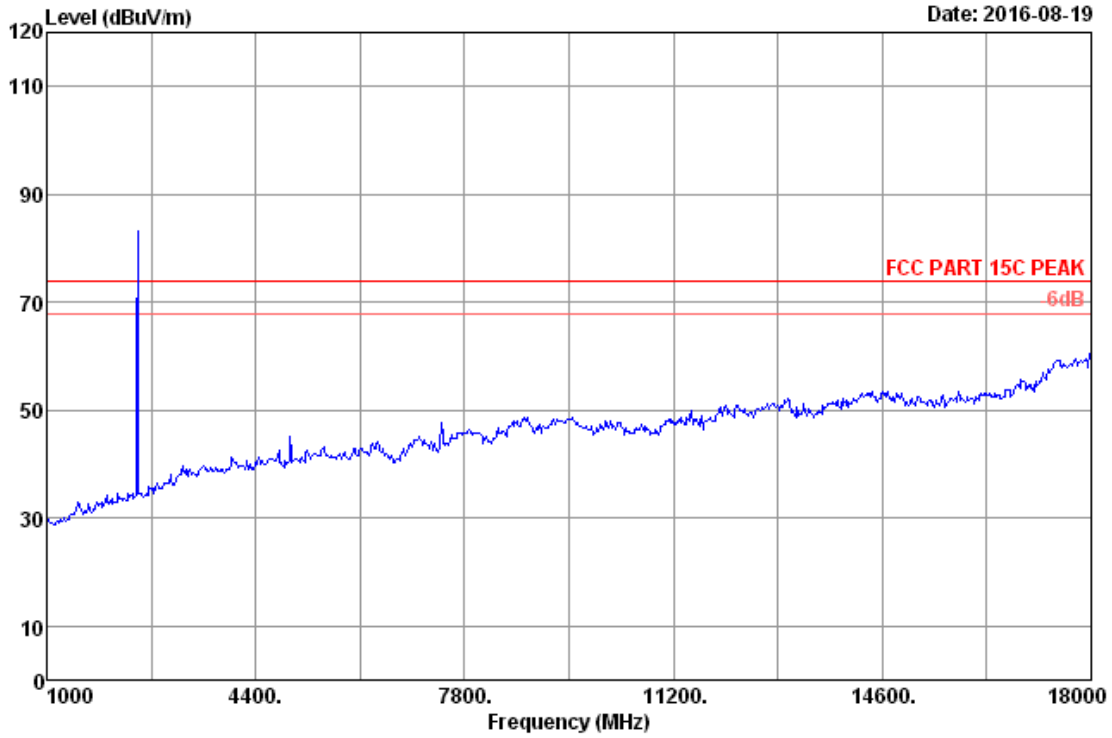

|                                  |                         |
|----------------------------------|-------------------------|
| Site no. : RF Chamber            | Data no. : 13           |
| Dis. / Ant. : 3m 2015 3115-4877  | Ant. pol. : HORIZONTAL  |
| Limit : FCC PART 15C PEAK        | Pre : 101.2kPa          |
| Env. / Ins. : 22.6*C/51.2%       | Engineer : Donjon_Huang |
| EUT : Mobile wall mount unit     |                         |
| Power rating : DC 12V            |                         |
| Test Mode : GFSK 2480MHz Tx Mode |                         |
| M/N : JWM1A                      |                         |

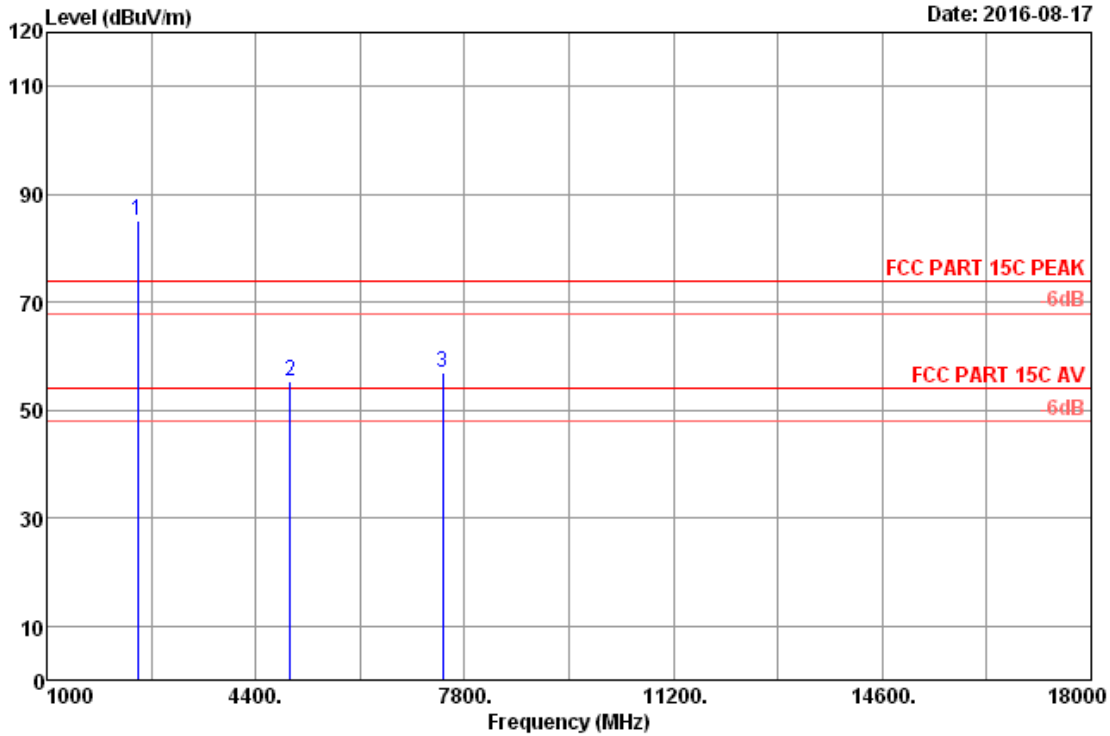

Site no. : RF Chamber Data no. : 14  
 Dis. / Ant. : 3m 2015 3115-4877 Ant. pol. : HORIZONTAL  
 Limit : FCC PART 15C PEAK Pre : 101.2kPa  
 Env. / Ins. : 22.6°C/51.2% Engineer : Donjon\_Huang  
 EUT : Mobile wall mount unit  
 Power rating : DC 12V  
 Test Mode : GFSK 2480MHz Tx Mode  
 M/N : JWM1A

| No. | Freq. (MHz) | Ant. Factor (dB/m) | Cable Loss (dB) | Reading (dBuV) | AMP factor (dB) | Emission Level (dBuV/m) | Limits (dBuV/m) | Margin (dB) | Remark |
|-----|-------------|--------------------|-----------------|----------------|-----------------|-------------------------|-----------------|-------------|--------|
| 1   | 2480.00     | 28.38              | 8.42            | 84.84          | 36.38           | 85.26                   | 74.00           | -11.26      | Peak   |
| 2   | 4960.00     | 33.42              | 11.85           | 45.73          | 35.71           | 55.29                   | 74.00           | 18.71       | Peak   |
| 3   | 7440.00     | 36.56              | 12.64           | 43.34          | 35.59           | 56.95                   | 74.00           | 17.05       | Peak   |

Remarks: 1. Emission Level= Antenna Factor + Cable Loss + Reading - Amp Factor  
 2. The emission levels that are 20dB below the official limit are not reported.

| Frequency ( MHz ) | Original AV level ( dBuv/m ) | Duty cycle factor (dB) | Final AV level (dBuv/m) | Limit(dBuv/m) | Conclusion |
|-------------------|------------------------------|------------------------|-------------------------|---------------|------------|
| 4960.00           | 55.29                        | -30.722                | 24.568                  | 54            | Pass       |
| 7440.00           | 56.95                        | -30.722                | 26.228                  | 54            | Pass       |

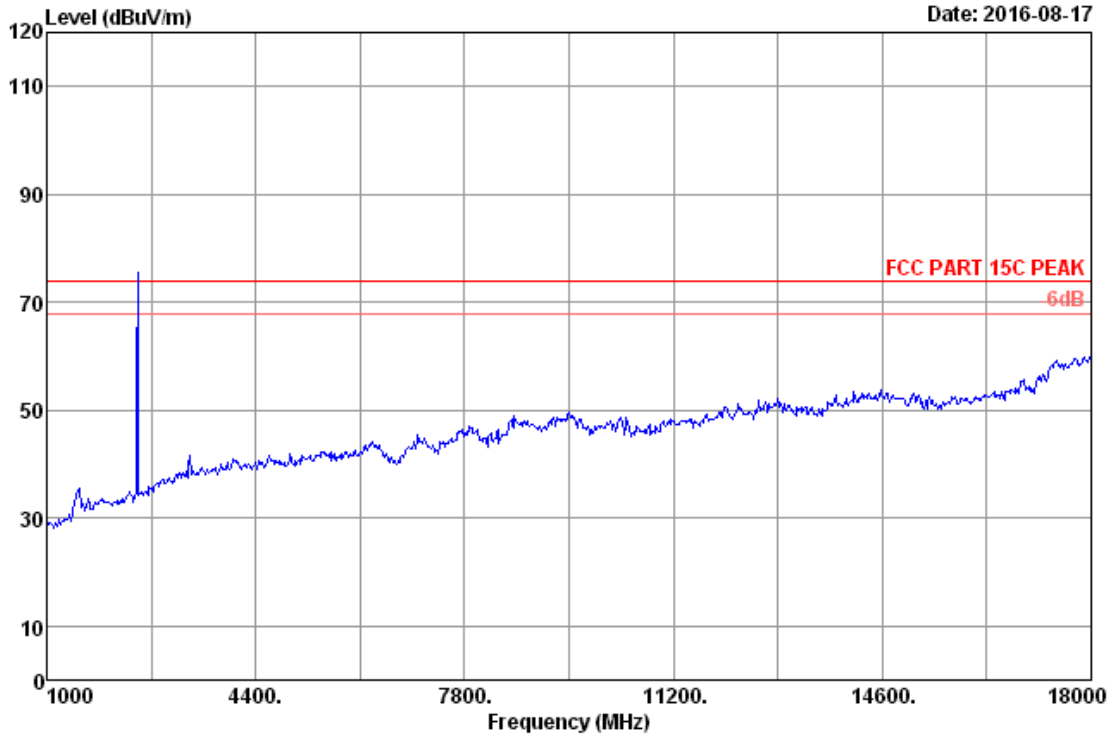

|                                    |                         |
|------------------------------------|-------------------------|
| Site no. : RF Chamber              | Data no. : 19           |
| Dis. / Ant. : 3m 2015 3115-4877    | Ant. pol. : HORIZONTAL  |
| Limit : FCC PART 15C PEAK          | Pre : 101.2kPa          |
| Env. / Ins. : 22.6*C/51.2%         | Engineer : Donjon_Huang |
| EUT : Mobile wall mount unit       |                         |
| Power rating : DC 12V              |                         |
| Test Mode : 8-DPSK 2480MHz Tx Mode |                         |
| M/N : JWM1A                        |                         |

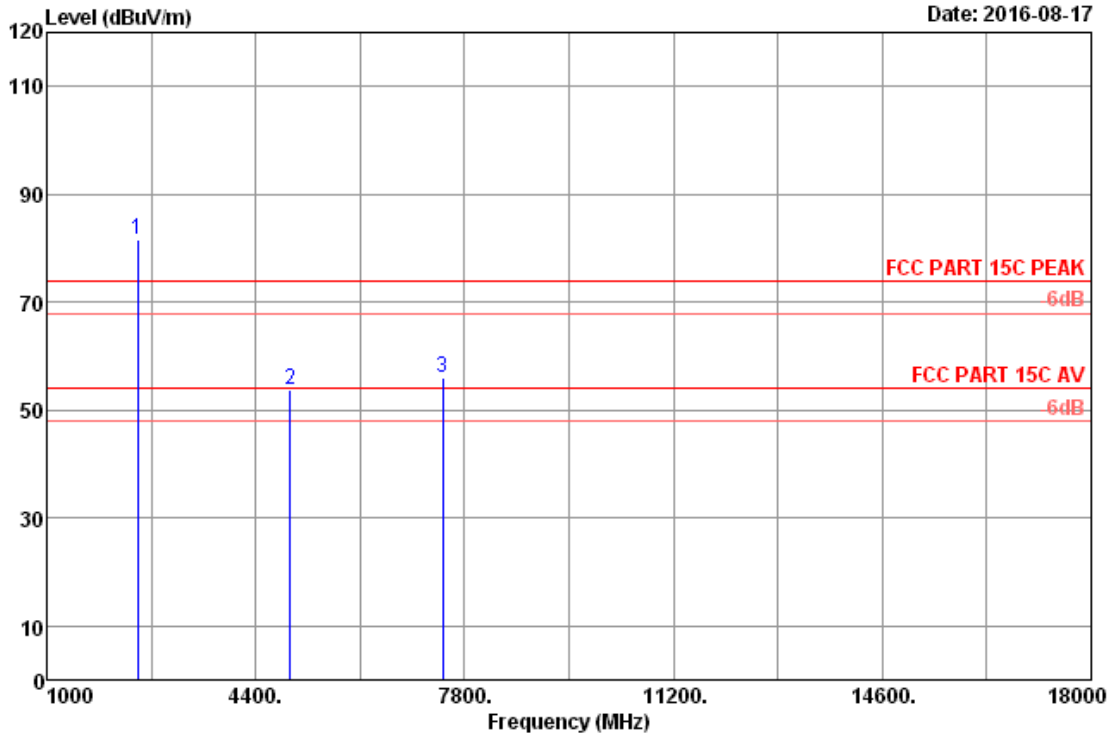

Site no. : RF Chamber Data no. : 20  
 Dis. / Ant. : 3m 2015 3115-4877 Ant. pol. : HORIZONTAL  
 Limit : FCC PART 15C PEAK Pre : 101.2kPa  
 Env. / Ins. : 22.6°C/51.2% Engineer : Donjon\_Huang  
 EUT : Mobile wall mount unit  
 Power rating : DC 12V  
 Test Mode : 8-DPSK 2480MHz Tx Mode  
 M/N : JWM1A

| No. | Freq. (MHz) | Ant. Factor (dB/m) | Cable Loss (dB) | Reading (dBuV) | AMP factor (dB) | Emission Level (dBuV/m) | Limits (dBuV/m) | Margin (dB) | Remark |
|-----|-------------|--------------------|-----------------|----------------|-----------------|-------------------------|-----------------|-------------|--------|
| 1   | 2480.00     | 28.38              | 8.42            | 81.06          | 36.38           | 81.48                   | 74.00           | -7.48       | Peak   |
| 2   | 4960.00     | 33.42              | 11.85           | 44.33          | 35.71           | 53.89                   | 74.00           | 20.11       | Peak   |
| 3   | 7440.00     | 36.56              | 12.64           | 42.32          | 35.59           | 55.93                   | 74.00           | 18.07       | Peak   |

Remarks: 1. Emission Level= Antenna Factor + Cable Loss + Reading - Amp Factor  
 2. The emission levels that are 20dB below the official limit are not reported.

| Frequency ( MHz ) | Original AV level ( dBuV/m ) | Duty cycle factor (dB) | Final AV level (dBuV/m) | Limit(dBuv/m) | Conclusion |
|-------------------|------------------------------|------------------------|-------------------------|---------------|------------|
| 7440.00           | 55.93                        | -30.722                | 25.208                  | 54            | Pass       |

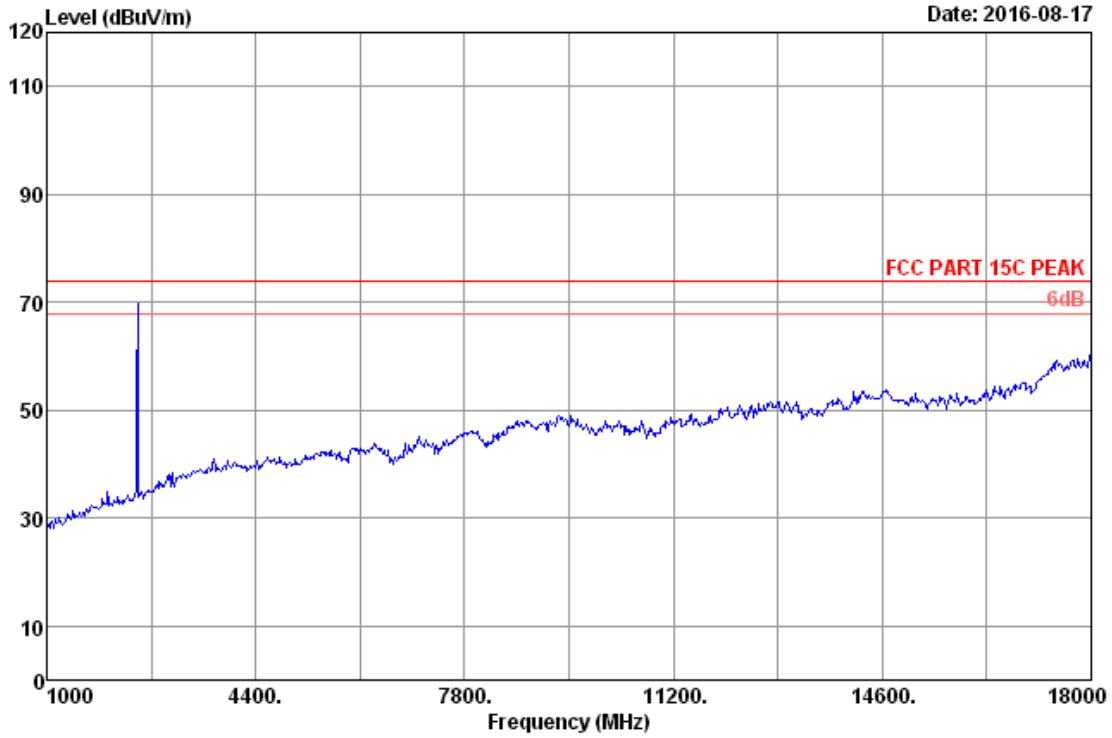

|                                    |                         |
|------------------------------------|-------------------------|
| Site no. : RF Chamber              | Data no. : 21           |
| Dis. / Ant. : 3m 2015 3115-4877    | Ant. pol. : VERTICAL    |
| Limit : FCC PART 15C PEAK          | Pre : 101.2kPa          |
| Env. / Ins. : 22.6*C/51.2%         | Engineer : Donjon_Huang |
| EUT : Mobile wall mount unit       |                         |
| Power rating : DC 12V              |                         |
| Test Mode : 8-DPSK 2480MHz Tx Mode |                         |
| M/N : JWM1A                        |                         |

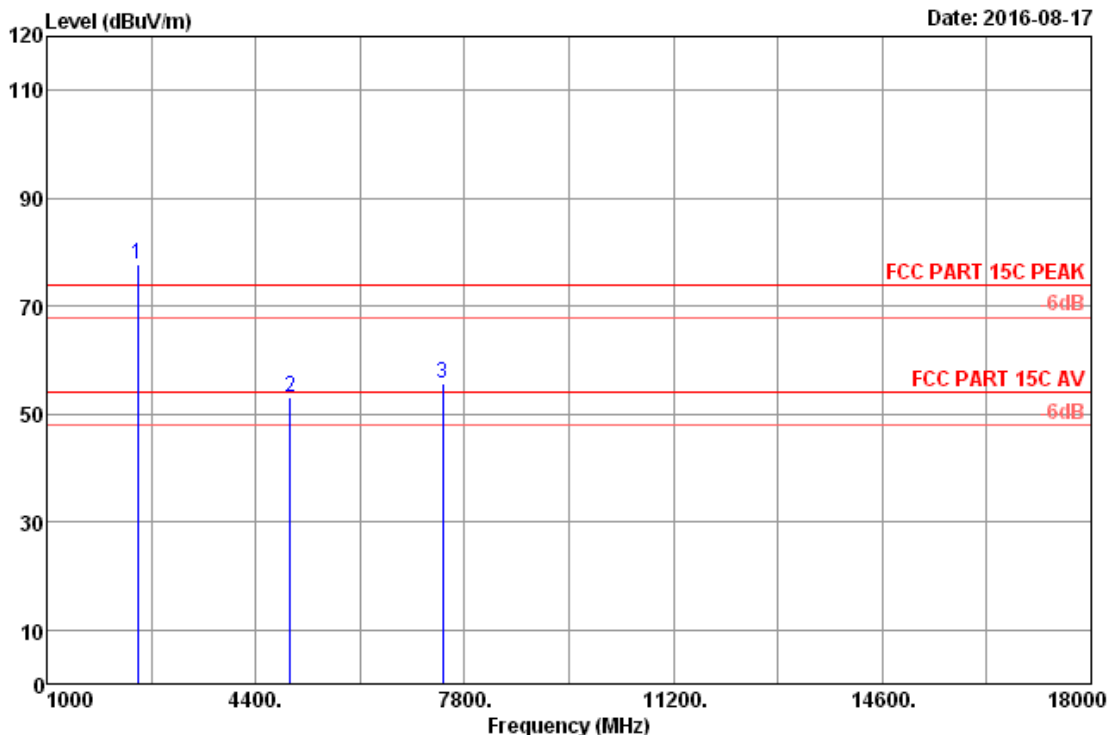

```

Site no.      : RF Chamber
Dis. / Ant.   : 3m  2015 3115-4877
Limit         : FCC PART 15C PEAK
Env. / Ins.   : 22.6*C/51.2%
EUT           : Mobile wall mount unit
Power rating  : DC 12V
Test Mode     : 8-DPSK 2480MHz Tx Mode
M/N          : JWM1A

Data no.      : 22
Ant. pol.     : VERTICAL
Pre           : 101.2kPa
Engineer      : Donjon_Huang
  
```

| No. | Freq. (MHz) | Ant. Factor (dB/m) | Cable Loss (dB) | Reading (dBuV) | AMP factor (dB) | Emission Level (dBuV/m) | Limits (dBuV/m) | Margin (dB) | Remark |
|-----|-------------|--------------------|-----------------|----------------|-----------------|-------------------------|-----------------|-------------|--------|
| 1   | 2480.00     | 28.38              | 8.42            | 77.45          | 36.38           | 77.87                   | 74.00           | -3.87       | Peak   |
| 2   | 4960.00     | 33.42              | 11.85           | 43.70          | 35.71           | 53.26                   | 74.00           | 20.74       | Peak   |
| 3   | 7440.00     | 36.56              | 12.64           | 41.93          | 35.59           | 55.54                   | 74.00           | 18.46       | Peak   |

Remarks: 1. Emission Level= Antenna Factor + Cable Loss + Reading - Amp Factor  
 2. The emission levels that are 20dB below the official limit are not reported.

| Frequency ( MHz ) | Original AV level ( dBuV/m ) | Duty cycle factor (dB) | Final AV level (dBuV/m) | Limit(dBuv/m) | Conclusion |
|-------------------|------------------------------|------------------------|-------------------------|---------------|------------|
| 7440.00           | 55.54                        | -30.722                | 24.818                  | 54            | Pass       |

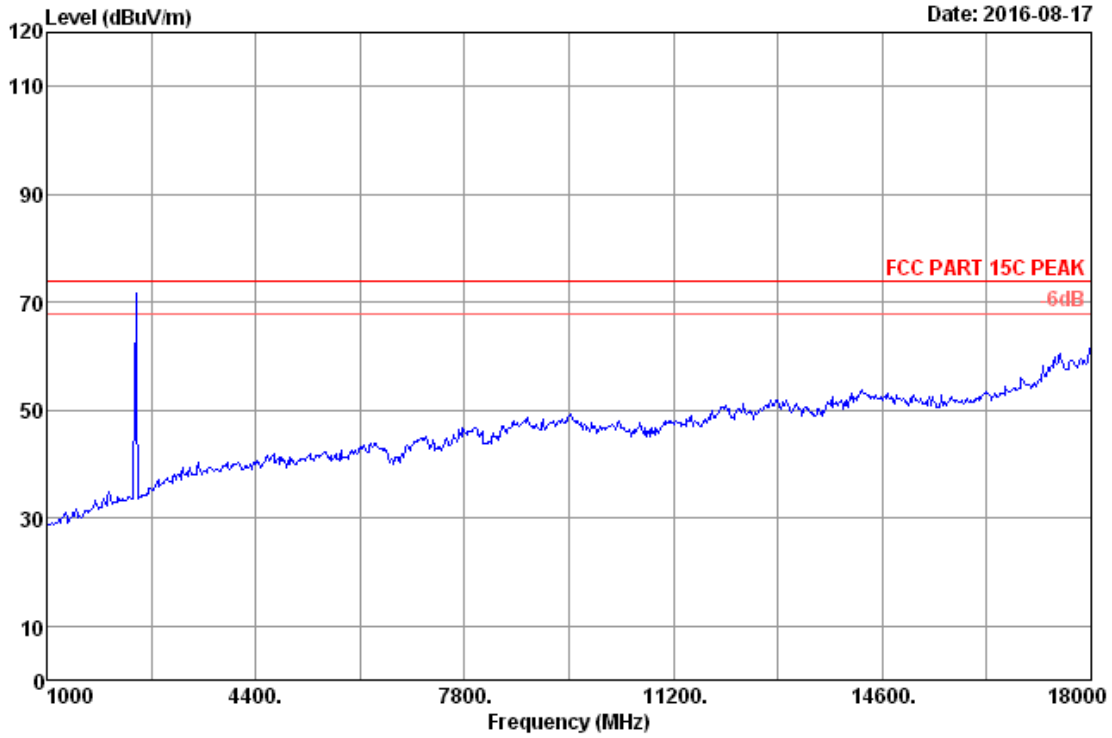

|                                    |                         |
|------------------------------------|-------------------------|
| Site no. : RF Chamber              | Data no. : 23           |
| Dis. / Ant. : 3m 2015 3115-4877    | Ant. pol. : VERTICAL    |
| Limit : FCC PART 15C PEAK          | Pre : 101.2kPa          |
| Env. / Ins. : 22.6*C/51.2%         | Engineer : Donjon_Huang |
| EUT : Mobile wall mount unit       |                         |
| Power rating : DC 12V              |                         |
| Test Mode : 8-DPSK 2441MHz Tx Mode |                         |
| M/N : JWM1A                        |                         |



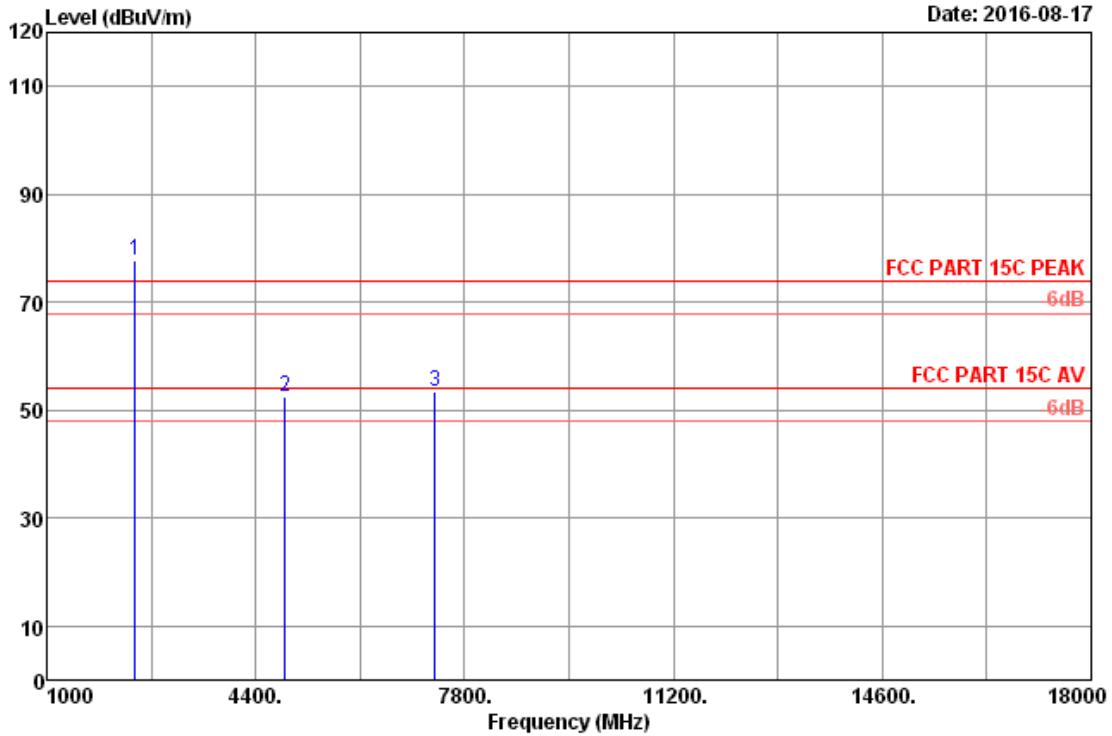

Site no. : RF Chamber Data no. : 24  
 Dis. / Ant. : 3m 2015 3115-4877 Ant. pol. : VERTICAL  
 Limit : FCC PART 15C PEAK Pre : 101.2kPa  
 Env. / Ins. : 22.6°C/51.2% Engineer : Donjon\_Huang  
 EUT : Mobile wall mount unit  
 Power rating : DC 12V  
 Test Mode : 8-DPSK 2441MHz Tx Mode  
 M/N : JWM1A

| No. | Freq. (MHz) | Ant. Factor (dB/m) | Cable Loss (dB) | Reading (dBuV) | AMP factor (dB) | Emission Level (dBuV/m) | Limits (dBuV/m) | Margin (dB) | Remark |
|-----|-------------|--------------------|-----------------|----------------|-----------------|-------------------------|-----------------|-------------|--------|
| 1   | 2441.00     | 28.33              | 8.38            | 77.50          | 36.38           | 77.83                   | 74.00           | -3.83       | Peak   |
| 2   | 4882.00     | 33.26              | 11.80           | 43.22          | 35.69           | 52.59                   | 74.00           | 21.41       | Peak   |
| 3   | 7323.00     | 36.28              | 12.54           | 40.31          | 35.57           | 53.56                   | 74.00           | 20.44       | Peak   |

Remarks: 1. Emission Level= Antenna Factor + Cable Loss + Reading - Amp Factor  
 2. The emission levels that are 20dB below the official limit are not reported.

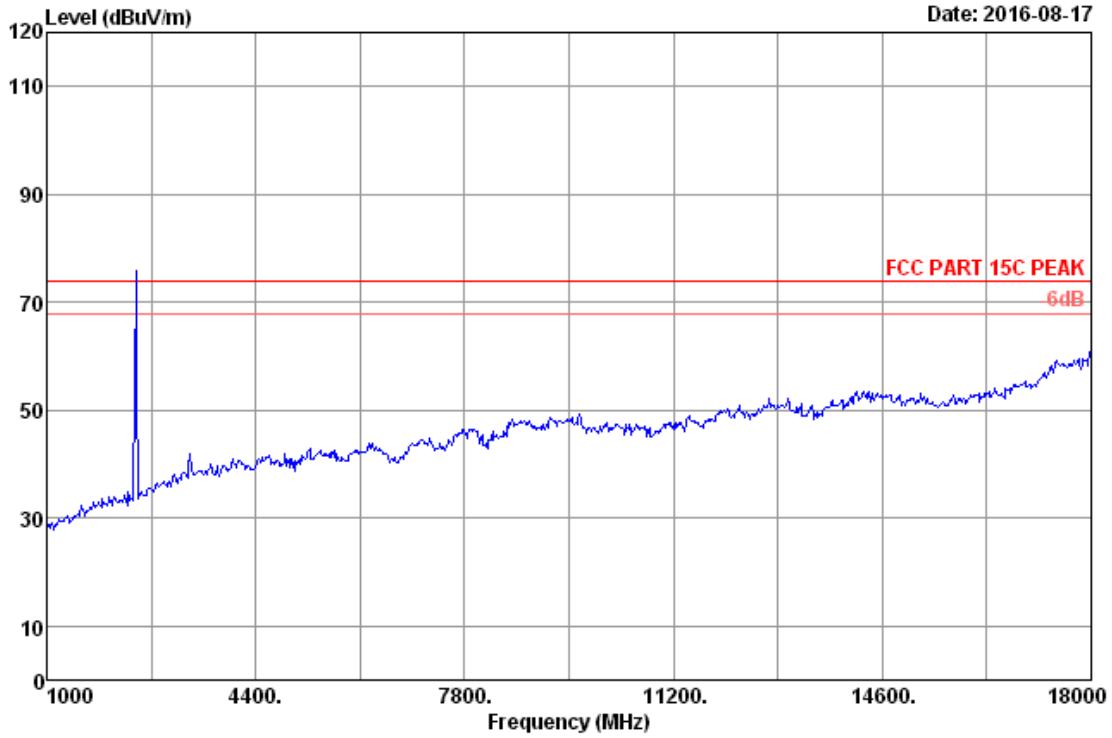

|                                    |                         |
|------------------------------------|-------------------------|
| Site no. : RF Chamber              | Data no. : 25           |
| Dis. / Ant. : 3m 2015 3115-4877    | Ant. pol. : HORIZONTAL  |
| Limit : FCC PART 15C PEAK          | Pre : 101.2kPa          |
| Env. / Ins. : 22.6*C/51.2%         | Engineer : Donjon_Huang |
| EUT : Mobile wall mount unit       |                         |
| Power rating : DC 12V              |                         |
| Test Mode : 8-DPSK 2441MHz Tx Mode |                         |
| M/N : JWM1A                        |                         |

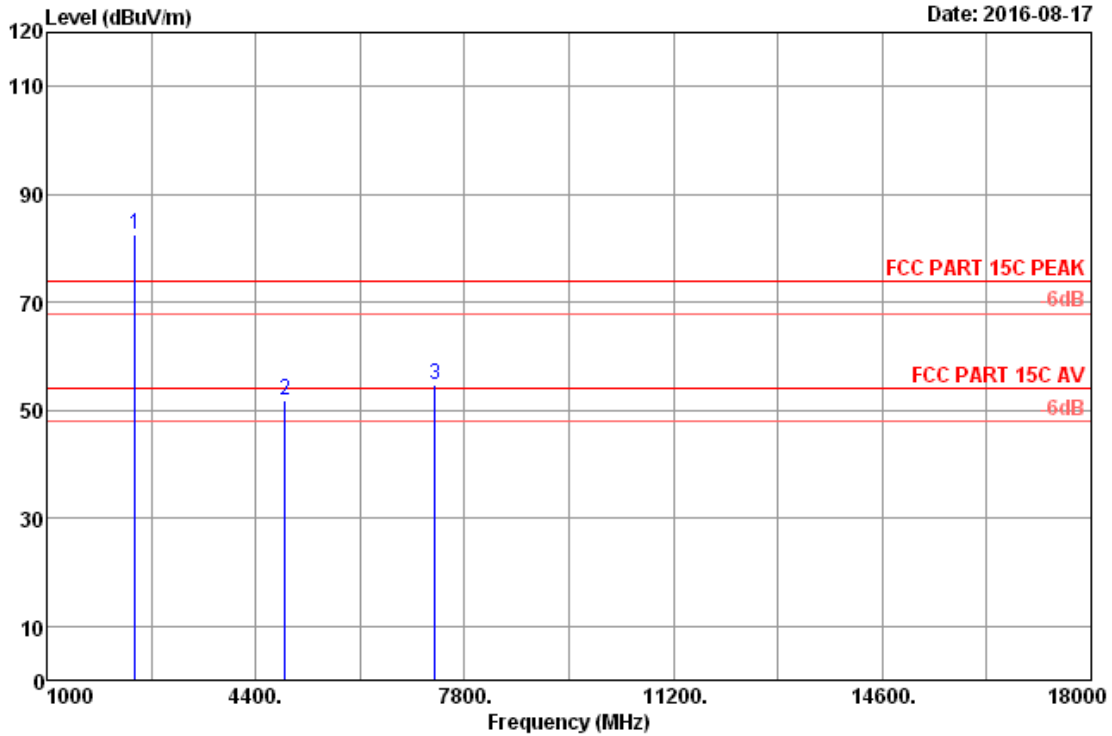

Site no. : RF Chamber Data no. : 26  
 Dis. / Ant. : 3m 2015 3115-4877 Ant. pol. : HORIZONTAL  
 Limit : FCC PART 15C PEAK Pre : 101.2kPa  
 Env. / Ins. : 22.6°C/51.2% Engineer : Donjon\_Huang  
 EUT : Mobile wall mount unit  
 Power rating : DC 12V  
 Test Mode : 8-DPSK 2441MHz Tx Mode  
 M/N : JWM1A

| No. | Freq. (MHz) | Ant. Factor (dB/m) | Cable Loss (dB) | Reading (dBuV) | AMP factor (dB) | Emission Level (dBuV/m) | Limits (dBuV/m) | Margin (dB) | Remark |
|-----|-------------|--------------------|-----------------|----------------|-----------------|-------------------------|-----------------|-------------|--------|
| 1   | 2441.00     | 28.33              | 8.38            | 82.27          | 36.38           | 82.60                   | 74.00           | -8.60       | Peak   |
| 2   | 4882.00     | 33.26              | 11.80           | 42.59          | 35.69           | 51.96                   | 74.00           | 22.04       | Peak   |
| 3   | 7323.00     | 36.28              | 12.54           | 41.37          | 35.57           | 54.62                   | 74.00           | 19.38       | Peak   |

Remarks: 1. Emission Level= Antenna Factor + Cable Loss + Reading - Amp Factor  
 2. The emission levels that are 20dB below the official limit are not reported.

| Frequency ( MHz ) | Original AV level ( dBuV/m ) | Duty cycle factor (dB) | Final AV level (dBuV/m) | Limit(dBuv/m) | Conclusion |
|-------------------|------------------------------|------------------------|-------------------------|---------------|------------|
| 7323.00           | 54.62                        | -30.722                | 23.898                  | 54            | Pass       |

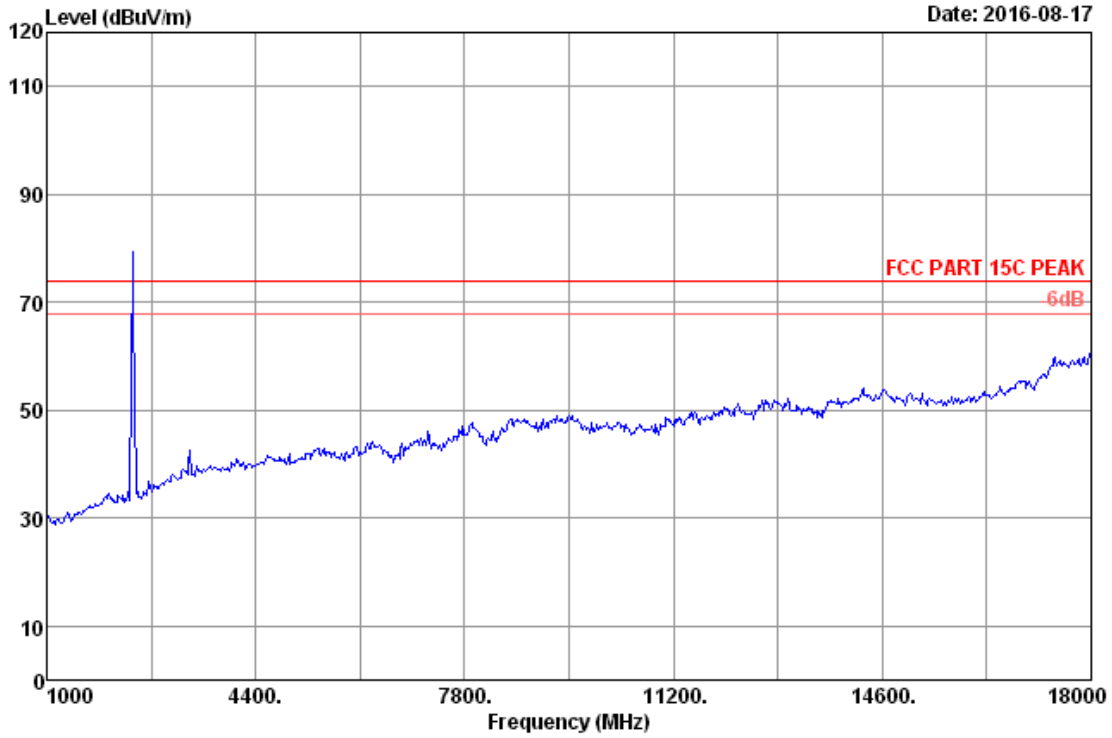

|                                    |                         |
|------------------------------------|-------------------------|
| Site no. : RF Chamber              | Data no. : 27           |
| Dis. / Ant. : 3m 2015 3115-4877    | Ant. pol. : HORIZONTAL  |
| Limit : FCC PART 15C PEAK          | Pre : 101.2kPa          |
| Env. / Ins. : 22.6*C/51.2%         | Engineer : Donjon_Huang |
| EUT : Mobile wall mount unit       |                         |
| Power rating : DC 12V              |                         |
| Test Mode : 8-DPSK 2402MHz Tx Mode |                         |
| M/N : JWM1A                        |                         |

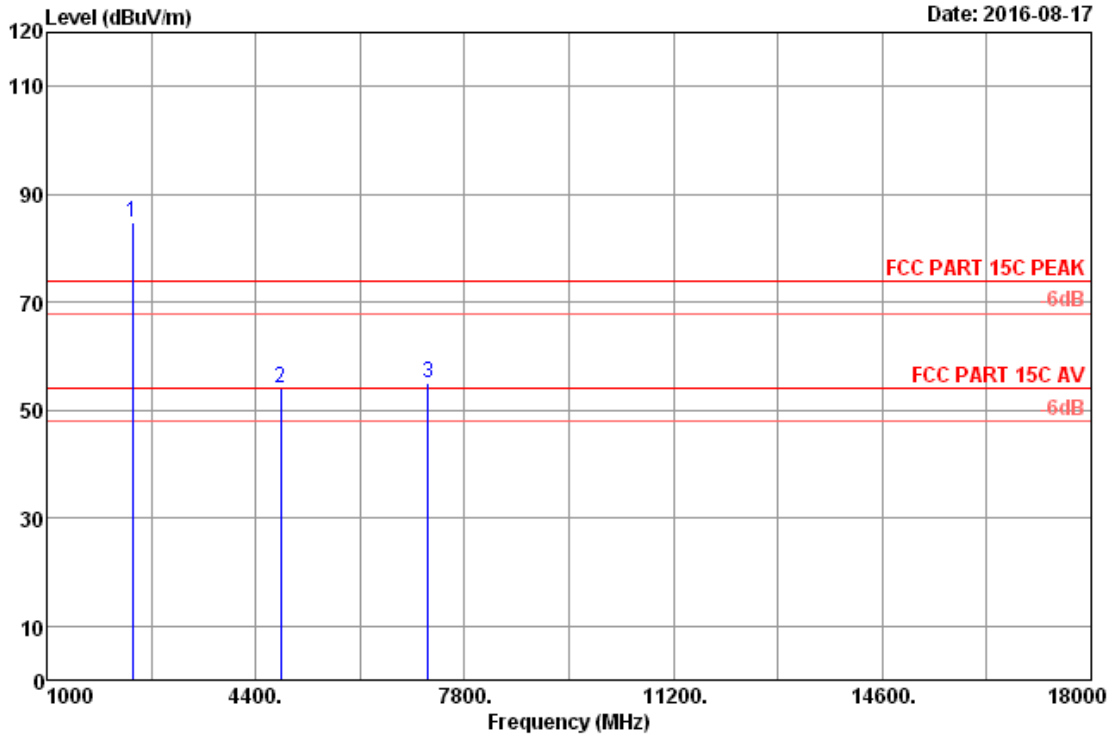

Date: 2016-08-17

Site no. : RF Chamber Data no. : 28  
 Dis. / Ant. : 3m 2015 3115-4877 Ant. pol. : HORIZONTAL  
 Limit : FCC PART 15C PEAK Pre : 101.2kPa  
 Env. / Ins. : 22.6°C/51.2% Engineer : Donjon\_Huang  
 EUT : Mobile wall mount unit  
 Power rating : DC 12V  
 Test Mode : 8-DPSK 2402MHz Tx Mode  
 M/N : JWM1A

| No. | Freq. (MHz) | Ant. Factor (dB/m) | Cable Loss (dB) | Reading (dBuV) | AMP factor (dB) | Emission Level (dBuV/m) | Limits (dBuV/m) | Margin (dB) | Remark |
|-----|-------------|--------------------|-----------------|----------------|-----------------|-------------------------|-----------------|-------------|--------|
| 1   | 2402.00     | 28.28              | 8.34            | 84.60          | 36.39           | 84.83                   | 74.00           | -10.83      | Peak   |
| 2   | 4804.00     | 33.11              | 11.75           | 44.85          | 35.67           | 54.04                   | 74.00           | 19.96       | Peak   |
| 3   | 7206.00     | 35.99              | 12.44           | 42.11          | 35.55           | 54.99                   | 74.00           | 19.01       | Peak   |

Remarks: 1. Emission Level= Antenna Factor + Cable Loss + Reading - Amp Factor  
 2. The emission levels that are 20dB below the official limit are not reported.

| Frequency ( MHz ) | Original AV level ( dBuv/m ) | Duty cycle factor (dB) | Final AV level (dBuv/m) | Limit(dBuv/m) | Conclusion |
|-------------------|------------------------------|------------------------|-------------------------|---------------|------------|
| 4804.00           | 54.04                        | -30.722                | 23.318                  | 54            | Pass       |
| 7206.00           | 54.99                        | -30.722                | 24.268                  | 54            | Pass       |

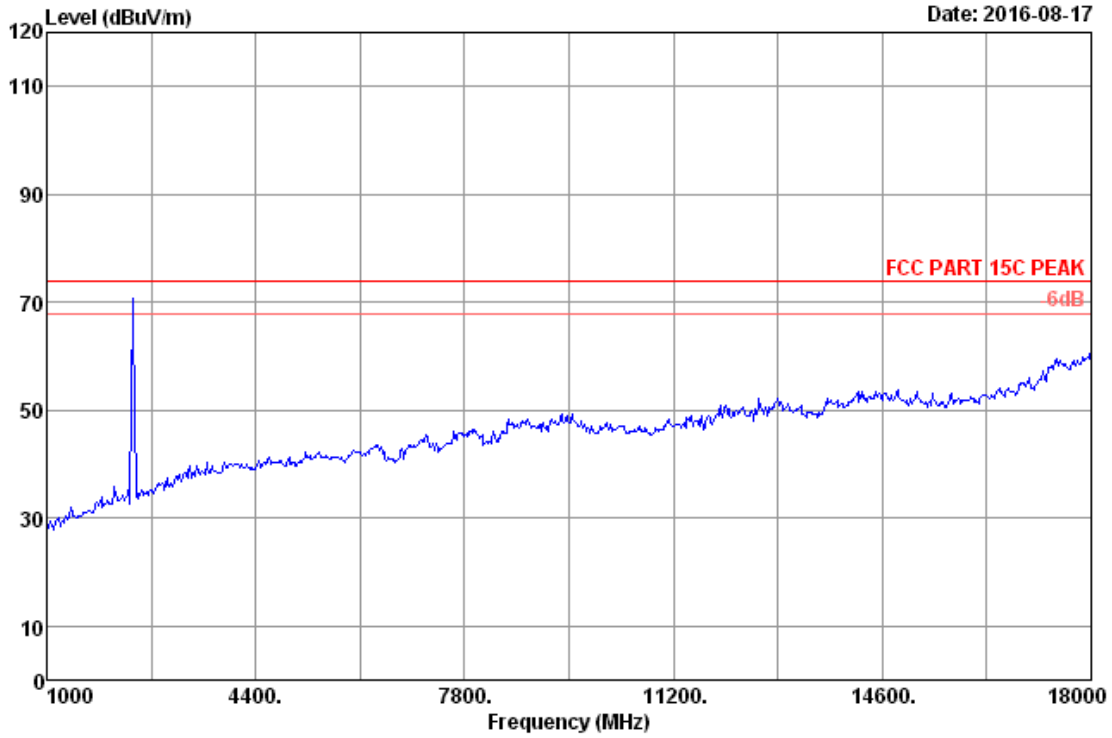

|                                    |                         |
|------------------------------------|-------------------------|
| Site no. : RF Chamber              | Data no. : 29           |
| Dis. / Ant. : 3m 2015 3115-4877    | Ant. pol. : VERTICAL    |
| Limit : FCC PART 15C PEAK          | Pre : 101.2kPa          |
| Env. / Ins. : 22.6*C/51.2%         | Engineer : Donjon_Huang |
| EUT : Mobile wall mount unit       |                         |
| Power rating : DC 12V              |                         |
| Test Mode : 8-DPSK 2402MHz Tx Mode |                         |
| M/N : JWM1A                        |                         |

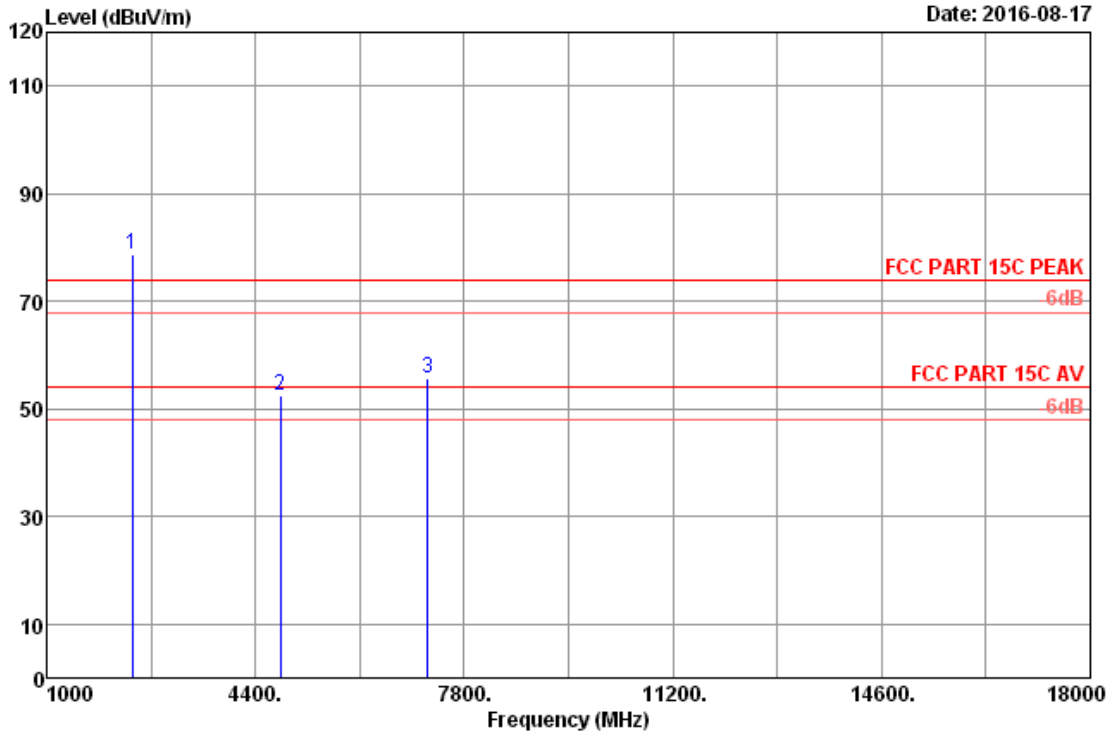

Date: 2016-08-17

Site no. : RF Chamber  
 Dis. / Ant. : 3m 2015 3115-4877  
 Limit : FCC PART 15C PEAK  
 Env. / Ins. : 22.6°C/51.2%  
 EUT : Mobile wall mount unit  
 Power rating : DC 12V  
 Test Mode : 8-DPSK 2402MHz Tx Mode  
 M/N : JWM1A

Data no. : 30  
 Ant. pol. : VERTICAL  
 Pre : 101.2kPa  
 Engineer : Donjon\_Huang

| No. | Freq. (MHz) | Ant. Factor (dB/m) | Cable Loss (dB) | Reading (dBuV) | AMP factor (dB) | Emission Level (dBuV/m) | Limits (dBuV/m) | Margin (dB) | Remark |
|-----|-------------|--------------------|-----------------|----------------|-----------------|-------------------------|-----------------|-------------|--------|
| 1   | 2402.00     | 28.28              | 8.34            | 78.37          | 36.39           | 78.60                   | 74.00           | -4.60       | Peak   |
| 2   | 4804.00     | 33.11              | 11.75           | 43.34          | 35.67           | 52.53                   | 74.00           | 21.47       | Peak   |
| 3   | 7206.00     | 35.99              | 12.44           | 42.76          | 35.55           | 55.64                   | 74.00           | 18.36       | Peak   |

Remarks: 1. Emission Level= Antenna Factor + Cable Loss + Reading - Amp Factor  
 2. The emission levels that are 20dB below the official limit are not reported.

| Frequency ( MHz ) | Original AV level ( dBuv/m ) | Duty cycle factor (dB) | Final AV level (dBuv/m) | Limit(dBuv/m) | Conclusion |
|-------------------|------------------------------|------------------------|-------------------------|---------------|------------|
| 7206.00           | 55.64                        | -30.722                | 24.918                  | 54            | Pass       |

## 5. CONDUCTED SPURIOUS EMISSIONS

### 5.1. Test Equipment

| Item | Equipment         | Manufacturer            | Model No.     | Serial No. | Last Cal. | Cal. Interval |
|------|-------------------|-------------------------|---------------|------------|-----------|---------------|
| 1.   | Spectrum          | Agilent                 | N9030A        | MY51380221 | Oct.17,15 | 1 Year        |
| 2.   | Attenuator (20dB) | Agilent                 | 8491B         | MY39262165 | Apr.23,16 | 1 Year        |
| 3.   | RF Cable          | Marvelous Microwave Inc | SFL402105FLEX | NO.1       | Oct.17,15 | 1 Year        |

### 5.2. Limit

In any 100kHz bandwidth outside the frequency bands in which the spread spectrum intentional radiator is operating, the radio frequency power that is produced by the intentional radiator shall be at least 20dB below that in the 100kHz bandwidth within the band that contains the highest level of the desired power.

### 5.3. Test Procedure

The transmitter output was connected to a spectrum analyzer, The resolution bandwidth is set to 100 kHz, The video bandwidth is set to 300 kHz and measure all the emissions detected.

### 5.4. Test result

**PASS** (The testing data was attached in the next pages.)



**Hopping Off  
GFSK  
2402MHz**

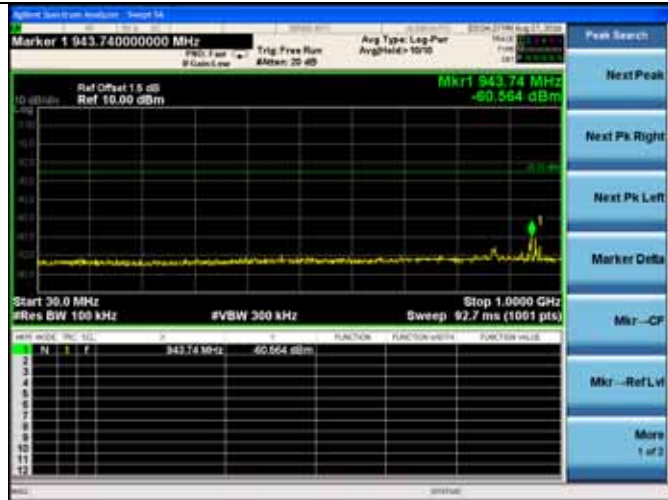

**2441MHz**

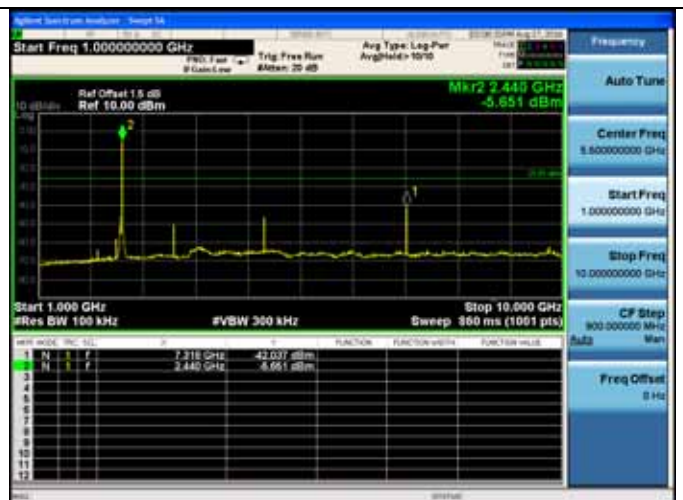
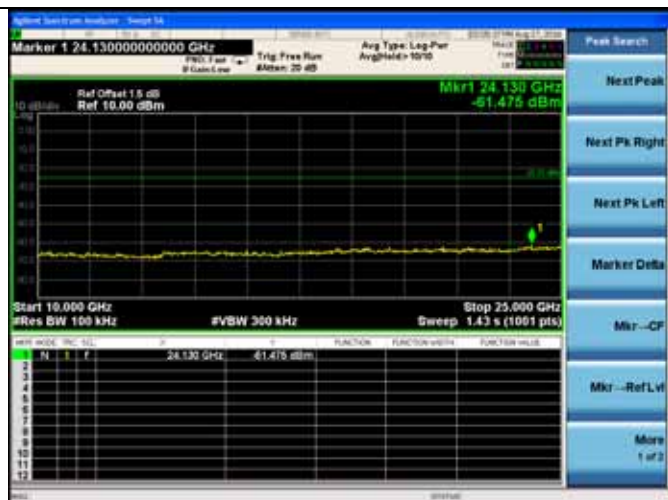
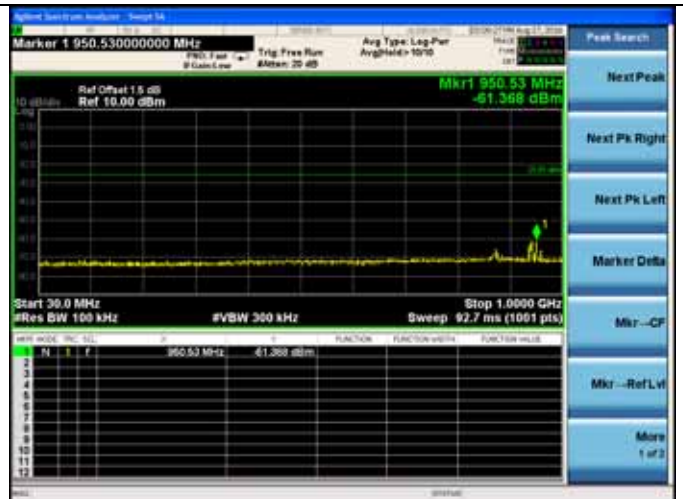
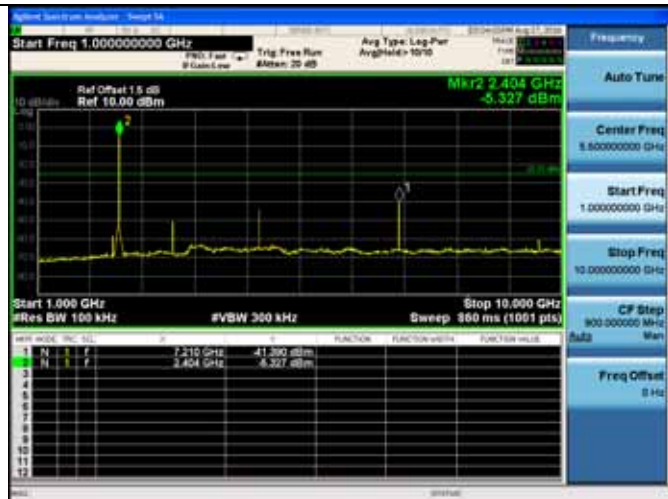

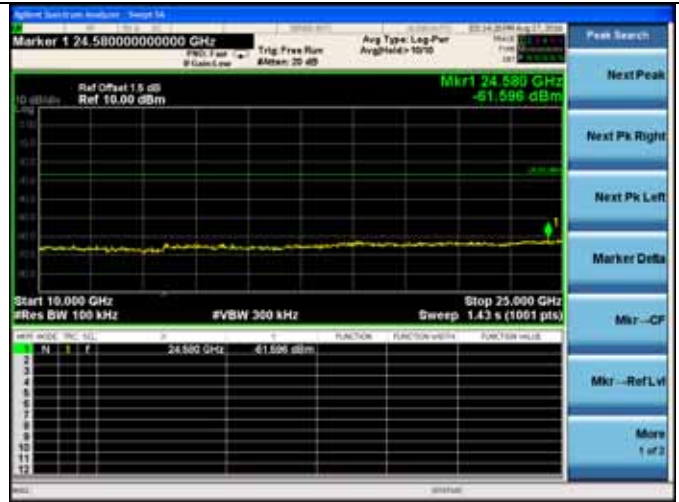
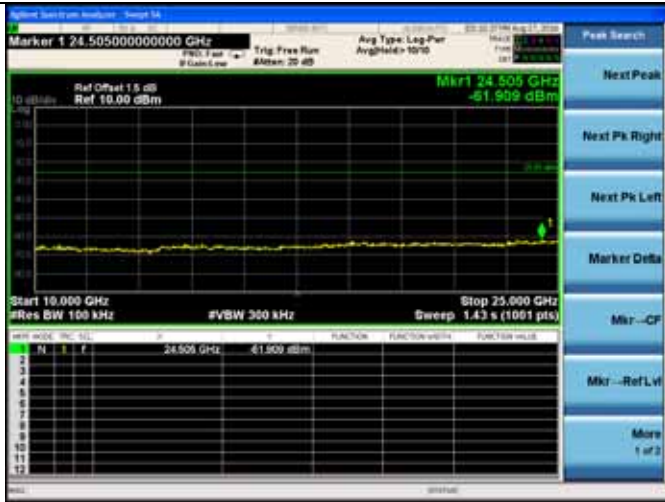

2480MHz

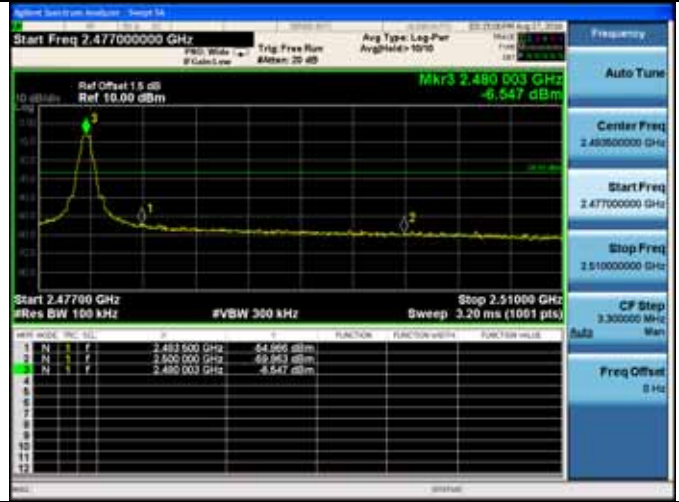
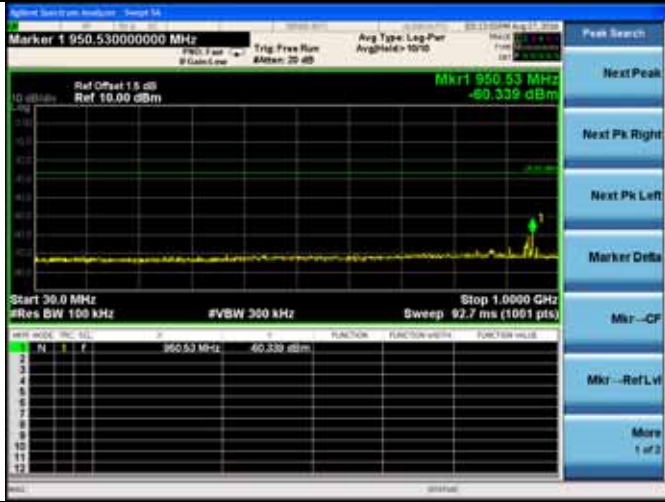

8-DPSK  
2402MHz

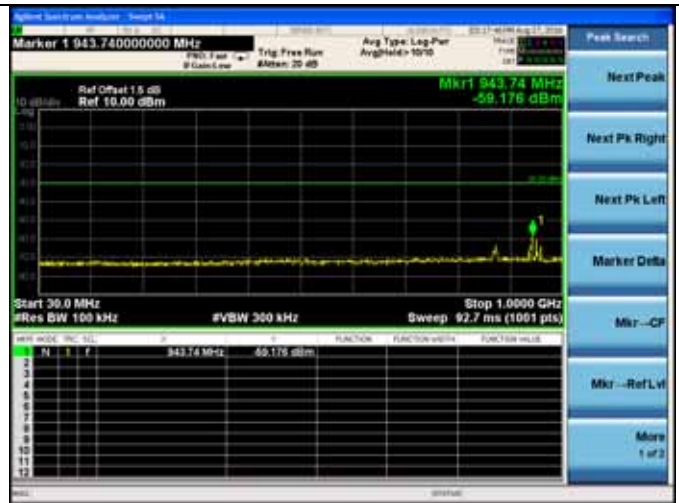
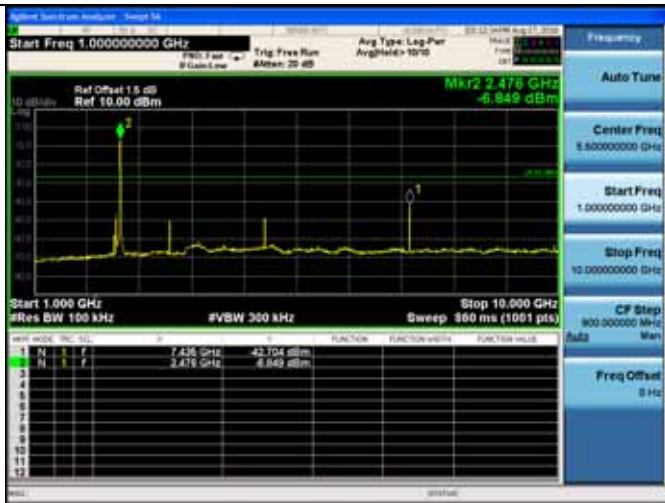

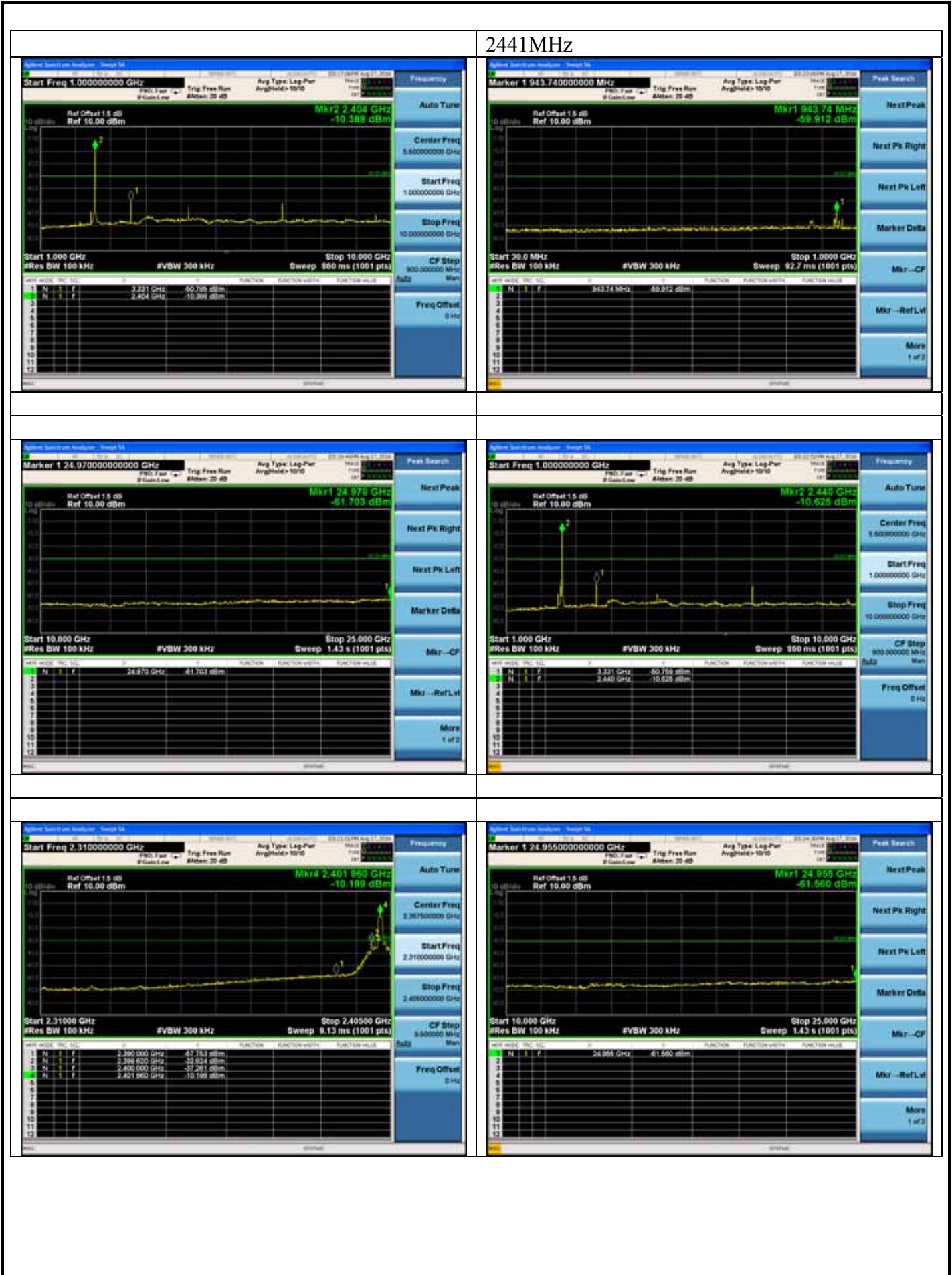

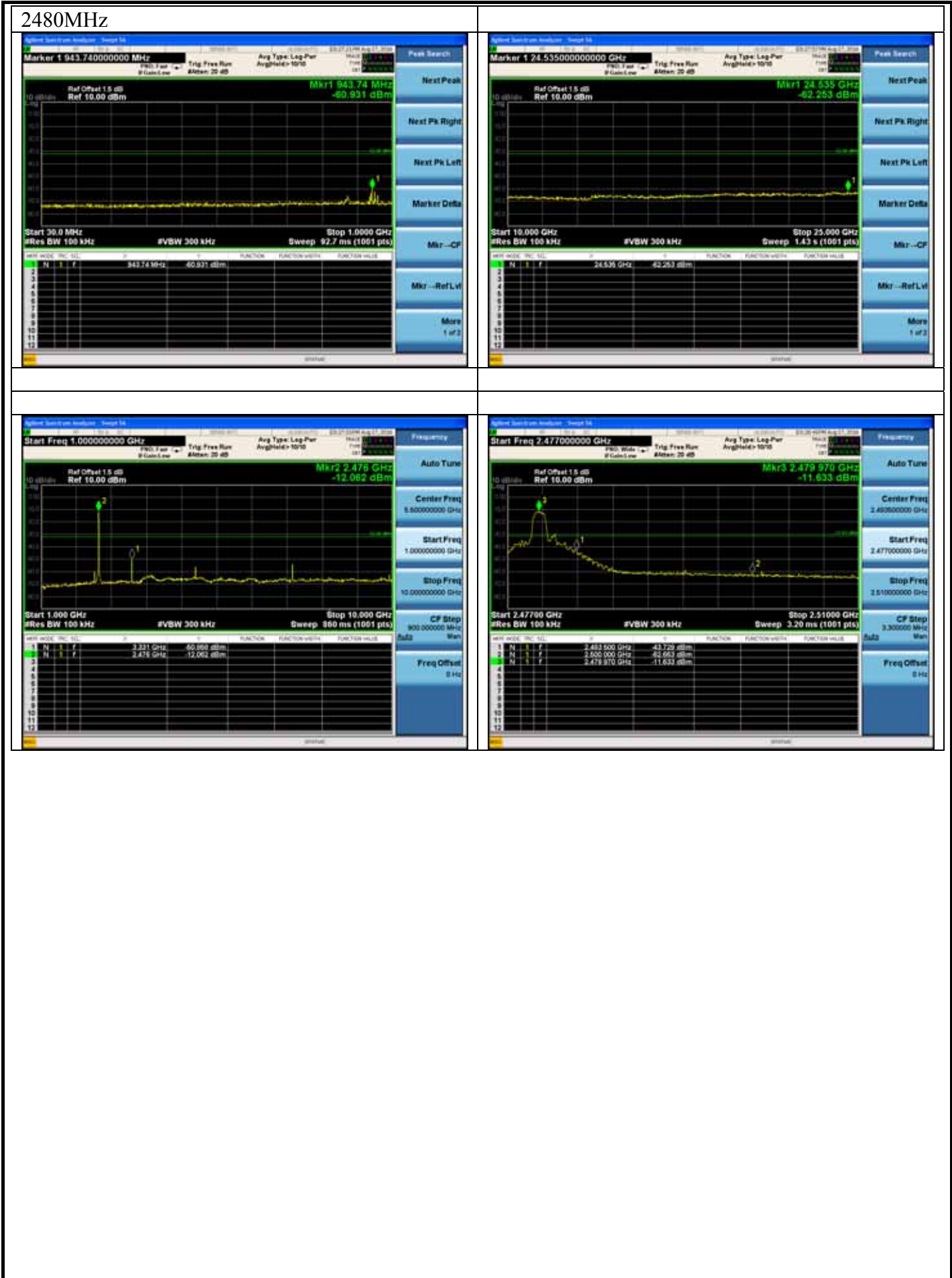

**Hopping On  
GFSK**

**8-DPSK**

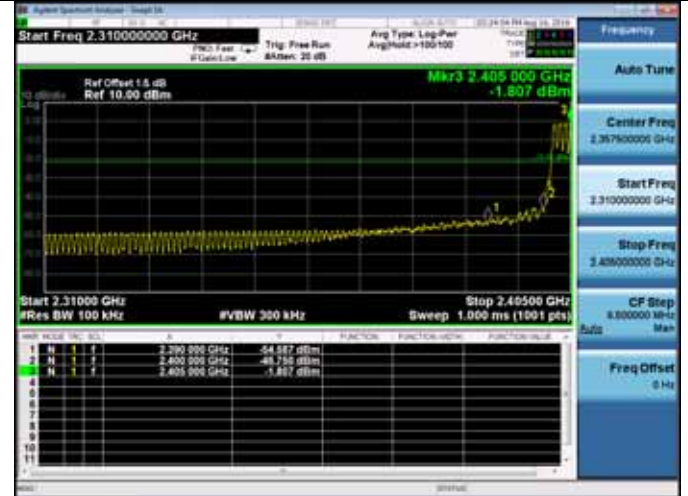
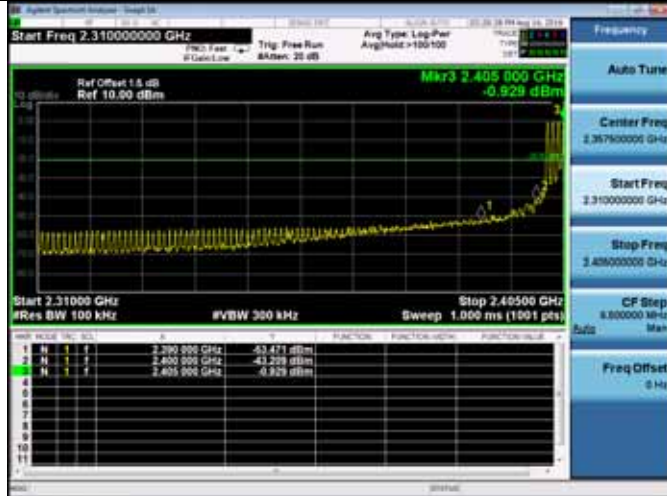

## 6. CARRIER FREQUENCY SEPARATION TEST

### 6.1. Test Equipment

| Item | Equipment         | Manufacturer            | Model No.     | Serial No. | Last Cal. | Cal. Interval |
|------|-------------------|-------------------------|---------------|------------|-----------|---------------|
| 1    | Spectrum Analyzer | Agilent                 | N9030A        | MY51380221 | Oct.18,15 | 1 Year        |
| 2.   | RF Cable          | Marvelous Microwave Inc | SFL402105FLEX | NO.1       | Oct.17,15 | 1 Year        |

### 6.2. Limit

Frequency hopping systems shall have hopping channel carrier frequency separated by a minimum of 25kHz or the 20dB bandwidth of the hopping channel, whichever is greater. Alternatively, frequency hopping systems operating in the 2400-2483.5 MHz band may have hopping channel carrier frequencies that are separated by 25 kHz or two-thirds of the 20 dB bandwidth of the hopping channel, whichever is greater, provided the systems operate with an output power no greater than 125 mW.

### 6.3. Test Results.

|                             |                         |                       |
|-----------------------------|-------------------------|-----------------------|
| EUT: Mobile wall mount unit |                         |                       |
| M/N: JWM1A                  |                         |                       |
| Test date: 2016-08-16       | Pressure: 101.4±1.0 kpa | Humidity: 51.5±3.0%   |
| Tested by: Donjon_Huang     | Test site: RF Site      | Temperature: 22.3±0.6 |

| Test Mode | Channel separation | Conclusion |
|-----------|--------------------|------------|
| 8-DPSK    | 1.0MHz             | PASS       |
| GFSK      | 1.0MHz             | PASS       |



## 7. 20 DB BANDWIDTH TEST

### 7.1. Test Equipment

| Item | Equipment         | Manufacturer            | Model No.     | Serial No. | Last Cal. | Cal. Interval |
|------|-------------------|-------------------------|---------------|------------|-----------|---------------|
| 1.   | Spectrum          | Agilent                 | N9030A        | MY51380221 | Oct.18,15 | 1 Year        |
| 2.   | Attenuator (20dB) | Agilent                 | 8491B         | MY39262165 | Apr.23,16 | 1 Year        |
| 3.   | RF Cable          | Marvelous Microwave Inc | SFL402105FLEX | NO.1       | Oct.17.15 | 1 Year        |

### 7.2. Limit

Intentional radiators operating under the alternative provisions to the general emission limits, as contained in §§ 15.217 through 15.257 and in Subpart E of this part, must be designed to ensure that the 20 dB bandwidth of the emission, or whatever bandwidth may otherwise be specified in the specific rule section under which the equipment operates, is contained within the frequency band designated in the rule section under which the equipment is operated.

### 7.3. Test Results

|                             |                         |                       |
|-----------------------------|-------------------------|-----------------------|
| EUT: Mobile wall mount unit |                         |                       |
| M/N: JWM1A                  |                         |                       |
| Test date: 2016-08-17       | Pressure: 101.5±1.0 kpa | Humidity: 52.4±3.0%   |
| Tested by: Donjon_Huang     | Test site: RF Site      | Temperature: 25.1±0.6 |

| Test Mode | Frequency ( MHz ) | -20dB Bandwidth ( KHz ) | Limit (KHz) |
|-----------|-------------------|-------------------------|-------------|
| GFSK      | 2402              | 1104                    | N/A         |
|           | 2441              | 1101                    | N/A         |
|           | 2480              | 1106                    | N/A         |
| 8-DPSK    | 2402              | 1372                    | N/A         |
|           | 2441              | 1375                    | N/A         |
|           | 2480              | 2038                    | N/A         |

Conclusion : PASS

**GFSK**

Test Frequency: 2402MHz



**8-DPSK**

Test Frequency: 2402MHz

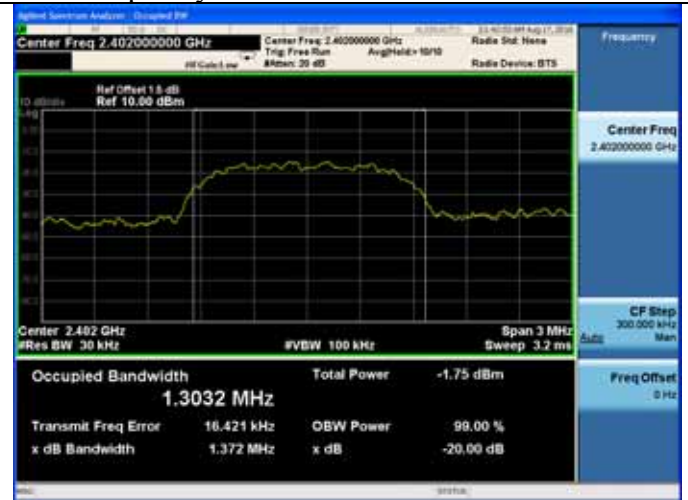

Test Frequency: 2441MHz



Test Frequency: 2441MHz

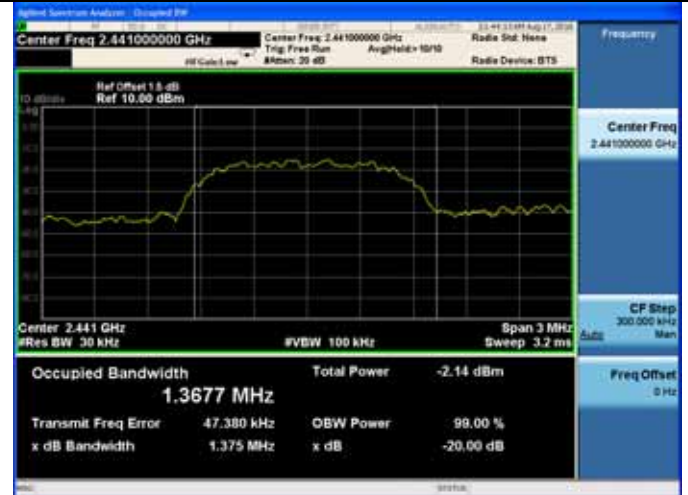

Test Frequency: 2480MHz



Test Frequency: 2480MHz

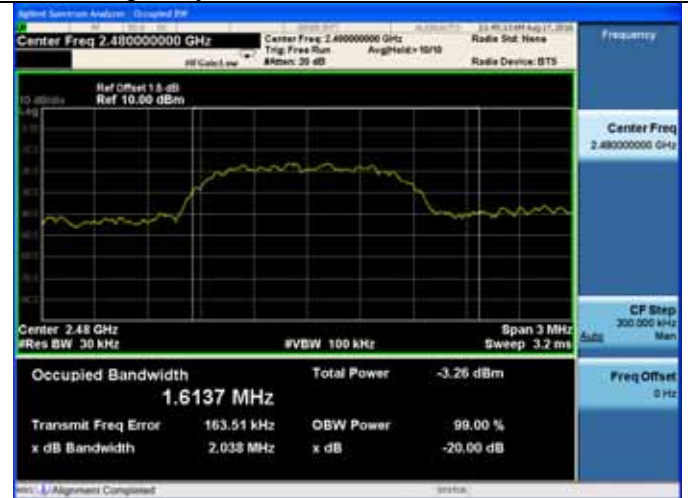



## 8. NUMBER OF HOPPING FREQUENCY TEST

### 8.1. Test Equipment

| Item | Equipment         | Manufacturer            | Model No.     | Serial No. | Last Cal. | Cal. Interval |
|------|-------------------|-------------------------|---------------|------------|-----------|---------------|
| 1    | Spectrum Analyzer | Agilent                 | N9030A        | MY53311015 | Oct.18,15 | 1 Year        |
| 2.   | RF Cable          | Marvelous Microwave Inc | SFL402105FLEX | NO.1       | Oct.17,15 | 1 Year        |

### 8.2. Limit

Frequency hopping systems in the 2400-2483.5 MHz band shall use at least 15 channels

### 8.3. Test Results

|                             |                         |                       |
|-----------------------------|-------------------------|-----------------------|
| EUT: Mobile wall mount unit |                         |                       |
| M/N: JWM1A                  |                         |                       |
| Test date: 2016-08-16       | Pressure: 101.4±1.0 kpa | Humidity: 51.5±3.0%   |
| Tested by: Donjon_Huang     | Test site: RF Site      | Temperature: 22.3±0.6 |

| Test Mode | Number of channel | Limit | Conclusion |
|-----------|-------------------|-------|------------|
| 8-DPSK    | 79                | ≥15   | PASS       |
| GFSK      | 79                | ≥15   | PASS       |

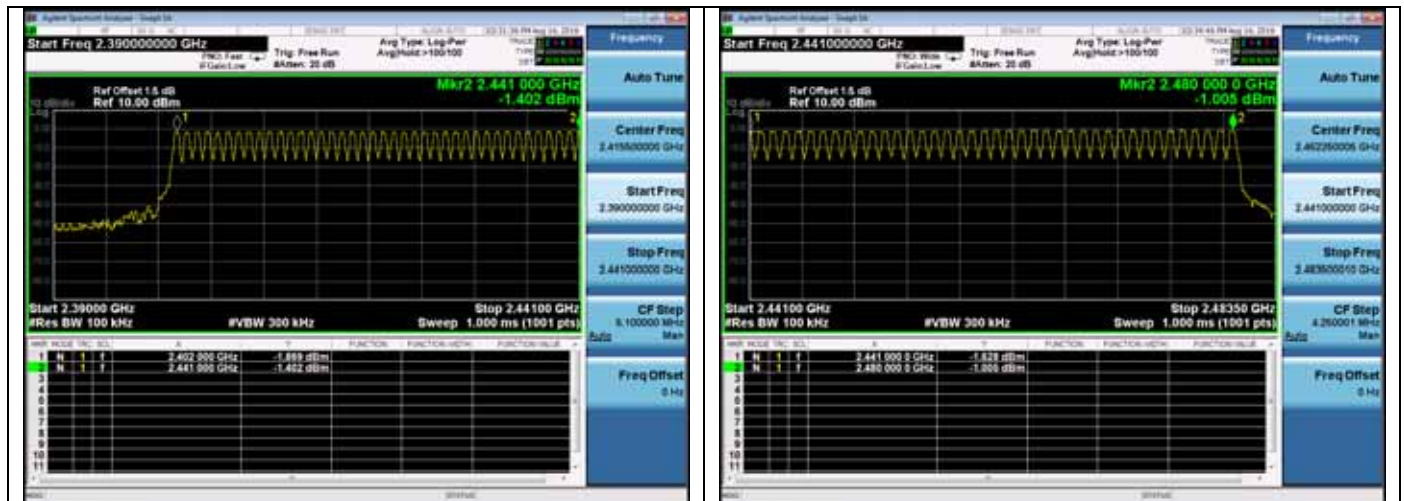

## 9. DWELL TIME

### 9.1. Test Equipment

| Item | Equipment         | Manufacturer            | Model No.     | Serial No. | Last Cal. | Cal. Interval |
|------|-------------------|-------------------------|---------------|------------|-----------|---------------|
| 1    | Spectrum Analyzer | Agilent                 | N9030A        | MY51380221 | Oct.18,15 | 1Year         |
| 2.   | RF Cable          | Marvelous Microwave Inc | SFL402105FLEX | NO.1       | Oct.17,15 | 1 Year        |

### 9.2. Limit

The average time of occupancy on any channel shall not be greater than 0.4 seconds within a period of 0.4 seconds multiplied by the number of hopping channels employed.

### 9.3. Test Results

|                             |                         |                       |
|-----------------------------|-------------------------|-----------------------|
| EUT: Mobile wall mount unit |                         |                       |
| M/N: JWM1A                  |                         |                       |
| Test date: 2016-08-16       | Pressure: 101.4±1.0 kpa | Humidity: 51.5±3.0%   |
| Tested by: Donjon_Huang     | Test site: RF Site      | Temperature: 22.3±0.6 |

| Mode   |     | dwell time   | Limit  | Conclusion |
|--------|-----|--|--------|------------|
| GFSK   | DH1 | $48\text{hops}/5\text{s} * 0.4 * 79\text{chanel} * 0.468\text{ms} = 141.972\text{ms}$  | <400ms | PASS       |
|        | DH3 | $27\text{hops}/5\text{s} * 0.4 * 79\text{chanel} * 1.7730\text{ms} = 302.545\text{ms}$ | <400ms | PASS       |
|        | DH5 | $18\text{hops}/5\text{s} * 0.4 * 79\text{chanel} * 2.9000\text{ms} = 329.904\text{ms}$ | <400ms | PASS       |
| 8-DPSK | DH1 | $48\text{hops}/5\text{s} * 0.4 * 79\text{chanel} * 0.4288\text{ms} = 129.838\text{ms}$ | <400ms | PASS       |
|        | DH3 | $27\text{hops}/5\text{s} * 0.4 * 79\text{chanel} * 1.818\text{ms} = 310.224\text{ms}$  | <400ms | PASS       |
|        | DH5 | $18\text{hops}/5\text{s} * 0.4 * 79\text{chanel} * 2.890\text{ms} = 328.766\text{ms}$  | <400ms | PASS       |

Note: All the lower levels were signal from receiver's, and should not considered in here.

**GFSK**  
DH 1

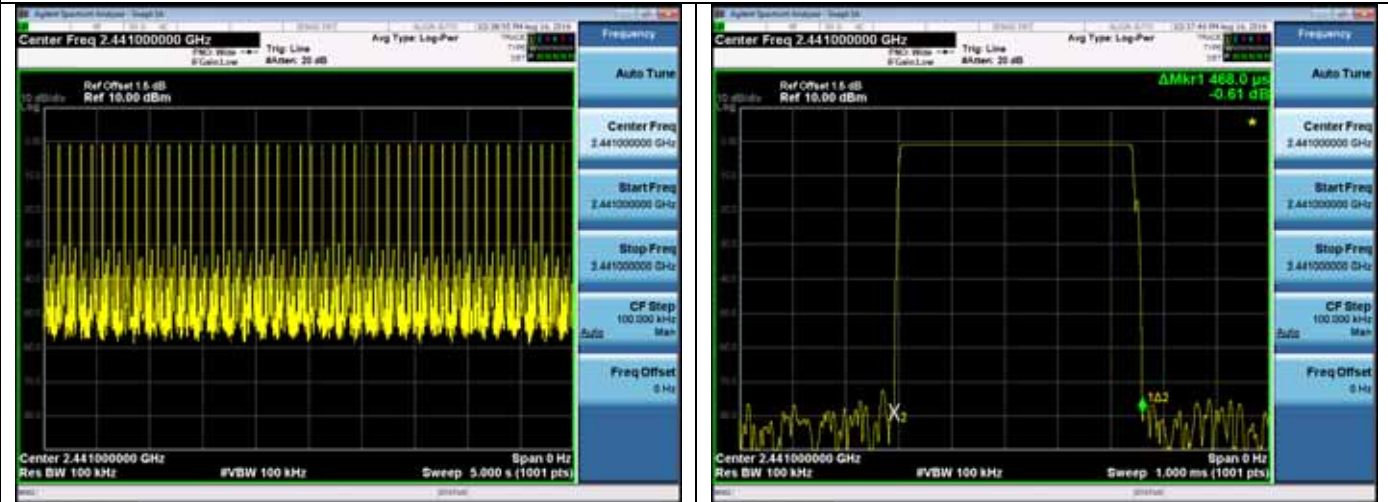

**DH 3**

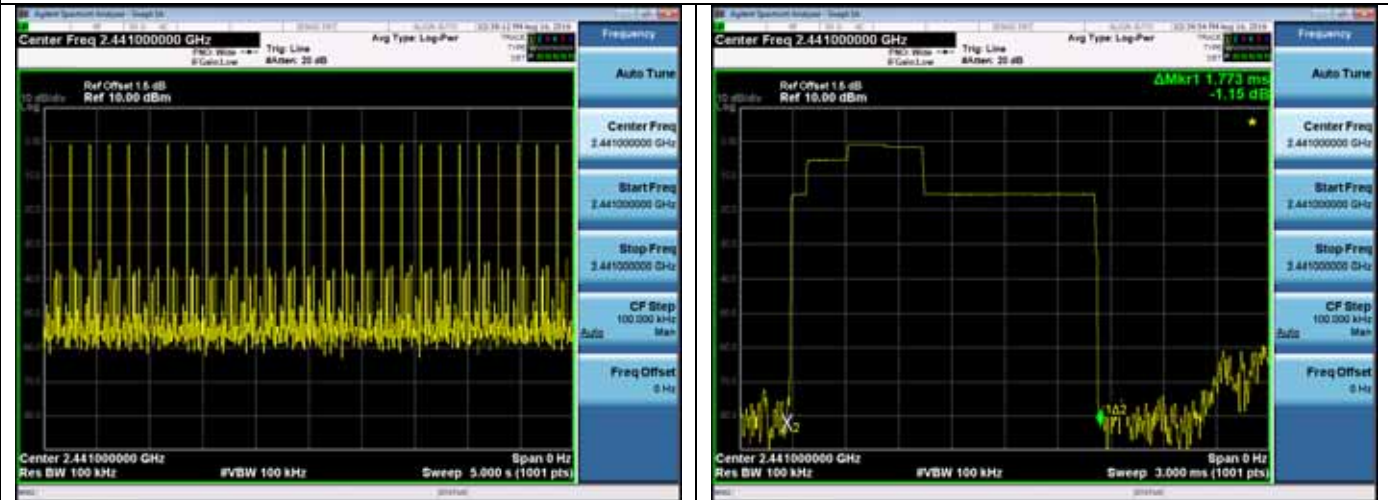

**DH 5**

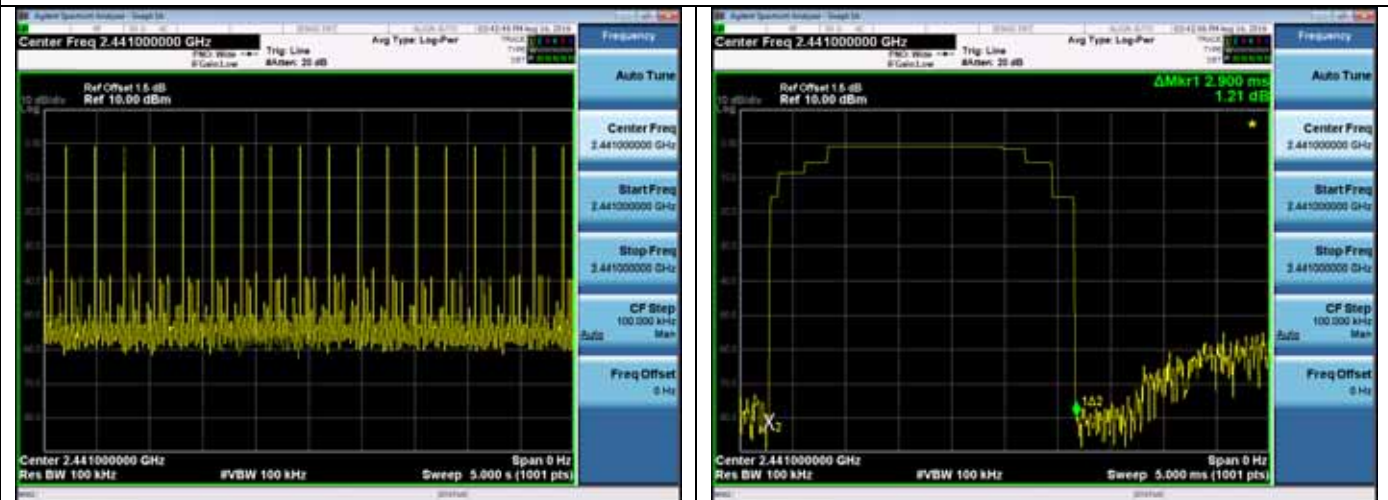

**8-DPSK**  
**3-DH 1**

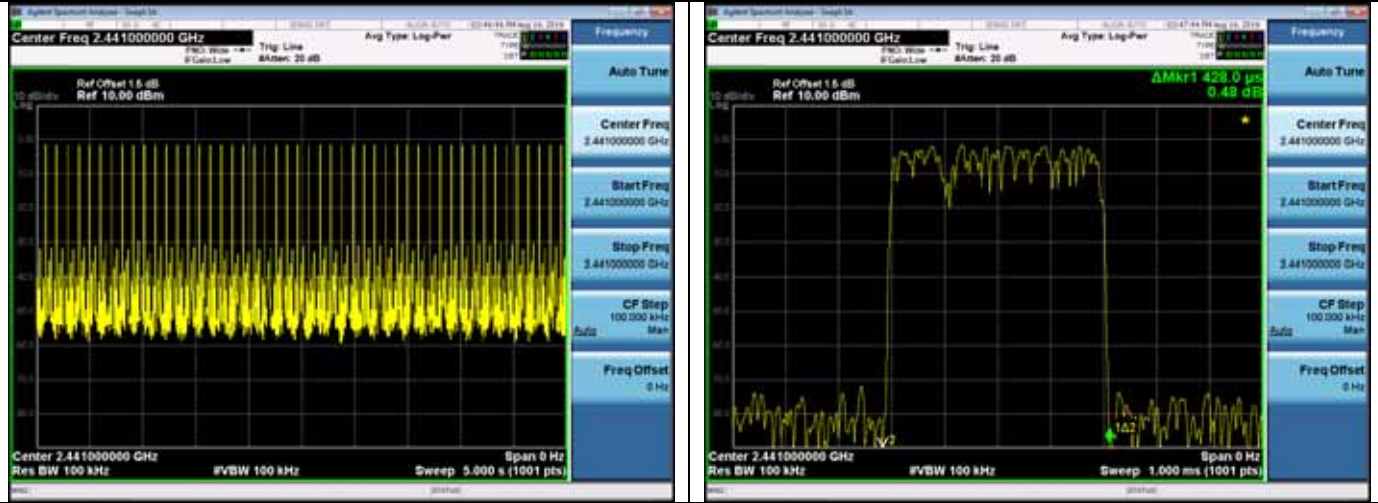

**3-DH 3**

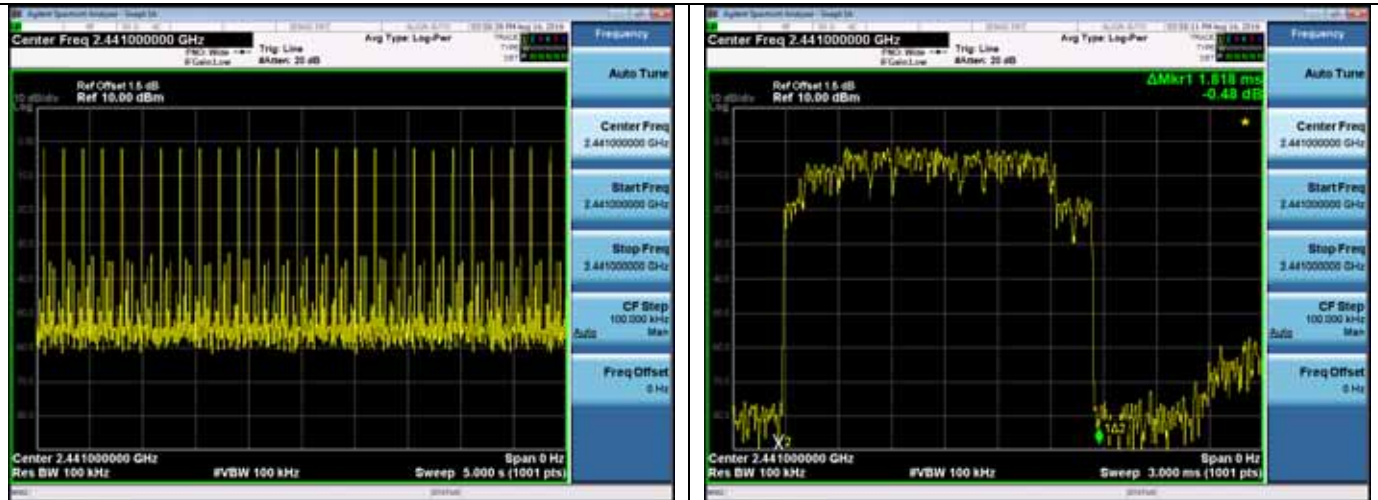

**3-DH 5**

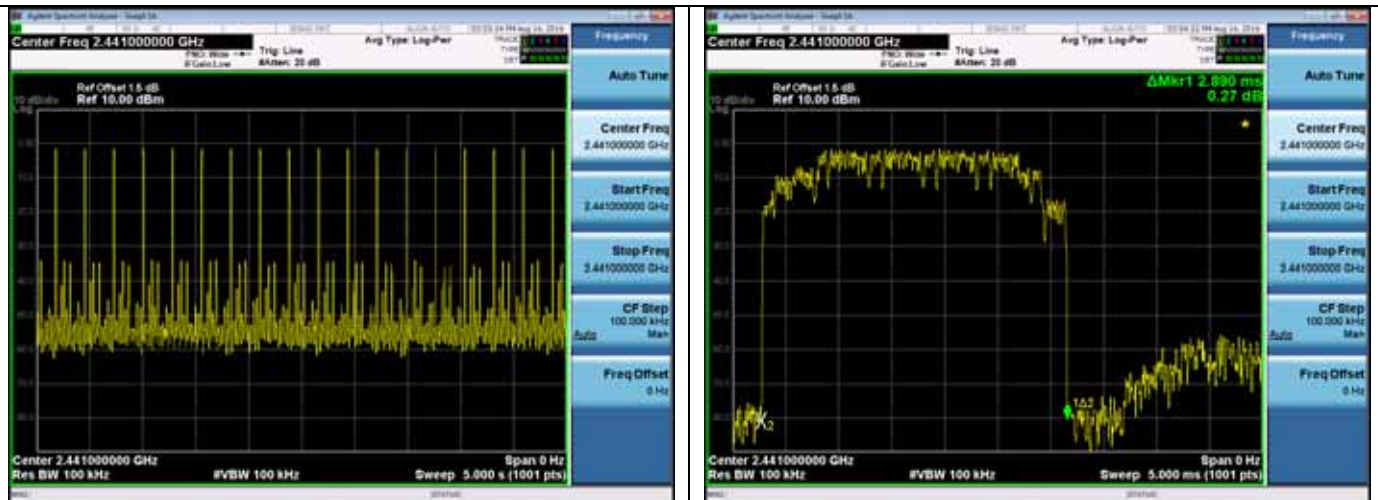

## 10. MAXIMUM PEAK OUTPUT POWER TEST

### 10.1. Test Equipment

| Item | Equipment         | Manufacturer            | Model No.     | Serial No. | Last Cal. | Cal. Interval |
|------|-------------------|-------------------------|---------------|------------|-----------|---------------|
| 1.   | Spectrum          | Agilent                 | E4446A        | US44300459 | Apr.24,16 | 1 Year        |
| 2.   | Spectrum          | Agilent                 | N9030A        | MY51380221 | Oct.18,15 | 1 Year        |
| 3.   | Power meter       | Anritsu                 | ML2487A       | 6K00002472 | Apr.23,16 | 1 Year        |
| 4.   | Power sensor      | Anritsu                 | MA2491A       | 0033005    | Apr.23,16 | 1 Year        |
| 5.   | Attenuator (20dB) | Agilent                 | 8491B         | MY39262165 | Apr.23,16 | 1 Year        |
| 6.   | RF Cable          | Marvelous Microwave Inc | SFL402105FLEX | NO.1       | Oct.17,15 | 1 Year        |

### 10.2. Limit

For frequency hopping systems operating in the 2400-2483.5 MHz band employing at least 75 non-overlapping hopping channels, and all frequency hopping systems in the 5725-5850 MHz band: 1 watt. For all other frequency hopping systems in the 2400-2483.5 MHz band: 0.125 watts.

### 10.3. Test Procedure

The power meter was used to measure for 2400-2483.5MHz band that is the peak output power directly.

### 10.4. Test Results

| EUT: Mobile wall mount unit |                 |                           |                       |
|-----------------------------|-----------------|---------------------------|-----------------------|
| M/N: JWM1A                  |                 |                           |                       |
| Test date: 2016-08-19       |                 | Pressure: 101.5±1.0 kpa   | Humidity: 52.3±1.0%   |
| Tested by: Donjon_Huang     |                 | Test site: RF site        | Temperature: 25.3±1.0 |
| Test Mode                   | Frequency (MHz) | Peak output Power ( dBm ) | Limit (dBm)           |
| GFSK                        | 2402            | -4.696                    | 30                    |
|                             | 2441            | -5.232                    | 30                    |
|                             | 2480            | -6.318                    | 30                    |
| 8-DPSK                      | 2402            | -5.968                    | 30                    |
|                             | 2441            | -6.358                    | 30                    |
|                             | 2480            | -7.427                    | 30                    |
| Conclusion: PASS            |                 |                           |                       |

## 11. BAND EDGE COMPLIANCE TEST

### 11.1. Test Equipment

| Item | Equipment    | Manufacturer | Model No.   | Serial No. | Last Cal. | Cal. Interval |
|------|--------------|--------------|-------------|------------|-----------|---------------|
| 1.   | Amp          | HP           | 8449B       | 3008A02495 | Apr.24,16 | 1 Year        |
| 2.   | Horn Antenna | ETS          | 3115        | 9510-4877  | Oct.15,15 | 1 Year        |
| 3.   | HF Cable     | Hubersuhner  | Sucoflex104 | 274094/4   | Apr.24,16 | 1 Year        |

### 11.2. Limit

All the lower and upper band-edges emissions appearing within 2310MHz to 2390MHz and 2483.5MHz to 2500MHz restricted frequency bands shall not exceed the limits shown in 15.209, all the other emissions outside operation frequency band 2400MHz to 2483.5MHz shall be at least 20dB below the fundamental emissions, or comply with 15.209 limits.

### 11.3. Test Produce

For upper band emissions that are up to two bandwidths(2MHz) away (2483.5MHz to 2485.5MHz ) from the band-edge use below produce:

1. Choose a spectrum analyzer span that encompasses both the peak of the fundamental emission and the band-edge emission under investigation. Set the analyzer RBW to 100KHz and with a video bandwidth 300KHz. Record the peak levels of the fundamental emission and the relevant band-edge emission, Observe the stored trace and measure the amplitude delta between the peak of the fundamental and the peak of the band-edge emission. This is not a field strength measurement, it is only a relative measurement to determine the amount by which the emission drops at the band edge relative to the highest fundamental emission level.
2. Subtract the delta measured in step (1) from the maximum field strengths measured in clause 4 .The resultant field strengths are then used to determine band-edge compliance as required by Section 15.205

For emissions above two bandwidths away from the band-edge use below produce:

1. The EUT is placed on a turntable, which is 0.8m above the ground plane and worked at highest radiated power.
2. The turntable was rotated for 360 degrees to determine the position of maximum emission level.
3. EUT is set 3m away from the receiving antenna, which is varied from 1m to 4m to find out the highest emission.
4. Set the spectrum analyzer in the following setting in order to capture the lower and upperband-edges of the emission:
  - (a) PEAK: RBW=1MHz ;VBW=3MHz, PK detector, Sweep=AUTO
  - (b) This is pulse Modulation device a duty cycle factor was used to calculate average level based measured peak level.

### 11.4. Test Results

Pass (The testing data was attached in the next pages.)

Note: If the PK measured levels comply with average limit, then the average level were deemed to comply with average limit.

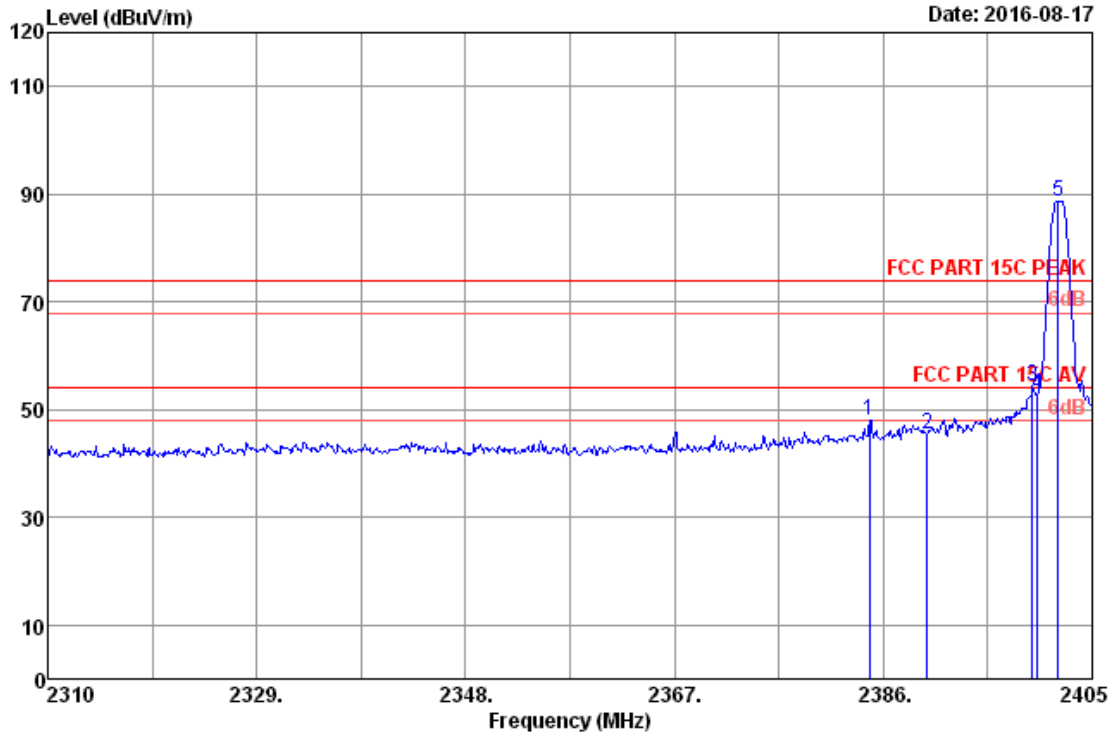

Site no. : RF Chamber  
 Dis. / Ant. : 3m 2015 3115-4877  
 Limit : FCC PART 15C PEAK  
 Env. / Ins. : 22.6°C/51.2%  
 EUT : Mobile wall mount unit  
 Power rating : DC 12V  
 Test Mode : GFSK 2402MHz Tx Mode  
 M/N : JWM1A  
 Data no. : 5  
 Ant. pol. : HORIZONTAL  
 Pre : 101.2kPa  
 Engineer : Donjon\_Huang

| No. | Freq. (MHz) | Ant. Factor (dB/m) | Cable Loss (dB) | Reading (dBUV) | AMP factor (dB) | Emission Level (dBUV/m) | Limits (dBUV/m) | Margin (dB) | Remark |
|-----|-------------|--------------------|-----------------|----------------|-----------------|-------------------------|-----------------|-------------|--------|
| 1   | 2384.77     | 28.26              | 8.32            | 47.66          | 36.39           | 47.85                   | 74.00           | 26.15       | Peak   |
| 2   | 2390.00     | 28.27              | 8.33            | 45.15          | 36.39           | 45.36                   | 74.00           | 28.64       | Peak   |
| 3   | 2399.59     | 28.28              | 8.34            | 54.30          | 36.39           | 54.53                   | 74.00           | 19.47       | Peak   |
| 4   | 2400.00     | 28.28              | 8.34            | 52.68          | 36.39           | 52.91                   | 74.00           | 21.09       | Peak   |
| 5   | 2401.87     | 28.28              | 8.34            | 88.50          | 36.39           | 88.73                   | 74.00           | -14.73      | Peak   |

Remarks: 1. Emission Level= Antenna Factor + Cable Loss + Reading - Amp Factor  
 2. The emission levels that are 20dB below the official limit are not reported.

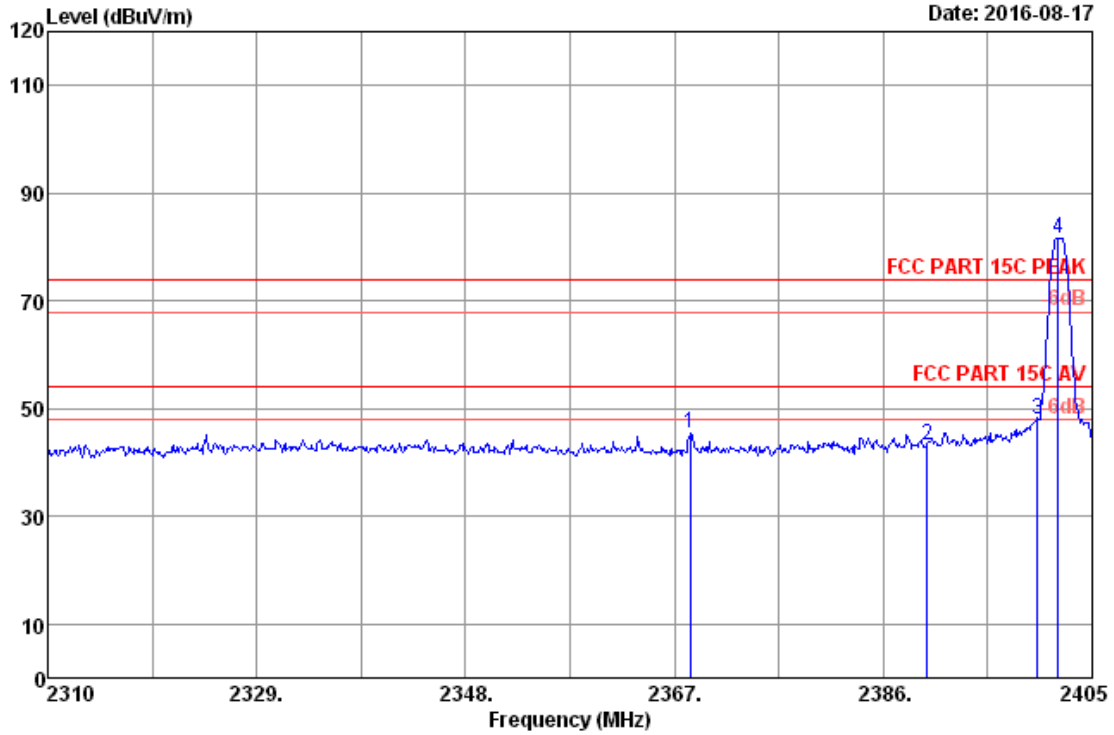

Site no. : RF Chamber Data no. : 6  
 Dis. / Ant. : 3m 2015 3115-4877 Ant. pol. : VERTICAL  
 Limit : FCC PART 15C PEAK Pre : 101.2kPa  
 Env. / Ins. : 22.6°C/51.2% Engineer : Donjon\_Huang  
 EUT : Mobile wall mount unit  
 Power rating : DC 12V  
 Test Mode : GFSK 2402MHz Tx Mode  
 M/N : JWM1A

| No. | Freq. (MHz) | Ant. Factor (dB/m) | Cable Loss (dB) | Reading (dBuV) | AMP factor (dB) | Emission Level (dBuV/m) | Limits (dBuV/m) | Margin (dB) | Remark |
|-----|-------------|--------------------|-----------------|----------------|-----------------|-------------------------|-----------------|-------------|--------|
| 1   | 2368.43     | 28.24              | 8.31            | 45.33          | 36.39           | 45.49                   | 74.00           | 28.51       | Peak   |
| 2   | 2390.00     | 28.27              | 8.33            | 42.86          | 36.39           | 43.07                   | 74.00           | 30.93       | Peak   |
| 3   | 2400.00     | 28.28              | 8.34            | 47.75          | 36.39           | 47.98                   | 74.00           | 26.02       | Peak   |
| 4   | 2401.87     | 28.28              | 8.34            | 81.44          | 36.39           | 81.67                   | 74.00           | -7.67       | Peak   |

Remarks: 1. Emission Level= Antenna Factor + Cable Loss + Reading - Amp Factor  
 2. The emission levels that are 20dB below the official limit are not reported.



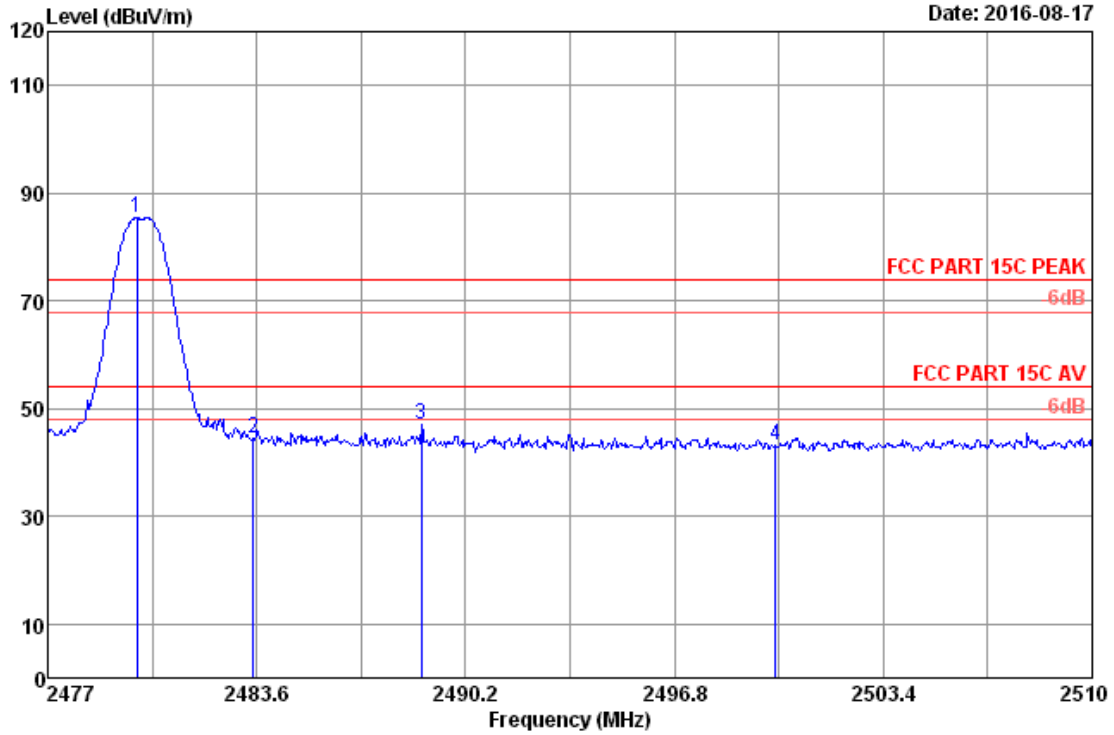

Date: 2016-08-17

Site no. : RF Chamber Data no. : 15  
 Dis. / Ant. : 3m 2015 3115-4877 Ant. pol. : HORIZONTAL  
 Limit : FCC PART 15C PEAK Pre : 101.2kPa  
 Env. / Ins. : 22.6°C/51.2% Engineer : Donjon\_Huang  
 EUT : Mobile wall mount unit  
 Power rating : DC 12V  
 Test Mode : GFSK 2480MHz Tx Mode  
 M/N : JWM1A

| No. | Freq. (MHz) | Ant. Factor (dB/m) | Cable Loss (dB) | Reading (dBuV) | AMP factor (dB) | Emission Level (dBuV/m) | Limits (dBuV/m) | Margin (dB) | Remark |
|-----|-------------|--------------------|-----------------|----------------|-----------------|-------------------------|-----------------|-------------|--------|
| 1   | 2479.81     | 28.38              | 8.42            | 84.93          | 36.38           | 85.35                   | 74.00           | -11.35      | Peak   |
| 2   | 2483.50     | 28.38              | 8.42            | 43.98          | 36.38           | 44.40                   | 74.00           | 29.60       | Peak   |
| 3   | 2488.81     | 28.39              | 8.43            | 46.60          | 36.38           | 47.04                   | 74.00           | 26.96       | Peak   |
| 4   | 2500.00     | 28.40              | 8.44            | 42.63          | 36.38           | 43.09                   | 74.00           | 30.91       | Peak   |

Remarks: 1. Emission Level= Antenna Factor + Cable Loss + Reading - Amp Factor  
 2. The emission levels that are 20dB below the official limit are not reported.

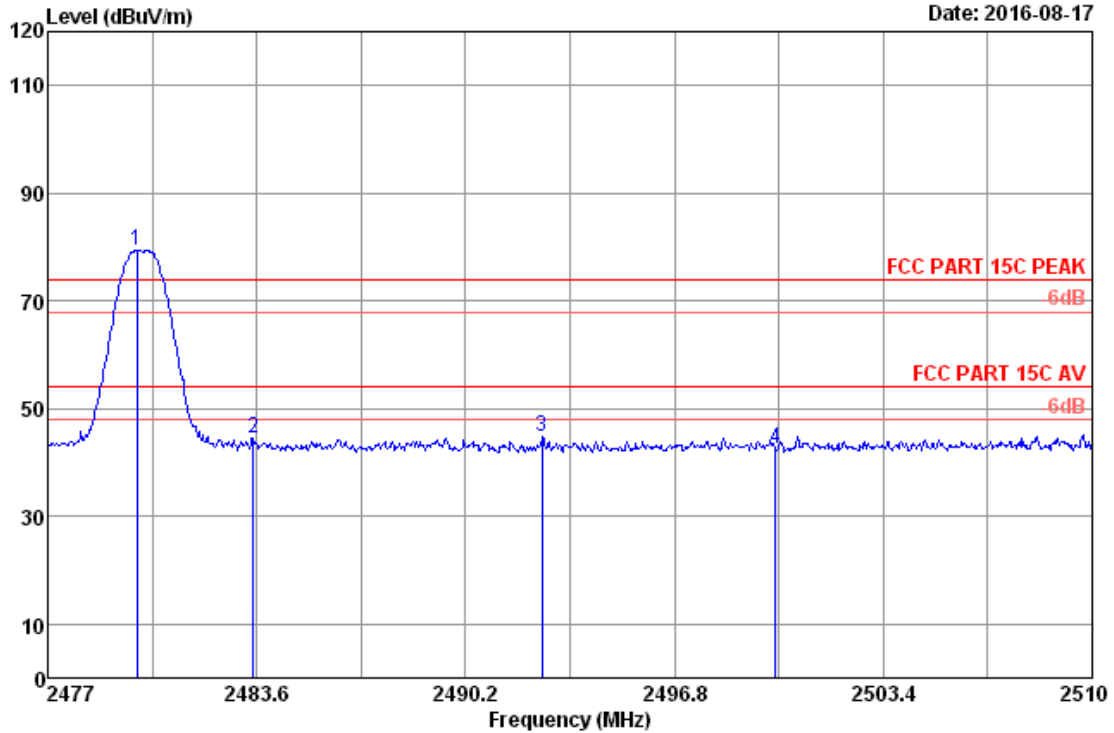

Site no. : RF Chamber Data no. : 16  
 Dis. / Ant. : 3m 2015 3115-4877 Ant. pol. : VERTICAL  
 Limit : FCC PART 15C PEAK Pre : 101.2kPa  
 Env. / Ins. : 22.6°C/51.2% Engineer : Donjon\_Huang  
 EUT : Mobile wall mount unit  
 Power rating : DC 12V  
 Test Mode : GFSK 2480MHz Tx Mode  
 M/N : JWM1A

| No. | Freq. (MHz) | Ant. Factor (dB/m) | Cable Loss (dB) | Reading (dBuV) | AMP factor (dB) | Emission Level (dBuV/m) | Limits (dBuV/m) | Margin (dB) | Remark |
|-----|-------------|--------------------|-----------------|----------------|-----------------|-------------------------|-----------------|-------------|--------|
| 1   | 2479.81     | 28.38              | 8.42            | 78.91          | 36.38           | 79.33                   | 74.00           | -5.33       | Peak   |
| 2   | 2483.50     | 28.38              | 8.42            | 44.05          | 36.38           | 44.47                   | 74.00           | 29.53       | Peak   |
| 3   | 2492.61     | 28.39              | 8.43            | 44.43          | 36.38           | 44.87                   | 74.00           | 29.13       | Peak   |
| 4   | 2500.00     | 28.40              | 8.44            | 42.13          | 36.38           | 42.59                   | 74.00           | 31.41       | Peak   |

Remarks: 1. Emission Level= Antenna Factor + Cable Loss + Reading - Amp Factor  
 2. The emission levels that are 20dB below the official limit are not reported.

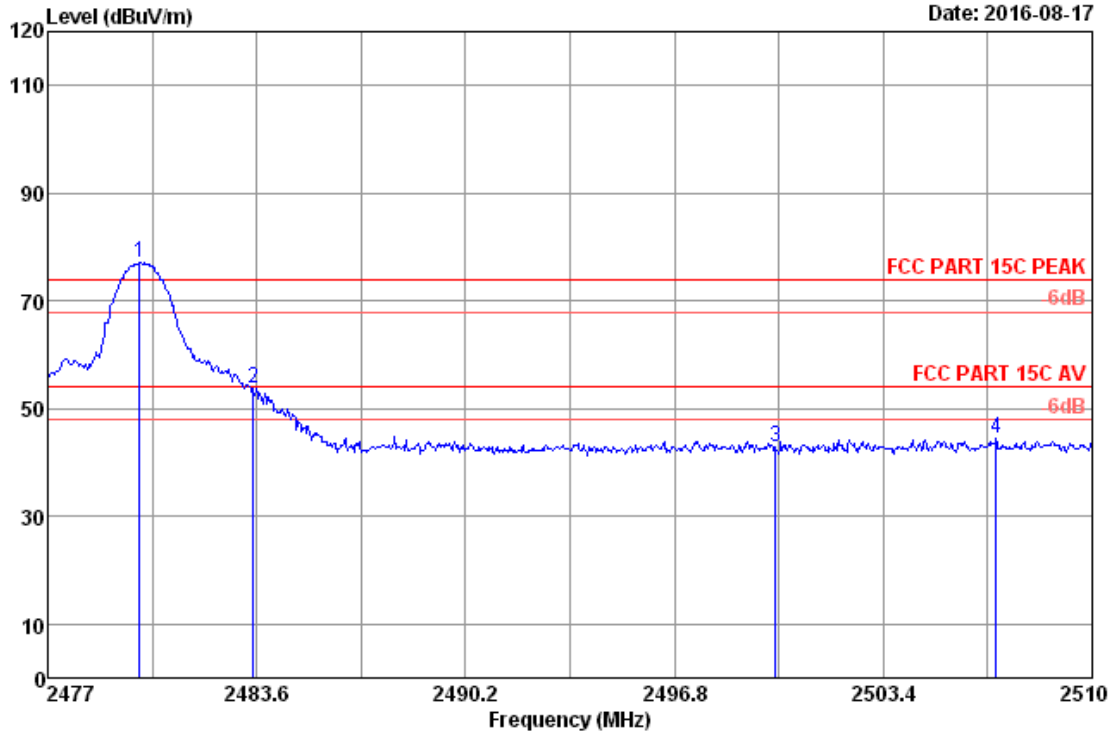

Site no. : RF Chamber Data no. : 17  
 Dis. / Ant. : 3m 2015 3115-4877 Ant. pol. : VERTICAL  
 Limit : FCC PART 15C PEAK Pre : 101.2kPa  
 Env. / Ins. : 22.6°C/51.2% Engineer : Donjon\_Huang  
 EUT : Mobile wall mount unit  
 Power rating : DC 12V  
 Test Mode : 8-DPSK 2480MHz Tx Mode  
 M/N : JWM1A

| No. | Freq. (MHz) | Ant. Factor (dB/m) | Cable Loss (dB) | Reading (dBuV) | AMP factor (dB) | Emission Level (dBuV/m) | Limits (dBuV/m) | Margin (dB) | Remark |
|-----|-------------|--------------------|-----------------|----------------|-----------------|-------------------------|-----------------|-------------|--------|
| 1   | 2479.90     | 28.38              | 8.42            | 76.69          | 36.38           | 77.11                   | 74.00           | -3.11       | Peak   |
| 2   | 2483.50     | 28.38              | 8.42            | 53.39          | 36.38           | 53.81                   | 74.00           | 20.19       | Peak   |
| 3   | 2500.00     | 28.40              | 8.44            | 42.32          | 36.38           | 42.78                   | 74.00           | 31.22       | Peak   |
| 4   | 2506.96     | 28.42              | 8.47            | 43.99          | 36.38           | 44.50                   | 74.00           | 29.50       | Peak   |

Remarks: 1. Emission Level= Antenna Factor + Cable Loss + Reading - Amp Factor  
 2. The emission levels that are 20dB below the official limit are not reported.

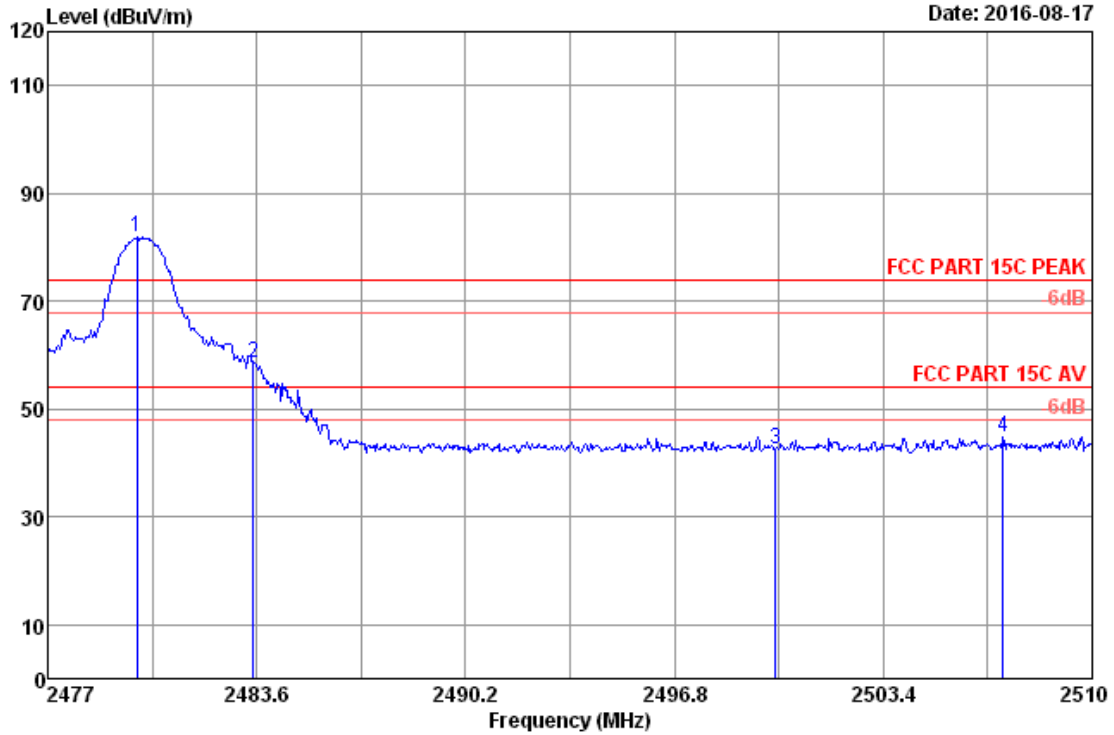

Site no. : RF Chamber Data no. : 18  
 Dis. / Ant. : 3m 2015 3115-4877 Ant. pol. : HORIZONTAL  
 Limit : FCC PART 15C PEAK Pre : 101.2kPa  
 Env. / Ins. : 22.6°C/51.2% Engineer : Donjon\_Huang  
 EUT : Mobile wall mount unit  
 Power rating : DC 12V  
 Test Mode : 8-DPSK 2480MHz Tx Mode  
 M/N : JWM1A

| No. | Freq. (MHz) | Ant. Factor (dB/m) | Cable Loss (dB) | Reading (dBuV) | AMP factor (dB) | Emission Level (dBuV/m) | Limits (dBuV/m) | Margin (dB) | Remark |
|-----|-------------|--------------------|-----------------|----------------|-----------------|-------------------------|-----------------|-------------|--------|
| 1   | 2479.81     | 28.38              | 8.42            | 81.40          | 36.38           | 81.82                   | 74.00           | -7.82       | Peak   |
| 2   | 2483.50     | 28.38              | 8.42            | 58.04          | 36.38           | 58.46                   | 74.00           | 15.54       | Peak   |
| 3   | 2500.00     | 28.40              | 8.44            | 42.07          | 36.38           | 42.53                   | 74.00           | 31.47       | Peak   |
| 4   | 2507.20     | 28.42              | 8.47            | 44.36          | 36.38           | 44.87                   | 74.00           | 29.13       | Peak   |

Remarks: 1. Emission Level= Antenna Factor + Cable Loss + Reading - Amp Factor  
 2. The emission levels that are 20dB below the official limit are not reported.

| Frequency ( MHz ) | Original AV level ( dBuV/m ) | Duty cycle factor (dB) | Final AV level (dBuV/m) | Limit(dBuv/m) | Conclusion |
|-------------------|------------------------------|------------------------|-------------------------|---------------|------------|
| 2483.50           | 58.46                        | -30.722                | 27.738                  | 54            | Pass       |

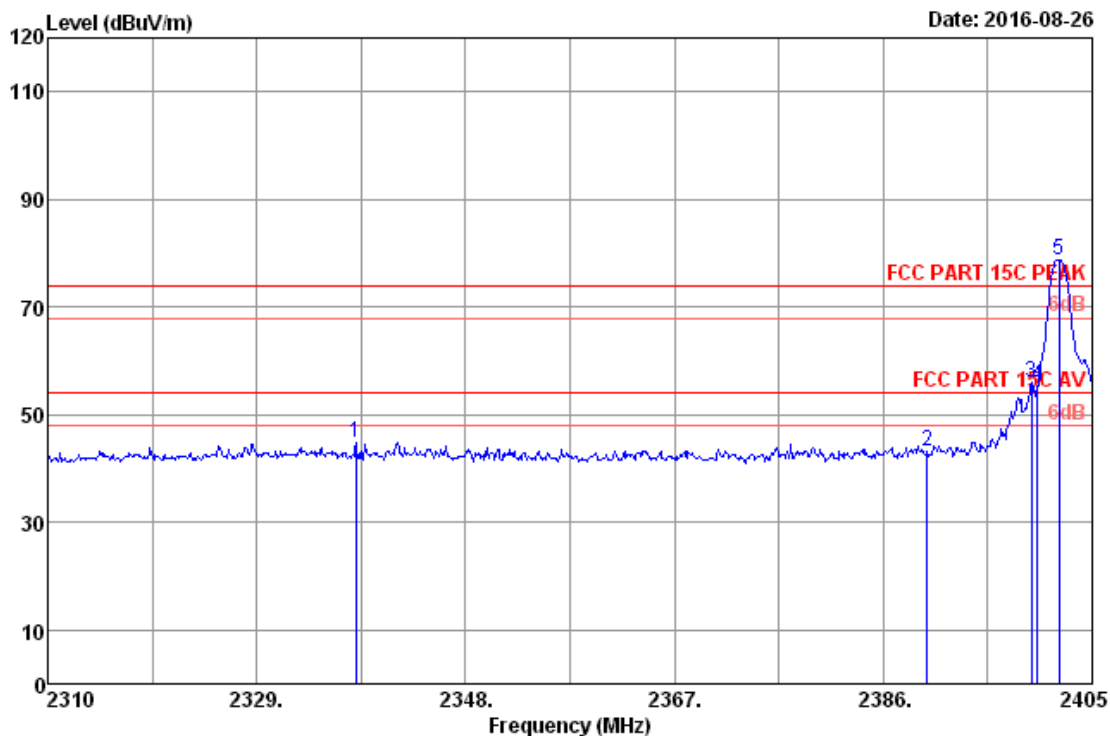

|              |                          |           |                |
|--------------|--------------------------|-----------|----------------|
| Site no.     | : RF Chamber             | Data no.  | : 31           |
| Dis. / Ant.  | : 3m 2015 3115-4877      | Ant. pol. | : VERTICAL     |
| Limit        | : FCC PART 15C PEAK      | Pre       | : 101.2kPa     |
| Env. / Ins.  | : 22.6*C/51.2%           | Engineer  | : Donjon_Huang |
| EUT          | : Mobile wall mount unit |           |                |
| Power rating | : DC 12V                 |           |                |
| Test Mode    | : 8-DPSK 2402MHz Tx Mode |           |                |
| M/N          | : JWM1A                  |           |                |

| No. | Freq. (MHz) | Ant. Factor (dB/m) | Cable Loss (dB) | Reading (dBuV) | AMP factor (dB) | Emission Level (dBuV/m) | Limits (dBuV/m) | Margin (dB) | Remark |
|-----|-------------|--------------------|-----------------|----------------|-----------------|-------------------------|-----------------|-------------|--------|
| 1   | 2338.03     | 28.21              | 8.27            | 44.81          | 36.39           | 44.90                   | 74.00           | 29.10       | Peak   |
| 2   | 2390.00     | 28.27              | 8.33            | 43.04          | 36.39           | 43.25                   | 74.00           | 30.75       | Peak   |
| 3   | 2399.49     | 28.28              | 8.34            | 55.66          | 36.39           | 55.89                   | 74.00           | 18.11       | Peak   |
| 4   | 2400.00     | 28.28              | 8.34            | 55.11          | 36.39           | 55.34                   | 74.00           | 18.66       | Peak   |
| 5   | 2401.96     | 28.28              | 8.34            | 78.50          | 36.39           | 78.73                   | 74.00           | -4.73       | Peak   |

Remarks: 1. Emission Level= Antenna Factor + Cable Loss + Reading - Amp Factor  
 2. The emission levels that are 20dB below the official limit are not reported.

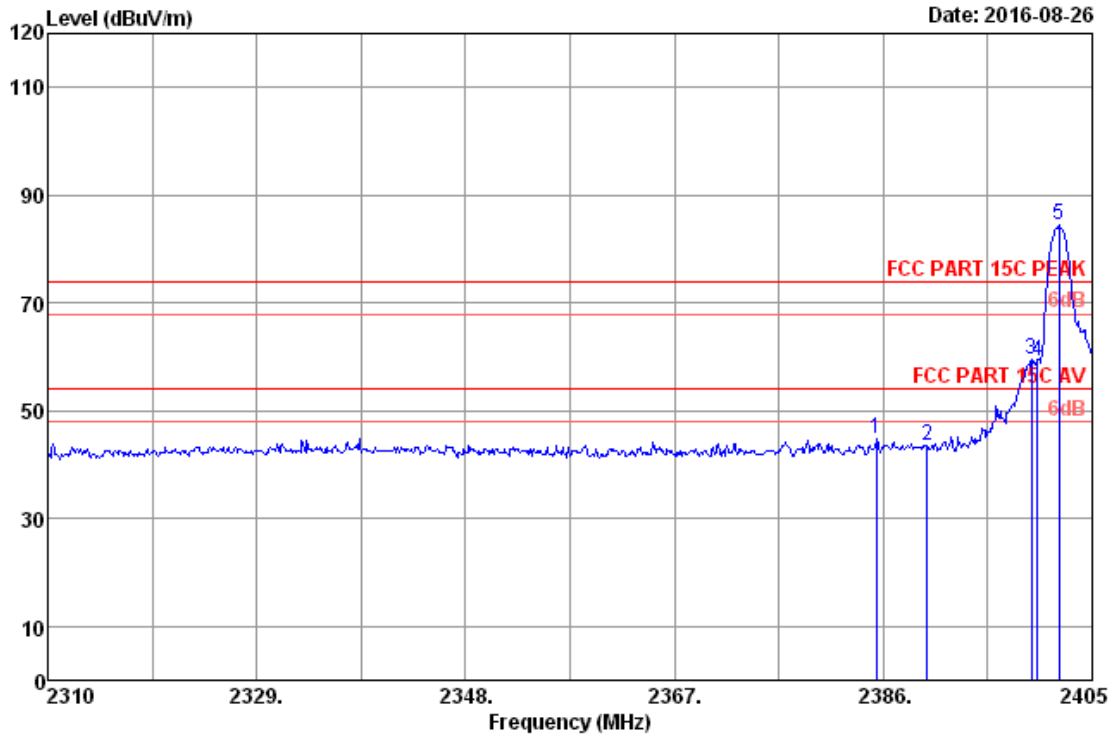

Site no. : RF Chamber  
 Dis. / Ant. : 3m 2015 3115-4877  
 Limit : FCC PART 15C PEAK  
 Env. / Ins. : 22.6°C/51.2%  
 EUT : Mobile wall mount unit  
 Power rating : DC 12V  
 Test Mode : 8-DPSK 2402MHz Tx Mode  
 M/N : JWM1A

Data no. : 32  
 Ant. pol. : HORIZONTAL  
 Pre : 101.2kPa  
 Engineer : Donjon\_Huang

| No. | Freq. (MHz) | Ant. Factor (dB/m) | Cable Loss (dB) | Reading (dBuV) | AMP factor (dB) | Emission Level (dBuV/m) | Limits (dBuV/m) | Margin (dB) | Remark |
|-----|-------------|--------------------|-----------------|----------------|-----------------|-------------------------|-----------------|-------------|--------|
| 1   | 2385.34     | 28.26              | 8.32            | 44.63          | 36.39           | 44.82                   | 74.00           | 29.18       | Peak   |
| 2   | 2390.00     | 28.27              | 8.33            | 43.17          | 36.39           | 43.38                   | 74.00           | 30.62       | Peak   |
| 3   | 2399.49     | 28.28              | 8.34            | 59.45          | 36.39           | 59.68                   | 74.00           | 14.32       | Peak   |
| 4   | 2400.00     | 28.28              | 8.34            | 58.93          | 36.39           | 59.16                   | 74.00           | 14.84       | Peak   |
| 5   | 2401.96     | 28.28              | 8.34            | 84.13          | 36.39           | 84.36                   | 74.00           | -10.36      | Peak   |

Remarks: 1. Emission Level= Antenna Factor + Cable Loss + Reading - Amp Factor  
 2. The emission levels that are 20dB below the official limit are not reported.

## 12.DEVIATION TO TEST SPECIFICATIONS

[NONE]