



FCC PART 15C TEST REPORT FOR CERTIFICATION
On Behalf of

Sounding Audio Industrial Ltd.

Heavy Duty radio with AM/FM/USB/Bluetooth

Model Number: JHD40BTBRP

Brand Name: BRP

FCC ID: OPDJHD40BTBRP

Prepared for : Sounding Audio Industrial Ltd.
Unit N, 7/F, Stage 2. Wah Fung Industrial Centre 33-39
Kwai Chung Road, Kwai Chung, Hong Kong

Prepared By : Audix Technology (Shenzhen) Co., Ltd.
No. 6, Ke Feng Rd., 52 Block,
Shenzhen Science & Industrial Park,
Nantou, Shenzhen, Guangdong, China

Tel: (0755) 26639496

Report Number : ACS-F16006

Date of Test : Dec.19~27, 2015

Date of Report : Jan.14, 2016

TABLE OF CONTENTS

| <u>Description</u> | <u>Page</u> |
|---|-------------|
| 1. SUMMARY OF STANDARDS AND RESULTS | 1-1 |
| 1.1. Description of Standards and Results..... | 1-1 |
| 2. GENERAL INFORMATION..... | 2-1 |
| 2.1. Description of Device (EUT) | 2-1 |
| 2.2. Test information | 2-2 |
| 2.3. Tested Supporting System Details | 2-2 |
| 2.4. Block Diagram of Test Setup..... | 2-2 |
| 2.5. Test Facility..... | 2-3 |
| 2.6. Measurement Uncertainty (95% confidence levels, k=2) | 2-3 |
| 3. POWER LINE CONDUCTED EMISSION TEST..... | 3-1 |
| 4. RADIATED EMISSION MEASUREMENT | 4-1 |
| 4.1. Test Equipment | 4-1 |
| 4.2. Block Diagram of Test Setup..... | 4-2 |
| 4.3. Radiated Emission Limit Standard: FCC 15.209 | 4-3 |
| 4.4. EUT Configuration on Test..... | 4-3 |
| 4.5. Operating Condition of EUT..... | 4-3 |
| 4.6. Test Procedure..... | 4-3 |
| 4.7. Radiated Emission Test Results | 4-4 |
| 5. CONDUCTED SPURIOUS EMISSIONS | 5-1 |
| 5.1. Test Equipment | 5-1 |
| 5.2. Limit..... | 5-1 |
| 5.3. Test Procedure..... | 5-1 |
| 5.4. Test result | 5-1 |
| 6. CARRIER FREQUENCY SEPARATION TEST | 6-1 |
| 6.1. Test Equipment | 6-1 |
| 6.2. Limit..... | 6-1 |
| 6.3. Test Results | 6-1 |
| 7. 20 DB BANDWIDTH TEST | 7-1 |
| 7.1. Test Equipment | 7-1 |
| 7.2. Limit..... | 7-1 |
| 7.3. Test Results | 7-1 |
| 8. NUMBER OF HOPPING FREQUENCY TEST | 8-1 |
| 8.1. Test Equipment | 8-1 |
| 8.2. Limit..... | 8-1 |
| 8.3. Test Results | 8-1 |
| 9. DWELL TIME..... | 9-1 |
| 9.1. Test Equipment | 9-1 |
| 9.2. Limit..... | 9-1 |
| 9.3. Test Results | 9-1 |
| 10. MAXIMUM PEAK OUTPUT POWER TEST..... | 10-1 |
| 10.1. Test Equipment | 10-1 |
| 10.2. Limit..... | 10-1 |
| 10.3. Test Procedure..... | 10-1 |
| 10.4. Test Results | 10-1 |

| | | |
|------------|---|-------------|
| 11. | BAND EDGE COMPLIANCE TEST | 11-1 |
| 11.1. | Test Equipment | 11-1 |
| 11.2. | Limit..... | 11-1 |
| 11.3. | Test Produce | 11-1 |
| 11.4. | Test Results | 11-1 |
| 12. | DEVIATION TO TEST SPECIFICATIONS | 12-1 |
| 13. | PHOTOGRAPH OF TEST..... | 13-1 |
| 13.1. | Photos of Radiated Emission Test..... | 13-1 |
| 14. | PHOTOS OF THE EUT | 14-1 |

TEST REPORT CERTIFICATION

Applicant : Sounding Audio Industrial Ltd.
 Manufacturer : AR Electronics Co., Ltd.
 EUT Description : Heavy Duty radio with AM/FM/USB/Bluetooth
 FCC ID : OPDJHD40BTBRP
 (A) MODEL NO. : JHD40BTBRP
 (B) Brand Name : BRP
 (C) Serial No. : N/A
 (D) POWER SUPPLY : DC 12V
 (E) TEST VOLTAGE : DC 12V

Tested for comply with:
 FCC Rules and Regulations Part 15 Subpart C: 2014
 Test procedure used:
 ANSI C63.10: 2009

The device described above is tested by AUDIX TECHNOLOGY (SHENZHEN) CO., LTD. to confirm comply with all the FCC Part 15 Subpart C requirements. The test results are contained in this test report and AUDIX TECHNOLOGY (SHENZHEN) CO., LTD. is assumed full responsibility for the accuracy and completeness of these tests. Also, this report shows that the Equipment Under Test (EUT) is to be technically compliant with the FCC and IC requirements. This report contains data that are not covered by the NVLAP accreditation.

This Report is made under FCC Part 2.1075. No modifications were required during testing to bring this product into compliance.

This report applies to above tested sample only. This report shall not be reproduced in part without written approval of AUDIX TECHNOLOGY (SHENZHEN) CO., LTD.

The report must not be used by the client to claim product certification, approval, or endorsement by NVLAP, NIST, or any agency of the federal government.

Date of Test : Dec.19~27, 2015 Report of date: Jan.14, 2016

Prepared by : Cindy Zhu Reviewed by : Sunny Lu
 Cindy Zhu / Assistant Sunny Lu / Assistant Manager

信華科技(深圳)有限公司
 Audix Technology (Shenzhen) Co., Ltd.
 EMC 部門報告專用章
 Stamp only for EMC Dept. Report
 Signature: David Jin
 David Jin / Manager

Approved & Authorized Signer : _____

1. SUMMARY OF STANDARDS AND RESULTS

1.1. Description of Standards and Results

The EUT have been tested according to the applicable standards as referenced below.

| EMISSION | | |
|------------------------------------|---|---------|
| Description of Test Item | Standard | Results |
| Power Line Conducted Emission Test | FCC Part 15: 15.207 ANSI C63.10 : 2009 | N/A |
| Radiated Emission Test | FCC Part 15: 15.209 FCC Part 15: 15.247(d) ANSI C63.10 : 2009 | PASS |
| Conducted Spurious Emissions | FCC Part 15: 15.247(a)(1) ANSI C63.10 : 2009 | PASS |
| Carrier Frequency Separation Test | FCC Part 15: 15.247(a)(1) ANSI C63.10 : 2009 | PASS |
| 20dB Bandwidth Test | FCC Part 15: 15.215 ANSI C63.10 : 2009 | PASS |
| Number Of Hopping Frequency Test | FCC Part 15: 15.247(a)(1)(iii) ANSI C63.10 : 2009 | PASS |
| Dwell Time Test | FCC Part 15: 15.247(a)(1)(iii) ANSI C63.10 : 2009 | PASS |
| Maximum Peak Output Power Test | FCC Part 15: 15.247(b)(1)\ ANSI C63.10 : 2009 | PASS |
| Band Edge Compliance Test | FCC Part 15: 15.247(d) ANSI C63.10 : 2009 | PASS |

2. GENERAL INFORMATION

2.1. Description of Device (EUT)

| | |
|-----------------------|--|
| EUT name | : Heavy Duty radio with AM/FM/USB/Bluetooth |
| Model Number | : JHD40BTBRP |
| Brand Name | : BRP |
| FCC ID | : OPDJHD40BTBRP |
| Radio | : Bluetooth V2.1 + EDR |
| Operation frequency | : 2402-2480MHz |
| Channel Number | : 79 channels |
| Modulation Technology | : GFSK, $\pi/4$ DQPSK, 8-DPSK |
| Antenna Type | : Integrated PCB Antenna, 3dBi PK Gain |
| Applicant | : Sounding Audio Industrial Ltd. Unit N, 7/F, Stage 2. Wah Fung Industrial Centre 33-39 Kwai Chung Road, Kwai Chung, Hong Kong |
| Manufacturer | : AR Electronics Co., Ltd. Sima District, Changping, China |
| Date of Test | : Dec.19~27, 2015 |
| Date of Receipt | : Dec.17, 2015 |
| Sample Type | : Prototype production |

2.2. Test information

A special test software was used to control EUT work in Continuous TX mode, and select test channel.

| Tested mode, channel, and data rate information | | | |
|---|------------------|--------------|-----------------|
| Mode | data rate (Mbps) | Channel | Frequency (MHz) |
| Tx Mode GFSK modulation | 1 | Low :CH 0 | 2402 |
| | 1 | Middle: CH39 | 2441 |
| | 1 | High: CH78 | 2480 |
| Tx Mode 8-DPSK modulation | 3 | Low :CH 0 | 2402 |
| | 3 | Middle: CH39 | 2441 |
| | 3 | High: CH78 | 2480 |

Note: $\pi/4$ DQPSK modulation is same type modulation with 8-DPSK, and according exploratory test, 8-DPSK will have worse emissions, so the final test were only performed with GFSK and 8-DPSK modulation.

2.3. Tested Supporting System Details

| No. | Description | ACS No. | Manufacturer | Model | Serial Number | Approved type |
|-----|-------------|-------------------------------------|--------------|-----------|---------------|---------------|
| 1 | Speaker #1 | N/A | SONY | SS-CMX700 | N/A | N/A |
| | | Cable: Shielded, Undetachable, 0.9m | | | | |
| 2 | Speaker #2 | N/A | SONY | SS-CEH45 | N/A | N/A |
| | | Cable: Shielded, Undetachable, 0.9m | | | | |
| 3 | Ipod | ACS-EMC-IP01 | APPLE | A1199 | YM706MLDVQ5 | N/A |

2.4. Block Diagram of Test Setup

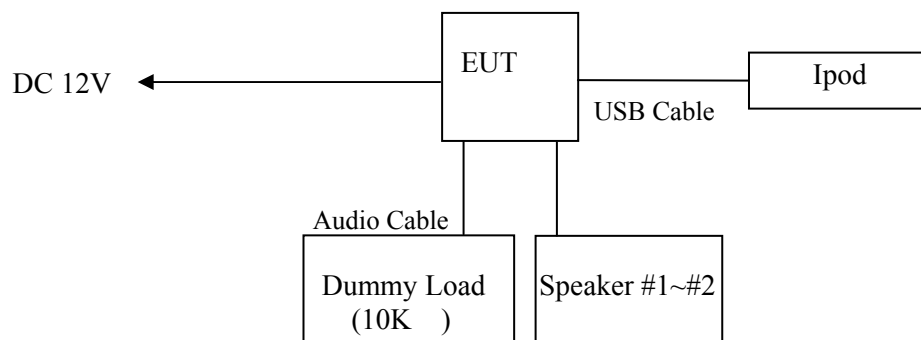

(EUT: Heavy Duty radio with AM/FM/USB/Bluetooth)

2.5. Test Facility

Site Description

Name of Firm : Audix Technology (Shenzhen) Co., Ltd.
 No. 6, Ke Feng Rd., 52 Block, Shenzhen
 Science & Industrial Park, Nantou, Shenzhen,
 Guangdong, China

3m Anechoic Chamber : Certificated by FCC, USA
 Registration Number: 90454
 Valid Date: Dec.30, 2017

3m & 10m Anechoic Chamber : Certificated by FCC, USA
 Registration Number: 794232
 Valid Date: Jul.12, 2016

EMC Lab. : Certificated by Industry Canada
 Registration Number: IC 5183A-1
 Valid Date: May.14, 2017

: Certificated by DAkkS, Germany
 Registration No: D-PL-12151-01-00
 Valid Date: Dec.15, 2016

: Accredited by NVLAP, USA
 NVLAP Code: 200372-0
 Valid Date: Mar.31, 2016

2.6. Measurement Uncertainty (95% confidence levels, k=2)

| Test Item | Uncertainty |
|--|------------------------------------|
| Uncertainty for Radiation Emission test in 3m chamber | 2.6 dB(30~200MHz, Polarization: H) |
| | 2.6 dB(30~200MHz, Polarization: V) |
| | 3.0 dB(200M~1GHz, Polarization: H) |
| | 2.8 dB(200M~1GHz, Polarization: V) |
| Uncertainty for Radiation Emission test in 3m chamber (1GHz-18GHz) | 6.3 dB (1~6GHz, Distance: 3m) |
| | 5.7 dB (6~18GHz, Distance: 3m) |
| Uncertainty for Radiated Spurious Emission test in RF chamber | 3.6 dB |
| Uncertainty for Conduction Spurious emission test | 2.0 dB |
| Uncertainty for Output power test | 0.8 dB |
| Uncertainty for Bandwidth test | 83 kHz |
| Uncertainty for DC power test | 0.1 % |
| Uncertainty for test site temperature and humidity | 0.6°C |
| | 3% |

3. POWER LINE CONDUCTED EMISSION TEST

According to Paragraph (c) of FCC Part 15 section 15.207, Tests to demonstrate compliance with the conducted limits are not required for devices which only employ battery power for operation and which do not operate from the AC power lines or contain provisions for operation while connected to the AC power lines.

4. RADIATED EMISSION MEASUREMENT

4.1. Test Equipment

Frequency rang: 30~1000MHz (In 3m Anechoic Chamber)

| Item | Equipment | Manufacturer | Model No. | Serial No. | Last Cal. | Cal. Interval |
|------|--------------------------|-----------------|---------------------|-----------------|-----------|---------------|
| 1. | 3#Chamber | AUDIX | N/A | N/A | Mar.28,15 | 1 Year |
| 2. | EMI Spectrum | Agilent | E4407B | MY41440292 | Apr.28,15 | 1 Year |
| 3. | Test Receiver | Rohde & Schwarz | ESVS10 | 834468/011 | Apr.28,15 | 1 Year |
| 4. | Amplifier | HP | 8447D | 2648A04738 | Apr.28,15 | 1 Year |
| 5. | Trilog-Broadband Antenna | SCHWARZBECK | VULB 9168 | 9168-493 | May.06,15 | 1 Year |
| 6. | RF Cable | MIYAZAKI | CFD400-N W(3.5M) | No.3 | Apr.28,15 | 1 Year |
| 7. | RF Cable | MIYAZAKI | CFD400-L W(22M) | No.7 | Apr.28,15 | 1 Year |
| 8. | Coaxial Switch | Anritsu | MP59B | 6201397222 | Apr.28,15 | 1 Year |
| 9. | Test Software | AUDIX | E3 | 6.2009-5-21a(n) | N/A | N/A |

4.1.1. For frequency range 1GHz~25GHz (In 3m Anechoic Chamber)

| Item | Equipment | Manufacturer | Model No. | Serial No. | Last Cal. | Cal. Interval |
|------|-------------------|--------------|-------------|-----------------|-----------|---------------|
| 1. | Spectrum Analyzer | Agilent | E4446A | US44300459 | Apr.28,15 | 1 Year |
| 2. | Horn Antenna | ETC | MCTD 1209 | DRH15F03007 | Feb.03,15 | 1 Year |
| 3. | Amplifier | Agilent | 8449B | 3008A02495 | Apr.28,15 | 1 Year |
| 4. | RF Cable | Hubersuhner | SUCOFLEX106 | 77977/6 | Apr.28,15 | 1 Year |
| 5. | Horn Antenna | ETS | 3116 | 00060088 | Nov.18.15 | 1 Year |
| 6. | Test Software | AUDIX | E3 | 6.2009-5-21a(n) | N/A | N/A |

page

4.2. Block Diagram of Test Setup

For frequency range 30MHz-1000MHz

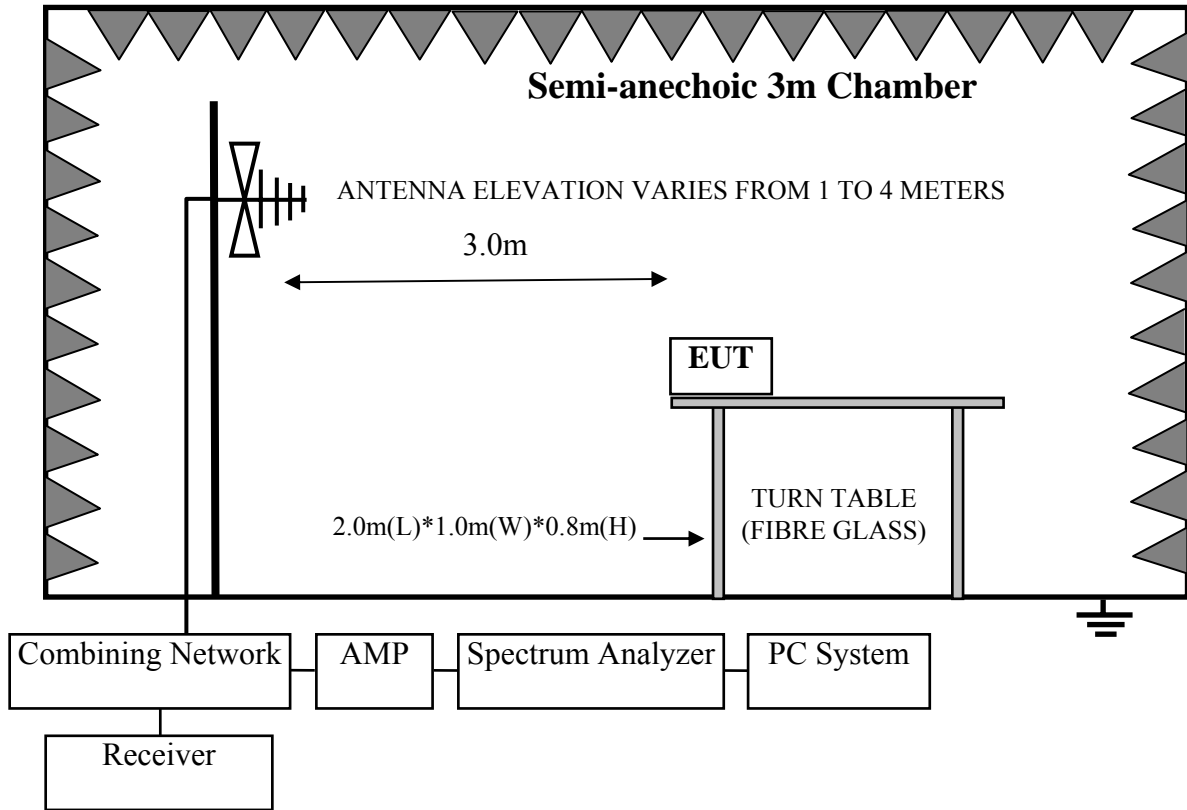

For frequency range 1GHz-25GHz

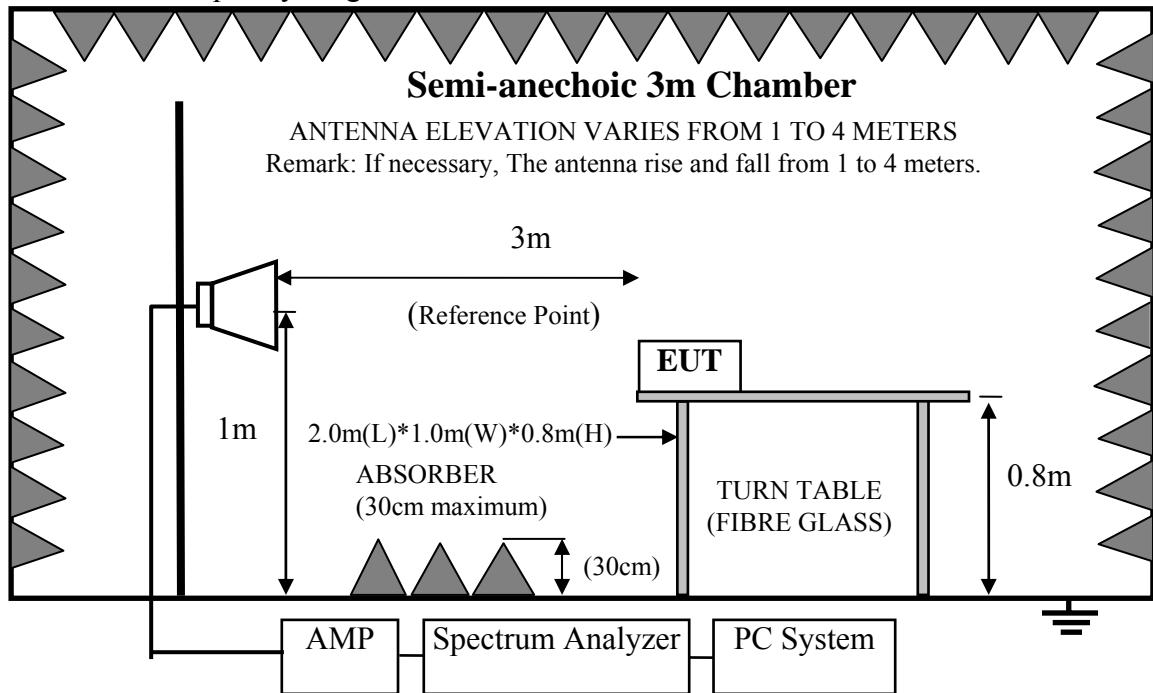

4.3. Radiated Emission Limit Standard: FCC 15.209

| FREQUENCY MHz | DISTANCE Meters | FIELD STRENGTHS LIMIT | |
|------------------|--------------------|---|----------|
| | | μV/m | dB(μV)/m |
| 30 ~ 88 | 3 | 100 | 40.0 |
| 88 ~ 216 | 3 | 150 | 43.5 |
| 216 ~ 960 | 3 | 200 | 46.0 |
| 960 ~ 1000 | 3 | 500 | 54.0 |
| Above 1000MHz | 3 | 74.0 dB(μV)/m (Peak) 54.0 dB(μV)/m (Average) | |

Remark : (1) Emission level $dB\mu V = 20 \log$ Emission level $\mu V/m$

- (2) The smaller limit shall apply at the cross point between two frequency bands.
- (3) Distance is the distance in meters between the measuring instrument, antenna and the closest point of any part of the device or system.
- (4) The emission limits shown in the above table are based on measurements employing a CISPR quasi-peak detector except for the frequency bands 9-90 kHz, 110-490 kHz and above 1000 MHz. Radiated emission limits in these three bands are based on measurements employing an average detector.

4.4.EUT Configuration on Test

The following equipment are installed on Power Line Conducted Emission Test to meet the commission requirement and operating regulations in a manner which tends to maximize its emission characteristics in a normal application.

4.4.1.Heavy Duty radio with AM/FM/USB/Bluetooth (EUT)

Model Number: JHD40BTBRP

Serial Number: N/A

4.4.2.Support Equipment: As Tested Supporting System Details, in Section 2.2.

4.5.Operating Condition of EUT

4.5.1.Setup the EUT and simulator as shown as Section 4.2.

4.5.2.Turn on the power of all equipments.

4.5.3.Let EUT work in Tx mode.

4.6.Test Procedure

EUT and its simulators are placed on a turn table, which is 0.8 meter high above ground for frequency 30MHz~1000MHz, 1.5 meter high above ground for frequency above 1GHz and put the absorbing with 2.4m(L)*2.4m(W)*0.3m(H) on the ground . The turn table can rotate 360 degrees to determine the position of the maximum emission level. Power on the EUT and let it working in test mode, then test it.EUT is set 3 meters away from the receiving antenna, which is mounted on a antenna tower. The antenna can be moved up and down between 1 meter and 4 meters to find out the maximum emission level. Broadband antenna (calibrated bilog antenna) is used as receiving antenna for frequency 30MHz~1000MHz, and the Horn antenna is used as receiving antenna for frequency above 1GHz. Both horizontal and vertical polarization of the antenna is set on Test. In order to find the maximum emission levels, all of the interface cables must be manipulated according to ANSI C63.10-2013 on radiated emission Test.

page

This test was performed with EUT in X, Y, Z position, and the worse case was found when EUT in X position as the test photo indicated.

The bandwidth of the EMI test receiver (R&S ESVS10) is set at 120kHz for frequency range from 30MHz to 1000 MHz.

The bandwidth of the Spectrum's RBW is set at 1MHz and VBW is set at 3MHz for peak emissions measurement above 1GHz

This device is pulse Modulated, a duty cycle factor was used to calculated average level based measured peak level.

The frequency range from 30MHz to 10th harmonic (25GHz) are checked. and no any emissions were found from 18GHz to 25 GHz, So the radiated emissions from 18GHz to 25GHz were not record.

4.7. Radiated Emission Test Results

PASS.

All the emissions from 30MHz to 25GHz were comply with the 15.209 Limit.

Note: The duty cycle factor for calculate average level is -30.565 dB, and average limit is 20dB below peak limit, so if peak measured level comply with average limit, the average level was deemed to comply with average limit.

$$\text{Duty cycle factor} = 20 \log \left(\frac{\text{Dwell time}}{100\text{ms}} \right) = -30.565$$

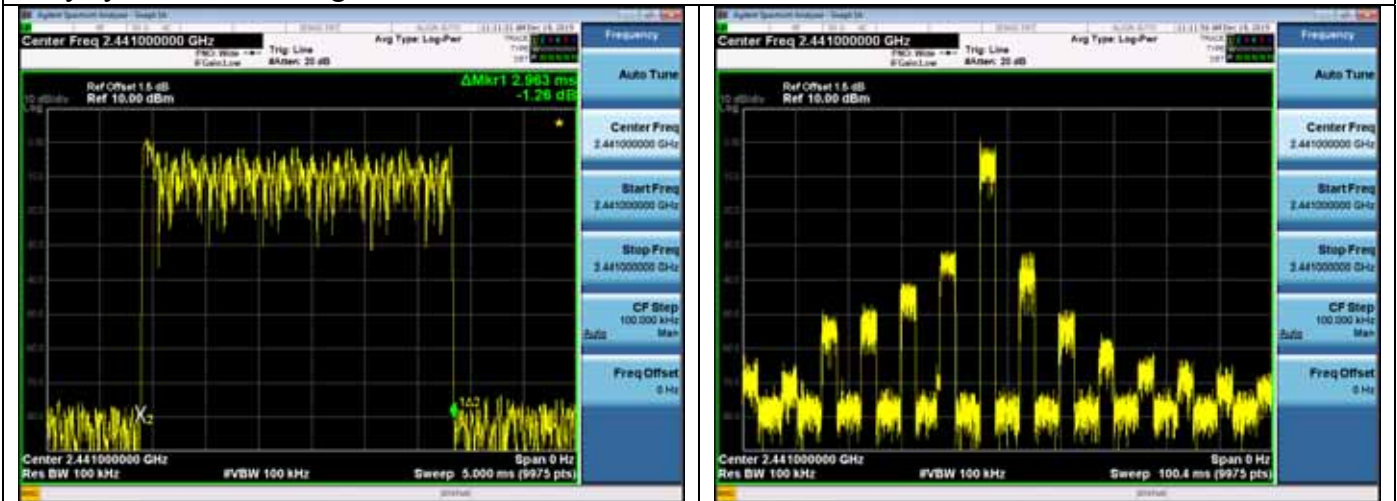

page

Frequency: 30MHz~1GHz

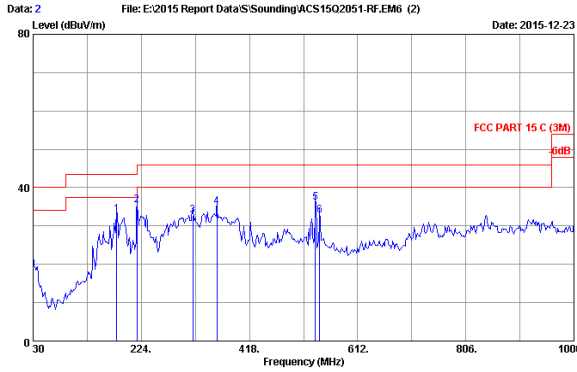

Site no. : 3m Chamber Data no. : 2
 Dis. / Ant. : 3m 2015 CBL6112D 35375 Ant. pol. : HORIZONTAL
 Limit : FCC PART 15 C (3M)
 Env. / Ins. : 22.1°C/50% Engineer : Donjon
 EUT : Heavy Duty radio with AM/FM/USB/Bluetooth
 Power rating : DC 12V
 Test Mode : Tx Mode
 M/N : JHD40BTBRP

| No. | Freq. (MHz) | Ant. Factor (dB/m) | Cable Loss (dB) | Reading (dBuV) | Emission Level (dBuV/m) | Limits (dBuV/m) | Margin (dB) | Remark |
|-----|-------------|--------------------|-----------------|----------------|-------------------------|-----------------|-------------|--------|
| 1 | 180.350 | 10.02 | 1.43 | 21.60 | 33.05 | 43.50 | 10.45 | QP |
| 2 | 216.240 | 10.81 | 1.57 | 23.02 | 35.40 | 46.00 | 10.60 | QP |
| 3 | 316.150 | 14.50 | 1.94 | 16.33 | 32.77 | 46.00 | 13.23 | QP |
| 4 | 359.800 | 15.99 | 2.07 | 17.03 | 35.09 | 46.00 | 10.91 | QP |
| 5 | 536.340 | 18.55 | 2.61 | 14.87 | 36.03 | 46.00 | 9.97 | QP |
| 6 | 544.100 | 18.70 | 2.63 | 11.50 | 32.83 | 46.00 | 13.17 | QP |

Remarks: 1. Emission Level= Antenna Factor + Cable Loss + Reading.
 2. The emission levels that are 20dB below the official limit are not reported.

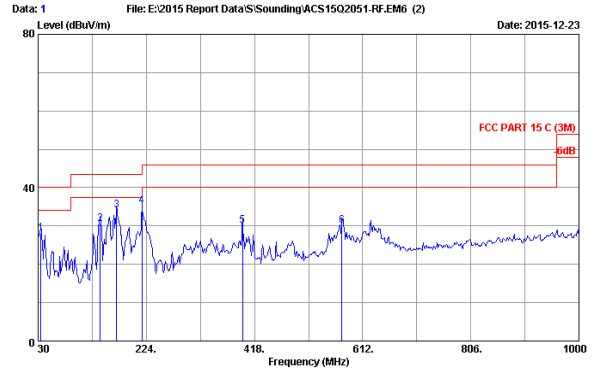

Site no. : 3m Chamber Data no. : 1
 Dis. / Ant. : 3m 2015 CBL6112D 35375 Ant. pol. : VERTICAL
 Limit : FCC PART 15 C (3M)
 Env. / Ins. : 22.1°C/50% Engineer : Donjon
 EUT : Heavy Duty radio with AM/FM/USB/Bluetooth
 Power rating : DC 12V
 Test Mode : Tx Mode
 M/N : JHD40BTBRP

| No. | Freq. (MHz) | Ant. Factor (dB/m) | Cable Loss (dB) | Reading (dBuV) | Emission Level (dBuV/m) | Limits (dBuV/m) | Margin (dB) | Remark |
|-----|-------------|--------------------|-----------------|----------------|-------------------------|-----------------|-------------|--------|
| 1 | 34.850 | 17.15 | 0.61 | 10.27 | 28.03 | 40.00 | 11.97 | QP |
| 2 | 141.550 | 12.02 | 1.27 | 17.16 | 30.45 | 43.50 | 13.05 | QP |
| 3 | 170.650 | 10.27 | 1.38 | 22.54 | 34.19 | 43.50 | 9.31 | QP |
| 4 | 216.240 | 10.81 | 1.57 | 22.73 | 35.11 | 46.00 | 10.89 | QP |
| 5 | 396.660 | 16.78 | 2.20 | 11.14 | 30.12 | 46.00 | 15.88 | QP |
| 6 | 575.140 | 19.18 | 2.70 | 8.29 | 30.17 | 46.00 | 15.83 | QP |

Remarks: 1. Emission Level= Antenna Factor + Cable Loss + Reading.
 2. The emission levels that are 20dB below the official limit are not reported.

page

Frequency: 1GHz~18GHz

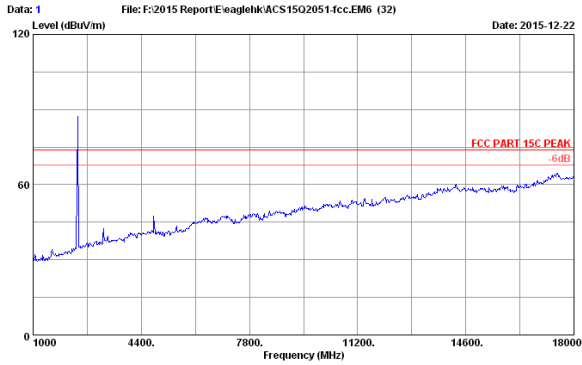

Site no. : 3m Chamber Data no. : 1
 Dis. / Ant. : 3m 2015 MCTD1209 3007 Ant. pol. : VERTICAL
 Limit : FCC PART 15C PEAK
 Env. / Ins. : 22.5°C/51.6%
 Engineer : Donjon Huang
 EUT : Heavy Duty radio with AM/FM/USB/Bluetooth
 Power rating : DC 12V
 Test Mode : GFSK 2402MHz TX MODE
 M/N : JHD40BTBRP

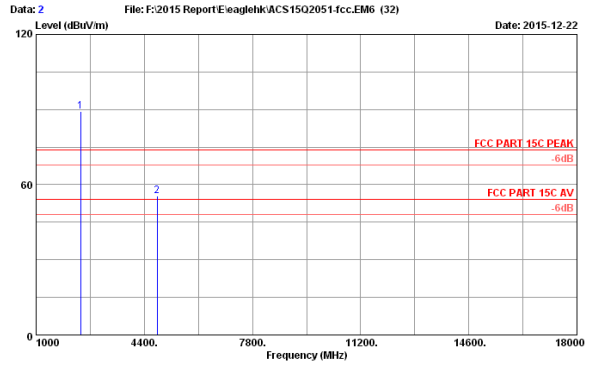

Site no. : 3m Chamber Data no. : 2
 Dis. / Ant. : 3m 2015 MCTD1209 3007 Ant. pol. : VERTICAL
 Limit : FCC PART 15C PEAK
 Env. / Ins. : 22.5°C/51.6%
 Engineer : Donjon Huang
 EUT : Heavy Duty radio with AM/FM/USB/Bluetooth
 Power rating : DC 12V
 Test Mode : GFSK 2402MHz TX MODE
 M/N : JHD40BTBRP

| No. | Freq. (MHz) | Ant. Factor (dB/m) | Cable Loss (dB) | AMP factor (dB) | Reading (dBuV) | Emission Level (dBuV/m) | Limits (dBuV/m) | Margin (dB) | Remark |
|-----|-------------|--------------------|-----------------|-----------------|----------------|-------------------------|-----------------|-------------|--------|
| 1 | 2402.000 | 27.80 | 7.32 | 36.62 | 90.62 | 89.12 | 74.00 | -15.12 | Peak |
| 2 | 4804.000 | 32.30 | 9.46 | 35.54 | 49.29 | 55.51 | 74.00 | 18.49 | Peak |

Remarks: 1. Emission Level= Antenna Factor + Cable Loss + Reading - Amp Factor
 2. The emission levels that are 20dB below the official limit are not reported.

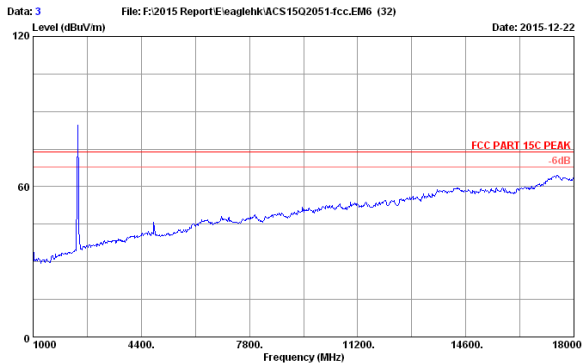

Site no. : 3m Chamber Data no. : 3
 Dis. / Ant. : 3m 2015 MCTD1209 3007 Ant. pol. : HORIZONTAL
 Limit : FCC PART 15C PEAK
 Env. / Ins. : 22.5°C/51.6%
 Engineer : Donjon Huang
 EUT : Heavy Duty radio with AM/FM/USB/Bluetooth
 Power rating : DC 12V
 Test Mode : GFSK 2402MHz TX MODE
 M/N : JHD40BTBRP

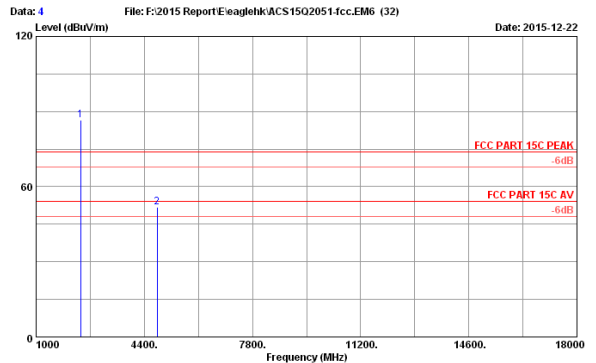

Site no. : 3m Chamber Data no. : 4
 Dis. / Ant. : 3m 2015 MCTD1209 3007 Ant. pol. : HORIZONTAL
 Limit : FCC PART 15C PEAK
 Env. / Ins. : 22.5°C/51.6%
 Engineer : Donjon Huang
 EUT : Heavy Duty radio with AM/FM/USB/Bluetooth
 Power rating : DC 12V
 Test Mode : GFSK 2402MHz TX MODE
 M/N : JHD40BTBRP

| No. | Freq. (MHz) | Ant. Factor (dB/m) | Cable Loss (dB) | AMP factor (dB) | Reading (dBuV) | Emission Level (dBuV/m) | Limits (dBuV/m) | Margin (dB) | Remark |
|-----|-------------|--------------------|-----------------|-----------------|----------------|-------------------------|-----------------|-------------|--------|
| 1 | 2402.000 | 27.80 | 7.32 | 36.62 | 87.96 | 86.46 | 74.00 | -12.46 | Peak |
| 2 | 4804.000 | 32.30 | 9.46 | 35.54 | 45.62 | 51.84 | 74.00 | 22.16 | Peak |

Remarks: 1. Emission Level= Antenna Factor + Cable Loss + Reading - Amp Factor
 2. The emission levels that are 20dB below the official limit are not reported.

page

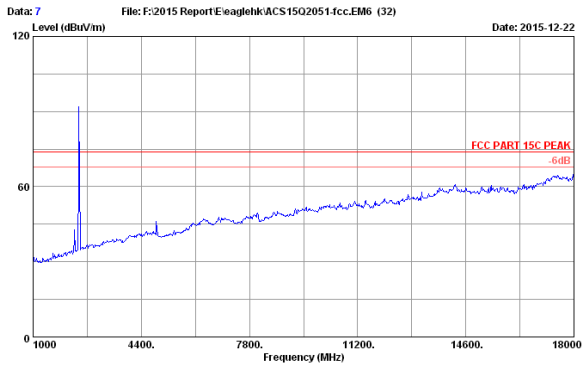

Site no. : 3m Chamber Data no. : 7
 Dis. / Ant. : 3m 2015 MCTD1209 3007 Ant. pol. : VERTICAL
 Limit : FCC PART 15C PEAK
 Env. / Ins. : 22.5°C/51.6%
 Engineer : Donjon_Huang
 EUT : Heavy Duty radio with AM/FM/USB/Bluetooth
 Power rating : DC 12V
 Test Mode : GFSK 2441MHz TX MODE
 M/N : JHD40BTBRP

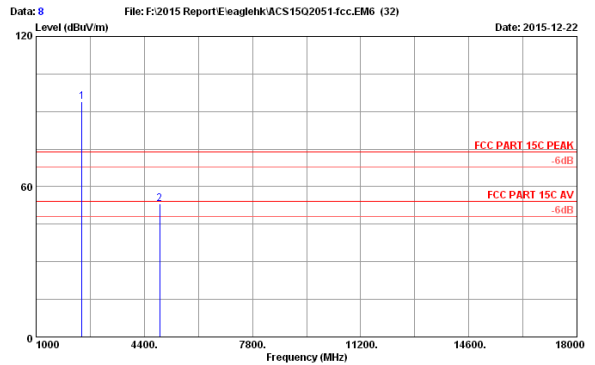

Site no. : 3m Chamber Data no. : 8
 Dis. / Ant. : 3m 2015 MCTD1209 3007 Ant. pol. : VERTICAL
 Limit : FCC PART 15C PEAK
 Env. / Ins. : 22.5°C/51.6%
 Engineer : Donjon_Huang
 EUT : Heavy Duty radio with AM/FM/USB/Bluetooth
 Power rating : DC 12V
 Test Mode : GFSK 2441MHz TX MODE
 M/N : JHD40BTBRP

| No. | Freq. (MHz) | Ant. Factor (dB/m) | Cable Loss (dB) | AMP factor (dB) | Reading (dBuV) | Emission Level (dBuV/m) | Limits (dBuV/m) | Margin (dB) | Remark |
|-----|-------------|--------------------|-----------------|-----------------|----------------|-------------------------|-----------------|-------------|--------|
| 1 | 2441.000 | 27.88 | 7.39 | 36.60 | 95.31 | 93.98 | 74.00 | -19.98 | Peak |
| 2 | 4882.000 | 32.22 | 9.49 | 35.51 | 46.89 | 53.09 | 74.00 | 20.91 | Peak |

Remarks: 1. Emission Level= Antenna Factor + Cable Loss + Reading - Amp Factor
 2. The emission levels that are 20dB below the official limit are not reported.

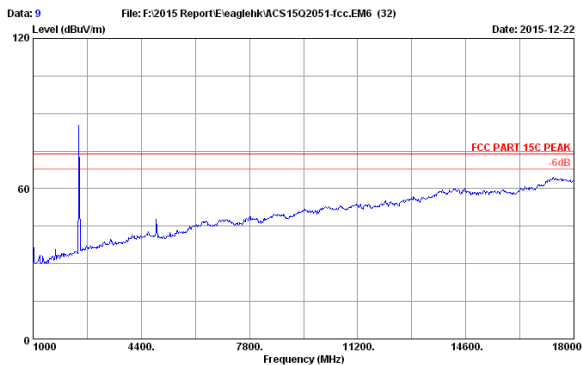

Site no. : 3m Chamber Data no. : 9
 Dis. / Ant. : 3m 2015 MCTD1209 3007 Ant. pol. : HORIZONTAL
 Limit : FCC PART 15C PEAK
 Env. / Ins. : 22.5°C/51.6%
 Engineer : Donjon_Huang
 EUT : Heavy Duty radio with AM/FM/USB/Bluetooth
 Power rating : DC 12V
 Test Mode : GFSK 2441MHz TX MODE
 M/N : JHD40BTBRP



Site no. : 3m Chamber Data no. : 10
 Dis. / Ant. : 3m 2015 MCTD1209 3007 Ant. pol. : HORIZONTAL
 Limit : FCC PART 15C PEAK
 Env. / Ins. : 22.5°C/51.6%
 Engineer : Donjon_Huang
 EUT : Heavy Duty radio with AM/FM/USB/Bluetooth
 Power rating : DC 12V
 Test Mode : GFSK 2441MHz TX MODE
 M/N : JHD40BTBRP

| No. | Freq. (MHz) | Ant. Factor (dB/m) | Cable Loss (dB) | AMP factor (dB) | Reading (dBuV) | Emission Level (dBuV/m) | Limits (dBuV/m) | Margin (dB) | Remark |
|-----|-------------|--------------------|-----------------|-----------------|----------------|-------------------------|-----------------|-------------|--------|
| 1 | 2441.000 | 27.88 | 7.39 | 36.60 | 89.72 | 88.39 | 74.00 | -14.39 | Peak |
| 2 | 4882.000 | 32.22 | 9.49 | 35.51 | 45.69 | 51.89 | 74.00 | 22.11 | Peak |

Remarks: 1. Emission Level= Antenna Factor + Cable Loss + Reading - Amp Factor
 2. The emission levels that are 20dB below the official limit are not reported.

page

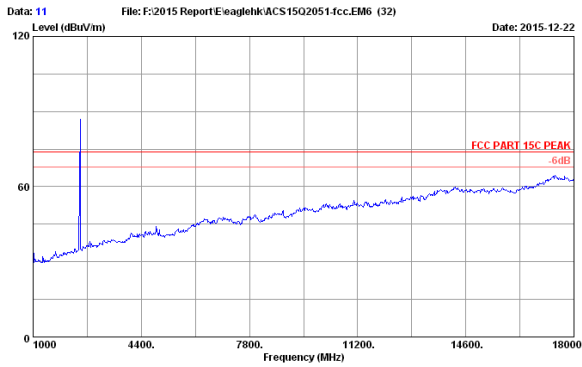

Site no. : 3m Chamber Data no. : 11
 Dis. / Ant. : 3m 2015 MCTD1209 3007 Ant. pol. : HORIZONTAL
 Limit : FCC PART 15C PEAK
 Env. / Ins. : 22.5°C/51.6%
 Engineer : Donjon_Huang
 EUT : Heavy Duty radio with AM/FM/USB/Bluetooth
 Power rating : DC 12V
 Test Mode : GFSK 2480MHz TX MODE
 M/N : JHD40BTBRP

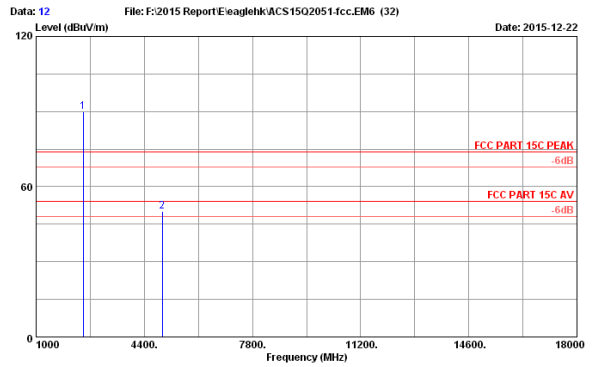

Site no. : 3m Chamber Data no. : 12
 Dis. / Ant. : 3m 2015 MCTD1209 3007 Ant. pol. : HORIZONTAL
 Limit : FCC PART 15C PEAK
 Env. / Ins. : 22.5°C/51.6%
 Engineer : Donjon_Huang
 EUT : Heavy Duty radio with AM/FM/USB/Bluetooth
 Power rating : DC 12V
 Test Mode : GFSK 2480MHz TX MODE
 M/N : JHD40BTBRP

| No. | Freq. (MHz) | Ant. Factor (dB/m) | Cable Loss (dB) | AMP factor (dB) | Reading (dBuV) | Emission Level (dBuV/m) | Limits (dBuV/m) | Margin (dB) | Remark |
|-----|-------------|--------------------|-----------------|-----------------|----------------|-------------------------|-----------------|-------------|--------|
| 1 | 2480.000 | 27.96 | 7.47 | 36.59 | 91.12 | 89.96 | 74.00 | -15.96 | Peak |
| 2 | 4960.000 | 32.14 | 9.52 | 35.47 | 43.95 | 50.14 | 74.00 | 23.86 | Peak |

Remarks: 1. Emission Level= Antenna Factor + Cable Loss + Reading - Amp Factor
 2. The emission levels that are 20dB below the official limit are not reported.

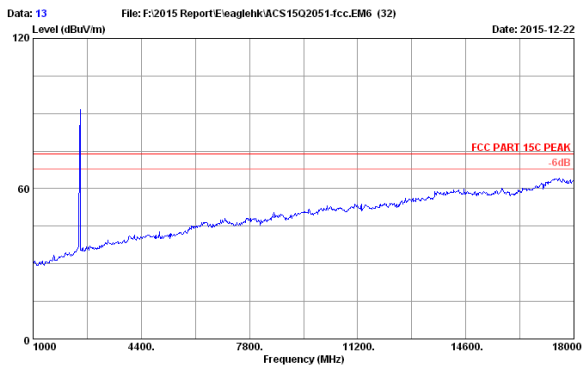

Site no. : 3m Chamber Data no. : 13
 Dis. / Ant. : 3m 2015 MCTD1209 3007 Ant. pol. : VERTICAL
 Limit : FCC PART 15C PEAK
 Env. / Ins. : 22.5°C/51.6%
 Engineer : Donjon_Huang
 EUT : Heavy Duty radio with AM/FM/USB/Bluetooth
 Power rating : DC 12V
 Test Mode : GFSK 2480MHz TX MODE
 M/N : JHD40BTBRP



Site no. : 3m Chamber Data no. : 14
 Dis. / Ant. : 3m 2015 MCTD1209 3007 Ant. pol. : VERTICAL
 Limit : FCC PART 15C PEAK
 Env. / Ins. : 22.5°C/51.6%
 Engineer : Donjon_Huang
 EUT : Heavy Duty radio with AM/FM/USB/Bluetooth
 Power rating : DC 12V
 Test Mode : GFSK 2480MHz TX MODE
 M/N : JHD40BTBRP

| No. | Freq. (MHz) | Ant. Factor (dB/m) | Cable Loss (dB) | AMP factor (dB) | Reading (dBuV) | Emission Level (dBuV/m) | Limits (dBuV/m) | Margin (dB) | Remark |
|-----|-------------|--------------------|-----------------|-----------------|----------------|-------------------------|-----------------|-------------|--------|
| 1 | 2479.000 | 27.96 | 7.47 | 36.59 | 93.76 | 92.60 | 74.00 | -18.60 | Peak |
| 2 | 4960.000 | 32.14 | 9.52 | 35.47 | 43.43 | 49.62 | 74.00 | 24.38 | Peak |

Remarks: 1. Emission Level= Antenna Factor + Cable Loss + Reading - Amp Factor
 2. The emission levels that are 20dB below the official limit are not reported.

page

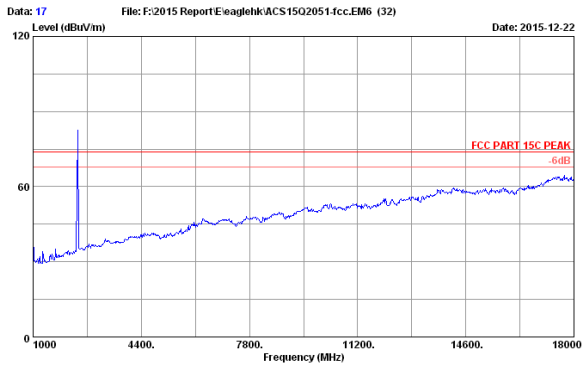

Site no. : 3m Chamber Data no. : 17
 Dis. / Ant. : 3m 2015 MCTD1209 3007 Ant. pol. : HORIZONTAL
 Limit : FCC PART 15C PEAK
 Env. / Ins. : 22.5°C/51.6%
 Engineer : Donjon_Huang
 EUT : Heavy Duty radio with AM/FM/USB/Bluetooth
 Power rating : DC 12V
 Test Mode : SPSK 2402MHz TX MODE
 M/N : JHD40BTBRP

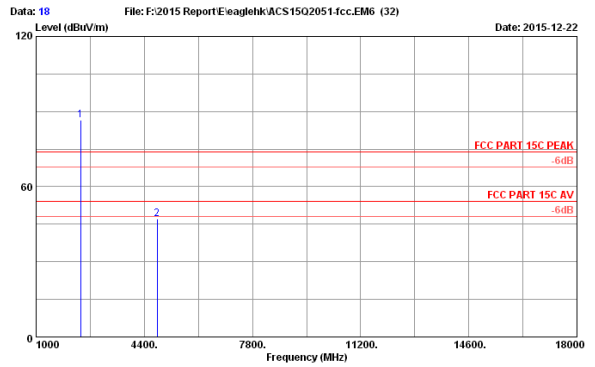

Site no. : 3m Chamber Data no. : 18
 Dis. / Ant. : 3m 2015 MCTD1209 3007 Ant. pol. : HORIZONTAL
 Limit : FCC PART 15C PEAK
 Env. / Ins. : 22.5°C/51.6%
 Engineer : Donjon_Huang
 EUT : Heavy Duty radio with AM/FM/USB/Bluetooth
 Power rating : DC 12V
 Test Mode : SPSK 2402MHz TX MODE
 M/N : JHD40BTBRP

| No. | Freq. (MHz) | Ant. Factor (dB/m) | Cable Loss (dB) | AMP factor (dB) | Reading (dBuV) | Emission Level (dBuV/m) | Limits (dBuV/m) | Margin (dB) | Remark |
|-----|-------------|--------------------|-----------------|-----------------|----------------|-------------------------|-----------------|-------------|--------|
| 1 | 2394.000 | 27.79 | 7.32 | 36.62 | 87.98 | 86.47 | 74.00 | -12.47 | Peak |
| 2 | 4804.000 | 32.30 | 9.46 | 35.54 | 41.01 | 47.23 | 74.00 | 26.77 | Peak |

Remarks: 1. Emission Level= Antenna Factor + Cable Loss + Reading - Amp Factor
 2. The emission levels that are 20dB below the official limit are not reported.

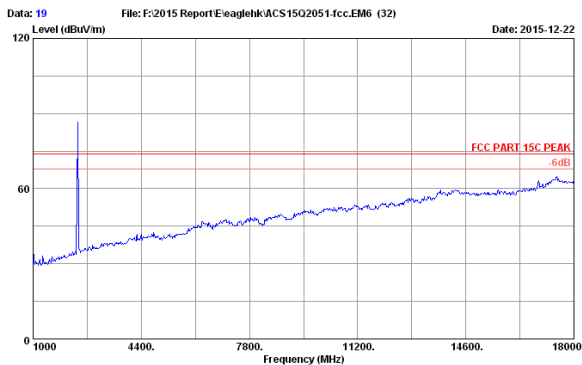

Site no. : 3m Chamber Data no. : 19
 Dis. / Ant. : 3m 2015 MCTD1209 3007 Ant. pol. : VERTICAL
 Limit : FCC PART 15C PEAK
 Env. / Ins. : 22.5°C/51.6%
 Engineer : Donjon_Huang
 EUT : Heavy Duty radio with AM/FM/USB/Bluetooth
 Power rating : DC 12V
 Test Mode : SPSK 2402MHz TX MODE
 M/N : JHD40BTBRP



Site no. : 3m Chamber Data no. : 20
 Dis. / Ant. : 3m 2015 MCTD1209 3007 Ant. pol. : VERTICAL
 Limit : FCC PART 15C PEAK
 Env. / Ins. : 22.5°C/51.6%
 Engineer : Donjon_Huang
 EUT : Heavy Duty radio with AM/FM/USB/Bluetooth
 Power rating : DC 12V
 Test Mode : SPSK 2402MHz TX MODE
 M/N : JHD40BTBRP

| No. | Freq. (MHz) | Ant. Factor (dB/m) | Cable Loss (dB) | AMP factor (dB) | Reading (dBuV) | Emission Level (dBuV/m) | Limits (dBuV/m) | Margin (dB) | Remark |
|-----|-------------|--------------------|-----------------|-----------------|----------------|-------------------------|-----------------|-------------|--------|
| 1 | 2394.000 | 27.79 | 7.32 | 36.62 | 88.06 | 86.55 | 74.00 | -12.55 | Peak |
| 2 | 4804.000 | 32.30 | 9.46 | 35.54 | 41.25 | 47.47 | 74.00 | 26.53 | Peak |

Remarks: 1. Emission Level= Antenna Factor + Cable Loss + Reading - Amp Factor
 2. The emission levels that are 20dB below the official limit are not reported.

page

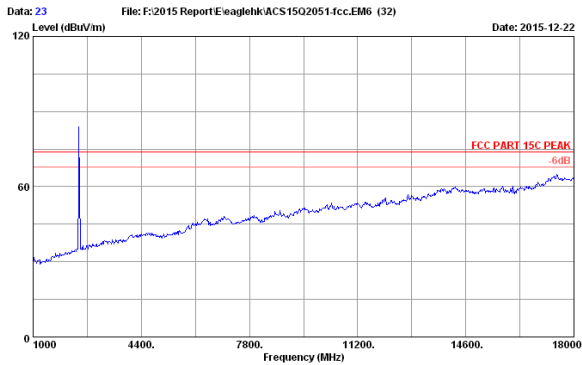

Site no. : 3m Chamber Data no. : 23
 Dis. / Ant. : 3m 2015 MCTD1209 3007 Ant. pol. : HORIZONTAL
 Limit : FCC PART 15C PEAK
 Env. / Ins. : 22.5°C/51.6%
 Engineer : Donjon_Huang
 EUT : Heavy Duty radio with AM/FM/USB/Bluetooth
 Power rating : DC 12V
 Test Mode : SPSK 2441MHz TX MODE
 M/N : JHD40BTBRP

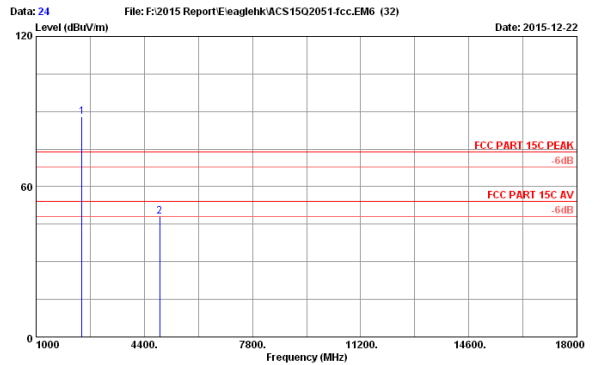

Site no. : 3m Chamber Data no. : 24
 Dis. / Ant. : 3m 2015 MCTD1209 3007 Ant. pol. : HORIZONTAL
 Limit : FCC PART 15C PEAK
 Env. / Ins. : 22.5°C/51.6%
 Engineer : Donjon_Huang
 EUT : Heavy Duty radio with AM/FM/USB/Bluetooth
 Power rating : DC 12V
 Test Mode : SPSK 2441MHz TX MODE
 M/N : JHD40BTBRP

| No. | Freq. (MHz) | Ant. Factor (dB/m) | Cable Loss (dB) | AMP factor (dB) | Reading (dBuV) | Emission Level (dBuV/m) | Limits (dBuV/m) | Margin (dB) | Remark |
|-----|-------------|--------------------|-----------------|-----------------|----------------|-------------------------|-----------------|-------------|--------|
| 1 | 2445.000 | 27.89 | 7.39 | 36.60 | 89.21 | 87.89 | 74.00 | -13.89 | Peak |
| 2 | 4892.000 | 32.22 | 9.49 | 35.51 | 41.89 | 48.09 | 74.00 | 25.91 | Peak |

Remarks: 1. Emission Level= Antenna Factor + Cable Loss + Reading - Amp Factor
 2. The emission levels that are 20dB below the official limit are not reported.

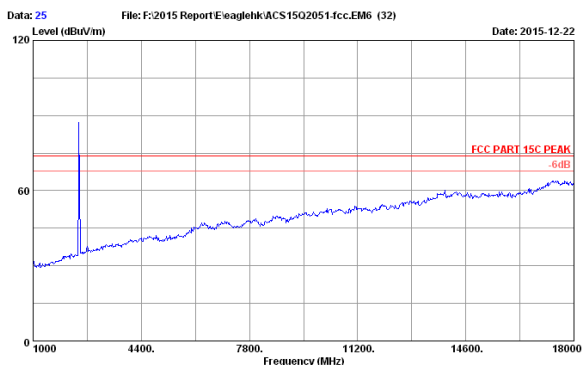

Site no. : 3m Chamber Data no. : 25
 Dis. / Ant. : 3m 2015 MCTD1209 3007 Ant. pol. : VERTICAL
 Limit : FCC PART 15C PEAK
 Env. / Ins. : 22.5°C/51.6%
 Engineer : Donjon_Huang
 EUT : Heavy Duty radio with AM/FM/USB/Bluetooth
 Power rating : DC 12V
 Test Mode : SPSK 2441MHz TX MODE
 M/N : JHD40BTBRP

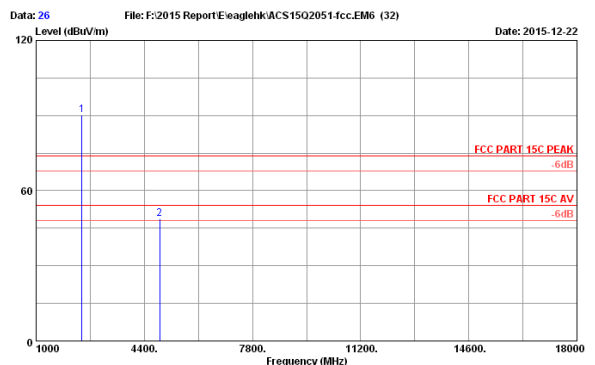

Site no. : 3m Chamber Data no. : 26
 Dis. / Ant. : 3m 2015 MCTD1209 3007 Ant. pol. : VERTICAL
 Limit : FCC PART 15C PEAK
 Env. / Ins. : 22.5°C/51.6%
 Engineer : Donjon_Huang
 EUT : Heavy Duty radio with AM/FM/USB/Bluetooth
 Power rating : DC 12V
 Test Mode : SPSK 2441MHz TX MODE
 M/N : JHD40BTBRP

| No. | Freq. (MHz) | Ant. Factor (dB/m) | Cable Loss (dB) | AMP factor (dB) | Reading (dBuV) | Emission Level (dBuV/m) | Limits (dBuV/m) | Margin (dB) | Remark |
|-----|-------------|--------------------|-----------------|-----------------|----------------|-------------------------|-----------------|-------------|--------|
| 1 | 2445.000 | 27.89 | 7.39 | 36.60 | 91.64 | 90.32 | 74.00 | -16.32 | Peak |
| 2 | 4892.000 | 32.22 | 9.49 | 35.51 | 42.76 | 48.96 | 74.00 | 25.04 | Peak |

Remarks: 1. Emission Level= Antenna Factor + Cable Loss + Reading - Amp Factor
 2. The emission levels that are 20dB below the official limit are not reported.

page

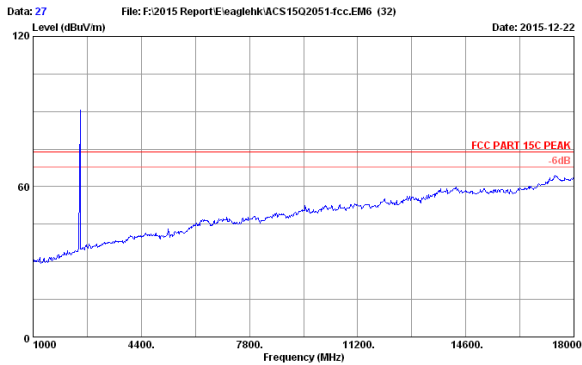

Site no. : 3m Chamber Data no. : 27
 Dis. / Ant. : 3m 2015 MCTD1209 3007 Ant. pol. : VERTICAL
 Limit : FCC PART 15C PEAK
 Env. / Ins. : 22.5°C/51.6%
 Engineer : Donjon_Huang
 EUT : Heavy Duty radio with AM/FM/USB/Bluetooth
 Power rating : DC 12V
 Test Mode : SPSK 2480MHz TX MODE
 M/N : JHD40BTBRP

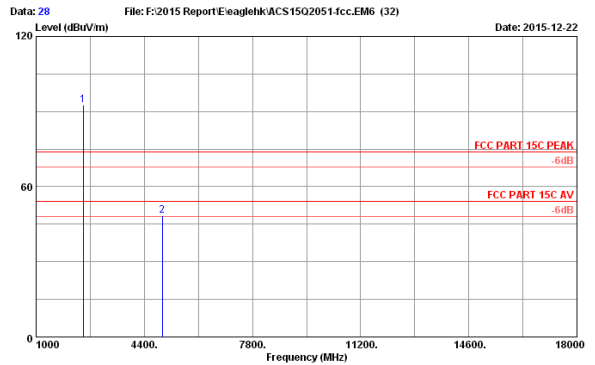

Site no. : 3m Chamber Data no. : 28
 Dis. / Ant. : 3m 2015 MCTD1209 3007 Ant. pol. : VERTICAL
 Limit : FCC PART 15C PEAK
 Env. / Ins. : 22.5°C/51.6%
 Engineer : Donjon_Huang
 EUT : Heavy Duty radio with AM/FM/USB/Bluetooth
 Power rating : DC 12V
 Test Mode : SPSK 2480MHz TX MODE
 M/N : JHD40BTBRP

| No. | Freq. (MHz) | Ant. Factor (dB/m) | Cable Loss (dB) | AMP factor (dB) | Reading (dBuV) | Emission Level (dBuV/m) | Limits (dBuV/m) | Margin (dB) | Remark |
|-----|-------------|--------------------|-----------------|-----------------|----------------|-------------------------|-----------------|-------------|--------|
| 1 | 2479.000 | 27.96 | 7.47 | 36.59 | 93.64 | 92.48 | 74.00 | -18.48 | Peak |
| 2 | 4960.000 | 32.14 | 9.52 | 35.47 | 42.33 | 48.52 | 74.00 | 25.48 | Peak |

Remarks: 1. Emission Level= Antenna Factor + Cable Loss + Reading - Amp Factor
 2. The emission levels that are 20dB below the official limit are not reported.

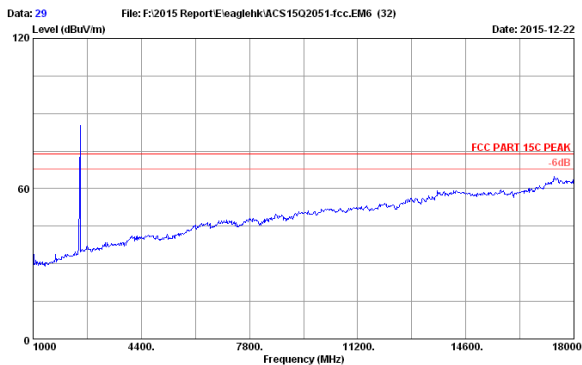

Site no. : 3m Chamber Data no. : 29
 Dis. / Ant. : 3m 2015 MCTD1209 3007 Ant. pol. : HORIZONTAL
 Limit : FCC PART 15C PEAK
 Env. / Ins. : 22.5°C/51.6%
 Engineer : Donjon_Huang
 EUT : Heavy Duty radio with AM/FM/USB/Bluetooth
 Power rating : DC 12V
 Test Mode : SPSK 2480MHz TX MODE
 M/N : JHD40BTBRP



Site no. : 3m Chamber Data no. : 30
 Dis. / Ant. : 3m 2015 MCTD1209 3007 Ant. pol. : HORIZONTAL
 Limit : FCC PART 15C PEAK
 Env. / Ins. : 22.5°C/51.6%
 Engineer : Donjon_Huang
 EUT : Heavy Duty radio with AM/FM/USB/Bluetooth
 Power rating : DC 12V
 Test Mode : SPSK 2480MHz TX MODE
 M/N : JHD40BTBRP

| No. | Freq. (MHz) | Ant. Factor (dB/m) | Cable Loss (dB) | AMP factor (dB) | Reading (dBuV) | Emission Level (dBuV/m) | Limits (dBuV/m) | Margin (dB) | Remark |
|-----|-------------|--------------------|-----------------|-----------------|----------------|-------------------------|-----------------|-------------|--------|
| 1 | 2479.000 | 27.96 | 7.47 | 36.59 | 90.27 | 89.11 | 74.00 | -15.11 | Peak |
| 2 | 4960.000 | 32.14 | 9.52 | 35.47 | 40.48 | 46.67 | 74.00 | 27.33 | Peak |

Remarks: 1. Emission Level= Antenna Factor + Cable Loss + Reading - Amp Factor
 2. The emission levels that are 20dB below the official limit are not reported.

5. CONDUCTED SPURIOUS EMISSIONS

5.1. Test Equipment

| Item | Equipment | Manufacturer | Model No. | Serial No. | Last Cal. | Cal. Interval |
|------|----------------------|----------------------------|---------------|------------|-----------|---------------|
| 1. | Spectrum | Agilent | N9030A | MY51380221 | Oct.18,15 | 1Year |
| 2. | Attenuator (20dB) | Agilent | 8491B | MY39262165 | Apr.28,15 | 1 Year |
| 3. | RF Cable | Marvelous Microwave Inc | SFL402105FLEX | NO.1 | Oct.17,15 | 1 Year |

5.2. Limit

In any 100kHz bandwidth outside the frequency bands in which the spread spectrum intentional radiator is operating, the radio frequency power that is produced by the intentional radiator shall be at least 20dB below that in the 100kHz bandwidth within the band that contains the highest level of the desired power.

5.3. Test Procedure

The transmitter output was connected to a spectrum analyzer, The resolution bandwidth is set to 100 kHz, The video bandwidth is set to 300 kHz and measure all the emissions detected.

5.4. Test result

PASS (The testing data was attached in the next pages.)

**Hopping Off
GFSK
2402MHz**

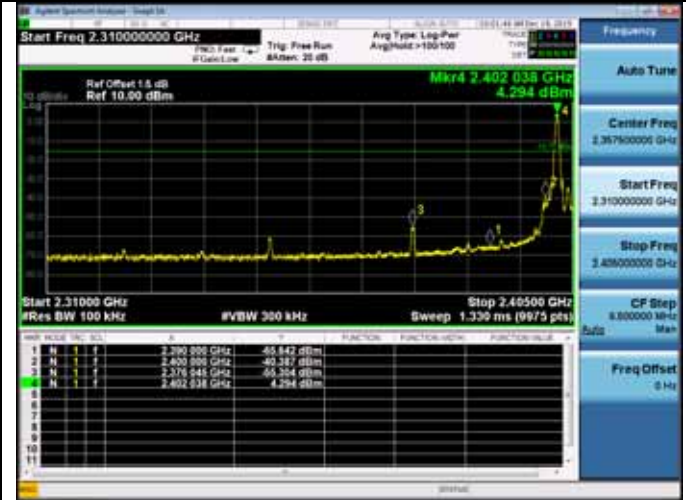
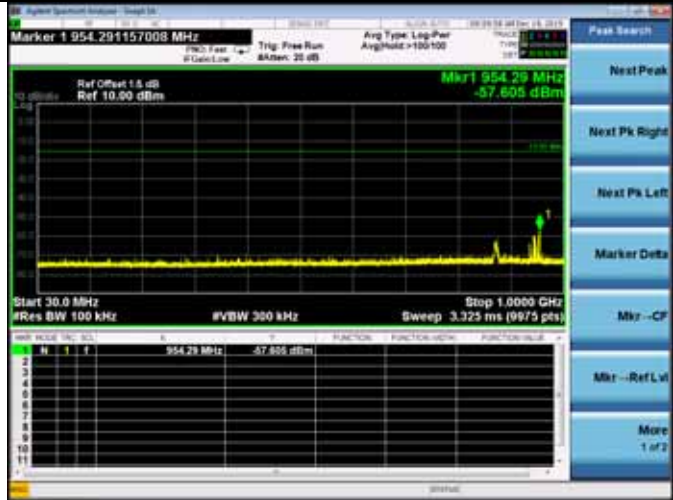

2441MHz

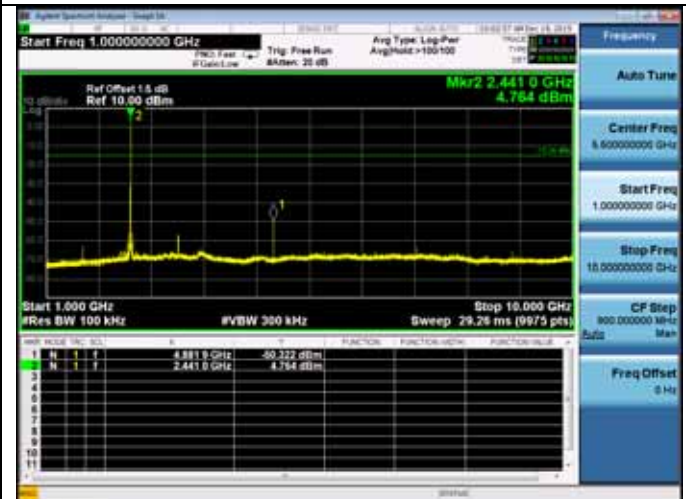
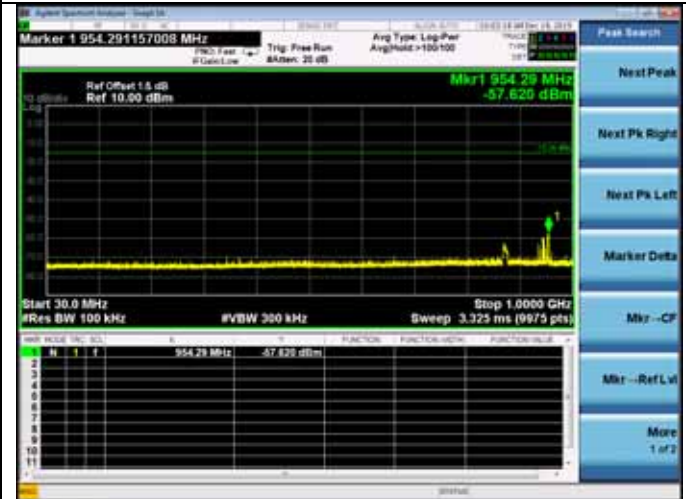
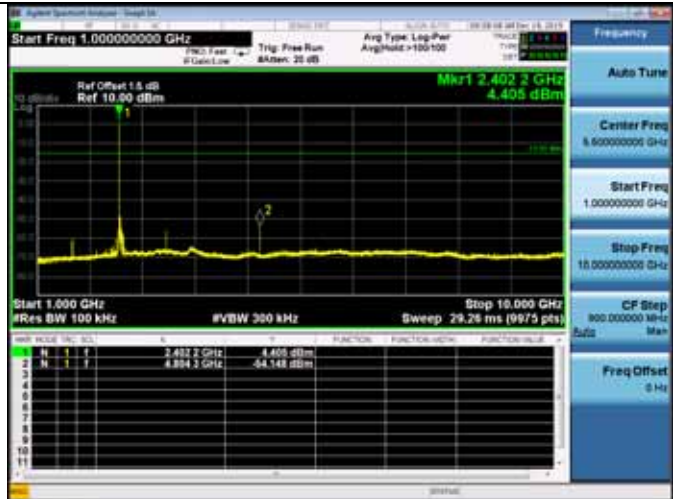

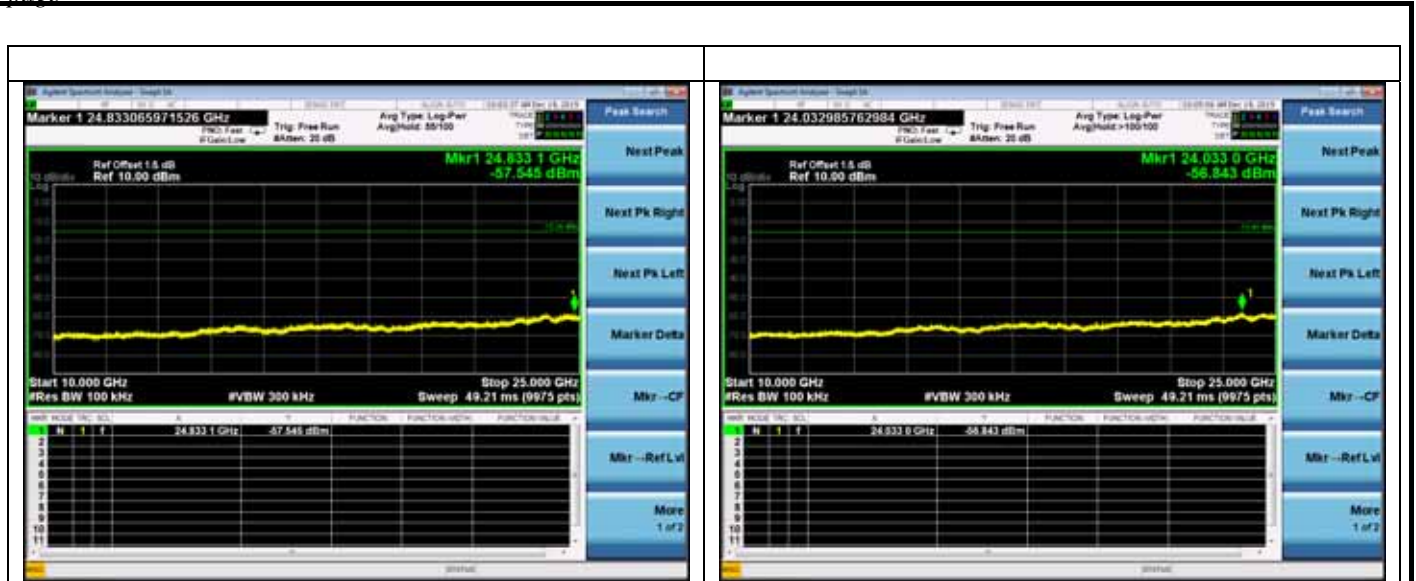

2480MHz



8-DPSK
2402MHz



page

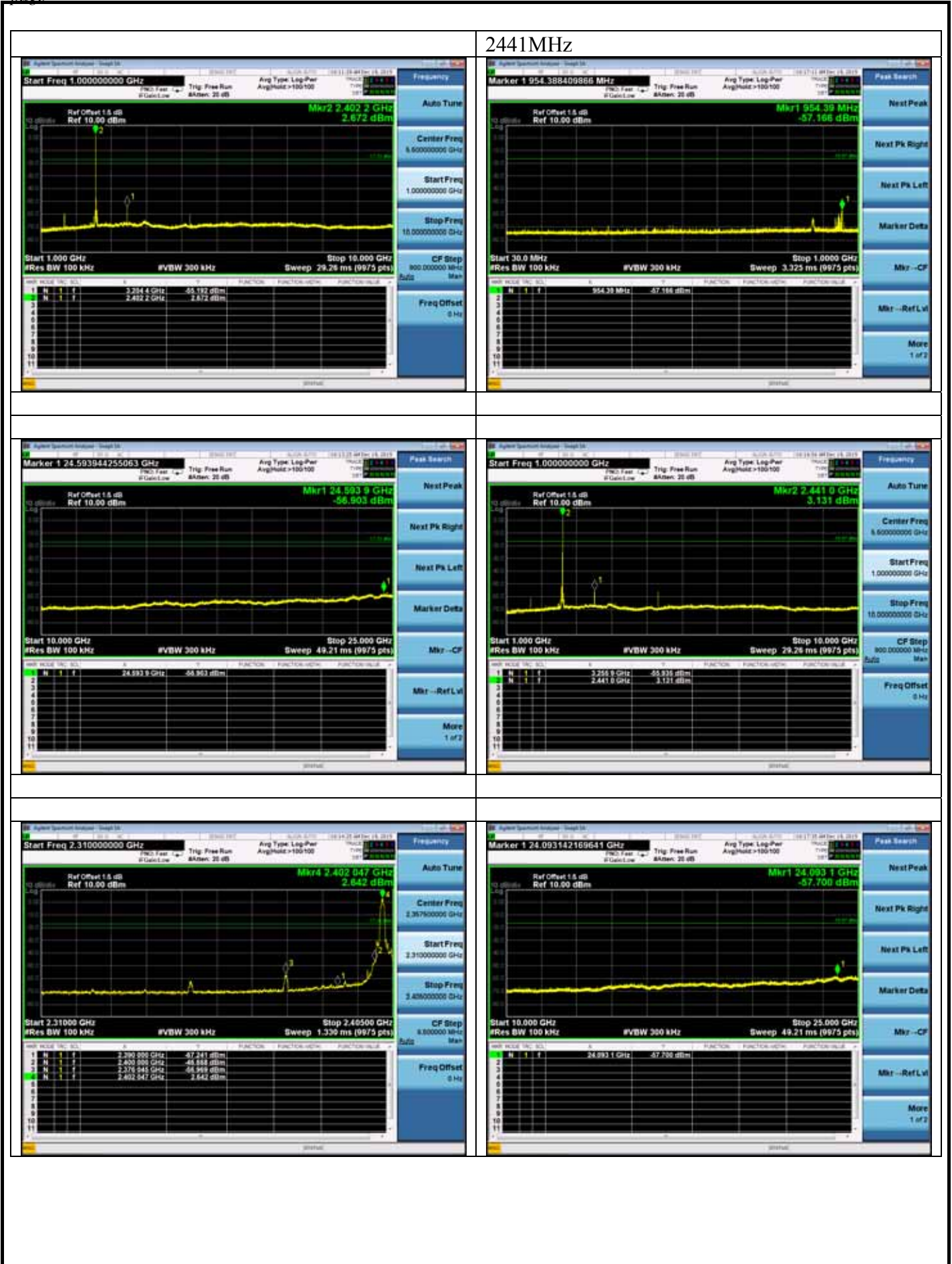

page



page

**Hopping On
GFSK**

8-DPSK

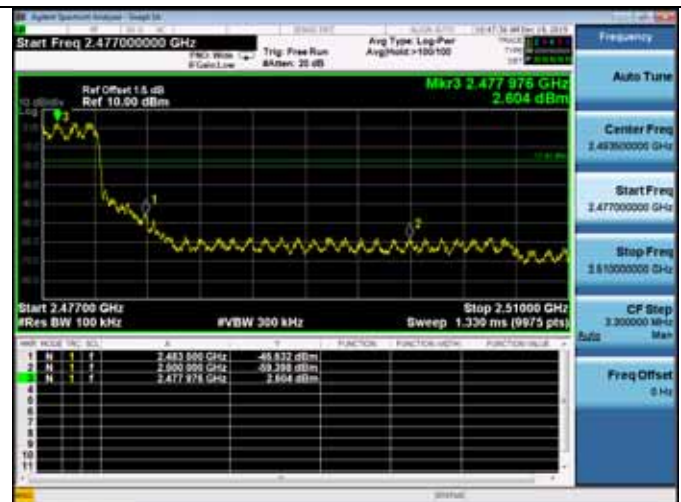
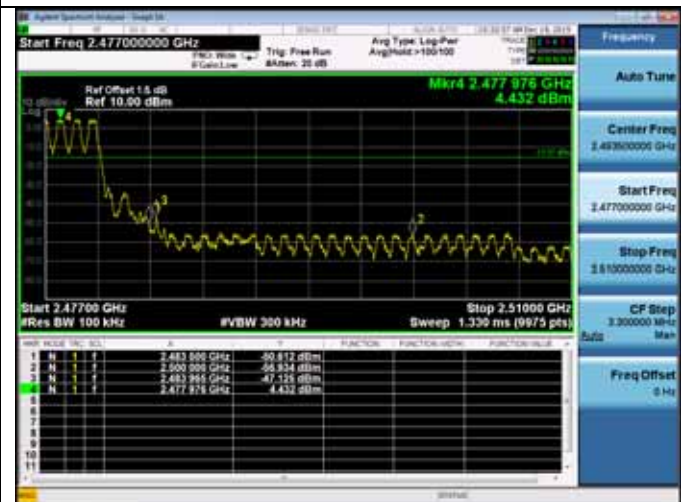
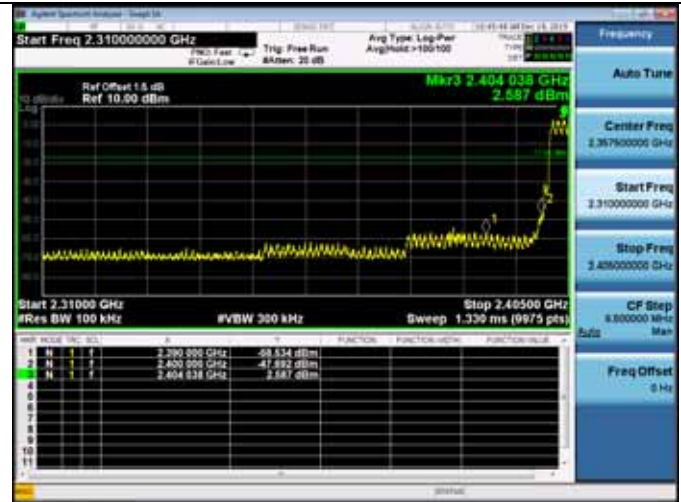
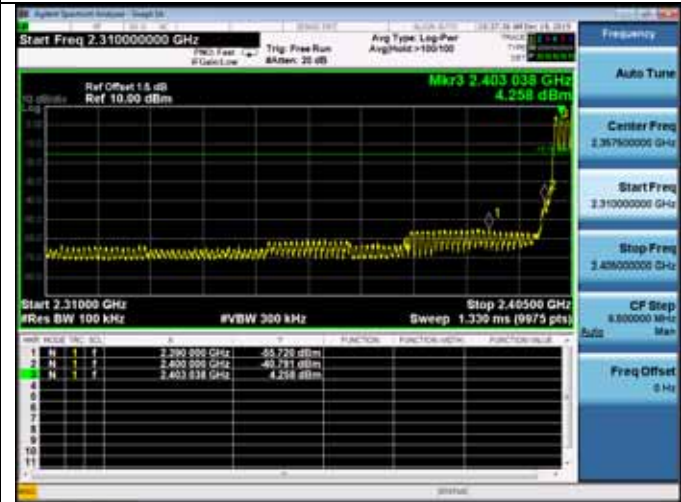

6. CARRIER FREQUENCY SEPARATION TEST

6.1. Test Equipment

| Item | Equipment | Manufacturer | Model No. | Serial No. | Last Cal. | Cal. Interval |
|------|-------------------|--------------|-------------|------------|------------|---------------|
| 1 | Spectrum Analyzer | Agilent | N9030A | MY51380221 | Oct.18,15 | 1Year |
| 2. | RF Cable | Hubersuhner | SUCOFLEX102 | 28620/2 | Apr. 28,15 | 1 Year |

6.2. Limit

Frequency hopping systems shall have hopping channel carrier frequency separated by a minimum of 25kHz or the 20dB bandwidth of the hopping channel, whichever is greater. Alternatively, frequency hopping systems operating in the 2400-2483.5 MHz band may have hopping channel carrier frequencies that are separated by 25 kHz or two-thirds of the 20 dB bandwidth of the hopping channel, whichever is greater, provided the systems operate with an output power no greater than 125 mW.

6.3. Test Results.

| | | |
|--|-------------------------|-------------------------|
| EUT: Heavy Duty radio with AM/FM/USB/Bluetooth | | |
| M/N: JHD40BTBRP | | |
| Test date: 2015-12-19 | Pressure: 101.4±1.0 kpa | Humidity: 51.5±3.0% |
| Tested by: Donjon_Huang | Test site: RF Site | Temperature: 22.3±0.6°C |

| Test Mode | Channel separation | Conclusion |
|-----------|--------------------|------------|
| 8-DPSK | 1.0MHz | PASS |
| GFSK | 1.0MHz | PASS |

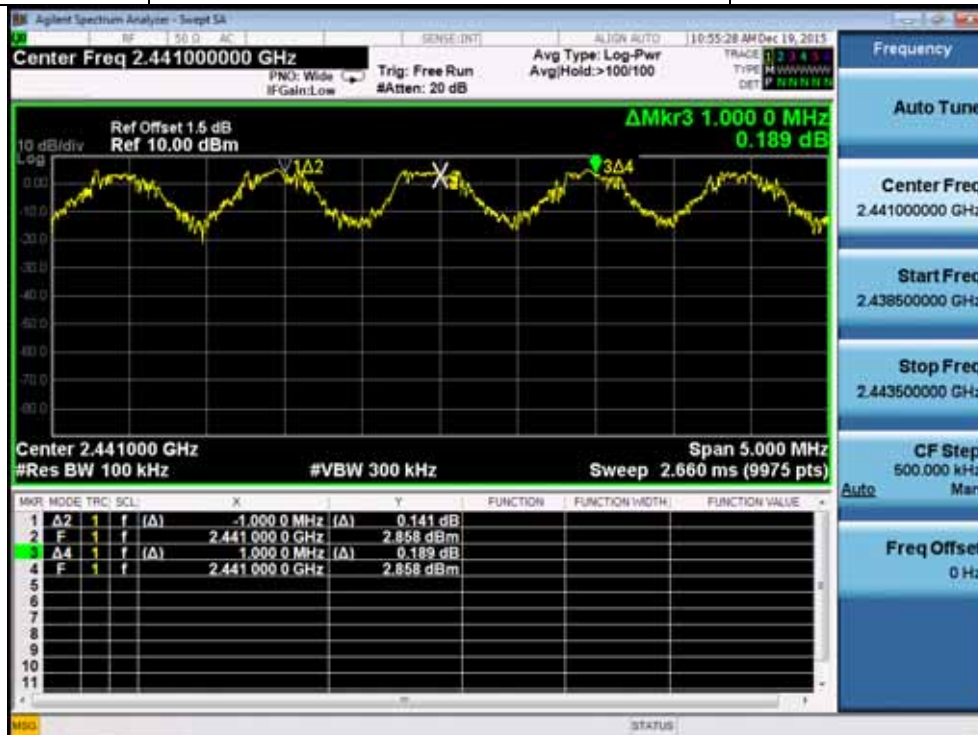

7. 20 DB BANDWIDTH TEST

7.1. Test Equipment

| Item | Equipment | Manufacturer | Model No. | Serial No. | Last Cal. | Cal. Interval |
|------|-------------------|--------------|-------------|------------|------------|---------------|
| 1. | Spectrum | Agilent | N9030A | MY51380221 | Oct.18,15 | 1 Year |
| 2. | Attenuator (20dB) | Agilent | 8491B | MY39262165 | Apr. 28,15 | 1 Year |
| 3. | RF Cable | Hubersuhner | SUCOFLEX102 | 28620/2 | Apr. 28,15 | 1 Year |

7.2. Limit

Intentional radiators operating under the alternative provisions to the general emission limits, as contained in §§ 15.217 through 15.257 and in Subpart E of this part, must be designed to ensure that the 20 dB bandwidth of the emission, or whatever bandwidth may otherwise be specified in the specific rule section under which the equipment operates, is contained within the frequency band designated in the rule section under which the equipment is operated.

7.3. Test Results

| | | |
|--|-------------------------|-----------------------|
| EUT: Heavy Duty radio with AM/FM/USB/Bluetooth | | |
| M/N: JHD40BTBRP | | |
| Test date: 2015-12-27 | Pressure: 101.4±1.0 kpa | Humidity: 50.5±3.0% |
| Tested by: Donjon_Huang | Test site: RF Site | Temperature: 20.4±0.6 |

| Test Mode | Frequency (MHz) | -20dB Bandwidth (KHz) | Limit (KHz) |
|-----------|-------------------|-------------------------|-------------|
| GFSK | 2402 | 834.2 | N/A |
| | 2441 | 832.0 | N/A |
| | 2480 | 828.8 | N/A |
| 8-DPSK | 2402 | 1205 | N/A |
| | 2441 | 1206 | N/A |
| | 2480 | 1206 | N/A |

Conclusion : PASS

page

GFSK

Test Frequency: 2402MHz

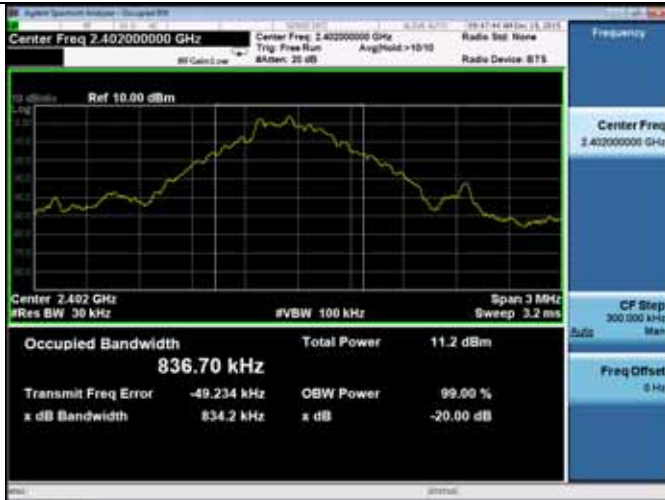

8-DPSK

Test Frequency: 2402MHz

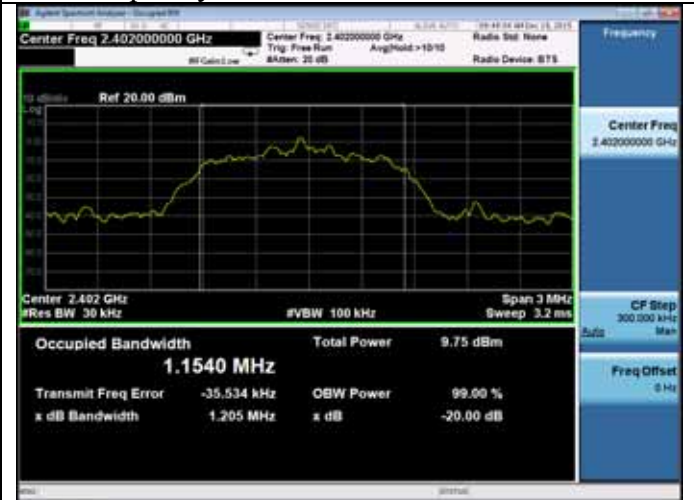

Test Frequency: 2441MHz

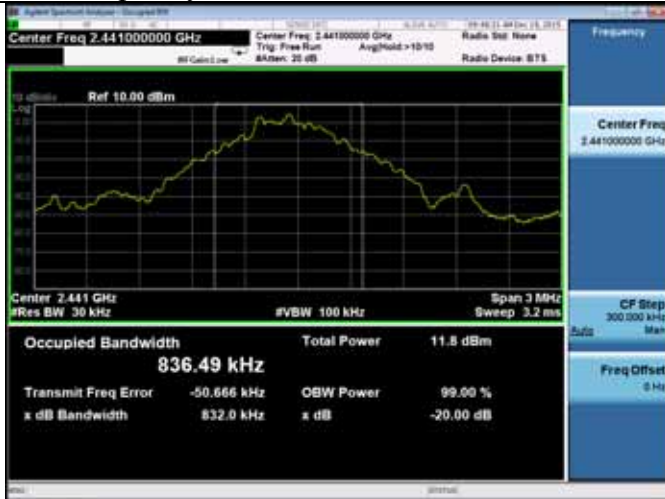

Test Frequency: 2441MHz



Test Frequency: 2480MHz



Test Frequency: 2480MHz

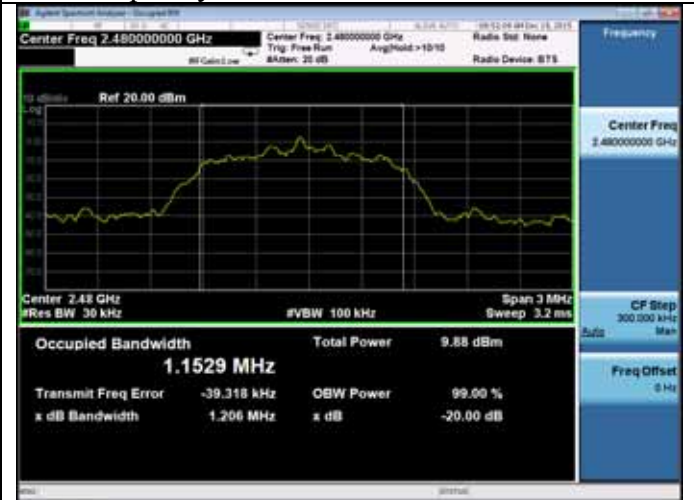

8. NUMBER OF HOPPING FREQUENCY TEST

8.1. Test Equipment

| Item | Equipment | Manufacturer | Model No. | Serial No. | Last Cal. | Cal. Interval |
|------|-------------------|--------------|-------------|------------|------------|---------------|
| 1 | Spectrum Analyzer | Agilent | N9030A | MY51380221 | Oct.18,15 | 1Year |
| 2. | RF Cable | Hubersuhner | SUCOFLEX102 | 28620/2 | Apr.28, 15 | 1 Year |

8.2. Limit

Frequency hopping systems in the 2400-2483.5 MHz band shall use at least 15 channels

8.3. Test Results

| | | |
|--|-------------------------|-------------------------|
| EUT: Heavy Duty radio with AM/FM/USB/Bluetooth | | |
| M/N: JHD40BTBRP | | |
| Test date: 2015-12-19 | Pressure: 101.4±1.0 kpa | Humidity: 51.5±3.0% |
| Tested by: Donjon_Huang | Test site: RF Site | Temperature: 22.3±0.6°C |

| Test Mode | Number of channel | Limit | Conclusion |
|-----------|-------------------|-------|------------|
| 8-DPSK | 79 | ≥15 | PASS |
| GFSK | 79 | ≥15 | PASS |

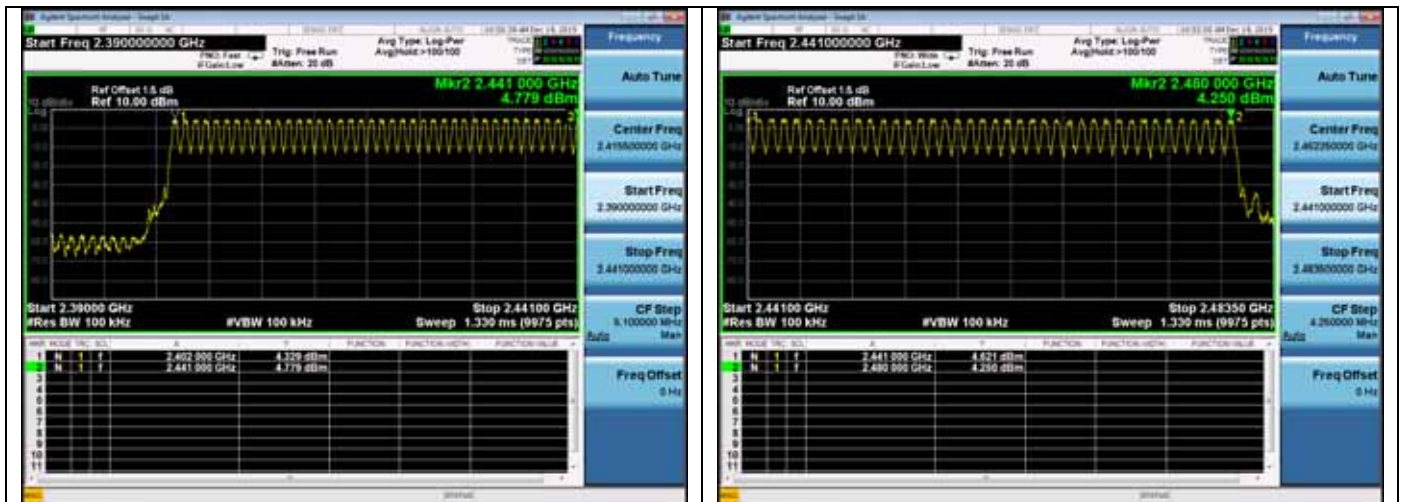

9. DWELL TIME

9.1. Test Equipment

| Item | Equipment | Manufacturer | Model No. | Serial No. | Last Cal. | Cal. Interval |
|------|-------------------|--------------|-------------|------------|------------|---------------|
| 1 | Spectrum Analyzer | Agilent | N9030A | MY51380221 | Oct.18,15 | 1Year |
| 2. | RF Cable | Hubersuhner | SUCOFLEX102 | 28620/2 | Apr.28, 15 | 1 Year |

9.2. Limit

The average time of occupancy on any channel shall not be greater than 0.4 seconds within a period of 0.4 seconds multiplied by the number of hopping channels employed.

9.3. Test Results

| | | |
|--|-------------------------|-------------------------|
| EUT: Heavy Duty radio with AM/FM/USB/Bluetooth | | |
| M/N: JHD40BTBRP | | |
| Test date: 2015-12-19 | Pressure: 101.4±1.0 kpa | Humidity: 51.5±3.0% |
| Tested by: Donjon_Huang | Test site: RF Site | Temperature: 22.3±0.6°C |

| Mode | dwell time | | Limit | Conclusion |
|--------|------------|--|--------|------------|
| GFSK | DH1 | 50hops/5s*0.4*79chanel*0.4354ms =137.586ms | <400ms | PASS |
| | DH3 | 25hops/5s*0.4*79chanel*1.6970ms =268.126ms | <400ms | PASS |
| | DH5 | 17hops/5s*0.4*79chanel*2.9530ms =317.270ms | <400ms | PASS |
| 8-DPSK | DH1 | 50hops/5s*0.4*79chanel*0.4588ms =144.981ms | <400ms | PASS |
| | DH3 | 25hops/5s*0.4*79chanel*1.700ms =268.600ms | <400ms | PASS |
| | DH5 | 17hops/5s*0.4*79chanel*2.962ms =318.237ms | <400ms | PASS |

Note: All the lower levels were signal from receiver's, and should not considered in here.

page

GFSK
DH 1

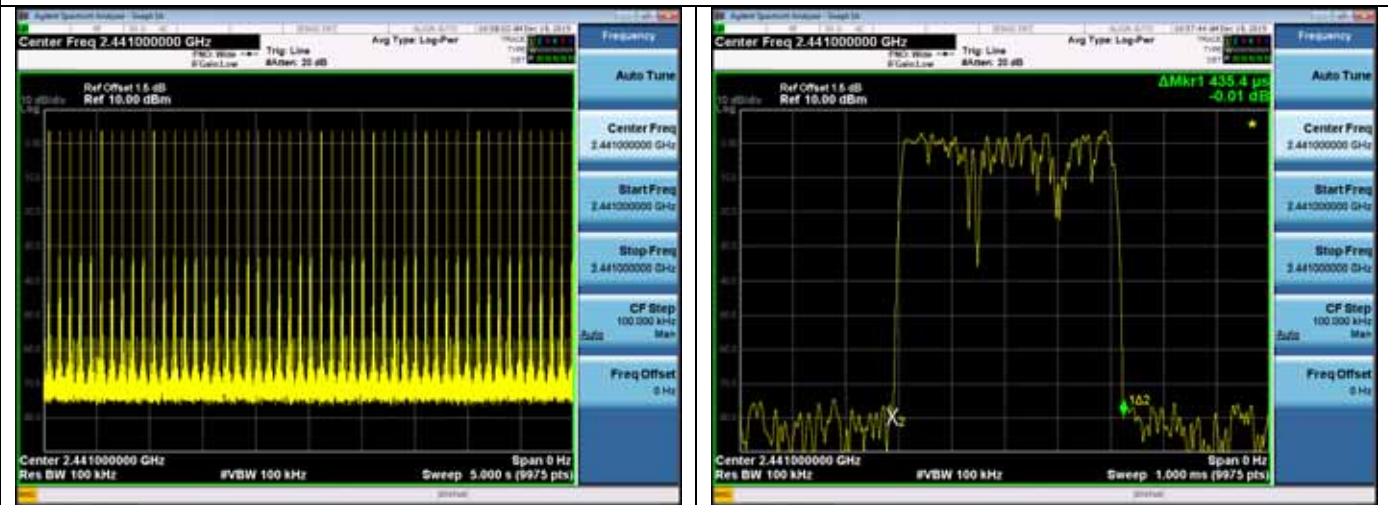

DH 3

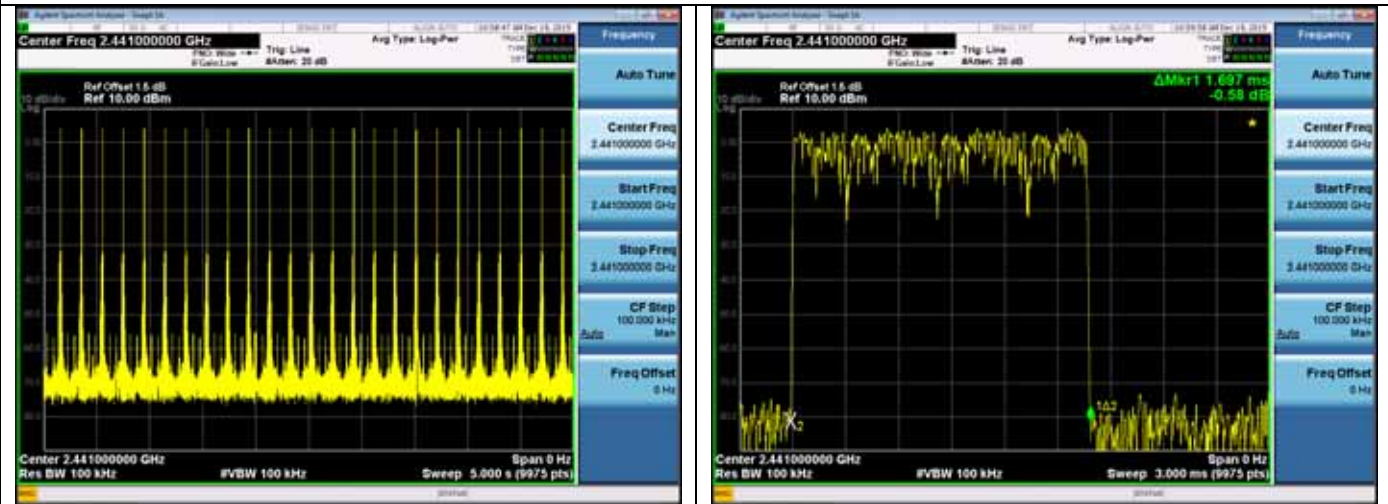

DH 5

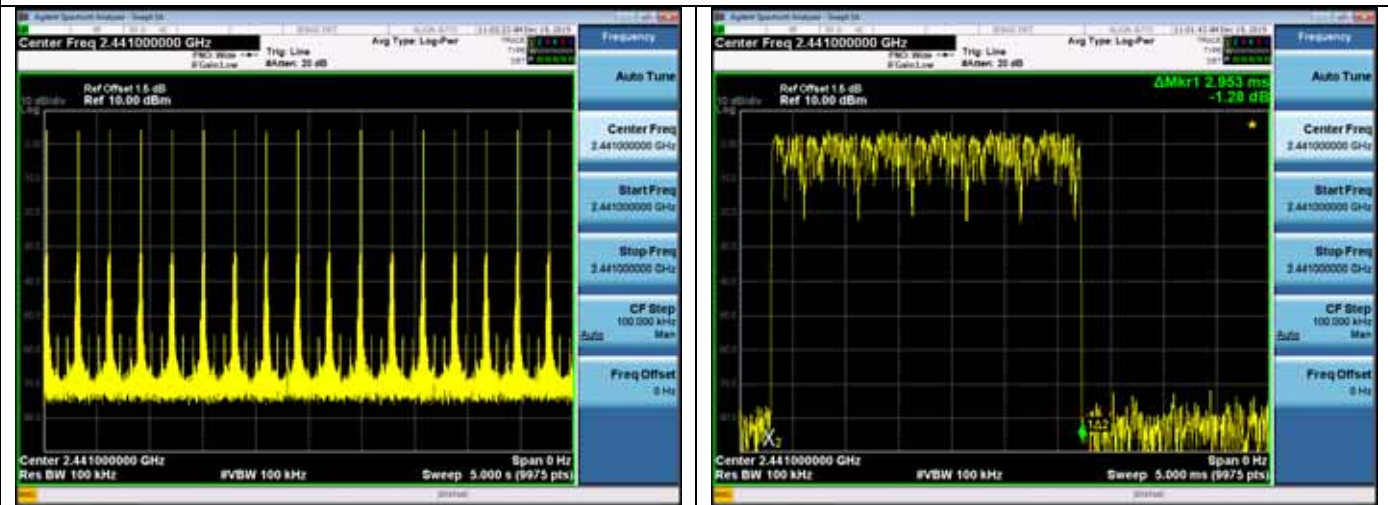

page

8-DPSK

3-DH 1

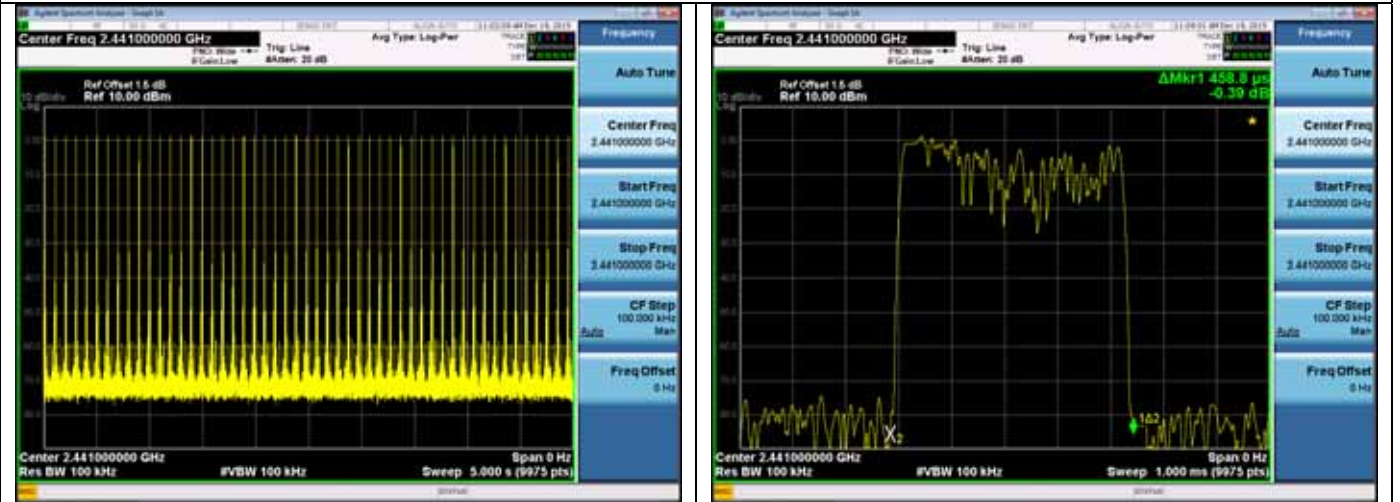

3-DH 3

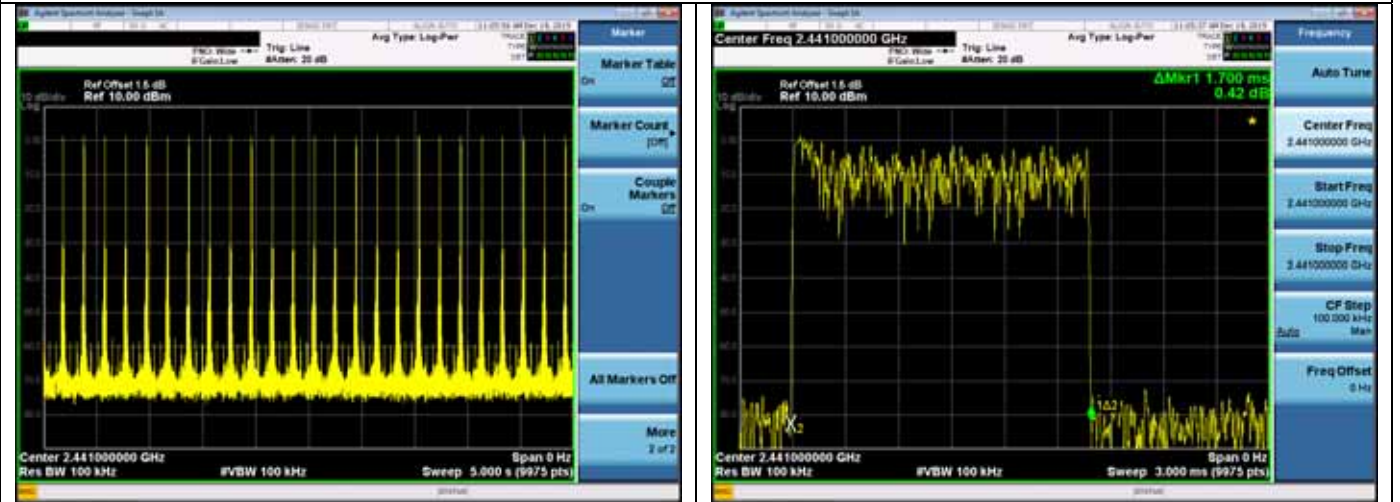

3-DH 5

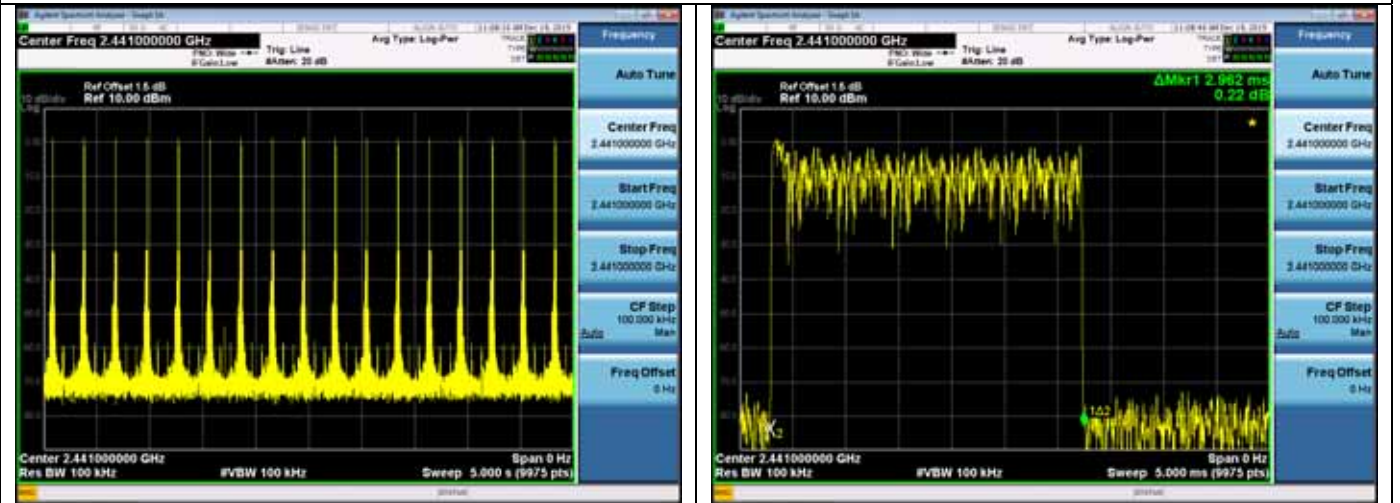

10. MAXIMUM PEAK OUTPUT POWER TEST

10.1. Test Equipment

| Item | Equipment | Manufacturer | Model No. | Serial No. | Last Cal. | Cal. Interval |
|------|-------------------|-------------------------|---------------|------------|-----------|---------------|
| 1. | Spectrum | Agilent | N9030A | MY51380221 | Oct.18,15 | 1 Year |
| 2. | Power meter | Anritsu | ML2487A | 6K00002472 | Aug.21,15 | 1 Year |
| 3. | Power sensor | Anritsu | MA2491A | 0033005 | Aug.21,15 | 1 Year |
| 4. | Attenuator (20dB) | Agilent | 8491B | MY39262165 | Apr.28,15 | 1 Year |
| 5. | RF Cable | Marvelous Microwave Inc | SFL402105FLEX | NO.1 | Oct.17,15 | 1 Year |

10.2. Limit

For frequency hopping systems operating in the 2400-2483.5 MHz band employing at least 75 non-overlapping hopping channels, and all frequency hopping systems in the 5725-5850 MHz band: 1 watt. For all other frequency hopping systems in the 2400-2483.5 MHz band: 0.125 watts.

10.3. Test Procedure

The power meter was used to measure for 2400-2483.5MHz band that is the peak output power directly.

10.4. Test Results

| EUT: Heavy Duty radio with AM/FM/USB/Bluetooth | | | |
|--|-----------------|---------------------------|----------------------|
| M/N: JHD40BTBRP | | | |
| Test date: 2015-12-27 | | Pressure: 101.3±1.0 kpa | Humidity: 50.4±1.0% |
| Tested by: Donjon_Huang | | Test site: RF site | Temperature:20.4±1.0 |
| Test Mode | Frequency (MHz) | Peak output Power (dBm) | Limit (dBm) |
| GFSK | 2402 | 4.233 | 30 |
| | 2441 | 4.887 | 30 |
| | 2480 | 4.589 | 30 |
| 8-DPSK | 2402 | 3.566 | 30 |
| | 2441 | 4.017 | 30 |
| | 2480 | 3.691 | 30 |
| Conclusion: PASS | | | |

11. BAND EDGE COMPLIANCE TEST

11.1. Test Equipment

| Item | Equipment | Manufacturer | Model No. | Serial No. | Last Cal. | Cal. Interval |
|------|--------------|--------------|-------------|-------------|-----------|---------------|
| 1. | Spectrum | Agilent | E4446A | US44300459 | Apr.28,15 | 1 Year |
| 2. | Amp | HP | 8449B | 3008A02495 | Apr.28,15 | 1 Year |
| 3. | Horn Antenna | ETC | MCTD 1209 | DRH15F03007 | Feb.03,15 | 1 Year |
| 4. | HF Cable | Hubersuhner | Sucoflex104 | 274094/4 | Apr.28,15 | 1 Year |

11.2. Limit

All the lower and upper band-edges emissions appearing within 2310MHz to 2390MHz and 2483.5MHz to 2500MHz restricted frequency bands shall not exceed the limits shown in 15.209, all the other emissions outside operation frequency band 2400MHz to 2483.5MHz shall be at least 20dB below the fundamental emissions, or comply with 15.209 limits.

11.3. Test Produce

For upper band emissions that are up to two bandwidths(2MHz) away (2483.5MHz to 2485.5MHz) from the band-edge use below produce:

1. Choose a spectrum analyzer span that encompasses both the peak of the fundamental emission and the band-edge emission under investigation. Set the analyzer RBW to 100KHz and with a video bandwidth 300KHz. Record the peak levels of the fundamental emission and the relevant band-edge emission, Observe the stored trace and measure the amplitude delta between the peak of the fundamental and the peak of the band-edge emission. This is not a field strength measurement, it is only a relative measurement to determine the amount by which the emission drops at the band edge relative to the highest fundamental emission level.
2. Subtract the delta measured in step (1) from the maximum field strengths measured in clause 4 .The resultant field strengths are then used to determine band-edge compliance as required by Section 15.205

For emissions above two bandwidths away from the band-edge use below produce:

1. The EUT is placed on a turntable, which is 0.8m above the ground plane and worked at highest radiated power.
2. The turntable was rotated for 360 degrees to determine the position of maximum emission level.
3. EUT is set 3m away from the receiving antenna, which is varied from 1m to 4m to find out the highest emission.
4. Set the spectrum analyzer in the following setting in order to capture the lower and upperband-edges of the emission:
 - (a) PEAK: RBW=1MHz ;VBW=3MHz, PK detector, Sweep=AUTO
 - (b) This is pulse Modulation device a duty cycle factor was used to calculate average level based measured peak level.

11.4. Test Results

Pass (The testing data was attached in the next pages.)

Note: If the PK measured levels comply with average limit, then the average level were deemed to comply with average limit.

page

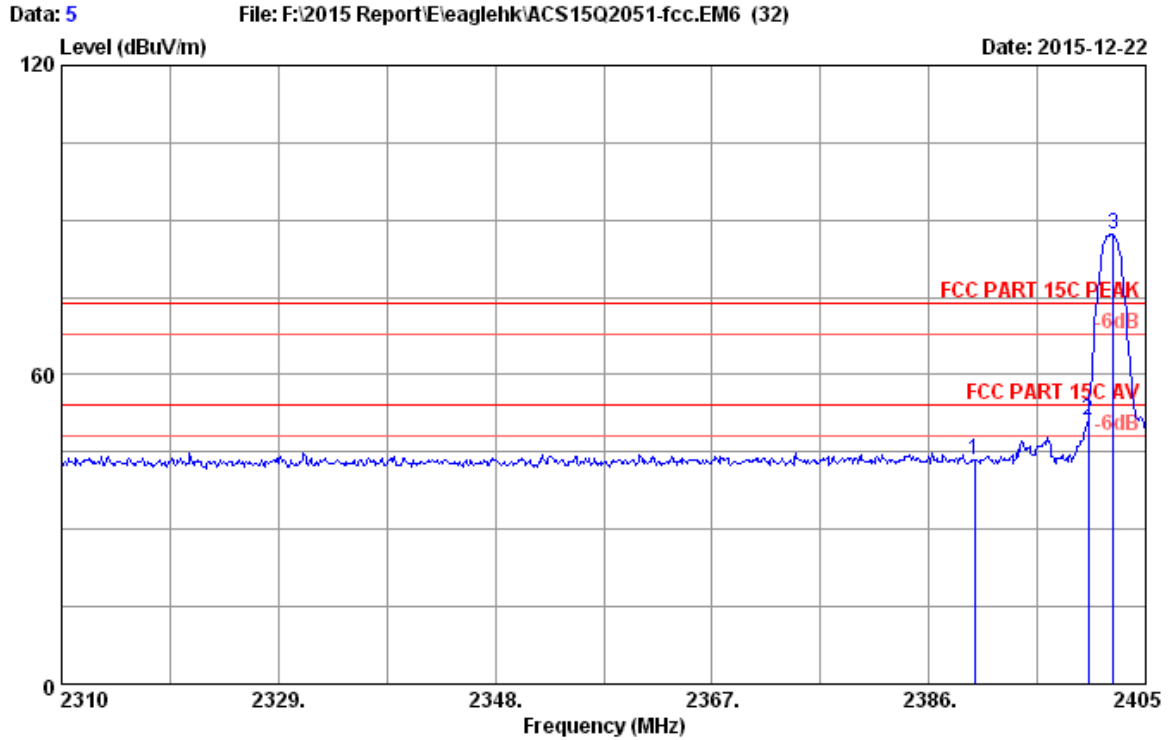

Site no. : 3m Chamber Data no. : 5
 Dis. / Ant. : 3m 2015 MCTD1209 3007 Ant. pol. : HORIZONTAL
 Limit : FCC PART 15C PEAK
 Env. / Ins. : 22.5°C/51.6%
 Engineer : Donjon_Huang
 EUT : Heavy Duty radio with AM/FM/USB/Bluetooth
 Power rating : DC 12V
 Test Mode : GFSK 2402MHz TX MODE
 M/N : JHD40BTBRP

| No. | Freq. (MHz) | Ant. Factor (dB/m) | Cable Loss (dB) | AMP factor (dB) | Reading (dBuV) | Emission Level (dBuV/m) | Limits (dBuV/m) | Margin (dB) | Remark |
|-----|-------------|--------------------|-----------------|-----------------|----------------|-------------------------|-----------------|-------------|--------|
| 1 | 2390.000 | 27.78 | 7.28 | 36.62 | 44.95 | 43.39 | 74.00 | 30.61 | Peak |
| 2 | 2400.000 | 27.80 | 7.32 | 36.62 | 52.74 | 51.24 | 74.00 | 22.76 | Peak |
| 3 | 2402.150 | 27.80 | 7.32 | 36.62 | 88.60 | 87.10 | 74.00 | -13.10 | Peak |

Remarks: 1. Emission Level= Antenna Factor + Cable Loss + Reading - Amp Factor
 2. The emission levels that are 20dB below the official limit are not reported.

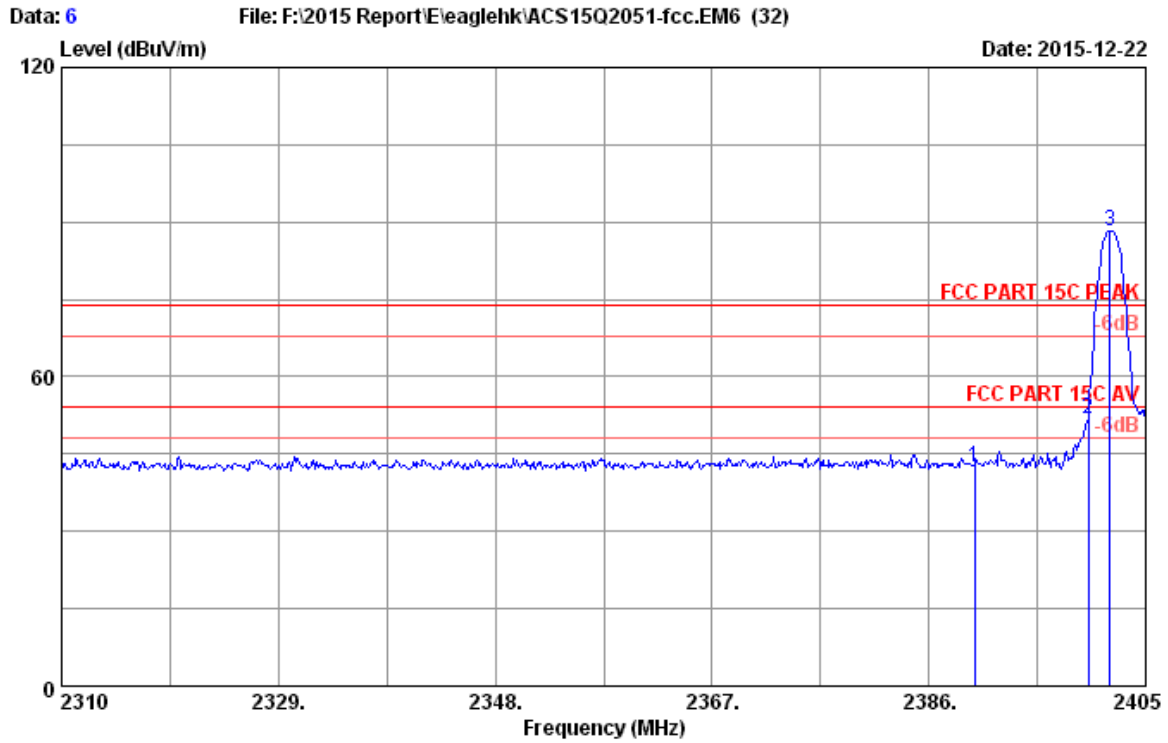

Site no. : 3m Chamber Data no. : 6
 Dis. / Ant. : 3m 2015 MCTD1209 3007 Ant. pol. : VERTICAL
 Limit : FCC PART 15C PEAK
 Env. / Ins. : 22.5°C/51.6%
 Engineer : Donjon_Huang
 EUT : Heavy Duty radio with AM/FM/USB/Bluetooth
 Power rating : DC 12V
 Test Mode : GFSK 2402MHz TX MODE
 M/N : JHD40BTBRP

| No. | Freq. (MHz) | Ant. Factor (dB/m) | Cable Loss (dB) | AMP factor (dB) | Reading (dBuV) | Emission Level (dBuV/m) | Limits (dBuV/m) | Margin (dB) | Remark |
|-----|-------------|--------------------|-----------------|-----------------|----------------|-------------------------|-----------------|-------------|--------|
| 1 | 2390.000 | 27.78 | 7.28 | 36.62 | 44.09 | 42.53 | 74.00 | 31.47 | Peak |
| 2 | 2400.000 | 27.80 | 7.32 | 36.62 | 53.15 | 51.65 | 74.00 | 22.35 | Peak |
| 3 | 2401.865 | 27.80 | 7.32 | 36.62 | 89.63 | 88.13 | 74.00 | -14.13 | Peak |

Remarks: 1. Emission Level= Antenna Factor + Cable Loss + Reading - Amp Factor
 2. The emission levels that are 20dB below the official limit are not reported.

page

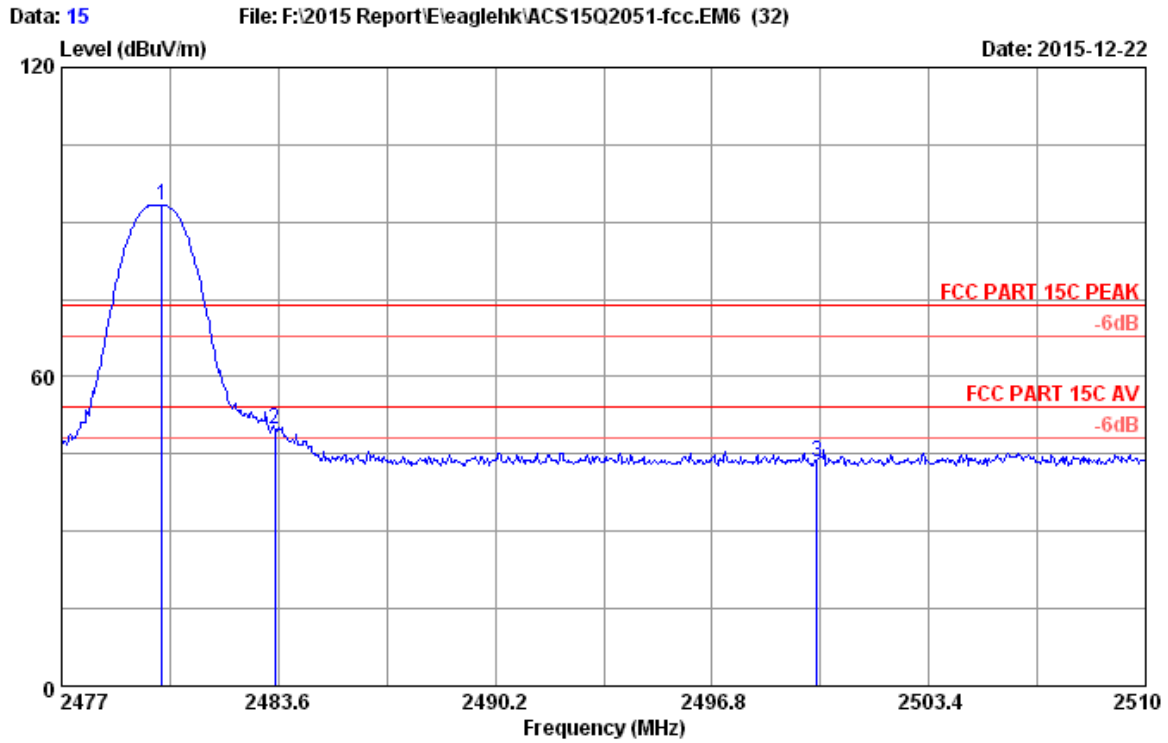

Site no. : 3m Chamber Data no. : 15
 Dis. / Ant. : 3m 2015 MCTD1209 3007 Ant. pol. : VERTICAL
 Limit : FCC PART 15C PEAK
 Env. / Ins. : 22.5°C/51.6%
 Engineer : Donjon_Huang
 EUT : Heavy Duty radio with AM/FM/USB/Bluetooth
 Power rating : DC 12V
 Test Mode : GFSK 2480MHz TX MODE
 M/N : JHD40BTBRP

| No. | Freq. (MHz) | Ant. Factor (dB/m) | Cable Loss (dB) | AMP factor (dB) | Reading (dBuV) | Emission Level (dBuV/m) | Limits (dBuV/m) | Margin (dB) | Remark |
|-----|-------------|--------------------|-----------------|-----------------|----------------|-------------------------|-----------------|-------------|--------|
| 1 | 2480.069 | 27.96 | 7.47 | 36.59 | 94.45 | 93.29 | 74.00 | -19.29 | Peak |
| 2 | 2483.500 | 27.97 | 7.51 | 36.59 | 51.00 | 49.89 | 74.00 | 24.11 | Peak |
| 3 | 2500.000 | 28.00 | 7.51 | 36.58 | 44.44 | 43.37 | 74.00 | 30.63 | Peak |

Remarks: 1. Emission Level= Antenna Factor + Cable Loss + Reading - Amp Factor
 2. The emission levels that are 20dB below the official limit are not reported.

page

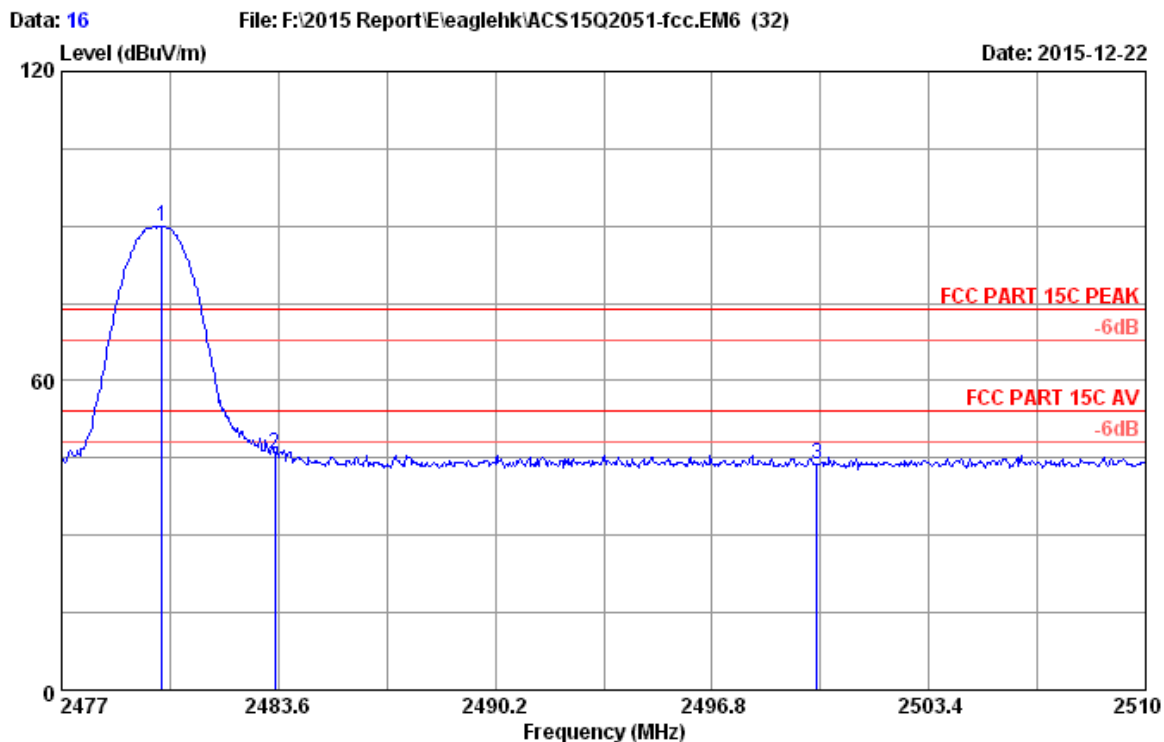

Site no. : 3m Chamber Data no. : 16
 Dis. / Ant. : 3m 2015 MCTD1209 3007 Ant. pol. : HORIZONTAL
 Limit : FCC PART 15C PEAK
 Env. / Ins. : 22.5°C/51.6%
 Engineer : Donjon_Huang
 EUT : Heavy Duty radio with AM/FM/USB/Bluetooth
 Power rating : DC 12V
 Test Mode : GFSK 2480MHz TX MODE
 M/N : JHD40BTBRP

| No. | Freq. (MHz) | Ant. Factor (dB/m) | Cable Loss (dB) | AMP factor (dB) | Reading (dBuV) | Emission Level (dBuV/m) | Limits (dBuV/m) | Margin (dB) | Remark |
|-----|-------------|--------------------|-----------------|-----------------|----------------|-------------------------|-----------------|-------------|--------|
| 1 | 2480.069 | 27.96 | 7.47 | 36.59 | 90.97 | 89.81 | 74.00 | -15.81 | Peak |
| 2 | 2483.500 | 27.97 | 7.51 | 36.59 | 46.98 | 45.87 | 74.00 | 28.13 | Peak |
| 3 | 2500.000 | 28.00 | 7.51 | 36.58 | 44.96 | 43.89 | 74.00 | 30.11 | Peak |

Remarks: 1. Emission Level= Antenna Factor + Cable Loss + Reading - Amp Factor
 2. The emission levels that are 20dB below the official limit are not reported.

page

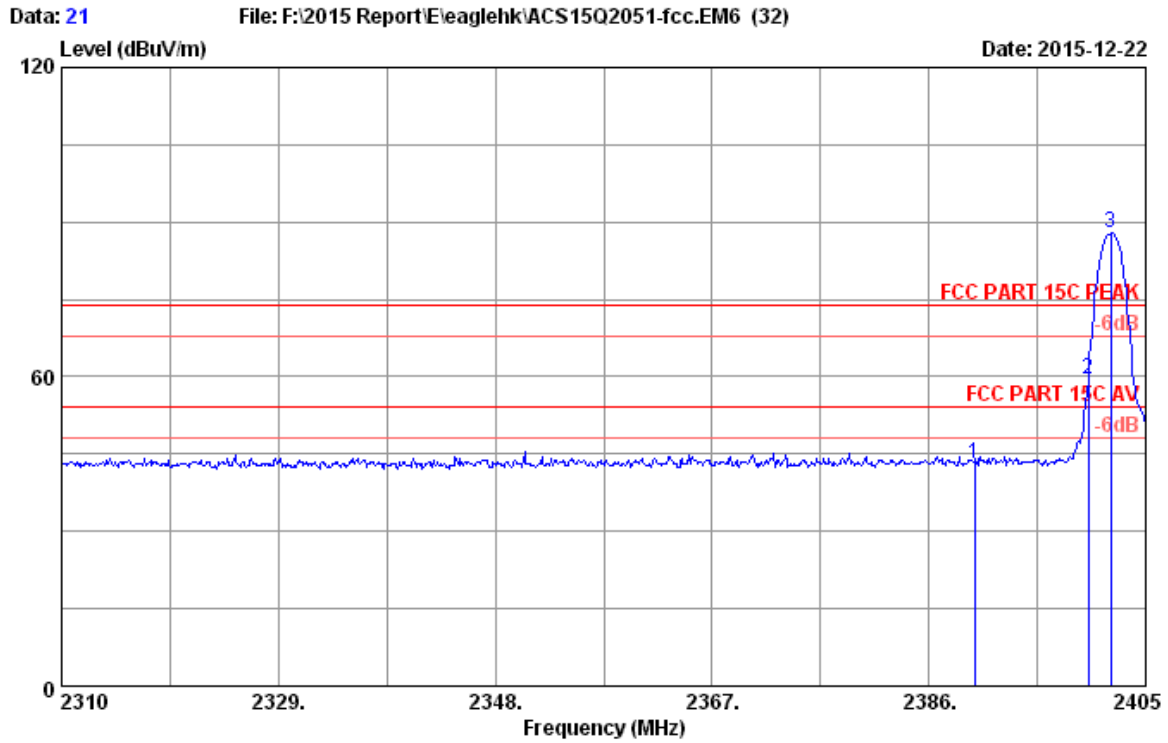

Site no. : 3m Chamber Data no. : 21
 Dis. / Ant. : 3m 2015 MCTD1209 3007 Ant. pol. : VERTICAL
 Limit : FCC PART 15C PEAK
 Env. / Ins. : 22.5°C/51.6%
 Engineer : Donjon_Huang
 EUT : Heavy Duty radio with AM/FM/USB/Bluetooth
 Power rating : DC 12V
 Test Mode : 8DPSK 2402MHz TX MODE
 M/N : JHD40BTBRP

| No. | Freq. (MHz) | Ant. Factor (dB/m) | Cable Loss (dB) | AMP factor (dB) | Reading (dBuV) | Emission Level (dBuV/m) | Limits (dBuV/m) | Margin (dB) | Remark |
|-----|-------------|--------------------|-----------------|-----------------|----------------|-------------------------|-----------------|-------------|--------|
| 1 | 2390.000 | 27.78 | 7.28 | 36.62 | 44.58 | 43.02 | 74.00 | 30.98 | Peak |
| 2 | 2400.000 | 27.80 | 7.32 | 36.62 | 60.90 | 59.40 | 74.00 | 14.60 | Peak |
| 3 | 2401.960 | 27.80 | 7.32 | 36.62 | 89.43 | 87.93 | 74.00 | -13.93 | Peak |

Remarks: 1. Emission Level= Antenna Factor + Cable Loss + Reading - Amp Factor
 2. The emission levels that are 20dB below the official limit are not reported.

page

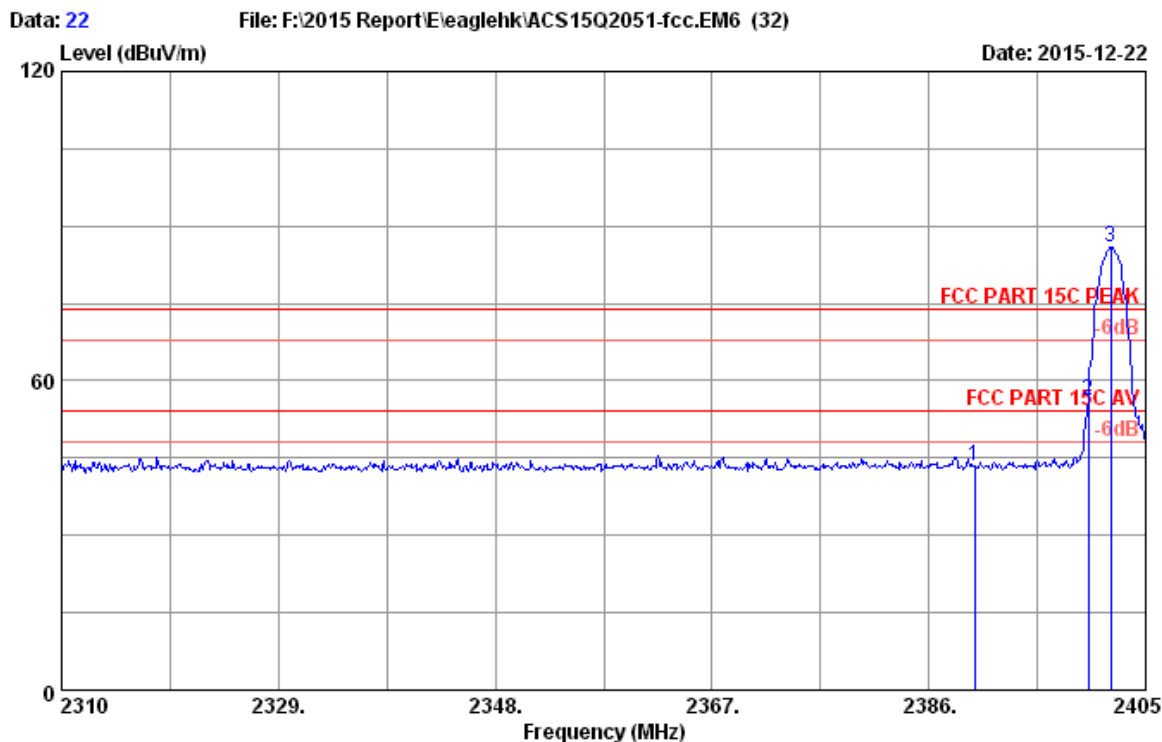

Site no. : 3m Chamber Data no. : 22
 Dis. / Ant. : 3m 2015 MCTD1209 3007 Ant. pol. : HORIZONTAL
 Limit : FCC PART 15C PEAK
 Env. / Ins. : 22.5°C/51.6%
 Engineer : Donjon_Huang
 EUT : Heavy Duty radio with AM/FM/USB/Bluetooth
 Power rating : DC 12V
 Test Mode : 8DPSK 2402MHz TX MODE
 M/N : JHD40BTBRP

| No. | Freq. (MHz) | Ant. Factor (dB/m) | Cable Loss (dB) | AMP factor (dB) | Reading (dBuV) | Emission Level (dBuV/m) | Limits (dBuV/m) | Margin (dB) | Remark |
|-----|-------------|--------------------|-----------------|-----------------|----------------|-------------------------|-----------------|-------------|--------|
| 1 | 2390.000 | 27.78 | 7.28 | 36.62 | 44.98 | 43.42 | 74.00 | 30.58 | Peak |
| 2 | 2400.000 | 27.80 | 7.32 | 36.62 | 57.57 | 56.07 | 74.00 | 17.93 | Peak |
| 3 | 2401.960 | 27.80 | 7.32 | 36.62 | 87.55 | 86.05 | 74.00 | -12.05 | Peak |

Remarks: 1. Emission Level= Antenna Factor + Cable Loss + Reading - Amp Factor
 2. The emission levels that are 20dB below the official limit are not reported.

page

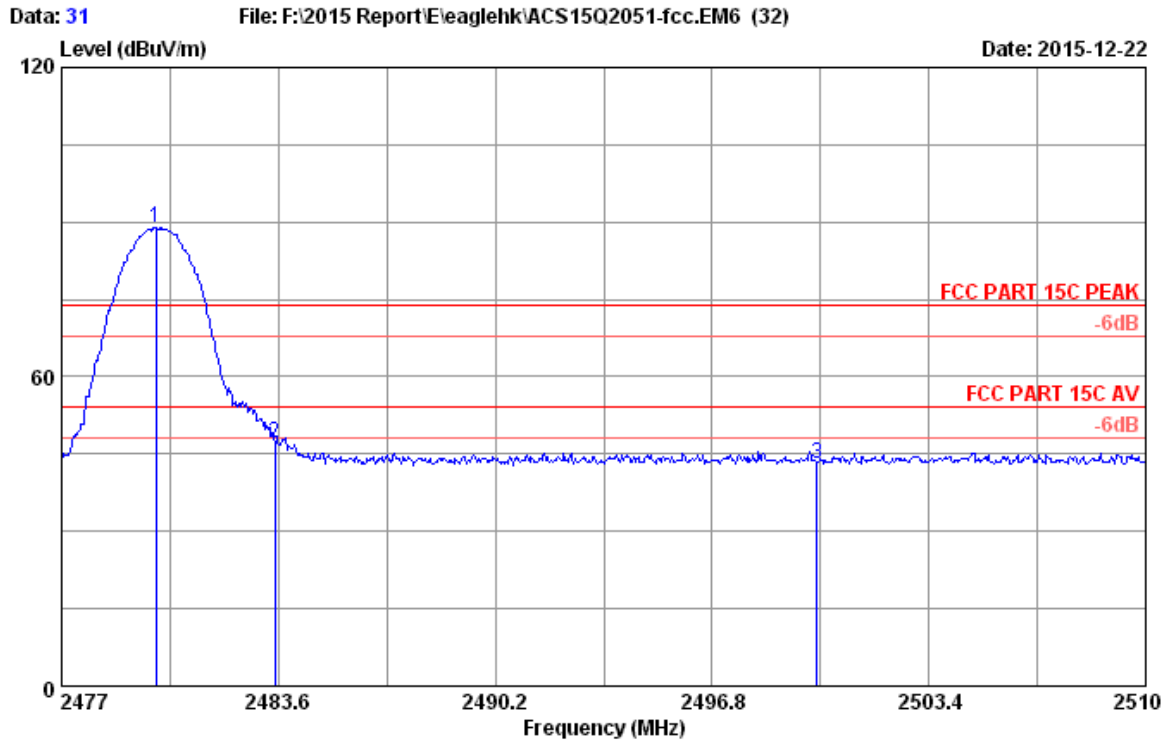

Site no. : 3m Chamber Data no. : 31
 Dis. / Ant. : 3m 2015 MCTD1209 3007 Ant. pol. : HORIZONTAL
 Limit : FCC PART 15C PEAK
 Env. / Ins. : 22.5°C/51.6%
 Engineer : Donjon_Huang
 EUT : Heavy Duty radio with AM/FM/USB/Bluetooth
 Power rating : DC 12V
 Test Mode : 8DPSK 2480MHz TX MODE
 M/N : JHD40BTBRP

| No. | Freq. (MHz) | Ant. Factor (dB/m) | Cable Loss (dB) | AMP factor (dB) | Reading (dBuV) | Emission Level (dBuV/m) | Limits (dBuV/m) | Margin (dB) | Remark |
|-----|-------------|--------------------|-----------------|-----------------|----------------|-------------------------|-----------------|-------------|--------|
| 1 | 2479.871 | 27.96 | 7.47 | 36.59 | 90.02 | 88.86 | 74.00 | -14.86 | Peak |
| 2 | 2483.500 | 27.97 | 7.51 | 36.59 | 48.35 | 47.24 | 74.00 | 26.76 | Peak |
| 3 | 2500.000 | 28.00 | 7.51 | 36.58 | 44.23 | 43.16 | 74.00 | 30.84 | Peak |

Remarks: 1. Emission Level= Antenna Factor + Cable Loss + Reading - Amp Factor
 2. The emission levels that are 20dB below the official limit are not reported.

page

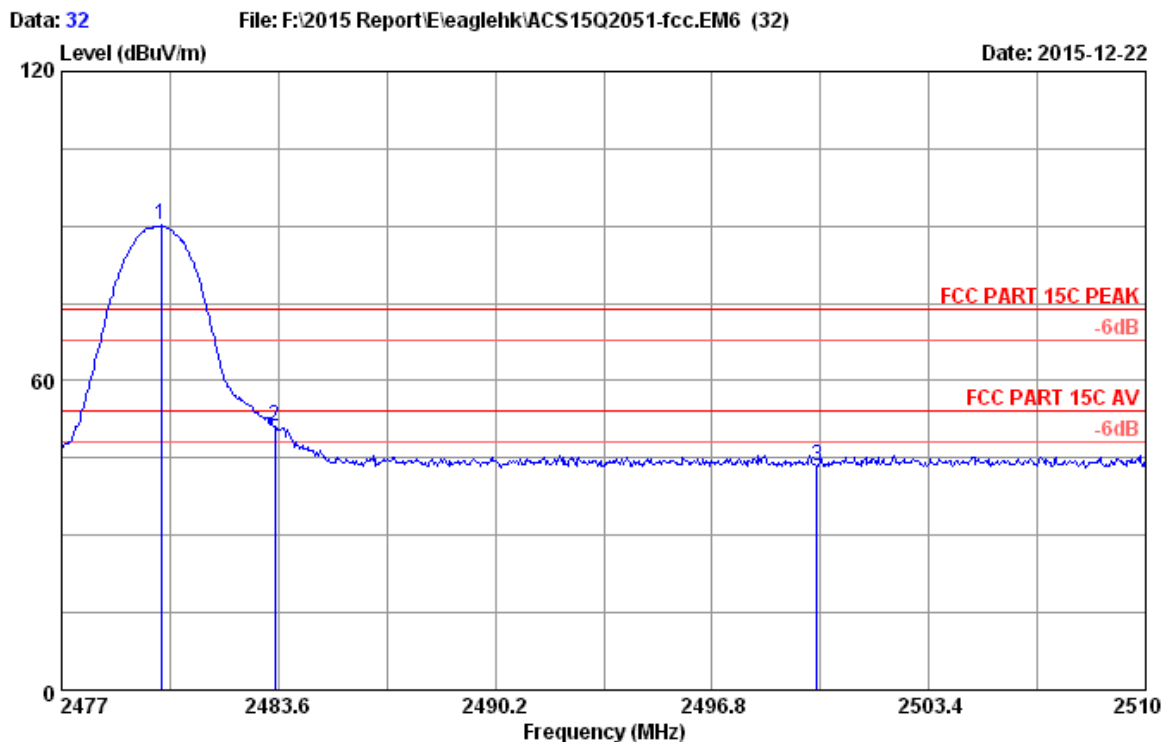

Site no. : 3m Chamber Data no. : 32
 Dis. / Ant. : 3m 2015 MCTD1209 3007 Ant. pol. : VERTICAL
 Limit : FCC PART 15C PEAK
 Env. / Ins. : 22.5°C/51.6%
 Engineer : Donjon_Huang
 EUT : Heavy Duty radio with AM/FM/USB/Bluetooth
 Power rating : DC 12V
 Test Mode : 8DPSK 2480MHz TX MODE
 M/N : JHD40BTBRP

| No. | Freq. (MHz) | Ant. Factor (dB/m) | Cable Loss (dB) | AMP factor (dB) | Reading (dBuV) | Emission Level (dBuV/m) | Limits (dBuV/m) | Margin (dB) | Remark |
|-----|-------------|--------------------|-----------------|-----------------|----------------|-------------------------|-----------------|-------------|--------|
| 1 | 2480.036 | 27.96 | 7.47 | 36.59 | 91.27 | 90.11 | 74.00 | -16.11 | Peak |
| 2 | 2483.500 | 27.97 | 7.51 | 36.59 | 52.21 | 51.10 | 74.00 | 22.90 | Peak |
| 3 | 2500.000 | 28.00 | 7.51 | 36.58 | 44.56 | 43.49 | 74.00 | 30.51 | Peak |

Remarks: 1. Emission Level= Antenna Factor + Cable Loss + Reading - Amp Factor
 2. The emission levels that are 20dB below the official limit are not reported.

12.DEVIATION TO TEST SPECIFICATIONS

[NONE]