



## **i-Q350L RTLS AS**

RTLS Transponder – Screw Fixing

## **i-Q350L RTLS AH**

RTLS Transponder – Hook Fixing

## **User Manual**



# i-Q350L RTLS AS & i-Q350L RTLS AH USER MANUAL

## Proprietary Notice

This document contains confidential information proprietary to IDEN TEC SOLUTIONS and may not be used or disclosed to other parties in whole or in part without the prior written authorization from IDEN TEC SOLUTIONS.

## Disclaimer and Limitation of Liability

IDEN TEC SOLUTIONS AG and its affiliates, subsidiaries, officers, directors, employees and agents do not make any express or implied warranties or representations with respect to such information including, without limitation, warranties as to non-infringement, reliability, suitability for a particular purpose and accuracy. IDEN TEC SOLUTIONS shall not under any circumstances be liable to any person for any special, incidental, indirect or consequential damages, including without limitation, damages resulting from use of or reliance on information presented herein, or loss of profits or revenues or costs of replacement goods, even if informed in advance of the possibility of such damages.

## Trademarks

"IDEN TEC SOLUTIONS", "Intelligent Long Range", "ILR" and the stylized "i" are registered trademarks and "i-CARD", "i-PORT", "i-LINKS", "Visibility Delivered." are trademarks of IDEN TEC SOLUTIONS, Inc. and/or IDEN TEC SOLUTIONS AG.

## Copyright Notice

Copyright © 2016 IDEN TEC SOLUTIONS. All rights reserved.

No part of this document may be reproduced or transmitted in any form by any means, photographic, electronic, mechanical or otherwise, or used in any information storage and retrieval system, without the prior written permission of IDEN TEC SOLUTIONS.

Issue 1.4 / April 2017 (MOM)

Subject to alteration without prior notice.

© Copyright IDEN TEC SOLUTIONS 2017

Printed in Austria

## Contact us

### EUROPE

+43 5577 87387-0  
sales@identecolutions.com

### NORTH AMERICA

+1 972 535-4144  
sales@identecolutions.com

### HEAD OFFICE

IDEN TEC SOLUTIONS AG  
Millennium Park 2  
6890 Lustenau  
Austria  
Tel. +43 5577 87387 0  
Fax +49 5577 87387 15

### GERMANY

IDEN TEC SOLUTIONS  
DEUTSCHLAND GMBH  
AURUM 05 / Ost  
Goldbeckstraße 5  
69496 Hirschberg  
Germany  
Tel.: +49 (0)6201 9957-0  
Fax: +49 (0)6201 9957-99

### USA

IDEN TEC SOLUTIONS, INC.  
Preston Plaza, Suite 200,  
17950 Preston Rd.  
Dallas, Texas 75252  
USA  
Tel: (972) 535 4144  
Fax: (469) 424-0404

### NORWAY

IDEN TEC SOLUTIONS  
NORWAY AS  
Andøyfaret 15  
4623 Kristiansand  
Norway  
Tel. +47 38 00 35 30  
Fax +47 38 00 35 31

### AUSTRALIA

IDEN TEC SOLUTIONS  
AUSTRALIA AND NEW  
ZEALAND P/L  
Riverview Business Park 72  
Maribyrnong St, Footscray,  
3011 Australia  
Tel. +61 3 9396 8900  
Fax +61 3 9689 2493

MODEL:		i-Q350L RTLS AS & i-Q350L RTLS AH
Region/Country	Organization	Marking
EUROPE:	EC	CE
USA:	FCC	FCC ID: 004-ILR-IQ350LS
Canada:	Industry Canada	IC: 3538A-IQ350LS

The user(s) of these products are cautioned to only use accessories and peripherals approved, in advance, by IDENITEC SOLUTIONS. The use of accessories and peripherals, other than those approved by IDENITEC SOLUTIONS, or unauthorized changes to approved products, may void the compliance of these products and may result in the loss of the user(s) authority to operate the equipment.

## European Notification according to R&TTE Directive

It is tested for compliance with the following standards:

ETSI EN 301 489-1 (V1.9.2), ETSI EN 301 489-3 (V1.6.1), ETSI EN 301 489-17 (V2.2.1)  
ETSI EN 300 220-1 V2.4.1 (2012), ETSI EN 300 220-2 V2.4.1 (2012), ETSI EN 300 328 V1.9.1

EN 60950-1 (2006+A11/2009+A1/2010+A12/2011+A2/2013),  
IEC 60950-1 (2005+A1/2009+A2/2013), EN 62311 (2008)

## USA Notification

This device complies with part 15 of the FCC Rules. Operation is subject to the following two conditions:

- (1) This device may not cause harmful interference, and
- (2) this device must accept any interference received, including interference that may cause undesired operation.

## Canada Certification

This device complies with Industry Canada's license exempt RSS's. Operation is subject to the following two conditions:

- (1) This device may not cause harmful interference, and
- (2) this device must accept any interference received, including interference that may cause undesired operation.

Le présent appareil est conforme aux CNR d'Industrie Canada applicables aux appareils radio exempts de licence. L'exploitation est autorisée aux deux conditions suivantes:

- (1) l'appareil ne doit pas produire de brouillage, et
- (2) l'utilisateur de l'appareil doit accepter tout brouillage radioélectrique subi, même si le brouillage est susceptible d'en compromettre le fonctionnement.

## RF Exposure

To satisfy FCC and IC RF Exposure requirements for mobile devices, a separation distance of 20 cm or more should be maintained between the antenna of this device and persons during operation. To ensure compliance, operation at closer than this distance is not recommended. This transmitter must not be co-located or operating in conjunction with any other antenna or transmitter.

Pour satisfaire aux exigences FCC et IC concernant l'exposition aux champs RF pour les appareils mobiles, une distance de séparation de 20 cm ou plus doit être maintenu entre l'antenne de ce dispositif et les personnes pendant le fonctionnement. Pour assurer la conformité, il est déconseillé d'utiliser cet équipement à une distance inférieure. Cet émetteur ne doit pas être co-situé ou fonctionner conjointement avec une autre antenne ou un autre émetteur.



This product contains components that are sensitive to electrostatic discharges. Please observe the special instructions for their protection. Incorrect handling can damage the unit and cause the invalidation of the warranty.

### **Minimum safety precautions against electrostatic discharge:**

- Establish earth contact before you touch the unit. (For example, touch the earthing screw on the unit.) Best practice is to use an antistatic ribbon and earth yourself permanently for the time you handle the unit.
- Avoid unnecessary contact with the unit connectors and assemblies inside the unit.
- Only open the unit if the operational settings (as described in the manual) expressly requires it.
- Use antistatic tools for the setting of the unit. (Warning: Do not touch life-threatening voltages with these tools).
- Do not store unit and components without protective packaging.
- Remove unit and components from the packaging only prior to installation.

**These notes are not sufficient to guarantee complete protection from electrostatic discharges! We recommend the use of suitable protective equipment.**

## Contents

<b>1. PREFACE</b> .....	<b>8</b>
1.1. PREPARATIONS.....	8
1.2. SCOPE OF THIS DOCUMENT .....	8
1.3. RESPONSIBILITY .....	8
1.4. UPDATES .....	8
1.5. SCOPE OF DELIVERY—VISUAL INSPECTION.....	8
1.6. ASSOCIATED DOCUMENTS .....	8
<b>2. INTRODUCTION</b> .....	<b>9</b>
2.1. FUNDAMENTALS.....	9
2.2. COMPONENT OVERVIEW .....	9
2.3. SYSTEM COMPONENTS – TRANSPONDERS.....	10
2.3.1. i-Q350 Transponders.....	10
2.3.2. Polarization of Transponders.....	10
2.4. SYSTEM COMPONENTS – READERS .....	11
2.4.1. i-Port-M350-2 .....	11
2.4.2. i-Port-BT-USB .....	11
<b>3. TRANSPONDER MOUNTING TECHNIQUES</b> .....	<b>12</b>
3.1. CABLE STRAPS .....	12
3.2. RIVETS .....	12
3.3. SCREWS .....	13
<b>4. CONFIGURATION OF THE TRANSPONDER</b> .....	<b>14</b>
4.1. GENERAL .....	14
4.2. PING RATE.....	16
4.3. BURSTS WHEN PASSING A POSITION MARKER .....	16
4.4. BURSTS TRIGGERED BY THE PUSH BUTTON .....	16
4.5. LIMITATIONS OF THE USER DATA FIELD.....	17
4.6. RTLS SETTINGS.....	17
4.7. MOTION SENSOR SETTINGS.....	19
4.8. INFORMATION ON BURST SETTINGS FOR THE MARKER.....	21
4.9. INFORMATION ON BURST SETTINGS FOR THE PUSH BUTTON .....	22
<b>5. TROUBLESHOOTING</b> .....	<b>23</b>
5.1. GENERAL .....	23
<b>6. MAINTENANCE</b> .....	<b>24</b>
6.1. GENERAL .....	24
6.2. REGULAR CLEANING OF THE HOUSING SURFACE .....	24
6.3. PRECAUTIONARY MAINTENANCE.....	24
6.4. RETURNS.....	24
6.5. BATTERY EXCHANGE .....	25
<b>7. TECHNICAL DATA</b> .....	<b>26</b>



# i-Q350L RTLS AS & i-Q350L RTLS AH USER MANUAL

## **Safety Instructions**

The system described in this manual is for exclusive operation of trained employees. Only qualified personnel that have knowledge of the potential dangers involved should perform the installation, settings, maintenance and repair of the units used.

## **Operational Safety**

The correct and safe use of these systems assumes that operating and service personnel follow the safety measures described in the manual alongside the generally acceptable safety procedures. If there is a possibility that safe operations cannot be guaranteed, the system must be switched off, secured against accidental use and the service unit responsible immediately informed.

## **Safety Documents**

The i-Q350L RTLS AS/AH was designed, tested and supplied in perfect condition according to document IEC348 Safety Requirements for Electronic Units of Class 1.

## **Condensate / Change of Temperature**

To avoid condensation in the system, the unit must be allowed to slowly adjust itself to warmer temperatures after removal from cold and cool environments.

## **Do not open the housing**

There is no need to open the housing during setup. Configuration is done with built in interface wirelessly. The only exception is for battery exchange.

## **Battery Inside**

All system Transponders contain a battery; therefore, the following warning should be heeded;

Warning  
Fire, explosion and burn hazard  
Risk of explosion if battery is replaced by an incorrect type  
Do not recharge, short circuit, crush, disassemble, heat above 100 °C (212 °F)  
Do not incinerate, or expose contents to water

## **Spare Parts**

We recommend that only personnel, original products, spare and replacement parts authorized by IDENTEC SOLUTIONS be used for installation, service and repair. IDENTEC SOLUTIONS does not accept any responsibility for materials used, work carried out or possible consequences from unauthorized third party vendors.

## **Electrostatic Discharge**

Semi-conductors of the type MOS or CMOS as well as two-pin types and precision resistance are sensitive to ESD. All components, printed circuit boards and auxiliary systems should therefore always be classed as sensitive to electrostatic discharge.

Before opening the cover, the unit should be placed onto an ESD-protected surface. As with all work on modern electronic modules, the use of ESD clamps and ESD mats during work on the unit is recommended.

- Sufficiently protect all printed circuit boards that were removed from the unit from damage.
- Observe all normal precautions for the use of tools.
- Use ESD-protected packaging material.

Never use measuring units with low impedance for measuring or testing systems with semi-conductor components. Never use high voltage testing units or dielectric test units to test systems with semi-conductor components.

If it is necessary to check the isolating properties of the field wiring, the assemblies (electronic units and transponders) should be disconnected.

Earth the test units.

IDENTEC SOLUTIONS does not accept the return of products where the regulations concerning the ESD precautions and protective packaging materials were not followed.

ESD – Electrostatic Discharge

EMC – Electromagnetic Compatibility

SELV – Safety Extra Low Voltage – Protective measure against dangerous body currents, formerly: protective first voltage range



# i-Q350L RTLS AS & i-Q350L RTLS AH USER MANUAL

## 1. PREFACE

### 1.1. Preparations

This installation manual must be read carefully prior to starting the installation. The described installation works, assuming that installation materials like cable, antenna and mounting materials are available.

### 1.2. Scope of This Document

This document is the hardware description of the i-Q350L RTLS AS/AH. This document is intended only for mechanical and electrical installation of these central units.

### 1.3. Responsibility

IDENTEC SOLUTIONS reserves the right to make changes and updates to the content contained herein. It is the user's responsibility to contact the service department for any possible changes or updates to operating and maintenance procedures.

### 1.4. Updates

Updates will be provided upon request. The information in this document may be subjected to changes without prior notice.

### 1.5. Scope of Delivery—Visual Inspection

Check whether delivery is complete and for any damages. If the delivery is not complete or damaged immediately inform the carrier. The dispatch and service organization of IDENTEC SOLUTIONS should also be informed to facilitate the repair or exchange of the system.

### 1.6. Associated Documents

#### **Software description and Programmer's Guide**

- SDK Online Help
- i-SHARE Manual
- Specific transponder manuals
- Reader manuals



## 2. INTRODUCTION

### 2.1. Fundamentals

The IDEN TEC SOLUTIONS' SensorSMART Platform is the latest development in asset management, localization and process optimization. Developed to deliver the last mile in industrial communication, the SensorSMART Platform fulfills a niche not previously addressed by available networks.

The SensorSMART Platform takes the complexity out of managing assets, personnel safety monitoring and/or the tracking of valuable cargo and the need for multiple technologies. The unique combination of active RFID, RTLS and WSN in one platform eliminates the necessity for complex deployments of multiple technologies, or the need to compromise with one technology's specific functionalities. The pinnacle of the SensorSMART Platform is that it captures the best of RFID, WSN, and RTLS while also avoiding the less desirable features of each technology. Third party application development is also simplified for added flexibility.

### 2.2. Component Overview

#### SensorSMART Platform

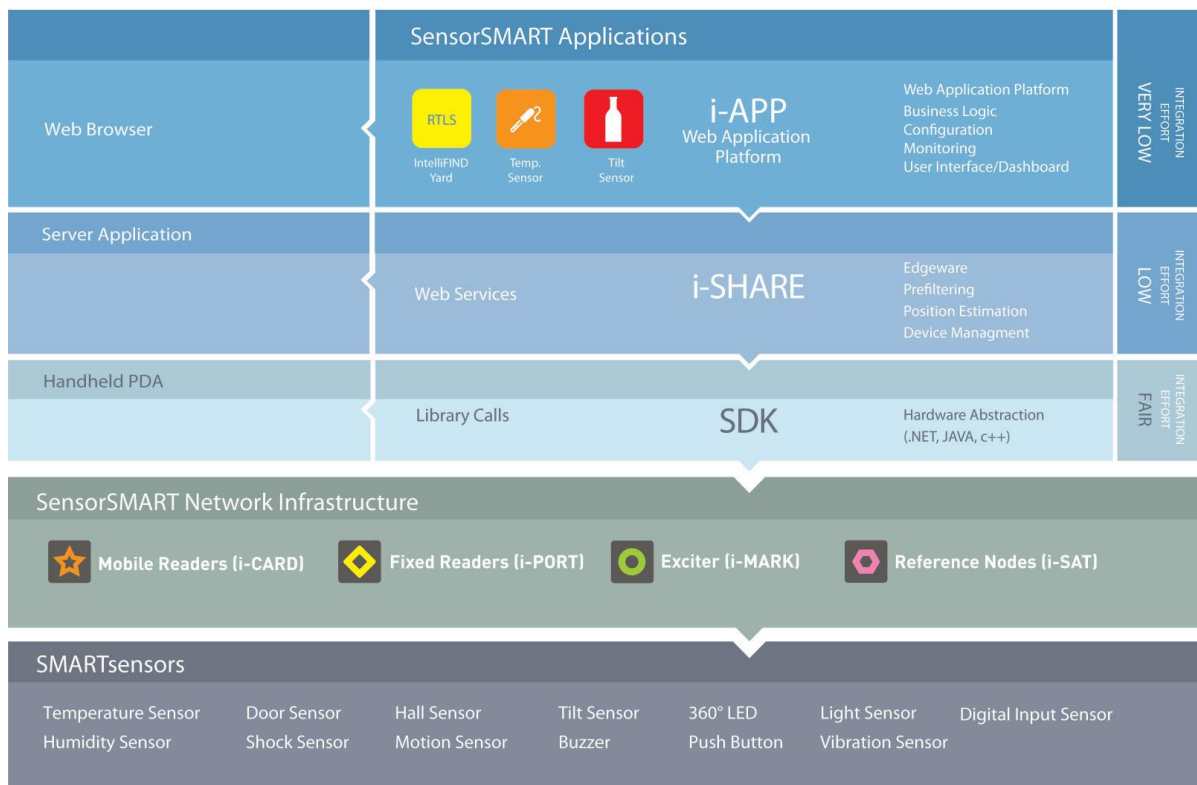

## 2.3. System Components – Transponders

### 2.3.1. i-Q350 Transponders

IDEN TEC SOLUTIONS' Real Time Locating System (RTLS) allows long-range localization in both indoor and out- door environments. Highly robust and value driven, the SensorSMART RTLS is designed to offer maximum reliability and functionality.

Highly accurate, the RTLS enables real-time data collection and visibility with minimal human intervention. IDEN TEC SOLUTIONS' RTLS is well suited for a variety of wireless applications including:

- Identification
- Tracking
- Localization of high value assets and personnel.

The high speed localization delivers instant identification as well as the precise location of assets or personnel within a 1m (3ft) radius.

Easy to integrate, the RTLS system has a rugged design that delivers outstanding performance even in the most challenging industrial environments.

The i-Q350L RTLS in conjunction with the i-SAT 300 RTLS reference generator allows communication even with rapidly-moving Transponders.

### 2.3.2. Polarization of Transponders

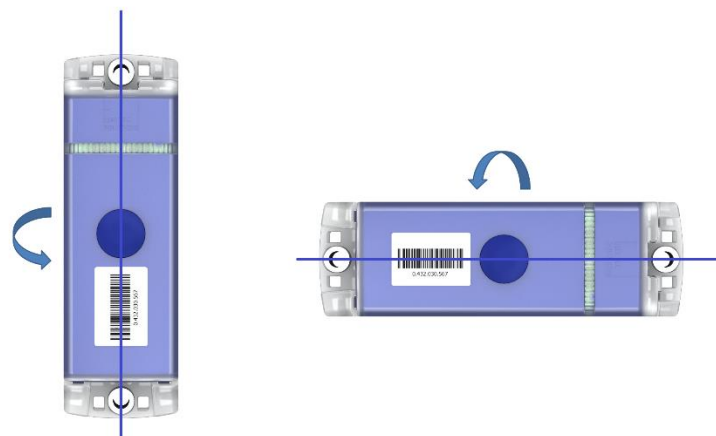

Vertically Polarized

Horizontally Polarized

Polarization is dependent on orientation and is rotation symmetrical.

## 2.4. System Components – Readers

### 2.4.1. i-Port-M350-2



The i-PORT M350-2 is a reader for the i-Q350 and i-B350 series of IDEN TEC SOLUTIONS's Response and Broadcast Transponders. Built into a compact housing, the i-PORT M350-2 reads and writes data to the transponders at distances of up to 500 meters (1640 feet) on two antennas. Connection to the host system is established via a RS422 interface, resulting in the capability to connect up to 8 readers in a Daisy Chain using commercially available CAT 5 cables and connectors.

A simple master/slave protocol enables data exchange. Not only does the protocol contain the data received from the transponder, but it can also provide information about the time of data reception, field strength and information about the number of times the transponder has been received by the reader.

### 2.4.2. i-Port-BT-USB



The battery powered mobile reader with Bluetooth and USB interface communicates with a wide spectrum of handheld devices and tablet computers. It is ideally suited for mobile applications such as laydown yards and personnel safety.

With its integrated Bluetooth interface, the mobile reader can communicate with a wide range of mobile devices independent of platform or operating system.

The compact and robust housing with internal antenna is designed to be mounted onto a handheld device or a tablet computer. The small form factor also allows users to carry the reader in a pocket.

## 3. TRANSPONDER MOUNTING TECHNIQUES

The Transponder can be mounted either with cable straps using the 2 slots at each end, by using rivets or screws described in the following 3 subchapters.

### 3.1. Cable Straps



### 3.2. Rivets

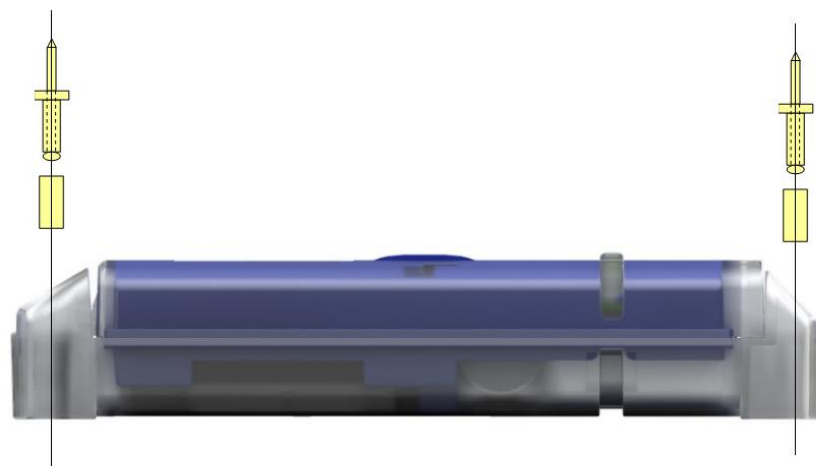

## 3.3. Screws



## 4. CONFIGURATION OF THE TRANSPONDER

### 4.1. General

The i-Q350L RTLS AS/AH is not configured directly. It is configured wirelessly using an ILR GEN3 compatible device, e.g. an i-PORT M350 or i-Port-USB-BT

#### Things to be configured

- Beacon ping rate (It is recommended to set it at more than 20 seconds. In case there are more than 500 Transponders in the antenna field it is recommended to set it at more than 60 seconds)
- Monitoring data:
  - Monitoring interval (15 min to 2 hours, in steps of 1 minute)
  - Data to be monitored

#### Important Note

Do not open the housing! Configuration is done wirelessly.

The Response mode of the i-Q350L RTLS AS/AH offers the following features for configuration:

- Broadcast mode can be configured for simultaneous operation. In this case the Transponder responds to commands from a reader as well as broadcasting configurable data at a regular interval.
- Marker technology for locating the Transponder in an inductive loop and measuring travel time between gates.
- Bursts triggered by a marker field can be configured independent of regular broadcast pings.
- Bursts triggered by the push button can be configured independent of regular broadcast pings.

#### Tools Needed

- PC running Microsoft Windows, with SensorSMART Tools installed
- Connection to an i-PORT-M350 or i-Port-BT-USB, to communicate with the Transponders

## Overview on the Configuration Software

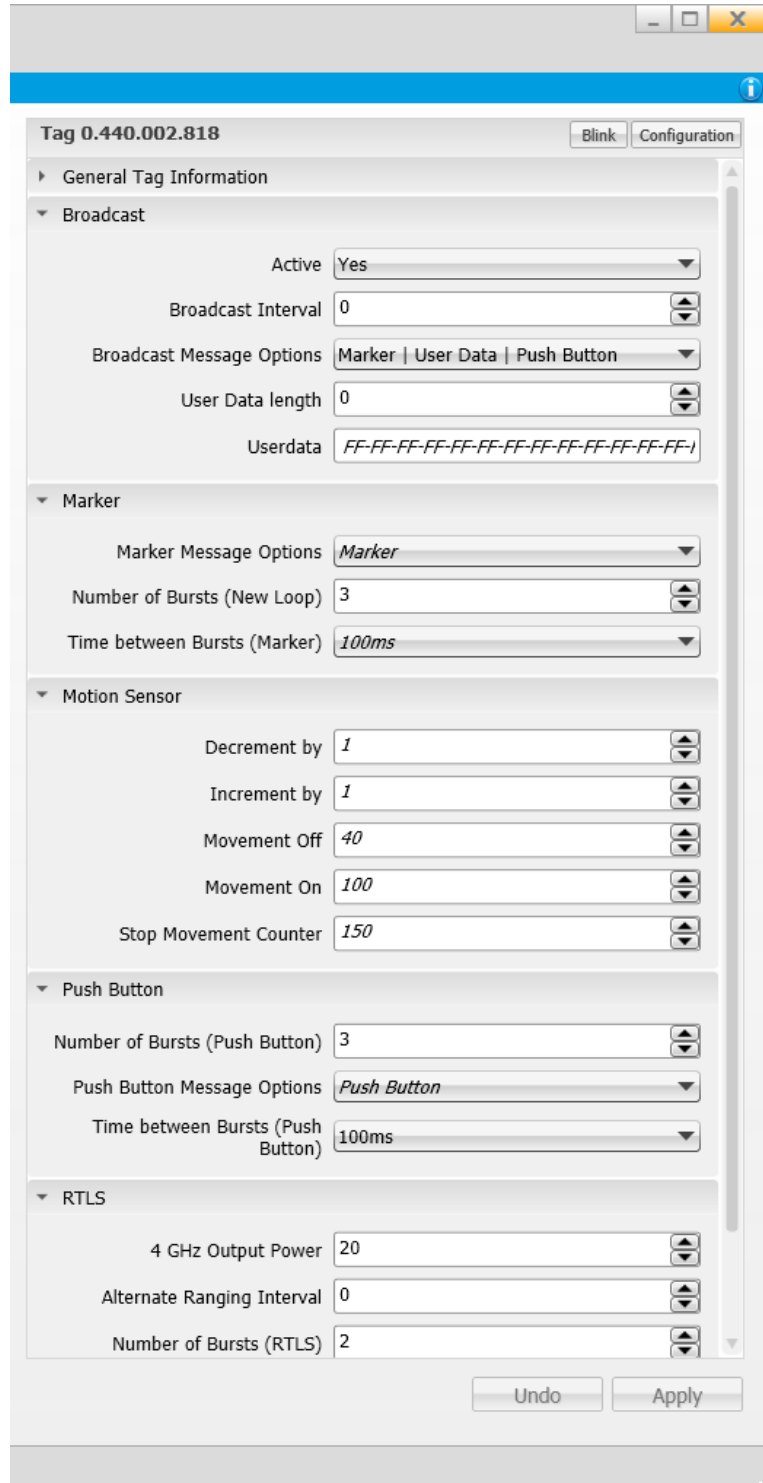

The screenshot displays the configuration software interface for a specific tag, identified as "Tag 0.440.002.818". The interface is organized into several sections, each with a dropdown arrow on the left:

- General Tag Information:** Includes a "Blink" button and a "Configuration" tab.
- Broadcast:**
  - Active: Yes
  - Broadcast Interval: 0
  - Broadcast Message Options: Marker | User Data | Push Button
  - User Data length: 0
  - Userdata: FF-FF-FF-FF-FF-FF-FF-FF-FF-FF-FF-FF-FF-FF-FF-FF-FF-FF-FF-FF-FF-FF
- Marker:**
  - Marker Message Options: Marker
  - Number of Bursts (New Loop): 3
  - Time between Bursts (Marker): 100ms
- Motion Sensor:**
  - Decrement by: 1
  - Increment by: 1
  - Movement Off: 40
  - Movement On: 100
  - Stop Movement Counter: 150
- Push Button:**
  - Number of Bursts (Push Button): 3
  - Push Button Message Options: Push Button
  - Time between Bursts (Push Button): 100ms
- RTLS:**
  - 4 GHz Output Power: 20
  - Alternate Ranging Interval: 0
  - Number of Bursts (RTLS): 2

At the bottom of the configuration window, there are "Undo" and "Apply" buttons.

## 4.2. Ping Rate

Note: These settings can be found in the ILR Tag Configuration software tool in the section "Broadcast"

- Active: Activates or de-activates the broadcast function that regularly sends out messages.
- Broadcast Interval: 0 = no broadcast messages are sent, value > 0 = Broadcast interval in seconds. This can be set in steps of 0.5 sec, from 0.5 sec up to 300 sec.
- Broadcast Message Options: The options in this field depend on the capabilities of the Transponder. The subchapter "Limitations of the User Data Field" lists the possible options of this Transponder type.
- User Data Length: Configure the number of Bytes from the "User Data" that is sent with a broadcast message. The number starts from Byte 0 (zero). The limits of the User Data length are described at the end of this chapter.

## 4.3. Bursts when passing a Position Marker

Note: These settings can be found in the ILR Tag Configuration software tool in the section "Marker"

- Number of Bursts (New Loop): 0 = no bursts, max. 15 bursts
- Time between Bursts (Marker): This sets a timeslot inside which the Transponder sends out a single burst. This gives a random delay between every single burst message to avoid collisions with Transponders that are triggered by the same source to burst. Possible settings are 40, 100, 200, 300, 400, 500, 600, and 700 ms. Pls. read the details in the following subchapter "Information on Burst Settings".
- Marker Message Options: Entering a marker field triggers a burst. This parameter determines the contents of the burst messages.

## 4.4. Bursts triggered by the Push Button

Note: These settings can be found in the ILR Tag Configuration software tool in the section "Push Button"

- Number of Bursts (Push Button): 0 = no bursts, max. 15 bursts
- Time between Bursts (Push Button): This sets a timeslot within the Transponder sends a single burst. This gives a random delay between every single burst message to avoid collisions with Transponders that are triggered by the same source to burst. Possible settings are 100, 200, 300, 400, 500, 600, and 700 ms. Please read the details in the following subchapter "Information on Burst Settings".
- Push Button Message Options: Pushing the button triggers a burst. This parameter determines the contents of the burst messages.



## 4.5. Limitations of the User Data Field

The total length of the broadcast message (burst or ping) is limited to 50 Bytes. Depending on the broadcast message options, these are the allowed number of bytes for the user data:

Message Type	Length of User Data
User Data only	max. 50 Bytes
Marker   User Data	max. 38 Bytes
Push Button   User Data	max. 43 Bytes
Push Button   User Data   Marker	max. 32 Bytes

## 4.6. RTLS Settings

Note: These settings can be found in the ILR Tag Configuration software tool in the edit block "RTLS"

The RTLS Transponder allows precise location calculation by ranging to up to 15 reference nodes (i-SAT 300, i-PORT M 350 RTLS) at the same time. By default, this is done at an interval set by the parameter "Ranging Interval". In addition, the RTLS Transponders contain a motion sensor with a software filter (see next subchapter) that switches between standard and alternate ranging intervals. This is set with the parameters "Ranging Behavior", "Ranging Interval" and "Alternate Ranging Interval". Ranging describes the process used to measure the distance between a Transponder and a reader through the exchange of a specific set of messages. A ranging can be initiated based on time (interval) or event (motion or application request).

Adjustable parameters in the section "RTLS" are:

- **2.4 GHz Output Power:** This is the Tx power for the RTLS ranging. Increasing the output power will greatly impact the communication range, but also have a massive impact on the power consumption. The following table shows the power consumption during a transmission depending on the output power.

Output power in dBm	Power consumption increase compared to 0 dBm	Estimated range*
0	0 %	40 m
10	9 %	170 m

\* Estimated range in outdoor operation and in line of sight

- **Ranging Behavior:**

The ranging process consists of multiple bidirectional communications, in order to calculate the distance between the Transponder and the reader. i-Q350L RTLS Transponders are able to identify if they are in motion or stand still. In the case of movement, the Transponder will switch to the "in motion" behavior and use the alternate ranging interval. Two behaviors are available and described hereafter.

### Continuous ranging behavior:

While in motion, the i-Q350L RTLS Transponder will perform ranging using the interval specified in "alternate ranging interval". After the Transponder detects that it has stopped moving, it will perform ranging using the standard ranging interval.

The following figure represents the behavior of the Transponder over time. The ranging is in orange, while the bursts on RTLS event are in blue. This example shows 3 UHF bursts.

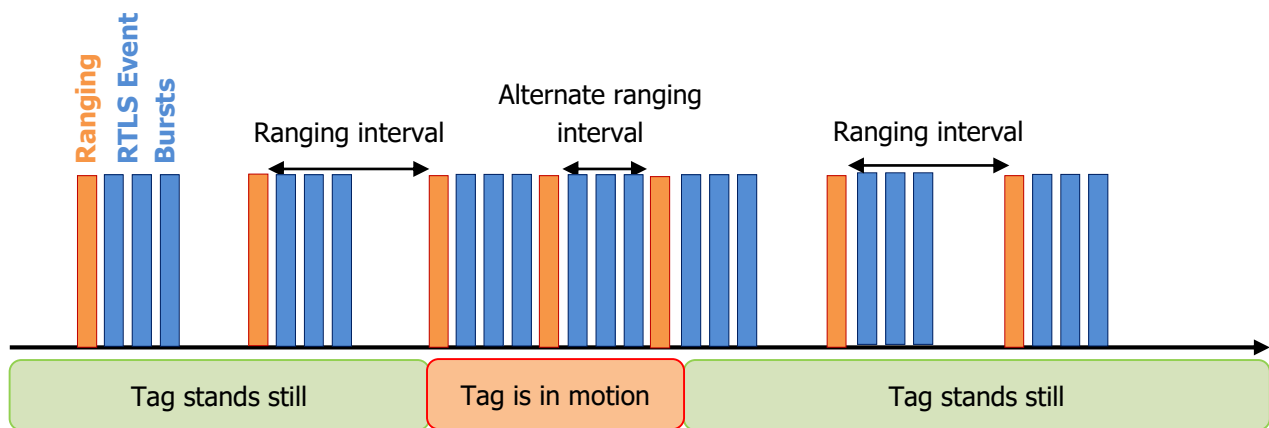

In this mode, the Transponder will broadcast distances measured after the ranging is done. As soon as the Transponder considers it has stopped moving, it resumes its standard behavior.

### On Stop ranging behavior:

The i-Q350L RTLS Transponder will keep its standard ranging interval while moving. As soon as the i-Q350L RTLS detects that it has stopped moving, it will perform 6 measurements with the interval specified in the "alternate ranging interval".

The following figure represents the behavior of the Transponder over time. The ranging is in orange, while the bursts on RTLS event are in blue. This example shows 3 UHF bursts.

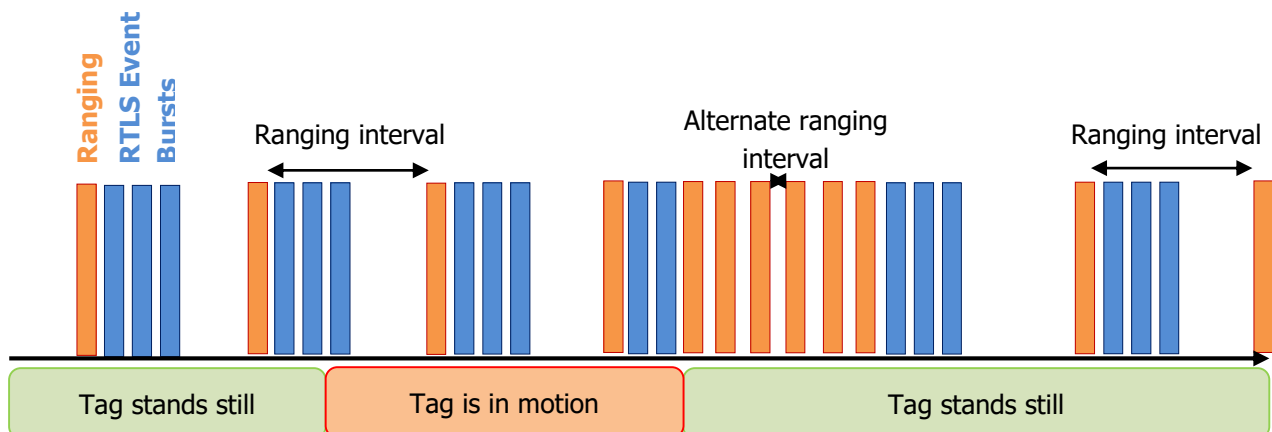

In this mode, the Transponder will broadcast its distance measured, only after the 6 ranging intervals are done. In order to save the amount of data transmitted, the Transponder will send only the smallest distance measured with each reader or i-SAT. As soon as the Transponder considers it has stopped moving, it resumes its standard behavior.

- **Ranging Interval:** This sets the standard ranging interval, which the Transponder performs constantly. This can be set in steps of seconds from 1 second up to 4 hours 39 minutes. The default value is 5 minutes.
- **Alternate Ranging Interval:** This sets the faster ranging interval, triggered by the motion sensor. This can be set in steps of seconds from 1 second up to 4 hours 39 minutes. The default value is 10 seconds.

## Classic Use Cases

Case	Ranging interval	Alternate ranging interval	In motion behavior
Localization on fix interval only	Application dependent	0	0 (on stop)
Localization on fix interval and different interval when moving	Application dependent	Application dependent	1 (continuous)
Localization on fix interval and fast positioning when stopping	Application dependent	Application dependent	0 (on stop)
Localization only when moving	0	Application dependent	1 (continuous)
Localization only when stopping	0	Application dependent	0 (on stop)
Do not perform localization	0	0	0 (on stop)

## 4.7. Motion Sensor Settings

Note: These settings can be found in the ILR Tag Configuration software tool in the edit block "Motion Sensor"

- *Stop Movement Counter:* Maximum value of the motion counter. If this value is reached, the counter stops increasing. Range: 0 to 65534 (default: 150)
- *Movement On:* Threshold at which the Transponder is considered to be in motion. Typically, this is the upper value. Range: 0 to 65534 (default: 100)
- *Movement Off:* Threshold at which the Transponder is considered to remain in its place. Typically, this is the lower value. Range: 0 to 65534 (default: 40)
- *Increment by:* Rate of increase of the movement counter. Range: 1 to 254 (default: 1)
- *Decrement by:* Rate of decrease of the movement counter. Range: 1 to 254 (default: 1)

The Transponder contains a motion sensor that is interrogated every 100 ms. If motion is detected, the movement counter is increased. If no motion is detected the movement counter is decreased. If the value of the movement counter reaches the threshold value "Movement On", the Transponder can switch its ranging status from "On Stop" to "Default" or vice versa according to the setting "Ranging Behavior". If the value of the movement counter drops below the threshold value "Movement Off" the ranging behavior is switched again.

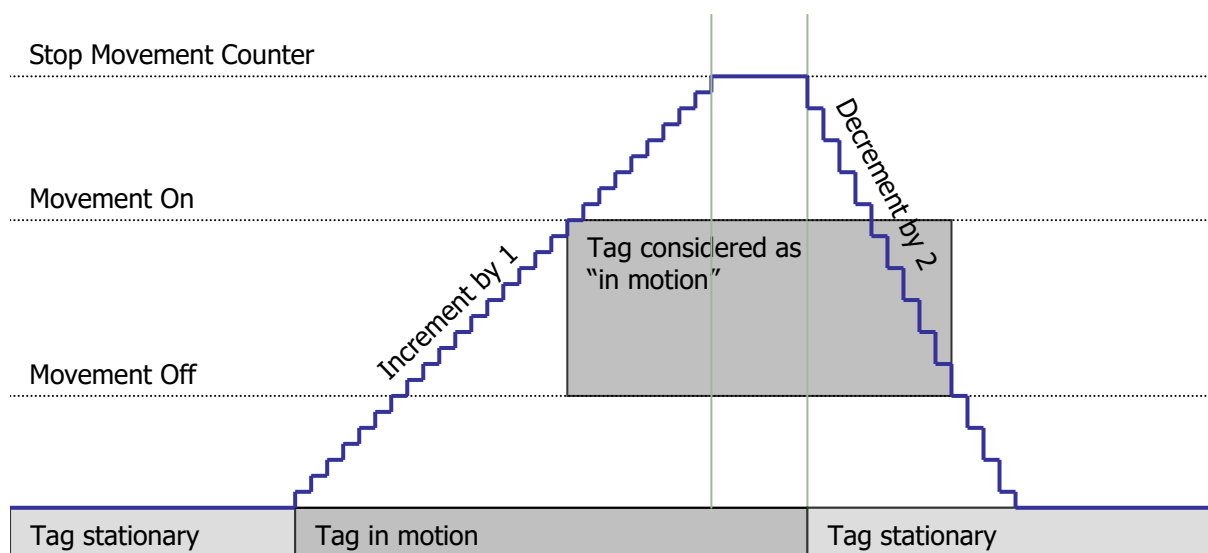

So by adjusting these 5 parameters of the movement counter, short-term influences can be eliminated.

### Classic Use Cases

Behavior	Top movement Counter	Movement On	Movement Off
Standard	Application dependent	Application dependent	Application dependent
Transponder never reports movement	Top movement Counter > Movement Off	Movement On > Top movement Counter	0
Transponder always report movement	Top counter > Movement On	0	Movement Off > Top counter
<b>ILLEGAL</b>	<b>0</b>	<b>0</b>	<b>0</b>

## 4.8. Information on Burst Settings for the Marker

The parameter "Time between Bursts (Marker)" is not simply a delay time. It is in fact a timeslot. In this timeslot, the Transponder chooses a random moment to do a single burst. This avoids that burst collisions with other Transponders, that are simultaneously triggered by the same marker loop. These timeslots are repeated until all bursts are sent.

In the event that dozens of Transponders are triggered to burst at once, this value can be increased. The result of increasing the slot width is there will be a longer time interval between other bursts being sent. For example, with an increased value of 700 ms and 8 bursts, the amount of time for all bursts is 5.6 seconds.

### Example

This example shows 3 Transponders (A, B, C) that are simultaneously triggered by a marker loop (LF marker) and are configured to burst 3 times. The timeslot (Time between Bursts) is set to the default value of 40 ms.

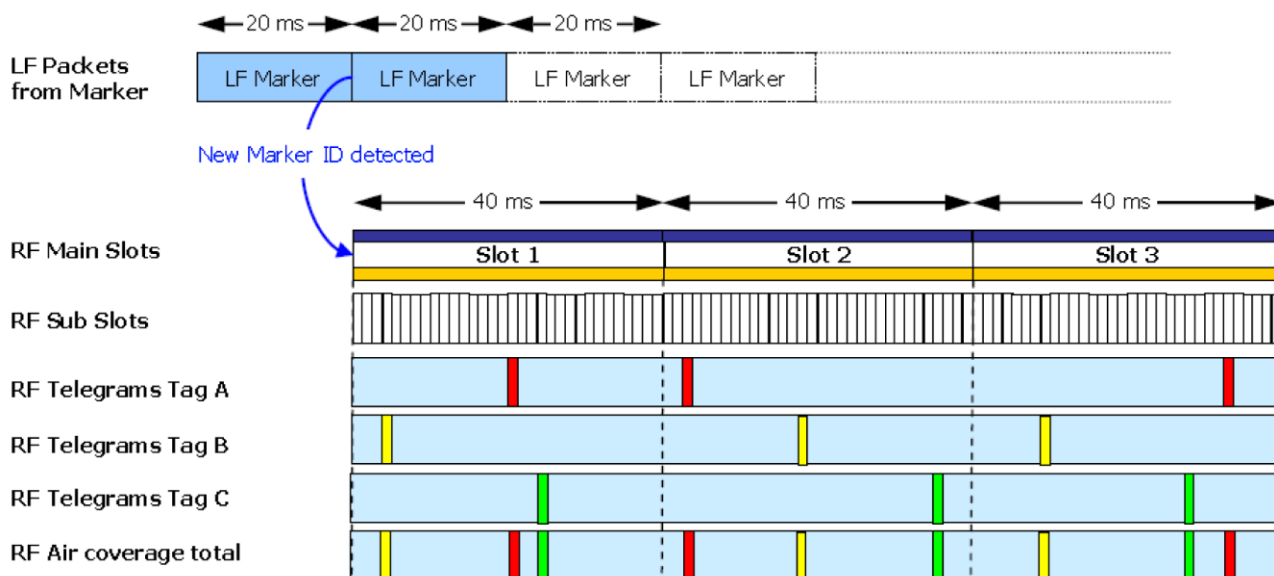

The last row shows how the random use of the timeslot avoids collision between the Transponders.

## 4.9. Information on Burst Settings for the Push Button

The parameter "Time between Bursts (Push Button)" is not simply a delay time. It is in fact a timeslot. In this timeslot, the Transponder chooses a random moment to do a single burst. This avoids that burst collisions with other Transponders, that are simultaneously triggered by the same marker loop. These timeslots are repeated until all bursts are sent.

In the event that dozens of Transponders are triggered to burst at once, this value can be increased. The result of increasing the slot width is there will be a longer time interval between other bursts being sent. For example, with an increased value of 700 ms and 8 bursts, the amount of time for all bursts is 5.6 seconds.

### Example

This example shows 3 Transponders (A, B, C) that are simultaneously triggered by a marker loop (LF marker) and are configured to burst 3 times. The timeslot (Time between Bursts) is set to the default value of 100 ms.

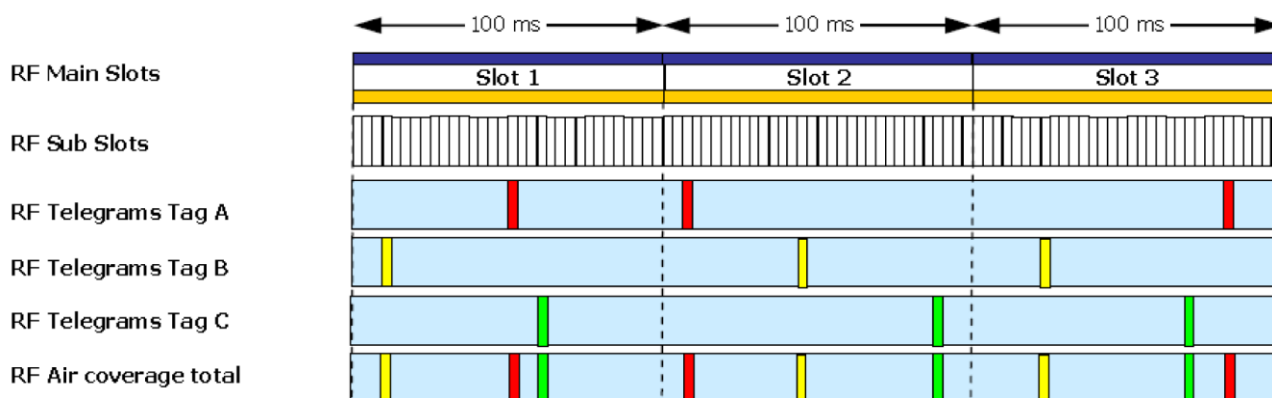

## 5. TROUBLESHOOTING

### 5.1. General

This chapter covers how faults can be recognized and rectified. There are potentially four main problem sources:

- The user control system, including task requirements, communication cables, peripheral units with possible object recognition switches.
- The SensorSMART platform, including peripheral units and their cables, also potential object recognition switches.
- The environment, including large objects between antenna and Transponder electrical disturbance sources, intervention by persons, etc.
- The quality of the technical design, including alignment between antenna, data, ratio of task requirements/available communication time etc. The information about system performance is contained in the relevant datasheets.

When planning the total system, do not overlook the problem sources and "Fault finding procedures on system level" should be included in the host system. How this could look in detail depends on the relevant system concept and very likely varies from one system to another.

## 6. MAINTENANCE

### 6.1. General

When installed correctly, the ILR System will operate virtually maintenance free for many years. However, in the event maintenance is required, only trained and authorized personnel are permitted to perform the updates, make changes and perform any necessary maintenance.

### 6.2. Regular cleaning of the Housing Surface

Remove dust with a brush or compressed air. If there are fatty or oily substances, use a soft cloth moistened with a mild rinsing agent.

#### **Warning**

Do not clean the Transponder in a dishwasher. Do not sandblast the Transponder. Do not use a high pressure water jet or steam cleaner. Do not use cleaning products containing chemical additives.

### 6.3. Precautionary Maintenance

A regular check of the system is recommended. Unstable connections could lead to damage and malfunctions of the system and would therefore need to be repaired as soon as possible.

#### **A Brief Checklist**

- Are all housings intact?
- Are all cables intact?
- Are all connectors intact?
- Are all connectors securely fastened?
- Are all screws still tight?
- Is there a malfunction in a specific unit?

### 6.4. Returns

Parts or main components returned for repair or exchange must be handled with great care. All returns should include an error description and a short application overview and be sent to the local distributor or to:

IDEN TEC SOLUTIONS AG  
Service Department  
Millenium Park 2  
6890 Lustenau  
AUSTRIA



## 6.5. Battery Exchange

### Tools Needed

- RTLS Housing battery compartment removal key
- Replacement Battery Pack for i-Q350L RTLS (455791)
- **WARNING: Batteries only to be replaced by qualified Personnel with correct tools**

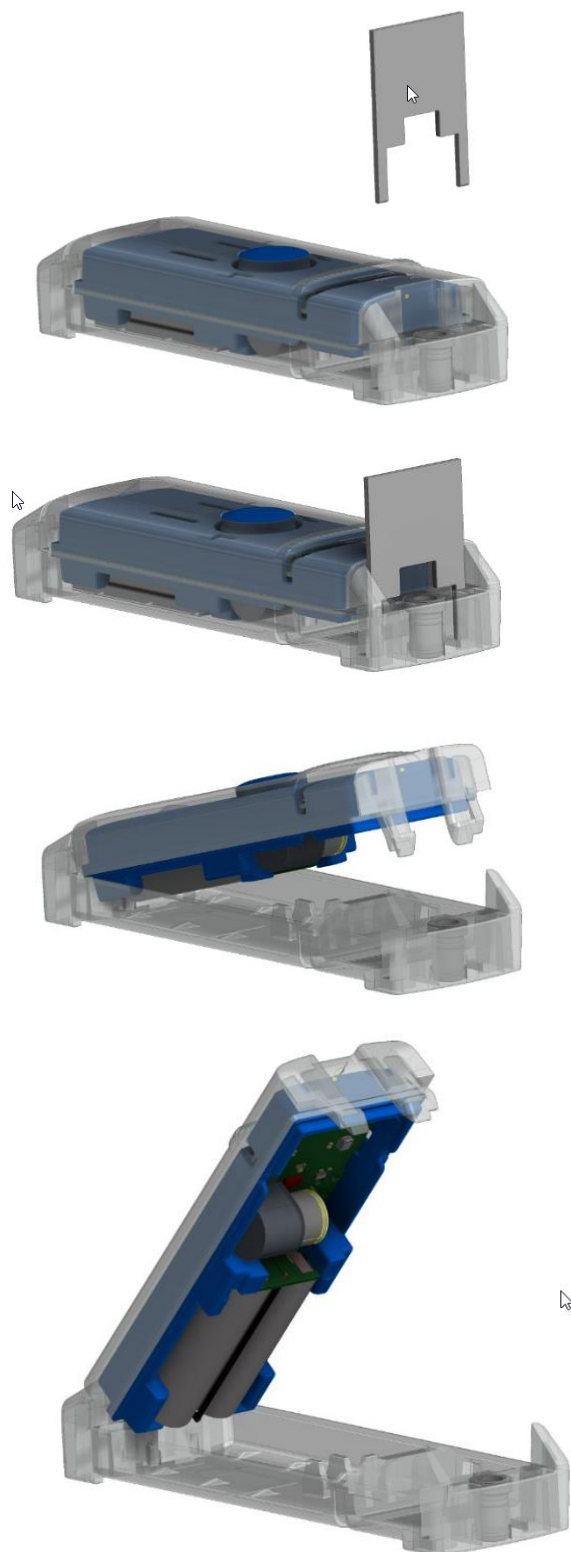

### Open the Housing/Battery Compartment

- Insert tool into designated slots on the Transponder

- Push down carefully to release the front of the Transponder housing from the back
- Warning: CAREFULLY take the Transponder in your hand

### Remove The Old Battery Pack

- Pull out the battery gently with fingers

### Place new battery pack in

- Place new battery pack in
- Check it is secure and in the correct direction

### Close housing

## 7. TECHNICAL DATA

### Communication Broadcast 350

Operation Mode	Transmits ID and user data in pre-defined interval
Read Range	up to 500m*
Compatibility	i-PORT M350, i-PORT-USB-BT
Operating Frequency	868 MHz (EU) or 920 MHz (NA) configurable
Transmit Power	<1mW (according to national regulations)

### Communication Response 350

Operation Mode	Bi-directional communication (wake up, read commands & respond)
Read Range	up to 250m*
Compatibility	i-PORT M350, i-PORT-USB-BT
Operating Frequency	868 MHz (EU) or 920 MHz (NA)
Transmit Power	<1mW (according to national regulations)

### Communication RTLS

Operation Mode	Distance Measurement, bidirectional
Read Range	up to 300m*
Compatibility	i-PORT M350 RTLS and i-SAT 300 RTLS
Operating Frequency	2.4 GHz
Transmit Power	<100 mW (according to national regulations)

### Communication Marker

Operation Mode	Receives Marker ID over LF and transmits information over UHF broadcast
Read Range	up to 5m (16ft)*
Compatibility	i-MARK-SR
Operating Frequency	125 kHz

### Data

Data Retention	> 10 years without power
Write Cycles	100,000 writes
Memory Size	10,000 Bytes user definable
Identification Code	48 bit fixed ID

### Configuration

Device	i-PROG M350L or i-PORT M350 or i-Port-USB-BT
Ping Rate	Configurable from 0.5 to 300 seconds in steps of 0.5 seconds
Number of Bursts	Configurable from 0 to 15
Broadcast User Data	Up to 50 Bytes

\*The communication range depends on the antenna type, antenna height, the antenna cable runs and the environmental conditions.



# i-Q350L RTLS AS & i-Q350L RTLS AH USER MANUAL

## Electrical

Power Source	Battery Pack (replaceable); 2x Lithium cells
Battery Monitoring	Yes

## Environmental Conditions

Operating Temperature	-20 °C to +85 °C (-4 °F to +185 °F)
Storage Temperature	-20 °C to +85 °C (-4 °F to +185 °F)
Humidity	10% to 95% relative humidity @ 30°C, non-condensing
Shock	EN 60068-2-32: Multiple drops to concrete from 1m (3ft), 5 times EN 60068-2-29: 50G on all 3 axis, 3 times per axis
Vibrations	EN 60068-2-6: 5G, 20 sin wave cycles per axis, 5-500Hz EN 60068-2-64: noise 5 to 1000Hz, 90 minutes per axis
Chemical	UV resistant for outdoor usage

## Standard/Certification

Europe	CE (EN 300 220-1, -3; EN 301 489-1,-3; EN 60950)
North America	FCC Part 15 (US); Industry Canada

## Mechanical Data

Dimensions	138.5 × 43.6 × 28.3 mm (5.45 × 1.72 × 1.11 inches)
Enclosure Material	Plastic
Enclosure Rating	IP 65
Weight	t.b.d

## Dimensional Drawing

### i-Q350L RTLS AS:

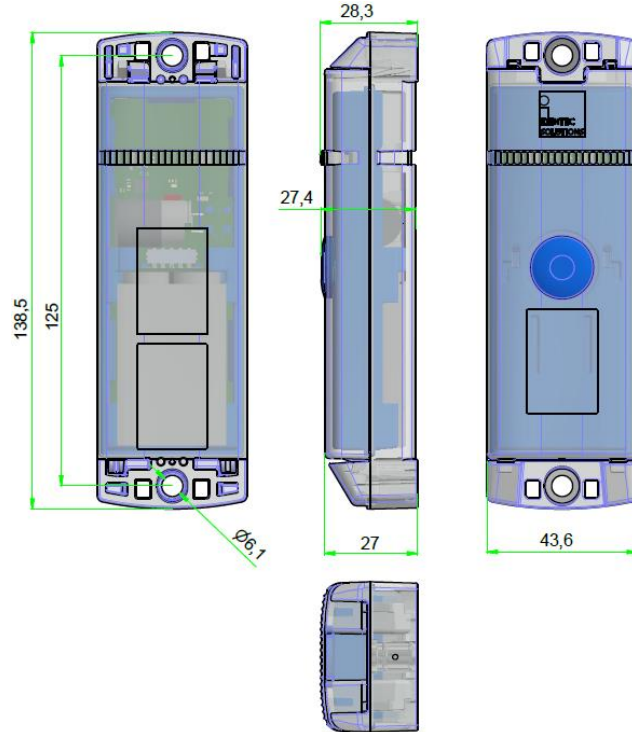

### i-Q350L RTLS AH:

