

TEST REPORT # EMCC-010133BC, 2002-12-13

EQUIPMENT UNDER TEST:

Trade Name:	i-CARD Interrogator
Model:	i-Card3
Serial No:	none
Equipment Category:	Transceiver
Manufacturer:	IDENITEC SOLUTIONS AG
Address:	Millennium Park 2 A-6890 Lustenau Austria
Phone:	+43-5577-87 387-0
Fax:	+43-5577-87 387-15 r.gantner@identecsolutions.at

RELEVANT STANDARD: 47 CFR Part 15.249

MEASUREMENT PROCEDURE USED:

ANSI C63.4-1992
 FCC/OET MP-4 (1987)
 Other

TEST REPORT PREPARED BY:

Wolfgang Döring
 EMCC DR. RAŠEK
 Moggast 72-74
 91320 Ebermannstadt
 Germany
 Phone: +49-9194-9016
 Fax: +49-9194-8125
 E-mail: w.doering@emcc.de

TEST PERSONNEL:

 Wolfgang Döring

HEAD OF LABORATORY:

 Winfried Hoffmann

EMCC DR. RAŠEK
 Moggast 72-74
 91320 Ebermannstadt
 Germany

FCC Registration # 90566

010133BC.doc

RADIO LABORATORIES
 EMC LABORATORIES



TTI-P-G 094/94
 TTI-P-G 074/95

Telephone: +49-9194-9016
 Telefax: +49-9194-8125
 Mail: emc.cons@emcc.de
 Web: http://www.emcc.de

TEST OF IDENTEC SOLUTIONS AG I-CARD INTERROGATOR MODEL I-CARD3 TO 47 CFR PART 15.249

CONTENTS	Page
1 GENERAL INFORMATION.....	3
1.1 Purpose.....	3
1.2 Limits and Reservations.....	3
1.3 Test Location.....	3
1.4 Manufacturer.....	3
1.5 Dates.....	3
2 PRODUCT DESCRIPTION.....	4
2.1 Equipment Under Test (EUT).....	4
2.2 EUT Peripherals.....	4
2.3 Mode of Operation During Testing.....	5
2.4 Modifications Required for Compliance.....	5
3 TEST RESULTS SUMMARY.....	6
4 ANTENNA REQUIREMENT.....	7
4.1 Regulation.....	7
4.2 Result.....	7
5 CONDUCTED EMISSIONS TESTS.....	8
5.1 Regulation.....	8
5.2 Test Equipment.....	8
5.3 Test Procedures.....	9
5.4 Test Results.....	9
6 RADIATED EMISSIONS.....	11
6.1 Regulation.....	11
6.2 Test Equipment.....	14
6.3 Test Procedures.....	14
6.4 Calculation of Field Strength Limits.....	15
6.5 Calculation of Average Correction Factor.....	15
6.6 Field Strength Calculation.....	15
6.7 Test Results.....	17
7 VARIATION OF OUTPUT POWER DUE TO INPUT VOLTAGE VARIATION.....	19
7.1 Regulation.....	19
7.2 Test Equipment.....	19
7.3 Test Procedure.....	19
7.4 Test Result.....	20
8 PRODUCT LABELING AND INFORMATION TO THE USER.....	21
8.1 Labeling.....	21
8.2 Information to the User.....	21
9 FURTHER PRODUCT INFORMATION.....	21
9.1 Theory of Operation.....	21
9.2 Block Diagram.....	21
9.3 Schematics, Parts Lists, Assembly Drawing.....	21
10 MISCELLANEOUS COMMENTS AND NOTES.....	22
11 LIST OF ANNEXES.....	22

1 GENERAL INFORMATION

1.1 Purpose

The purpose of this report is to show compliance to the FCC regulations for unlicensed devices operating under section 15.249 of the Code of Federal Regulations title 47. Furthermore the receiver part was investigated to the requirements of section 15.109.

1.2 Limits and Reservations

The test results in this report apply only to the particular Equipment Under Test (EUT) as declared in this report. This test report shall not be reproduced except in full without the written permission of EMCC DR. RAŠEK.

1.3 Test Location

Company Name: EMCC DR. RAŠEK
Street: Moggast 72-74
City: 91320 Ebermannstadt
Country: Germany
Laboratory: Test Laboratory of EMCC DR. RAŠEK
FCC Registration Number: 90566
This site has been fully described in a report submitted to the FCC, and accepted in the letter dated February 09, 2000 Registration Number 90566.
Phone: +49-9194-9016
Fax: +49-9194-8125
E-Mail: emc.cons@emailcc.de
Web: www.emcc.de

1.4 Manufacturer

Company Name: IDENTEC SOLUTIONS AG
Street: Millennium Park 2
City: A-6890 Lustenau
Country: Austria
Name for contact purposes: Mr. Reinhold Gantner
Phone: +43-5577-87 387-70
Fax: +43-5577-87 387-15
E-mail: r.gantner@identecsolutions.at

1.5 Dates

Date of receipt of EUT: CW 39/2002
Test date: CW 39 - 44/2002

2 PRODUCT DESCRIPTION

2.1 Equipment Under Test (EUT)

Trade Name:	i-CARD Interrogator
Model:	i-Card3
Serial Number:	none
FCC ID:	004-ILR-ICARD3
Application:	Interrogator for RF ID applications
Power:	5.0 V (external DC supply via PCMCIA or RS232 port)
Transmit Frequency:	916.50 MHz
Receive Frequency:	916.50 MHz
Internal clock frequencies:	19.68 MHz, 22.118 MHz
Antenna:	external, quarter wavelength monopole: IDENTEC SOLUTIONS P/N 887124
Interface ports:	Antenna port (MMCX female), PC-CARD (PCMCIA) (68 pin female socket), RS232 (15 pin mini)
Variants:	none
Remarks:	none

2.2 EUT Peripherals

The EUT was tested in 2 configurations: a) connected via the RS232 port to a remotely operated laptop PC and b) installed inside of a Compaq iPAQ Expansion Pack (Agency Series PE2036C). Additionally radiated tests performed also with a PCMCIA-Card Extender. The laptop PC with build-in PCMCIA Ethernet card was operated outside of the test environment. AC Line Conducted Emissions Test performed with the EUT installed inside of a Compaq iPAQ Expansion Pack powered by the supplied AC adapter. All tests in configuration a) performed powering the EUT by means of laboratory DC supply. Due to equipment failure (iPAQ Model 3630) all tests after 2002-10-04 continued with a replacement equipment (iPAQ Model 3760).

2.2.1 Pocket PC 1

Type: iPAQ Model 3630
Manufacturer: COMPAQ
Serial Number: 4G17DW3694FW
with Expansion Pack Agency Series PE2036C (S/N 4G1RJR73N013)

2.2.2 Pocket PC 2

Type: iPAQ Model 3760
Manufacturer: COMPAQ
Serial Number: 4G22DW38N02L
with Expansion Pack Agency Series PE2036C (S/N 4G24JR73G0AA)

TEST OF IDENTEC SOLUTIONS AG I-CARD INTERROGATOR MODEL I-CARD3 TO 47 CFR PART 15.249

2.2.3 AC Adapter for Pocket PC

Model: PSC10E-050
Manufacturer: PHIHONG

2.2.4 Notebook Computer (remotely operated)

Type: ARTIST (Maxdata)
Manufacturer: MAXDATA ETON
Serial Number: 60003960070

2.2.5 AC Adapter (for Notebook)

Type: SPN-260-19A
Manufacturer: MAXDATA ETON

2.3 Mode of Operation During Testing

The transceiver was tested in a test mode as provided from the manufacturer.

The transceiver settings/modes were controlled via the USB port and PCMCIA card port, respectively by the connected PC. For all control and communication functions the software "i-CARD3 Test Utility" was used.

Remark: The tested transceiver was capable to be aligned by the supplied test software also for operation in the European frequency bands f and i, respectively (according to ERC/REC 70-03 Annex 1).

These modes are not subject of this report. Equipment with such settings will not be distributed on the U.S. or Canadian market. The transceivers will be marketed in different versions (types) depending on the country/region where operation is intended. For details on setting predefined type specific parameters please refer to the description in Annex 5.

2.4 Modifications Required for Compliance

For compliance with the fundamental emissions limit the transmitter output power setting was reduced by about 3.5 dB to a setting of "Ucal Pwr = 4dBm" (resulting in a measured level at the antenna connector of: CW test mode: minus 4 dBm, normal operation mode: minus 6 dBm peak).

3 TEST RESULTS SUMMARY

Summary of Test Results for the following EUT: Manufacturer: **IDENTEC SOLUTIONS AG**
Device: **i-CARD Interrogator**
Model No.: **i-Card3**
Serial Number: **none**

Requirement	CFR Section	Report Section	Test Result
Antenna Requirement	15.203	4	Pass
AC Line Conducted Emissions	15.107, 15.207	5	Pass
Field Strength Limits (Fundamental and Harmonics)	15.249	6, 7	Pass
Transmitter Radiated Spurious Emissions	15.209, 15.249	6	Pass
Receiver Radiated Emissions	15.109	6	Pass

The client has made the determination that EUT Condition, Characterization, and Mode of Operation are representative of production units, and meet the requirements of the specifications referenced herein.

Consistent with Industry practice, measurement and test equipment not directly involved in obtaining measurement results but having an impact on measurements (such as cable loss, antenna factors, etc.) are factored into the "Correction Factor" documented in certain test results. Instrumentation employed for testing meets tolerances consistent with known Industry Standards and Regulations.

The measurements contained in this report were made in accordance with the procedure ANSI C63.4 - 1992 and all applicable Public Notices received prior to the date of testing. All emissions from the device were found to be within the limits outlined in this report.

The test results in this report apply only to the particular Equipment Under Test (EUT) as declared in this report.

Test Personnel: Wolfgang Döring
Issuance Date: 2002-12-13

4 ANTENNA REQUIREMENT

Test Requirement: FCC CFR47, Part 15C

4.1 Regulation

15.203 An intentional radiator shall be designed to ensure that no antenna other than that furnished by the responsible party shall be used with the device. The use of a permanently attached antenna or of an antenna that uses a unique coupling to the intentional radiator shall be considered sufficient to comply with the provisions of Part 15C. The manufacturer may design the unit so that the user can replace a broken antenna, but the use of a standard antenna jack or electrical connector is prohibited. This requirement does not apply to carrier current devices or to devices operated under the provisions of Sections 15.211, 15.213, 15.217, 15.219, or 15.221. Further, this requirement does not apply to intentional radiators that must be professionally installed, such as perimeter protection systems and some field disturbance sensors, or to other intentional radiators which, in accordance with Section 15.31(d), must be measured at the installation site. However, the installer shall be responsible for ensuring that the proper antenna is employed so that the limits in this Part are not exceeded.

According to DA 00-2225 "OET Extends Effective Date of Antenna Connector Requirement Indefinitely", dated September 28, 2000, the OET extends the effective date of Public Notice, DA 00-1087, indefinitely.

4.2 Result

Manufacturer: **IDENTEC SOLUTIONS AG**
Device: **i-CARD Interrogator**
Model No.: **i-Card3**
Serial Number: **none**

Antenna: external, quarter wavelength monopole: IDENTEC SOLUTIONS P/N 887124

The dedicated antenna is connected via MMCX connector. Based on DA 00-2225 MMCX connectors are still acceptable for satisfying the requirement in Section 15.203.

The EUT meets the requirements of this section.

5 CONDUCTED EMISSIONS TESTS

Test Requirement: FCC CFR47, Part 15C

Test Procedure: ANSI C63.4:1992

5.1 Regulation

Section 15.207 (a) Except as shown in paragraphs (b) and (c) of this section, for an intentional radiator that is designed to be connected to the public utility (AC) power line, the radio frequency voltage that is conducted back onto the AC power line on any frequency or frequencies within the band 150 kHz to 30 MHz shall not exceed the limits in the following table, as measured using a 50 μ H/50 ohms line impedance stabilization network (LISN). Compliance with the provisions of this paragraph shall be based on the measurement of the radio frequency voltage between each power line and ground at the power terminal. The lower limit applies at the boundary between the frequency ranges.

Frequency of Emission (MHz)	Conducted Limit (dBuV)	
	Quasi-peak (QP)	Average (AV)
0.15-0.5	66 to 56 *	56 to 46 *
0.5-5	56	46
5-30	60	50

* Decreases with the logarithm of the frequency.

Section 15.207 (c) Measurements to demonstrate compliance with the conducted limits are not required for devices which only employ battery power for operation and which do not operate from the AC power lines or contain provisions for operation while connected to the AC power lines. Devices that include, or make provision for, the use of battery chargers which permit operating while charging, AC adaptors or battery eliminators or that connect to the AC power lines indirectly, obtaining their power through another device which is connected to the AC power lines, shall be tested to demonstrate compliance with the conducted limits.

5.2 Test Equipment

Type	Manufacturer/ Model No.	Serial No.	Last Calibration	Next Calibration
EMI Receiver	Rohde & Schwarz ESS	825132/015	07/2002	07/2004
Protector Limiter 10 dB	Rohde & Schwarz ESH3-Z2 357.8810.52	844.165/032	n.a.	n.a.
V-LISN 50 ohms/(50 μ H + 5 ohms)	Schwarzbeck NSLK 8126	8126228	03/2002	03/2004
AC Mains Power Source 115 VAC 60 Hz	Elgar Model 501A with 400SR	1903 272	n.a.	n.a.

TEST OF IDENTEC SOLUTIONS AG I-CARD INTERROGATOR MODEL I-CARD3 TO 47 CFR PART 15.249

5.3 Test Procedures

For tabletop equipment, the EUT is placed on a 1 meter by 1.5 meters wide and 0.8 meter high nonconductive table that is placed above the groundplane. Ceiling or wall-mounted devices also is positioned on a tabletop for testing purposes. Floor standing equipment is placed either directly on the groundplane or on insulating material if normally placed on a nonconducting floor. The EUT is connected to its associated peripherals, with any excess I/O cabling bundled to approximately 1 meter. The EUT is connected to a dedicated LISN and all peripherals are connected to a second separate LISN circuit. The LISNs are bonded to the groundplane.

Conducted measurements are made on each current carrying conductor with respect to ground. Per ANSI C63.4-1992 clause 6.1.2.1 Remotely Located Devices. In certain applications, a remotely located device may be connected to the EUT. In these cases, it is permissible for cabling to the EUT or accessories to be placed directly upon the conducting ground plane or, if normally installed beneath the conducting ground plane, beneath it. The remotely located device shall be located at a distance sufficient to ensure that it does not contribute to the measured level.

Distributed networks, e.g. a local area network, may be simulated on the test site by a length of cable and an actual peripheral or a remote network communications simulator located at a distance sufficient to ensure that it does not contribute to the measured level.

The EUT was tested as a tabletop equipment installed in Compaq iPAQ Expansion Pack powered by the supplied AC adapter. Tests performed in RX/TX mode (normal tag reading process with data transfer to the handheld computer), in RX mode and additionally in TX test modes (CW and Cal. modulated). The initial step in collecting conducted data is a peak scan of the measurement range with an EMI test receiver. The significant peaks are then measured with quasi-peak detector. Worst case conducted emissions are listed under chapter: test results.

5.4 Test Results

Manufacturer: **IDENTEC SOLUTIONS AG**
 Device: **i-CARD Interrogator**
 Model No.: **i-Card3**
 Serial Number: **none**

PRODUCT EMISSIONS DATA RX/TX MODE										
No	Tested Line	Emission Frequency	Receiver Bandwidth	Quasi-peak (QP)			Average (AV)			Remarks
				Result	Spec Limit	Margin	Result	Spec Limit	Margin	
				[dBμV]	[dBμV]	[dB]	[dBμV]	[dBμV]	[dB]	
		[MHz]	[kHz]							
1	N	0.52	10	37.5	56	18.5	-	46	-	
2	N	0.6	10	37.8	56	18.2	-	46	-	
3	N	0.61	10	-	56	-	26.1	46	19.9	
4	L1	0.66	10	34.6	56	21.4	-	46	-	
5	N	1.06	10	35.6	56	20.4	-	46	-	
6	N	1.33	10	36	56	20	-	46	-	

TEST OF IDENTEC SOLUTIONS AG I-CARD INTERROGATOR MODEL I-CARD3 TO 47 CFR PART 15.249

PRODUCT EMISSIONS DATA RX MODE										
No	Tested Line	Emission Frequency [MHz]	Receiver Bandwidth [kHz]	Quasi-peak (QP)			Average (AV)			Remarks
				Result	Spec Limit	Margin	Result	Spec Limit	Margin	
				[dBμV]	[dBμV]	[dB]	[dBμV]	[dBμV]	[dB]	
1	L1	0.165	10	-	65.2	-	39.4	55.2	15.8	
2	N	0.33	10	-	59.5	-	35.6	49.5	13.9	
3	N	0.41	10	-	57.7	-	31	47.7	16.7	
4	N	0.575	10	40.3	56	15.7	31.9	46	14.1	
5	N	0.815	10	39.2	56	16.8	-	46	-	
6	N	0.91	10	40.5	56	15.5	-	46	-	

PRODUCT EMISSIONS DATA TX TEST MODE										
No	Tested Line	Emission Frequency [MHz]	Receiver Bandwidth [kHz]	Quasi-peak (QP)			Average (AV)			Remarks
				Result	Spec Limit	Margin	Result	Spec Limit	Margin	
				[dBμV]	[dBμV]	[dB]	[dBμV]	[dBμV]	[dB]	
1	N	0.285	10	-	60.7	-	34.3	50.7	16.4	MODULATED
2	N	0.495	10	-	56.1	-	31.9	46.1	14.2	MODULATED
3	N	0.495	10	39.4	56.1	16.7	30.5	46.1	15.6	CW
4	N	0.57	10	-	56	-	28.8	46	17.2	MODULATED
5	N	0.705	10	38.8	56	17.2	-	46	-	MODULATED
6	N	0.92	10	41	56	15	-	46	-	MODULATED
7	N	1.335	10	40.4	56	15.6	-	46	-	CW
8	N	1.35	10	40.2	56	15.8	-	46	-	MODULATED
9	N	1.99	10	40.3	56	15.7	-	46	-	MODULATED

The EUT meets the requirements of this section.

Test Personnel: Wolfgang Döring
 Test Date: 2002-10-28

6 RADIATED EMISSIONS

Test Requirement: FCC CFR47, Part 15C

Test Procedure: ANSI C63.4:1992

6.1 Regulation

Section 15.33 Frequency range of radiated measurements:

(a) Unless otherwise noted in the specific rule section under which the equipment operates for an intentional radiator the spectrum shall be investigated from the lowest radio frequency signal generated in the device, without going below 9 kHz, up to at least the frequency shown in this paragraph:

(1) If the intentional radiator operates below 10 GHz: to the tenth harmonic of the highest fundamental frequency or to 40 GHz, whichever is lower.

(4) If the intentional radiator contains a digital device, regardless of whether this digital device controls the functions of the intentional radiator or the digital device is used for additional control or function purposes other than to enable the operation of the intentional radiator, the frequency range shall be investigated up to the range specified in paragraphs (a)(1)-(a)(3) of this section or the range applicable to the digital device, as shown in paragraph (b)(1) of this Section, whichever is the higher frequency range of investigation.

(b) For unintentional radiators [*Remark: Applies to the receiver part / receive mode*]:

(1) Except as otherwise indicated in paragraphs (b)(2) or (b)(3), for an unintentional radiator, including a digital device, the spectrum shall be investigated from the lowest radio frequency signal generated or used in the device, without going below the lowest frequency for which a radiated emission limit is specified, up to the frequency shown in the following table:

Highest frequency generated or used in the device or on which the device operates or tunes (MHz)	Upper frequency of measurement (MHz)
Below 1.705	30
1.705 - 108	1000
108 - 500	2000
500 - 1000	5000
Above 1000	5th harmonic of the highest frequency or 40 GHz, whichever is lower

(3) Except for a CB receiver, a receiver employing superheterodyne techniques shall be investigated from 30 MHz up to at least the second harmonic of the highest local oscillator frequency generated in the device. If such receiver is controlled by a digital device, the frequency range shall be investigated up to the higher of the second harmonic of the highest local oscillator frequency generated in the device or the upper frequency of the measurement range specified for the digital device in paragraph (b)(1) of this Section.

Section 15.35 Measurement detector functions and bandwidths.

The conducted and radiated emission limits shown in this Part are based on the following, unless otherwise specified elsewhere in this Part:

(a) On any frequency or frequencies below or equal to 1000 MHz, the limits shown are based on measuring equipment employing a CISPR quasi-peak detector function and related measurement bandwidths, unless otherwise specified. The specifications for the measuring instrument using the CISPR quasi-peak detector can be found in Publication 16 of the International Special Committee on Radio Interference (CISPR) of the International Electrotechnical Commission. As an alternative to CISPR quasi-peak measurements, the responsible party, at its option, may demonstrate compliance

TEST OF IDENTEC SOLUTIONS AG I-CARD INTERROGATOR MODEL I-CARD3 TO 47 CFR PART 15.249

with the emission limits using measuring equipment employing a peak detector function, properly adjusted for such factors as pulse desensitization, as long as the same bandwidths as indicated for CISPR quasi-peak measurements are employed.

Note: For pulse modulated devices with a pulse-repetition frequency of 20 Hz or less and for which CISPR quasi-peak measurements are specified, compliance with the regulations shall be demonstrated using measuring equipment employing a peak detector function, properly adjusted for such factors as pulse desensitization, using the same measurement bandwidths that are indicated for CISPR quasi-peak measurements.

(b) On any frequency of frequencies above 1000 MHz, the radiated limits shown are based upon the use of measurement instrumentation employing an average detector function. When average radiated emission measurements are specified in the regulations, including emission measurements below 1000 MHz, there is also a limit on the radio frequency emissions, as measured using instrumentation with a peak detector function, corresponding to 20 dB above the maximum permitted average limit for the frequency being investigated unless a different peak emission limit is otherwise specified in the rules in this part, e.g., see § 15.255. Unless otherwise specified, measurements above 1000 MHz shall be performed using a minimum resolution bandwidth of 1 MHz. Measurement of AC power line conducted emissions are performed using a CISPR quasipeak detector, even for devices for which average radiated emission measurements are specified.

(c) Unless otherwise specified, e.g. Section 15.255(b), when the radiated emission limits are expressed in terms of the average value of the emission, and pulsed operation is employed, the measurement field strength shall be determined by averaging over one complete pulse train, including blanking intervals, as long as the pulse train does not exceed 0.1 seconds. As an alternative (provided the transmitter operates for longer than 0.1 seconds) or in cases where the pulse train exceeds 0.1 seconds, the measured field strength shall be determined from the average absolute voltage during a 0.1 second interval during which the field strength is at its maximum value. The exact method of calculating the average field strength shall be submitted with any application for certification or shall be retained in the measurement data file for equipment subject to notification or verification.

Section 15.209 (a) Except as provided elsewhere in this subpart, the emissions from an intentional radiator shall not exceed the field strength levels specified in the following table:

Frequency (MHz)	Field Strength (microvolts/meter)	Measurement distance (meters)
0.009–0.490	2400/F(kHz)	300
0.490–1.705	24000/F(kHz)	30
1.705–30.0	30	30
30–88	100	3
88–216	150	3
216–960	200	3
Above 960	500	3

(b) In the emission table above, the tighter limit applies at the band edges.

(c) The level of any unwanted emissions from an intentional radiator operating under these general provisions shall not exceed the level of the fundamental emission. For intentional radiators which operate under the provisions of other sections within this part and which are required to reduce their unwanted emissions to the limits specified in this table, the limits in this table are based on the frequency of the unwanted emission and not the fundamental frequency. However, the level of any unwanted emissions shall not exceed the level of the fundamental frequency.

(d) The emission limits shown in the above table are based on measurements employing a CISPR quasi peak detector except for the frequency bands 9–90 kHz, 110–490 kHz and above 1000 MHz. Radiated emission limits in these three bands are based on measurements employing an average detector.

TEST OF IDENTEC SOLUTIONS AG I-CARD INTERROGATOR MODEL I-CARD3 TO 47 CFR PART 15.249

- (e) The provisions in §§ 15.31, 15.33, and 15.35 for measuring emissions at distances other than the distances specified in the above table, determining the frequency range over which radiated emissions are to be measured, and limiting peak emissions apply to all devices operated under this part.
- (f) In accordance with Section 15.33(a), in some cases the emissions from an intentional radiator must be measured to beyond the tenth harmonic of the highest fundamental frequency designed to be emitted by the intentional radiator because of the incorporation of a digital device. If measurements above the tenth harmonic are so required, the radiated emissions above the tenth harmonic shall comply with the general radiated emission limits applicable to the incorporated digital device, as shown in Section 15.109 and as based on the frequency of the emission being measured, or, except for emissions contained in the restricted frequency bands shown in Section 15.205, the limit on spurious emissions specified for the intentional radiator, whichever is the higher limit. Emissions which must be measured above the tenth harmonic of the highest fundamental frequency designed to be emitted by the intentional radiator and which fall within the restricted bands shall comply with the general radiated emission limits in Section 15.109 that are applicable to the incorporated digital device.

Section 15.109 Radiated emission limits [*Remark: Applies to the receiver part / receive mode*].

(a) Except for Class A digital devices, the field strength of radiated emissions from unintentional radiators at a distance of 3 meters shall not exceed the following values:

Frequency (MHz)	Field Strength (microvolts/meter)
30–88	100
88–216	150
216–960	200
Above 960	500

Section 15.249 Operation within the bands 902 - 928 MHz, 2400 - 2483.5 MHz, 5725 - 5875 MHz, and 24.0 - 24.25 GHz.

(a) Except as provided in paragraph (b) of this section, the field strength of emissions from intentional radiators operated within these frequency bands shall comply with the following:

Fundamental Frequency (MHz)	Field Strength of Fundamental (millivolts/meter)	Field Strength of Harmonics (microvolts/meter)
902 - 928	50	500
2400 - 2483.5	50	500
5725 - 5875	50	500
24,000 – 24,250	250	2500

- (c) Field strength limits are specified at a distance of 3 meters.
- (d) Emissions radiated outside of the specified frequency bands, except for harmonics, shall be attenuated by at least 50 dB below the level of the fundamental or to the general radiated emission limits in Section 15.209, whichever is the lesser attenuation.
- (e) As shown in Section 15.35(b), for frequencies above 1000 MHz, the above field strength limits in paragraphs (a) and (b) of this section are based on average limits. However, the peak field strength of any emission shall not exceed the maximum permitted average limits specified above by more than 20 dB under any condition of modulation.

TEST OF IDENTEC SOLUTIONS AG I-CARD INTERROGATOR MODEL I-CARD3 TO 47 CFR PART 15.249

6.2 Test Equipment

Type	Manufacturer/ Model No.	Serial No.	Last Calibration	Next Calibration
Antenna (30 MHz - 1 GHz)	EMCO Model 3143	9604-1269	06/2002	12/2003
Receiver (30 MHz - 1 GHz)	Rohde & Schwarz ESS	825132/015	07/2002	07/2004
EMI Receiver / Analyzer (1 GHz – 10 GHz)	Rohde & Schwarz ESAI-D ESMI-RF ESMI-B1	833771/008 833827/002 832504/005	05/2002	11/2003
Antenna (1 GHz – 10 GHz)	Schwarzbeck BBHA 9120 D	248	09/2001	09/2003

6.3 Test Procedures

For tabletop equipment, the EUT is placed on a 1 meter by 1.5 meters wide and 0.8 meter high nonconductive table that is placed above the groundplane. Ceiling or wall-mounted devices also is positioned on a tabletop for testing purposes. Floor standing equipment is placed either directly on the groundplane or on insulating material if normally placed on a nonconducting floor. *[Remark: Not applicable]*. The EUT is connected to its associated peripherals, with any excess I/O cabling bundled to approximately 1 meter.

Per ANSI C63.4-1992 clause 6.1.2.1 Remotely Located Devices. In certain applications, a remotely located device may be connected to the EUT. In these cases, it is permissible for cabling to the EUT or accessories to be placed directly upon the conducting ground plane or, if normally installed beneath the conducting ground plane, beneath it. The remotely located device shall be located at a distance sufficient to ensure that it does not contribute to the measured level.

Distributed networks, e.g. a local area network, may be simulated on the test site by a length of cable and an actual peripheral or a remote network communications simulator located at a distance sufficient to ensure that it does not contribute to the measured level.

The EUT was tested on a 0.8 meter high tabletop. Tests performed in 2 configurations a) connected via the RS232 port to a remotely operated laptop PC and b) installed inside of a Compaq iPAQ Expansion Pack. Additionally radiated tests performed also with a PCMCIA-Card Extender. Measurement above 1 GHz performed placing the EUT at 1.5 meter high for better alignment with the antenna.

With the EUT operating in "worst case" mode, emissions from the unit are maximized by adjusting the polarization and height of the receive antenna and rotating the EUT on the turntable. Manipulating the system cables also maximizes EUT emissions *[Remark: Not applicable]*. All tests performed with the EUT placed in horizontal polarizations on the nonconductive table. Worst case emissions are listed under chapter: test results.

Radiated Emissions Test Characteristics	
Frequency range	30 MHz - 10,000 MHz
Test distance	3 m*
Test instrumentation resolution bandwidth	120 kHz (30 MHz - 1,000 MHz)
	1 MHz (1,000 MHz - 10,000 MHz)
Receive antenna scan height	1 m - 4 m
Receive antenna polarization	Vertical/Horizontal

TEST OF IDENTEC SOLUTIONS AG I-CARD INTERROGATOR MODEL I-CARD3 TO 47 CFR PART 15.249

* According to Section 15.31 (f)(1): At frequencies at or above 30 MHz, measurements may be performed at a distance other than what is specified provided: measurements are not made in the near field except where it can be shown that near field measurements are appropriate due to the characteristics of the device; and it can be demonstrated that the signal levels needed to be measured at the distance employed can be detected by the measurement equipment. (...) When performing measurements at a distance other than that specified, the results shall be extrapolated to the specified distance using an extrapolation factor of 20 dB/decade (inverse linear-distance for field strength measurements; inverse-linear-distance-squared for power density measurements).

6.4 Calculation of Field Strength Limits

E.g. radiated spurious emissions field strength limits for the restricted band 108-121.94 MHz:

$\mu\text{V/m}$ at 3 meters = 150

150 $\mu\text{V/m}$ corresponds with 43.5 dB $\mu\text{V/m}$.

6.5 Calculation of Average Correction Factor

The average correction factor is computed by analyzing the "worst case" on time in any 100 mSec time period and using the formula:

Corrections Factor (dB) = $20 \cdot \log(\text{worst case on time}/100 \text{ mSec})$

Section 15.249 Info: For the fundamental carrier in the 902-928 MHz, no duty cycle correction factor is permitted.

The relationship between average and peak mode reading has been confirmed by direct measurement using the receiver's average and peak detectors.

All emission measurements performed using the test receiver's average detector and the max. hold facility; i.e. the average value measured directly without the necessity of additional correction factor.

6.6 Field Strength Calculation

The field strength is calculated by adding the Antenna Factor and Cable Factor. The basic equation with a sample calculation is as follows:

$$\text{FS} = \text{RA} + \text{AF} + \text{CF}$$

where

FS = Field Strength in dB $\mu\text{V/m}$

RA = Receiver Amplitude in dB μV

AF = Antenna Factor in dB(1/m)

CF = Cable Attenuation Factor in dB

Assume a receiver reading of 23.5 dB μV is obtained. The Antenna Factor of 7.4 dB(1/m) and a Cable Factor of 1.1 dB are added, giving a field strength of 32 dB $\mu\text{V/m}$. The 32 dB $\mu\text{V/m}$ value can be mathematically converted to its corresponding level in $\mu\text{V/m}$.

$$\text{FS} = 23.5 + 7.4 + 1.1 = 32 \text{ [dB}\mu\text{V/m]}$$

Level in $\mu\text{V/m}$ = Common Antilogarithm (32/20) = 39.8

TEST OF IDENTEC SOLUTIONS AG I-CARD INTERROGATOR MODEL I-CARD3 TO 47 CFR PART 15.249

For test distance other than what is specified, but fulfilling the requirements of Section 15.31 (f)(1) the field strength is calculated by adding additionally an extrapolation factor of 20 dB/decade (inverse linear-distance for field strength measurements). The basic equation with a sample calculation is as follows:

$$FS = RA + AF + CF + DF$$

where

FS = Field Strength in dB μ V/m

RA = Receiver Amplitude in dB μ V

AF = Antenna Factor in dB(1/m)

CF = Cable Attenuation Factor in dB

DF = Distance Extrapolation Factor in dB,

where $DF = 20 \log (D_{test}/D_{spec})$ where D_{test} = Test Distance and D_{spec} = Specified Distance

Assume the tests performed at a reduced Test Distance of 1.5 m instead of the Specified Distance of 3 m giving a Distance Extrapolation Factor of $DF = 20 \log(1.5m/3m) = -6$ dB.

Assuming a receiver reading of 23.5 dB μ V is obtained. The Antenna Factor of 7.4 dB(1/m), the Cable Factor of 1.1 dB and the Distance Factor of -6 dB are added, giving a field strength of 26 dB μ V/m. The 26 dB μ V/m value can be mathematically converted to its corresponding level in μ V/m.

$$FS = 23.5 + 7.4 + 1.1 - 6 = 26 \text{ [dB}\mu\text{V/m]}$$

$$\text{Level in } \mu\text{V/m} = \text{Common Antilogarithm } (26/20) = 20$$

TEST OF IDENTEC SOLUTIONS AG I-CARD INTERROGATOR MODEL I-CARD3 TO 47 CFR PART 15.249

6.7 Test Results

Manufacturer: **IDENTEC SOLUTIONS AG**
 Device: **i-CARD Interrogator**
 Model No.: **i-Card3**
 Serial Number: **none**

PRODUCT EMISSIONS DATA, TRANSMIT MODE, FUNDAMENTAL AND HARMONICS											
No	Emission Frequency [MHz]	Receiver Bandwidth and Mode [kHz]	Test Distance [m]	Receiver Reading RA [dB(μV)]	Correction Factor AF+CF [dB(1/m)]	Distance Extrapol. Factor DF [dB]	Average Correction Factor [dB]	Result = Corrected Reading FS [dB(μV/m)]	Spec Limit [dB(μV/m)]	Polarization Ant.	Margin [dB]
1	916.5	120 QP	3	65.3	27.6	0	0	92.9	94.0	h	1.1
2	1833	1000, AV 1000, PK	1.5	AV 22.8 PK 31.5	25.3	-6	0	AV 42.1 PK 50.8	AV 54.0 PK 74.0	h	AV 11.9 PK 23.2
3	2749.5	1000, AV 1000, PK	1.5	AV 16 PK 23	28	-6	0	AV 38 PK 45	AV 54 PK 74	h	AV 16 PK 29
4	4582.5	1000, AV 1000, PK	1.5	AV 18.4 PK 25.6	30.6	-6	0	AV 43 PK 50.2	AV 54 PK 74	v	AV 11 PK 23.8
5				OTHER HARMONICS MORE THAN 20 dB BELOW CORRESPONDING LIMIT							
6											

PRODUCT EMISSIONS DATA, TRANSMIT MODE, (except fundamental and harmonics)													
No	Emission Frequency [MHz]	Receiver Bandwidth and Mode [kHz]	Test Distance [m]	Receiver Reading RA [dB(μV)]	Correction Factor AF+CF [dB(1/m)]	Distance Extrapol. Factor DF [dB]	Average Correction Factor [dB]	Result = Corrected Reading FS [dB(μV/m)]	Spec Limit * 15.209 / 15.249 [dB(μV/m)]	Polarization Ant.	Margin [dB]		
1	41.7	120, QP	3	23.5	10	0	0	33.5	40.0 / 42.9	v	9.4		
2	111.56	120, QP	3	26.2	8.3	0	0	34.5	43.5 / 42.9	v	9		
3	117.7	120, QP	3	23.4	8.5	0	0	31.9	43.5 / 42.9	v	11.6		
4	136.1	120, QP	3	19.3	10.7	0	0	30	43.5 / 42.9	v	13.5		
5	167	120, QP	3	19.2	10.8	0	0	30	43.5 / 42.9	h	13.5		
6	169.16	120, QP	3	21	10.7	0	0	31.7	43.5 / 42.9	h	11.8		
7	344.8	120, QP	3	23.5	17.5	0	0	41	46 / 42.9	h	5		
8				ALL EMISSIONS ABOVE 1 GHz MORE THAN 20 dB BELOW CORRESPONDING LIMIT									
9													
10													
11													

Remarks: * The less stringent limit (in **bold letters**) applies.

TEST OF IDENTEC SOLUTIONS AG I-CARD INTERROGATOR MODEL I-CARD3 TO 47 CFR PART 15.249

PRODUCT EMISSIONS DATA, RECEIVE MODE											
No	Emission Frequency	Receiver Bandwidth and Mode	Test Distance	Receiver Reading	Correction Factor	Distance Extrapol. Factor	Average Correction Factor	Result = Corrected Reading FS	Spec Limit	Polarization	Margin
	[MHz]	[kHz]	[m]	RA [dB(μV)]	AF+CF [dB(1/m)]	DF [dB]	[dB]	[dB(μV/m)]	15.209 [dB(μV/m)]	Ant.	[dB]
1	41.7	120, QP	3	23.5	10	0	0	33.5	40.0	v	6.5
2	111.56	120, QP	3	21.9	8.3	0	0	30.2	43.5	v	13.3
3	117.7	120, QP	3	20	8.5	0	0	28.5	43.5	v	15
4	189	120, QP	3	15	11.4	0	0	26.4	43.5	h	17.1
5	344.8	120, QP	3	14.7	17.5	0	0	32.2	46.0	h	13.8
6	1036	1200, PK	0.5	30.5	24.7	-15.6	0	39.6	54.0	v	14.4*

Remark: * Emissions caused by handheld PC (iPAQ).

For transmitter bandwidth plots and band-edge compliance plots refer to **Annex 4**.

The EUT meets the requirements of this section.

Test Personnel: Wolfgang Döring

Test Date: 2002-10-04, 2002-10-24, 2002-10-25, 2002-10-28

7 VARIATION OF OUTPUT POWER DUE TO INPUT VOLTAGE VARIATION

Test Requirement: FCC CFR47, Part 15C

7.1 Regulation

Section 15.31 (e) For intentional radiators, measurements of the variation of the input power or the radiated signal level of the fundamental frequency component of the emission, as appropriate, shall be performed with the supply voltage varied between 85% and 115% of the nominal rated supply voltage. For battery operated equipment, the equipment tests shall be performed using a new battery. The appropriate supply voltage variation for the 5 V supply (via USB port and RS232 respectively) is between 95% and 105% of the nominal rated supply voltage, i.e. between 4.75V and 5.25V.

7.2 Test Equipment

Type	Manufacturer/ Model No.	Serial No.	Last Calibration	Next Calibration
DC Supply	Rohde & Schwarz NGPE40	451292/0529	n.a.	n.a.
Voltmeter	ABB Metrawatt / M 2036	H27321747	07/2002	07/2003
Attenuator 20dB	Weinschel 4T-20	82339	11/2000	11/2002
EMI Receiver / Analyzer	Rohde & Schwarz ESAI-D ESMI-RF ESMI-B1	833771/008 833827/002 832504/005	05/2002	11/2003

7.3 Test Procedure

Use the following EMI Receiver/Analyzer settings:

EMI mode, Span = 1 MHz, centered on the fundamental transmit frequency, RBW = 120 kHz, Step = 50 kHz, Sweep = auto, Detector function = Quasipeak, Trace = max hold. Allow the trace to stabilize. Use the marker-to-peak function to set the marker to the peak of the emission. The indicated level is the quasipeak output power. Referring the obtained conducted power relations to the measured radiated emission under nominal conditions can be calculated the variation of the radiated fundamental emission.

Test performed with the EUT connected to the RS232 port of a laptop computer. For external supply the 5V supply of the RS232 cable was cut in the connector and an external adjustable DC supply connected.

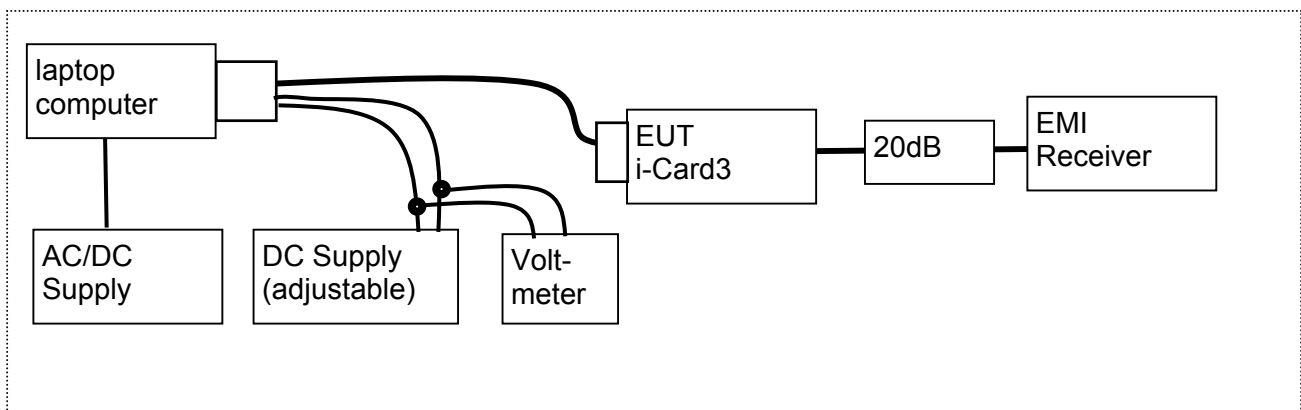

Figure: Test set-up

TEST OF IDENTEC SOLUTIONS AG I-CARD INTERROGATOR MODEL I-CARD3 TO 47 CFR PART 15.249

Test performed in normal operating mode (continuous tag reading process, 0.1 s delay).
All measurements performed successively at the nominal rated supply voltage, at 95% of the nominal voltage and at 105% of the nominal rated voltage (i.e. at the specified minimal and maximal input voltages).

7.4 Test Result

Manufacturer: **IDENTEC SOLUTIONS AG**
Device: **i-CARD Interrogator**
Model No.: **i-Card3**
Serial Number: **none**

PRODUCT FUNDAMENTAL EMISSIONS RX/TX MODE							
Input Voltage	Receiver QP Reading	Attenuator	Output Power	Power Variation	Fundamental Emissions	Spec. Limit QP	Margin
[V]	[dB(μV)]	[dB]	[dBm]	[dB]	[dBμV/m]	[dB(μV/m)]	[dB]
5.0	-28.5	20	-8.5	0	92.9	94	1.1
4.75	-27.8	20	-7.8	+0.7	93.6	94	0.4
5.25	-29.4	20	-9.4	-0.9	92.0	94	2

The EUT meets this requirement.

Test Personnel: Wolfgang Döring
Test Date: 2002-10-30

8 PRODUCT LABELING AND INFORMATION TO THE USER

8.1 Labeling

See **Annex 0** for label and label placement information.

8.2 Information to the User

Refer to **Annex 8** for the User Manual. This manual contains compliance information and is shipped with each product.

9 FURTHER PRODUCT INFORMATION

9.1 Theory of Operation

Proprietary document. Confidentiality requested for this document. Refer to **Annex 5**.

9.2 Block Diagram

Proprietary document. Confidentiality requested for this document. Refer to **Annex 6**.

9.3 Schematics, Parts Lists, Assembly Drawing

Proprietary documents. Confidentiality requested for these documents. Refer to **Annex 7**.

10 MISCELLANEOUS COMMENTS AND NOTES

None.

11 LIST OF ANNEXES

The following annexes are separated parts to this test report. These annexes may be file attachments for electronic filing.

Annex	Description	File name	Pages
Annex 0	Label and Label Placement Diagrams	010133BC_Annex0.pdf	2
Annex 1	Photographs of test setups	010133BC_Annex1.pdf	4
Annex 2	Photographs of equipment under test (EUT) external views	010133BC_Annex2.pdf	7
Annex 3	Photographs of equipment under test (EUT) internal views	010133BC_Annex3.pdf	5
Annex 4	Transmitter conducted measurement plots: Bandwidth and Band-edge Compliance	010133BC_Annex4.pdf	4
Annex 5	Theory of Operation	010133BC_Annex6.pdf	3
Annex 6	Block Diagram	010133BC_Annex7.pdf	2
Annex 7	Schematics, Parts List, Assembly Drawings	010133BC_Annex8.pdf	7
Annex 8	User Manual	010133BC_Annex9.pdf	11