

FCC Test Firm Designation Number: FR0014
SED Wireless Device Testing Laboratory CAB Number: FR0004

Matériel testé : Equipment under test:	IDENTEC SOLUTIONS / IDS1002 (i-Point X) <i>(Trademark / Marketing name or product reference)</i> NFC communication media (15.56MHz)
---	---

Client / Demandeur: **IDENTEC SOLUTIONS AG**
Customer / Applicant : Millennium Park 2
A-6890 Lustenau – Austria

Rapport délivré à : **IDENTEC SOLUTIONS AG**
Issued to: *Karl-Heinz Feierle*
Millennium Park 2
A-6890 Lustenau – Austria

Référence de la proposition : 012019-23396-1
Proposal number:

Numéro d'affaire : 12928
Work number :

Date de l'essai : Du 18 au 25 mai 2020
Date of test: *May 18th to 25th, 2020*

Objectif des essais : EMC qualification according to following standards:
Test purpose: - CFR 47, FCC Part 15, Subpart C
(Chapter 15.225 - Operation within the band 13.110-14.010 MHz)
- ISED Canada, RSS-Gen Issue 5 & RSS-210 Issue 10, section B.6
(Band 13.110-14.010 MHz)
Measurement standards:
ANSI C63.10 (2013)

Lieu du test: SMEE, Rue de Taille
Test location: 38500 VOIRON - France

Test réalisé par : Laurent CHAPUS
Test realized by:

Conclusion : L'équipement satisfait aux prescriptions et essais des normes citées en référence.
Conclusion: *The appliance complies with requirements and tests of above mentioned standards.*

Ed.	Date	Modifications Pages /	Written by : Visa	Approved by: Visa
1	September 7 th , 2020	Initial Edition	Laurent CHAPUS <i>Technical Manager</i>	Regis ANCEL <i>General Manager</i>

La copie de ce document n'est permise que sous sa forme intégrale. Ce document est le résultat d'essais effectués sur un échantillon. Il ne préjuge pas de la conformité de l'ensemble des produits fabriqués à l'objet essayé.
This document shall not be reproduced, except in full. This document contains results related only to the item tested. It does not imply the conformity of the whole production to the item tested.



Accréditation
N° 1-6356
Portée disponible sur :
Scope available on :
www.cofrac.fr

COORDONNEES

SMEE
Rue de Taille – ZI Des Blanchisseries
38500 VOIRON - France

TEL : 04 76 65 76 50
FAX : 04 76 66 18 30

SAS au capital de 50 000 € / RC Grenoble B534 796 453 / SIRET 534 796 453 00015 / code APE 7490B / n° TVA : FR 59 534 796 453

Contents

1. NORMATIVES REFERENCES	3
2. TEST SYNTHESIS.....	4
3. EQUIPMENT UNDER TEST (EUT).....	5
4. TEST CONDITIONS.....	5
5. MODIFICATIONS OF THE EUT.....	5
6. SPECIAL ACCESSORIES	5
7. MEASUREMENT UNCERTAINTY	6
8. FIELD STRENGTH CALCULATION.....	6
9. CONDUCTED EMISSION MEASUREMENT (150KHZ-30MHZ).....	7
10. FIELD STRENGTH OF FUNDAMENTAL.....	10
11. FUNDAMENTAL FREQUENCY TOLERANCE	12
12. UNWANTED EMISSIONS	14
13. 99% OCCUPIED BANDWIDTH	21

1. Normatives References

FCC qualification according to:		
Standards	Applied	Title
ANSI C63.10 (2013)	X	American National Standard for Testing Unlicensed Wireless Devices
CFR47, Part 15	X	Telecommunication – Federal Communication Commission – Radio frequency devices, Sections 15.207 / 15.209 / 15.225

ISED Canada qualification according to:		
Standards	Applied	Title
RSS-Gen (Issue 5/2019)	X	General Requirements and Information for the Certification of Radio Apparatus
RSS-210 (Issue10/2019)	X	Licence-exempt Radio Apparatus: Category I Equipment, Section B.6: Band 13.110-14.010MHz

Deviation from standards: None.

Other documents: 174176 D01 Line Conducted FAQ v01r01

2. Test synthesis

TEST	Paragraph number FCC Part 15 IC RSS-210	Spec. FCC Part 15 IC RSS-210	RESULTS (comments)
Conducted emissions test	15.207 (a) RSS-Gen: Issue 5, §8.8	15.207 (a) Table 4, §8.8	PASS
Field Strength of fundamental	15.225 (a) (b) (c) RSS-210: §B.6 (a)	<u>Measure at 30m</u> 13.110-13.410 MHz: 40.5dB μ V/m 13.410-13.553 MHz: 50.5dB μ V/m 13.553-13.567 MHz: 84.0dB μ V/m 13.567-13.710 MHz: 50.5dB μ V/m 13.710-14.010 MHz: 40.5dB μ V/m	PASS
Fundamental frequency tolerance	15.225 (e) RSS-210: §B.6 (b)	Shall be maintained to $\pm 0.01\%$ (± 100 ppm)	PASS
Unwanted emissions outside the specified frequency band	15.109 / 15.209 / 15.225 (d) RSS-210: §B.6 (a) / RSS-Gen: §8.9	<u>Measure at 300m</u> 9-490kHz: 2400 μ V/m/F(kHz) 6.370 μ A/m/F (kHz) <u>Measure at 30m</u> 0.490-1.705: 24000 μ V/m/F(kHz) 63.70 μ A/m/F (kHz) 1.705-30MHz: 30 μ V/m 0.08 μ A/m <u>Measure at 3m</u> 30MHz-88MHz : 40 dB μ V/m 88MHz-216MHz : 43.5 dB μ V/m 216MHz-960MHz : 46.0 dB μ V/m Above 960MHz : 54.0 dB μ V/m	PASS
Occupied Bandwidth	15.215 (c) RSS-Gen: Issue 5, §6.7	BW at 99%	PASS

- General conclusion:**

Measures and tests performed on the sample of the product **DENTEC SOLUTIONS / IDS1002**, in configuration and description presented in this test report, show compliance with standards FCC CFR 47, PART 15, Subpart C and ISED Canada RSS-Gen & RSS-210.

3. Equipment Under Test (EUT)

 Nom /
Identification

**IDENTEC SOLUTIONS / IDS1002
(i-Point X)**

(Trademark / Marketing name or product reference)

 P/N: 455990 (IDS1002)
Sn: 2019PR0172

 FCC ID: OO4-IDS1002
IC: IC : 3538A-IDS1002
Model: IDS1002

 Alimentation /
Power supply 15VDC from external power supply

 Auxiliaires /
Auxiliaries - Laptop ASUS, model F200M
- 15V DC power supply PHOENIX CONTACT UNO-PS/1AC/15DC/30W

 Entrées-Sorties /
Input / Output

	Câbles pour essai / Cables for test	Blindé / Shielded	Prévu pour >3m / Intended for >3m
RS422 (MASTER+15V)	2m/10m	YES	YES
RS422 (SLAVE)	2m	YES	YES

 Mode de fonctionnement /
Running mode

Equipment running modes are:

The tested sample is able to be set in following modes:

- Transmit a continuous modulated carrier frequency at 13.56MHz
- Transmit a continuous unmodulated carrier frequency at 13.56MHz

 Version programme interne /
Firmware version V101.01

 Programme de test /
Test program / PC test program "Gen3 Tag Certification tool" V.0.0.29105

 Informations supplémentaires /
Additional informations

Declaration of the applicant:

- Type of technology: NFC (ISO/IEC 15693, ISO/IEC 14443A&B, Sony FeliCa)
- Emission bands: 13.110-14.010 MHz
- Equipment intended for use as a fixed station
- Equipment designed for continuous operation
- Antenna type: Integrated 13.56MHz coil (read/write)

 Dimensions de l'EST /
Dimensions of EUT 224mm x 214 x 46

4. Test conditions

 Power supply voltage: 15V DC
Equipment under test: 230V/50Hz (Radiated emission)
Auxiliaries (AC mains): 110V/60Hz (Conducted emission)

5. Modifications of the EUT

None.

6. Special accessories

None required for compliance with emission limits.

7. Measurement Uncertainty

Test Description	Expanded uncertainty
Conducted emissions test (150k-30MHz, AC mains)	± 3.5dB
Radiated emission test (9kHz-30MHz, electric field)	± 4.0dB
Radiated emission test (30-300MHz, OATS)	± 5.6dB
Radiated emission test (300-1000MHz, OATS)	± 5.3dB
Radiated emission test (1-40GHz, OATS / FAC)	± 5.6dB
Conducted RF output power at antenna port	± 1.6dB
Radiated RF output power (Peak, Power density)	± 5.6dB
DTS Bandwidth, 99% OBW	±4%
Temperature	± 1°C
Time and duty cycle calculation	±1%
AC and DC voltage	±1%

Note: Expanded uncertainty at 95% confidence (k=2)

8. Field Strength Calculation

The field strength (level) is calculated by adding the Antenna Factor and Cable Factor, and subtracting the Amplifier Gain (if any) from the measured reading. The basic equation is as follow:

$$FS = RA + AF + CF - AG$$

Where FS = Field Strength (Level)

RA = Receiver Amplitude (Meter Reading)

AF = Antenna Factor

CF = Cable Factor

AG = Amplifier Gain

Total factor = AF+CF-AG

Margin value = Emission level – Limit value

Example:

RA: 14.0dBμV / AF: 16.5 dBm⁻¹ / CF: 3.5dB / AG: 15dB

→ Total factor: 5dBm⁻¹

→ Field level: 19.0dBμV/m (-21.0dB for margin if limit is 40dBμV/m)

9. Conducted Emission Measurement (150kHz-30MHz)

TEST: Limits for conducted disturbance 150kHz – 30MHz				Verdict	
<p><u>Method:</u> The LISN is placed 0,8 m from the boundary of the unit under test and bonded to a ground reference plane. This distance was between the closest points of the AMN and the EUT. All other units of the EUT and associated equipment were at least 0,8 m from the AMN. All power was connected to the system through Artificial Mains Network (AMN). Conducted voltage measurements on lines were made at the output of the LISN. The EUT is 80cm above the ground reference plane and 40cm from the vertical ground plane. The AC power cable is 1m length.</p>				Pass	
Laboratory Parameters:		Required prior to the test		During the test	
Ambient Temperature		20 to 30 °C		25°C ± 2	
Relative Humidity		25 to 70 %		45% ± 5	
Fully configured sample scanned over the following frequency range		Frequency range on each side of line		Measurement Point	
		150kHz to 30MHz		AC input port (110V)	
Limits					
Frequency (MHz)	Limit dB (µV)				
	Quasi-Peak	Result	Average	Result	
0.15 – 0.50	66 \ 56	PASS	56 \ 46	PASS	
0.50 - 5	56	PASS	46	PASS	
5 – 30	60	PASS	50	PASS	
Supplementary information:					
Test location: SMEE					
Test date: May 20 th , 2020. Tested by L. CHAPUS					
Power supply voltage: 15V/DC from external power supply (AC mains 110V/60Hz)					

Test Equipment Used					
Description	Manufacturer	Model	Identifier	Cal. Date	Cal. Due
AC power supply	PACIFIC POWER	AMX-125	ALI-101-002	-	-
Attenuator / limiter	SMEE	ATT#2	ATT-171-010	2019/6	2020/6
Cable RF	Div	1m	CAB-101-021	2020/4	2020/4
Measuring receiver	Rohde&Schwarz	ESRP	REC-151-002	2019/9	2021/9
LISN (50Ω / 50µH) (Meas.)	AFJ	LS16C	RSI-101-001	2019/6	2021/6
EMC Software	NEXIO	BAT EMC V3.18	SOF-101-001	-	-

Test Setup for conducted emission

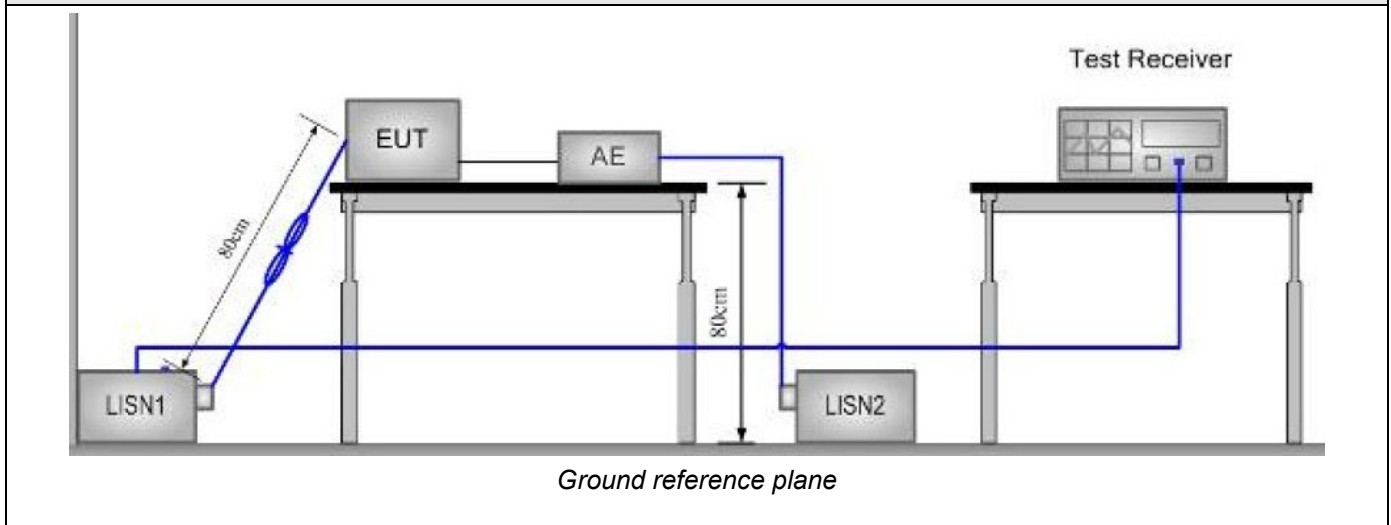

Tabulated Results for Mains Terminal Disturbance Voltage on AC port

FREQ (MHz)	Meas. PK (dB μ V)	Mes. QP (dB μ V)	LIMIT QP (dB μ V)	Margin QP (dB)	Mes. AV (dB μ V)	LIMIT AV (dB μ V)	Margin AV (dB)	Line
13.56	65.83	65.24	60	5.24	61.23	50	11.23	L1 (1)
13.56	48.24	47.89	60	-12.11	45.29	50	-4.71	L1 (2)
13.56	67.06	66.39	60	6.39	62.49	50	12.49	N (1)
13.56	49.56	48.11	60	-11.89	47.52	50	-2.48	N (2)
Frequency band investigated:			150kHz-30MHz					
RBW:			9kHz					
Voltage:			110V/60Hz					
Limit:			15.207 / RSS-GEN §8.8					
Final measurement detector:			Quasi-Peak and CISPR Average (AV)					
RESULT:			PASS					
Notes:			(1): Transmitter's fundamental emission band (2) : Retest with a dummy load in lieu of the antenna					
Measured value calculation:			<p>The measured value (level) is calculated by adding the Cable Factor, the Transient suppressor attenuation and LISN attenuation from the receiver amplitude reading. The basic equation is as follow:</p> $\text{Meas.} = \text{RA} + \text{CF} + \text{ATT}_{\text{TRAN}} + \text{ATT}_{\text{LISN}}$ <p>Where Meas. = Level (dBμV) RA = Receiver Amplitude CF = Cable Factor ATT_{TRAN} = Transient suppressor attenuation ATT_{LISN} = LISN attenuation</p> <p>Margin value = Emission level – Limit value (A negative margin shows compliance to limit)</p>					

Graphical representation of Conducted Disturbance Measurement (Peak and Average detection) AC port, Line L1

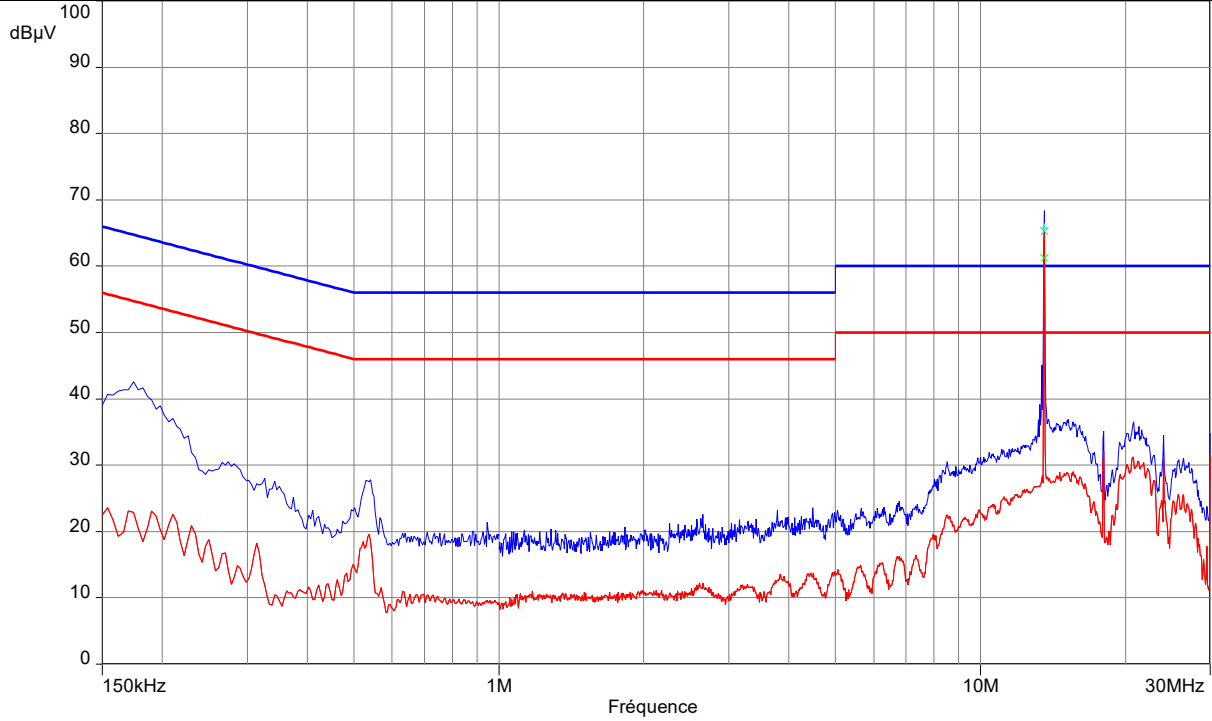

----: Peak

----: Average

Graphical representation of Conducted Disturbance Measurement (Peak and Average detection) AC port, Line Neutral

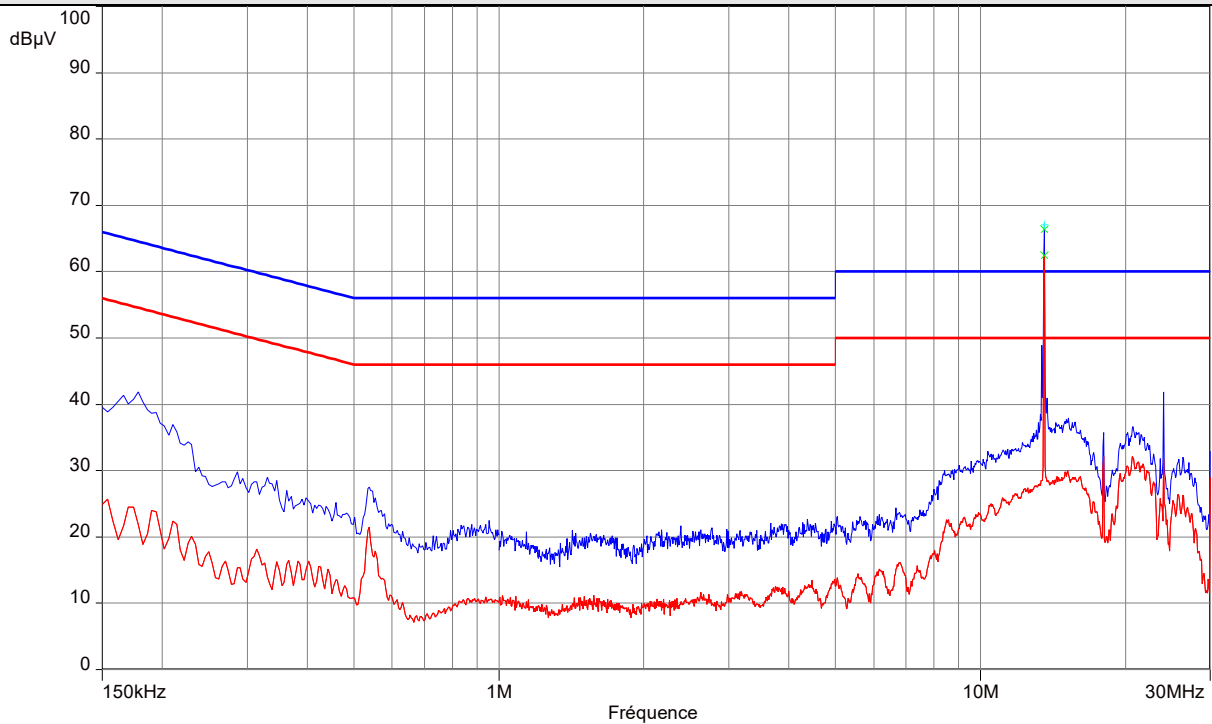

----: Peak

----: Average

10. Field Strength of fundamental

TEST: Field strength of fundamental / FCC part 15.225 – RSS 210 §B.6		Verdict
<p>Method: Measurements were made in a 10-meter Open Area Test Site (OATS) that complies to ANSI C63.4/C63.10 and RSS-Gen. Measurements were performed with peak detector using a 9kHz RBW. The EUT was rotated 360° about its azimuth with the receive antenna located at 1-meter in horizontal and vertical polarities. Final measurements (Quasi-Peak) were then performed by rotating the EUT 360°. The tested equipment is set to transmit operation with modulation. Three orthogonal axis measurements on EUT are performed to obtain the maximum peak field strength.</p>		Pass
Laboratory Parameters:	Required prior to the test	During the test
Ambient Temperature	10 to 40 °C	25°C ± 2
Relative Humidity	10 to 90 %	45% ± 5
Limits – FCC Part 15.225 (a) (b) (c) / RSS-210 §B.6 (a) (b) (c) Operation within the band 13.110-14.010 MHz		
Frequency (MHz)	Limits (dBµV/m)	
	Level / Distance	Results
13.553-13.567 MHz	84.0dBµV/m / 30m	Pass
13.410-13.553 / 13.567-13.710	50.5dBµV/m / 30m	Pass
13.110-13.410 / 13.710-14.010	40.5dBµV/m / 30m	Pass
Outside 13.110 to 14.010 MHz	29.5dBµV/m / 30m	See chapter 9.
Supplementary information: Test location: SMEE Test date: May 18 th , 2020. Tested by L. Chapus		

Test Equipment Used					
Description	Manufacturer	Model	Identifier	Cal. Date	Cal. Due
Measuring Rec.	Rohde&Schwarz	ESRP	REC-151-002	2019/9	2021/9
Loop antenna	EMCO	6502	ANT-101-009	2019/8	2021/8
RF cable	Div	OATS/25m	CAB-101-017	2020/4	2021/4
OATS	Div	3 / 10m	SIT-101-001	2017/7	2020/7
Antenna mast	Innco- Systems	MA4000EP	MAT-101-001	-	-
Turntable	Innco- Systems	DS1200S	PLA-101-001	-	-

Tabulated Results for Field Strength of fundamental

FREQ	RF field @ 30m	Limit @ 30m	Margin	Antenna angle	Table angle	Correc. Fact. (CF)
MHz	dB μ V/m	dB μ V/m	dB	Degree	Degree	dB
13.56	36.7	84.0	-49.5	H / 110°	90	10.8
RBW:		9kHz (150kHz-30MHz)				
Measurement distance:		10m				
Limit:		FCC Part 15.225 (a) (b) (c) / RSS-210 §B.6				
Final measurement detector:		Quasi-Peak				
RESULT:		PASS				
Note:		CF: Correction factor = Antenna factor + Cable loss Measure have been done at 10m distance and corrected according to requirements of 15.209.e) (M@30m = M@10m-19.1dB)				

Graphical representation of Radiated E-field Band Edge compliance within the band 13.110-14010 MHz

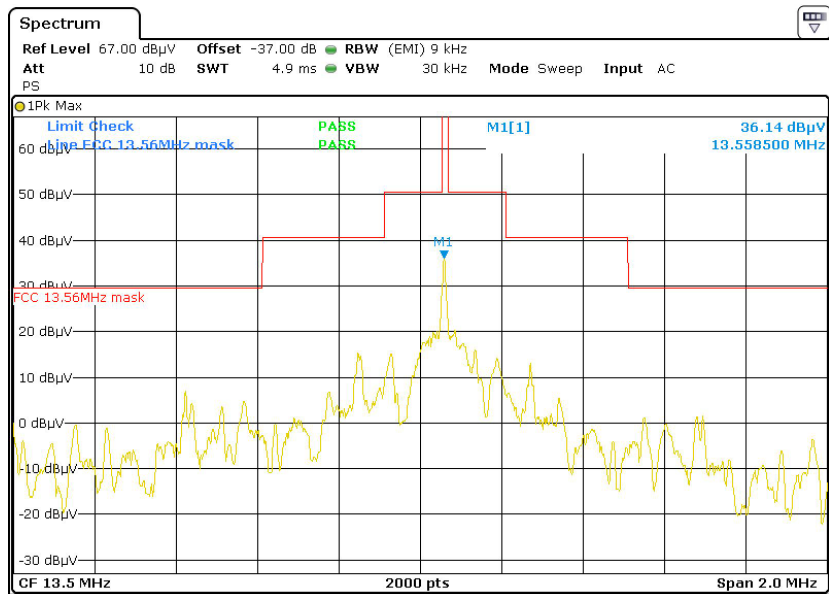

Frequency band investigated:	12.5MHz to 14.5MHz
Unit :	dB μ V/m
RBW :	9kHz
Voltage:	15V DC
Limit:	FCC Part 15.225 (a) (b) (c) (d)
Measurement detector:	Peak

11. Fundamental frequency tolerance

TEST: Fundamental frequency tolerance / FCC part 15.225 – RSS-210 §B.6		Verdict
Method: The frequency tolerance of the carrier signal shall be maintained within $\pm 0.01\%$ of the operating frequency when the temperature is varied from -20°C to $+50^{\circ}\text{C}$ at the nominal power voltage and the primary power voltage is varied from 85% to 115% of the rated supply voltage at 20°C . The equipment is placed in a climatic chamber. Carrier level and frequency are measured using a test fixture.		Pass
Laboratory Parameters:	Required prior to the test	During the test
Ambient Temperature	10 to 40°C	$25^{\circ}\text{C} \pm 2$
Relative Humidity	10 to 90 %	$45\% \pm 5$
Fully configured sample scanned over the following frequency range		
Carrier Signal :	13.56MHz	
Normal test temperature :	20°C	
Normal power voltage :	15V DC	
Extreme Temperature variation :	-20°C to $+50^{\circ}\text{C}$	
Extreme Voltage variation :	$15\text{V} \pm 15\%$	
Limits – FCC Part 15.225 (e) / RSS-210 §B.6 (e)		
Frequency (MHz)	Limits	Results
13.56MHz	$\pm 0.01\%$ or 100ppm Min. and Max. frequency shall be within 13.553 to 13.567 MHz	Pass
Supplementary information: Test location: SMEE Test date: May 25 th , 2020. Tested by L. Chapus		

Test Equipment Used					
Description	Manufacturer	Model	Identifier	Cal. Date	Cal. Due
Shielded loop antenna	SMEE	5cm	ANT-171-018	-	-
RF cable	Pasternack	PE302-120	CAB-131-024	2019/4	2020/6
Climatic chamber	VÖTSCH	VT 3050	CLI-101-001	2018/12	2020/12
Measuring Rec	Rohde&Schwarz	ESRP	REC-151-002	2019/9	2021/9
DC power supply	AGILENT	6654A	ALI-101-003	-	-
Multimeter	FLUKE	287	MUL-131-005	2019/11	2021/11
DATA LOGGER (Temperature)	AGILENT	34970A	DLG-101-001	2019/11	2021/11
DATA LOGGER (Mux board)	AGILENT	34901A	DLG-101-002	2019/11	2021/11

Test Setup for frequency stability

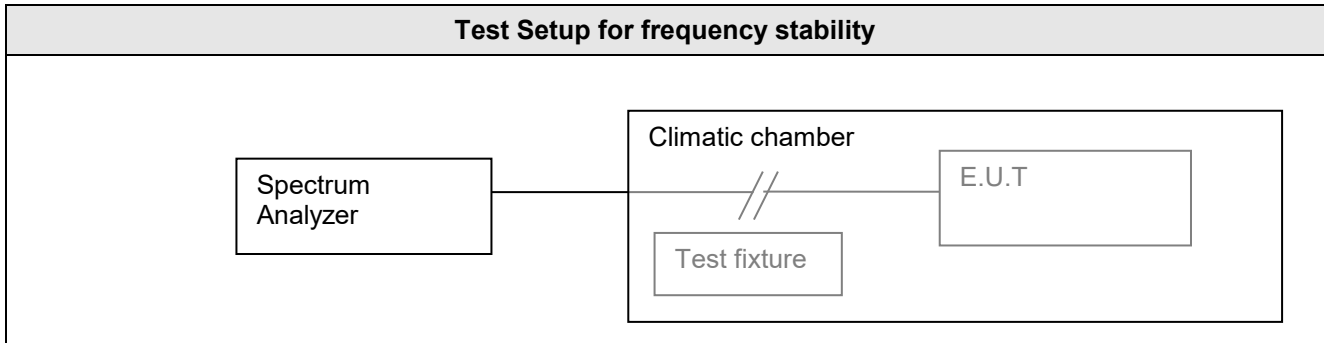

Tabulated Results for fundamental frequency stability

Temperature (°C)	VOLTAGE (V DC)	Frequency after 0s (Startup) (Hz)	Frequency after 2min (Hz)	Frequency after 5min (Hz)	Frequency after 10min (Hz)
50	15	13558869	13558865	13558855	13558850
40	15	13558875	13558870	13558866	13558855
30	15	13558901	13558894	13558890	13558880
20	15	13558935	13558926	13558918	13558911
20	12.75	13558935	13558926	13558918	13558911
20	17.25	13558935	13558926	13558918	13558911
10	15	13558950	13558947	13558945	13558945
0	15	13558930	13558925	13558911	13558908
-10	15	13558990	13558985	13558981	13558980
-20	15	13559031	13559030	13559030	13559025
Ref Value		13558935	Hz		
MIN Frequency		13558850	Hz		
Limit MIN Frequency		> 13.553	MHz		
MAX frequency		13559031	Hz		
Limit MAX Frequency		< 13.567	MHz		
Overall stability		181	Hz		
Limit for stability		1355.9	Hz		
Result		PASS			

12. Unwanted emissions

TEST: Unwanted emissions outside the specified frequency band / FCC part 15.209, 15.225 - RSS-210 §B.6		Verdict
<p>Method: Measurements were made in a 3-meter Open Area Test Site that complies to ANSI C63.4/ C63.10 for frequency below 1GHz. Measurements were made in a 3-meter Full Anechoic Chamber (FAC) that complies to ANSI C63.10 for frequency above 1GHz.</p> <p>The EUT was rotated 360° about its azimuth with the receive antenna located at various heights in horizontal and vertical polarities. Final measurements (Peak/Quasi-Peak/Average) were then performed by rotating the EUT 360° and adjusting the receive antenna height.</p> <p>The tested equipment is set to transmit operation with modulations on lowest, middle and highest channel. Three orthogonal axis measurements on EUT are performed to obtain the maximum peak field strength. A pre-scan frequency identification of the EUT has been performed in full anechoic chamber. The measured radiated field of the EUT is performed at 3-meters of distance for frequency 9k-1GHz. The measured radiated field of the EUT is performed at 1.6-meters of distance for frequency 1-25GHz. Antenna is 1.25m (Freq < 1GHz) or 1.5m (Freq < 1GHz) high in front of EUT.</p>		Pass
Laboratory Parameters:	Required prior to the test	During the test
Ambient Temperature	20 to 30 °C	25°C ± 2
Relative Humidity	30 to 70 %	45% ± 5
Fully configured sample scanned over the following frequency range	Frequency range on each side of line	Measurement Point
	9kHz – 30MHz	10 m measurement distance
	30MHz – 10GHz	3 m measurement distance
Limits – FCC Part 15.209, 15.225 (d) / RSS-210 §B.6		
Frequency (MHz)	Limits (dBµV/m)	
	Level / Detector / Distance	Results
0.009 to 0.090	107.6 – 87.6 / AV / 10m 127.6 – 107.6 / PK / 10m	Pass
0.090 to 0.110	87.6 – 85.9 / QP / 10m	Pass
0.110 to 0.490	85.7 – 72.9 / AV / 10m 105.7 – 92.9 / PK / 10m	Pass
0.490 to 1.705	52.9 – 42.1 / QP / 10m	Pass
1.705 to 30	48.6 / QP / 10m	Pass
30 to 88	40.0 / QP / 3m	Pass
88 to 216	43.5 / QP / 3m	Pass
216 to 960	46.0 / QP / 3m	Pass
960-1000	54.0 / QP / 3m	Pass
Above 1GHz	54.0 / AV / 3m 74.0 / PK / 3m	Pass
Supplementary information: Test location: SMEE Test date: May 18 th , 2020. Tested by L. Chapus		

Test Equipment Used					
Description	Manufacturer	Model	Identifier	Cal. Date	Cal. Due
Log-periodic antenna	EMCO	3146	ANT-191-019	2019/6	2021/6
Biconnic antenna	COM-POWER	AB- 900	ANT-101-003	2019/6	2021/6
Loop antenna	EMCO	6502	ANT-101-009	2019/8	2021/8
BiConiLog antenna	EMCO	3142B	ANT-101-010	2019/8	2021/8
Horn antenna	ETS-LINDGREN	3115	ANT-141-013	2018/10	2021/10
Spectrum analyzer	Rohde&Schwarz	FSV40	ASP-171-004	2019/8	2021/8
RF cable	Div	OATS/25m	CAB-101-017	2020/4	2021/4
RF cable	Pasternack RF	PE302-120	CAB-131-024	2019/4	2020/6
RF cable	HUBER+SUHNER	RG214U	CAB-141-026	2019/4	2020/6
RF cable	HUBER+SUHNER	RG214U	CAB-141-029	2019/4	2020/6
RF cable	HUBER+SUHNER	SF104	CAB-141-030	2019/4	2020/6
Pre-amplifier	Pasternack RF	PE1524	PRE-101-002	2019/6	2020/6
Anechoic chamber	COMTEST	214263	CAG-141-001	2017/6	2020/6
OATS	Div	10m	SIT-101-001	2017/7	2020/7
Antenna mast	Innco- Systems	MA4000EP	MAT-101-001	-	-
Turntable	Innco- Systems	DS1200S	PLA-101-001	-	-
Turntable	Innco- Systems	CT0800	PLA-141-001	-	-
Measuring Rec	Rohde&Schwarz	ESRP	REC-151-002	2019/9	2021/9
EMC Software	NEXIO	BAT EMC V3.18	SOF-101-001	-	-

Test Setup for radiated emission

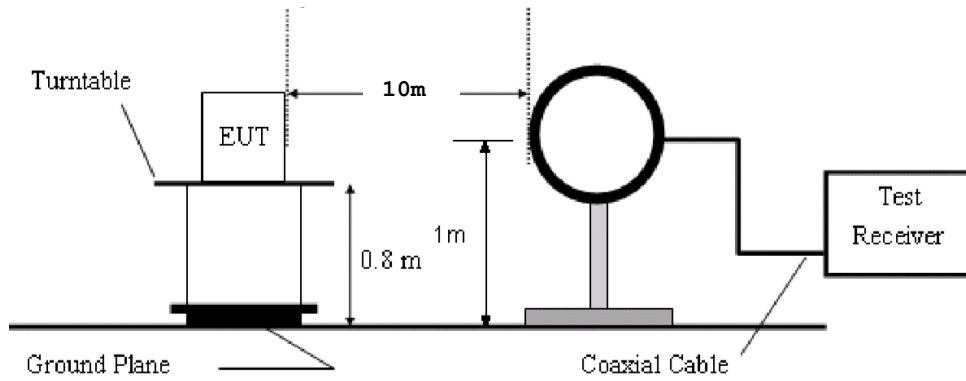

Test setup for 9k-30MHz

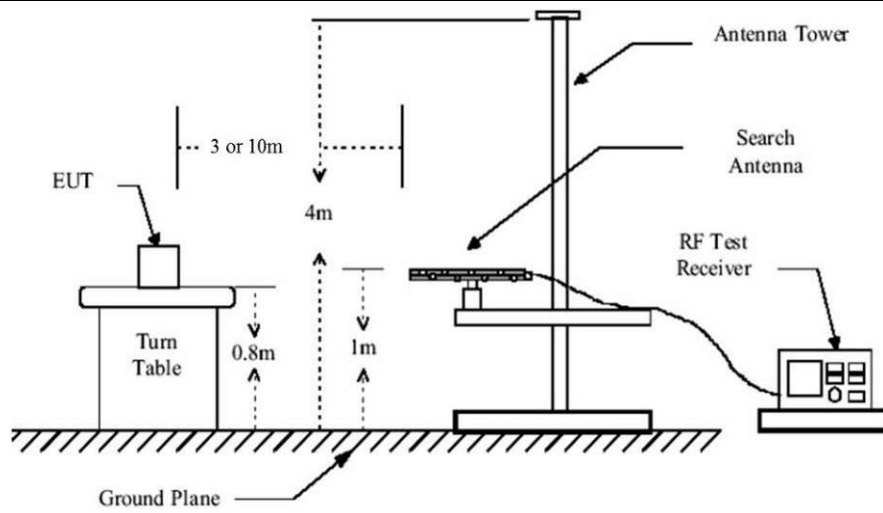

Test setup for 30-1000MHz (3m)

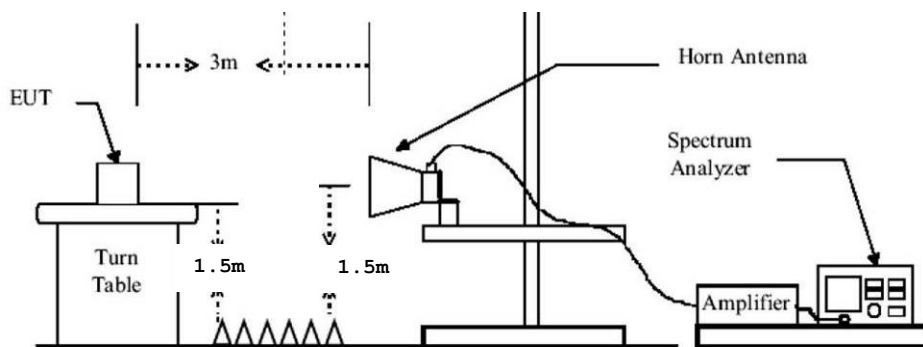

Test setup for 1-10GHz

Tabulated Results for Unwanted emissions (9kHz-30MHz)							
FREQ	RF field @ 30m	Limit @ 30m	Margin	Antenna		Table angle	Correc. Fact. (CF)
MHz	(QP) dBµV/m	(QP) dBµV/m	dB	Angle (Degree)	Position	Degree	dB
Levels are at least 10dB below limits							
Supplementary information: Frequency list measured on the Open Area Test Site has been created with pre-scan results.							
Frequency band investigated:		9kHz-30MHz					
RBW:		200Hz (9kHz-150kHz) 9kHz (150kHz-30MHz)					
Measurement distance:		10m					
Limit:		FCC Part 15.209 / RSS-Gen §8.9 – RSS-210 §B.10					
Final measurement detector:		Peak / Quasi-Peak / Average					
Note:		CF: Correction factor = Antenna factor + Cable loss *1: Measure have been done at 10m distance and corrected according to requirements of 15.209.e / RSS-Gen clause 6.5) M@300m = M@10m-59.1dB / M@30m = M@10m-19.1dB					

Tabulated Results for Radiated Disturbance (3m measurement on Open Area Test Site, 30MHz-1GHz)										
FREQ	Meter reading	Meter reading	Total Factor	Field level	Field level	Pol	Antenna height	Table angle	Limit	Margin
MHz	(QP) dBµV	(Pk) dBµV	dB	(QP) dBµV/m	(Pk) dBµV/m		cm	Degré	(QP) dBµV/m	dB
Levels are at least 10dB below limits										
Supplementary information: Frequency list measured on the Open Area Test Site is created with pre-scan results.										
Frequency band investigated:		30MHz-1GHz								
RBW:		120kHz								
Measurement distance:		3m								
Limit:		FCC Part 15.209 / RSS-Gen §8.9 – RSS-210 §B.10								
Final measurement detector:		Quasi-Peak								
RESULT:		PASS								

Tabulated Results for Unwanted emissions (1GHz-10GHz)				
FREQ	Field level	Detector	Limit	Result
(MHz)	dBµV/m		(dBµV/m)	
Levels at least 10dB below limits		Pk	74 Pk	Pass
Levels at least 10dB below limits		Av	54 Av	Pass
RBW	1MHz (CISPR)			
Measurement distance:	3m			
Limit:	FCC Part 15.209 / RSS-Gen §8.9 – RSS-210 §B.10			
Final measurement detector:	Peak / CISPR Average			
RESULT:	PASS			

Graphical representation of Radiated Disturbance Measurement (Peak detection, Anechoic chamber pre-scan, 9kHz-30MHz / 3m / Parallel & Perpendicular antenna position / Transmit mode)

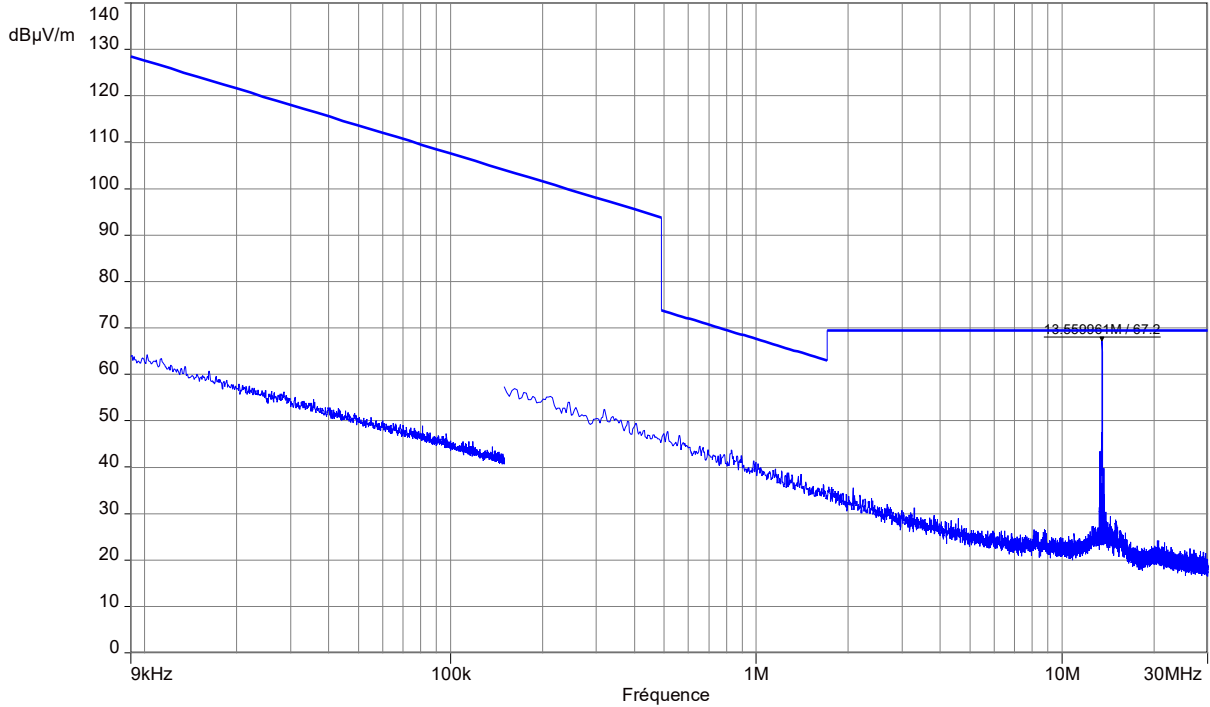

Notes: Pre-scan graph only for identification purpose.

Frequency band investigated:	9kHz-30MHz
Unit :	dBµV/m
RBW :	200Hz (9kHz-150kHz) 9kHz (150kHz-30MHz)
Antenna polarization :	Parallel & Perpendicular to measurement axis (Worst case shown)
Measurement detector:	Peak

Graphical representation of Radiated Disturbance Measurement (Anechoic chamber pre-scan, 30MHz-1GHz / 3m)

Horizontal polarization

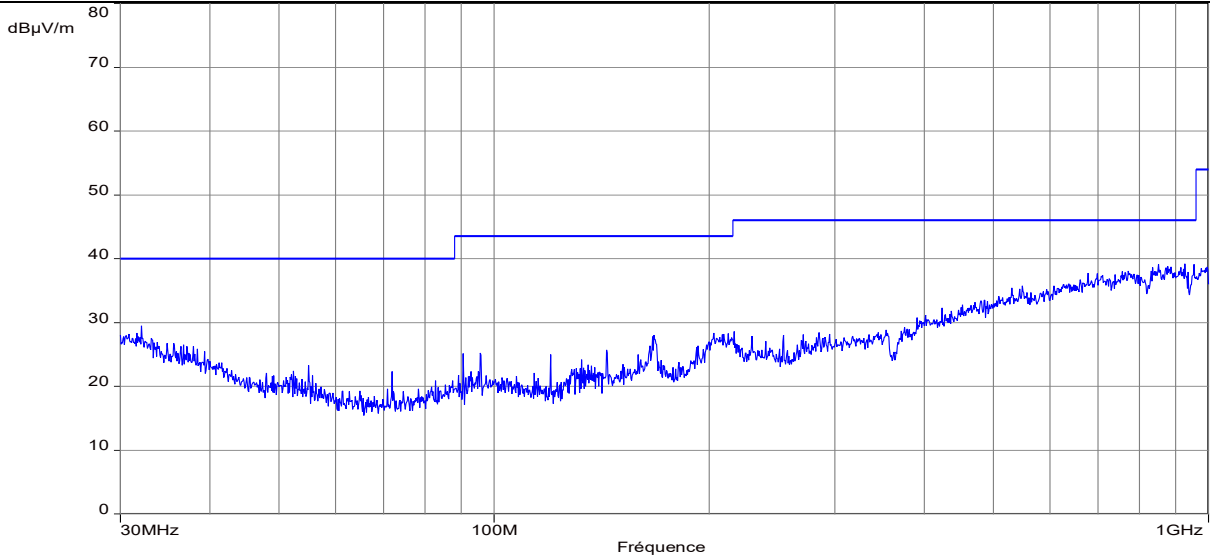

Vertical polarization

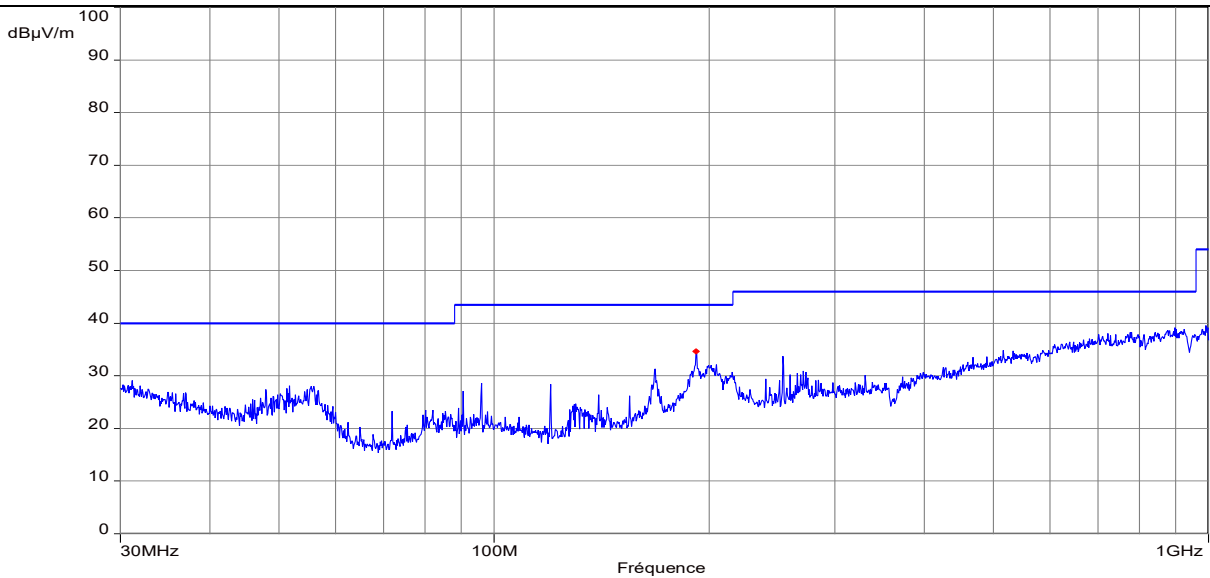

----- : Peak measure / limits

Note: Pre-scan graph only for identification purpose.

Marker List :

Frequency (MHz)	Peak Level (dBµV/m)	Limit (dBµV/m)	Polarization
191.965	34.67	43.5	V

Graphical representation of Radiated Disturbance Measurement (Peak detection, Anechoic chamber pre-scan, 1GHz-10GHz / 3m)

Horizontal polarization

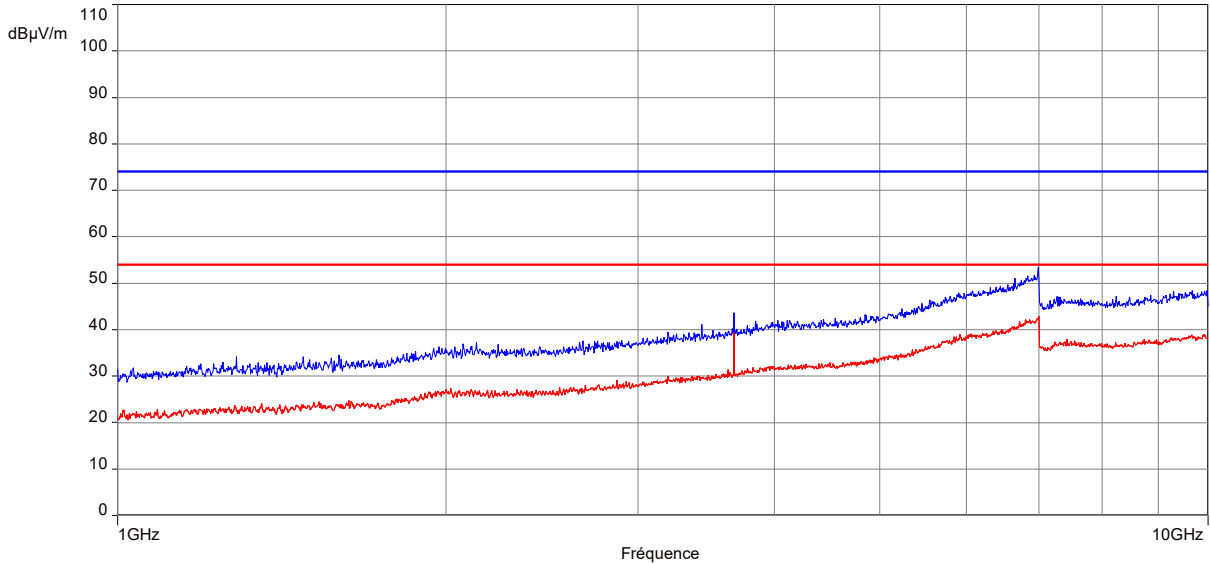

Vertical polarization

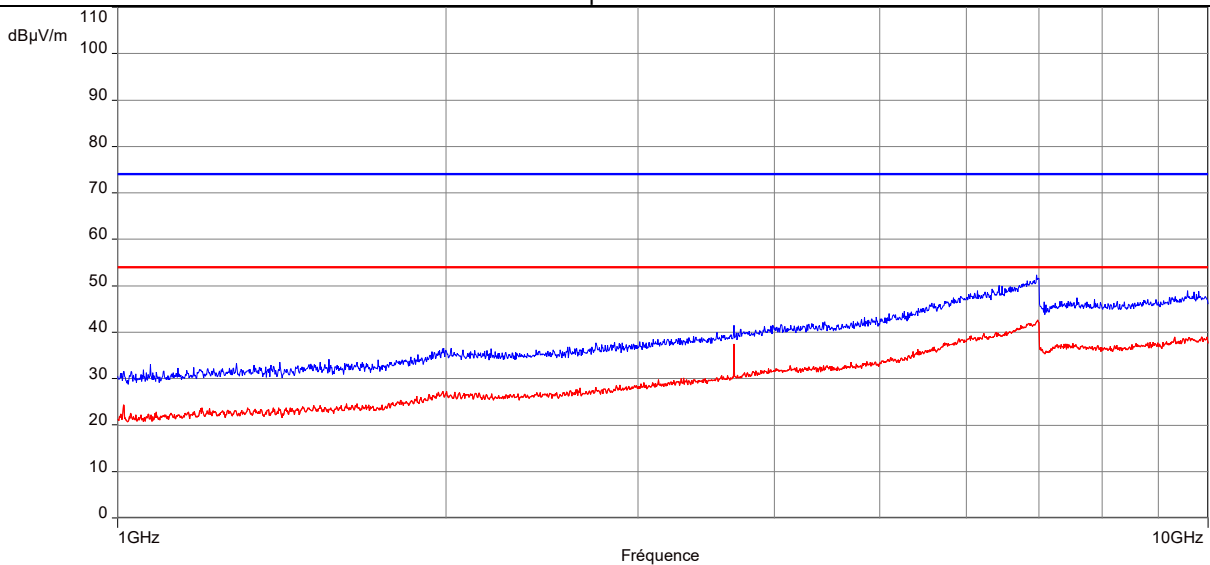

----- : Peak measure / limit - - - - - : AVG measure / limit

Note: Pre-scan graph only for identification purpose.

Marker List :

Frequency (MHz)	Peak Level (dBµV/m)	Limit (dBµV/m)	Polarization
None	-	-	-

13. 99% Occupied Bandwidth

TEST: Occupied bandwidth (99%) / RSS-GEN		Verdict
<p>Method: The setup is in an anechoic chamber. The spectrum analyzer is connected to the measuring antenna. A radiated measurement is performed. The RBW is set in the range of 1% to 5% of the occupied bandwidth, with VBW $\geq 3 \times$ RBW. The SPAN is wide enough to capture all products of the modulation process. A Peak detector is used. Measure is performed with OBW 99% function of the spectrum analyser. The tested equipment is set to transmit operation with modulation.</p>		Pass
Laboratory Parameters:	Required prior to the test	During the test
Ambient Temperature	20 to 30 °C	25°C \pm 2
Relative Humidity	30 to 70 %	45% \pm 5
Supplementary information: Test location: SMEE Test date: May 20 th , 2020		

Test Equipment Used					
Description	Manufacturer	Model	Identifier	Cal. Date	Cal. Due
Measuring Rec.	Rohde&Schwarz	ESRP	REC-151-002	2019/9	2021/9
Loop antenna	EMCO	6502	ANT-101-009	2019/8	2021/8
RF cable	HUBER+SUHNER	RG214U	CAB-141-026	2019/4	2020/6
RF cable	HUBER+SUHNER	RG214U	CAB-141-029	2019/4	2020/6
Anechoic chamber	COMTEST	214263	CAG-141-001	2017/6	2020/6

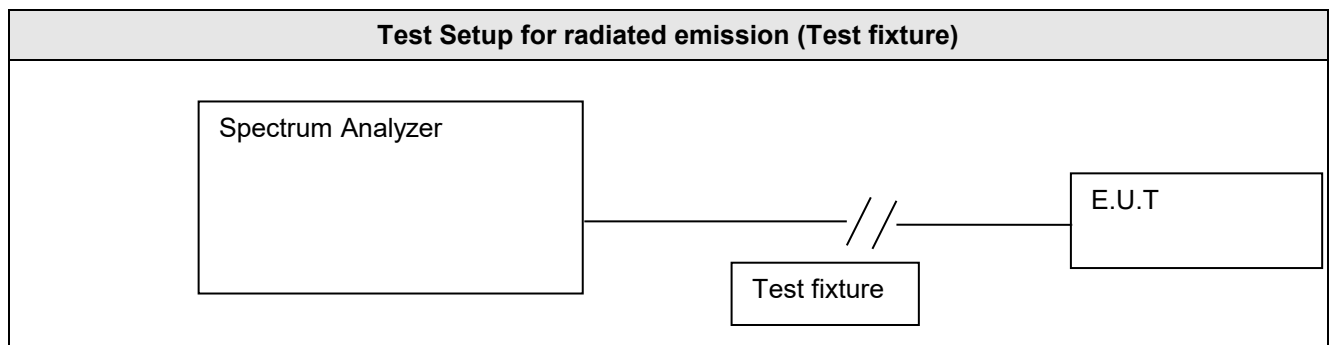

Tabulated Results for Occupied Bandwidth

Frequency (MHz)	99% Bandwidth (kHz)
13.56	424.033

Graphical representation of Occupied Bandwidth

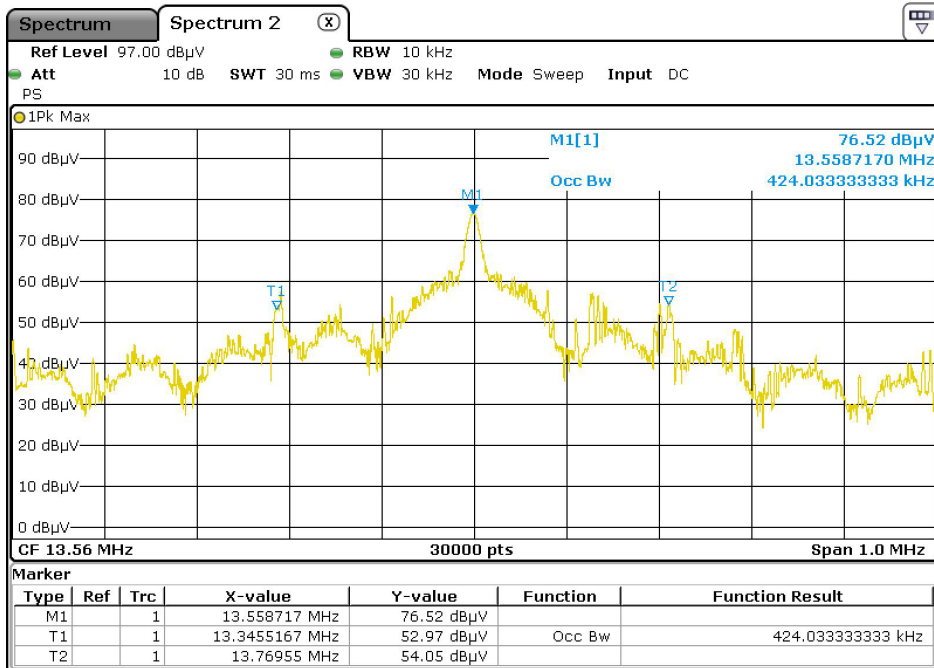

99% Occupied Bandwidth

Frequency:	13.56MHz
RBW / VBW:	10kHz / 30kHz
Measurement detector:	Peak