

FCC Test Firm Designation Number: FR0014
SED Wireless Device Testing Laboratory CAB Number: FR0004

Matériel testé : <i>Equipment under test:</i>	IDENDEC SOLUTIONS / IDS1001 (i-Point Si) <i>(Trademark / Marketing name or product reference)</i> UHF communication media (902-928MHz)
--	--

Client / Demandeur: **IDENDEC SOLUTIONS AG**
Customer / Applicant : Millennium Park 2
A-6890 Lustenau – Austria

Rapport délivré à : **IDENDEC SOLUTIONS AG**
Issued to: Karl-Heinz Feierle
Millennium Park 2
A-6890 Lustenau – Austria

Référence de la proposition : 012019-23396-1
Proposal number:

Numéro d'affaire : 12928
Work number :

Date de l'essai : Du 18 au 20 mai 2020
Date of test: May 18th to 20th, 2020

Objectif des essais : EMC qualification according to following standards:
Test purpose: - CFR 47, FCC Part 15, Subpart C
(Chapter 15.249 - Operation within the bands 902–928 MHz, 2400–2483.5 MHz, 5725–5875 MHz, and 24.0–24.25 GHz)
- Industry Canada, RSS-Gen Issue 5 & RSS-210 Issue 10, section B.10
(Bands 902–928, 2400–2483.5 and 5725–5875 MHz)
Measurement standards:
ANSI C63.10 (2013)

Lieu du test: SMEE, Rue de Taille
Test location: 38500 VOIRON - France

Test réalisé par : Laurent CHAPUS
Test realized by:

Conclusion : L'équipement satisfait aux prescriptions et essais des normes citées en référence.
Conclusion: *The appliance complies with requirements and tests of above mentioned standards.*

Ed.	Date	Modifications / Pages	Written by : Visa	Approved by: Visa
1	August 31 st , 2020	Initial Edition	Laurent CHAPUS	Regis ANCEL
2	December 7 th , 2020	TCB review	<i>Technical Manager</i>	<i>General Manager</i>

La copie de ce document n'est permise que sous sa forme intégrale. Ce document est le résultat d'essais effectués sur un échantillon. Il ne préjuge pas de la conformité de l'ensemble des produits fabriqués à l'objet essayé.

This document shall not be reproduced, except in full. This document contains results related only to the item tested. It does not imply the conformity of the whole production to the item tested.



Accréditation
N° 1-6356
Portée disponible sur :
Scope available on :
www.cofrac.fr

COORDONNEES

SMEE
Rue de Taille – ZI Des Blanchisseries
38500 VOIRON - France

TEL : 04 76 65 76 50
FAX : 04 76 66 18 30

SAS au capital de 50 000 € / RC Grenoble B534 796 453 / SIRET 534 796 453 00015 / code APE 7490B / n° TVA : FR 59 534 796 453

Contents

1. NORMATIVES REFERENCES	3
2. TEST SYNTHESIS.....	4
3. EQUIPMENT UNDER TEST (EUT).....	5
4. TEST CONDITIONS.....	5
5. MODIFICATIONS OF THE EUT.....	6
6. SPECIAL ACCESSORIES	6
7. MEASUREMENT UNCERTAINTY	6
8. FIELD STRENGTH CALCULATION.....	6
9. CONDUCTED EMISSION MEASUREMENT (150KHZ-30MHZ).....	7
10. FIELD STRENGTH OF FUNDAMENTAL.....	15
11. FIELD STRENGTH OF HARMONICS	18
12. UNWANTED EMISSIONS	21
13. OCCUPIED BANDWIDTH (99%).....	33

1. Normatives References

FCC qualification according to:		
Standards	Applied	Title
ANSI C63.10 (2013)	X	American National Standard for Testing Unlicensed Wireless Devices
CFR47, Part 15	X	Telecommunication – Federal Communication Commission – Radio frequency devices, Sections 15.207 / 15.209 / 15.249

Industry Canada qualification according to:		
Standards	Applied	Title
RSS-Gen (Issue 5/2019)	X	General Requirements and Information for the Certification of Radio Apparatus
RSS-210 (Issue10/2019)	X	Licence-exempt Radio Apparatus: Category I Equipment, Section B.10: Devices Operating in Frequency Bands for Any Application, Band 2400-2483.5MHz.

Deviation from standards: None.

2. Test synthesis

TEST	Paragraph number FCC Part 15 IC RSS-210	Spec. FCC Part 15 IC RSS-210	RESULTS (comments)
Conducted emissions test	15.207 (a) RSS-Gen: Issue 5, §8.8	15.207 (a) Table 4, §8.8	PASS
Field Strength of fundamental	15.249 (a) (c) RSS-210: Issue 9, §B.10 (a)	94dBµV/m @3m (50mV/m @ 3m)	PASS
Field Strength of harmonics	15.249 (a) (c) (e) RSS-210: Issue 9, §B.10 (a)	54dBµV/m @3m (0.5mV/m @ 3m)	PASS
Unwanted emissions outside the specified frequency band and harmonics	15.209 / 15.249 (d) (e) RSS-210: Issue 9, §B.10 (b) / RSS-Gen: Issue 5, §8.9	Whichever is less stringent, either: - 50dB below level of fundamental, or; - General field strength limits, as follow: <u>Measure at 300m</u> 9-490kHz: 2400µV/m/F(kHz) 6.370µA/m/F (kHz) <u>Measure at 30m</u> 0.490-1.705: 24000µV/m/F(kHz) 63.70µA/m/F (kHz) 1.705-30MHz: 30µV/m 0.08µA/m <u>Measure at 3m</u> 30MHz-88MHz : 40 dBµV/m 88MHz-216MHz : 43.5 dBµV/m 216MHz-960MHz : 46.0 dBµV/m Above 960MHz : 54.0 dBµV/m	PASS
Occupied Bandwidth	FCC Part 15.215 c) RSS-Gen: Issue 5, §6.7	BW at 99%	PASS

NA: Not Applicable

• General conclusion:

Measures and tests performed on the sample of the product **DENTEC SOLUTIONS / IDS1001**, in configuration and description presented in this test report, show compliance with standards FCC CFR 47, PART 15, Subpart C and Industry Canada RSS-Gen & RSS-210.

3. Equipment Under Test (EUT)

Nom /
Identification

IDENTEC SOLUTIONS / IDS1001
(i-Point Si)

(Trademark / Marketing name or product reference)

P/N: 455970 (IDS1001)
Sn: 2019PR0175

FCC ID:
IC:
Model:

OO4-IDS1001
IC : 3538A-IDS1001
IDS1001

Alimentation /
Power supply

24VDC from external power supply
Or POE (Power Over Ethernet)
Or USB (5V)

Auxiliaires /
Auxiliaries

- Laptop ASUS, model F200M
- 24V DC power supply DEUTRONIC ESC30-24 (SN: H957898 0003)

Entrées-Sorties /
Input / Output
US

	Câbles pour essai / Cables for test	Blindé / Shielded	Prévu pour >3m / Intended for >3m
RS422 (MASTER+24V)	2m	YES	YES
RS422 (SLAVE)	2m	YES	YES
LAN port (POE/ETH 100Mbps)	2m	YES	YES
USB port	1m *	YES	NO

(*: Debug only)

Mode de fonctionnement /
Running mode

Equipment running modes are:

The tested sample is able to be set in following modes:

- Transmit a modulated carrier frequency on low, middle and high channels (902.5/915/927.5MHz)

Equipment can be powered and can communicate with following configurations:

- 24V from external power supply / RS422 communication
- 24V from external power supply / Ethernet communication
- POE supply / Ethernet communication
- USB communication for debug mode

Version programme interne /
Firmware version

V101.21

Programme de test /
Test program /

PC test program "Gen3 Tag Certification tool" V.0.0.14512

Informations supplémentaires /
Additional informations

Declaration of the applicant:

- Type of technology: Proprietary RF protocol
- Emission bands: 902-928MHz
- Frequency transmission band: 902.5 to 927.5MHz.
- Baud rate can be set at 19200 / 38400/ 57600 / 115200 bps.
- Rated conducted output power: 0dBm for baud rates 115200 bps
- Rated conducted output power: +2dBm for baud rates 19200 / 38400/ 57600 bps
- Equipment intended for use as a fixed station
- Equipment designed for continuous operation
- Antenna type: PCB trace antenna

Dimensions de l'EST /
Dimensions of EUT

224mm x 214 x 46

4. Test conditions

Power supply voltage:

24V DC

Equipment under test:

230V/50Hz (Radiated emission)

Auxiliaries (AC mains):

110V/60Hz (Conducted emission)

5. Modifications of the EUT

None.

6. Special accessories

None required for compliance with emission limits.

7. Measurement Uncertainty

Test Description	Expanded uncertainty
Conducted emissions test (150k-30MHz, AC mains)	± 3.5dB
Radiated emission test (9kHz-30MHz, electric field)	± 4.0dB
Radiated emission test (30-300MHz, OATS)	± 5.6dB
Radiated emission test (300-1000MHz, OATS)	± 5.3dB
Radiated emission test (1-40GHz, OATS / FAC)	± 5.6dB
Conducted RF output power at antenna port	± 1.6dB
Radiated RF output power (Peak, Power density)	± 5.6dB
DTS Bandwidth, 99% OBW	±4%
Temperature	± 1°C
Time and duty cycle calculation	±1%
AC and DC voltage	±1%

Note: Expanded uncertainty at 95% confidence (k=2)

8. Field Strength Calculation

The field strength (level) is calculated by adding the Antenna Factor and Cable Factor, and subtracting the Amplifier Gain (if any) from the measured reading. The basic equation is as follow:

$$FS = RA + AF + CF - AG$$

Where FS = Field Strength (Level)

RA = Receiver Amplitude (Meter Reading)

AF = Antenna Factor

CF = Cable Factor

AG = Amplifier Gain

Total factor = AF+CF-AG

Margin value = Emission level – Limit value

Example:

RA: 14.0dBμV / AF: 16.5 dBm⁻¹ / CF: 3.5dB / AG: 15dB

→ Total factor: 5dBm⁻¹

→ Field level: 19.0dBμV/m (-21.0dB for margin if limit is 40dBμV/m)

9. Conducted Emission Measurement (150kHz-30MHz)

TEST: Limits for conducted disturbance 150kHz – 30MHz				Verdict	
<p><u>Method:</u> The LISN is placed 0,8 m from the boundary of the unit under test and bonded to a ground reference plane. This distance was between the closest points of the AMN and the EUT. All other units of the EUT and associated equipment were at least 0,8 m from the AMN. All power was connected to the system through Artificial Mains Network (AMN). Conducted voltage measurements on lines were made at the output of the LISN. The EUT is 80cm above the ground reference plane and 40cm from the vertical ground plane. The AC power cable is 1m length.</p>				Pass	
Laboratory Parameters:		Required prior to the test		During the test	
Ambient Temperature		20 to 30 °C		25°C ± 2	
Relative Humidity		25 to 70 %		45% ± 5	
Fully configured sample scanned over the following frequency range		Frequency range on each side of line		Measurement Point	
		150kHz to 30MHz		AC input port (110V)	
Limits					
Frequency (MHz)	Limit dB (µV)				
	Quasi-Peak	Result	Average	Result	
0.15 – 0.50	66 \ 56	PASS	56 \ 46	PASS	
0.50 - 5	56	PASS	46	PASS	
5 – 30	60	PASS	50	PASS	
Supplementary information:					
Test location: SMEE					
Test date: May 20 th , 2020. Tested by L. CHAPUS					
Power supply voltage: 15V/DC from external power supply (AC mains 110V/60Hz)					

Test Equipment Used					
Description	Manufacturer	Model	Identifier	Cal. Date	Cal. Due
AC power supply	PACIFIC POWER	AMX-125	ALI-101-002	-	-
Attenuator / limiter	SMEE	ATT#2	ATT-171-010	2019/6	2020/6
Cable RF	Div	1m	CAB-101-021	2020/4	2021/4
Measuring receiver	Rohde&Schwarz	ESRP	REC-151-002	2019/9	2021/9
LISN (50Ω / 50µH) (Meas.)	AFJ	LS16C	RSI-101-001	2019/6	2021/6
LISN (50Ω / 50µH) (Aux.)	AFJ	LS16C	RSI-111-002	2019/6	2021/6
EMC Software	NEXIO	BAT EMC V3.18	SOF-101-001	-	-

Test Setup for conducted emission

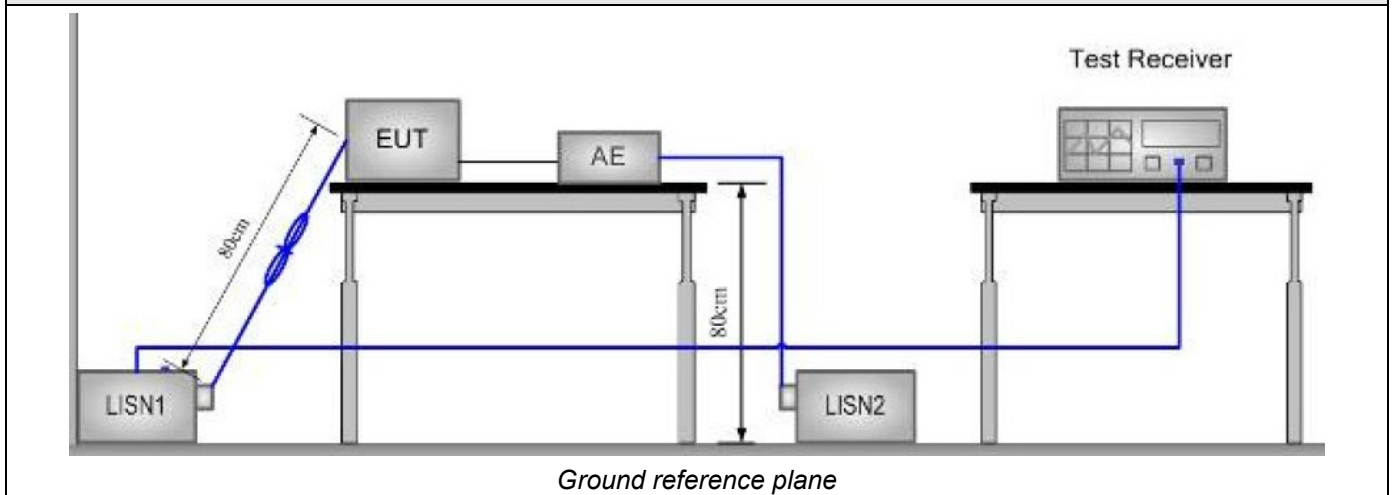

Tabulated Results for Mains Terminal Disturbance Voltage on AC port (RS422+24V, LF+NFC+UHF)

FREQ (MHz)	Meas. PK (dBμV)	Mes. QP (dBμV)	LIMIT QP (dBμV)	Margin QP (dB)	Mes. AV (dBμV)	LIMIT AV (dBμV)	Margin AV (dB)	Line
0.162	60.86	51.83	65.36	-13.53	29.33	55.36	-26.04	L1
0.178	59.55	50.88	64.58	-13.69	35.41	54.58	-19.17	L1
0.462	49	45.71	56.66	-10.95	38.8	46.66	-7.86	L1
0.822	43.58	31.58	56	-24.42	22.2	46	-23.8	L1
1.256	46.49	33.46	56	-22.54	21.37	46	-24.63	L1
2.016	45.74	33.03	56	-22.97	20.54	46	-25.46	L1
7.376	45.61	42.63	60	-17.37	35.38	50	-14.62	L1
13.56	51.82	51.41	60	-8.59	50.46	50	0.46	L1 (1)
13.56	45.76	44.57	60	-15.43	45.88	50	-4.12	L1 (2)
24.876	56.12	55.15	60	-4.85	46.68	50	-3.32	N
0.158	60.89	52	65.57	-13.57	30.56	55.57	-25.01	N
0.454	49.83	46.11	56.8	-10.69	38.95	46.8	-7.85	N
1.62	43.96	33.31	56	-22.69	22.66	46	-23.34	N
2.104	44.29	32.82	56	-23.18	21.27	46	-24.73	N
13.56	51.44	50.96	60	-9.04	50	50	0	N (1)
13.56	45.82	44.21	60	-15.79	45.73	50	-4.27	N (2)
25.376	55.95	54.9	60	-5.1	46.46	50	-3.54	N
Frequency band investigated:	150kHz-30MHz							
RBW:	9kHz							
Voltage:	110V/60Hz							
Limit:	15.207 / RSS-GEN §8.8							
Final measurement detector:	Quasi-Peak and CISPR Average (AV)							
RESULT:	PASS							
Notes:	(1): NFC transmitter's fundamental emission band (2): Retest with a dummy load in lieu of the antenna							

Tabulated Results for Mains Terminal Disturbance Voltage on AC port (ETHERNET+24V, LF+NFC+UHF)

FREQ (MHz)	Meas. PK (dBμV)	Mes. QP (dBμV)	LIMIT QP (dBμV)	Margin QP (dB)	Mes. AV (dBμV)	LIMIT AV (dBμV)	Margin AV (dB)	Line
0.1572	61.18	52.36	65.57	-13.21	31.57	55.57	-24	L1
0.178	59.98	51.04	64.58	-13.54	39.76	54.58	-14.82	L1
0.334	50.34	38.85	59.35	-20.5	24.53	49.35	-24.82	L1
0.454	50.07	45.93	56.8	-10.88	38.74	46.8	-8.06	L1
1.244	45.5	32.02	56	-23.98	21.26	46	-24.74	L1
1.888	43.84	31.69	56	-24.31	20.12	46	-25.88	L1
2.928	44.05	32.05	56	-23.95	21.04	46	-24.96	L1
13.56	57.08	56.81	60	-3.19	55.91	50	5.91	L1 (1)
13.56	52.14	51.49	60	-8.51	45.41	50	-4.59	L1 (2)
30	51.17	49	60	-11	43.04	50	-6.96	L1
0.178	59.25	50.95	64.58	-13.63	41.13	54.58	-13.44	N
0.462	49.86	45.76	56.66	-10.9	38.95	46.66	-7.71	N
1.328	43.22	31.5	56	-24.5	22.95	46	-23.05	N
2.12	44.79	33.11	56	-22.89	21.45	46	-24.55	N
6.624	45.04	43.12	60	-16.88	35.58	50	-14.42	N
13.56	56.59	56.29	60	-3.71	55.29	50	5.29	N (1)
13.56	51.58	50.86	60	-9.14	44.55	50	-5.45	N (2)
30	50.19	48.34	60	-11.66	41.67	50	-8.33	N
Frequency band investigated:	150kHz-30MHz							
RBW:	9kHz							
Voltage:	110V/60Hz							
Limit:	15.207 / RSS-GEN §8.8							
Final measurement detector:	Quasi-Peak and CISPR Average (AV)							
RESULT:	PASS							
Notes:	(1): NFC transmitter's fundamental emission band (2): Retest with a dummy load in lieu of the antenna							

Tabulated Results for Mains Terminal Disturbance Voltage on AC port (POE, LF+NFC+UHF)								
FREQ	Meas. PK	Mes. QP	LIMIT QP	Margin QP	Mes. AV	LIMIT AV	Margin AV	Line
(MHz)	(dBμV)	(dBμV)	(dBμV)	(dB)	(dBμV)	(dBμV)	(dB)	
0.162	55.5	52.77	65.36	-12.59	34.5	55.36	-20.86	L1
0.226	47.48	41.96	62.6	-20.63	26.44	52.6	-26.15	L1
0.378	39.77	34.39	58.32	-23.93	23.45	48.32	-24.88	L1
4.948	42.25	37.3	56	-18.7	29.36	46	-16.64	L1
6.496	45.13	39.92	60	-20.08	33.13	50	-16.87	L1
13.56	51.09	50.39	60	-9.61	49.28	50	-0.72	L1
0.162	52.95	48.87	65.36	-16.49	32.57	55.36	-22.79	N
0.202	45.17	39.11	63.53	-24.42	19.73	53.53	-33.8	N
0.422	39.92	35.3	57.41	-22.11	27.66	47.41	-19.75	N
0.494	36.66	33.22	56.1	-22.88	22.05	46.1	-24.05	N
4.96	39.13	35.36	56	-20.64	28.7	46	-17.3	N
6.376	42.93	37.76	60	-22.24	31.73	50	-18.27	N
13.56	51.28	50.61	60	-9.39	49.56	50	-0.44	N
23.128	41.5	38.83	60	-21.17	32.84	50	-17.16	N
Frequency band investigated:			150kHz-30MHz					
RBW:			9kHz					
Voltage:			110V/60Hz					
Limit:			15.207 / RSS-GEN §8.8					
Final measurement detector:			Quasi-Peak and CISPR Average (AV)					
RESULT:			PASS					

Tabulated Results for Mains Terminal Disturbance Voltage on AC port (USB, LF+NFC+UHF)								
FREQ	Meas. PK	Mes. QP	LIMIT QP	Margin QP	Mes. AV	LIMIT AV	Margin AV	Line
(MHz)	(dBμV)	(dBμV)	(dBμV)	(dB)	(dBμV)	(dBμV)	(dB)	
0.174	57.02	54.17	64.77	-10.59	40	54.77	-14.77	L1
0.23	52.09	48.6	62.45	-13.85	35.59	52.45	-16.86	L1
13.56	62.81	62.04	60	2.04	61.21	50	11.21	L1 (1)
13.56	49.56	49.21	60	-10.79	48.54	50	-1.46	L1 (2)
0.174	53.36	51.55	64.77	-13.22	36.75	54.77	-18.02	N
0.238	49.02	46.4	62.17	-15.76	34.13	52.17	-18.04	N
13.56	62.88	62.1	60	2.1	61.29	50	11.29	N (1)
13.56	49.23	48.94	60	-11.06	48.13	50	-1.87	N (2)
Frequency band investigated:			150kHz-30MHz					
RBW:			9kHz					
Voltage:			110V/60Hz					
Limit:			15.207 / RSS-GEN §8.8					
Final measurement detector:			Quasi-Peak and CISPR Average (AV)					
RESULT:			PASS					
Notes:			(1): NFC transmitter's fundamental emission band (2): Retest with a dummy load in lieu of the antenna					
Measured value calculation:			<p>The measured value (level) is calculated by adding the Cable Factor, the Transient suppressor attenuation and LISN attenuation from the receiver amplitude reading. The basic equation is as follow:</p> $\text{Meas.} = \text{RA} + \text{CF} + \text{ATT}_{\text{TRAN}} + \text{ATT}_{\text{LISN}}$ <p>Where Meas. = Level (dBμV) RA = Receiver Amplitude CF = Cable Factor ATT_{TRAN} = Transient suppressor attenuation ATT_{LISN} = LISN attenuation</p> <p>Margin value = Emission level – Limit value (A negative margin shows compliance to limit)</p>					

Graphical representation of Conducted Disturbance Measurement (Peak and Average detection) AC port, Line L1 (RS422+24V)

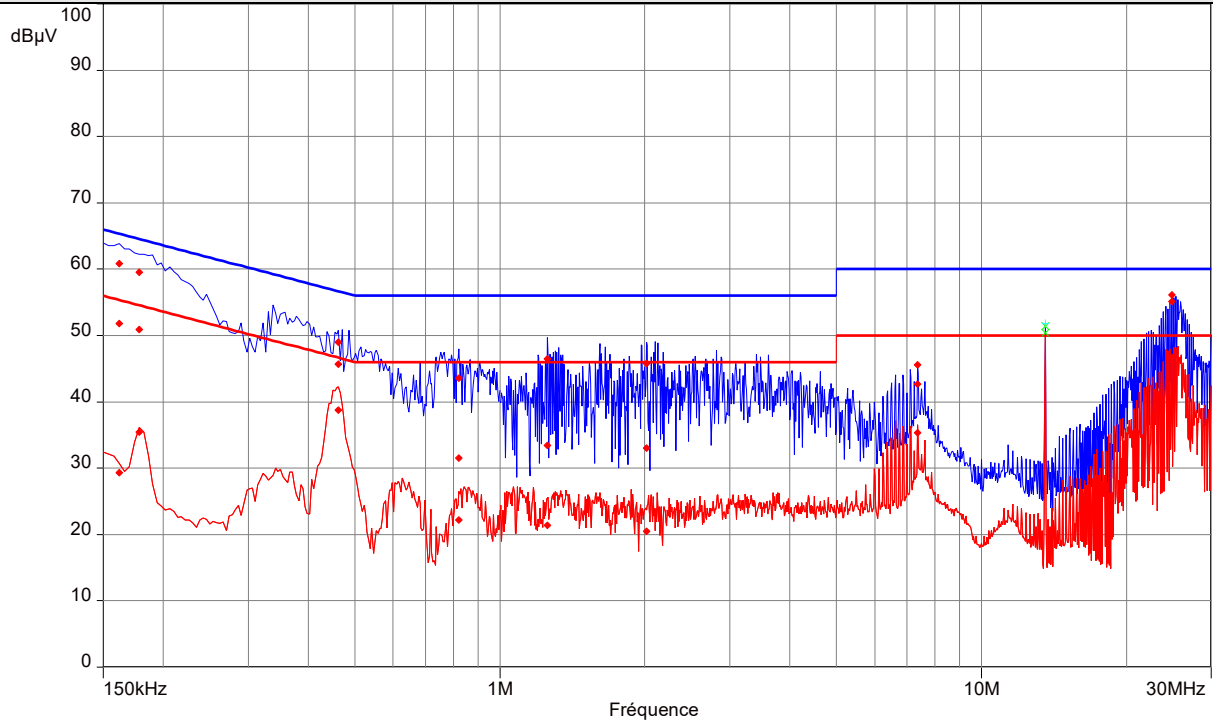

----: Peak

----: Average

Graphical representation of Conducted Disturbance Measurement (Peak and Average detection) AC port, Line Neutral (RS422+24V)

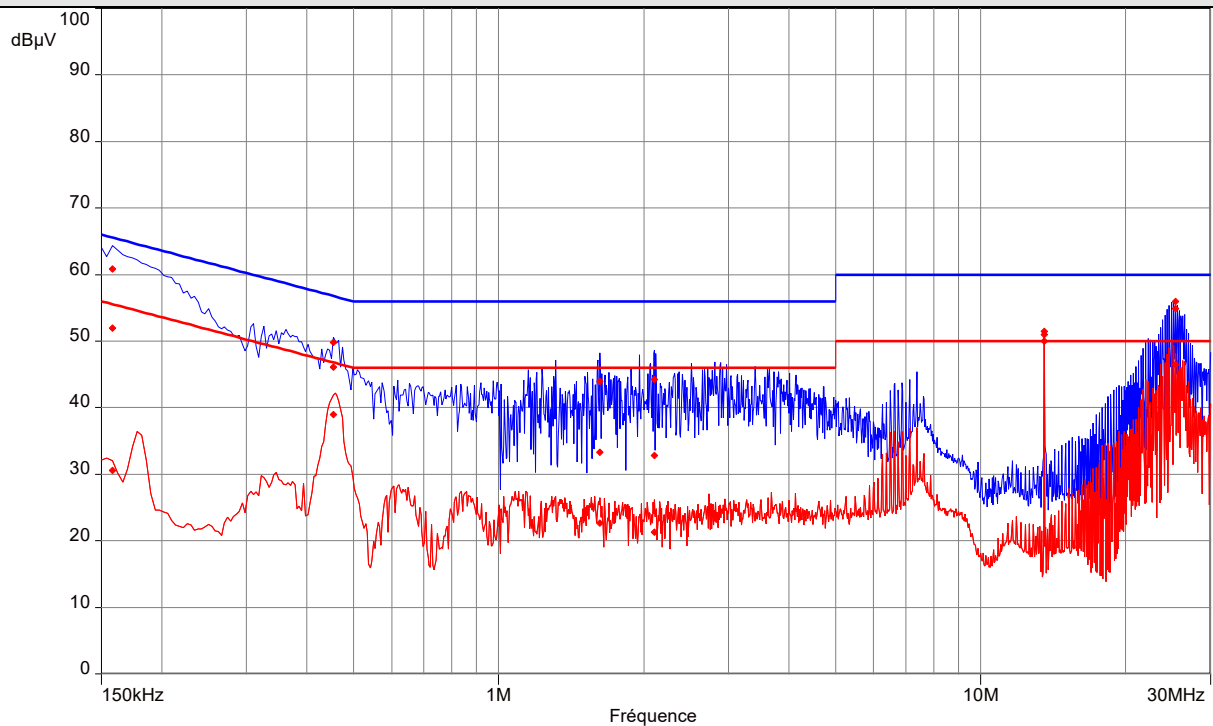

----: Peak

----: Average

Graphical representation of Conducted Disturbance Measurement (Peak and Average detection) AC port, Line L1 (ETH+24V)

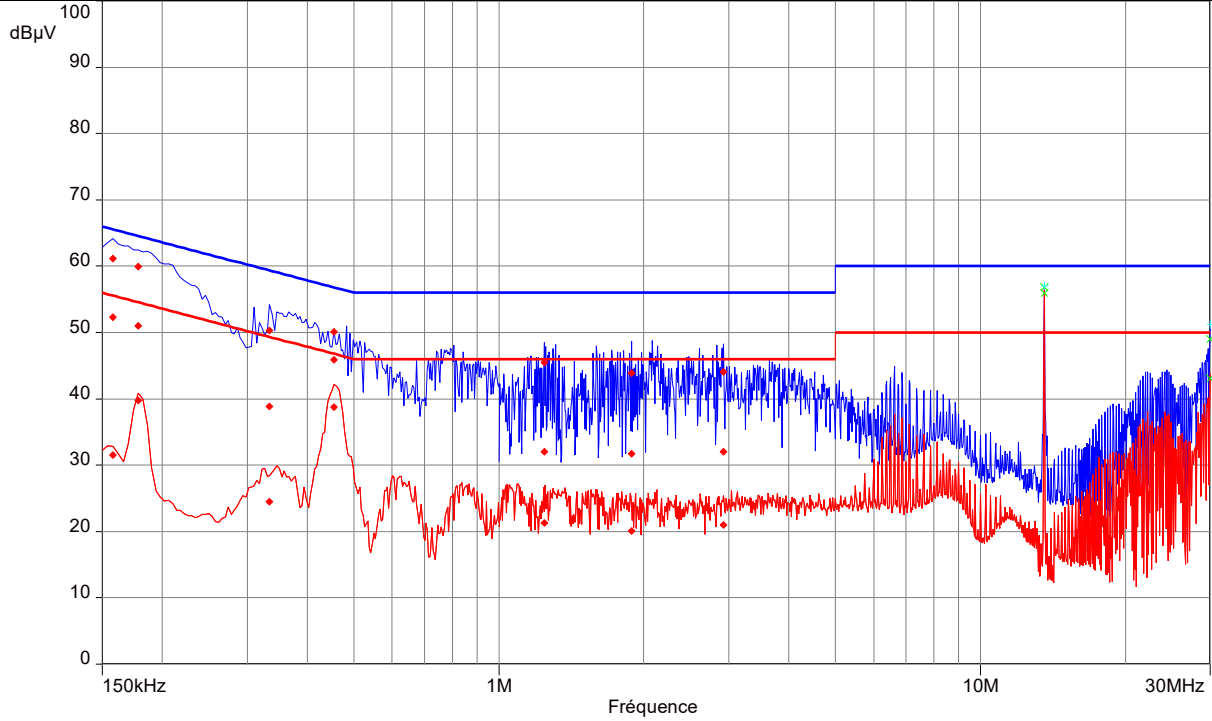

----: Peak

----: Average

Graphical representation of Conducted Disturbance Measurement (Peak and Average detection) AC port, Line Neutral (ETH+24V)

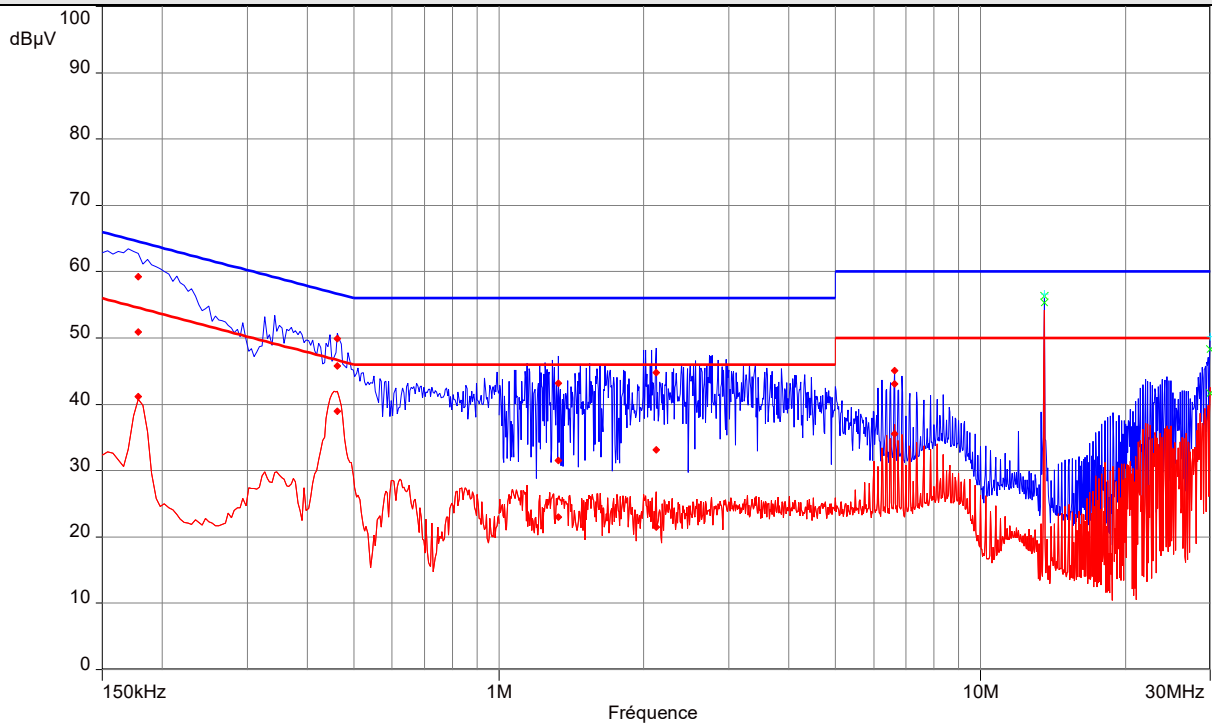

----: Peak

----: Average

Graphical representation of Conducted Disturbance Measurement (Peak and Average detection) AC port, Line L1 (POE)

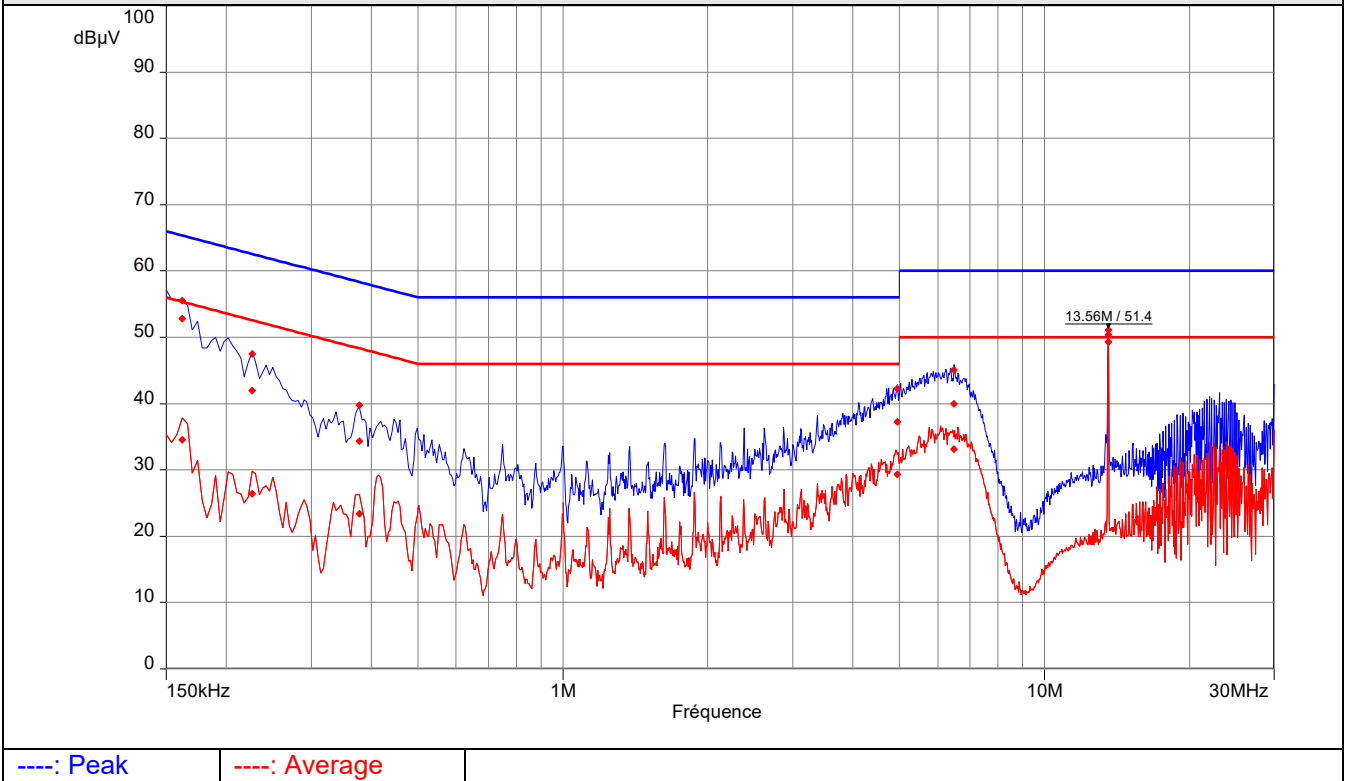

Graphical representation of Conducted Disturbance Measurement (Peak and Average detection) AC port, Line Neutral (POE)

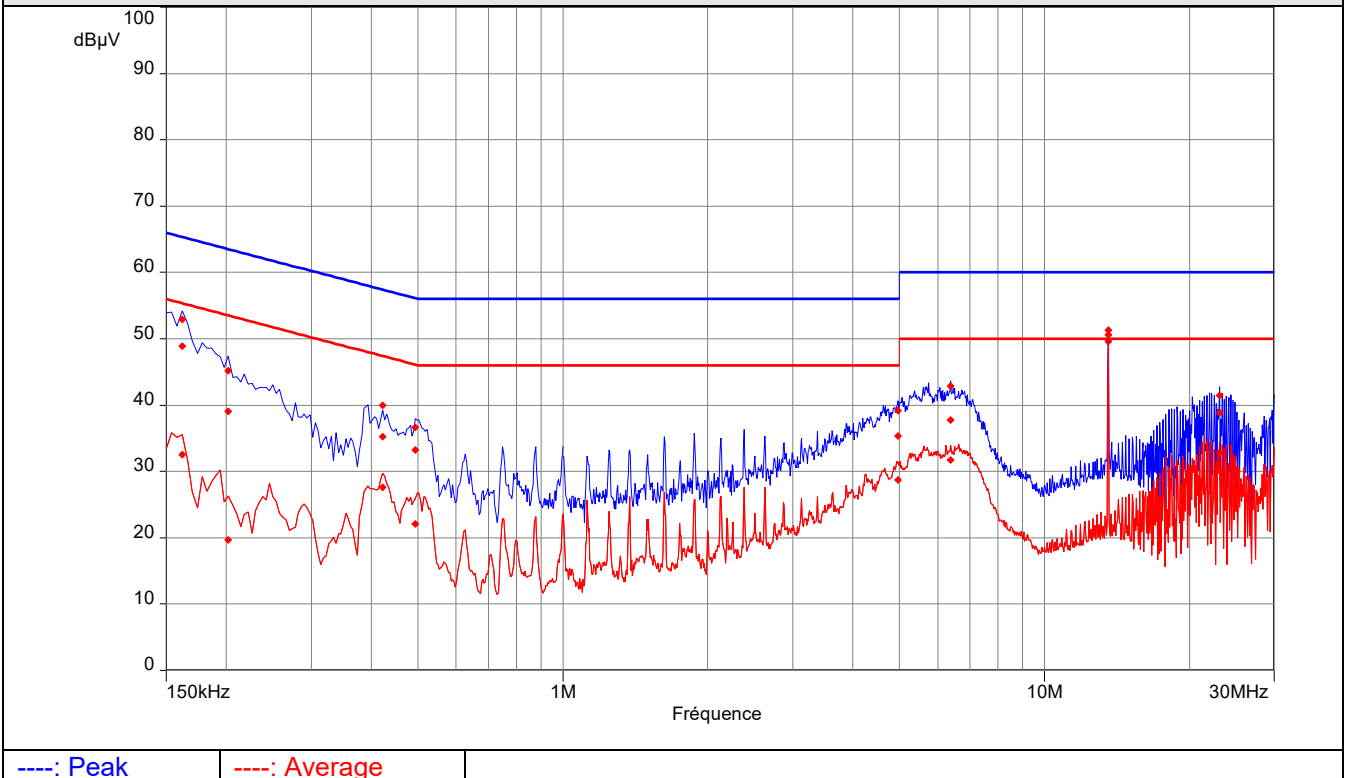

Graphical representation of Conducted Disturbance Measurement (Peak and Average detection) AC port, Line L1 (USB)

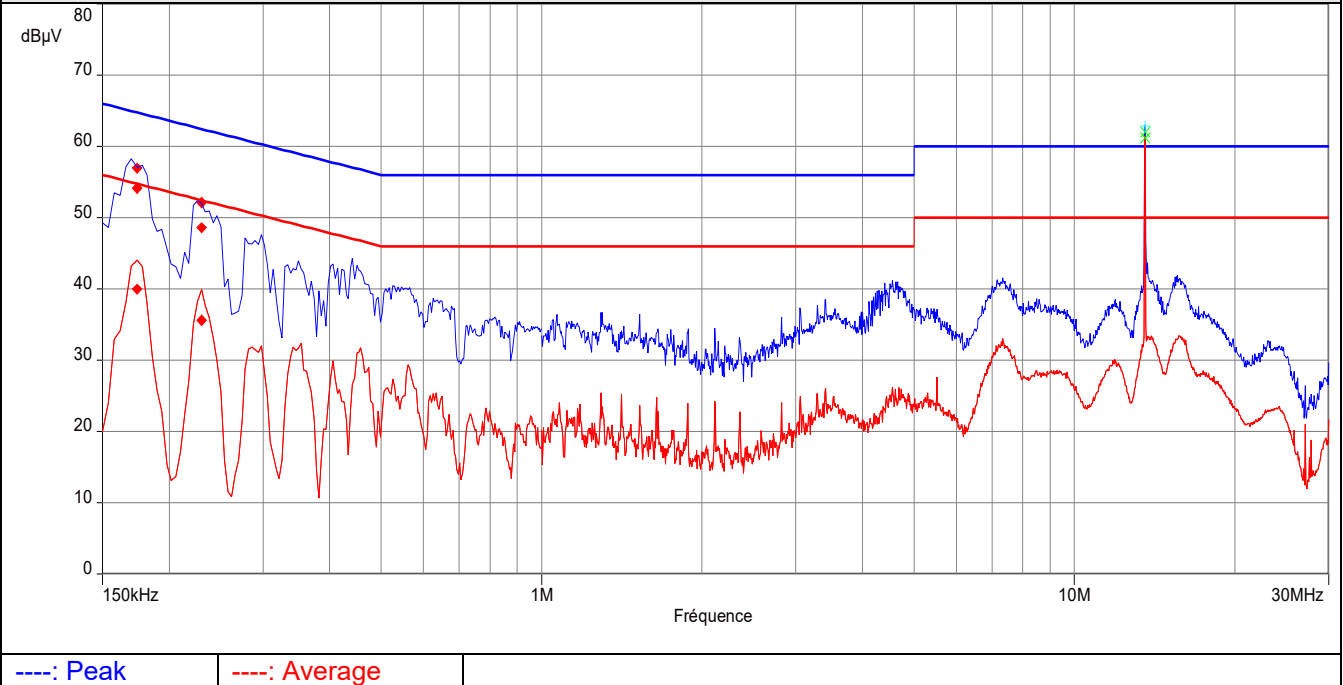

Graphical representation of Conducted Disturbance Measurement (Peak and Average detection) AC port, Line Neutral (USB)

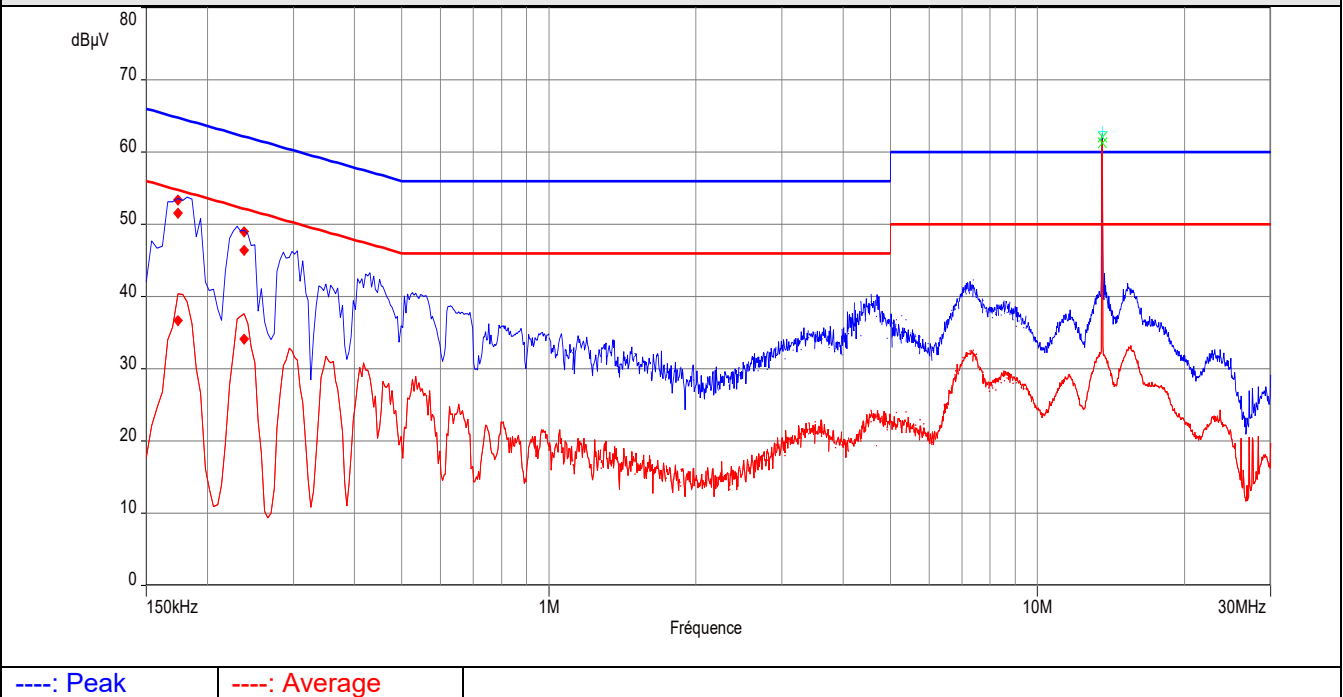

10. Field Strength of fundamental

TEST: Field strength of fundamental / FCC part 15.249 – RSS 210 §B.10		Verdict
<p><u>Method:</u> Measurements were made in a 3-meter Open Area Test Site (OATS) that complies to ANSI C63.4 / C63.10. Measurements were performed with a quasi-peak detector using a 120kHz RBW. The EUT was rotated 360° about its azimuth with the receive antenna located at various heights in horizontal and vertical polarities. Final measurements (Quasi-Peak) were then performed by rotating the EUT 360° and adjusting the receive antenna height from 1 to 4 m. The tested equipment is set to transmit operation with modulation on lowest, middle and highest channels. Three orthogonal axis measurements on EUT are performed to obtain the maximum peak field strength.</p>		Pass
Laboratory Parameters:	Required prior to the test	During the test
Ambient Temperature	20 to 30 °C	25°C ± 2
Relative Humidity	30 to 70 %	45% ± 5
Limits – FCC Part 15.249 (a) (c) / RSS-210 §B.10 (a)		
Frequency (MHz)	Limits (dBµV/m)	
	Level / Detector / Distance	Results
902 to 928 MHz	94dBµV/m / Pk / 3m	Pass
Supplementary information: Test location: SMEE Test date: May 18 th , 2020. Tested by L. Chapus		

Test Equipment Used					
Description	Manufacturer	Model	Identifier	Cal. Date	Cal. Due
Log-periodic antenna	EMCO	3146	ANT-191-019	2019/6	2021/6
RF cable	Div	OATS/25m	CAB-101-017	2020/4	2021/4
OATS	Div	10/3m	SIT-101-001	2017/7	2020/7
Antenna mast	Innco- Systems	MA4000EP	MAT-101-001	-	-
Turntable	Innco- Systems	DS1200S	PLA-101-001	-	-
Measuring Receiver	Rohde&Schwarz	ESRP	REC-151-002	2019/9	2021/9
EMC Software	NEXIO	BAT EMC V3.18	SOF-101-001	-	-

Test Setup for radiated emission

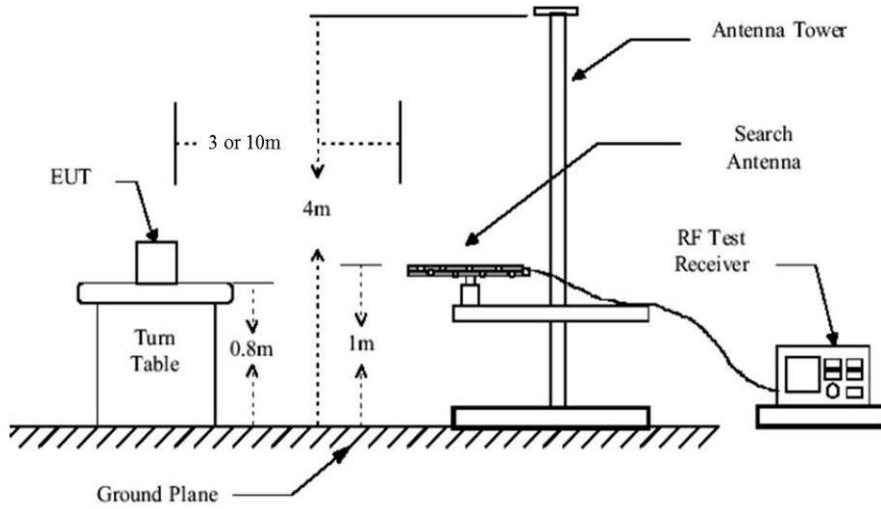

Test setup for 30-1000MHz (3m)

Tabulated Results for Field Strength of fundamental (Ant1 / 115200bps)

FREQ (MHz)	Field Strength @ 3m (dB μ V/m)	Detector	Limit (dB μ V/m)	Margin dB	Result
902.5	91.8	QP	Pass	-2.2	Pass
915.0	91.4	QP	Pass	-2.6	Pass
927.5	90.4	QP	Pass	-3.6	Pass

Note: P_{OUT} is set at 0dBm

Tabulated Results for Field Strength of fundamental (Ant1 / 19200bps)

FREQ (MHz)	Field Strength @ 3m (dB μ V/m)	Detector	Limit (dB μ V/m)	Margin dB	Result
902.5	93.1	QP	Pass	-0.9	Pass
915.0	92.7	QP	Pass	-1.3	Pass
927.5	91.4	QP	Pass	-2.6	Pass

Note: P_{OUT} is set at 2dBm

Tabulated Results for Field Strength of fundamental (Ant2 / 115200bps)

FREQ	Field Strength @ 3m	Detector	Limit	Margin	Result
(MHz)	(dB μ V/m)		(dB μ V/m)	dB	
902.5	91.6	QP	Pass	-2.4	Pass
915.0	91.8	QP	Pass	-2.2	Pass
927.5	90.7	QP	Pass	-3.3	Pass

Note: P_{OUT} is set at 0dBm

Tabulated Results for Field Strength of fundamental (Ant2 / 19200bps)

FREQ	Field Strength @ 3m	Detector	Limit	Margin	Result
(MHz)	(dB μ V/m)		(dB μ V/m)	dB	
902.5	93.3	QP	Pass	-0.7	Pass
915.0	93.9	QP	Pass	-0.1	Pass
927.5	93.7	QP	Pass	-0.3	Pass

Note: P_{OUT} is set at 2dBm

RBW:	120kHz
Measurement distance:	3m
Limit:	FCC Part 15.249 (a) (c) / RSS-210 §B.10
Final measurement detector:	Quasi-Peak
RESULT:	PASS
Note:	Worst case results for all communication modes

11. Field Strength of harmonics

TEST: Field Strength of harmonics / FCC part 15.249 – RSS-210 §B.10		Verdict
<p><u>Method:</u> For frequency above 1GHz, final measurements are made in a Full Anechoic Chamber (FAC) that complies with ANSI C63.10. Measurements were performed at an antenna to EUT separation distance of 3 meter. The EUT was rotated 360° about its azimuth with the receive antenna in horizontal and vertical polarities.</p> <p>Three orthogonal axis measurements on EUT are performed to obtain the maximum peak field strength, with 60° rotation on each axis.(Clause 6.6.5 of ANSI C63.10).</p> <p>A pre-scan frequency identification of the EUT has been performed in full anechoic chamber. The measured radiated field of the EUT is performed (or corrected) at 3-meters of distance. Antenna is 1.5-meters high. The pre-characterization graphs are obtained in PEAK and Average detection with 360° continuous rotation of the device under test.</p>		Pass
Laboratory Parameters:	Required prior to the test	During the test
Ambient Temperature	20 to 30 °C	25°C ± 2
Relative Humidity	30 to 70 %	45% ± 5
Fully configured sample scanned over the following frequency range	Frequency range on each side of line	Measurement Point
	30MHz – 10GHz	3 m measurement distance
Limits – FCC Part 15.249 (a) (c) (e) / RSS-210 §B.10 (a)		
Frequency bands for harmonics (MHz)	Limits (dBµV/m)	
	Level / Detector / Distance	Results
4800 to 4967	54.0 / AV / 3m 74.0 / PK / 3m	Pass
7200 to 7450.5	54.0 / AV / 3m 74.0 / PK / 3m	Pass
9600 to 9934	54.0 / AV / 3m 74.0 / PK / 3m	Pass
12000 to 12417.5	54.0 / AV / 3m 74.0 / PK / 3m	Pass
14400 to 14901	54.0 / AV / 3m 74.0 / PK / 3m	Pass
16800 to 17384.5	54.0 / AV / 3m 74.0 / PK / 3m	Pass
19200 to 19868	54.0 / AV / 3m 74.0 / PK / 3m	Pass
21600 to 22351.5	54.0 / AV / 3m 74.0 / PK / 3m	Pass
24000 to 24835	54.0 / AV / 3m 74.0 / PK / 3m	Pass
Supplementary information:		
Test location: SMEE		
Test date: May 18 th , 2020. Tested by L. Chapus		

Test Equipment Used					
Description	Manufacturer	Model	Identifier	Cal. Date	Cal. Due
Horn antenna	ETS-LINDGREN	3115	ANT-141-013	2018/10	2021/10
Spectrum analyzer	Rohde&Schwarz	FSV40	ASP-171-004	2019/8	2021/8
RF cable	Pasternack RF	PE302-120	CAB-131-024	2019/4	2020/6
RF cable	HUBER+SUHNER	SF104	CAB-141-030	2019/4	2020/6
Anechoic chamber	COMTEST	214263	CAG-141-001	2017/6	2020/6
Antenna mast	Innco- Systems	MA4000EP	MAT-101-001	-	-
Turntable	Innco- Systems	DS1200S	PLA-101-001	-	-
Turntable	Innco- Systems	CT0800	PLA-141-001		
Pre-amplifier	PE	1524	PRE-101-002	2019/6	2020/6
Measuring receiver	Rohde&Schwarz	ESRP	REC-151-003	2019/9	2021/9
EMC Software	NEXIO	BAT EMC V3.18	SOF-101-001	-	-

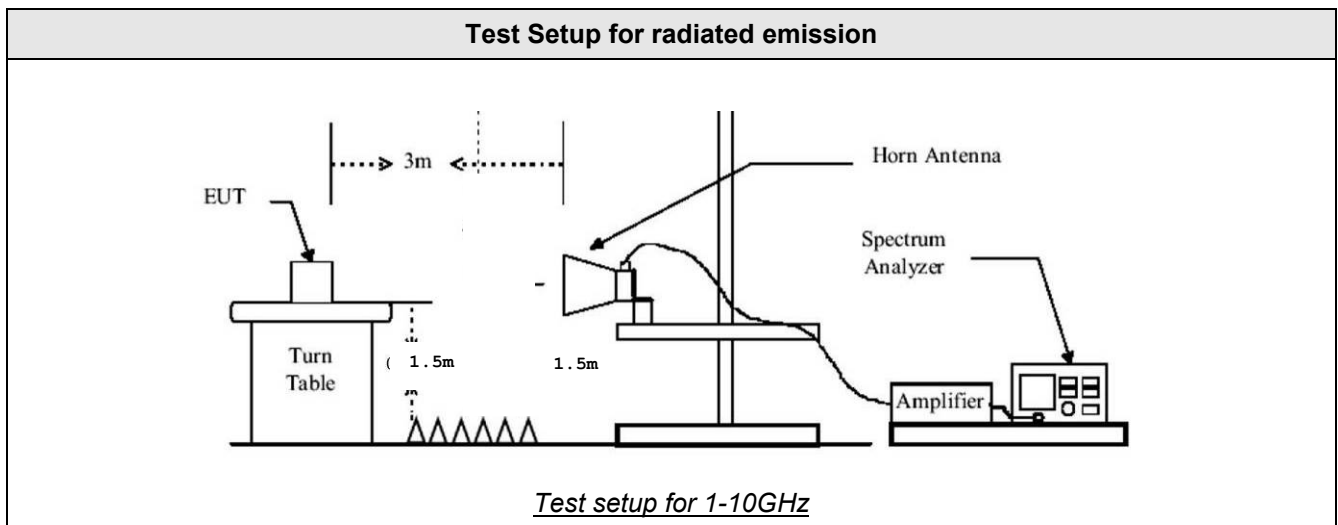

Tabulated Results for Field strength of harmonics (1GHz-9.3GHz)				
FREQ (MHz)	Field level dB μ V/m	Detector	Limit (dB μ V/m)	Result
Levels at least 10dB below limits		Pk	74.0	Pass
Levels at least 10dB below limits		Av	54.0	Pass
RBW	1MHz			
Measurement distance:	3m			
Limit:	FCC Part 15.249 (a) (c) (e)			
Final measurement detector:	Peak / Average			
RESULT:	PASS			
Notes:	(1): See pre-scan graphs in chapter 12 (Unwanted emission)			

12. Unwanted emissions

TEST: Unwanted emissions outside fundamental and harmonics bands / FCC part 15.209, 15.249 - RSS-210 §B.10 / RSS-Gen §8.9		Verdict
<p>Method: Measurements were made in a 3-meter Open Area Test Site that complies to ANSI C63.4/ C63.10 for frequency below 1GHz. Measurements were made in a 3-meter Full Anechoic Chamber (FAC) that complies to ANSI C63.10 for frequency above 1GHz.</p> <p>The EUT was rotated 360° about its azimuth with the receive antenna located at various heights in horizontal and vertical polarities. Final measurements (Peak/Quasi-Peak/Average) were then performed by rotating the EUT 360° and adjusting the receive antenna height.</p> <p>The tested equipment is set to transmit operation with modulations on lowest, middle and highest channel. Three orthogonal axis measurements on EUT are performed to obtain the maximum peak field strength. A pre-scan frequency identification of the EUT has been performed in full anechoic chamber. The measured radiated field of the EUT is performed at 3-meters of distance for frequency 9k-1GHz. The measured radiated field of the EUT is performed at 1.6-meters of distance for frequency 1-25GHz. Antenna is 1.25m (Freq < 1GHz) or 1.5m (Freq < 1GHz) high in front of EUT.</p>		Pass
Laboratory Parameters:	Required prior to the test	During the test
Ambient Temperature	20 to 30 °C	25°C ± 2
Relative Humidity	30 to 70 %	45% ± 5
Fully configured sample scanned over the following frequency range	Frequency range on each side of line	Measurement Point
	9kHz – 30MHz	10 m measurement distance
	30MHz – 10GHz	3 m measurement distance
Limits – FCC Part 15.209, 15.249 (d) (e) / RSS-Gen §8.9, RSS-210 §B.10 (b)		
Whichever is less stringent, either:		
Frequency (MHz)	Limits (dBµV/m)	
	Level / Detector / Distance	Results
30 to 1000	50dB below the fundamental / QP / 3m	Not used
Above 1GHz	50dB below the fundamental / Av / 3m 30dB below the fundamental / Pk / 3m	Not used
Or		
Frequency (MHz)	Limits (dBµV/m)	
	Level / Detector / Distance	Results
0.009 to 0.090	107.6 – 87.6 / AV / 10m 127.6 – 107.6 / PK / 10m	Pass
0.090 to 0.110	87.6 – 85.9 / QP / 10m	Pass
0.110 to 0.490	85.7 – 72.9 / AV / 10m 105.7 – 92.9 / PK / 10m	Pass
0.490 to 1.705	52.9 – 42.1 / QP / 10m	Pass
1.705 to 30	48.6 / QP / 10m	Pass
30 to 88	40.0 / QP / 3m	Pass
88 to 216	43.5 / QP / 3m	Pass
216 to 960	46.0 / QP / 3m	Pass
960-1000	54.0 / QP / 3m	Pass

Above 1GHz	54.0 / AV / 3m 74.0 / PK / 3m	Pass
Supplementary information: Test location: SMEE Test date: May 18 th , 2020. Tested by L. Chapus		

Test Equipment Used					
Description	Manufacturer	Model	Identifier	Cal. Date	Cal. Due
Log-periodic antenna	EMCO	3146	ANT-191-019	2019/6	2021/6
Biconnic antenna	COM-POWER	AB- 900	ANT-101-003	2019/6	2021/6
Loop antenna	EMCO	6502	ANT-101-009	2019/8	2021/8
BiConiLog antenna	EMCO	3142B	ANT-101-010	2019/8	2021/8
Horn antenna	ETS-LINDGREN	3115	ANT-141-013	2018/10	2021/10
Horn antenna	ETS-LINDGREN	3116	ANT-161-014	2017/12	2022/12
Spectrum analyzer	Rohde&Schwarz	FSV40	ASP-171-004	2019/8	2021/8
RF cable	Div	OATS/25m	CAB-101-017	2020/4	2021/4
RF cable	Pasternack RF	PE302-120	CAB-131-024	2019/4	2020/6
RF cable	HUBER+SUHNER	RG214U	CAB-141-026	2019/4	2020/6
RF cable	HUBER+SUHNER	RG214U	CAB-141-029	2019/4	2020/6
RF cable	HUBER+SUHNER	SF104	CAB-141-030	2019/4	2020/6
Pre-amplifier	Pasternack RF	PE1524	PRE-101-002	2019/6	2020/6
Anechoic chamber	COMTEST	214263	CAG-141-001	2017/6	2020/6
OATS	Div	10m	SIT-101-001	2017/7	2020/7
Antenna mast	Innco- Systems	MA4000EP	MAT-101-001	-	-
Turntable	Innco- Systems	DS1200S	PLA-101-001	-	-
Turntable	Innco- Systems	CT0800	PLA-141-001	-	-
Measuring Rec	Rohde&Schwarz	ESRP	REC-151-002	2019/9	2021/9
EMC Software	NEXIO	BAT EMC V3.18	SOF-101-001	-	-

Test Setup for radiated emission

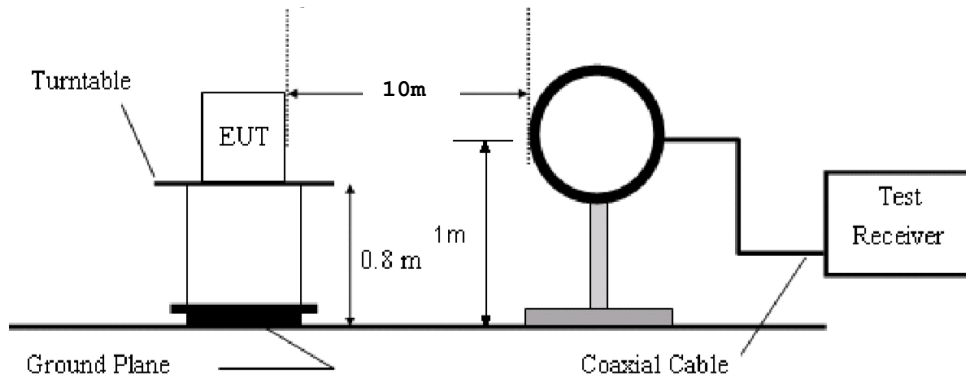

Test setup for 9k-30MHz

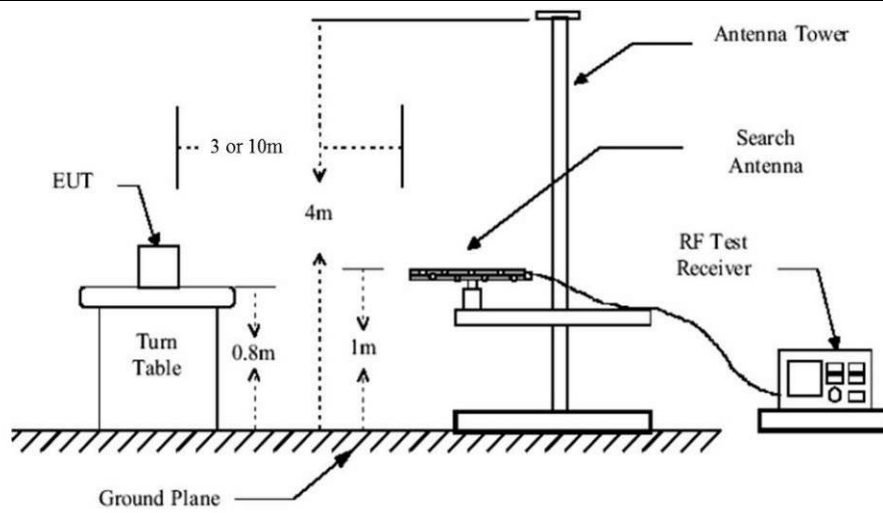

Test setup for 30-1000MHz (3m)

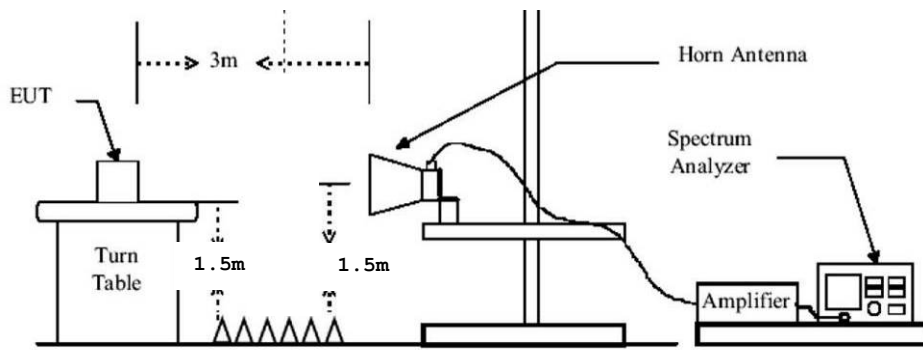

Test setup for 1-10GHz

Tabulated Results for Unwanted emissions (9kHz-30MHz)							
FREQ	RF field @ 30m	Limit @ 30m	Margin	Antenna		Table angle	Correc. Fact. (CF)
MHz	(QP) dBµV/m	(QP) dBµV/m	dB	Angle (Degree)	Position	Degree	dB
Levels are at least 10dB below limits							
Supplementary information: Frequency list measured on the Open Area Test Site has been created with pre-scan results.							
Frequency band investigated:		9kHz-30MHz					
RBW:		200Hz (9kHz-150kHz) 9kHz (150kHz-30MHz)					
Measurement distance:		10m					
Limit:		FCC Part 15.209 – 15.249 / RSS-Gen §8.9 – RSS-210 §B.10 (b)					
Final measurement detector:		Peak / Quasi-Peak / Average					
Note:		CF: Correction factor = Antenna factor + Cable loss Measure have been done at 10m distance and corrected according to requirements of 15.209.e) M@300m = M@10m-59.1dB / M@30m = M@10m-19.1dB					

Tabulated Results for Radiated Disturbance (3m measurement on Open Area Test Site, 30MHz-1GHz)										
FREQ	Meter reading	Meter reading	Total Factor	Field level	Field level	Pol	Antenna height	Table angle	Limit	Margin
MHz	(QP) dBµV	(Pk) dBµV	dB	(QP) dBµV/m	(Pk) dBµV/m		cm	Degré	(QP) dBµV/m	dB
56.580	22.3	26.9	10.3	32.6	37.2	V	100	160	40	-7.4
166.980	21.1	26.1	15.4	36.5	41.5	V	100	140	43.5	-7.0
260.108	26.8	29.4	14.5	41.3	43.9	V	187	170	46	-4.7
499.680	18.5	23.1	21.2	39.7	44.3	V	140	200	46	-6.3
624.990	14	19.8	22.8	36.8	42.6	V	120	235	46	-9.2
Supplementary information: Frequency list measured on the Open Area Test Site is created with pre-scan results. Worst case results for all communication modes.										
Frequency band investigated:		30MHz-1GHz								
RBW:		120kHz								
Measurement distance:		3m								
Limit:		FCC Part 15.209 – 15.249 / RSS-Gen §8.9 – RSS-210 §B.10 (b)								
Final measurement detector:		Quasi-Peak								
RESULT:		PASS								
Note:		Limits used are FCC part 15.209 / RSS-Gen.								

Tabulated Results for Unwanted emissions (1GHz-10GHz)				
FREQ (MHz)	Field level dB μ V/m	Detector	Limit (dB μ V/m)	Result
Levels at least 10dB below limits		Pk	74 Pk	Pass
Levels at least 10dB below limits		Av	54 Av	Pass
RBW	1MHz (CISPR)			
Measurement distance:	3m			
Limit:	FCC Part 15.209 – 15.249 / RSS-Gen §8.9 – RSS-210 §B.10 (b)			
Final measurement detector:	Peak / CISPR Average			
RESULT:	PASS			
Notes:	Limits used are FCC part 15.209 / RSS-Gen.			

Graphical representation of Band-edge compliance (Radiated)

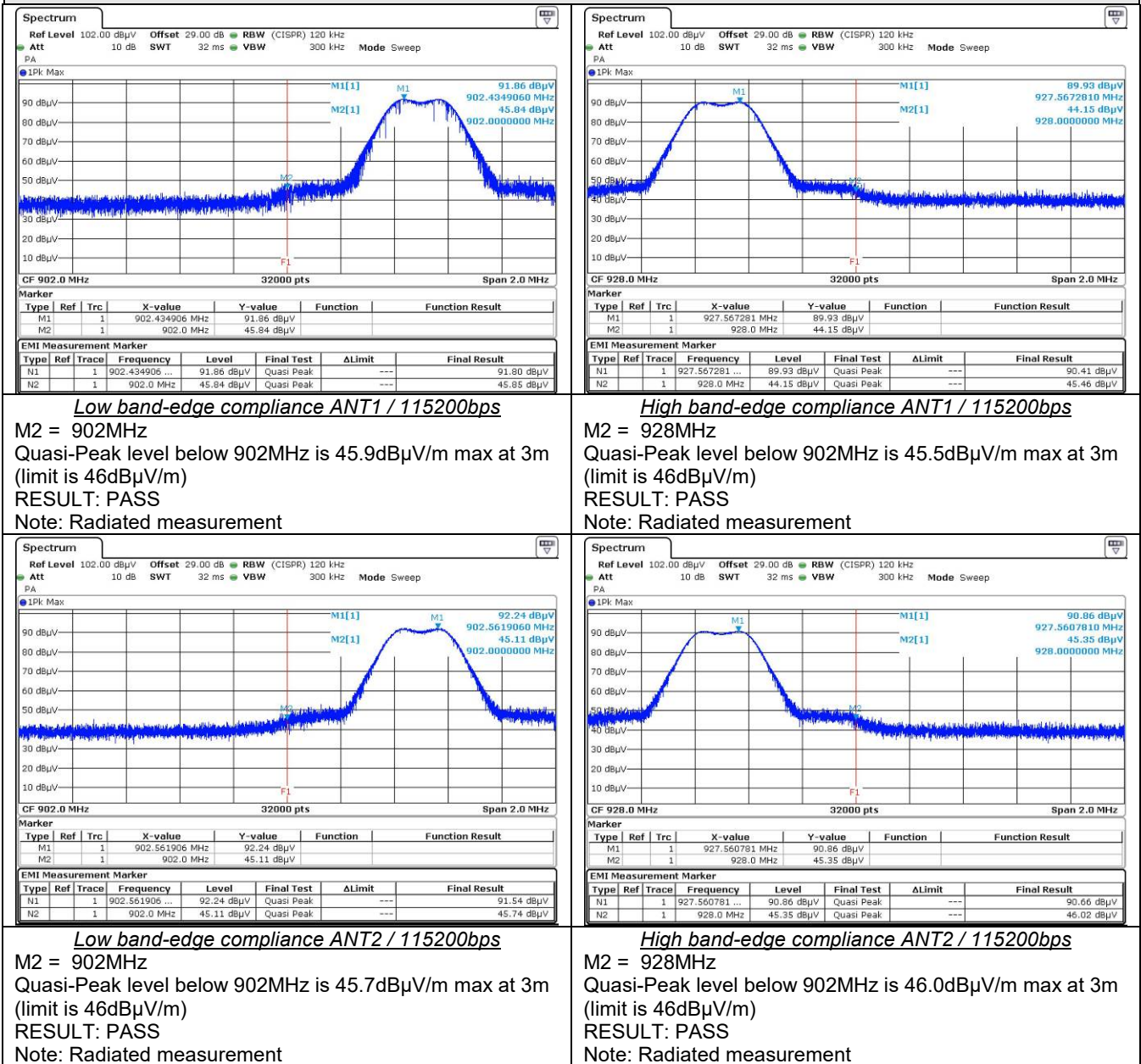

Graphical representation of Band-edge compliance (Radiated)

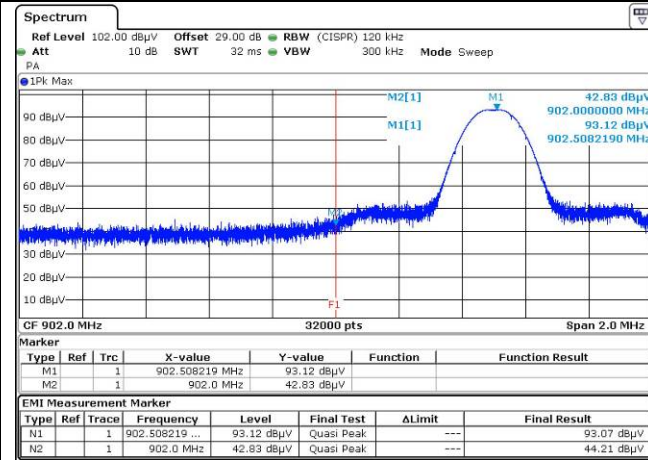

Low band-edge compliance ANT1 19200 bps

M2 = 902MHz
 Quasi-Peak level below 902MHz is 44.2dBµV/m max at 3m
 (limit is 46dBµV/m)
RESULT: PASS
 Note: Radiated measurement

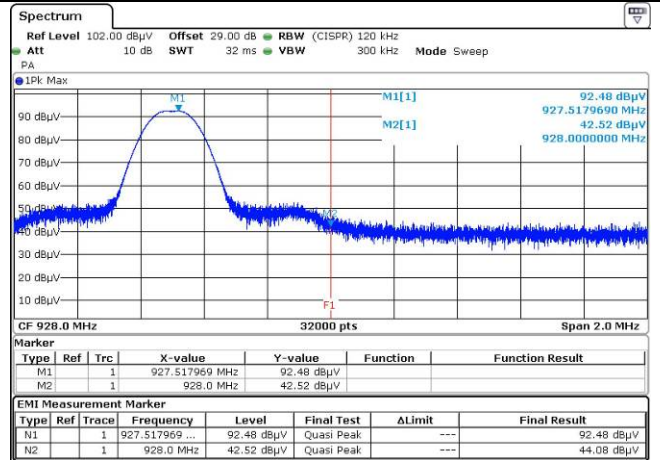

High band-edge compliance ANT1 19200 bps

M2 = 928MHz
 Quasi-Peak level below 902MHz is 44.1dBµV/m max at 3m
 (limit is 46dBµV/m)
RESULT: PASS
 Note: Radiated measurement

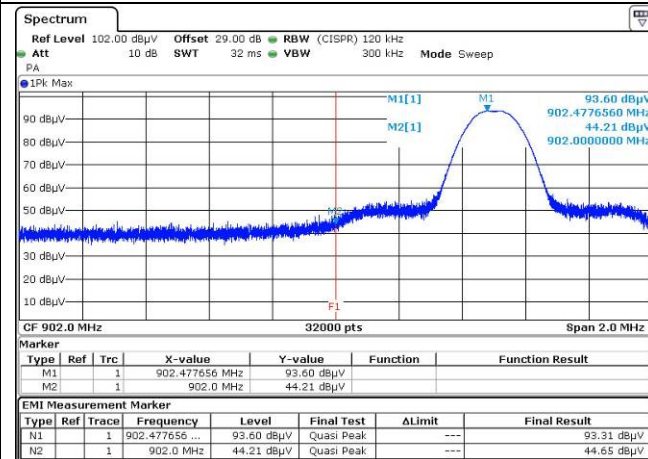

Low band-edge compliance ANT2 19200 bps

M2 = 902MHz
 Quasi-Peak level below 902MHz is 44.7dBµV/m max at 3m
 (limit is 46dBµV/m)
RESULT: PASS
 Note: Radiated measurement

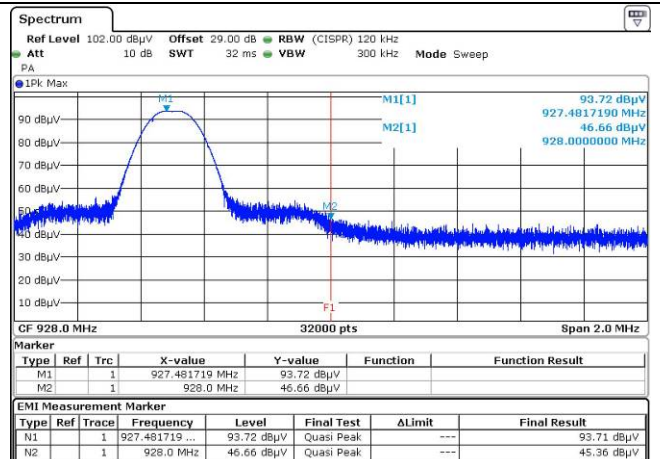

High band-edge compliance ANT2 19200 bps

M2 = 928MHz
 Quasi-Peak level below 902MHz is 45.4dBµV/m max at 3m
 (limit is 46dBµV/m)
RESULT: PASS
 Note: Radiated measurement

Graphical representation of Radiated Disturbance Measurement (Peak detection, Anechoic chamber pre-scan, 9kHz-30MHz / 3m / Parallel & Perpendicular antenna position / Transmit mode)

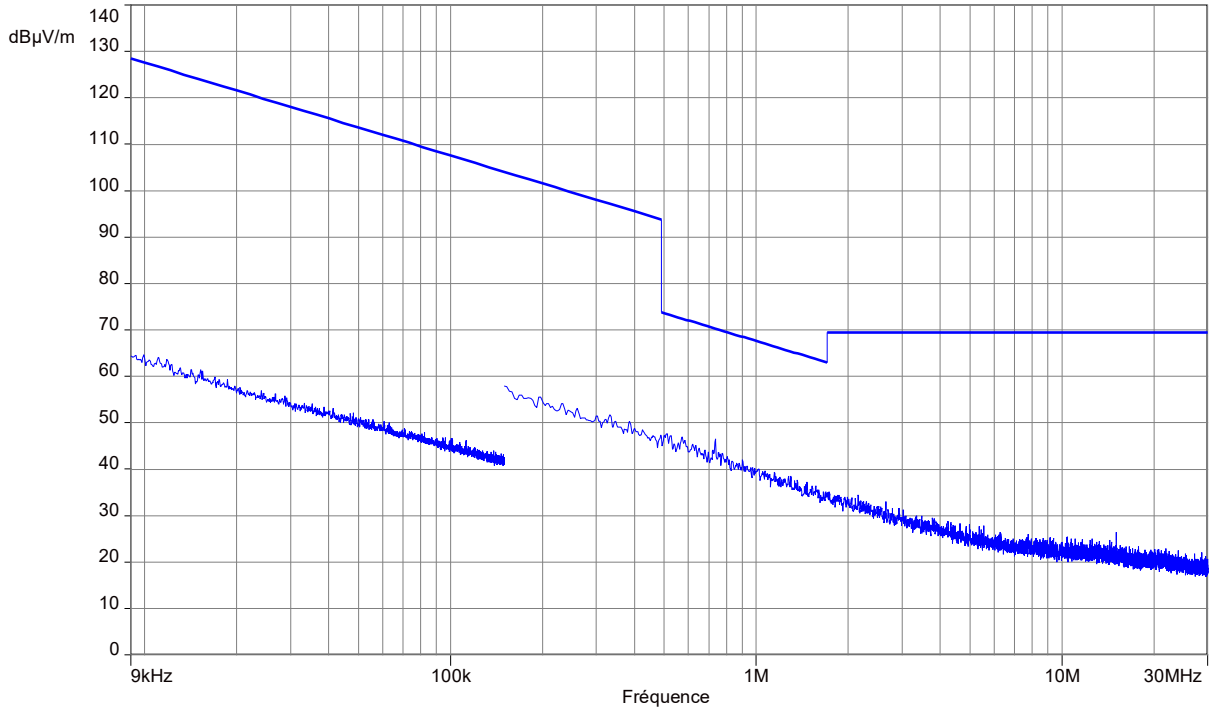

Notes: Pre-scan graph only for identification purpose.
Same result for transmit mode on all channels/antennas, all communication modes.

Frequency band investigated:	9kHz-30MHz
Unit :	dBµV/m
RBW :	200Hz (9kHz-150kHz) 9kHz (150kHz-30MHz)
Antenna polarization :	Parallel & Perpendicular to measurement axis
Measurement detector:	Peak

Graphical representation of Radiated Disturbance Measurement (Anechoic chamber pre-scan, 30MHz-10GHz / 3m)

Horizontal polarization (Mid channel/POE)

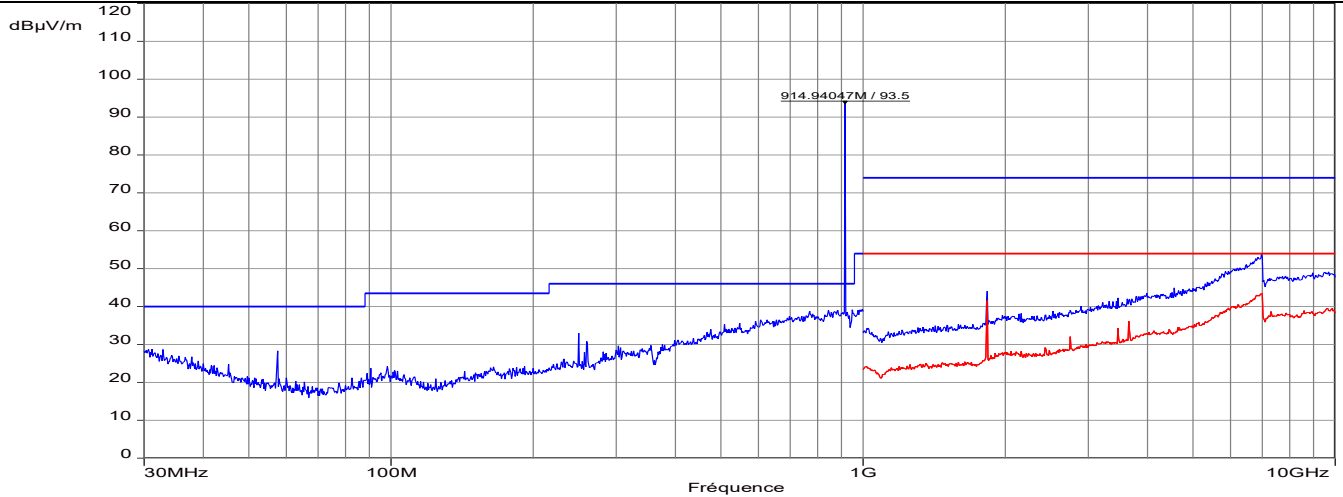

Vertical polarization (Mid channel/POE)

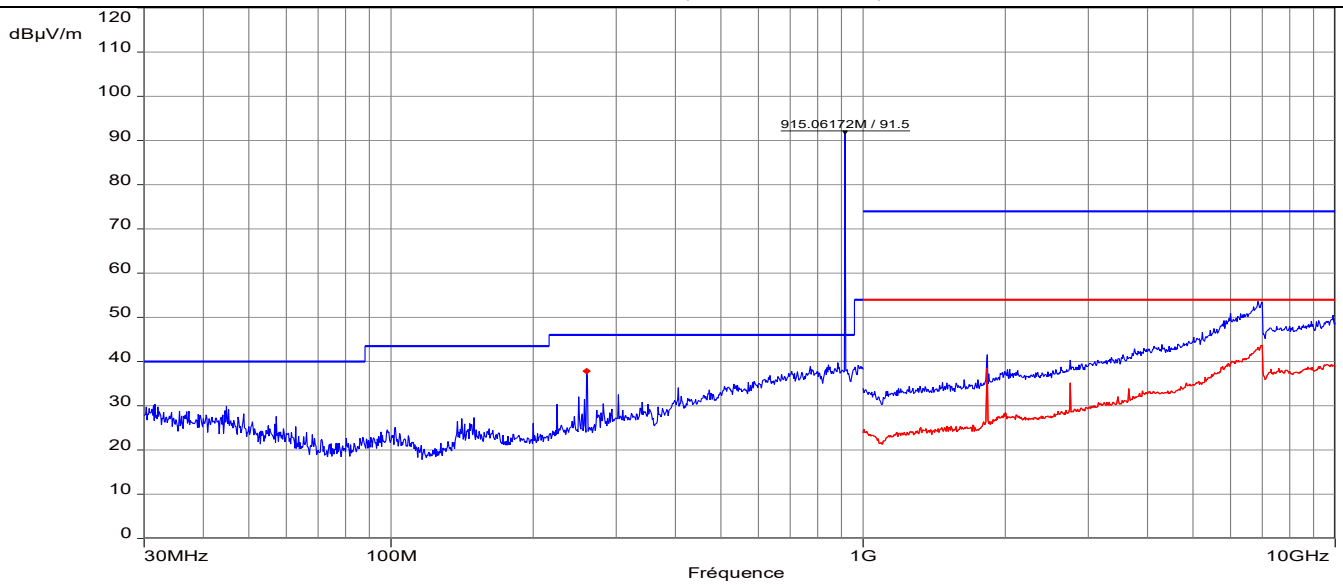

----- : Peak measure / limits

----- : Average measure / limits

Note: Pre-scan graph only for identification purpose. Same result for all channels/antennas.

Marker List :

Frequency (MHz)	Peak Level (dBµV/m)	Limit (dBµV/m)	Polarization
260.14	37.84	43.5	V

Graphical representation of Radiated Disturbance Measurement (Anechoic chamber pre-scan, 30MHz-10GHz / 3m)

Horizontal polarization (Mid channel/RS422+24V)

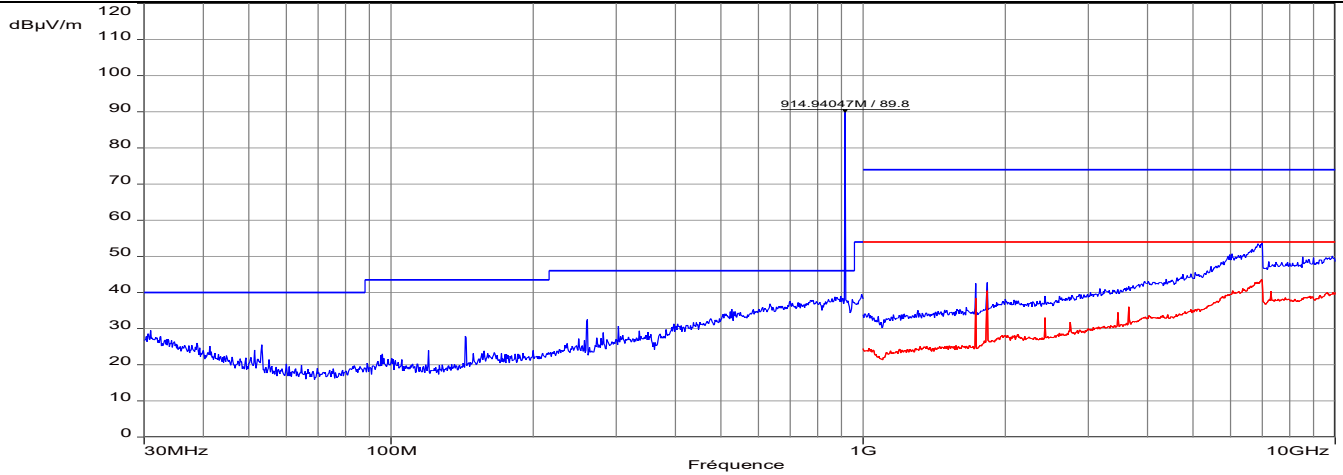

Vertical polarization (Mid channel/RS422+24V)

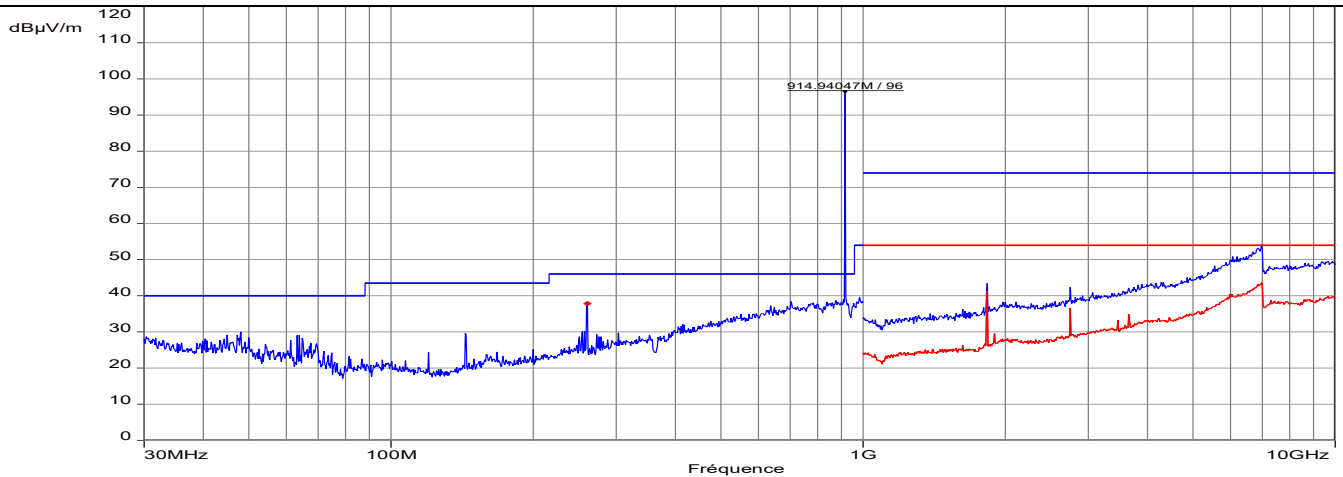

----- : Peak measure / limits

----- : Average measure / limits

Note: Pre-scan graph only for identification purpose. Same result for all channels/antennas.

Marker List :

Frequency (MHz)	Peak Level (dBµV/m)	Limit (dBµV/m)	Polarization
260.2	37.89	43.5	V

Graphical representation of Radiated Disturbance Measurement (Anechoic chamber pre-scan, 30MHz-10GHz / 3m)

Horizontal polarization (Mid channel/ETH+24V)

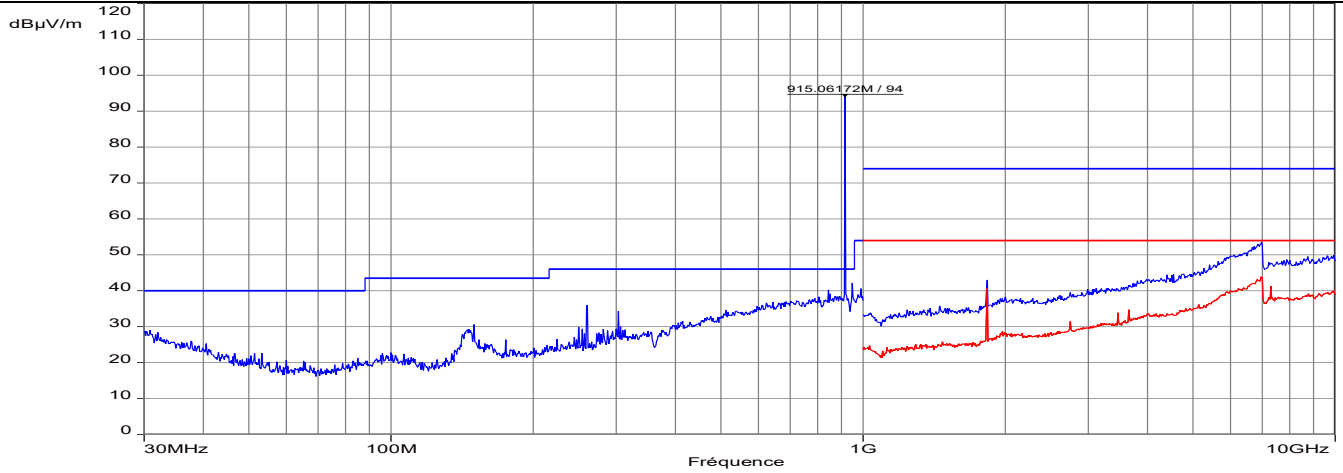

Vertical polarization (Mid channel/ETH+24V)

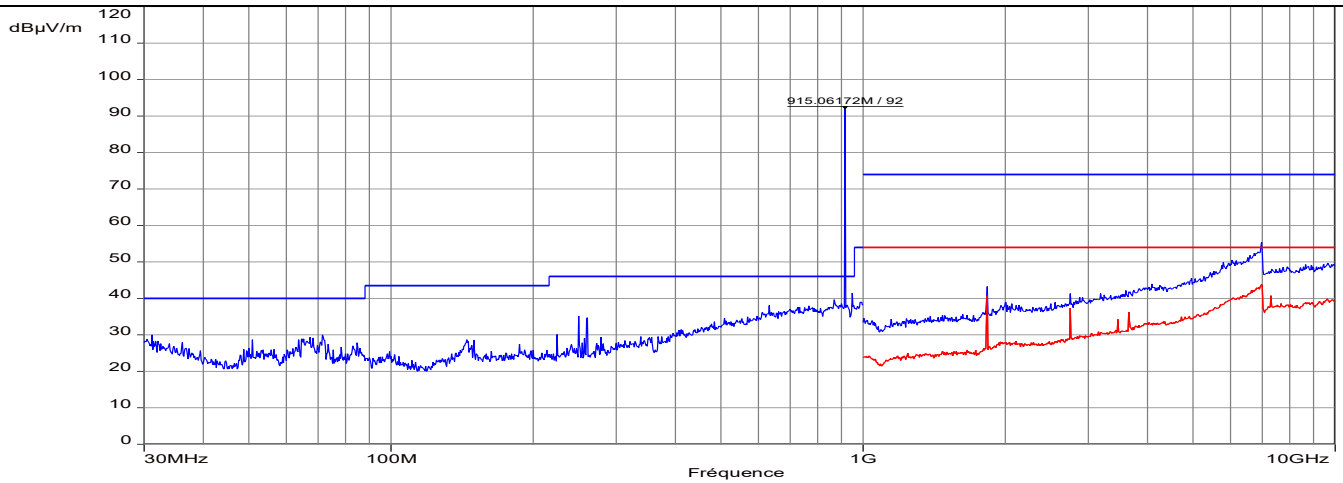

----- : Peak measure / limits

----- : Average measure / limits

Note: Pre-scan graph only for identification purpose. Same result for all channels/antennas.

Marker List :

Frequency (MHz)	Peak Level (dBµV/m)	Limit (dBµV/m)	Polarization
None			

Graphical representation of Radiated Disturbance Measurement (Anechoic chamber pre-scan, 30MHz-10GHz / 3m)

Horizontal polarization (Mid channel/USB)

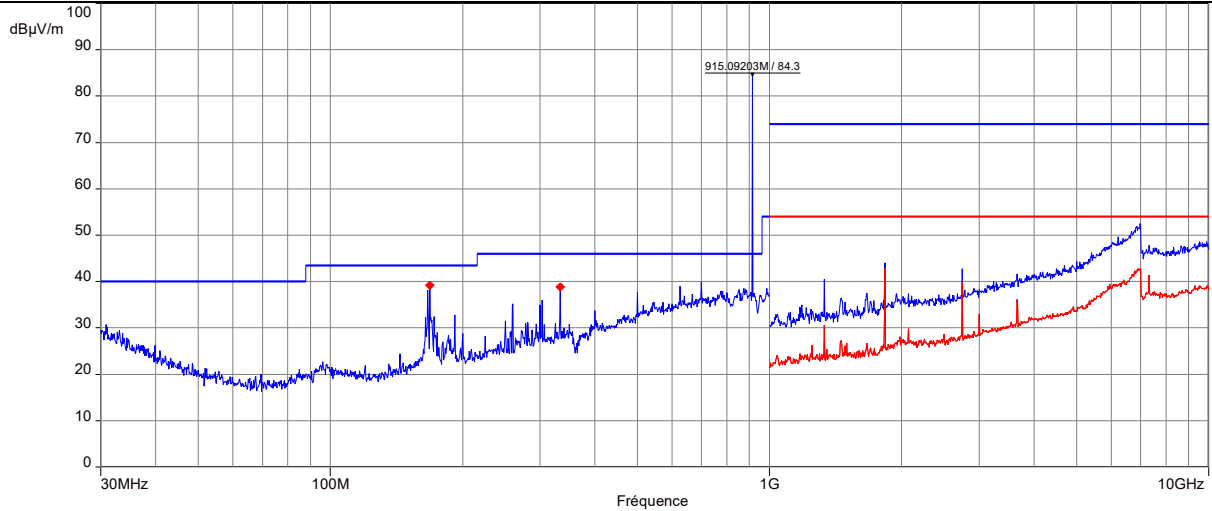

Vertical polarization (Mid channel/USB)

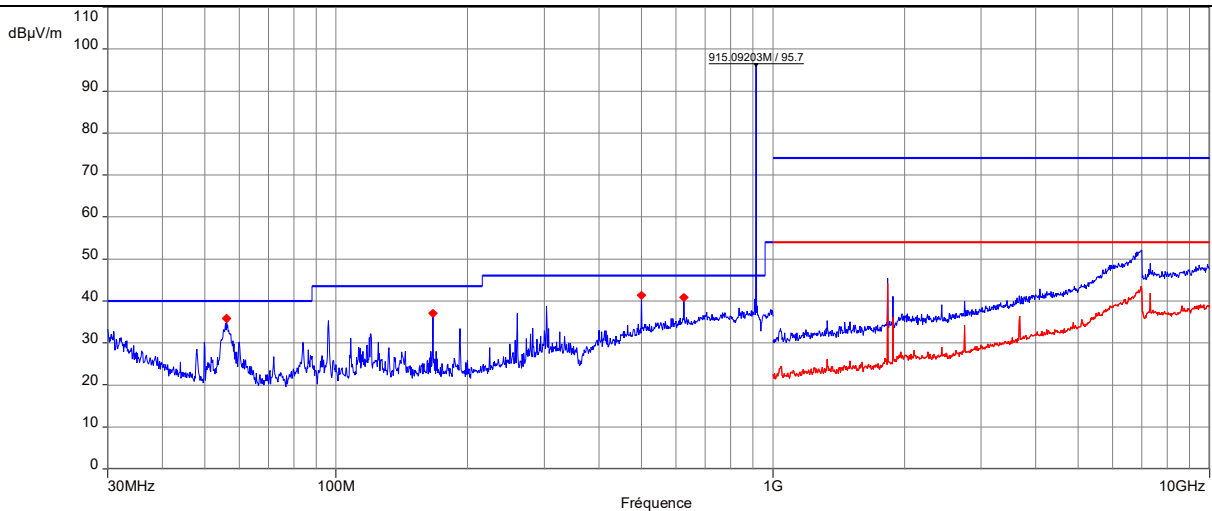

----- : Peak measure / limits

----- : Average measure / limits

Note: Pre-scan graph only for identification purpose. Same result for all channels/antennas.

Marker List :

Frequency (MHz)	Peak Level (dBµV/m)	Limit (dBµV/m)	Polarization
168.563	39.27	40	H
333.286	38.87	46	H
56.0696	35.86	40	V
166.653	37.11	43.5	V
499.98	41.33	46	V
624.992	40.92	46	V

13. Occupied bandwidth (99%)

TEST: Occupied bandwidth (99%) / RSS-GEN		Verdict
<p>Method: The setup is in an anechoic chamber. The spectrum analyzer is connected to the measuring antenna. A radiated measurement is performed. The RBW is set in the range of 1% to 5% of the occupied bandwidth, with VBW $\geq 3 \times$ RBW. The SPAN is wide enough to capture all products of the modulation process. A Peak detector is used. Measure is performed with OBW 99% function of the spectrum analyser. The tested equipment is set to transmit operation with modulation on low, mid and high channels.</p>		Pass
Laboratory Parameters:	Required prior to the test	During the test
Ambient Temperature	20 to 30 °C	25°C \pm 2
Relative Humidity	30 to 70 %	45% \pm 5
Supplementary information: Test location: SMEE Test date: May 20 th , 2020		

Test Equipment Used					
Description	Manufacturer	Model	Identifier	Cal. Date	Cal. Due
Horn antenna	ETS-LINDGREN	3115	ANT-141-013	2018/10	2021/10
RF cable	Pasternack RF	PE302-120	CAB-131-024	2019/4	2020/4
RF cable	HUBER+SUHNER	SF104	CAB-141-030	2019/4	2020/4
Anechoic chamber	COMTEST	214263	CAG-141-001	2017/6	2020/6
Measuring Rec	Rohde&Schwarz	ESRP	REC-151-002	2019/9	2021/9

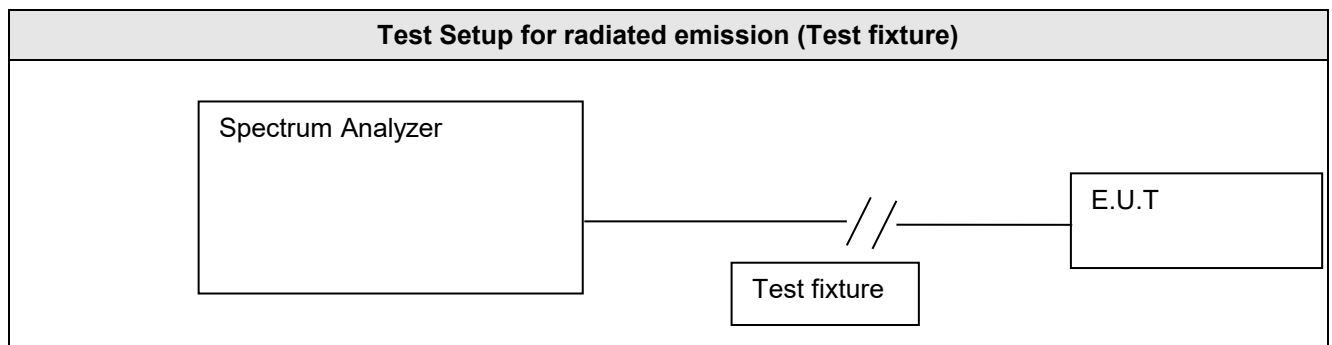

Tabulated Results for Occupied Bandwidth

Frequency (MHz)	99% Occupied Bandwidth (kHz)	
Data rates	115200 bps	19200 bps
902.5	226.126	53.618
915.0	225.059	53.678
927.5	226.759	53.525

Graphical representation of Occupied Bandwidth



Low Channel

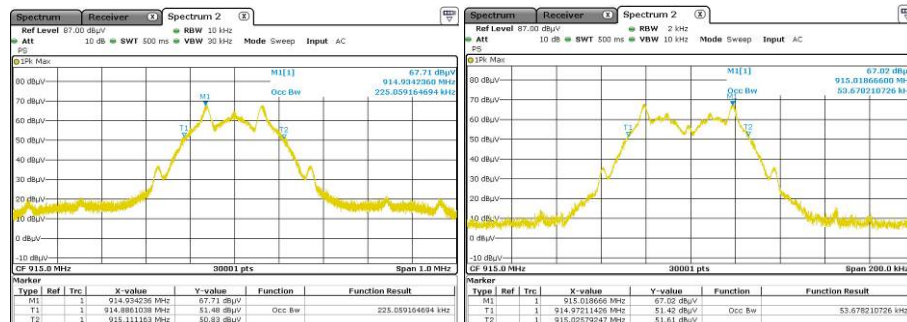

Mid Channel

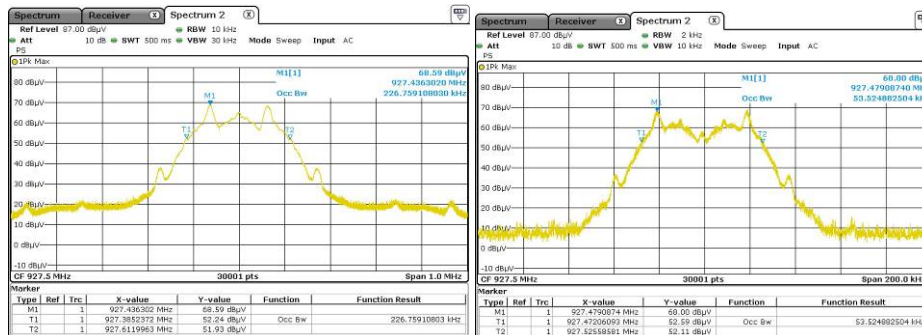

High Channel

Frequency band investigated:	902 to 928MHz
RBW / VBW :	10kHz / 30kHz and 2kHz / 10kHz
Measurement detector:	Peak / Max hold