



198 Kezhu Road, Sciencetech Park, Guangzhou Economic & Technology
Development District, Guangzhou, Guangdong, China 510663
Telephone: +86 (0) 20 82155555
Fax: +86 (0) 20 82075059
Email: sgs_internet_operations@sgs.com
FEDERAL COMMUNICATIONS COMMISSION
Registration number: 282399

Report No.: GLEMO081203740RFT
Page: 1 of 23
FCC ID: ONFT70TX-08ERB

TEST REPORT

Application No. : GLEMO081203740RF
Applicant: Tele Radio AB
FCC ID: ONFT70TX-08ERB
Fundamental Frequency : 433.075-434.650 MHz
Equipment Under Test (EUT):
EUT Name: Transmitter T70TX
Model No.: T70TX-08ERB
Serial No.: No supply by client
Standards: FCC PART 15, SUBPART C: 2008
Section 15.231(a)
Date of Receipt: April 13, 2009
Date of Test: April 13, 2009 to April 16, 2009
Date of Issue: April 16, 2009

Test Result :	PASS *
----------------------	---------------

* In the configuration tested, the EUT detailed in this report complied with the standards specified above. Please refer to section 2 of this report for further details..

Authorized Signature:

Stephen Guo
Lab Manager

The manufacturer should ensure that all products in series production are in conformity with the product sample detailed in this report. If the product in this report is used in any configuration other than that detailed in the report, the manufacturer must ensure the new system complies with all relevant standards.

The report must not be used by the client to claim product certification, approval, or endorsement by NVLAP, NIST, or any agency of the federal government. All test results in this report can be traceable to National or International Standards.

This document is issued by the Company under its General Conditions of Service printed overleaf or available on request and accessible at http://www.sgs.com/terms_and_conditions.htm. Attention is drawn to the limitation of liability, indemnification and jurisdiction issues defined therein. Any holder of this document is advised that information contained hereon reflects the Company's findings at the time of its intervention only and within the limits of Client's instructions, if any. The Company's sole responsibility is to its Client and this document does not exonerate parties to a transaction from exercising all their rights and obligations under the transaction documents. Any unauthorized alteration, forgery or falsification of the content or appearance of this document is unlawful and offenders may be prosecuted to the fullest extent of the law." Unless otherwise stated the results shown in this test report refer only to the sample(s) tested. This document cannot be reproduced except in full, without prior approval of the Company.



2 Version

Version No.	Date	Description
00	April 16, 2009	New application

Prepared By: ***Kobe Jian & Angel Liu*** ***Date*** ***2009-4-17***

Project Engineer

Check By: ***Gavin Wu*** ***Date*** ***2009-4-20***

Reviewer

This document is issued by the Company under its General Conditions of Service printed overleaf or available on request and accessible at http://www.sgs.com/terms_and_conditions.htm. Attention is drawn to the limitation of liability, indemnification and jurisdiction issues defined therein. Any holder of this document is advised that information contained hereon reflects the Company's findings at the time of its intervention only and within the limits of Client's instructions, if any. The Company's sole responsibility is to its Client and this document does not exonerate parties to a transaction from exercising all their rights and obligations under the transaction documents. Any unauthorized alteration, forgery or falsification of the content or appearance of this document is unlawful and offenders may be prosecuted to the fullest extent of the law." Unless otherwise stated the results shown in this test report refer only to the sample(s) tested. This document cannot be reproduced except in full, without prior approval of the Company.



3 Test Summary

The customer requested FCC tests for a 433.075-434.650 MHz transmitter.			
Test	Test Requirement	Standard Paragraph	Result
Radiated Emission (30 MHz to 5000MHz)	FCC PART 15 :2008	Section 15.231(a)	PASS
Occupied Bandwidth	FCC PART 15 :2008	Section 15.231(a)	PASS
Dwell Time	FCC PART 15 :2008	Section 15.231(a)	PASS
Label Requirement	FCC PART 15 :2008	Section 15.19	N/A



4 Contents

	Page
1 COVER PAGE.....	1
2 VERSION.....	2
3 TEST SUMMARY	3
4 CONTENTS	4
5 GENERAL INFORMATION.....	5
5.1 CLIENT INFORMATION.....	5
5.2 DETAILS OF E.U.T.	5
5.3 DESCRIPTION OF SUPPORT UNITS	5
5.4 STANDARDS APPLICABLE FOR TESTING.....	5
5.5 TEST LOCATION	5
5.6 OTHER INFORMATION REQUESTED BY THE CUSTOMER	5
5.7 TEST FACILITY	6
6 EQUIPMENTS USED DURING TEST	7
7 TEST RESULTS.....	8
7.1 E.U.T. TEST CONDITIONS	8
7.2 RADIATED EMISSIONS	10
7.3 OCCUPIED BANDWIDTH	18
7.4 DWELL TIME:	20
7.5 LABEL REQUIREMENT.....	23



5 General Information

5.1 Client Information

Applicant Name: Tele Radio AB

Applicant Address: Datavägen 21, SE-436 32 Askim, Sweden.

5.2 Details of E.U.T.

Name: Transmitter T70TX

Model No.: T70TX-08ERB

Function: 64 different frequencies, 433.075-434.650 MHz, channel space is 25 kHz

Power Supply: DC 4.5 V (3 x 1.5 V 'AA' batteries)

Power Cord: N/A

5.3 Description of Support Units

The EUT was tested as an independent unit.

5.4 Standards Applicable for Testing

The customer requested FCC tests for the EUT.

The standard used was FCC PART 15, SUBPART C: 2008 ,Section 15.231

5.5 Test Location

All tests were performed at:

SGS-CSTC Standards Technical Services Co., Ltd., Guangzhou EMC Laboratory,
198 Kezhu Road, Sciencetech Park, Guangzhou Economic & Technology Development District,
Guangzhou, China 510663

Tel: +86 20 82155555 Fax: +86 20 82075059

No tests were sub-contracted.

5.6 Other Information Requested by the Customer

None.



SGS-CSTC Standards Technical Services Ltd.

Report No.: GLEMO081203740RFT

Page: 6 of 23

FCC ID: ONFT70TX-08ERB

5.7 Test Facility

The test facility is recognized, certified, or accredited by the following organizations:

- **NVLAP – Lab Code: 200611-0**

SGS-CSTC Standards Technical Services Co., Ltd., Guangzhou EMC Laboratory is recognized under the National Voluntary Laboratory Accreditation Program (NVLAP/NIST). NVLAP Code: 200611-0.

- **FCC – Registration No.: 282399**

SGS-CSTC Standards Technical Services Co., Ltd., EMC Laboratory has been registered and fully described in a report filed with the (FCC) Federal Communications Commission. The acceptance letter from the FCC is maintained in our files. Registration 282399, May 31, 2002.



6 Equipments Used during Test

RE in Chamber						
No:	Test Equipment	Manufacturer	Model No.	Serial No.	Cal. Date (dd-mm-yy)	Cal.Due date (dd-mm-yy)
EMC0525	Compact Semi-Anechoic Chamber	ChangZhou ZhongYu	N/A	N/A	N/A	N/A
EMC0522	EMI Test Receiver	Rohde & Schwarz	ESIB26	100249	28-01-2009	28-01-2010
EMC0056	EMI Test Receiver	Rohde & Schwarz	ESCI	10036	14-07-2008	14-07-2009
N/A	EMI Test Software	Audix	E3	N/A	N/A	N/A
EMC0514	Coaxial cable	SGS	N/A	N/A	04-12-2008	04-12-2009
EMC0524	Bi-log Type Antenna	Schaffner -Chase	CBL6112B	2966	12-08-2008	12-08-2009
EMC0519	Bilog Type Antenna	Schaffner -Chase	CBL6143	5070	12-08-2008	12-08-2009
EMC0517	Horn Antenna	Rohde & Schwarz	HF906	100095	12-08-2008	12-08-2009
EMC0040	Spectrum Analyzer	Rohde & Schwarz	FSP30	100324	05-12-2008	05-12-2009
EMC0520	0.1-1300 MHz Pre-Amplifier	HP	8447D OPT 010	2944A06252	11-03-2009	11-03-2010
EMC0521	1-26.5 GHz Pre-Amplifier	Agilent	8449B	3008A01649	11-03-2009	11-03-2010
EMC0075	310N Amplifier	Sonama	310N	272683	10-09-2008	10-09-2009
EMC0523	Active Loop Antenna	EMCO	6502	00042963	09-08-2008	09-08-2010
EMC0530	10m Semi- Anechoic Chamber	ETS	N/A	N/A	10-08-2008	10-08-2009

General used equipment						
No:	Test Equipment	Manufacturer	Model No.	Serial No.	Cal. Date (dd-mm-yy)	Cal.Due date (dd-mm-yy)
EMC0006	DMM	Fluke	73	70681569	23-12-2008	23-12-2009
EMC0007	DMM	Fluke	73	70671122	23-12-2008	23-12-2009

7 Test Results

7.1 E.U.T. test conditions

Power supply: DC 4.5 V (new battery)

Requirements: **15.31(e)** :For intentional radiators, measurements of the variation of the input power or the radiated signal level of the fundamental frequency component of the emission, as appropriate, shall be performed with the supply voltage varied between 85% and 115% of the nominal rated supply voltage. For battery operated equipment, the equipment tests shall be performed using a new battery.

Type of antenna: Integral

Operating Environment:
 Temperature: 22-25.0 °C
 Humidity: 48-55% RH
 Atmospheric Pressure: 1001-1010 mbar

Test frequencies: According to the 15.31(m) Measurements on intentional radiators or receivers, other than TV broadcast receivers, shall be performed and, if required, reported for each band in which the device can be operated with the device operating at the number of frequencies in each band specified in the following table:

Frequency range over which device operates	Number of frequencies	Location in the range of operation
1 MHz or less	1	Middle
1 to 10 MHz	2	1 near top and 1 near bottom
More than 10 MHz	3	1 near top, 1 near middle and 1 near bottom



SGS-CSTC Standards Technical Services Ltd.

Report No.: GLEMO081203740RFT

Page: 9 of 23

FCC ID: ONFT70TX-08ERB

EUT channels and frequencies list:

Channel No.	Freq.Band 1 (MHz)	Freq.Band 2 (MHz)	Freq.Band 3 (MHz)	Freq.Band 4 (MHz)
1	433.075	433.100	433.125	433.150
2	433.175	433.200	433.225	433.250
3	433.275	433.300	433.325	433.350
4	433.375	433.400	433.425	433.450
5	433.475	433.500	433.525	433.550
6	433.575	433.600	433.625	433.650
7	433.675	433.700	433.725	433.750
8	433.775	433.800	433.825	433.850
9	433.875	433.900	433.925	433.950
10	433.975	434.000	434.025	434.050
11	434.075	434.100	434.125	434.150
12	434.175	434.200	434.225	434.250
13	434.275	434.300	434.325	434.350
14	434.375	434.400	434.425	434.450
15	434.475	434.500	434.525	434.550
16	434.575	434.600	434.625	434.650

Since the carriers of the EUT are 433.075~434.650 MHz and the alignment range of the transmitter is 1 to 10 MHz. So full test is carried out on the lowest channel: 0 channel(433.075 MHz), and highest channel: 63 channel (434.650 MHz).

The EUT could not produce an unmodulated carrier. Its channel spacing is 25 kHz.



7.2 Radiated Emissions

Test Requirement: FCC Part15 C Section 15.231(b)
Test Method: ANSI C63.4 section 8 & 13
Test Date: April 14, 2009
Measurement Distance: 3 m (Semi-Anechoic Chamber)
Test Status: Test in fixing operating frequency at lowest, highest channel.
Requirements: the field strength of emissions from intentional radiators operated under this Section shall not exceed the following:

Table with 3 columns: Fundamental Frequency (MHz), Field Strength of Fundamental (dBµV/m @ 3 m), and Field Strength of Harmonics and Spurious Emissions (dBµV/m @ 3 m). Rows include frequency ranges from 40.66 to 40.70 MHz to Above 470 MHz.

Detector: Peak for pre-scan
Peak and Average:
30-1000 MHz:120 kHz resolution bandwidth
1 GHz-5 GHz: 1 MHz resolution bandwidth

** linear interpolations

[Where F is the frequency in MHz, the formulas for calculating the maximum permitted fundamental field strengths are as follows: for the band 130-174 MHz, uV/m at 3 meters = 56.81818(F) - 6136.3636; for the band 260-470 MHz, uV/m at 3 meters = 41.6667(F) - 7083.3333. The maximum permitted unwanted emission level is 20 dB below the maximum permitted fundamental level.]

The fundamental frequency of the EUT is 433.075-434.650 MHz

The limit for average field strength dBuV/m for the fundamental emission= 80.8 dBµV/m

No fundamental is allowed in the restricted bands.

The limit for average field strength dBuV/m for the spurious emission=60.8 dBuV/m.Spurious in the restricted bands must be less than 60.8 dBuV/m or 15.209



And according 15.35(a)

15.35(a) On any frequency or frequencies below or equal to 1000 MHz, the limits shown are based on measuring equipment employing a CISPR quasi-peak detector function and related measurement bandwidths, unless otherwise specified.

Note: For pulse modulated devices with a pulse-repetition frequency of 20 Hz or less and for which CISPR quasi-peak measurements are specified, compliance with the regulations shall be demonstrated using measuring equipment employing a peak detector function, properly adjusted for such factors as pulse desensitization, using the same measurement bandwidths that are indicated for CISPR quasi-peak measurements.

According to 15.35 (b) Unless otherwise specified, on any frequency or frequencies above 1000 MHz, the radiated emission limits are based on the use of measurement instrumentation employing an average detector function. Unless otherwise specified, measurements above 1000 MHz shall be performed using a minimum resolution bandwidth of 1 MHz.

The average correction factor is computed by analyzing the on time in 100 msec over one complete pulse train. Analysis of the remote transmitter on time in one complete pulse train, therefore the average value of fundamental frequency is: Average = Peak value + 20log (Duty cycle), where the duty factor is calculated from following formula:

20log (Duty cycle) = 20log(T_pulse (25.057)/46.092ms) =20log(25.057/46.092)=-5.3dB

Where T_pulse =15*0.802+1*4.209+1*2.405+1*3.006+1*1.403+2*1.002 =25.057ms

Please refer to below pictures for more details.

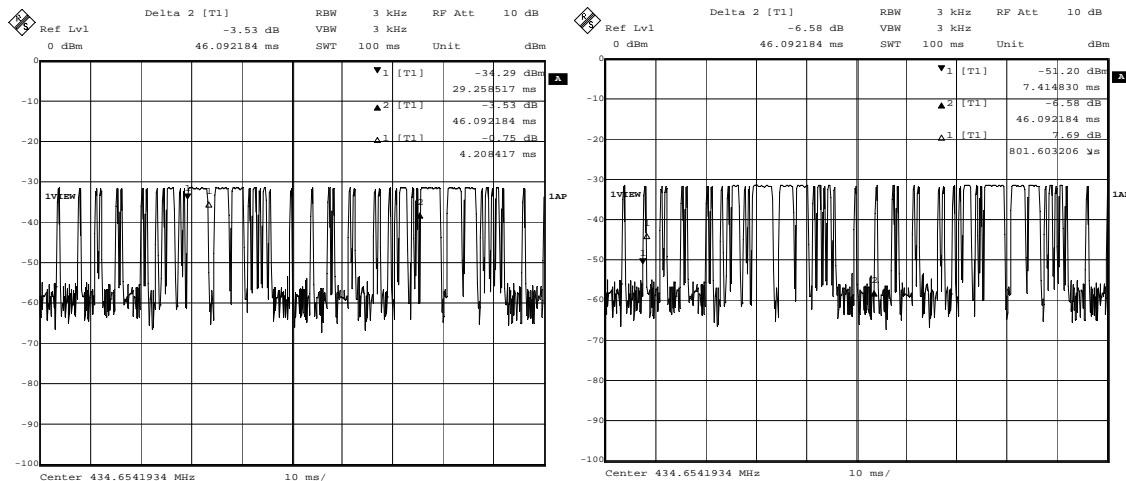

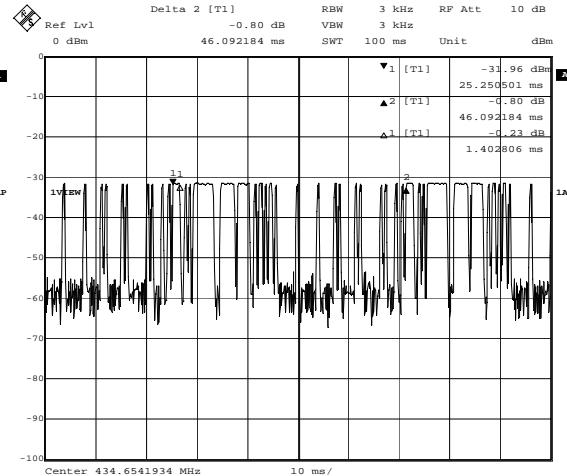
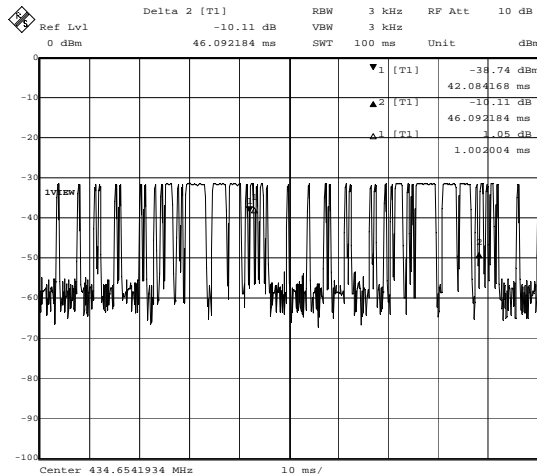
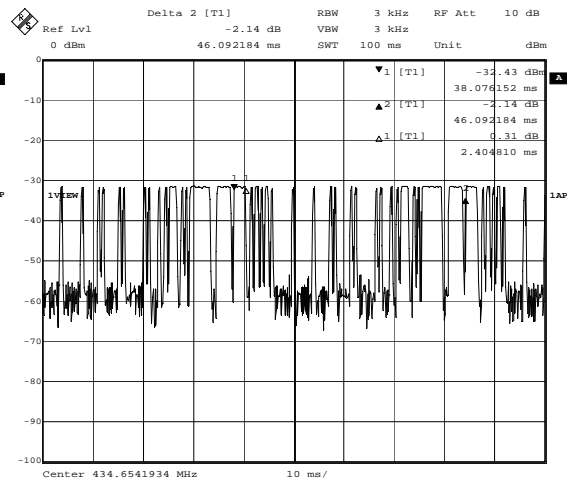
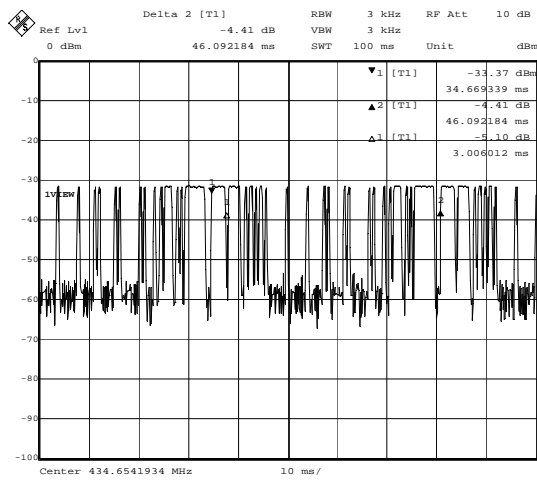

Test Procedure:

1) 30 MHz to 1 GHz emissions:

For testing performed with the bi-log type antenna, testing was performed in accordance to ANSI 63.4. The measurement is performed with the EUT rotated 360°, the antenna height scanned between 1m and 4m, and the antenna rotated to repeat the measurement for both the horizontal and vertical antenna polarizations.

2) 1 GHz to 40 GHz emissions:

For testing performed with the horn antenna, testing was performed in accordance to ANSI 63.4. The measurement is performed with the EUT rotated 360°, the antenna height scanned between 1m and 4 m, and the antenna rotated to repeat the measurement for both the horizontal and vertical antenna polarizations.

Test Configuration:

- 1) 30 MHz to 1 GHz emissions:

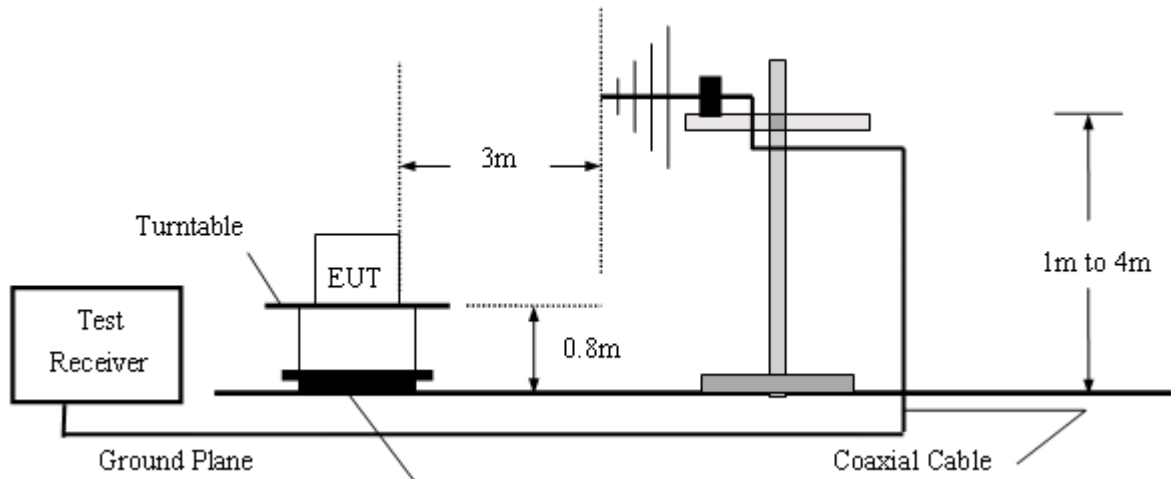

- 2) 1 GHz to 40 GHz emissions:

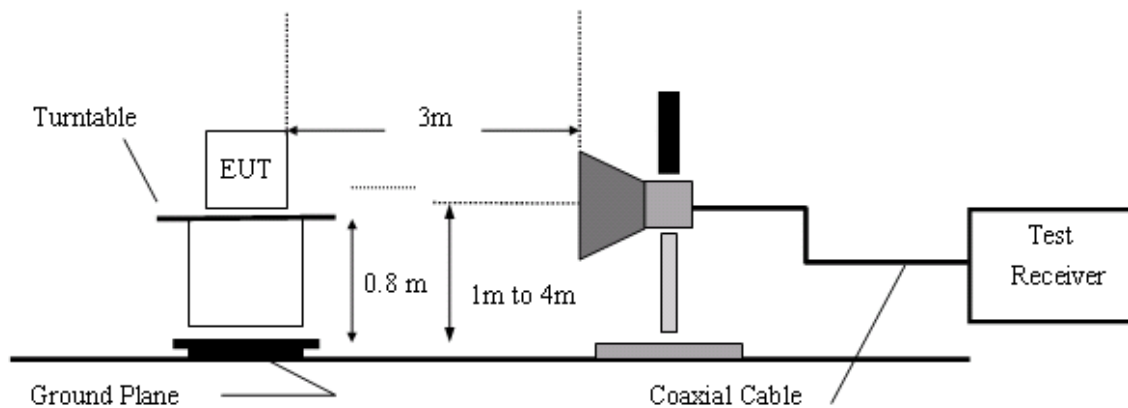

- 1) **Fundamental emission:**

Antenna polarization: Horizontal:

Frequency (MHz)	Read Level (dBuV)	Antenna Factor (dB/m)	Cable Loss (dB)	Preamplifier Factor (dB)	Level (dBuV/m)	Limit Line (dBuV/m)	Over Limit (dB)	Remark
433.075	82.76	15.77	1.80	25.20	75.13	100.8	-25.67	PEAK
433.075	-	-	-	-	69.83	80.8	-10.97	AVERAG
434.650	82.06	15.79	1.80	25.20	74.45	100.8	-26.35	PEAK
434.650	-	-	-	-	69.15	80.8	-11.65	AVERAG



Antenna polarization: Vertical

Table with 9 columns: Frequency (MHz), Read Level (dBuV), Antenna Factor (dB/m), Cable Loss (dB), Preamp Factor (dB), Level (dBuV/m), Limit Line (dBuV/m), Over Limit (dB), Remark. Rows include data for frequencies 433.075, 434.650 and remarks PEAK, AVERAG.

Y: rotate EUT by 90° vertically.

X: rotate EUT by 90° clockwise.

Z: EUT as Radiated Emission test setup photograph in section 6 of this report.

Remark: Radiated Emission test setup photograph in section 6 of this report is the worst case and reported.

2) other emissions

Test Procedure: The procedure used was ANSI Standard C63.4-2003. The receive was scanned from 30 MHz to 5000 MHz. When an emission was found, the table was rotated to produce the maximum signal strength. An initial pre-scan was performed for in peak detection mode using the receiver. The EUT was measured for both the Horizontal and Vertical polarities and performed a pre-test three orthogonal planes. The worst case emissions were reported.

An initial pre-scan was performed in the 3 m chamber using the spectrum analyzer in peak detection mode. Quasi-peak measurements were conducted based on the peak sweep graph. The EUT was measured by Bilog antenna with 2 orthogonal polarities

The field strength is calculated by adding the Antenna Factor, Cable Factor & Peramplifier. The basic equation with a sample calculation is as follows:

Final Test Level =Receiver Reading + Antenna Factor + Cable Factor -Peramplifier Factor.

The following test results were performed on the EUT.



SGS-CSTC Standards Technical Services Ltd.

Report No.: GLEMO081203740RFT

Page: 15 of 23

FCC ID: ONFT70TX-08ERB

Test the EUT in transmitting mode.

Lowest channel:

Horizontal.

Frequency (MHz)	Read Level (dBuV)	Antenna Factor (dB/m)	Cable Loss (dB)	Preamp Factor (dB)	Level (dBuV/m)	Limit Line (dBuV/m)	Over Limit (dB)	Remark
30.00	27.41	22.60	0.50	24.60	25.91	40.00	-14.09	QP
112.45	29.22	12.15	0.90	24.50	17.77	43.50	-25.73	QP
244.37	31.28	12.15	1.40	24.10	20.73	46.00	-25.27	QP
330.70	31.59	14.02	1.60	24.31	22.90	46.00	-23.10	QP
624.70	31.15	18.58	2.30	25.40	26.63	46.00	-19.37	QP
866.15	31.81	20.26	2.60	25.04	29.63	80.80	-51.17	Peak
866.15	-	-	-	-	24.33	60.80	-36.47	Average
1732.00	52.22	26.44	3.70	37.47	44.90	74.00	-29.11	Peak
1732.00	48.12	26.44	3.70	37.47	40.80	54.00	-13.20	Average
2408.00	47.96	28.60	4.30	36.97	43.89	74.00	-30.11	Peak
2408.00	26.58	28.60	4.30	36.97	22.51	54.00	-31.49	Average
3868.00	46.12	32.05	6.60	36.30	48.46	74.00	-25.54	Peak
3868.00	24.36	32.05	6.60	36.30	26.71	54.00	-27.29	Average
4752.00	46.51	33.14	6.20	36.40	49.45	74.00	-24.55	Peak
4752.00	23.45	33.14	6.20	36.40	26.39	54.00	-27.61	Average

Vertical.

Frequency (MHz)	Read Level (dBuV)	Antenna Factor (dB/m)	Cable Loss (dB)	Preamp Factor (dB)	Level (dBuV/m)	Limit Line (dBuV/m)	Over Limit (dB)	Remark
79.47	28.19	6.77	0.80	24.58	11.18	40.00	-28.82	QP
200.720	29.72	10.62	1.30	24.18	17.46	43.50	-26.04	QP
384.050	30.88	15.26	1.70	24.84	23.00	46.00	-24.43	QP
630.430	31.45	18.50	2.30	25.40	26.85	46.00	-19.15	QP
734.220	31.35	19.54	2.40	25.44	27.85	46.00	-18.15	QP
866.15	37.30	20.26	2.60	25.04	35.12	80.80	-45.68	Peak
866.15	-	-	-	-	29.82	60.80	-30.98	Average
1732.00	50.64	26.44	3.70	37.47	43.31	74.00	-30.69	Peak
1732.00	47.06	26.44	3.70	37.47	39.73	54.00	-14.27	Average
2680.00	47.43	29.33	4.63	37.00	44.40	74.00	-29.60	Average
2680.00	25.28	29.33	4.63	37.00	22.24	54.00	-31.76	Peak
4040.00	45.60	32.36	5.90	36.30	47.55	74.00	-26.45	Peak
4040.00	23.96	32.36	5.90	36.30	25.92	54.00	-28.08	Average
4812.00	45.37	33.19	6.20	36.30	48.46	74.00	-25.54	Peak
4812.00	23.61	33.19	6.20	36.30	26.71	54.00	-27.29	Average



SGS-CSTC Standards Technical Services Ltd.

Report No.: GLEMO081203740RFT

Page: 16 of 23

FCC ID: ONFT70TX-08ERB

Highest channel:

Horizontal.

Frequency (MHz)	Read Level (dBuV)	Antenna Factor (dB/m)	Cable Loss (dB)	Preamp Factor (dB)	Level (dBuV/m)	Limit Line (dBuV/m)	Over Limit (dB)	Remark
30	27.86	22.6	0.50	24.60	26.36	40.00	-13.64	QP
126.03	28.96	12.44	0.90	24.40	17.90	43.50	-25.60	QP
505.30	31.99	17.00	2.00	25.45	25.54	46.00	-20.46	QP
540.22	32.61	17.6	2.00	25.40	26.81	46.00	-19.19	QP
684.75	31.28	18.75	2.40	25.50	26.93	46.00	-19.07	QP
869.30	30.22	20.29	2.60	25.01	28.10	80.80	-52.70	Peak
869.30	-	-	-	-	22.80	60.80	-38.00	Average
1738.50	51.36	26.44	3.70	37.47	44.03	74.00	-29.97	Peak
1738.50	47.29	26.44	3.70	37.47	39.96	54.00	-14.04	Average
2240.00	47.38	28.14	4.20	37.10	42.62	74.00	-31.38	Peak
2240.00	26.87	28.14	4.20	37.10	22.11	54.00	-31.89	Average
3648.00	46.24	31.58	5.50	36.50	46.82	74.00	-27.18	Peak
3648.00	25.22	31.58	5.50	36.50	26.80	54.00	-27.20	Average
4236.00	45.99	32.56	5.73	36.33	47.95	74.00	-26.05	Peak
4236.00	26.37	32.56	5.73	36.33	28.33	54.00	-25.67	Average

Vertical.

Frequency (MHz)	Read Level (dBuV)	Antenna Factor (dB/m)	Cable Loss (dB)	Preamp Factor (dB)	Level (dBuV/m)	Limit Line (dBuV/m)	Over Limit (dB)	Remark
30.00	27.06	22.60	0.50	24.60	25.56	40.00	-14.44	QP
194.90	30.94	10.50	1.20	24.30	18.34	43.50	-25.16	QP
317.12	30.05	14.03	1.60	24.27	21.41	46.00	-24.59	QP
531.49	31.17	17.35	2.00	25.40	25.12	46.00	-20.88	QP
672.14	30.81	18.54	2.40	25.50	26.25	46.00	-19.75	QP
869.30	30.31	20.29	2.60	25.01	28.19	80.80	-52.61	Peak
869.30	-	-	-	-	22.89	60.80	-37.91	Average
1738.50	50.55	26.44	3.70	37.47	43.22	74.00	-30.78	Peak
1738.50	47.04	26.44	3.70	37.47	39.71	54.00	-14.29	Average
2012.00	47.14	27.55	4.00	37.10	41.59	74.00	-32.41	Peak
2012.00	26.42	27.55	4.00	37.10	20.87	54.00	-33.13	Average
3000.00	47.37	30.2	4.90	37.10	45.37	74.00	-28.63	Peak
3000.00	25.38	30.2	4.90	37.10	23.38	54.00	-30.62	Average
4504.00	45.44	32.86	5.90	36.30	47.90	74.00	-26.10	Peak
4504.00	25.67	32.86	5.90	36.30	28.13	54.00	-25.87	Average



SGS-CSTC Standards Technical Services Ltd.

Report No.: GLEMO081203740RFT

Page: 17 of 23

FCC ID: ONFT70TX-08ERB

Remark:

According to 15.35 (b) When average radiated emission measurements are specified in the regulations, including emission measurements below 1000 MHz, there is also a limit on the radio frequency emissions, as measured using instrumentation with a peak detector function, corresponding to 20 dB above the maximum permitted average limit for the frequency being investigated unless a different peak emission limit is otherwise specified in the rules, e.g., see Section 15.255.

Test Results: The unit does meet the FCC Part 15 C Section 15.231 requirements.



7.3 Occupied Bandwidth

Test Requirement: FCC Part 15 C Section 15.231 (C)
Test Method: ANSI C63.4 section 13 & FCC Part 2.1049
Test Date: April 13, 2009
Test Status: Test in fixing operating frequency at lowest, highest channel.
Requirements: 15.231 (c) The bandwidth of the emission shall be no wider than 0.25% of the center frequency for devices operating above 70 MHz and below 900 MHz. For devices operating above 900 MHz, the emission shall be no wider than 0.5% of the center frequency. Bandwidth is determined at the points 20 dB down from the modulated carrier.
Method of measurement: The useful radiated emission from the EUT was detected by the spectrum analyser with peak detector. Record the 20 dB bandwidth of the carrier.

Test result:

Test Channel	bandwidth	Limit
Lowest	40.08 kHz	1.08 MHz
Highest	43.60 kHz	1.09 MHz



Lowest Channel:

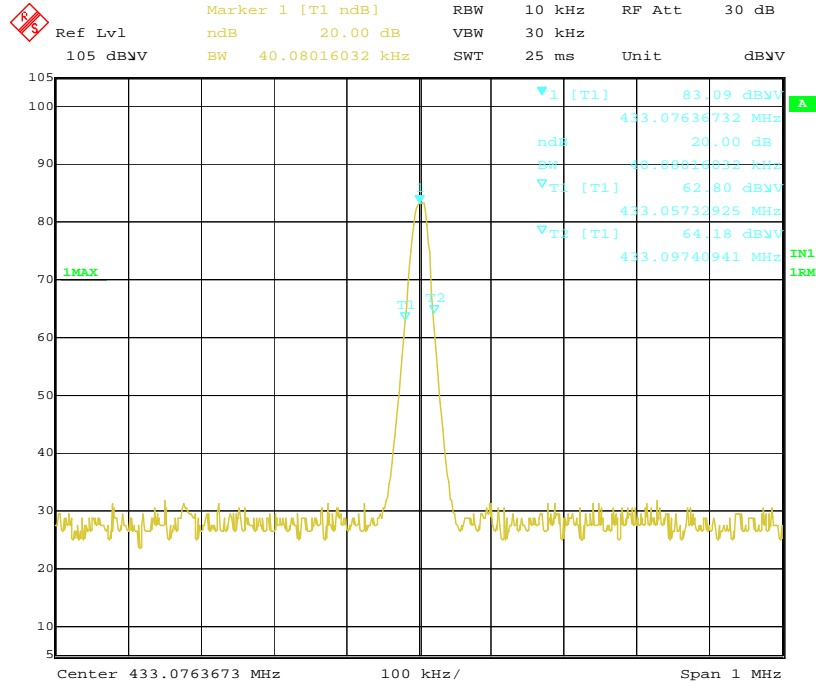

Highest Channel:

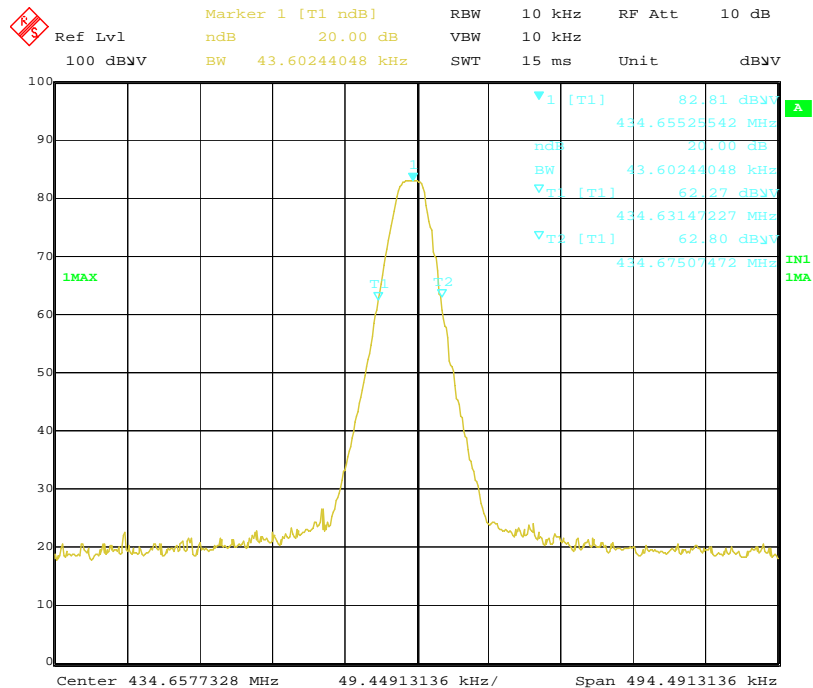

The results: The unit does meet the FCC Part 15 C Section 15.231 requirements.



7.4 Dwell Time:

Test Requirement: FCC Part 15 C Section 15.231(a)
Test Method: FCC Part15 C Section 15.231(a)
Test Date: April 16 2009
Test Status: Test in fixing operating frequency at lowest, highest channel.

Requirements:

1. Regulation 15.231 (a) The provisions of this Section are restricted to periodic operation within the band 40.66 40.70 MHz and above 70 MHz. Except as shown in paragraph (e) of this Section, the intentional radiator is restricted to the transmission of a control signal such as those used with alarm systems, door openers, remote switches, etc. Radio control of toys is not permitted. Continuous transmissions, such as voice or video, and data transmissions are not permitted. The prohibition against data transmissions does not preclude the use of recognition codes. Those codes are used to identify the sensor that is activated or to identify the particular component as being part of the system.

Result:

The EUT is a remote switch without audio or video transmitted.

The EUT meets the requirements of this section.

2. Regulation 15.231 (a1) A manually operated transmitter shall employ a switch that will automatically deactivate the transmitter within not more than 5 seconds of being released.

Result:

Carrier Frequency	Shutdown Time	Limit
Lowest	0.14s	≤5s
Highest	0.14s	

Result polt as follows:



Lowest channel:

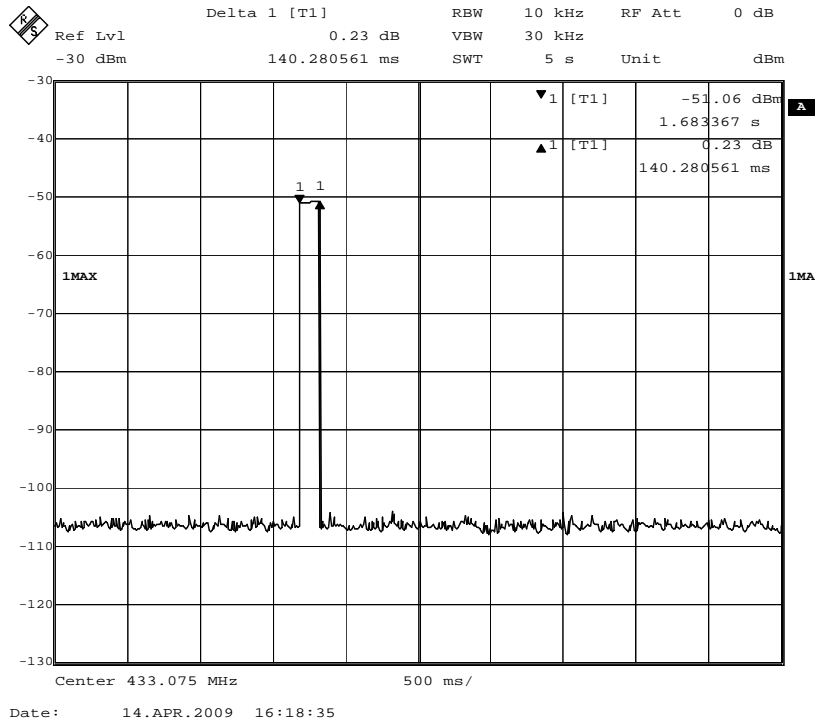

Highest channel:

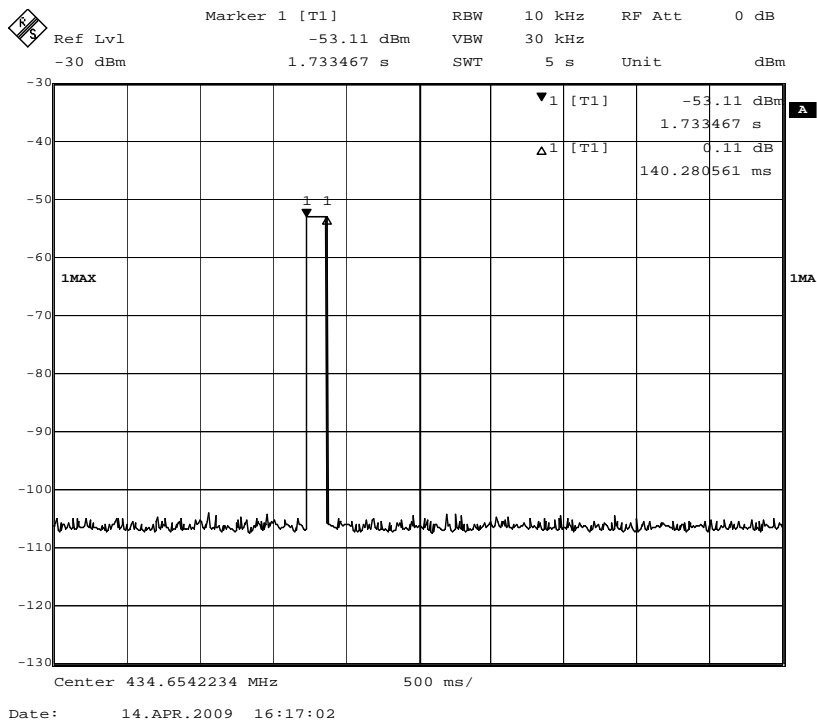

The EUT meets the requirements of this section.



SGS-CSTC Standards Technical Services Ltd.

Report No.: GLEMO081203740RFT

Page: 22 of 23

FCC ID: ONFT70TX-08ERB

3. Regulation 15.231 (a2) A transmitter activated automatically shall cease transmission within 5 seconds after activation.

Result:

The EUT does not have automatic transmission.

4. Regulation 15.231 (a3) Periodic transmissions at regular predetermined intervals are not permitted. However, polling or supervision transmissions to determine system integrity of transmitters used in security or safety applications are allowed if the periodic rate of transmission does not exceed one transmission of not more than one second duration per hour for each transmitter.

Result:

The EUT does not employ periodic transmission.

5. Regulation 15.231 (a4) Intentional radiators which are employed for radio control purposes during emergencies involving fire, security, and safety of life, when activated to signal an alarm, may operate during the pendency of the alarm condition.

Result:

This section is not applicable to the EUT.

The results: The unit does meet the FCC Part 15 C Section 15.231 requirements.



7.5 Label Requirement

Label requirement:	FCC Part 15 C Section 15.19
Base standard:	FCC Part 2, § 2.925 & § 2.926
For Certification:	
FCC identifier:	Identifier consists of the two elements. It shall be preceded by the term FCC ID in capital letters on a single line, and shall be of a type size large enough to be legible without the aid of magnification. Example: FCC ID: XXX123 Here, XXX means Grantee Code, and 123 means Equipment Product Code. Grantee Code is issued by FCC, A grantee code will have three characters consisting of Arabic numerals, capital letters, or combination thereof. while Equipment Product code be defined by the applicant. The use of "wild card" characters, such as @, (), !, &, \$ or / , in the Product Code is not allowed. Whole the FCC ID numbers are no more than 14.
Compliance statement:	The FCC identifier shall be of a type size large enough to be legible without the aid of magnification. All other devices shall bear the following statement in a conspicuous location on the device: This device complies with Part 15 of the FCC Rules. Operation is subject to the following two conditions: <ol style="list-style-type: none">1. This device may not cause harmful interference, and2. This device must accept any interference received, including interference that may cause undesired operation. But it is allowed to put it in the user manual for the device's size smaller than 8cm*10cm.
Location:	The label shall be located in a conspicuous location on the device. Label text and information should be in a size of type large enough to be readily legible, consistent with the dimensions of the equipment and the label. However, the type size for the text is not required to be larger than eight point.