

Broadband for your bicycle



**VEE**  
CYCLOCOMPUTER

**DIGITAL**

CATEYE CO., LTD. 5-2-2, MINAMI-1, HIRAKAWA-KU, TOKYO, JAPAN 06-8001  
[www.cateye.com](http://www.cateye.com) [www.cateye.co.jp](http://www.cateye.co.jp)



Broadband for your bicycle



**VEE**  
CYCLOCOMPUTER

**DIGITAL**

CATEYE CO., LTD. 5-2-2, MINAMI-1, HIRAKAWA-KU, TOKYO, JAPAN 06-8001  
[www.cateye.com](http://www.cateye.com) [www.cateye.co.jp](http://www.cateye.co.jp)



**DIGITAL**

CATEYE CO., LTD. 5-2-2, MINAMI-1, HIRAKAWA-KU, TOKYO, JAPAN 06-8001  
[www.cateye.com](http://www.cateye.com) [www.cateye.co.jp](http://www.cateye.co.jp)



Broadband for your bicycle



**VEE**  
CYCLOCOMPUTER

**DIGITAL**

CATEYE CO., LTD. 5-2-2, MINAMI-1, HIRAKAWA-KU, TOKYO, JAPAN 06-8001  
[www.cateye.com](http://www.cateye.com) [www.cateye.co.jp](http://www.cateye.co.jp)





## Introduction

Thank you for purchasing the CATEYE V2c.

The V2c is a high-performance computer for riders who wish to train extensively and analyze their data.

2.4GHz-frequency digital wireless technology, which is the same technology used for wireless LAN, is used for both the speed/cadence integrated speed sensor. This technology practically eliminates interference from external noise and cross-talk with other wireless computer users, providing you with stress-free riding.

Read this instruction manual thoroughly and understand the functions of the product before using it.

Keep it in a safe place for future reference.

### Important

- Always follow the sections that are marked with “⚠ Warning!!!”.
- No part of this manual may be reproduced or transmitted without the prior written permission of CatEye Co., Ltd.
- The contents and illustrations in this manual are subject to change without notice.
- If you have any questions or concerns about this manual, please contact CatEye at [www.cateye.com](http://www.cateye.com).

## About the manuals

### Basic installation and operation

Please go here for installation of the unit on the bicycle, preparing the computer, and the basic operation of the product.

1. How to install the unit on your bicycle ..... See page 6-8
2. Preparing the computer ..... See page 9-14
3. Basic operation of the computer ..... See page 15-16

### Measurement screen

Please go here to learn how to operate the computer functions.

- Measurement screen ..... See page 17-21

### Ride data review

Please go here to check and manage recorded data

- File view ..... See page 23-26

### Changing computer configuration

Please go here for changing and checking each menu items.

- Changing the computer configuration ..... See page 22-33

### Advanced use

- Recording lap and split time data ..... See page 19 “Lap function”
- Training with target cadence zone ..... See page 34  
“Use of the target zone”

# Contents

Introduction .....	1	Changing the computer configuration .....	22
About the manuals .....	1	File view ( <b>FILE VIEW</b> ) .....	23
Proper use of the CatEye V2c .....	3	Setting the clock/date ( <b>CLOCK.DATE</b> ) .....	27
Description of computer and its parts ....	4	Wheel selection and tire circumference ( <b>WHEEL</b> ) .....	28
Computer .....	4	Searching the sensor ID ( <b>SEnSOR-ID</b> ) .....	28
Accessories .....	4	Setting the measurement unit ( <b>UnIT</b> ) .....	30
Screen display .....	5	Total distance manual entry ( <b>ODO InPUT</b> ) .....	30
How to install the unit on your bicycle ....	6	Setting the auto-mode ( <b>AUTO MODE</b> ) .....	31
1. Attach the bracket to the stem or handlebar .....	6	Setting the countdown distance ( <b>C.D.DST→</b> ) .....	31
2. Mount the speed sensor and magnet .....	7	Setting sound ( <b>SOUNd</b> ) .....	32
3. Remove/Install the computer .....	8	Setting the target cadence zone ( <b>CDC.ZOnE</b> ) .....	33
Preparing the computer .....	9	Use of the target zone .....	34
Removing the insulation sheet .....	9	Trouble shooting .....	35
1. Formatting/Restarting operation ....	10	Trouble on display .....	35
2. Date/Clock setting .....	11	Trouble on operation .....	36
3. Tire circumference input .....	12	Replacing battery .....	37
4. Set the sensor ID .....	13	Computer .....	37
5. Selecting speed unit .....	14	Speed sensor .....	37
6. Operation test .....	14	Maintenance .....	38
Sensor signal status .....	14	Spare accessories .....	38
Basic operation of the computer .....	15	Specifications .....	39
Functions on the measurement screen .....	15	Registration .....	40
Starting/Stopping the measurement .....	16	Limited warranty .....	40
Backlight .....	16		
Resetting the measurement data ....	16		
Power-saving function .....	16		
Measurement screen .....	17		
Upper and middle display data .....	17		
Lower display data .....	18		
Pace function .....	19		
Lap function .....	19		
Countdown distance .....	20		
Target cadence zone .....	21		

## Proper use of the CatEye V2c

Observe the following instructions for safe usage.

### The meaning of icons in this manual:

 **Warning!!!** : Sections marked with these icons are critical for safe use of the device. Be sure to follow these instructions.

**Caution:** Important cautionary notes on the use and operation of the V2c.

\* Helpful tips are highlighted with asteriks.

### **Warning!!!** :

- Do not concentrate on the data while riding. Always be sure to ride safely.
- Do not leave any battery within the reach of children, and dispose of them correctly. If a battery is swallowed, consult a doctor immediately.

### **Caution:**

- Regularly check the positions of the magnets and the speed/cadence sensors and make sure that they are securely mounted. Tighten it firmly if there is any looseness.
- Avoid leaving the main unit / wireless sensor in direct sunlight for extended periods of time.
- Do not disassemble the computer, or speed sensor.
- Do not subject the computer, or speed sensor to strong impact; take care also to prevent any of them from falling.
- Do not use paint thinner or rubbing alcohol to clean the unit.
- As a nature of liquid crystal displays, sunglasses with polarized lens may block the visibility.

### **2.4GHz digital wireless system**

2.4GHz-frequency digital communication technology, which is used for wireless LAN, is adopted for both the speed/cadence integrated type speed sensor. This technology practically eliminates interference from external noise and cross-talk with other wireless computer users, and enables to store highly reliable data. However, in a very rare occasions, objects and places may generate strong electromagnetic waves and interference, which may result in incorrect measurement:

- TV, PC, radios, motors/engines, or in cars and trains.
- Railroad crossings and near railway tracks, around television transmitting stations and radar bases.
- Other wireless computers or digitally controlled lights.

# Description of computer and its parts

## Computer

### Front

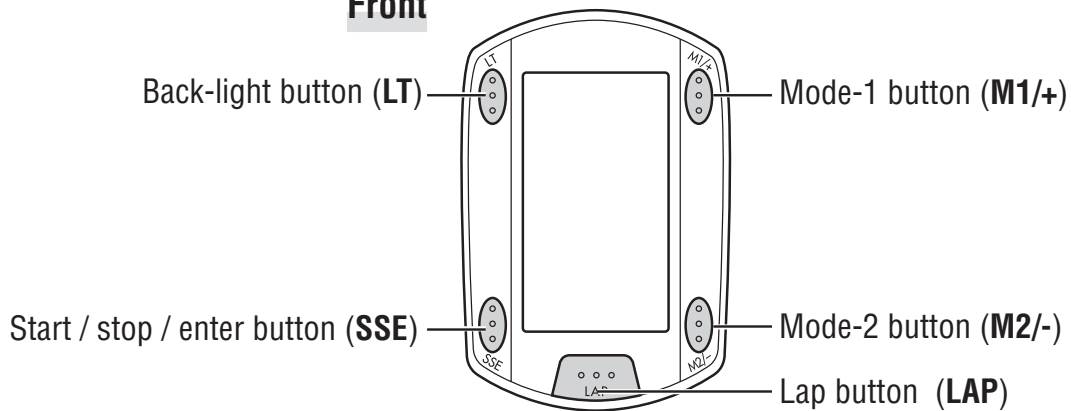

### Back

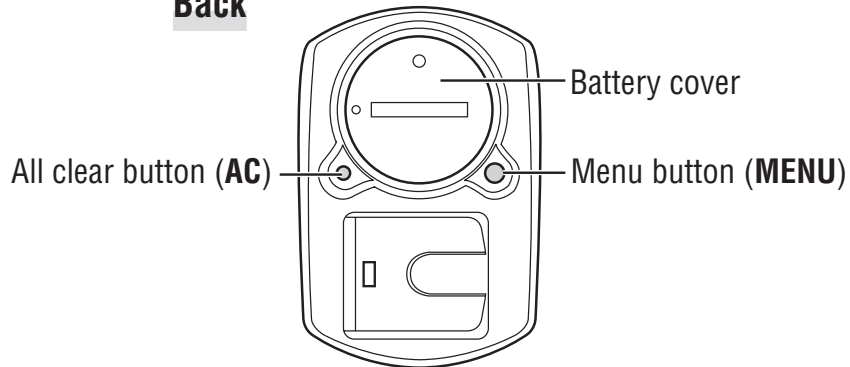

## Accessories

Bracket /  
Bracket band

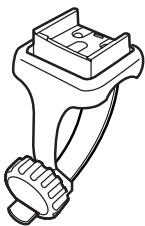

Speed sensor  
(SPEED/CADENCE)

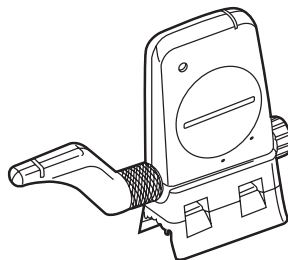

Bracket rubber pad

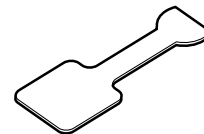

Wheel magnet



Cadence magnet



Nylon ties (x5)

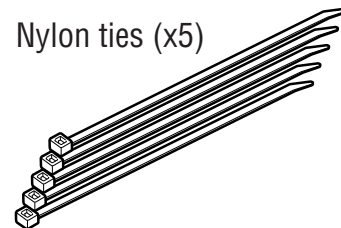



# Screen display

 : **Speed sensor signal**  
Indicate Speed sensor signal status. (page 14)

---

 : **Alarm**  
Lights up when the CDC alarm sound feature is turned on.

---

  : **Wheel selection**  
Displays the wheel currently selected.

 : **Speed pace arrow**  
The pace arrows show whether the current speed is faster (▲) or slower (▼) than the average speed.

---

**km/h mph** : **Speed unit**  
Flashes while speed measurement is in progress.

 : **Low battery indicator**  
Lights up when the remaining battery capacity for the computer is low.

 : **Average display**  
Lighting up displays that the speed, and cadence displays are average values.

 : **Maximum value display**  
Lighting up displays that the speed, and cadence displays are maximum values.

 : **Cadence pace arrow**  
The pace arrows show whether the current cadence is faster (▲) or slower (▼) than the average cadence.

**rpm** : **Cadence unit**

 : **Auto-mode**  
Lights up when the auto-mode function is on.

**LAP** : **Lap icon**  
Lights up while the lap data is displayed.

 : **Cadence sensor signal**  
Indicate Cadence sensor signal status. (page 14)

 : **Target zone**  
Lights up when the target zone is on, and flashes when it is out of the zone.

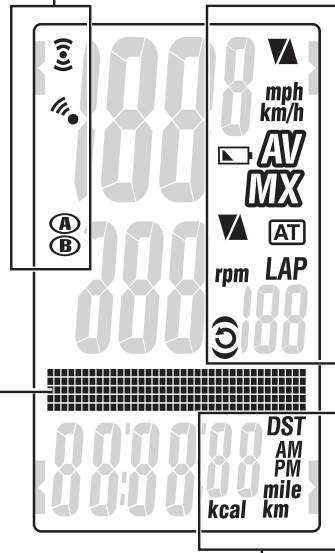

**Dot display**  
Mainly displays mode descriptions for the values displayed just below.

**Selected data icon/unit**  
Displays together with the data currently displayed in the lower display.

## Button navigation

Operative buttons at set-up of the computer, or on the menu screen, will flash.

Lights up or flashes when the **SSE** is operative.

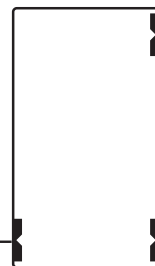

Lights up when the **M1/+** is operative.

Lights up when the **M2/-** is operative.

# How to install the unit on your bicycle

## 1. Attach the bracket to the stem or handlebar

The Flex Tight™ bracket can be attached to either the stem or the handlebar depending on how the bracket and band are configured.

### Caution:

Tighten the dial on the bracket band by hand only. Over-tightening can damage the screw threads.

### When attaching the Flex Tight™ bracket to the stem

\* Attach the bracket with its open end facing to the right.

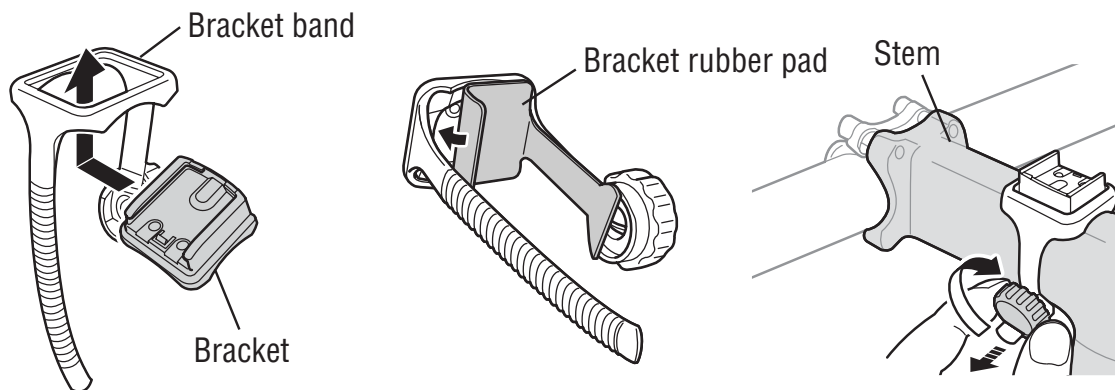

### When attaching the Flex Tight™ bracket to the handlebar

\* Attach the bracket with its open end facing to the right.

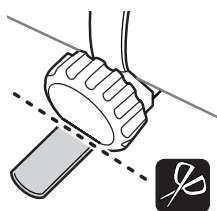
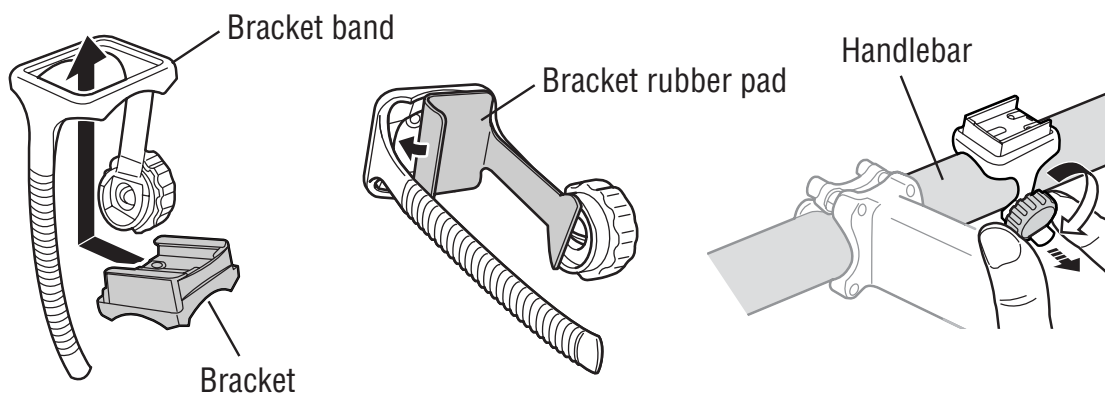

Cut extra length of the band with scissors.

### Caution:

Round off the cut edge of the bracket band to prevent injury.



## 2. Mount the speed sensor and magnet

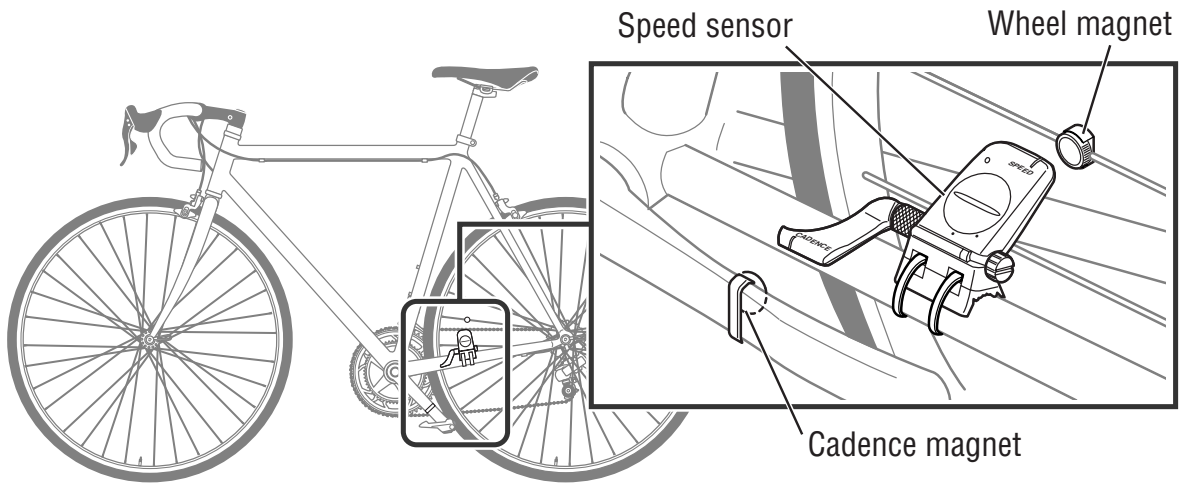

### 2-1. Temporarily secure the speed sensor

Locate the speed sensor on the left chain stay as shown above, and loosely secure it with the nylon ties.

- \* Do not tighten the nylon ties completely at this stage. Once a nylon tie is tightened, it cannot be pulled out.

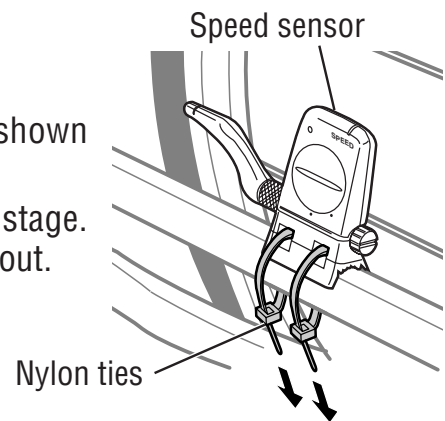

### 2-2. Mount the magnet

1. Loosen the setscrews both on the SPEED side and CADENCE side of the speed sensor, and turn the sensor to the angle as shown on the right.
2. Temporarily secure the wheel magnet to the spoke so that it faces the sensor zone on the SPEED side.
3. Temporarily secure the cadence magnet inside the crank with nylon ties, so that it faces the sensor zone on the CADENCE side.

- \* When the speed sensor is not positioned appropriately in respect to the two magnets (in both Steps 2 and 3), move the speed sensor back and forth so that it is positioned properly. After you move the speed sensor, adjust the position so that the two magnets face the relevant sensor zone.

4. After adjustment, tighten the nylon ties firmly to secure the speed sensor.

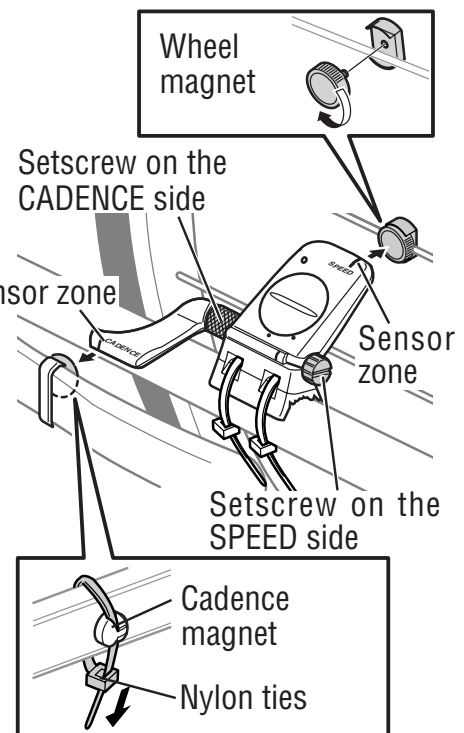

### 2-3. Adjust the distance to the magnet

1. Adjust the distance between the wheel magnet and the SPEED side of the speed sensor to be about 3 mm. After adjustment, tighten the setscrew on the SPEED side.
2. Adjust the distance between the cadence magnet and the CADENCE side of the speed sensor to be about 3 mm. After adjustment, tighten the setscrew on the CADENCE side.

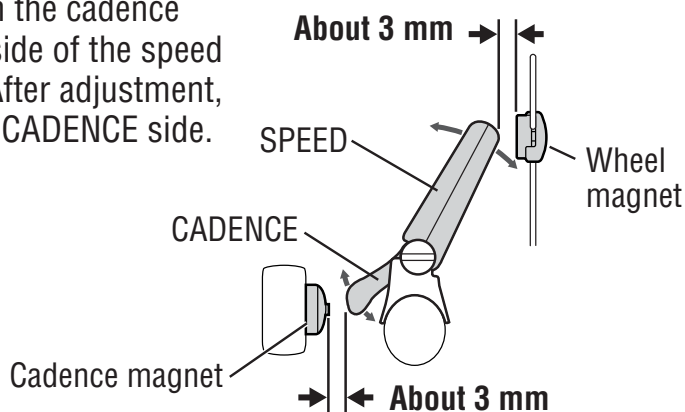

### 2-4. Securing various parts

Tighten the speed sensor, setscrew, and magnet firmly, and check for any looseness.

- \* For steel axle pedals, cadence magnet can be compactly installed onto the end face of the pedal axle. Make sure to remove the double-sided tape from the magnet when doing this.

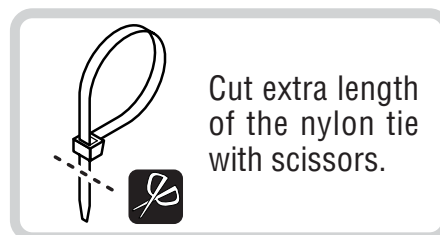

## 3. Remove/install the computer

### Caution:

When removing, hold the unit to prevent it from falling.

### Install

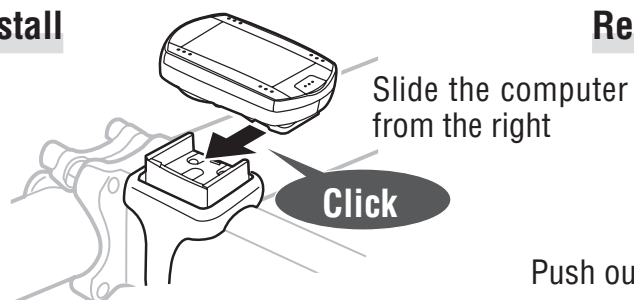

### Remove

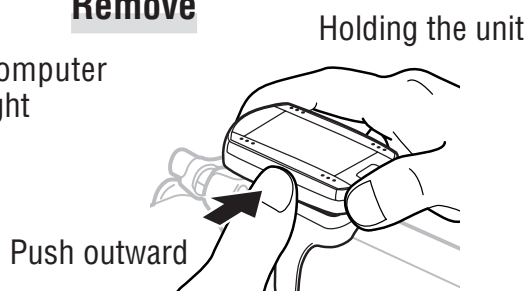

# Preparing the computer

Computer's basic items must be set up before using it.

## Removing the insulation sheet

When using the unit for the first time after purchasing, open the battery cover and remove the insulation sheet.

\* After you remove the insulation sheet, replace the battery cover in place.

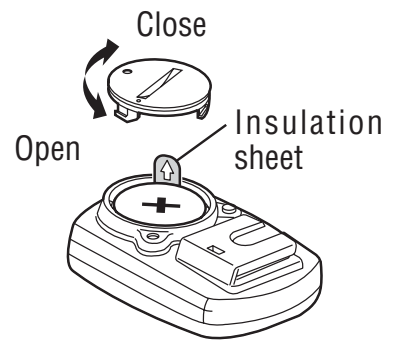

## Flow of set-up

There are 2 different set-up operations:

- Formatting operation: At initial purchase, or reset all to default.
- Restarting operation: When you replace batteries, or an error is displayed.

Each operation has a different flow of set-up.

### For formatting:

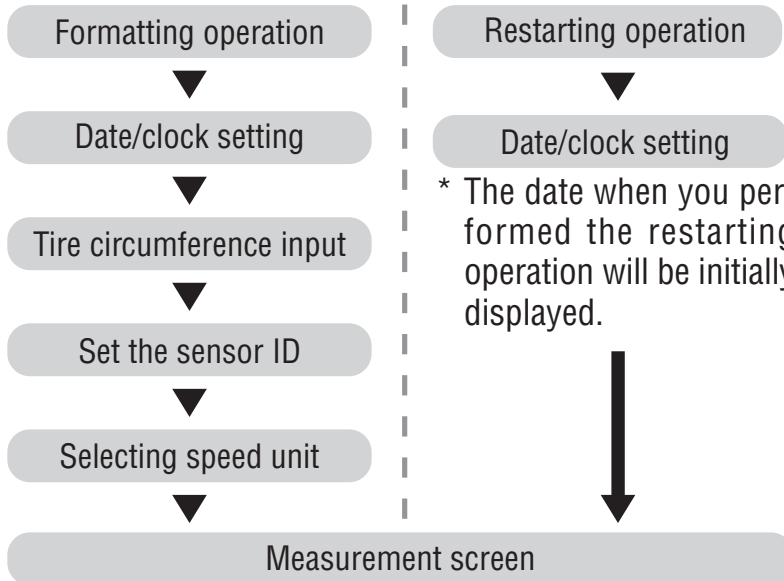

### For restarting:

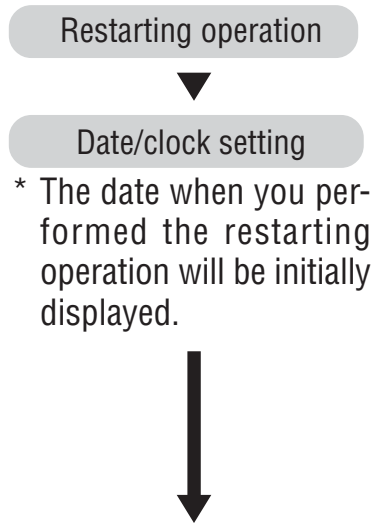

In the restarting operation, the following data are retained.

Measurement screen
Total time
Total distance
Menu screen
File data saved
Time format
Date
Tire circumference and wheel selection
Speed unit
Sensor ID
Auto-mode
Countdown distance
Sound
Setting the target zone

\* If mistake was made or “ID-ERROR” showed in the initial set up, go through the full initial set up steps first, and all corrections can be made afterwards through Menu screens. (page 22)

---

## 1. Formatting/Restarting operation

**Formatting operation** (At initial purchase, or reset all to default.)

**Caution:** All data are reset to the default and deleted.

---

1. While pressing the **MENU** button on the back of the computer, press **AC** button.  
Release the **MENU** button when a test pattern is displayed on the screen. The date/clock setting screen appears.  
Continue with date/clock setting.

Formatting operation:

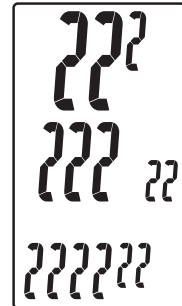
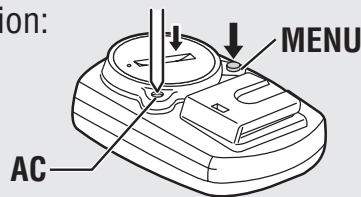

After a test pattern is displayed, all screen items light up.

---

- \* When all screen items light up without any test pattern displayed on the screen, the formatting operation has not been completed properly. Perform the formatting operation again.

**Restarting operation** (When you replace batteries, or an error is displayed.)

---

1. Press the **AC** button on the back of the computer.  
After all screen items light up for a second, the date/clock setting screen appears.  
Continue with date/clock setting.

Restarting operation:

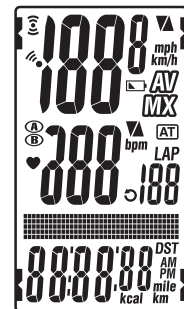
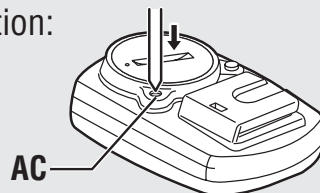

All screen items light up (for a second).

---



- \* Most of the settings and file data saved are retained for the restarting operation (see chart on page 9).

## 2. Date/Clock setting

Set the current date and time.

1. Select the date display format.

Select the date display format from “YY/MM/DD”, “MM/DD/YY”, and “DD/MM/YY” using the **M1/+** and **M2/-** buttons, and confirm with the **SSE** button.

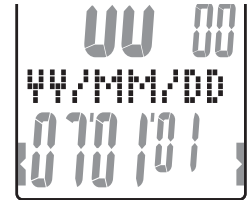

Switch the display:  **M1/+** (or)  **M2/-**

Confirm:  **SSE**



2. Enter the “Year”, “Month” and “Day.”

Enter the “Year”, “Month” and “Day” in the display order selected in Step 1 using the **M1/+** and **M2/-** buttons, and confirm with the **SSE** button. Enter the last 2 digits of the year.

Increase/decrease:  **M1/+** (or)  **M2/-**

Confirm:  **SSE**



3. Select the clock display format.

Select “24 hour” or “12 hour” using the **M1/+** and **M2/-** buttons, and confirm with the **SSE** button.

24h ↔ 12h:  **M1/+** (or)  **M2/-**

Confirm:  **SSE**



Display format



Hour Minute

4. Enter the “Hour” and “Minute.”

Enter the “Hour” using the **M1/+** and **M2/-** buttons, confirm with the **SSE** button, and then enter the “Minute” in the same way.

Increase/decrease:  **M1/+** (or)  **M2/-**

Confirm:  **SSE**

5. After you set the date/clock, press the **MENU** button to proceed to the next set up item.

For the formatting operation: To the “Tire circumference input” screen below  
 For the restarting operation: To the measurement screen and ready for use  **MENU** (Back)

### 3. Tire circumference input

Enter the tire circumference of the bicycle wheel in millimeter.

1. Enter the last 2 digits of the tire circumference.

Enter using the **M1/+** and **M2/-** buttons, and move digits using the **SSE** button. Then, enter the first 2 digits in the same way.

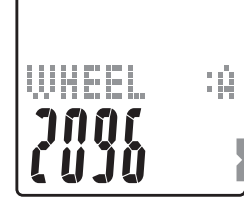
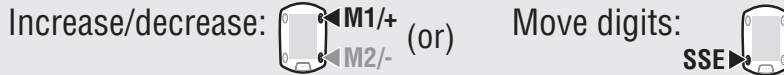

2. After completed, press the **MENU** button to proceed to “Set the sensor ID” below.



#### Tire circumference

You can find the tire circumference (L) of your tire size in the chart below, or actually measure the tire circumference (L) of your bicycle.

#### How to measure the tire circumference (L)

For the most accurate measurement, do a wheel roll out. With the tires under proper pressure, place the valve stem at the bottom. Mark the spot on the floor and with the rider's weight on the bike, roll exactly one wheel revolution in a straight line (until the valve comes around again to the bottom). Mark where the valve stem is and measure the distance in millimeter.

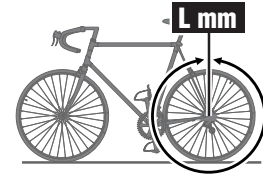

\* For your reference, use the tire circumference chart below.

Tire size	L (mm)	Tire size	L (mm)	Tire size	L (mm)
12 x 1.75	935	26 x 1(59)	1913	650 x 20C	1938
14 x 1.50	1020	26 x 1(65)	1952	650 x 23C	1944
14 x 1.75	1055	26 x 1.25	1953	650 x 35A	2090
16 x 1.50	1185	26 x 1-1/8	1970	650 x 38A	2125
16 x 1.75	1195	26 x 1-3/8	2068	650 x 38B	2105
18 x 1.50	1340	26 x 1-1/2	2100	700 x 18C	2070
18 x 1.75	1350	26 x 1.40	2005	700 x 19C	2080
20 x 1.75	1515	26 x 1.50	2010	700 x 20C	2086
20 x 1-3/8	1615	26 x 1.75	2023	<b>700 x 23C</b>	<b>2096</b>
22 x 1-3/8	1770	26 x 1.95	2050	700 x 25C	2105
22 x 1-1/2	1785	26 x 2.00	2055	700 x 28C	2136
24 x 1	1753	26 x 2.10	2068	700 x 30C	2146
24 x 3/4 Tubular	1785	26 x 2.125	2070	700 x 32C	2155
24 x 1-1/8	1795	26 x 2.35	2083	700C Tubular	2130
24 x 1-1/4	1905	26 x 3.00	2170	700 x 35C	2168
24 x 1.75	1890	27 x 1	2145	700 x 38C	2180
24 x 2.00	1925	27 x 1-1/8	2155	700 x 40C	2200
24 x 2.125	1965	27 x 1-1/4	2161	29 x 2.1	2288
26 x 7/8	1920	27 x 1-3/8	2169	29 x 2.3	2326

## 4. Set the sensor ID

Set the speed/cadence sensor ID.

- \* This unit requires the sensor ID in order for the computer to receive signal from the sensors.
- \* To set the sensor ID, be within 5 m from the bicycle with a speed/cadence sensor mounted properly (page 7).
- \* When performing ID Synch, make sure there is no other similar sensors in the surrounding area. (It may pick up other sensor's ID)

1. Verify that the speed/cadence sensor is mounted properly to the bicycle.
2. Press the **SSE** button to start searching the speed sensor ID. When the speed (cadence) is displayed as “**ID-OK**” on the screen by spinning the rear wheel or crank, searching is completed.

Start searching:



3. Press the **MENU** button to proceed to “Selecting speed unit” below.

To “Selecting speed unit”:

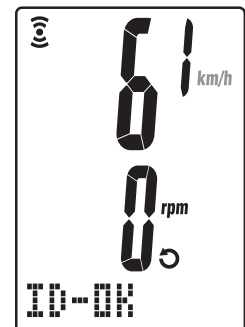
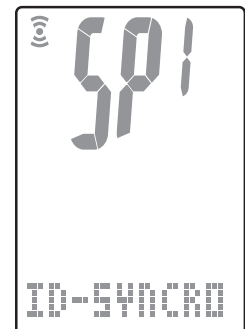

- \* This unit enters the search mode for 5 minutes after starting the ID check. Press the **SSE** button during the search mode, then “**ID-SKIP**” is indicated and it proceeds to “Selecting speed unit” screen below. Or, unless a sensor signal is received in 5 minutes, “**ID-ERROR**” is indicated and it proceeds to “Selecting speed unit” screen below. When “**ID-SKIP**” or “**ID-ERROR**” is indicated, this unit is not ready for measurement because the sensor ID has not been registered even though the set-up is completed. Be sure to check the sensor ID from the menu screen “Searching the sensor ID” (page 28).

## 5. Selecting speed unit

Select the speed unit from “km” and “mile”.

1. Select the speed unit.



km ↔ mile:  M1/+ (or)  M2/-



2. After selecting, press the **MENU** button. The measurement screen appears and the computer set-up is completed.

## 6. Operation test

Test the functioning of the speed sensor (SPEED) and the cadence sensor (CADENCE).

\* If the sensor signal icons,  and  are turned off, press the **M1/+** or **M2/-** button to turn them on.

### Speed sensor (SPEED)



1. Raise the rear wheel and spin the wheel.
2. When  flashes on the computer screen and the speed is displayed, it is operating normally.

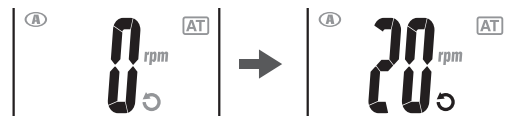

### Cadence sensor (CADENCE)

1. Turn the crank.
2. When  flashes on the computer screen and the cadence is displayed, it is operating normally.



\* When  or  does not flash, the position of the sensor and the magnet is not proper. Check and adjust the position of the sensor and magnet again (page 7).

**Important:** In the following situations, it is possible that other sensor's ID was picked up; (such can happen when performing ID Synch at the race venue or group rides)

- Does not display values, even though sensor/magnet position is proper

**Recommended Action:** Go to the computer's ID Synch setup screen (page 23) and go through the process of ID Synch. (Make sure that here is no similar devices in the vicinity. Signal transition distance can vary from environmental conditions such as weather, buildings, etc)

### Sensor signal status

If there is no incoming signal for approximately 5 minutes, the transmission stops and no longer receive the sensor data. Once you press the **M1/+** or **M2/-** button, the computer will come out of the Sleep mode and return to the Stand-by for sensor signal. Signal transmission status can be checked with Signal icon.

  (flashing) : Receiving sensor signal      (constant) : Stand-by for sensor signal  
  (off) : Transmission off



# Basic operation of the computer

## Functions on the measurement screen

The measurement screen displays 4 different types of data, which are switched by pressing the **M1/+** and **M2/-** buttons.

The display data are as follows.

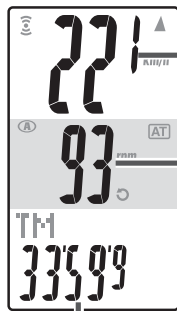

### Upper display data

Displays the data related to the speed.

### Middle display data

Displays the data related to the cadence.

Switch using the **M1/+** button

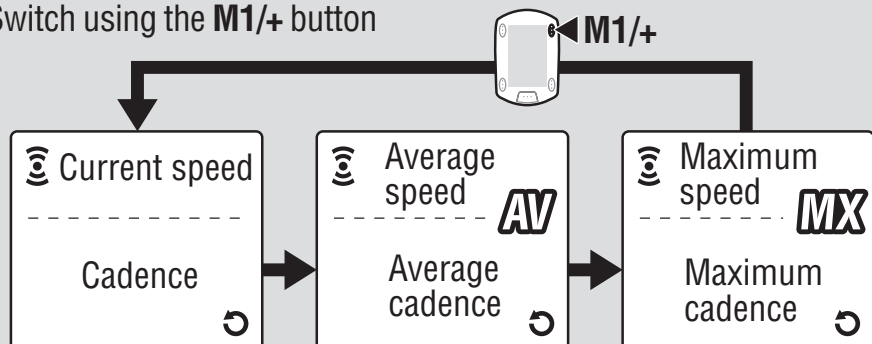

\* Upper and Middle display data are switched in sync together.

### Lower display data

Displays the other data.

Switch using the **M2/-** button

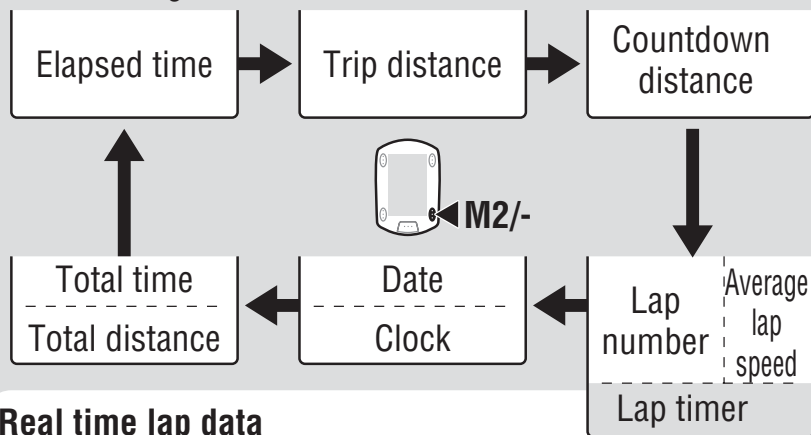

### Real time lap data (on-going lap data)

\* Pressing and holding the **M2/-** button while displaying the lap timer switches the lap timer to the lap distance. Pressing it again returns to the lap timer.

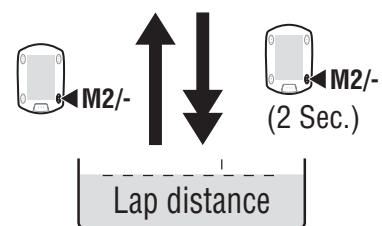

## Starting/Stopping the measurement

Initially, the unit starts or stops measurement automatically in sync with the bicycle motion. This is called auto-mode function. “km/h” or “mph” flashes during measurement.



The total distance, maximum speed, and maximum cadence are updated independently of starting/stopping measurement.





### Auto-mode function

When the auto-mode is turned on (**AT** lights up), the unit detects the wheel spinning, and starts/stops measurement automatically. When the auto-mode is turned off (**AT** lights off), the unit starts/stops measurement by using the **SSE** button.

\* For on/off of the auto-mode, see the menu screen “Setting the auto-mode” (page 31).

\* When the transmission is stopped and Sensor signal icons ,  are off (page 14), the main timer may not start due to speed signal not responding.

Press the **M1/+** or **M2/-** button to turn on the sensor signal icons , .



AT icon

## Backlight

Pressing the **LT** button illuminates the displays for about 3 seconds.

\* Pressing any button while backlight is still on extends the illumination for another 3 seconds.

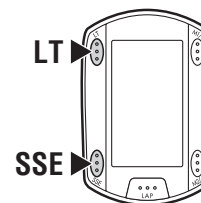

## Resetting the measurement data

To reset the measurement data (TM, DST, Lap Time, C.D. DST, etc) and the lap data, simultaneously press the **SSE** button and the **M1/+** or **M2/-** button in the measurement screen.

\* Resetting the measurement data saves the data automatically on a file. (page 23)

\* The screen will freeze for about 2 seconds after resetting; however, all measurements are operating normally, including the elapsed time.

\* The countdown setting (**C.D. DST**→) is returned to the manu set value you set.

\* Cannot reset for 5 seconds after pressing the **LAP** button.

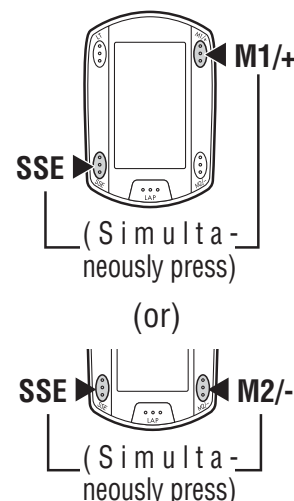

## Power-saving function

When the computer does not receive any data for 5 minutes, it will enter the power-saving mode, in which only the date/clock is displayed. By pressing any buttons except the **AC** recovers from the power-saving mode, and the measurement screen appears. You must press a button when the computer is in power saving mode before it will start to measure any data.



Power-saving mode

# Measurement screen

## Upper and middle display data

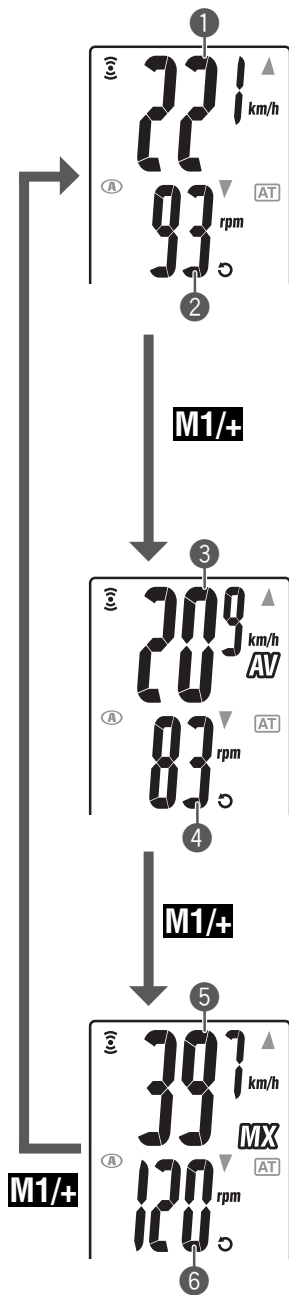

### ① Current speed

Displays the current speed.  
Updated every second.

### ② Cadence

Displays the number of pedal rotations per minute.  
Updated every second.

### ③ Average speed <sup>\*1</sup>

Displays the average speed after the start of measurement.

### ④ Average cadence <sup>\*2</sup>

Displays the average cadence after the start of measurement.  
\* The average will not be reflected when you stop pedaling.

### ⑤ Maximum speed

Displays the maximum speed after the start of measurement.  
Updated independently of starting/stopping measurement.

### ⑥ Maximum cadence

Displays the maximum cadence after the start of measurement.  
Updated independently of starting/stopping measurement.

\*1: When the trip distance (**DST**) exceeds 10,000 km [mile], or the elapsed time (**TM**) exceeds 100 hours, [**E**] appears indicating further measurement is impossible. Clear the data by resetting (page 16).

\*2: This device calculates the average excluding the time when you stop pedaling. This feature produces actual averages, which are different from those with conventional models that calculate it for the entire measurement time period.

## Lower display data

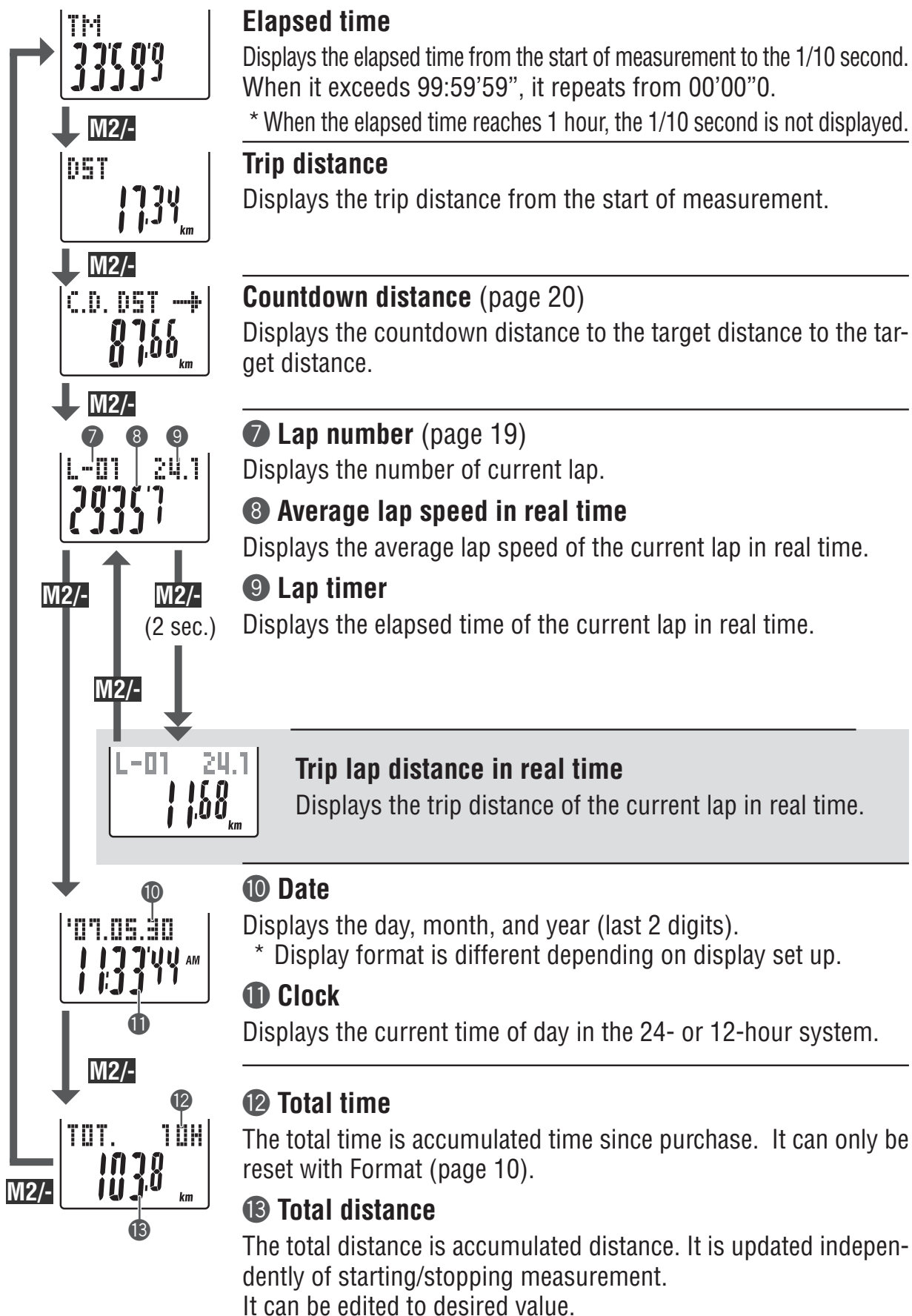

## Pace function

2 types of pace arrow icons for the current speed and the cadence are displayed on the screen.

These arrow icons indicate whether the current speed (cadence) is above or below the average speed (average cadence).

- ▲ : Appears when the current value is above the average.
- ▼ : Appears when the current value is below the average.
- No arrows : When the current value is equal to the average, or zero.

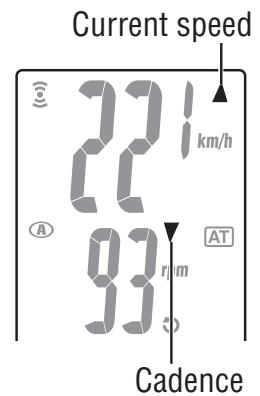

## Lap function

Pressing the **LAP** button on the measurement screen during measurement records the data between a given set of points (average lap speed/maximum lap speed, average lap cadence/maximum lap cadence, lap time/split time, and trip lap distance) up to 99 points. Immediately after recording, the lap data are displayed in the order as shown below, and then return to the measurement screen.

### Measurement screen

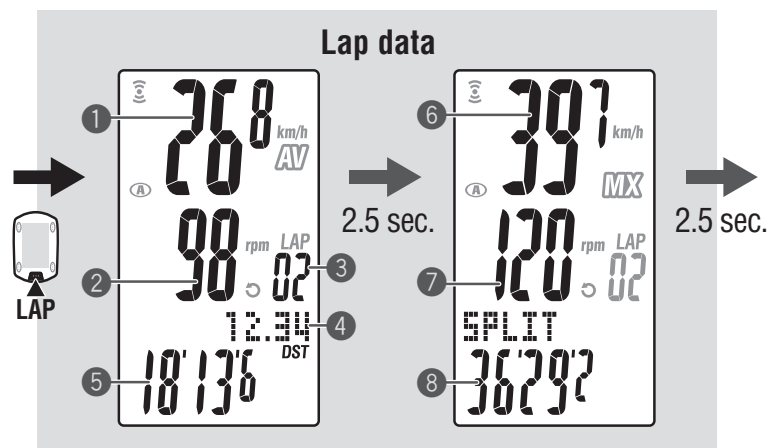
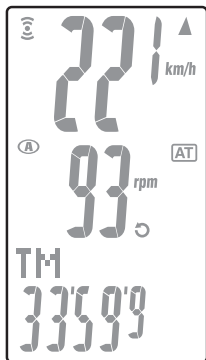

### Measurement screen

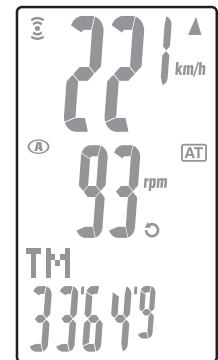

#### 1 Average lap speed

#### 2 Average lap cadence

Displays the average lap speed (average lap cadence) from the previous point (for **L-01**: from the start of measurement).

#### 3 Lap number

Displays the lap number just recorded.

\* When the total number of laps exceeds 99 points, "--" appears indicating further lap recording cannot be done.

#### 4 Trip lap distance

Displays the trip lap distance from the previous point (for **L-01**: from the start of measurement).

#### 5 Lap time

Displays the elapsed time from the previous point (for **L-01**: from the start of measurement).

#### 6 Maximum lap speed

#### 7 Maximum lap cadence

Displays the maximum lap speed (maximum lap cadence) from the previous point (for **L-01**: from the start of measurement).

#### 8 Split time

Displays the total elapsed time from the start of measurement.

## Lap time and split time

The lap time displays elapsed time from the last press of the **LAP** button.

The split time displays the elapsed time from the start of measurement to the point **LAP** button is pressed.

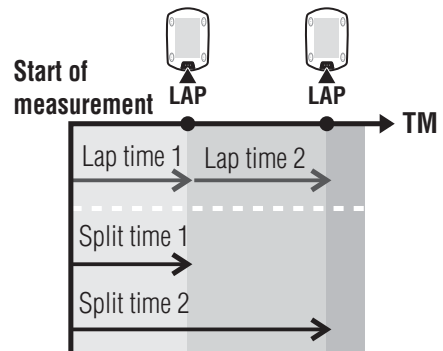

- \* The measured lap data is saved to a file when you perform a reset operation (page 16) and can be reviewed in “File view” (page 23).
- \* Pressing the **LAP** button while the total number of laps reaches 99 points displays the lap data, but “--” appears in place of the lap number indicating further recording is impossible.

## Advance use of the real time lap data

For the real time lap data indicated in the lower display, the unit starts/stops measurement in sync with the main time measurement; however, it resets and restarts the data every time you press the **LAP** button.

This independent feature of lap time can be useful also for intervals and sectional trials such as hill climb section.

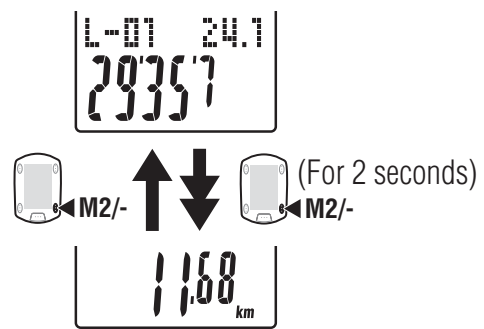

## Countdown distance

The countdown distance feature displays the countdown distance to a predetermined target trip distance, and notifies when it reaches zero. When it reaches the target trip distance, the unit switches any measurement data to the countdown data, and notifies it by flashing the numeric/dot display and an alarm sound.

### Example of how the countdown distance is used

#### 1. Entering the race event distance

For distance system events such as a road race and century ride, enter the race event distance before the start, and develop your strategy and pace based on the countdown distance during the race.

#### 2. Entering the destination sign distance

For touring, enter the sign distance whenever you encounter a destination sign along the road, and develop your pace based on the countdown distance.

#### 3. Entering the periodical target distance

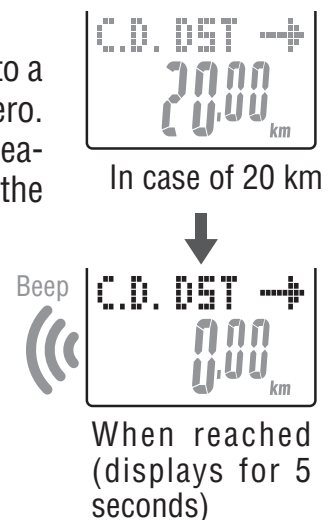

Enter the periodical target distance for a week, month, or year to check your progress.

- \* The target trip distance is set from the menu screen “Setting the countdown distance” (page 31).



## Target cadence zone

During measurement,  on the screen displays the target cadence zone status.

-  (constant) : The target zone is turned on.
-  (flashing) : The current cadence is out of the zone.
-  (off) : The target zone is set to off.

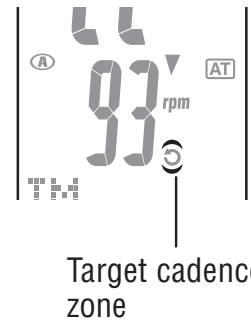

\* The target cadence zone set from the menu screen “Setting the target cadence zone” (page 33).

# Changing the computer configuration

Pressing the **MENU** button in the measurement screen switches to the menu screen. In the menu screen, you can view and delete the files saved, and view and change various configurations.

\* Use the **M1/+** and **M2/-** to change menu items.

\* After changes are made, be sure to review the setting(s) and confirm by pressing the **MENU** button.

\* Leaving the menu screen without any operation for 2 minutes returns to the measurement screen, and changes are not saved.

## Measurement screen (Back)

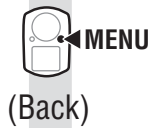
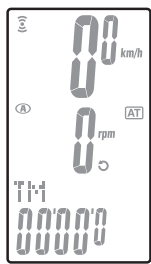

## Menu top screen

<b>FILE VIEW</b> File view	Viewing and deleting files	(page 23)
<b>CLOCK DATE</b> Setting the clock/date	Changing the clock/date	(page 27)
<b>WHEEL</b> Wheel selection and changing the tire circumference	Selecting wheel and changing the tire circumference	(page 28)
<b>SENSOR-ID</b> Searching the sensor ID	Synchronizing the speed sensor ID	(page 28)
<b>UNIT</b> Setting the measurement unit	Changing the measurement unit	(page 30)
<b>ODO INPUT</b> Total distance manual entry	Total distance input	(page 30)
<b>AUTO MODE</b> Setting the auto-mode	On/off of the auto-mode	(page 31)
<b>C.D. DST</b> Setting the countdown distance	Countdown distance input	(page 31)
<b>SOUND</b> Setting sound	On/off of the CDC alarm, and button operation sound	(page 32)
<b>CDC.ZONE</b> Setting the target cadence zone	Changing the upper/lower zone limit	(page 33)



## File view

## FILE VIEW

The lap and measurement data are saved into a file automatically each time a ride is reset (Resetting Operation page 16)

With the file view, you can review the past rides or delete data recorded.

### Measurement data to be recorded in a file

The computer can record up to 14 files<sup>\*1</sup>.

When 14 files (rides) are saved, the oldest one is deleted automatically. The latest file is always **F-01**.

The measurement data to be saved in a file are as follows.

### Date of creation:

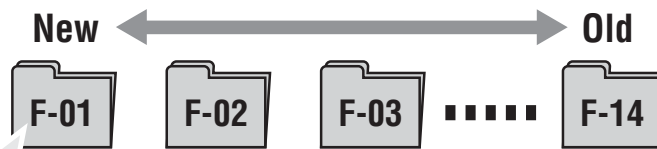

- Trip distance
- Elapsed time
- Various average values (average speed, and average cadence)
- Various maximum values (maximum speed, and maximum cadence)
- Date and time of file creation (date/time when the measurement started)
- Number of laps used
- Time distribution to the target zone (time in the zone, time above the zone, and time below the zone) and the percentage (%)
- Lap data (average lap speed, average lap cadence, maximum lap speed, maximum lap cadence, lap time, split time, trip lap distance)

\*1: One lap per file is used even in the case there is no lap data. Therefore, when the total number of laps reaches 99 points, no more files can be saved.

### Viewing the measurement data in a file

View the measurement data in a file saved in the computer.

1. Press the **MENU** button in the measurement screen to switch to the menu top screen.

Press the **SSE** button on the **FILE VIEW** screen.

Menu top:  MENU  
(Back)

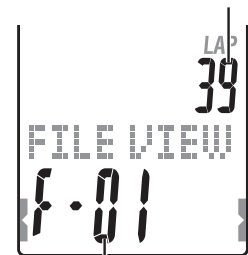

Confirm:  SSE

Total number of laps



Total number of files

2. Select the file using the **M1/+** and **M2/-** buttons, and confirm with the **SSE** button.

Switching the file number:  **M1/+** (or)  **M2/-**

3. Scroll through the data saved in each file by pressing the **SSE** button.  
The display items are as follows.

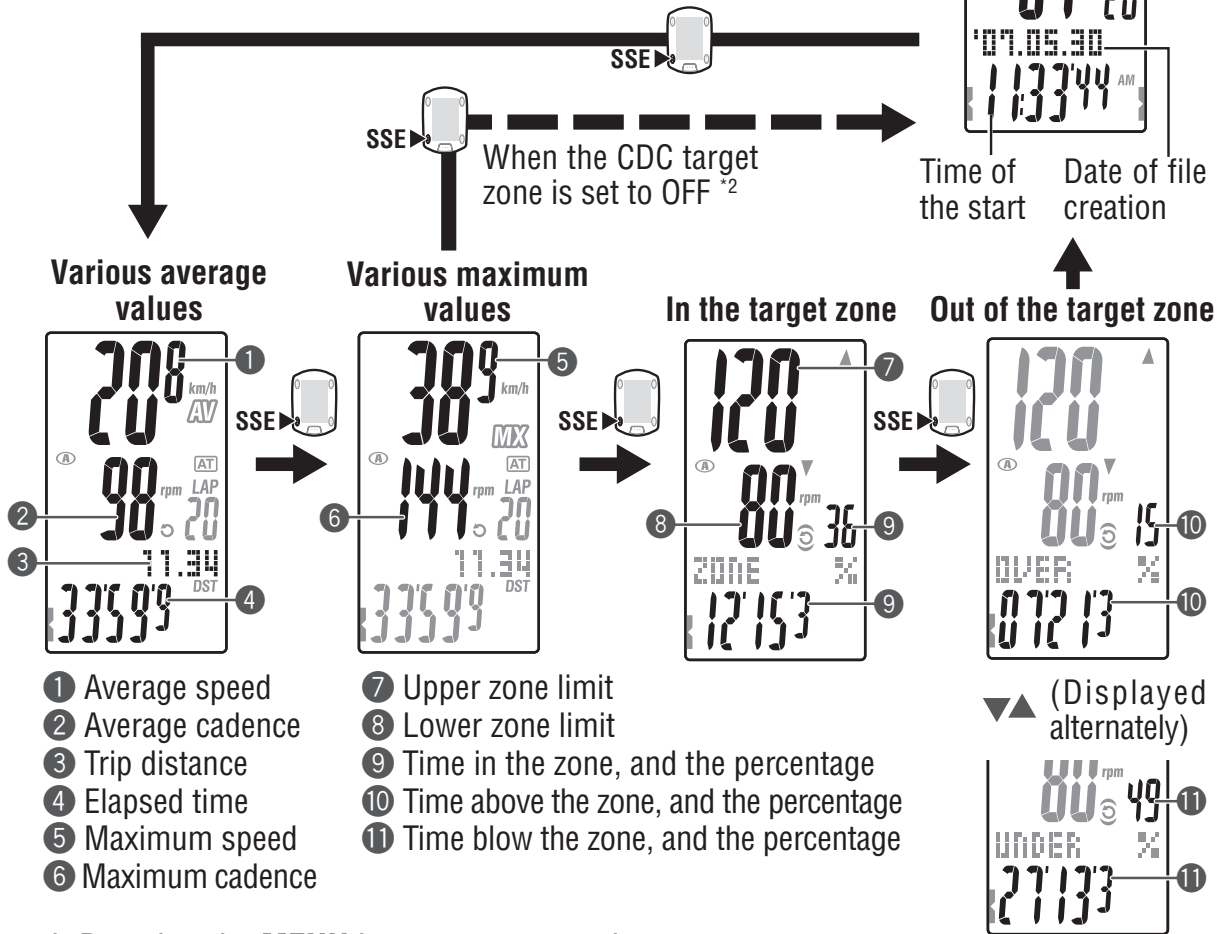

4. Pressing the **MENU** button returns to the menu top screen (**FILE VIEW** screen). Pressing it again returns to the measurement screen.

To the menu top/measurement screen:  **MENU** (Back)

\*2: CDC target zone is set to **OFF** during measurement, no data related to the target zone is displayed.

\* Pressing the **LAP** button while viewing some data switches to viewing the lap data (page 25).

## Viewing the lap data

View the lap data in a file saved in the computer.

Select the file number you want to view from the menu screen “File view” (page 23).

1. Press the **LAP** button to view the lap data contained in the file selected.  
Press the **LAP** button again to return from the lap data.  
The average and maximum values are displayed alternately as follows.

Viewing/exiting lap data: 

**Average values**

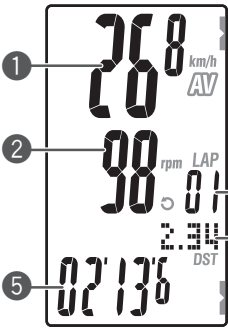

**Maximum values**

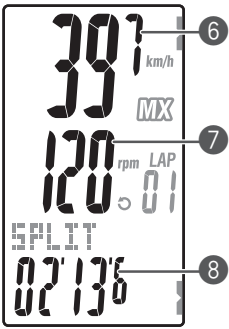

① Average lap speed  
② Average lap cadence  
③ Lap number  
④ Trip lap distance  
⑤ Lap time  
⑥ Maximum lap speed  
⑦ Maximum lap cadence  
⑧ Split time

(Displayed alternately)

File number

Number of laps used in a file

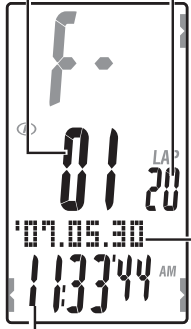

Date of file creation

Time of the start

2. Switch the laps, if applicable, using the **M1/+** and **M2/-** buttons.

Switching the lap number:  (or)

3. Pressing the **MENU** button returns to the menu top screen (**FILE VIEW** screen). Pressing it again returns to the measurement screen.

To the menu top/measurement screen:  **MENU**  
(Back)

## Deleting files

Delete the file saved in the computer.

You can select deleting only the file specified, or all files.

Switch to the menu screen "File view" (page 23).

1. Simultaneously press the **SSE** button and the **M1/+** or **M2/-** button to switch to the deleting screen.

Switching to the deleting screen:

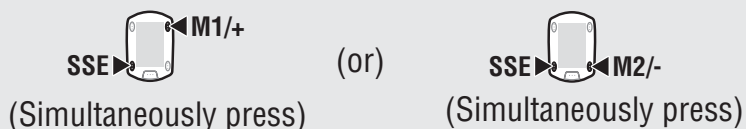

File number

Number of laps used in a file



Date of file creation

Time of the start

2. Select the file number you want to delete from the date/clock of file creation. To delete all files, select "aLL".

Switching the file number: **01** ↔ **02** ↔ **03** ... **aLL** ↔ **01**

Searching delete screen



3. Press the **SSE** button to delete the file.

Deleting files: **SSE**

(Displayed alternately)

4. Pressing the **MENU** button returns to the menu top screen (**FILE VIEW** screen). Pressing it again returns to the measurement screen.

To the menu top/measurement screen: **MENU** (Back)



- \* When the computer has no files (**F-00**) the delete file operation is not operable.
- \* Once a file is deleted, all lap data associated with that file is also deleted.
- \* Once a file is deleted, it cannot be restored.

## Setting the clock/date

### CLOCK.DATE

Set the “Clock display format”, “Hour”, “Minute”, “Date display format”, “Year”, “Month” and “Day.”

1. Press the **MENU** button in the measurement screen to switch to the menu top screen.

Switch to the **CLOCK.DATE** screen using the **M1/+** and **M2/-** buttons, and confirm with the **SSE** button.



Menu top:



Changing the menu:



Confirm:



2. Select the clock display format.

Select “24 hour” or “12 hour” using the **M1/+** and **M2/-** buttons, and confirm with the **SSE** button.

Display format

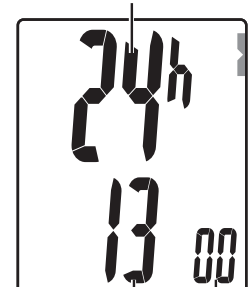

24h ↔ 12h:

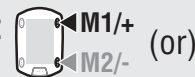

Confirm:



3. Enter the “Hour” or “Minute.”

Enter the “Hour” using the **M1/+** and **M2/-** buttons, confirm with the **SSE** button, and then enter the “Minute” in the same way.

Hour Minute

Increase/decrease:



Confirm:



4. Select the date display format.

Select the date display format from “YY/MM/DD”, “MM/DD/YY”, and “DD/MM/YY” using the **M1/+** and **M2/-** buttons, and confirm with the **SSE** button.



Switch the display:



Confirm:



5. Enter the “Year”, “Month” and “Day.”

Enter the “Year”, “Month” and “Day” in the display order selected in Step 4 using the **M1/+** and **M2/-** buttons, and confirm with the **SSE** button. Enter the last 2 digits of the year.



Increase/decrease:



Confirm:



6. Pressing the **MENU** button returns to the menu top screen (**CLOCK.DATE** screen), and confirm the change(s).

Pressing it again returns to the measurement screen.

To the menu top/measurement screen:



## Wheel selection and tire circumference

WHEEL

Switch the Wheel Size (**A** / **B**), and change the Tire Size (tire roll out length).

\* For the tire size, see “Tire circumference” (page 12).

1. Press the **MENU** button in the measurement screen to switch to the menu top screen.  
 Switch to the **WHEEL** screen using the **M1/+** and **M2/-** buttons, and confirm with the **SSE** button.

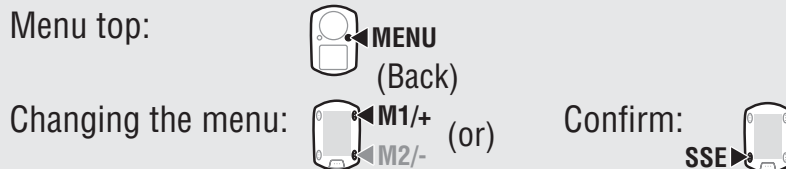

Wheel selection

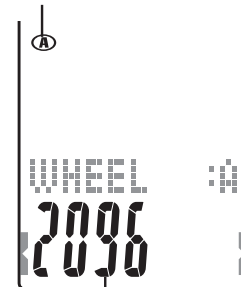

Current wheel size

2. Select the Wheel Size “**A**” or “**B**” using the **M1/+** and **M2/-** buttons.

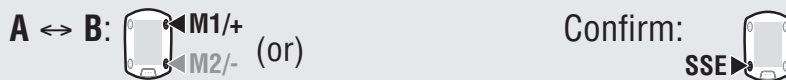

At this point if change of tire circumference is not necessary, you can escape the setup by pressing the **MENU** button.

3. Enter the last 2 digits of the tire circumference for the wheel selected in Step 1 using the **M1/+** and **M2/-** buttons, and confirm with the **SSE** button.

Then, enter the first 2 digits in the same way.

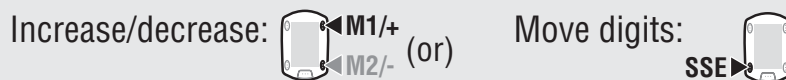

4. Pressing the **MENU** button returns to the menu top screen (**WHEEL** screen), and confirm the change(s).  
 Pressing it again returns to the measurement screen.



## Searching the sensor ID

SENSOR-ID

Receive and check the ID signal transmitted from the speed/cadence.

- \* This unit requires the sensor ID.  
 The computer cannot receive the sensor signal unless the sensor ID is synchronized properly.
- \* To synchronize the sensor ID, be within 5m from the bicycle with a speed/cadence sensor mounted properly (page 7).
- \* When searching the sensor ID, make sure no other sensors are in the area within 10 m radius.  
 It is also possible to press the Reset button on the Speed/Cadence sensor to intentionally turn off the signal transmission from the sensor.

1. Press the **MENU** button on the measurement screen to switch to the menu top screen.  
Switch to the **SEnSOR-ID** screen using the **M1/+** and **M2/-** buttons, and confirm with the **SSE** button.



Menu top:



Changing the menu:



(or)

Confirm:



2. Select the sensor ID to be checked.  
Select "**SP1** (speed sensor 1)" and "**SP2** (speed sensor 2)" using the **M1/+** and **M2/-** buttons.

Selecting the sensor:



(or)

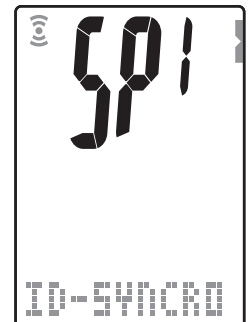

3. Check whether the speed/cadence is mounted properly.
4. Press the **SSE** button to start searching the ID.  
When the speed (cadence) is displayed as "**ID-OK**" on the screen by spinning the rear wheel or crank, synchronizing is completed.

Start searching:

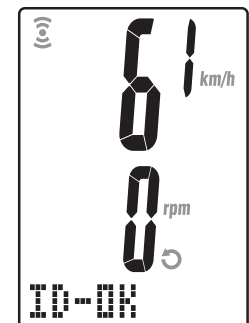

5. Pressing the **MENU** button returns to the menu top screen (**SEnSOR-ID** screen), and confirm the change.  
Pressing it again returns to the measurement screen.

To the menu top/measurement screen:



- \* This unit enters the search mode for 5 minutes after starting the ID synch. While "**ID-SKIP**" is indicated, press the **SSE** button in the search mode to cancel the ID synch, and "**ID-SKIP**" is displayed. Unless a sensor signal is received in 5 minutes, "**ID-ERROR**" is displayed. When "**ID-SKIP**" or "**ID-ERROR**" is displayed, the ID has not been synchronized properly. In such a case, the sensor ID retains the previous ID setup. Check whether the speed/cadence is mounted properly, is mounted properly, before you check the ID again.
- \* **SP2** is used when a computer is commonly used for second bicycles. By synchronizing the ID of the second bicycle equipped with a second speed/cadence sensor and the computer with **SP2**, re-synchronizing the ID is not required every time you move the computer between first and the second bike.

## Setting the measurement unit

UNIT

Change the unit (**km** or **mile**).

\* Stop measurement and perform the resetting operation (page 16) before you change the unit. Unless you perform the resetting operation, “**DATA RESET**” appears on the screen, preventing from changing the unit.

1. Press the **MENU** button in the measurement screen to switch to the menu top screen.  
 Switch to the **Unit** screen using the **M1/+** and **M2/-** buttons, and confirm with the **SSE** button.

Menu top:



Changing the menu:



Confirm:



Current speed unit

2. Select the speed unit using the **M1/+** and **M2/-** buttons.

**km** ↔ **mile**: (or)



3. Pressing the **MENU** button returns to the menu top screen (**UNIT** screen), and confirm the change(s).  
 Pressing it again returns to the measurement screen.

To the menu top/measurement screen: (Back)

\* After the unit is switched, the total distance measured in the past is automatically converted to the new unit.

## Total distance manual entry

ODO INPUT

You can enter any value to the total distance.

The total distance in the past can be input after formatting or to a new computer.

1. Press the **MENU** button in the measurement screen to switch to the menu top screen.  
 Switch to the **ODO InPUT** screen using the **M1/+** and **M2/-** buttons, and confirm with the **SSE** button.

Menu top:



Changing the menu:



Confirm:



Current total value

2. Enter the total distance using the **M1/+** and **M2/-** buttons, and move digits using the **SSE** button.

\* The total distance shall be entered with a positive value.

Increase/decrease:



Move digits:







- Pressing the **MENU** button returns to the menu top screen (**ODO InPUT** screen), and confirm the change(s). Pressing it again returns to the measurement screen.

To the menu top/measurement screen: MENU (Back)

## Setting the auto-mode

### AUTO MODE

Switch on/off of the auto-mode (page 16).

- Press the **MENU** button in the measurement screen to switch to the menu top screen. Switch to the **AUTO MODE** screen using the **M1/+** and **M2/-** buttons, and confirm with the **SSE** button.



Current setting

Menu top: MENU (Back)  
 Changing the menu: M1/+ (or) M2/- Confirm: SSE

- Select **On** or **OFF** using the **M1/+** and **M2/-** buttons.

**On** ↔ **OFF**: M1/+ (or) M2/-



- Pressing the **MENU** button returns to the menu top screen (**AUTO MODE** screen), and confirm the change(s). Pressing it again returns to the measurement screen.

To the menu top/measurement screen: MENU (Back)

## Setting the countdown distance

### C.D. DST →

Enter the target trip distance for the countdown (page 20).

- Press the **MENU** button in the measurement screen to switch to the menu top screen. Switch to the **C.D. DST** screen using the **M1/+** and **M2/-** buttons, and confirm with the **SSE** button.



Current setting

Menu top: MENU (Back)  
 Changing the menu: M1/+ (or) M2/- Confirm: SSE



2. Enter the target distance using the **M1/+** and **M2/-** buttons, and move digits using the **SSE** button.

\* The target distance can be set to the 0.1 km.

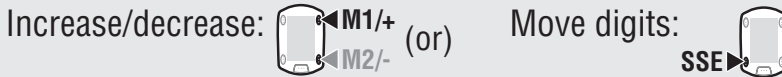

Target distance  
In case of 100.0 km

3. Pressing the **MENU** button returns to the menu top screen (**C.D.DST**→ screen), and confirm the change(s). Pressing it again returns to the measurement screen.

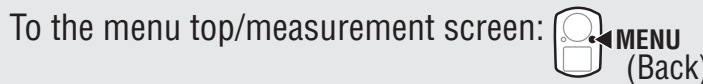

## Setting sound

## SOUND

Switch on/off of the target zone alarm sound and button operation sound.

1. Press the **MENU** button on the measurement screen to switch to the menu top screen. Switch to the **SOUND** screen using the **M1/+** and **M2/-** buttons, and confirm with the **SSE** button.

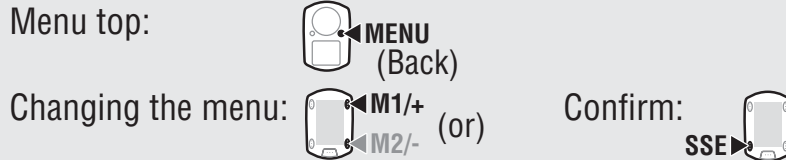

2. Switch between the CDC out of zone alarm and button operation using the **SSE** button.



CDC zone alarm



3. Select **On** or **OFF** using the **M1/+** and **M2/-** buttons.



Button operation sound



4. Pressing the **MENU** button returns to the menu top screen (**SOUND** screen), and confirm the change(s). Pressing it again returns to the measurement screen.

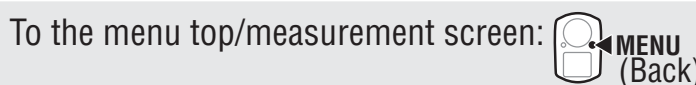

## Setting the target cadence zone

CDC.ZONE

You can set the target cadence zone on/off and change the upper/lower limit of the target cadence zone.

- \* Stop measurement and perform the resetting operation (page 16) before you can change the target cadence zone. Unless you perform the resetting operation, “**DATA RESET**” appears on the screen, preventing from changing the target cadence zones.
- \* For details of the target zone, see “Use of the target zone” (page 34).

1. Press the **MENU** button in the measurement screen to switch to the menu top screen.

Switch to the **CDC.ZONE** screen using the **M1/+** and **M2/-** buttons, and confirm with the **SSE** button.

Menu top:



Changing the menu:



Confirm:



Current setting

2. Select on/off of the target cadence zone using the **M1/+** and **M2/-** buttons.

When using the target cadence zone, select “**On**”, confirm with the **SSE** button, and then proceed to Step 3.

When not using the target zone, select “**OFF**”, and then proceed to Step 4.

On ↔ OFF:



Confirm:

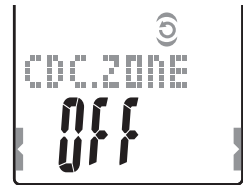

Upper limit

3. Enter the lower zone limit using the **M1/+** and **M2/-** buttons, press the **SSE** button, and then enter the upper limit in the same way.

Increase/decrease:



Confirm:



Lower limit

4. Pressing the **MENU** button returns to the menu top screen (**CDC.ZONE** screen), and confirm the change. Pressing it again returns to the measurement screen.

To the menu top/measurement screen:



- \* You can enter any upper/lower limit; however, the upper limit is adjusted automatically to the lower limit + 1 when the entered lower limit exceeds the upper limit. In case of the upper limit, vice versa, the lower limit is adjusted in the same way.

## Use of the target zone

When the target cadence zone is turned **On**, cadence is monitored against set zone range. When the cadence is out of the zone during measurement, the computer sounds an alarm and notifies a rider by flashing .

For training aiming at a cadence of 80 to 120 rpm, set the lower limit to 80 and upper limit to 120.

Then, the computer emits an alarm when the cadence falls below 79 rpm, or rises above 121 rpm.

Once the target zone is set to **On**, the relevant data are recorded to the file and the time in zone, the time above the zone, and time below the zone and their percentages can be viewed in the file view (page 23).

### Cadence zone

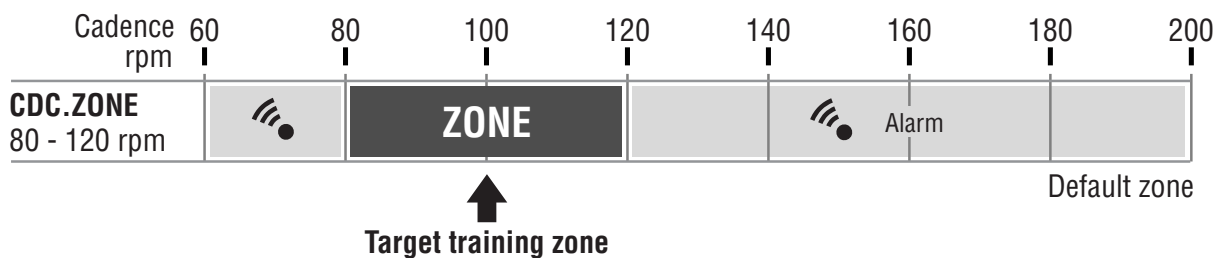







- \* You can enter any upper/lower limit to the zone.
- \* For the target zone, you can change on/off and the upper/lower limit of the target zone from the menu screen “Setting the target cadence zone” (page 33).
- \* On/off of the alarm sound is selected from the menu screen “Setting sound” (page 32).

## Trouble shooting

If a malfunction occurs, check the following before contacting CatEye or your retailer for repair or service.

### Trouble on display

Trouble	Check Items	Remedy
Display motion becomes slower.	Is the surrounding temperature low (below zero degree Celsius or 32 degrees Fahrenheit)?	Temperatures below freezing may result in slower screen response. Data is not affected.
 Flashes on the screen.	The remaining battery capacity for the computer is low.	Replace it with a new battery (CR2032) immediately. After replacement, be sure to perform the restarting operation (page 10).
No displays appear.	Is the battery for the computer empty?	Replace it with a new battery (CR2032). After replacement, be sure to perform the restarting operation (page 10).
Meaningless display appears.		Perform the restarting operation (page 10).
Cannot measure the trip speed (cadence)	Have you checked the sensor ID? Is the computer ID Synch'ed with somebody else's sensor?	Check the speed sensor ID (page 28) for <b>SP1</b> (speed sensor 1) or <b>SP2</b> (speed sensor 2).
	Is the Speed and Cadence sensor icon on  ,  ?	If the Speed and Cadence sensor icon is off  ,  , the computer cannot receive data. Press the <b>M1/+</b> or <b>M2/-</b> button once to turn on the icon.
	Check whether the distance between the speed (cadence) sensor and the magnet is too large.	Adjust the position of the speed (cadence) sensor and that of the magnet correctly. (See "How to install the unit on your bicycle" on page 6.)
	Is the sensor zone of the speed (cadence) sensor off the center of the magnet?	
	Has the power-saving function been activated, showing only date/clock on the screen?	Press any button on the computer to cancel the power-saving function.
	Is the battery for the speed sensor empty?	Replace it with a new battery (CR2032). After replacement, be sure to press the <b>RESET</b> button on the speed sensor.
Pressing the <b>LT</b> button does not turn on a light.	Check whether  lights up on the computer screen. The remaining battery capacity for the computer is low.	Replace it with a new battery (CR2032). After replacement, be sure to perform the restarting operation (page 10).

## Trouble on operation

Trouble	Check Items	Remedy
Pressing the <b>SSE</b> button does not start/stop measurement.	Check whether the auto-mode is turned on (with <b>AT</b> illuminating).	When <b>AT</b> illuminates, the auto-mode is on; you cannot start or stop measurement by pressing the button. Turn off the auto-mode. (See “Setting the auto-mode” on page 31.)
The speed/cadence sensor ID synch failed.		The battery for the speed sensor is possibly depleted. After replacing the battery with a new one (CR2032), check the sensor ID again (page 28).
Lap data cannot be stored.	Have you already completed 99 laps?	Delete data files that contain several laps from the file view (page 26) in order to obtain free space for lap recording.
	Is the lap time over 100 hours (Or is the trip lap distance over 9999.99 km)?	With the recording range exceeded, the lap cannot be measured. Perform the resetting operation (page 16) for further measurements.
	Is it immediately after pressing the <b>LAP</b> button?	You cannot record the lap for 5 seconds immediately after pressing the <b>LAP</b> button.
Abnormal values appear.	Are there any objects emitting electromagnetic waves (railway tracks, transmitting stations for television, etc.) nearby?	Keep the unit away from any object that may be causing interference, and reset the data (page 16).
In menu mode, cannot change settings.	Is it currently measurement?	Only top menu can be viewed during measurement.
	When the auto-mode is turned on (with <b>AT</b> illuminating), it may enter the measurement mode due to electromagnetic waves.	Keep the unit away from any object that may be causing interference with electromagnetic waves.
	Is it the target zone or the measurement unit that cannot be changed?	To change the target zone and measurement unit, the resetting operation is required. Stop measurement, and perform the resetting operation (page 16).
Measurement data cannot be stored on the file view.	Has the total number of laps reached 99 points?	Delete data files that contain several laps from the file view (page 26) in order to obtain free space for lap recording.

## Replacing battery

The product comes with factory-installed batteries. When a battery is empty, replace it with a new one according to the following instructions.

### **Warning!!! :**

Safely dispose of the old batteries, and do not place them within reach of children. If a battery is swallowed, consult a doctor immediately.

- \* When any battery for the computer, or speed/cadence sensor depleted, we recommend replacing all batteries at the same time.
- \* The battery life shown in this manual is not definitive and it varies depending on the use environment.
- \* The battery cover sealing is critical to maintain the waterproof feature. Clean any contamination on the battery cover or the seal, and check whether it seals correctly.

### Computer

Battery life: Approx. 1 years when used for 1 hour per day.

- \* When the remaining battery capacity is low,  lights up.

1. Remove the battery cover on the back of the computer using a coin, or the equivalent.
2. Insert new lithium batteries (CR2032) with the (+) sign upward, and close the battery cover firmly.
3. After replacement, be sure to perform the restarting operation (page 10), and set the date and time.

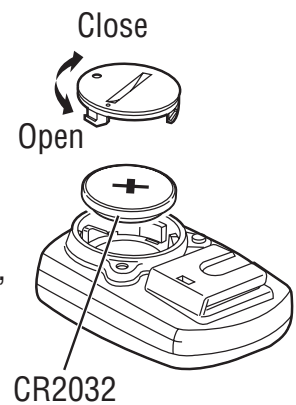

### Speed sensor

Battery life: Approx. 1 years when used for 1 hour per day.

1. Remove the battery cover on the speed sensor using a coin, or the equivalent.
2. Insert new lithium batteries (CR2032) with the (+) sign upward, and close the battery cover firmly.
3. After replacement, be sure to press the **RESET** button on the speed sensor, and check that the positions of the magnet and sensor are correct and they are secured firmly.

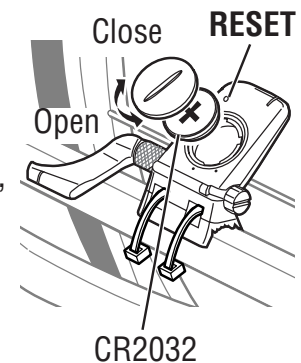

# Maintenance

Perform the daily care according to the following instructions.

- Regularly check that the positions of the magnets and sensors are correct, and they are secured firmly.
- When the computer, and speed/cadence are dirty, wash them with water or wipe them with a soft cloth dampened with diluted neutral detergent, then wipe with dry cloth. Do not use solvents such as benzene or rubbing alcohol as they may damage the surfaces.

# Spare accessories

## Standard accessories

#160-2380  
Parts kit

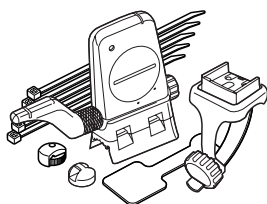

#160-2385  
Speed sensor kit

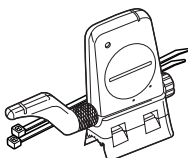

#160-0280  
Bracket band



#160-2193  
Bracket

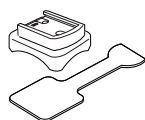

#169-9691  
Wheel magnet



#169-9766  
Cadence magnet



#166-5150  
Lithium battery (CR2032)





# Specifications

<b>Display functions</b>	Upper display	Current speed	0.0 (4.0) – 150.0 km/h [0.0 (3.0) – 93.0 mph] For 27-inch tire size
		Average speed	0.0 - 150.0 km/h [0.0 - 93.0 mph]
		Maximum speed	0.0 (4.0) – 150.0 km/h [0.0 (3.0) – 93.0 mph]
	Middle display	Cadence	0 (20) – 199 rpm
		Average cadence	0 – 199 rpm
		Maximum cadence	0 (20) – 199 rpm
	Lower display	Date	'07.01.01 – '99.12.31 (Display format can be switched)
		Clock	0:00'00" – 23:59'59" [AM 1:00'00" – PM 12:59'59"] (Both 12 and 24-hour modes can be selected)
		Total time	0 – 99999 hour
		Odometer	0.0 – 9999.9/10000 – 999999 km [mile]
		Elapsed time	00'00"0 – 59'59"9 / 01:00'00" – 99:59'59"
		Trip distance	0.00 – 9999.99 km [mile]
		Countdown distance	9999.90 – 0.00 km [mile]
		Lap number	L-01 – L-99
Average lap speed in real time		0.0 – 150.0 km/h [0.0 – 93.0 mph]	
Lap timer		00'00"0 – 59'59"9 / 01:00'00" – 99:59'59"	
Trip lap distance in real time	0.00 – 9999.99 km [mile]		
Lap	Upper display (average lap speed, maximum lap speed) Middle display (average lap cadence, Lap number, maximum lap cadence) Lower display (trip lap distance, lap time, split time)		
<b>Control system</b>	4-bit one-chip microcomputer, crystal oscillator		
<b>Display system</b>	Liquid crystal display (EL backlight)		
<b>Speed/Cadence sensor signal detection system</b>	Noncontact magnetic sensor		
<b>Sensor signal transmission and reception</b>	2.4 GHz ISM Band		
<b>Communication range</b>	5 m (above 5 m, transmission distance may vary due to environmental conditions)		
<b>Operating temperature range</b>	32 °F – 104 °F [0 °C – 40 °C] (This product will not function appropriately when exceeding the Working Temperature range. Slow response or black LCD at lower or higher temperature may happen respectively.)		
<b>Storage temperature range</b>	-4 °F – 122 °F [-20 °C – 50 °C]		
<b>Wheel circumference set range</b>	0100 – 3999 mm		
<b>Power supply/battery life</b>	Computer	: CR2032 x 1 / Approx. 1 years (When using 1 hour/day)	
	Speed sensor	: CR2032 x 1 / Approx. 1 years (When using 1 hour/day)	
<b>Dimensions/Weight</b>	Computer	: 2-7/32" x 1-1/2" x 11/16" (56.0 x 38.0 x 17.3 mm) / 0.98 oz (28 g) (With the batteries)	
	Speed sensor	: 2-9/16" x 3-9/16" x 9/16" (65.0 x 90.5 x 14.4 mm) / 1.25 oz (36 g) (With the batteries)	

\* When the elapsed time exceeds 100 hours, or the trip distance exceeds 9999.99 km/h, "E" appears in place of the average speed.

\* Designs and specifications are subject to change without notice, due to modifications or improvements.

## Registration

### **CATEYE Web Site (<http://www.cateye.com>)**

For warranty service you must confirm your product. Please confirm your V2c as soon as possible. CATEYE provides you technical support and new product information as much as possible.

Please confirm on-line through our web site, or send the registration card below directly to our Customer Service Department. For registration, please fill in the product's serial number (the 7-digits number marked on on the battery cover of computer).

--	--	--	--	--	--	--

## Limited warranty

### **2-Year: computer, and speed sensor**

**(Not including depletion of batteries)**

CatEye products are warranted to be free of defects from materials and workmanship for a period of two years from original purchase. If the product fails to work due to normal use, CatEye will repair or replace the defect at no charge. Service must be performed by CatEye or an authorized retailer.

To return the product, pack it carefully and enclose the warranty certificate (proof or purchase) with instruction for repair. Please write or type your name and address clearly on the warranty certificate.

Insurance, handling and transportation charges to CatEye shall be borne by person desiring service.

For UK and REPUBLIC OF IRELAND consumers, please return to the place of purchase. This does not affect your statutory rights.

### **CAT EYE CO., LTD.**

#### **Service & Research Address for USA:**

#### **CATEYE Service and Research Center**

1705 14th St. 115 Boulder, CO 80302

Phone: 303.443.4595

Fax: 303.473.0006

Toll Free: 800.5CATEYE

E-mail: [service@cateye.com](mailto:service@cateye.com)

URL: <http://www.cateye.com>

#### **Japan Office:**

2-8-25, Kuwazu, Higashi Sumiyoshi-ku, Osaka 546-0041 Japan

Attn: CATEYE Customer Service Section