

# TEST REPORT

of

## FCC Part 15 Subpart C AND CANADA RSS-210

New Application;  Class I PC;  Class II PC

**Product :** Remote control switch  
**Brand:** CAT EYE  
**Model:** WSW-001  
**Model Difference:** N/A  
**FCC ID:** ON5-WSW001  
**IC:** 5672A-WSW001  
**FCC Rule Part:** §15.249, Cat:DXX  
**IC Rule Part:** RSS 210 Issue 8, Dec. 2010, Annex 2.9  
**Applicant:** CAT EYE CO.,LTD.  
**Address:** 2-8-25 KUWAZU,  
HIGASHI-SUMIYOSHI-KU,OSAKA, JAPAN

### Test Performed by:

#### International Standards Laboratory

<Lung-Tan LAB>

\*Site Registration No.

BSMI: SL2-IN-E-0013; MRA TW1036; TAF: 0997; IC: IC4067B-3;

\*Address:

No. 120, Lane 180, Hsin Ho Rd.

Lung-Tan Dist., Tao Yuan City 325, Taiwan

\*Tel : 886-3-407-1718; Fax: 886-3-407-1738

Report No.: **ISL-15LR099FCDXX**

Issue Date : **2015/06/09**



Test results given in this report apply only to the specific sample(s) tested and are traceable to national or international standard through calibration of the equipment and evaluating measurement uncertainty herein.

This report MUST not be used to claim product endorsement by TAF, NVLAP or any agency of the Government.

This test report shall not be reproduced except in full, without the written approval of International Standards Laboratory.

## VERIFICATION OF COMPLIANCE

**Applicant:** CAT EYE CO.,LTD.  
**Product Description:** Remote control switch  
**Brand Name:** CAT EYE  
**Model No.:** WSW-001  
**Model Difference:** N/A  
**FCC ID:** ON5-WSW001  
**IC:** 5672A-WSW001  
**FCC Rule Part:** §15.249, Cat:DXX  
**IC Rule Part:** RSS 210 Issue 8, Dec. 2010, Annex 2.9  
**Date of test:** 2014/11/13 ~ 2015/06/03  
**Date of EUT Received:** 2014/11/03

### We hereby certify that:

All the tests in this report have been performed and recorded in accordance with the standards described above and performed by an independent electromagnetic compatibility consultant, International Standards Laboratory.

The test results contained in this report accurately represent the measurements of the characteristics and the energy generated by sample equipment under test at the time of the test. The sample equipment tested as described in this report is in compliance with the limits of above standards.

<b>Test By:</b>	 _____	<b>Date:</b>	2015/06/09 _____
	<i>Dion Chang / Engineer</i>		
<b>Prepared By:</b>	 _____	<b>Date:</b>	2015/06/09 _____
	<i>Gigi Yeh / Specialist</i>		
<b>Approved By:</b>	 _____	<b>Date:</b>	2015/06/09 _____
	<i>Vincent Su / Technical Manager</i>		

## Version

Version No.	Date	Description
00	2015/06/09	Initial creation of document

## Table of Contents

<b>1.</b>	<b>GENERAL INFORMATION .....</b>	<b>5</b>
1.1.	PRODUCT DESCRIPTION .....	5
1.2.	RELATED SUBMITTAL(S) / GRANT (S) .....	6
1.3.	TEST METHODOLOGY.....	6
1.4.	TEST FACILITY .....	6
1.5.	SPECIAL ACCESSORIES.....	6
1.6.	EQUIPMENT MODIFICATIONS .....	6
<b>2.</b>	<b>SYSTEM TEST CONFIGURATION .....</b>	<b>7</b>
2.1.	EUT CONFIGURATION.....	7
2.2.	EUT EXERCISE .....	7
2.3.	TEST PROCEDURE.....	7
2.4.	LIMITATION .....	8
2.5.	CONFIGURATION OF TESTED SYSTEM.....	10
<b>3.</b>	<b>SUMMARY OF TEST RESULTS .....</b>	<b>11</b>
<b>4.</b>	<b>CONDUCTED EMISSIONS TEST .....</b>	<b>12</b>
4.1	MEASUREMENT PROCEDURE: .....	12
4.2	TEST SET-UP (BLOCK DIAGRAM OF CONFIGURATION) .....	12
4.3	MEASUREMENT EQUIPMENT USED: .....	12
4.4	MEASUREMENT RESULT: .....	12
<b>5.</b>	<b>RADIATED EMISSION TEST (TX,RX) .....</b>	<b>15</b>
5.1	MEASUREMENT PROCEDURE.....	15
5.2	TEST SET-UP (BLOCK DIAGRAM OF CONFIGURATION) .....	15
5.3	MEASUREMENT EQUIPMENT USED: .....	16
5.4	FIELD STRENGTH CALCULATION .....	17
5.5	MEASUREMENT RESULT .....	18
<b>6.</b>	<b>20 DB BAND WIDTH MEASUREMENT.....</b>	<b>25</b>
6.1	MEASUREMENT PROCEDURE.....	26
6.2	TEST SET-UP (BLOCK DIAGRAM OF CONFIGURATION) .....	26
6.3	MEASUREMENT EQUIPMENT USED: .....	26
6.4	MEASUREMENT RESULTS:.....	26
<b>7.</b>	<b>99% BAND WIDTH MEASUREMENT .....</b>	<b>29</b>
7.1	MEASUREMENT PROCEDURE.....	29
7.2	TEST SET-UP (BLOCK DIAGRAM OF CONFIGURATION) .....	29
7.3	MEASUREMENT EQUIPMENT USED: .....	29
7.4	MEASUREMENT RESULTS:.....	29

## 1. General Information

### 1.1. Product Description

General:

Product Name	Remote control switch	
Brand Name	CAT EYE	
Model Name	WSW-001	
Model Difference	N/A	
Hardware Version:	N/A	
Software Version	N/A	
Adhoc Mode	No	
DFS Mode	N/A	
TPC	No	
Operation Environment	Outdoor used	
Product SW/HW version	HW: TX_WT-8383RF_SOP16 v4; SW: MA380Y-3	
Radio SW/HW version	HW: TX_WT-8383RF_SOP16 v4; SW: MA380Y-3	
Test SW Version	MA380Y-3-RFTEST	
RF power setting in TEST SW	N/A	
Power Supply	Tx : 3Vdc from Battery(CR1632) Rx : 14.4V from Battery(BA-608)	
	Adapter : Yes (for Rx)	Mode : SPBC1603A

2.4G:

Modulation type	FSK
Frequency Range(MHz)	2408-2474MHz
Channel Number	34
Measured Power	83.46dBuV/m at 3 m
Antenna Designation:	Printing ANTENNA 2.4G Antenna : -1.55dBi (Max)

The report applies for 2.4GHz mode.

**Remark:** The above DUT's information was declared by manufacturer. Please refer to the specifications or user's manual for more detailed description.

**1.2. Related Submittal(s) / Grant (s)**

This submittal(s) (test report) is intended for **FCC ID: ON5-WSW001** filing to comply with Section 15.249 of the FCC Part 15, Subpart C Rules and **IC: 5672A-WSW001** filing to comply with Industry Canada RSS-210 issue 8:2010 Annex 2.9.

**1.3. Test Methodology**

Both conducted and radiated testing were performed according to the procedures in ANSI C63.4 ( 2014) and RSS-Gen: 2014. Radiated testing was performed at an antenna to EUT distance 3 meters.

**1.4. Test Facility**

The measurement facilities used to collect the 3m Radiated Emission and AC power line conducted data are located on the address of **International Standards Laboratory** <Lung-Tan LAB> No. 120, Lane 180, Hsin Ho Rd., Lung-Tan Dist., Tao Yuan City 325, Taiwan which are constructed and calibrated to meet the FCC requirements in documents ANSI C63.4: 2014. FCC Registration Number is: TW1036, Canada Registration Number: 4067B-3.

**1.5. Special Accessories**

Not available for this EUT intended for grant.

**1.6. Equipment Modifications**

Not available for this EUT intended for grant.

## **2. System Test Configuration**

### **2.1. EUT Configuration**

The EUT configuration for testing is installed on RF field strength measurement to meet the Commissions requirement and operating in a manner which intends to maximize its emission characteristics in a continuous normal application.

### **2.2. EUT Exercise**

The Transmitter was operated in the engineering operating mode. the Tx frequency was fixed at Lowest, Mid and highest channel which were for the purpose of the measurements.

### **2.3. Test Procedure**

#### **2.3.1 Conducted Emissions**

The EUT is a placed on as turn table which is 0.8 m above ground plane. According to the requirements in Section 7 and 13 of ANSI C63.4- 2014, ANSI C63.10: 2013 and RSS-Gen: 2014. Conducted emissions from the EUT measured in the frequency range between 0.15 MHz and 30MHz using CISPR Quasi-Peak and Average detector mode.

#### **2.3.2 Radiated Emissions**

The EUT is a placed on as turn table which is 0.8 m above ground plane. The turn table shall rotate 360 degrees to determine the position of maximum emission level. EUT is set 3m away from the receiving antenna which varied from 1m to 4m to find out the highest emission. And also, each emission was to be maximized by changing the polarization of receiving antenna both horizontal and vertical. In order to find out the max. emission, the relative positions of this hand-held transmitter(EUT) was rotated through three orthogonal axes according to the requirements in Section 8 and 13 of ANSI C63.4- 2014, ANSI C63.10: 2013and RSS-Gen:2014.

## 2.4. Limitation

### (1) Conducted Emission

According to section 15.207(a) and RSS-Gen §8.8 Conducted Emission Limits is as following.

Frequency (MHz)	Conducted Limit (dBuV)	
	Quasi-Peak	Average
0.15 – 0.5	66 - 56	56 - 46
0.5 – 5	56	46
5 - 30	60	50

### (2) Radiated Emission 15.249(a) and RSS-210 issue 8,§A2.9(a)

The field strength of emissions from intentional radiators operated within these frequency bands shall comply with the following.

Frequency (MHz)	Field strength of Fundamental	Field strength of Harmonics	Distance (m)
902 - 928	50 mV/m (94dBuV/m)	500 uV/m (54dBuV/m)	3
2400 – 2483.5	50 mV/m (94dBuV/m)	500 uV/m (54dBuV/m)	3
5725 – 5875	50 mV/m (94dBuV/m)	500 uV/m (54dBuV/m)	3



**(3) Radiated Emission 15.249 (d) and RSS-210 issue 8, §A2.9(b)**

Emission Radiated outside of the specified frequency bands, except for harmonics, shall be attenuated by at least 50dB below the level of the fundamental or to the general radiated emission limits in Section 15.209 and RSS-210 issue 8, §A2.9(a) as below, whichever is the lesser attenuation.

Frequency (MHz)	Field strength $\mu\text{V/m}$	Distance (m)	Field strength at 3m $\text{dB}\mu\text{V/m}$
1.705-30	30	30	69.54
30-88	100	3	40
88-216	150	3	43.5
216-960	200	3	46
Above 960	500	3	54

**(4) Radiated Emission 15.249(e) and RSS-210 issue 8**

For frequencies above 1000MHz, the above field strength limits are based on average limits. The peak field strength of any emission shall not exceed the maximum permitted average limits specified above by more than 20dB under any condition of modulation.

- Remark:
1. Emission level in  $\text{dB}\mu\text{V/m} = 20 \log (\mu\text{V/m})$
  2. Measurement was performed at an antenna to the closed point of EUT distance of meters.
  3. Only spurious frequency is permitted to locate within the Restricted Bands specified in provision of § 15.205
  4. Emission spurious frequency which appearing within the Restricted Bands specified in provision of § 15.205, then the general radiated emission limits in § 15.209 apply.

## 2.5. Configuration of Tested System

Fig. 2-1 Configuration of Tested System

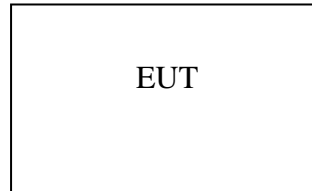

Table 2-2 Equipment Used in Tested System

Item	Equipment	Mfr/Brand	Model/ Type No.	Series No.	Data Cable	Power Cord
1	--					

**Note:** All the above equipment/cables were placed in worse case positions to maximize emission signals during emission test.

**Grounding:** Grounding was in accordance with the manufacturer's requirements and conditions for the intended use.

### 3. Summary of Test Results

FCC Rules	Description Of Test	Result
§15.207/ RSS-Gen §8.8	Conducted Emission	Compliant
§15.249(a)(d)(e) RSS-210 issue 8, §A2.9(a)(b)	Field Strength Measurement (TX)	Compliant
§15.215(c)	20dB band width Measurement	Compliant
RSS-Gen §6.6	99% Power Bandwidth	Compliant

#### Description of test modes

The EUT has been tested under operating condition.

Test program used to control the EUT for staying in continuous transmitting and receive mode is programmed.

Channel low (2408MHz), mid (2440MHz) and high (2474MHz) with highest data rate are chosen for full testing.

## 4. Conducted Emissions Test

### 4.1 Measurement Procedure:

1. The EUT was placed on a table which is 0.8m above ground plane.
2. Maximum procedure was performed on the six highest emissions to ensure EUT compliance.
3. Repeat above procedures until all frequency measured were complete.

### 4.2 Test SET-UP (Block Diagram of Configuration)

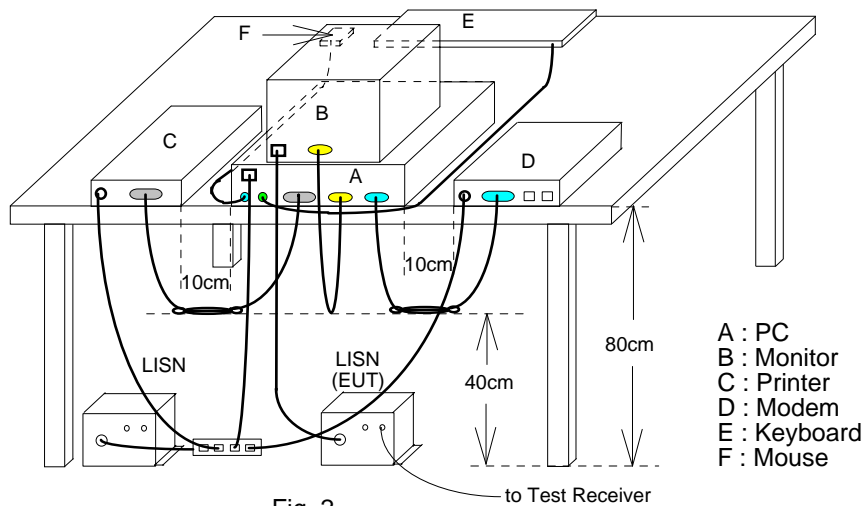

### 4.3 Measurement Equipment Used:

Conducted Emission Test Site					
EQUIPMENT TYPE	MFR	MODEL NUMBER	SERIAL NUMBER	LAST CAL.	CAL DUE.
Conduction 04-3 Cable	WOKEN	CFD 300-NL	Conduction 04 -3	07/24/2014	07/23/2015
EMI Receiver 17	Rohde & Schwarz	ESCI 7	100887	09/03/2014	09/02/2015
LISN 18	ROHDE & SCHWARZ	ENV216	101424	02/11/2015	02/10/2016
LISN 19	ROHDE & SCHWARZ	ENV216	101425	03/12/2015	03/11/2016

### 4.4 Measurement Result:

Note: Refer to next page for measurement data and plots.

### AC POWER LINE CONDUCTED EMISSION TEST DATA

Operation Mode:	Operation Mode	Test Date:	2015/05/14
Test By:	Dino		



No.	Frequency (MHz)	QP_R (dBuV)	AVG_R (dBuV)	Correct Factor (dB)	QP Emission (dBuV)	QP Limit (dBuV)	QP Margin (dB)	AVG Emission (dBuV)	AVG Limit (dBuV)	AVG Margin (dB)
1	0.150	33.60	6.70	9.65	43.25	65.99	-22.74	16.35	55.99	-39.64
2	0.170	35.82	18.60	9.65	45.47	64.96	-19.49	28.25	54.96	-26.71
3	0.190	35.67	21.26	9.65	45.32	64.04	-18.72	30.91	54.04	-23.13
4	0.234	29.48	17.07	9.65	39.13	62.31	-23.18	26.72	52.31	-25.59
5	0.258	31.61	16.66	9.66	41.27	61.50	-20.23	26.32	51.50	-25.18
6	4.570	22.00	12.80	9.81	31.81	56.00	-24.19	22.61	46.00	-23.39
7	19.042	23.48	16.90	10.05	33.53	60.00	-26.47	26.95	50.00	-23.05



Address: No. 120, Lane 180, Hsin Ho Rd., Lung-Tan Dist.,  
 Tao Yuan City 325, Taiwan.  
 Tel: 03-4071718

**Conducted Emission Measurement**

operator: Mark Chan  
 Temperature: 25 °C  
 Humidity: 60 %

Date: 2015/5/4

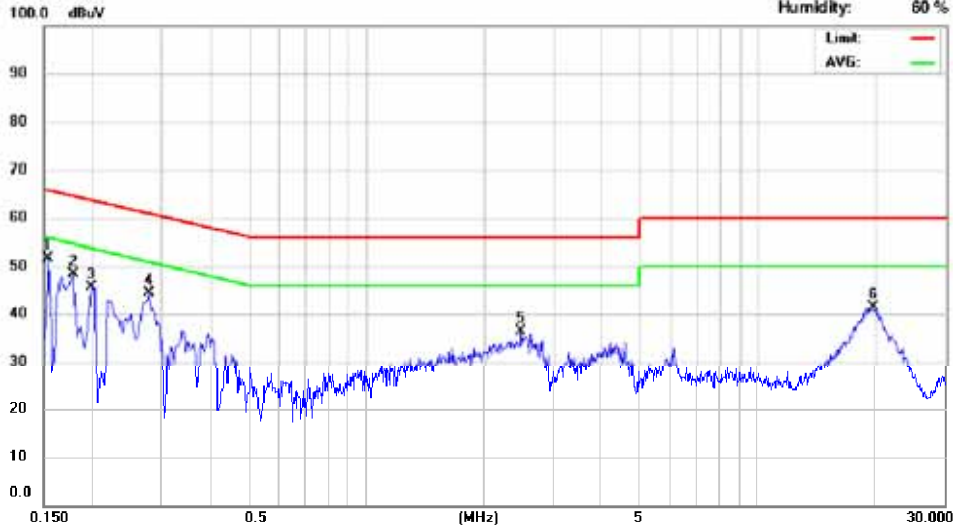

Site: Conduction 03

Phase: *N*

Limit: CISPR22 Class B Conduction

No.	Frequency (MHz)	QP_R (dBuV)	AVG_R (dBuV)	Correct Factor (dB)	QP Emission (dBuV)	QP Limit (dBuV)	QP Margin (dB)	AVG Emission (dBuV)	AVG Limit (dBuV)	AVG Margin (dB)
1	0.154	33.09	8.30	9.65	42.74	65.78	-23.04	17.95	55.78	-37.83
2	0.178	33.16	17.37	9.65	42.81	64.58	-21.77	27.02	54.58	-27.56
3	0.198	27.08	2.01	9.65	36.73	63.69	-26.96	11.66	53.69	-42.03
4	0.278	30.76	19.79	9.66	40.42	60.88	-20.46	29.45	50.88	-21.43
5	2.474	21.00	12.68	9.76	30.76	56.00	-25.24	22.44	46.00	-23.56
6	19.586	26.79	20.91	10.08	36.87	60.00	-23.13	30.99	50.00	-19.01

## 5. Radiated Emission Test (TX)

### 5.1 Measurement Procedure

1. The EUT was placed on a turntable that is 0.8m above ground plane.
2. Maximum procedure was performed on the six highest emissions to ensure EUT compliance.
3. And also, each emission was to be maximized by changing the polarization of receiving antenna both horizontal and vertical.
4. Repeat above procedures until all frequency measured were complete.

### 5.2 Test SET-UP (Block Diagram of Configuration)

(A) Radiated Emission Test Set-Up, Frequency Below 1000MHz

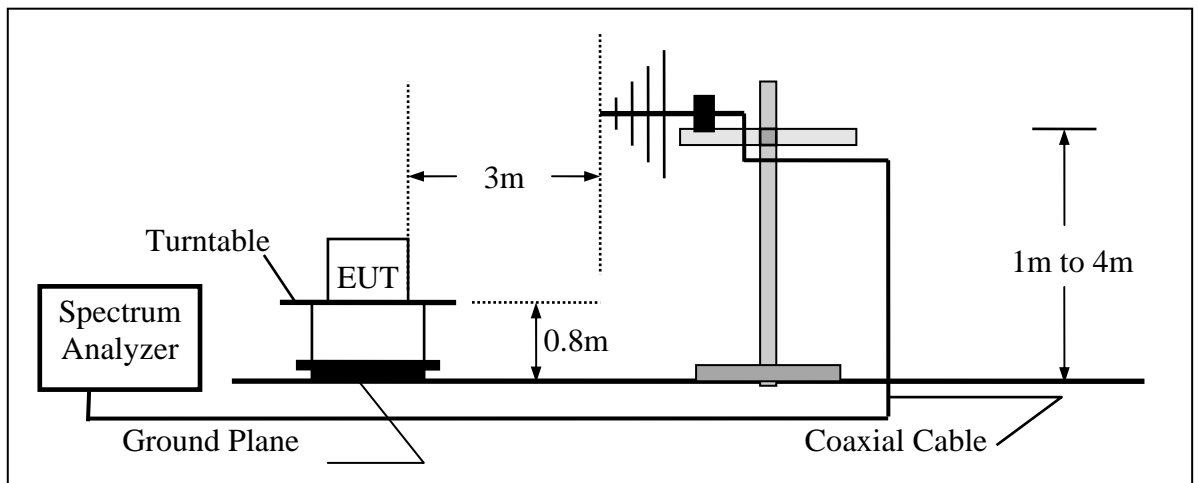

(B) Radiated Emission Test Set-UP Frequency Over 1 GHz

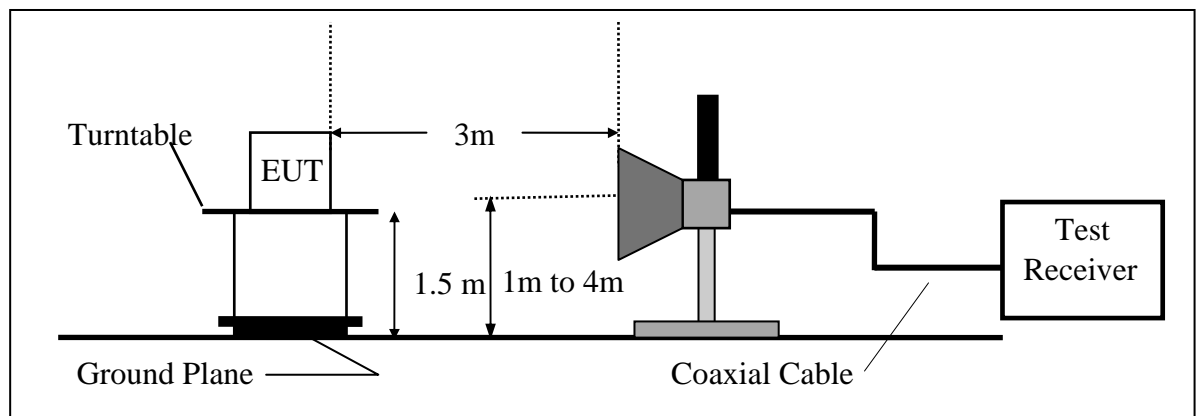

**5.3 Measurement Equipment Used:**

Chamber 14(966)					
EQUIPMENT TYPE	MFR	MODEL NUMBER	SERIAL NUMBER	LAST CAL.	CAL DUE.
Spectrum Analyzer 21(26.5GHz)	Agilent	N9010A	MY49060537	07/29/2015	07/28/2016
Spectrum Analyzer 20(6.5GHz)	Agilent	E4443A	MY48250315	05/26/2014	05/25/2015
Spectrum Analyzer 22(43GHz)	R&S	FSU43	100143	05/07/2015	05/06/2016
Dipole antenna	SCHWARZBECK	VHAP,30-300	919	12/03/2013	12/02/2015
Dipole antenna	SCHWARZBECK	UHAP,300-1000	1195	12/03/2013	12/02/2015
Loop Antenna9K-30M	A.H.SYSTEM	SAS-564	294	03/07/2015	03/06/2017
Bilog Antenna30-1G	Schaffner	CBL 6112B	2756	12/30/2014	12/29/2015
Horn antenna1-18G	ETS	3117	00066665	11/27/2014	11/26/2015
Horn antenna26-40G(05)	Com-power	AH-640	100A	01/21/2015	01/20/2017
Horn antenna18-26G(04)	Com-power	AH-826	081001	05/15/2015	05/14/2017
Preamplifier9-1000M	HP	8447D	NA	03/12/2015	03/11/2016
Preamplifier1-18G	MITEQ	AFS44-00101800-25-10P-44	1329256	07/30/2014	07/29/2015
Preamplifier1-26G	EM	EM01M26G	NA	03/11/2015	03/10/2016
Preamplifier26-40G	MITEQ	JS-26004000-27-5A	818471	05/08/2015	05/07/2017
Cable1-18G	HUBER SUHNER	Sucoflex 106	NA	12/02/2014	12/01/2015
Cable UP to 1G	HUBER SUHNER	RG 214/U	NA	10/17/2014	10/16/2015
SUCOFLEX 1GHz~40GHz cable	HUBER SUHNER	Sucoflex 102	27963/2&37421/2	10/03/2013	10/02/2015
Signal Generator	R&S	SMU200A	102330	03/11/2015	02/10/2016
Signal Generator	Anritsu	MG3692A	20311	10/29/2014	10/28/2015
2.4G Filter	Micro-Tronics	Brm50702	76	12/27/2014	12/26/2015



#### 5.4 Field Strength Calculation

The field strength is calculated by adding the Antenna Factor and Cable Factor and subtracting the Amplifier Gain and Duty Cycle Correction Factor(if any) from the measured reading. The basic equation with a sample calculation is as follows:

$$FS = RA + AF + CL - AG$$

Where	FS = Field Strength	CL = Cable Attenuation Factor (Cable Loss)
	RA = Reading Amplitude	AG = Amplifier Gain
	AF = Antenna Factor	

## 5.5 Measurement Result

### 5.5.1 Fundamental Emission Measurement Result

Test Date : 2015/05/26  
Temp : 25

Test By : Dino  
Hum. : 60%

CH Low:

No	Freq MHz	Reading dBuV	Factor dB	Level dBuV/m	Limit dBuV/m	Over Limit dB	Remark	Pol V/H
1	2408.47	88.34	-10.62	77.72	114.00	-36.28	Peak	VERTICAL
1	2408.57	94.08	-10.62	83.46	114.00	-30.54	Peak	HORIZONTAL

CH Mid:

No	Freq MHz	Reading dBuV	Factor dB	Level dBuV/m	Limit dBuV/m	Over Limit dB	Remark	Pol V/H
1	2439.52	87.33	-10.51	76.82	114.00	-37.18	Peak	VERTICAL
1	2439.56	93.49	-10.51	82.98	114.00	-31.02	Peak	HORIZONTAL

CH High:

No	Freq MHz	Reading dBuV	Factor dB	Level dBuV/m	Limit dBuV/m	Over Limit dB	Remark	Pol V/H
1	2473.52	84.76	-10.38	74.38	114.00	-39.62	Peak	VERTICAL
1	2473.48	91.46	-10.38	81.08	114.00	-32.92	Peak	HORIZONTAL

Remark:

- 1 Measuring frequencies from the lowest internal frequency to the 10th of fundamental frequency
- 2 Field strength limits for frequency above 1000MHz are based on average limits.  
However, Peak mode field strength shall not exceed the average limits specified plus 20dB.
- 3 Measurement of data within this frequency range shown “ - ” in the table above means the reading of emissions are attenuated more than 20dB below the permissible limits or the field strength is too small to be measured.
- 4 Spectrum Peak mode IF bandwidth Setting : 1GHz- 26GHz, RBW= 1MHz, Sweep time= 200 ms., the VBW setting was 3 MHz.
- 5 Spectrum AV mode IF bandwidth Setting : 1GHz- 26GHz, RBW= 1MHz, Sweep time= 200 ms., the VBW setting was 10MHz.

### 5.5.2 Radiated Spurious Emission Measurement Result (below 1GHz)

Operation Mode	TX CH Low	Test Date	2015/05/26
Fundamental Frequency	2408 MHz	Test By	Dino
Temperature	25	Humidity	60 %

No	Freq MHz	Reading dBuV	Factor dB	Level dBuV/m	Limit dBuV/m	Over Limit dB	Remark	Pol V/H
1	71.71	33.03	-15.03	18.00	40.00	-22.00	Peak	VERTICAL
2	89.17	39.55	-18.64	20.91	43.50	-22.59	Peak	VERTICAL
3	106.63	34.77	-16.47	18.30	43.50	-25.20	Peak	VERTICAL
4	358.83	25.86	-9.94	15.92	46.00	-30.08	Peak	VERTICAL
5	548.95	26.03	-6.63	19.40	46.00	-26.60	Peak	VERTICAL
6	789.51	25.11	-2.34	22.77	46.00	-23.23	Peak	VERTICAL
1	71.71	34.80	-15.03	19.77	40.00	-20.23	Peak	HORIZONTAL
2	89.17	39.55	-18.64	20.91	43.50	-22.59	Peak	HORIZONTAL
3	163.86	25.02	-12.26	12.76	43.50	-30.74	Peak	HORIZONTAL
4	249.22	25.36	-12.91	12.45	46.00	-33.55	Peak	HORIZONTAL
5	454.86	25.68	-7.74	17.94	46.00	-28.06	Peak	HORIZONTAL
6	767.20	25.54	-2.66	22.88	46.00	-23.12	Peak	HORIZONTAL

Remark:

- 1 Measuring frequencies from the lowest internal frequency to the 10th of fundamental frequency
- 2 Field strength limits for frequency above 1000MHz are based on average limits. However, Peak mode field strength shall not exceed the average limits specified plus 20dB.
- 3 “F” denotes fundamental frequency; “H” denotes harmonics frequency. “S” denotes spurious frequency.
- 4 Measurement of data within this frequency range shown “ - ” in the table above means the reading of emissions are attenuated more than 20dB below the permissible limits or the field strength is too small to be measured.
- 5 Spectrum Peak mode IF bandwidth Setting : 1GHz- 26GHz, RBW= 1MHz, Sweep time= 200 ms., the VBW setting was 3 MHz.
- 6 Spectrum AV mode if bandwidth Setting : 1GHz- 26GHz, RBW= 1MHz, VBW= 10Hz, Sweep time= 200 ms.

**Radiated Spurious Emission Measurement Result (below 1GHz)**

Operation Mode	TX CH Mid	Test Date	2015/05/26
Fundamental Frequency	2440 MHz	Test By	Dino
Temperature	25	Humidity	60 %

No	Freq MHz	Reading dBuV	Factor dB	Level dBuV/m	Limit dBuV/m	Over Limit dB	Remark	Pol V/H
1	71.71	32.24	-15.03	17.21	40.00	-22.79	Peak	VERTICAL
2	89.17	39.94	-18.64	21.30	43.50	-22.20	Peak	VERTICAL
3	106.63	35.77	-16.47	19.30	43.50	-24.20	Peak	VERTICAL
4	166.77	25.08	-12.43	12.65	43.50	-30.85	Peak	VERTICAL
5	399.57	25.71	-9.19	16.52	46.00	-29.48	Peak	VERTICAL
6	776.90	26.27	-2.52	23.75	46.00	-22.25	Peak	VERTICAL
1	41.64	32.41	-12.34	20.07	40.00	-19.93	Peak	HORIZONTAL
2	71.71	34.88	-15.03	19.85	40.00	-20.15	Peak	HORIZONTAL
3	89.17	39.12	-18.64	20.48	43.50	-23.02	Peak	HORIZONTAL
4	151.25	25.21	-12.11	13.10	43.50	-30.40	Peak	HORIZONTAL
5	461.65	26.57	-7.71	18.86	46.00	-27.14	Peak	HORIZONTAL
6	853.53	26.10	-1.38	24.72	46.00	-21.28	Peak	HORIZONTAL

Remark:

- 1 Measuring frequencies from the lowest internal frequency to the 10th of fundamental frequency
- 2 Field strength limits for frequency above 1000MHz are based on average limits. However, Peak mode field strength shall not exceed the average limits specified plus 20dB.
- 3 “F” denotes fundamental frequency; “H” denotes harmonics frequency. “S” denotes spurious frequency.
- 4 Measurement of data within this frequency range shown “ - ” in the table above means the reading of emissions are attenuated more than 20dB below the permissible limits or the field strength is too small to be measured.
- 5 Spectrum Peak mode IF bandwidth Setting : 1GHz- 26GHz, RBW= 1MHz, Sweep time= 200 ms., the VBW setting was 3 MHz.
- 6 Spectrum AV mode if bandwidth Setting : 1GHz- 26GHz, RBW= 1MHz, VBW= 10Hz, Sweep time= 200 ms.

**Radiated Spurious Emission Measurement Result (below 1GHz)**

Operation Mode	TX CH High	Test Date	2015/05/26
Fundamental Frequency	2474 MHz	Test By	Dino
Temperature	25	Humidity	60 %

No	Freq MHz	Reading dBuV	Factor dB	Level dBuV/m	Limit dBuV/m	Over Limit dB	Remark	Pol V/H
1	69.77	34.22	-14.60	19.62	40.00	-20.38	Peak	VERTICAL
2	89.17	40.69	-18.64	22.05	43.50	-21.45	Peak	VERTICAL
3	106.63	34.83	-16.47	18.36	43.50	-25.14	Peak	VERTICAL
4	159.01	24.51	-12.07	12.44	43.50	-31.06	Peak	VERTICAL
5	541.19	25.73	-6.76	18.97	46.00	-27.03	Peak	VERTICAL
6	751.68	25.93	-2.88	23.05	46.00	-22.95	Peak	VERTICAL
1	32.91	32.71	-13.12	19.59	40.00	-20.41	Peak	HORIZONTAL
2	72.68	35.10	-15.26	19.84	40.00	-20.16	Peak	HORIZONTAL
3	89.17	39.12	-18.64	20.48	43.50	-23.02	Peak	HORIZONTAL
4	149.31	25.13	-12.17	12.96	43.50	-30.54	Peak	HORIZONTAL
5	485.90	25.71	-7.54	18.17	46.00	-27.83	Peak	HORIZONTAL
6	778.84	24.90	-2.50	22.40	46.00	-23.60	Peak	HORIZONTAL

Remark:

- 1 Measuring frequencies from the lowest internal frequency to the 10th of fundamental frequency
- 2 Field strength limits for frequency above 1000MHz are based on average limits. However, Peak mode field strength shall not exceed the average limits specified plus 20dB.
- 3 “F” denotes fundamental frequency; “H” denotes harmonics frequency. “S” denotes spurious frequency.
- 4 Measurement of data within this frequency range shown “ - ” in the table above means the reading of emissions are attenuated more than 20dB below the permissible limits or the field strength is too small to be measured.
- 5 Spectrum Peak mode IF bandwidth Setting : 1GHz- 26GHz, RBW= 1MHz, Sweep time= 200 ms., the VBW setting was 3 MHz.
- 6 Spectrum AV mode if bandwidth Setting : 1GHz- 26GHz, RBW= 1MHz, VBW= 10Hz, Sweep time= 200 ms.

**Radiated Spurious Emission Measurement Result (above 1GHz)**

Operation Mode : TX CH Low Test Date : 2015/05/26  
 Fundamental Frequency : 2408 MHz Test By : Dino  
 Temp : 25 Hum. : 60%

No	Freq MHz	Reading dBuV	Factor dB	Level dBuV/m	Limit dBuV/m	Over Limit dB	Remark	Pol V/H
1	4816.00	49.48	-3.15	46.33	74.00	-27.67	Peak	VERTICAL
2	7224.00	---					Peak	VERTICAL
3	7258.00	44.25	4.31	48.56	74.00	-25.44	Peak	VERTICAL
4	9632.00	---					Peak	VERTICAL
5	12040.00	---					Peak	VERTICAL
1	4816.00	49.91	-3.15	46.76	74.00	-27.24	Peak	HORIZONTAL
2	7224.00	---						HORIZONTAL
3	7573.00	44.22	5.17	49.39	74.00	-24.61	Peak	HORIZONTAL
4	9632.00	---						HORIZONTAL
5	12040.00	---						HORIZONTAL

Remark:

- 1 Measuring frequencies from the lowest internal frequency to the 10th of fundamental frequency
- 2 Field strength limits for frequency above 1000MHz are based on average limits. However, Peak mode field strength shall not exceed the average limits specified plus 20dB.
- 3 Measurement of data within this frequency range shown “ - ” in the table above means the reading of emissions are attenuated more than 20dB below the permissible limits or the field strength is too small to be measured.
- 4 Spectrum Peak mode IF bandwidth Setting : 1GHz- 26GHz, RBW= 1MHz, Sweep time= 200 ms., the VBW setting was 3 MHz.
- 5 Spectrum AV mode IF bandwidth Setting : 1GHz- 26GHz, RBW= 1MHz, Sweep time= 200 ms., the VBW setting was 10MHz.

**Radiated Spurious Emission Measurement Result (above 1GHz)**

Operation Mode : TX CH Mid Test Date : 2015/05/26  
 Fundamental Frequency : 2440 MHz Test By : Dino  
 Temp : 25 Hum. : 60%

No	Freq MHz	Reading dBuV	Factor dB	Level dBuV/m	Limit dBuV/m	Over Limit dB	Remark	Pol V/H
1	4880.00	49.43	-3.02	46.41	74.00	-27.59	Peak	VERTICAL
2	7320.00	45.28	4.48	49.76	74.00	-24.24	Peak	VERTICAL
3	9760.00	---						VERTICAL
4	12200.00	---						VERTICAL
1	4880.00	49.65	-3.02	46.63	74.00	-27.37	Peak	HORIZONTAL
2	7320.00	47.78	4.48	52.26	74.00	-21.74	Peak	HORIZONTAL
3	9760.00	---						HORIZONTAL
4	12200.00	---						HORIZONTAL

Remark:

- 1 Measuring frequencies from the lowest internal frequency to the 10th of fundamental frequency
- 2 Field strength limits for frequency above 1000MHz are based on average limits. However, Peak mode field strength shall not exceed the average limits specified plus 20dB.
- 3 Measurement of data within this frequency range shown “ - ” in the table above means the reading of emissions are attenuated more than 20dB below the permissible limits or the field strength is too small to be measured.
- 4 Spectrum Peak mode IF bandwidth Setting : 1GHz- 26GHz, RBW= 1MHz, Sweep time= 200 ms., the VBW setting was 3 MHz.
- 5 Spectrum AV mode IF bandwidth Setting : 1GHz- 26GHz, RBW= 1MHz, Sweep time= 200 ms., the VBW setting was 10MHz.

**Radiated Spurious Emission Measurement Result (above 1GHz)**

Operation Mode : TX CH High Test Date : 2015/05/26  
 Fundamental Frequency : 2474 MHz Test By : Dino  
 Temp : 25 Hum. : 60%

No	Freq MHz	Reading dBuV	Factor dB	Level dBuV/m	Limit dBuV/m	Over Limit dB	Remark	Pol V/H
1	4948.00	50.27	-2.86	47.41	74.00	-26.59	Peak	VERTICAL
2	7422.00	45.85	4.75	50.60	74.00	-23.40	Peak	VERTICAL
3	9896.00	---						VERTICAL
4	12370.00	---						VERTICAL
1	4948.00	50.32	-2.86	47.46	74.00	-26.54	Peak	HORIZONTAL
2	7422.00	48.61	4.75	53.36	74.00	-20.64	Peak	HORIZONTAL
3	9896.00	---						HORIZONTAL
4	12370.00	---						HORIZONTAL

**Remark:**

- 1 Measuring frequencies from the lowest internal frequency to the 10th of fundamental frequency
- 2 Field strength limits for frequency above 1000MHz are based on average limits. However, Peak mode field strength shall not exceed the average limits specified plus 20dB.
- 3 Measurement of data within this frequency range shown “ - ” in the table above means the reading of emissions are attenuated more than 20dB below the permissible limits or the field strength is too small to be measured.
- 4 Spectrum Peak mode IF bandwidth Setting : 1GHz- 26GHz, RBW= 1MHz, Sweep time= 200 ms., the VBW setting was 3 MHz.
- 5 Spectrum AV mode IF bandwidth Setting : 1GHz- 26GHz, RBW= 1MHz, Sweep time= 200 ms., the VBW setting was 10MHz.



### Radiated Spurious Emission Measurement Result (Band Edge)

Operation Mode : Band Edge Test Date :2014/06/07  
Temp./Hum. : 25 / : 60% Test By : Dino

#### CH Low

No	Freq MHz	Reading dBuV	Factor dB	Level dBuV/m	Limit dBuV/m	Over Limit dB	Remark	Pol V/H
1	2395.80	59.76	-10.67	49.09	74.00	-24.91	Peak	VERTICAL
2	2400.00	52.68	-10.66	42.02	74.00	-31.98	Peak	VERTICAL
3	2407.60	84.98	-10.62	74.36	74.00	0.36	Peak	VERTICAL
1	2396.00	62.83	-10.67	52.16	74.00	-21.84	Peak	HORIZONTAL
2	2400.00	54.40	-10.66	43.74	74.00	-30.26	Peak	HORIZONTAL
3	2408.50	90.01	-10.62	79.39	74.00	5.39	Peak	HORIZONTAL

#### CH High

No	Freq MHz	Reading dBuV	Factor dB	Level dBuV/m	Limit dBuV/m	Over Limit dB	Remark	Pol V/H
1	2483.50	52.48	-10.34	42.14	74.00	-31.86	Peak	VERTICAL
1	2483.50	52.35	-10.34	42.01	74.00	-31.99	Peak	HORIZONTAL

#### Remark:

- 1 Measuring frequencies from the lowest internal frequency to the 10th of fundamental frequency
- 2 Field strength limits for frequency above 1000MHz are based on average limits. However, Peak mode field strength shall not exceed the average limits specified plus 20dB.
- 3 Measurement of data within this frequency range shown “ - ” in the table above means the reading of emissions are attenuated more than 20dB below the permissible limits or the field strength is too small to be measured.
- 4 Spectrum Peak mode IF bandwidth Setting : 1GHz- 26GHz, RBW= 1MHz, Sweep time= 200 ms., the VBW setting was 3 MHz.
- 5 Spectrum AV mode IF bandwidth Setting : 1GHz- 26GHz, RBW= 1MHz, Sweep time= 200 ms., the VBW setting was 10MHz.

## 6. 20 dB Band Width Measurement

### 6.1 Measurement Procedure

1. The EUT was placed on a turn table which is 1.5m above ground plane.
2. Set ETU normal operating mode.
3. Set SPA Center Frequency = fundamental frequency, RBW = 100kHz, VBW = 300kHz, Span = 5MHz.
4. Set SPA Max hold. Mark peak, -20dB.

### 6.2 Test SET-UP (Block Diagram of Configuration)

Same as 4.2 Radiated Emission Measurement.

### 6.3 Measurement Equipment Used:

Same as 4.2 Radiated Emission Measurement.

### 6.4 Measurement Results:

2408 Channel : 2.2300 MHz

2440 Channel : 2.2400 M Hz

2474 Channel : 2.2500 M Hz

Refer to attached data chart.

**20dB Band Width test Plot**  
**CH Low**

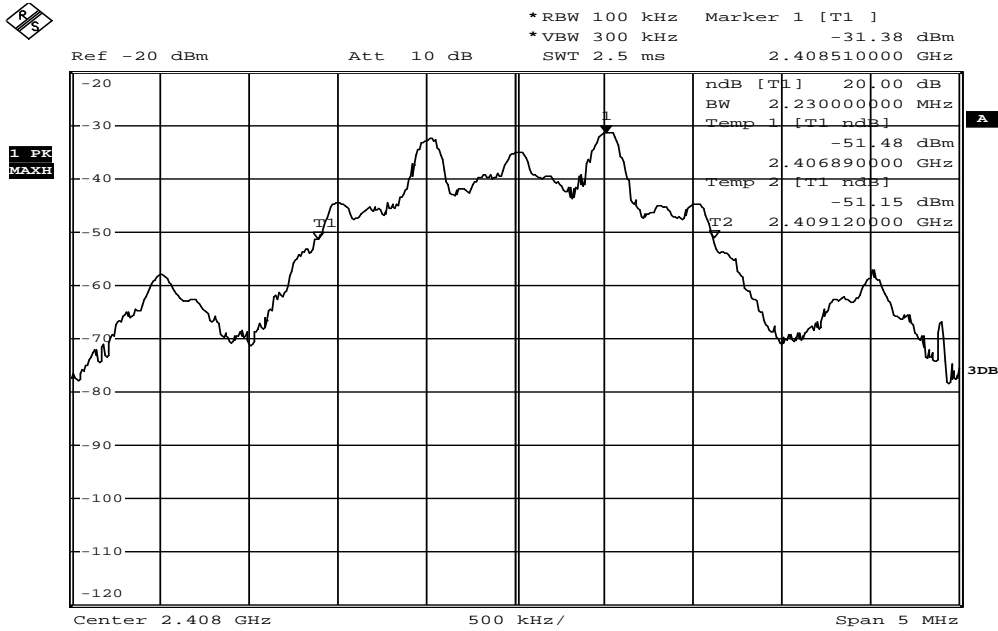

Date: 29.MAY.2015 15:26:44

**CH Mid**

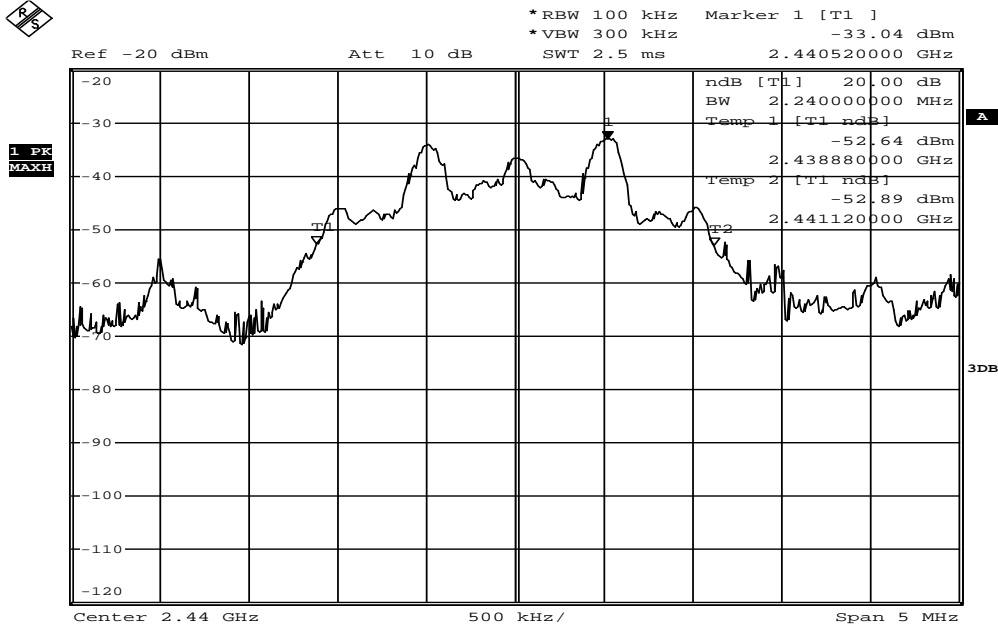

Date: 29.MAY.2015 15:26:59

CH High

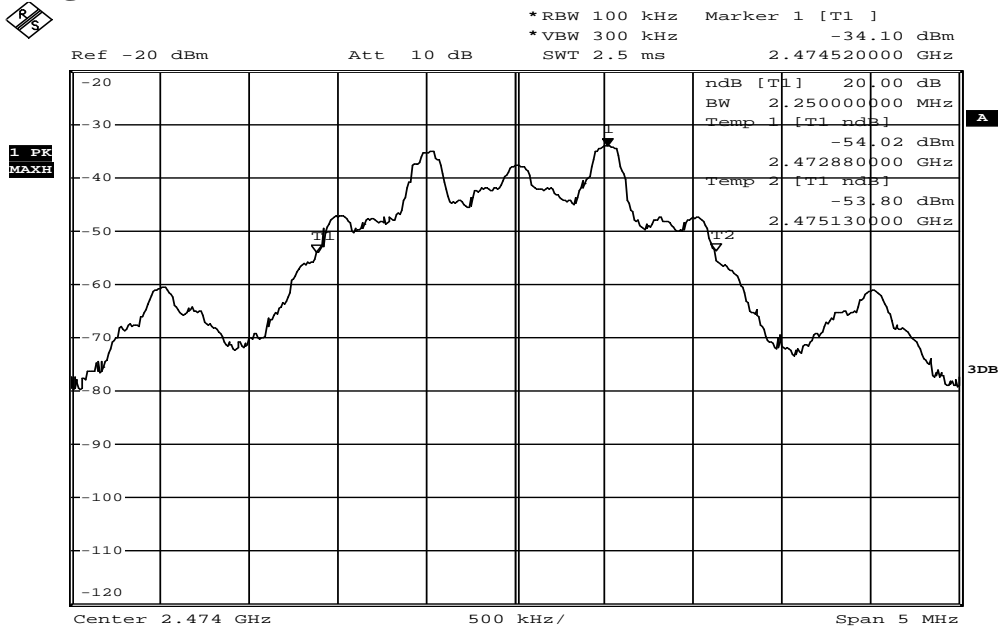

Date: 29.MAY.2015 15:26:13

## 7. 99% Band Width Measurement

### 7.1 Measurement Procedure

- 1 Place the EUT on the table and set it in transmitting mode.
- 2 Remove the antenna from the EUT and then connect a low loss RF cable from the antenna port to the spectrum analyzer.
- 3 Set the spectrum analyzer as RBW=1% of the approximate emission bandwidth, VBW = 3 times RBW, Span= approximately 20dB below the peak level. Sweep=auto
- 4 Turn on the 99% bandwidth function, max reading.
- 5 Repeat above procedures until all frequency measured were complete.

### 7.2 Test SET-UP (Block Diagram of Configuration)

Same as 4.2 Radiated Emission Measurement.

### 7.3 Measurement Equipment Used:

Same as 4.2 Radiated Emission Measurement.

### 7.4 Measurement Results:

2408 Channel : 2.1600 MHz

2440 Channel : 2.2500MHz

2474 Channel : 2.1500 MHz

Refer to attached data chart.

### 99% Band Width test Plot CH Low

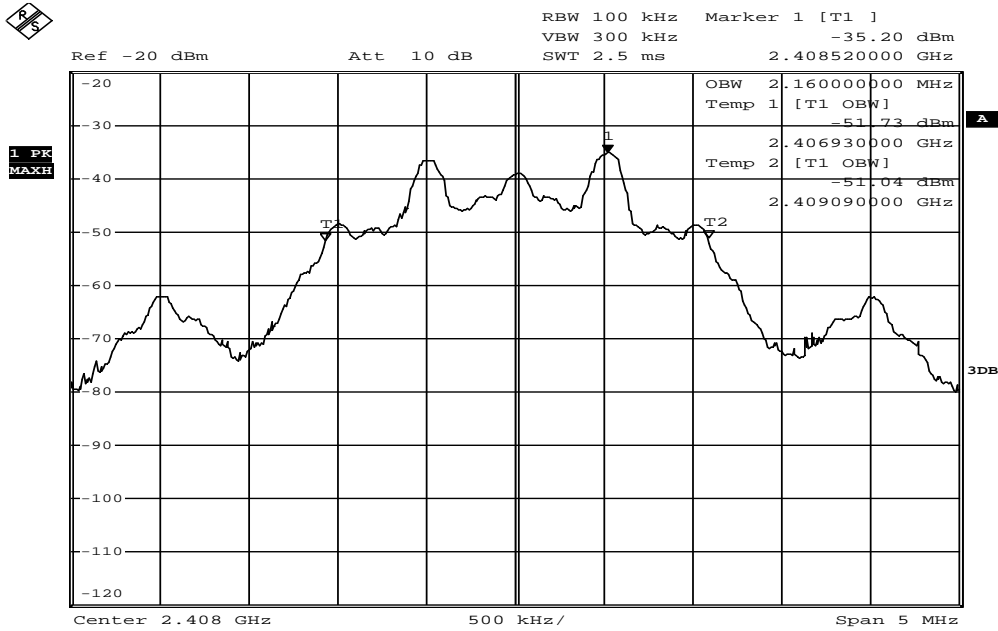

Date: 29.MAY.2015 15:35:18

### CH Mid

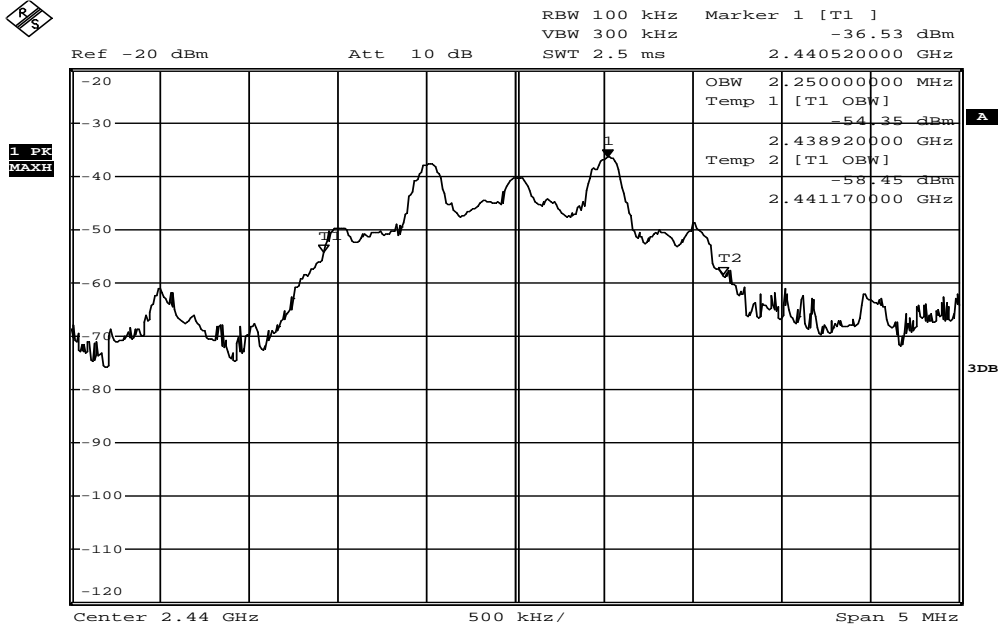

Date: 29.MAY.2015 15:35:33

CH High

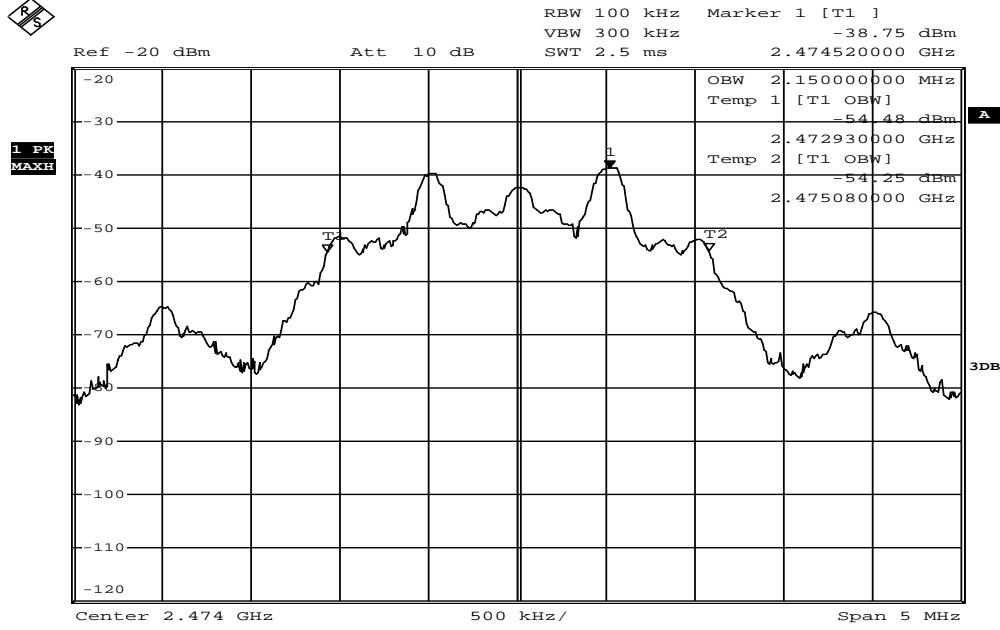

Date: 29.MAY.2015 15:35:48