

Bluetooth Antenna specification

Table

Parameter Specification	Parameter Specification
• Frequency Range	2400 MHz ~ 2483.5 MHz
• Brand name	Direction
• Model Name	CC_GPS100
• Antenna type	Monopole Antenna
• Maximum Antenna gain	-2.88 dBi

Antenna Performance Test

Trade Name	Direction									
Model Name	CC_GPS100									
Antenna type	Monopole Antenna									
Measurement / Position	3D Gain / Free Space									
Frequency (MHz)	2402	2412	2422	2432	2441	2442	2452	2462	2472	2480
Ant. Port Input Pwr. (dBm)	0.00	0.00	0.00	0.00	0.00	0.00	0.00	0.00	0.00	0.00
Tot. Rad. Pwr. (dBm)	-8.16	-8.38	-8.67	-8.83	-9.04	-8.94	-9.19	-9.34	-9.38	-9.48
Peak EIRP (dBm)	-2.88	-3.10	-3.22	-3.52	-3.69	-3.57	-4.15	-3.73	-4.00	-4.59
Directivity (dBi)	5.28	5.29	5.45	5.31	5.34	5.38	5.04	5.61	5.38	4.89
Efficiency (dB)	-8.16	-8.38	-8.67	-8.83	-9.04	-8.94	-9.19	-9.34	-9.38	-9.48
Efficiency (%)	15.29	14.52	13.59	13.11	12.48	12.76	12.04	11.64	11.55	11.27
Gain (dBi)	-2.88	-3.10	-3.22	-3.52	-3.69	-3.57	-4.15	-3.73	-4.00	-4.59

Appendix

2402MHz

Total

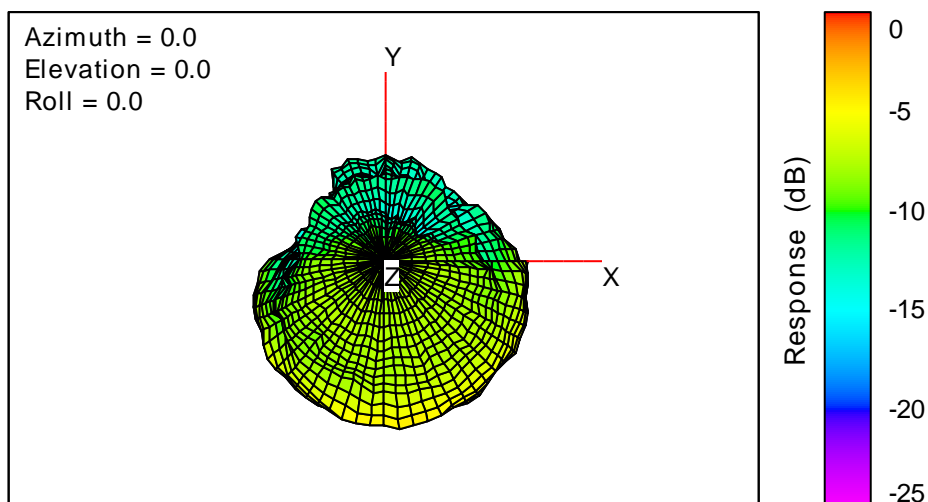

Total

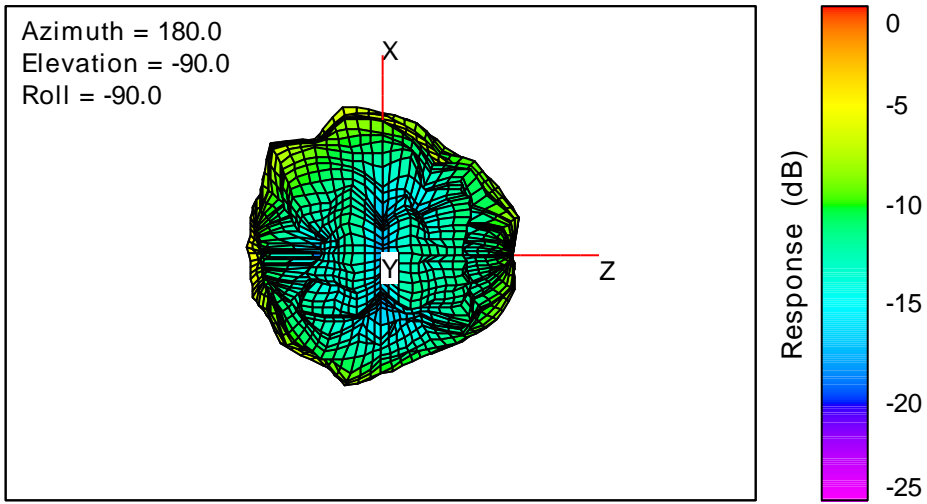

Total

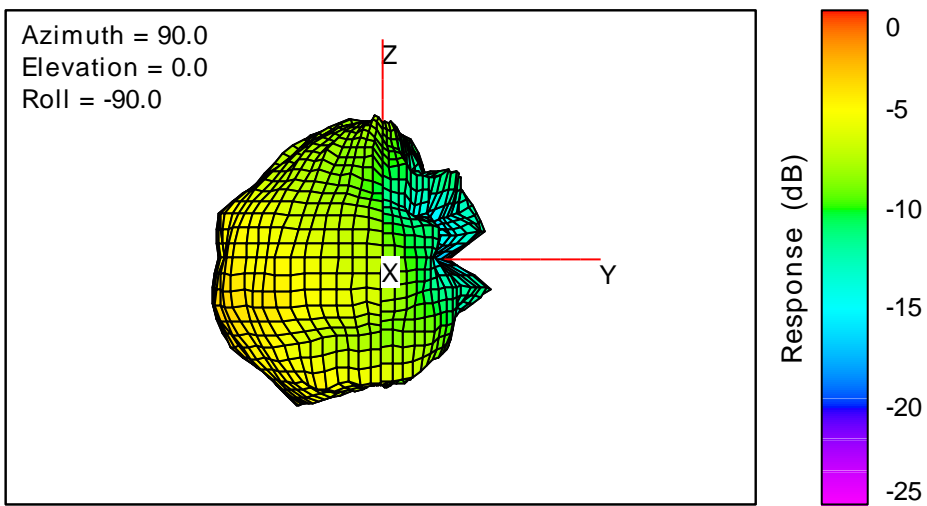

2412MHz

Total

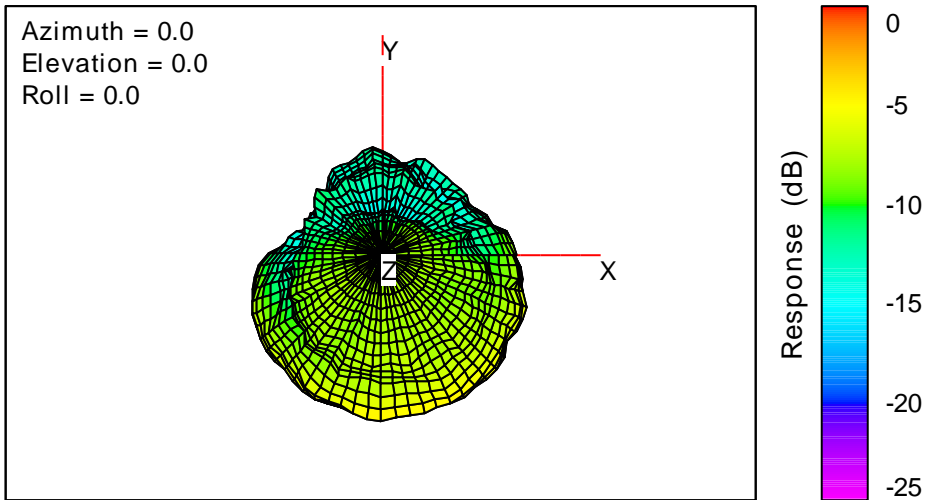

Total

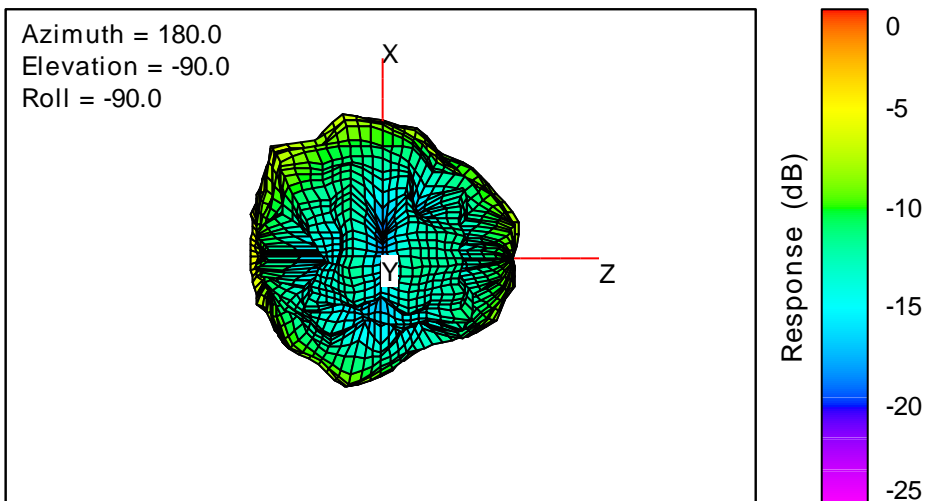

Total

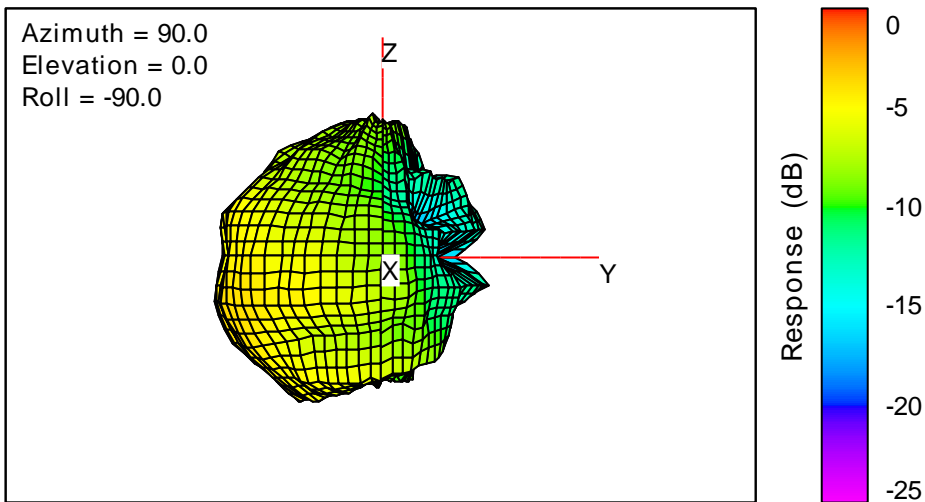

2422MHz

Total

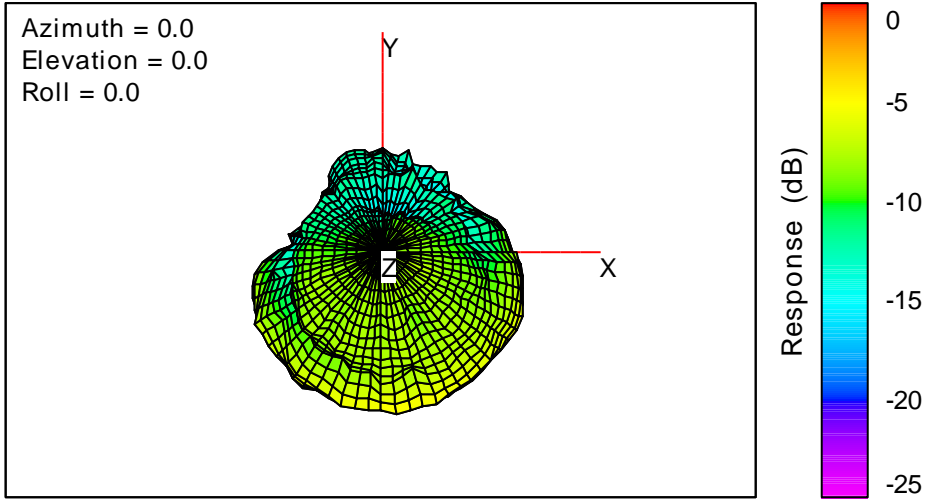

Total

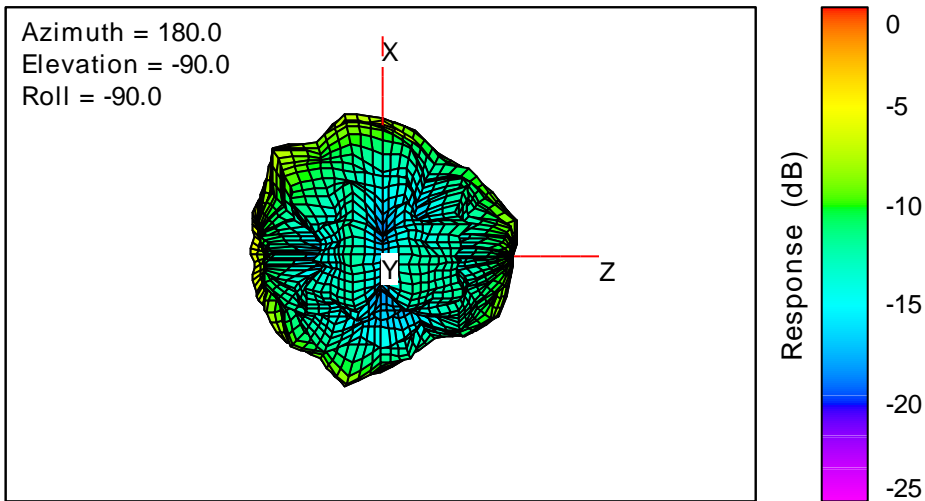

Total

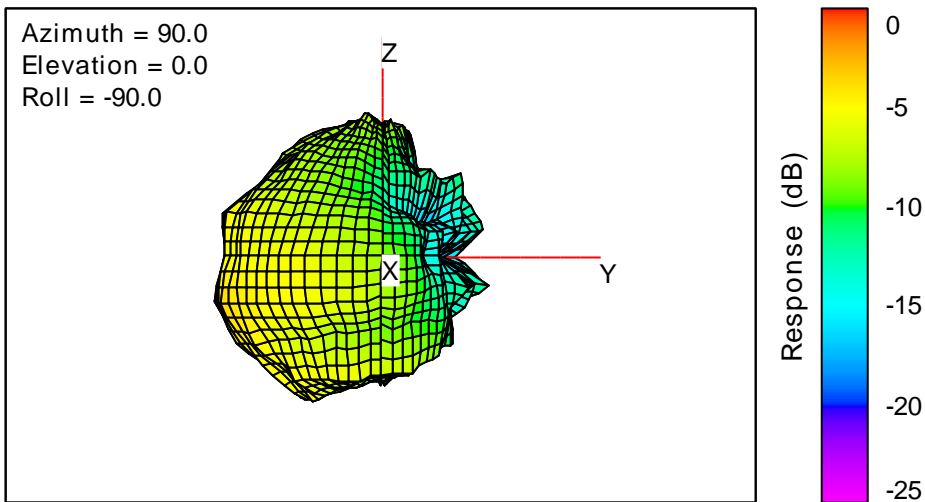

2432MHz

Total

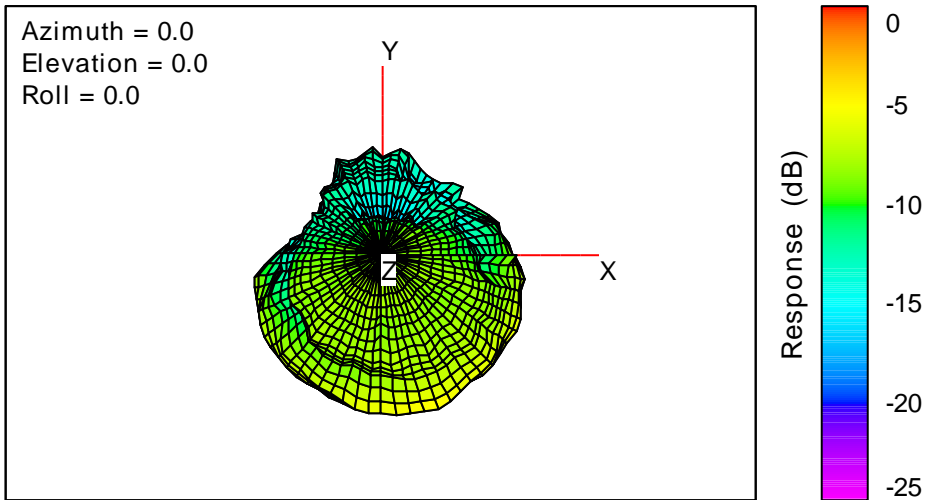

Total

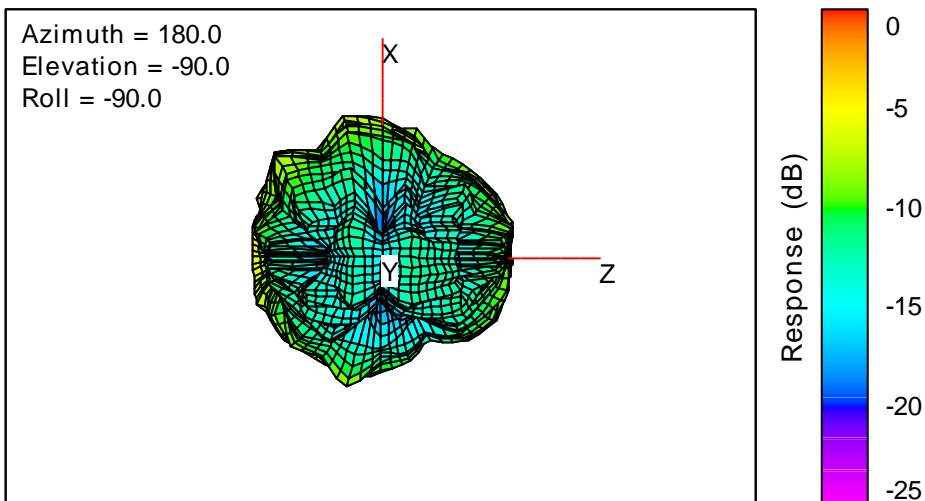

Total

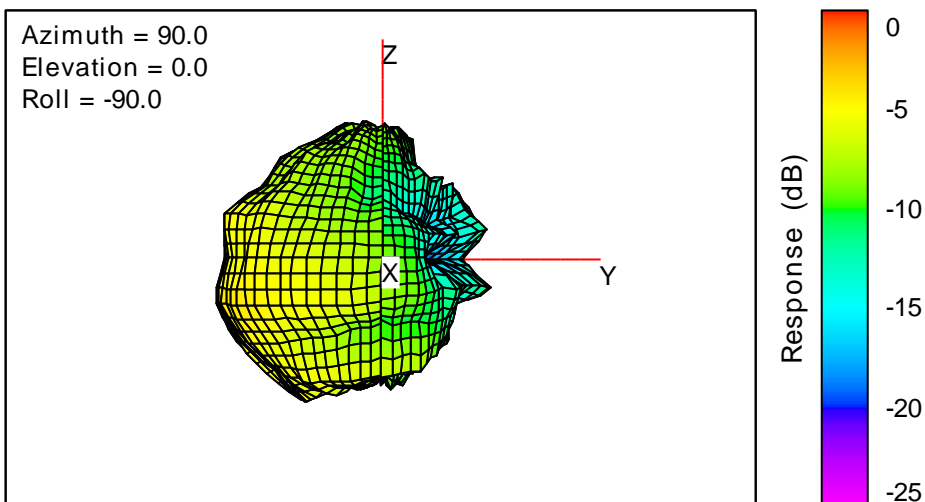

2441MHz

Total

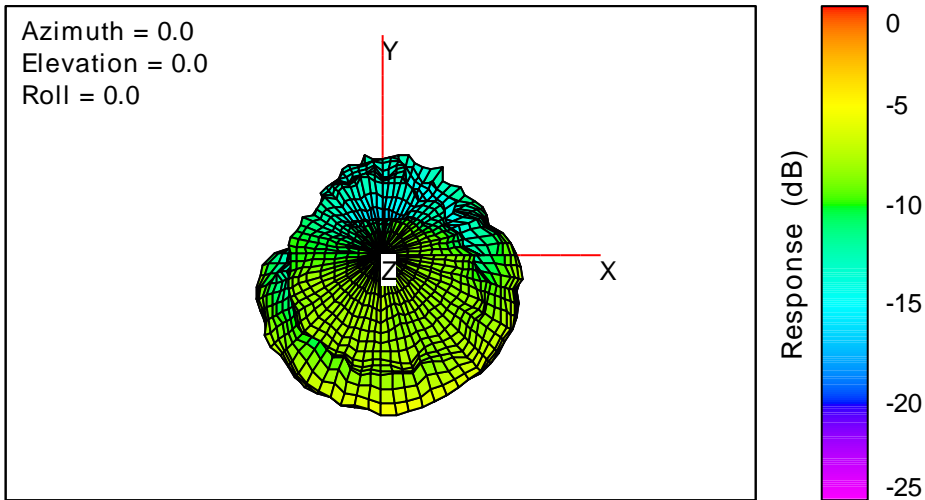

Total

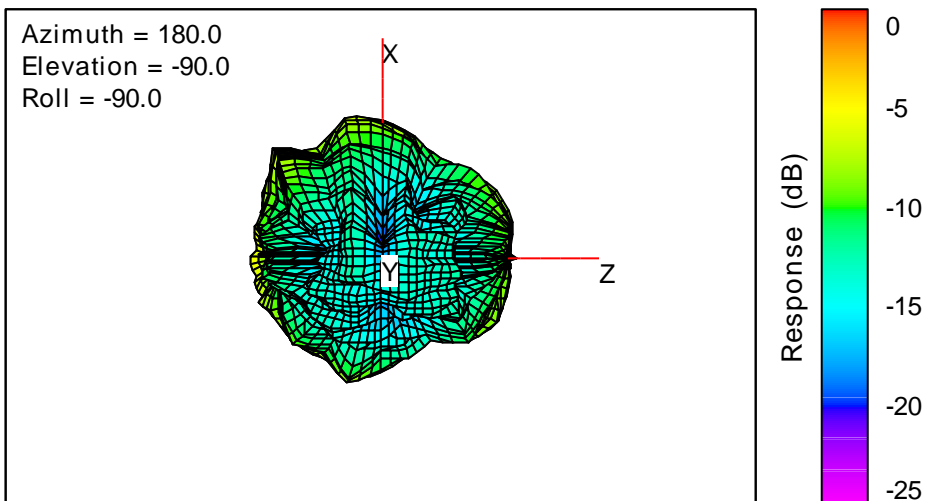

Total

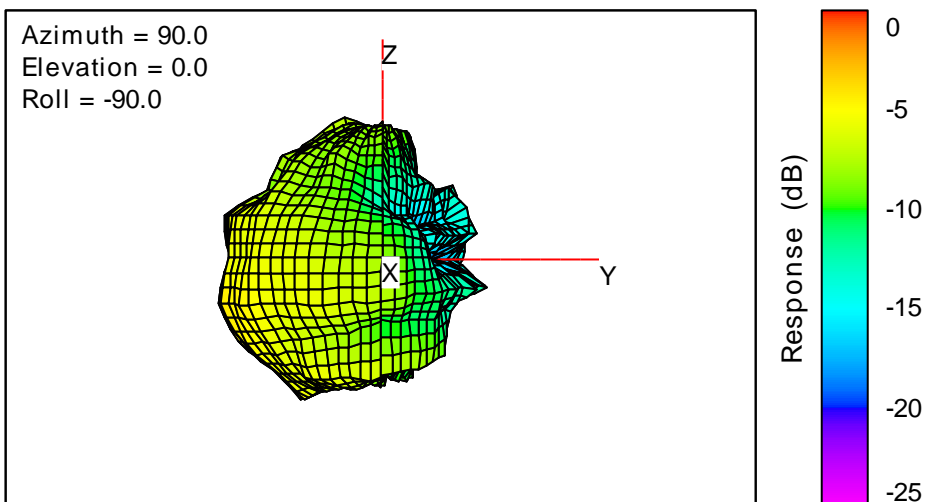

2442MHz

Total

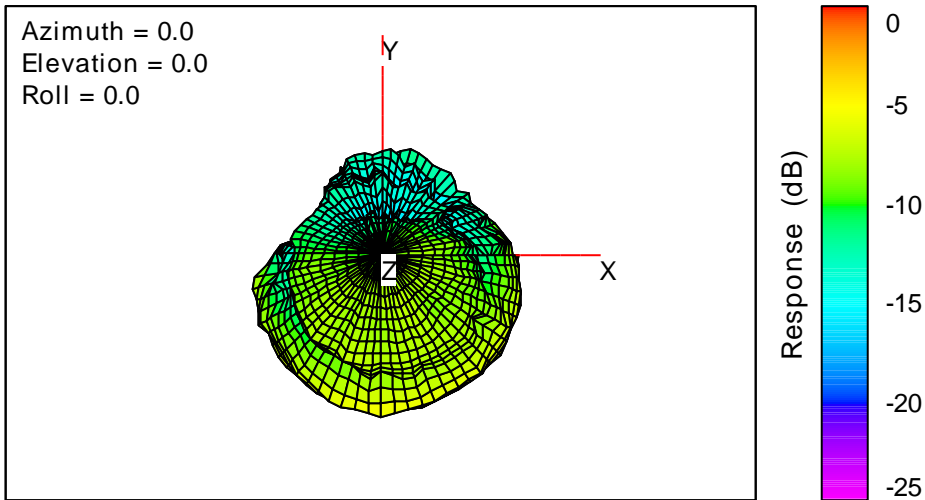

Total

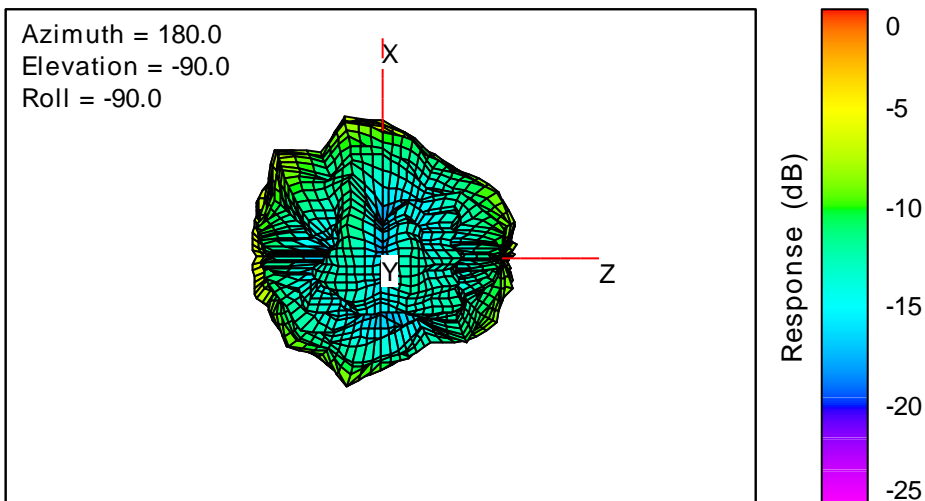

Total

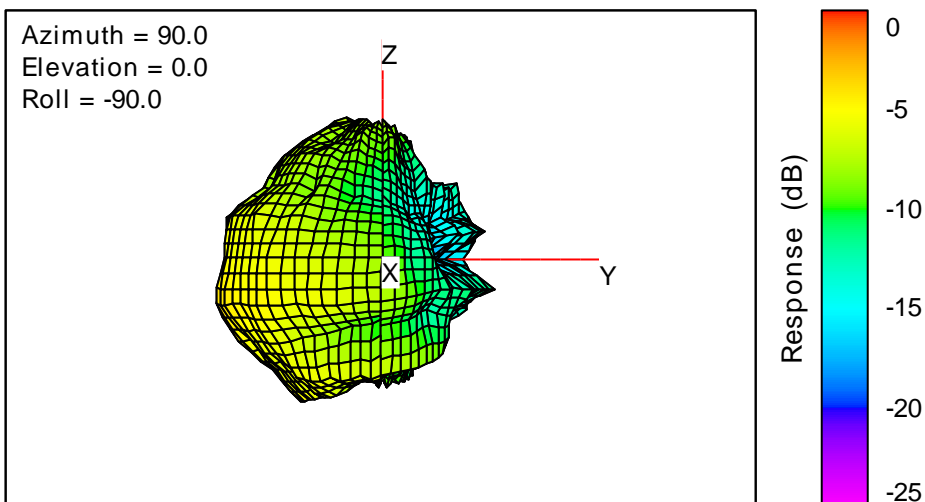

2452MHz

Total

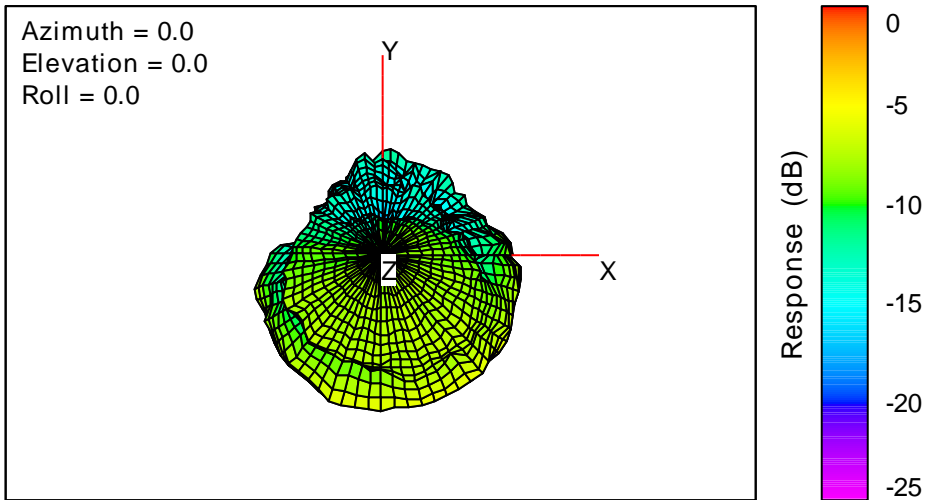

Total

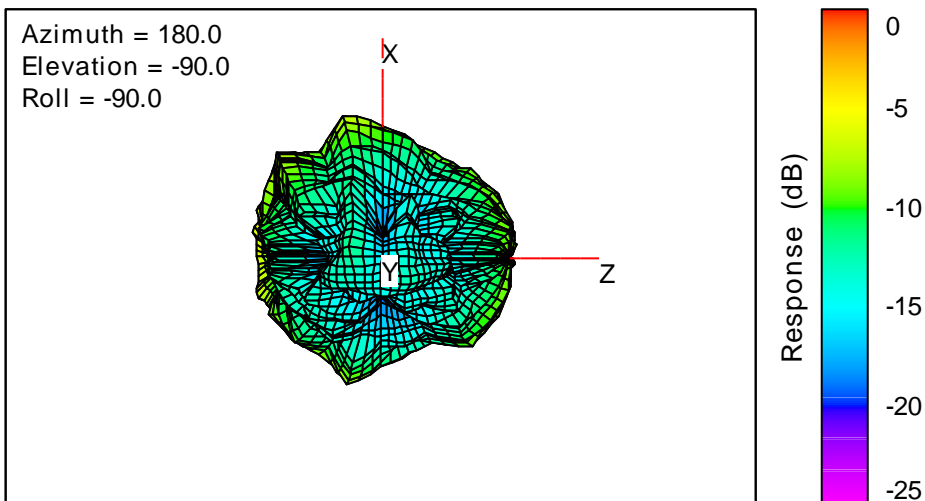

Total

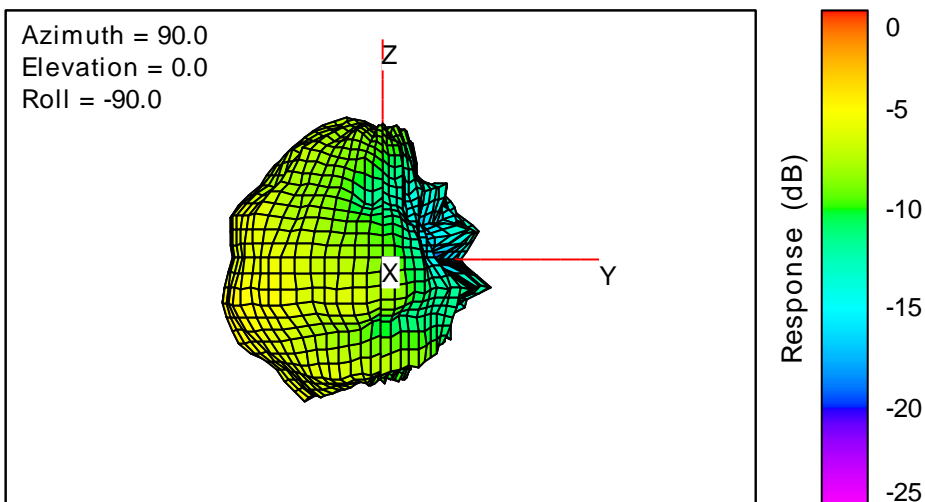

2462MHz

Total

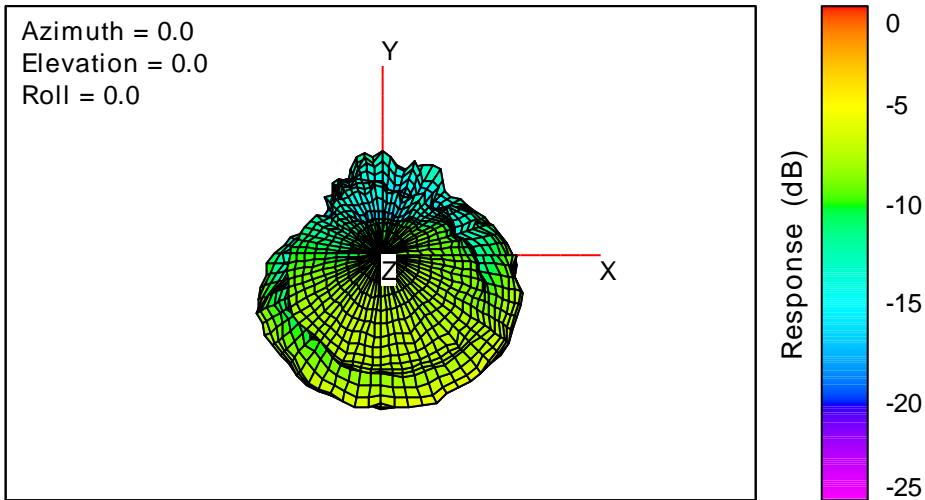

Total

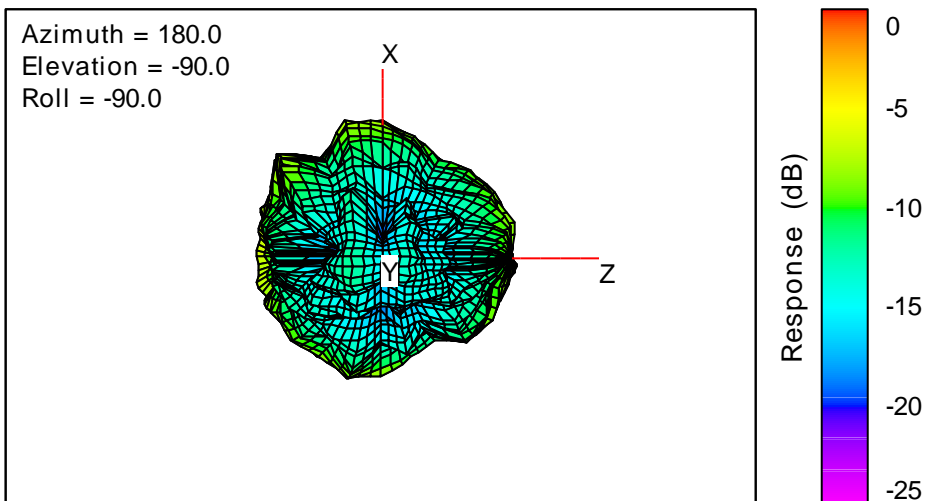

Total

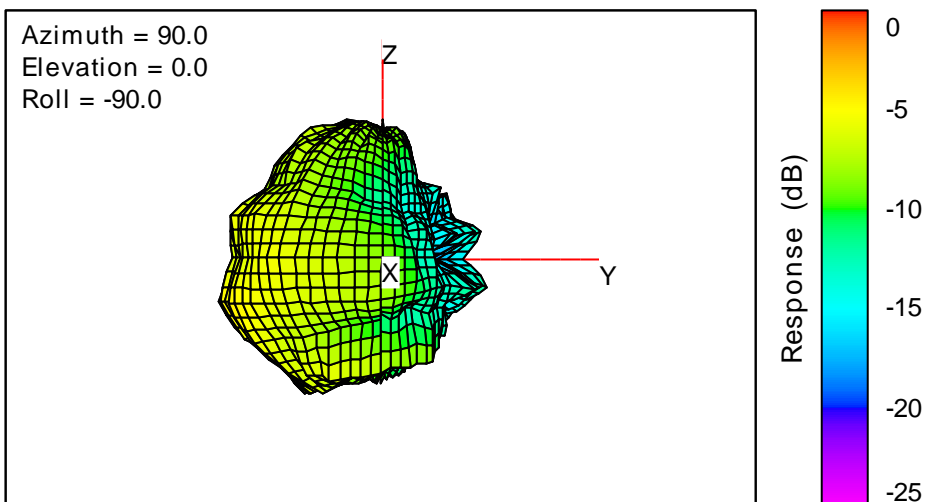

2472MHz

Total

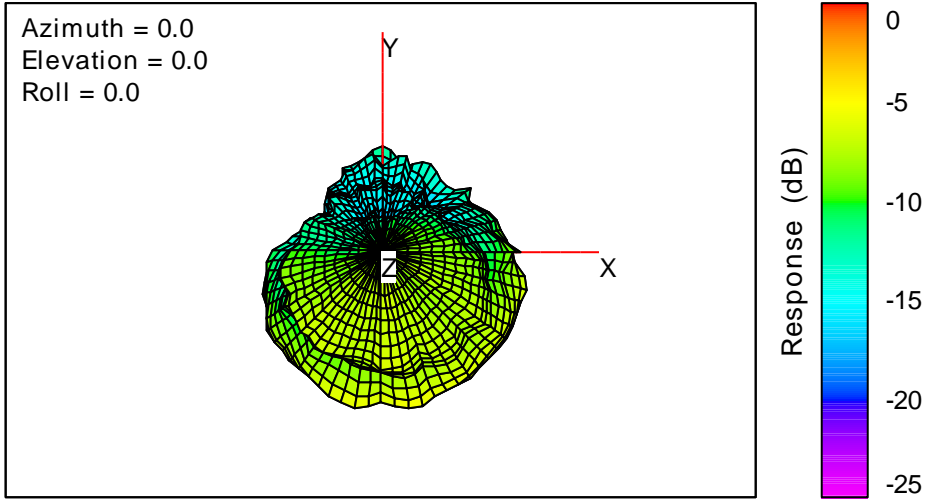

Total

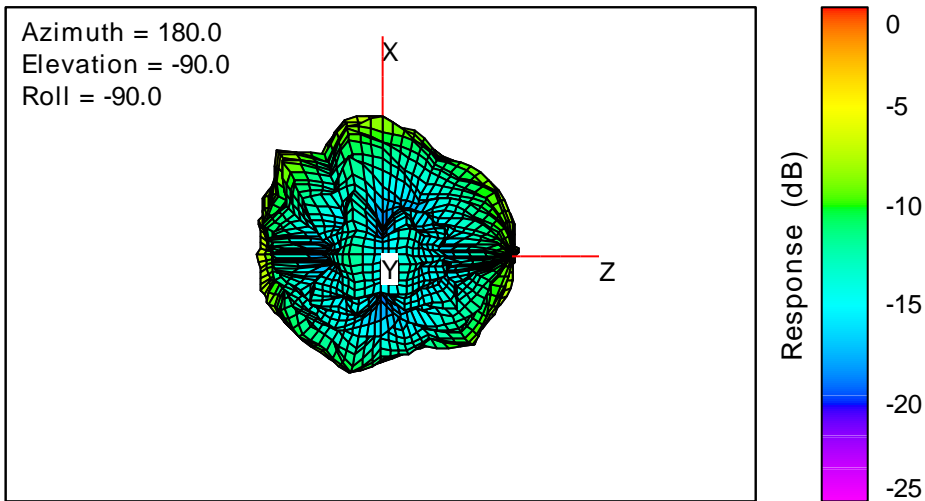

Total

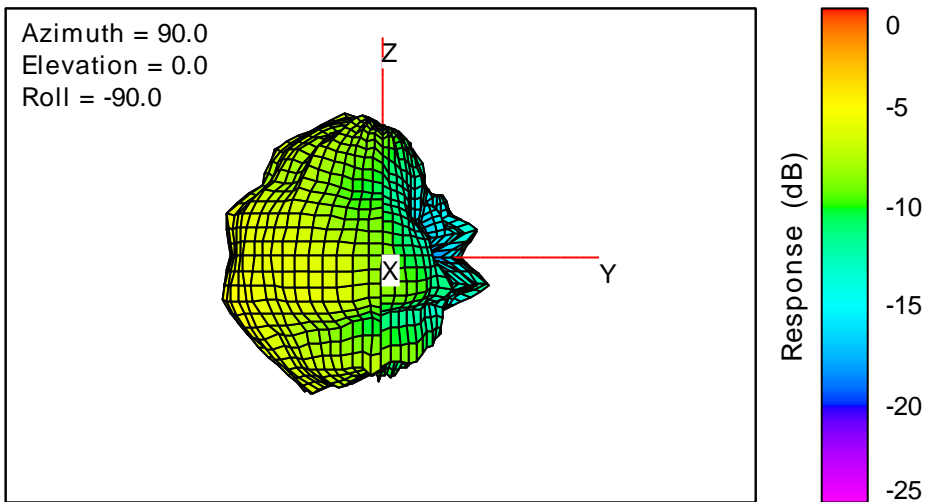

2480MHz

Total

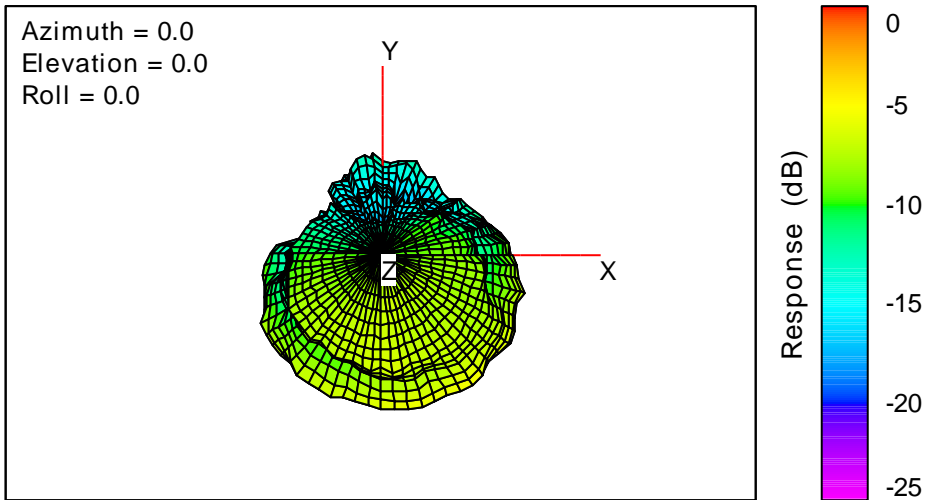

Total

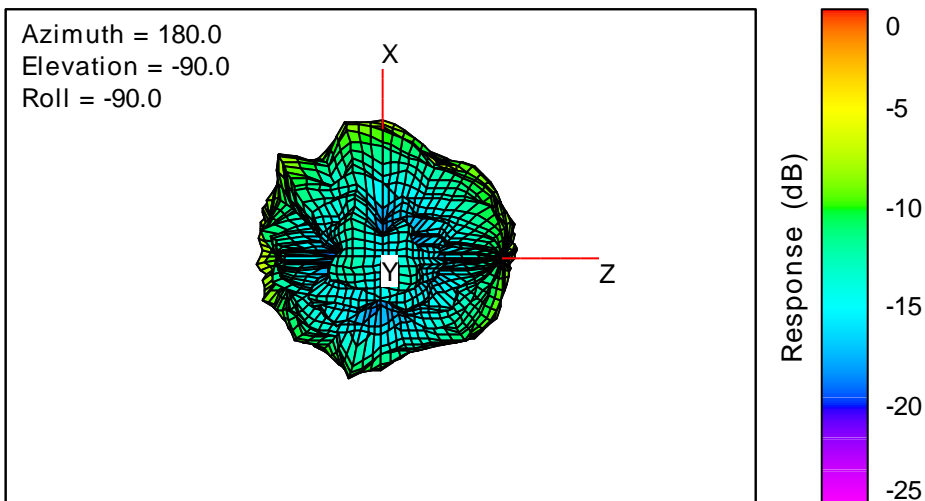

Total

