



**Shenzhen Huatongwei International Inspection Co., Ltd.**

Keji S,12th , Road, Hi-tech Industrial Park, Shenzhen, Guangdong, China

Phone:86-755-26748099



Fax:86-755-26748089

http://www.szhtw.com.cn

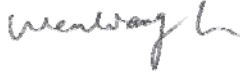
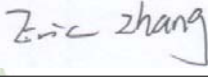

## FCC TEST REPORT

### 47 CFR FCC Part 15 Subpart C & 15.231

<b>FCC ID</b> .....	<b>OMOTX186</b>
<b>Report Reference No.</b> .....	<b>WE11080004</b>
Compiled by ( position+printed name+signature)...	File administrators Wenliang Li 
Supervised by ( position+printed name+signature)...	Test Engineer Eric Zhang 
Approved by ( position+printed name+signature)...	Manager Jeffrey Lu 
Date of issue.....	Aug 25, 2011
<b>Testing Laboratory Name</b> .....	<b>Shenzhen Huatongwei International Inspection Co., Ltd</b>
Address .....	Keji Nan No.12 Road, Hi-tech Park, Shenzhen, China
<b>Applicant's name</b> .....	<b>La Crosse Technology</b>
Address .....	2809 LOSEY BLVD SO.LA CROSSE WI 54601
<b>Manufacturer's name</b> .....	<b>Ansen Electronics Company</b>
Address .....	Chen Tung Industrial Zone,Ning Tau Administrative District, Qiao Tau Zhen, Dongguan, Guangdong
<b>Test specification:</b>	
Standard .....	<b>47 CFR FCC Part 15 Subpart C &amp; 15.231</b> <b>ANSI C63.10: 2009</b>
TRF Originator.....	Shenzhen Huatongwei International Inspection CO., Ltd
Master TRF.....	Dated 2006-06
<b>Shenzhen Huatongwei International Inspection Co., Ltd. All rights reserved.</b>	
This publication may be reproduced in whole or in part for non-commercial purposes as long as the Shenzhen Huatongwei International Inspection Co., Ltd is acknowledged as copyright owner and source of the material. Shenzhen Huatongwei International Inspection Co., Ltd takes no responsibility for and will not assume liability for damages resulting from the reader's interpretation of the reproduced material due to its placement and context.	
<b>Equipment Under Test</b> .....	<b>Transmitter(with humidity&amp;Temp,no display)</b>
Trade Mark .....	/
Model/Type reference.....	<b>TX186,W186-E</b>
Listed Models .....	/
Result.....	<b>Complied</b>

**TEST REPORT**

<b>Test Report No. :</b>	<b>WE11080004</b>	Aug 25, 2011
		Date of issue

Equipment under Test : Transmitter(with humidity&Temp,no display)

Model /Type : TX186,W186-E

Listed Models : /

**Applicant** : **La Crosse Technology**

Address : 2809 LOSEY BLVD SO.LA CROSSE WI 54601

**Manufacturer** : **Ansen Electronics Company**

Address : Chen Tung Industrial Zone,Ning Tau Administrative District, Qiao  
Tau Zhen, Dongguan, Guangdong

# Contents

- 1. TEST STANDARDS ..... 4**
  
- 2. SUMMARY ..... 5**
  - 2.1. General Remarks 5
  - 2.2. Equipment under test power supply 5
  - 2.3. Short description of the Equipment under Test (EUT) 5
  - 2.4. EUT operation mode 5
  - 2.5. Related submittal(s) / Grant (s) 5
  - 2.6. Modifications 5
  - 2.7. Block Diagram of Test Setup 6
  - 2.8. Summary of standards and result 6
  
- 3. TEST ENVIRONMENT ..... 7**
  - 3.1. Address of the test laboratory 7
  - 3.2. Test Facility 7
  - 3.3. Environmental conditions 8
  - 3.4. Statement of the measurement uncertainty 8
  - 3.5. Equipments Used during the Test 9
  
- 4. TEST CONDITIONS AND RESULTS ..... 10**
  - 4.1. AC Conducted Emission 10
  - 4.2. Radiated Emission 11
  - 4.3. Deactivation Time 20
  - 4.4. 20dB Bandwidth 24
  - 4.5. Antenna Requirement 27
  
- 5. TEST SETUP PHOTOS OF THE EUT ..... 28**
  
- 6. EXTERNAL AND INTERNAL PHOTOS OF THE EUT ..... 29**

## **1. TEST STANDARDS**

The tests were performed according to following standards:

**[47 CFR FCC Part 15 Subpart C & 15.231](#)** – Intentional Radiators & Periodic operation in the band 40.66–40.70 MHz and above 70 MHz

**[ANSI C63.10: 2009](#)** – American National Standard for Testing Unlicensed Wireless Devices

## 2. SUMMARY

### 2.1. General Remarks

Date of receipt of test sample : Aug 15, 2011

Testing commenced on : Aug 15, 2011

Testing concluded on : Aug 25, 2011

### 2.2. Equipment under test power supply

Power supply voltage :  120V / 60 Hz  115V / 60Hz  
 12 V DC  24 V DC  
 Other (specified in blank below)

DC 3V from battery

### 2.3. Short description of the Equipment under Test (EUT)

Product Name : Transmitter(with humidity&Temp,no display)

Model Number : TX186,W186-E

Operation Frequency : 433.92MHz

Modulation Technology : ASK

Transmitter Type : Periodic Transmitter

Sample Type : Prototype

I/O Port : /

For more details, refer to the user's manual of the EUT.

### 2.4. EUT operation mode

The EUT has been tested under typical operating condition.

### 2.5. Related submittal(s) / Grant (s)

This submittal(s) (test report) is intended for FCC ID: **OMOTX186** filing to comply with the FCC Part 15, Subpart C Rules.

### 2.6. Modifications

No modifications were implemented to meet testing criteria.

**2.7. Block Diagram of Test Setup**

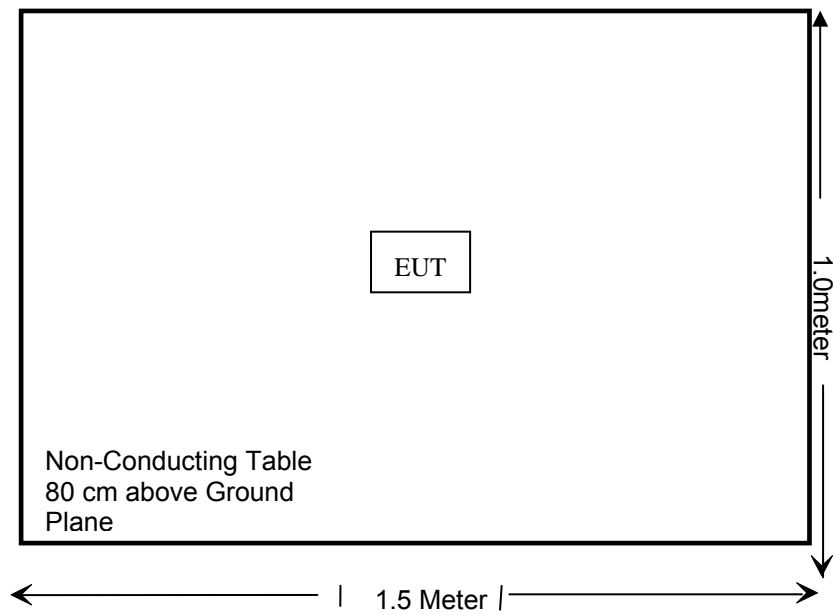

Note: For actual sample please see test setup photos and EUT external photos.

**2.8. Summary of standards and result**

FCC Rules	Description of Test	Result
§15.207 (a)	Conducted Emissions	N/A
§15.205, §15.209, 15.35 (c), §15.231 (e)	Radiated Emissions	Compliant
§15.231(e)	Deactivation Testing	Compliant
§15.231(c)	20 dB Band Width Testing	Compliant
§15.203	Antenna Requirement	Compliant

NOTE: 1) The detailed test result please see section 4.  
 2) The test report merely corresponds to the test sample.  
 3) It is not permitted to copy extracts of these test result without the written permission of the test laboratory.

### **3. TEST ENVIRONMENT**

#### **3.1. Address of the test laboratory**

Shenzhen Huatongwei International Inspection Co., Ltd  
Keji Nan No.12 Road, Hi-tech Park, Shenzhen, China  
Phone: 86-755-26715686 Fax: 86-755-26748089

The sites are constructed in conformance with the requirements of ANSI C63.7, ANSI C63.4 (2009) and CISPR Publication 22.

#### **3.2. Test Facility**

The test facility is recognized, certified, or accredited by the following organizations:

##### **CNAS-Lab Code: L1225**

Shenzhen Huatongwei International Inspection Co., Ltd has been assessed and proved to be in compliance with CNAS-CL01 Accreditation Criteria for Testing and Calibration Laboratories (identical to ISO/IEC 17025: 2005 General Requirements) for the Competence of Testing and Calibration Laboratories, Date of Registration: August 02, 2007. Valid time is until March 29, 2012.

##### **A2LA-Lab Cert. No. 2243.01**

Shenzhen Huatongwei International Inspection Co., Ltd, EMC Laboratory has been accredited by A2LA for technical competence in the field of electrical testing, and proved to be in compliance with ISO/IEC 17025: 2005 General Requirements for the Competence of Testing and Calibration Laboratories and any additional program requirements in the identified field of testing. Valid time to Sep 30, 2011.

##### **FCC-Registration No.: 662850**

Shenzhen Huatongwei International Inspection Co., Ltd, EMC Laboratory has been registered and fully described in a report filed with the FCC (Federal Communications Commission). The acceptance letter from the FCC is maintained in our files. Registration 662850, Renewal date July 01, 2009.

##### **IC-Registration No.: 5377**

The 3m Alternate Test Site of Shenzhen Huatongwei International Inspection Co., Ltd has been registered by Certification and Engineering Bureau of Industry Canada for the performance of radiated measurements with Registration No. 5377 on Jan 24th, 2014.

##### **ACA**

Shenzhen Huatongwei International Inspection Co., Ltd, EMC Laboratory can also perform testing for the Australian C-Tick mark as a result of our A2LA accreditation.

##### **NEMKO-Aut. No.: ELA125**

Shenzhen Huatongwei International Inspection Co., Ltd has been assessed the quality assurance system, the testing facilities, qualifications and testing practices of the relevant parts of the organization. The quality assurance system of the Laboratory has been validated against ISO/IEC 17025:2005 or equivalent. The laboratory also fulfils the conditions described in Nemko Document NLA-10, the Authorization is valid through July 07, 2014.

##### **VCCI**

The 3m Semi-anechoic chamber (12.2m×7.95m×6.7m) and Shielded Room (8m×4m×3m) of Shenzhen Huatongwei International Inspection Co., Ltd has been registered in accordance with the Regulations for Voluntary Control Measures with Registration No.: R-2484. Date of Registration: December 20, 2009. Valid time is until December 19, 2012.

Main Ports Conducted Interference Measurement of Shenzhen Huatongwei International Inspection Co., Ltd has been registered in accordance with the Regulations for Voluntary Control Measures with Registration No.: C-2726. Date of Registration: December 20, 2009. Valid time is until December 19, 2012.

## DNV

Shenzhen Huatongwei International Inspection Co Ltd has been found to comply with the requirements of DNV towards subcontractor of EMC and safety testing services in conjunction with the EMC and Low voltage Directives and in the voluntary field. The acceptance is based on a formal quality Audit and follow-ups according to relevant parts of ISO/IEC Guide 17025(2005), in accordance with the requirements of the DNV Laboratory Quality Manual towards subcontractors. Valid time is until 24 Aug, 2013.

### 3.3. Environmental conditions

During the measurement the environmental conditions were within the listed ranges:

Temperature:	<u>22 ° C</u>
Humidity:	<u>65 %</u>
Atmospheric pressure:	<u>950-1050mbar</u>

### 3.4. Statement of the measurement uncertainty

The data and results referenced in this document are true and accurate. The reader is cautioned that there may be errors within the calibration limits of the equipment and facilities. The measurement uncertainty was calculated for all measurements listed in this test report acc. to CISPR 16 - 4 „Specification for radio disturbance and immunity measuring apparatus and methods – Part 4: Uncertainty in EMC Measurements“ and is documented in the Shenzhen Huatongwei International Inspection Co., Ltd quality system acc. to DIN EN ISO/IEC 17025. Furthermore, component and process variability of devices similar to that tested may result in additional deviation. The manufacturer has the sole responsibility of continued compliance of the device.

Hereafter the best measurement capability for Shenzhen Huatongwei laboratory is reported:

Test Item	Frequency Range	Measurement Uncertainty	Notes
Radiated Emission	0.09~30MHz	3.85dB	(1)
Radiated Emission	30~1000MHz	4.22dB	(1)
Radiated Emission	1~12.75GHz	4.35dB	(1)
20dB Bandwidth	/	0.25dB	(1)
Deactivation Time	/	0.5ms	(1)

- (1) This uncertainty represents an expanded uncertainty expressed at approximately the 95% confidence level using a coverage factor of k=2.



### 3.5. Equipments Used during the Test

Conducted Emissions					
Item	Test Equipment	Manufacturer	Model No.	Serial No.	Last Cal.
1	EMI Test Receiver	ROHDE & SCHWARZ	ESCI	100106	2010/10/24
2	Artificial Mains	ROHDE & SCHWARZ	ESH2-Z5	100028	2010/10/24
3	Pulse Limiter	ROHDE & SCHWARZ	ESHSZ2	100044	2010/10/24
4	EMI Test Software	ROHDE & SCHWARZ	ESK1	N/A	2010/10/24

Radiated Emissions					
Item	Test Equipment	Manufacturer	Model No.	Serial No.	Last Cal.
1	ULTRA-BROADBAND ANTENNA	ROHDE & SCHWARZ	HL562	100015	2010/10/24
2	Amplifier	Sonoma	310 N	291722	2010/10/24
3	EMI TEST RECEIVER	ROHDE & SCHWARZ	ESI 26	100009	2010/10/24
4	RF TEST PANEL	ROHDE & SCHWARZ	TS / RSP	335015/ 0017	2010/10/24
5	TURNTABLE	ETS	2088	2149	2010/10/24
6	ANTENNA MAST	ETS	2075	2346	2010/10/24
7	EMI TEST SOFTWARE	ROHDE & SCHWARZ	ESK1	N/A	2010/10/24
8	Double-Ridged-Waveguide Horn Antenna	ROHDE & SCHWARZ	HF906	100039	2010/10/24
9	Amplifier	ROHDE & SCHWARZ	HF906 (1-18)GMZ	00101800-28-5A	2010/10/24
10	Loop Antenna	ROHDE & SCHWARZ	HFH2-Z2	100020	2010/10/24

20dB Bandwidth & Deactivation Time & Duty Cycle					
Item	Test Equipment	Manufacturer	Model No.	Serial No.	Last Cal.
1	EMI Test Receiver	ROHDE & SCHWARZ	ESCI	100106	2010/10/24

## 4. TEST CONDITIONS AND RESULTS

### 4.1. AC Conducted Emission

#### TEST CONFIGURATION

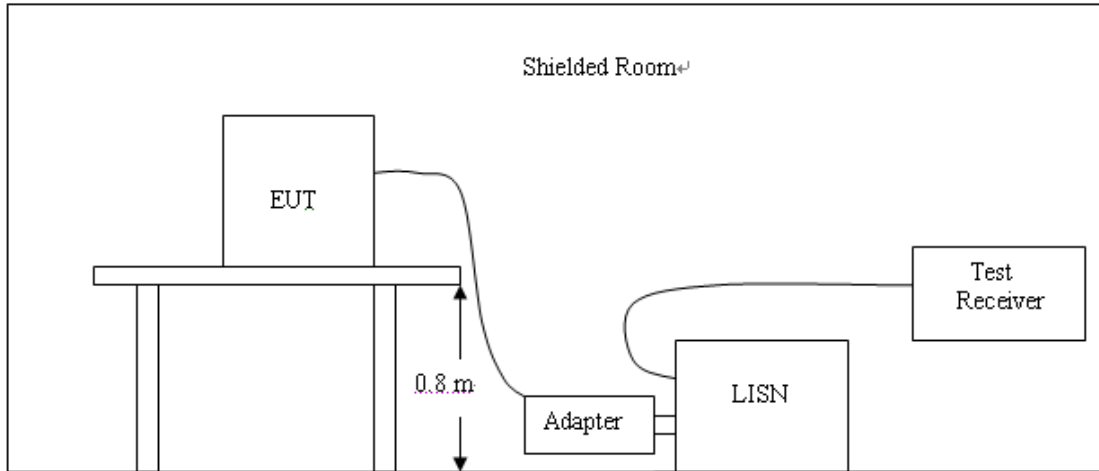

#### TEST PROCEDURE

- 1 The equipment was set up as per the test configuration to simulate typical actual usage per the user's manual. The EUT is a Transmitter (with humidity & Temp, no display); a wooden table with a height of 0.8 meters is used and is placed on the ground plane as per ANSI C63.10.
- 2 Support equipment, if needed, was placed as per ANSI C63.10.
- 3 All I/O cables were positioned to simulate typical actual usage as per ANSI C63.10.
- 4 All support equipments received AC power from a second LISN, if any.
- 5 The EUT test program was started. Emissions were measured on each current carrying line of the EUT using a spectrum Analyzer / Receiver connected to the LISN powering the EUT. The LISN has two monitoring points: Line 1 (Hot Side) and Line 2 (Neutral Side). Two scans were taken: one with Line 1 connected to Analyzer / Receiver and Line 2 connected to a 50 ohm load; the second scan had Line 1 connected to a 50 ohm load and Line 2 connected to the Analyzer / Receiver.
- 6 Analyzer / Receiver scanned from 150 KHz to 30MHz for emissions in each of the test modes.
- 7 During the above scans, the emissions were maximized by cable manipulation.

#### CONDUCTED LIMIT

According to FCC Subpart 15 B § 15.207 AC Conducted Emission Limits is as following :

Frequency fange (MHz)	Conducted limit (dBµV)	
	Quasi-peak	Average
0.1~ 0.5	66 to 56*	56 to 46*
0.5 ~ 5	56	46
5 ~ 30	60	50

\* Decreasing linearly with the logarithm of the frequency

#### TEST RESULTS

Not applicable to this device (because the equipment without any AC port)

### 4.2. Radiated Emission

#### TEST CONFIGURATION

Radiated Emission Test Set-Up

Frequency range 9KHz – 30MHz

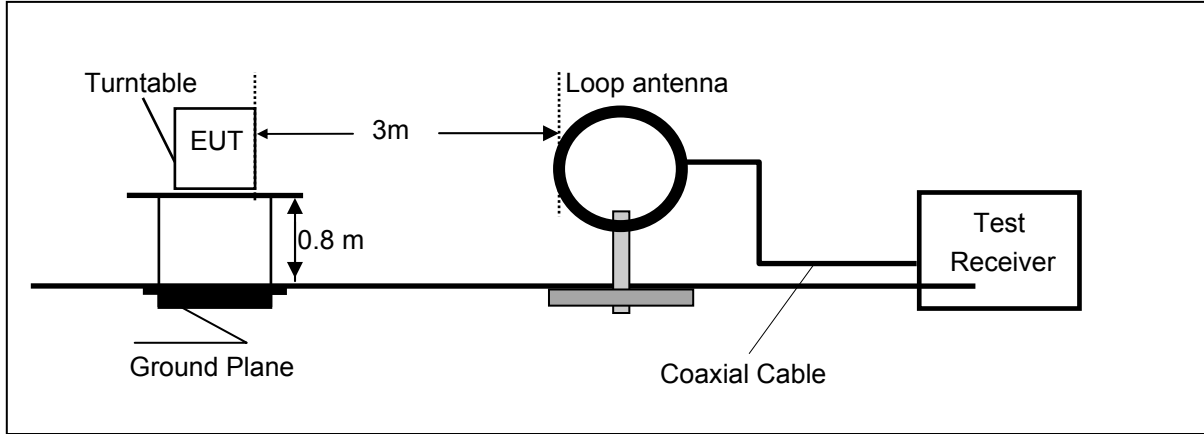

Frequency range 30MHz – 1000MHz

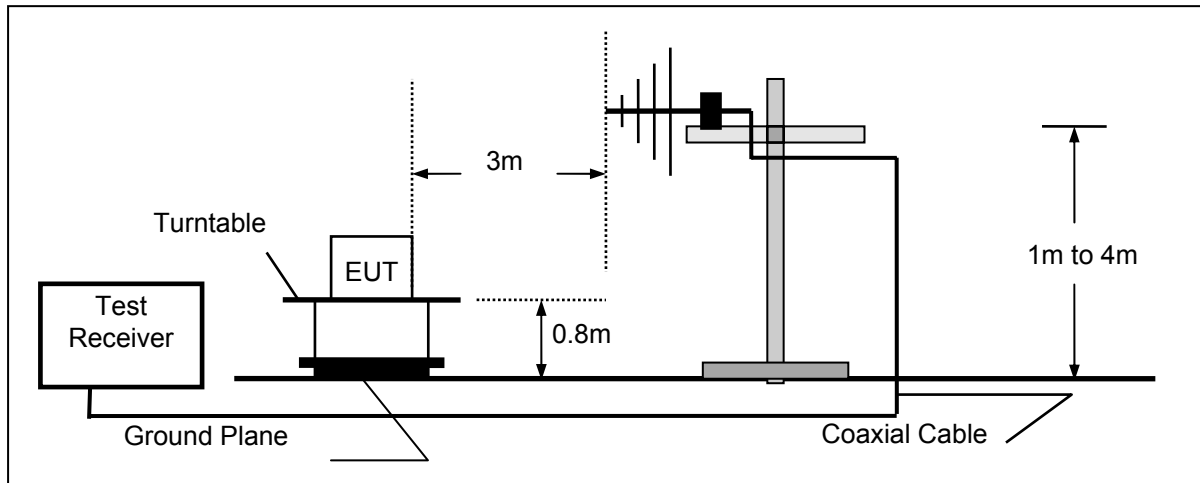

Frequency range 1GHz – 5GHz

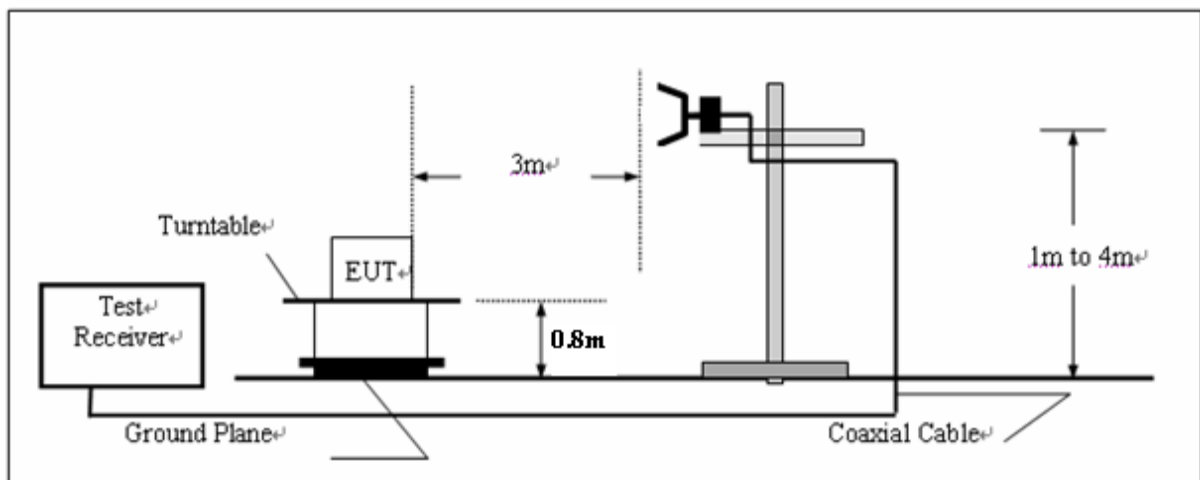

**TEST PROCEDURE**

- 1, The EUT was placed on a turn table which is 0.8m above ground plane, Put the battery into the EUT and the EUT will transmit automatic at 433.92MHz.
- 2, Maximum procedure was performed by raising the receiving antenna from 1m to 4m and rotating the turn table from 0 ° to 360 ° to acquire the highest emissions from EUT., each emission was to be maximized by changing the polarization of receiving antenna both horizontal and vertical.
- 3, Repeat above procedures until all frequency measurements have been completed.

**EMI Test Receiver Setup**

The system was investigated from 9 KHz to 5 GHz.

During the radiated emission test, the test receiver was set with the following configurations:

<b>Frequency Range</b>	<b>RBW</b>	<b>VBW</b>	<b>Dectector</b>
9kHz– 150kHz	200 Hz	1 kHz	QP
150kHz– 30 MHz	9 KHz	30 KHz	QP
30MHz – 1000 MHz	100 kHz	300 kHz	QP
1000 MHz – 5 GHz	1 MHz	3 MHz	PK
1000 MHz – 5 GHz	1 MHz	10 Hz	AV

Note: The measurement employ AV detector for the frequency bands 9KHz-90KHz and 110KHz-490KHz .

**RADIATION LIMIT**

For periodic transmitter, according to § 15.231(e), the field strength of fundamental from device at a distance of 3 meters shall not exceed the following values:

<b>Fundamental frequency (MHz)</b>	<b>Distance (Meters)</b>	<b>Field strength of fundamental</b>	
		<b>(<math>\mu</math>V/m)</b>	<b>(dB<math>\mu</math>V/m)</b>
40.66-40.70	3	1000	60
70-130	3	500	54
130-174	3	500 to 1500	54 to 63.5
174-260	3	1500	63.5
260-470	3	1500 to 5000	63.5 to 74
Above 470	3	5000	74

For periodic transmitter, according to § 15.231(e), the field strength radiated emissions from device at a distance of 3 meters shall not exceed the following values:

Fundamental frequency (MHz)	Distance (Meters)	Field strength of spurious emission	
		( $\mu\text{V/m}$ )	(dB $\mu\text{V/m}$ )
40.66-40.70	3	100	40
70-130	3	50	34
130-174	3	50 to 150	34 to 43.5
174-260	3	150	43.5
260-470	3	150 to 500	43.5 to 54
Above 470	3	500	54

Note: 1, For other bands limit pls refer 15.209  
 2, The limit below 1GHz based CISPR quasi-peak detector, the limit above 1GHz based average detector and peak limit is 74dB $\mu\text{V/m}$ .

FCC Part 15B § 15.209, all spurious emissions shall comply with the limits of table as follow:

Frequency (MHz)	Distance (Meters)	Radiated ( $\mu\text{V/m}$ )	Radiated (dB $\mu\text{V/m}$ )
30-88	3	100	40.0
88-216	3	150	43.5
216-960	3	200	46.0
Above 960	3	500	54.0

Note: The spurious emissions shall be attenuated to the average limits shown in above table or to the general limits shown in section 15.209, which limit permits a higher field strength.

**TEST RESULTS**

The emissions from 30MHz to 5GHz are measured peak and average level, below 1GHz measured QP level,detailed test data please see below. The pre-test have done for the EUT in three axes and the worst data is recorded in the report.

**Radiated emission of fundamental emission of Channel 1**

Frequency (MHz)	Corrected Reading (dB $\mu\text{V/m}$ )@3m	FCC Limit (dB $\mu\text{V/m}$ ) @3m	Margin (dB)	Detector	Polarization
433.92	80.20	92.87	12.67	PK	Horizontal
433.92	64.02	72.87	8.85	AV	Horizontal
433.92	86.50	92.87	6.37	PK	Vertical
433.92	70.32	72.87	2.55	AV	Vertical

**Spurious radiated emission of Channel 1**

Frequency (MHz)	Corrected Reading (dB $\mu$ V/m)@3m	FCC Limit (dB $\mu$ V/m) @3m	Margin (dB)	Detector	Polarization
10.25	31.22	69.54	38.32	QP	/
21.52	32.54	69.54	37.00	QP	/
86.54	34.26	40.00	5.74	QP	Horizontal
692.54	41.56	46.00	4.44	QP	Horizontal
868.14	43.68	72.87	29.19	PK	Horizontal
868.14	27.50	52.87	25.37	AV	Horizontal
1302.50	45.26	72.87	27.61	PK	Horizontal
1302.50	29.08	52.87	23.79	AV	Horizontal
3036.07	47.36	72.87	25.51	PK	Horizontal
3036.07	31.18	52.87	21.69	AV	Horizontal
86.54	35.22	40.00	4.78	QP	Vertical
692.54	40.52	46.00	5.48	QP	Vertical
868.14	43.10	72.87	29.77	PK	Vertical
868.14	26.92	52.87	25.95	AV	Vertical
1302.50	49.70	72.87	23.17	PK	Vertical
1302.50	33.52	52.87	19.35	AV	Vertical
3036.07	51.20	72.87	21.67	PK	Vertical
3036.07	35.02	52.87	17.85	AV	Vertical

**Radiated emission of fundamental emission of Channel 2**

Frequency (MHz)	Corrected Reading (dB $\mu$ V/m)@3m	FCC Limit (dB $\mu$ V/m) @3m	Margin (dB)	Detector	Polarization
433.92	80.30	92.87	12.57	PK	Horizontal
433.92	63.24	72.87	9.63	AV	Horizontal
433.92	86.70	92.87	6.17	PK	Vertical
433.92	69.64	72.87	3.23	AV	Vertical

**Spurious radiated emission of Channel 2**

Frequency (MHz)	Corrected Reading (dB $\mu$ V/m)@3m	FCC Limit (dB $\mu$ V/m) @3m	Margin (dB)	Detector	Polarization
10.25	30.58	69.54	33.96	QP	/
21.52	32.85	69.54	36.69	QP	/
86.54	34.52	40.00	5.48	QP	Horizontal
692.54	39.85	46.00	6.15	QP	Horizontal
868.14	43.51	72.87	29.36	PK	Horizontal
868.14	26.45	52.87	26.42	AV	Horizontal
1302.50	44.52	72.87	28.35	PK	Horizontal
1302.50	27.46	52.87	25.41	AV	Horizontal
3036.07	48.52	72.87	24.35	PK	Horizontal
3036.07	31.46	52.87	21.41	AV	Horizontal
86.54	35.54	40.00	4.46	QP	Vertical
692.54	40.68	46.00	5.32	QP	Vertical
868.14	42.21	72.87	30.66	PK	Vertical
868.14	25.15	52.87	27.72	AV	Vertical
1302.50	49.54	72.87	23.33	PK	Vertical
1302.50	32.48	52.87	20.39	AV	Vertical
3036.07	50.24	72.87	22.63	PK	Vertical
3036.07	33.18	52.87	19.69	AV	Vertical

**Radiated emission of fundamental emission of Channel 3**

Frequency (MHz)	Corrected Reading (dB $\mu$ V/m)@3m	FCC Limit (dB $\mu$ V/m) @3m	Margin (dB)	Detector	Polarization
433.92	80.20	92.87	12.67	PK	Horizontal
433.92	63.44	72.87	9.43	AV	Horizontal
433.92	86.50	92.87	6.37	PK	Vertical
433.92	69.74	72.87	3.13	AV	Vertical

## Spurious radiated emission of Channel 3

Frequency (MHz)	Corrected Reading (dB $\mu$ V/m)@3m	FCC Limit (dB $\mu$ V/m) @3m	Margin (dB)	Detector	Polarization
10.25	31.20	69.54	38.34	QP	/
21.52	33.60	69.54	35.94	QP	/
86.54	33.65	40.00	6.35	QP	Horizontal
692.54	40.32	46.00	5.68	QP	Horizontal
868.14	43.10	72.87	29.77	PK	Horizontal
868.14	26.34	52.87	26.53	AV	Horizontal
1302.50	44.70	72.87	28.17	PK	Horizontal
1302.50	27.94	52.87	24.93	AV	Horizontal
3036.07	46.50	72.87	26.37	PK	Horizontal
3036.07	29.74	52.87	23.13	AV	Horizontal
86.54	34.65	40.00	5.35	QP	Vertical
692.54	40.62	46.00	5.38	QP	Vertical
868.14	43.21	72.87	29.66	PK	Vertical
868.14	26.45	52.87	26.42	AV	Vertical
1302.50	48.69	72.87	24.18	PK	Vertical
1302.50	31.93	52.87	20.94	AV	Vertical
3036.07	49.92	72.87	22.95	PK	Vertical
3036.07	33.16	52.87	19.71	AV	Vertical

Note 1: According to section 15.35(b), when average radiated emission measurements are specified, including emission measurement below 1000MHz, there also is limit on the radio frequency emissions, as measured using instrumentation with a peak detector function, corresponding to 20dB above the maximum permitted average limit for the frequency being investigated.

Note 2: Average Result =Peak Field Strength+Duty Cycle Correction Factor.

Note 3: Duty Cycle Correction Factor value refers to below.



**Duty Cycle Correction Factor**

**Channel 1**

Total pulse on time:0.501 millisecond  
Duty Cycle = TX on/100ms X 100% = 0.501\*31 ms/100ms X 100% =15.53%  
Duty Cycle Correction Factor = 20log (Duty Cycle) = -16.18

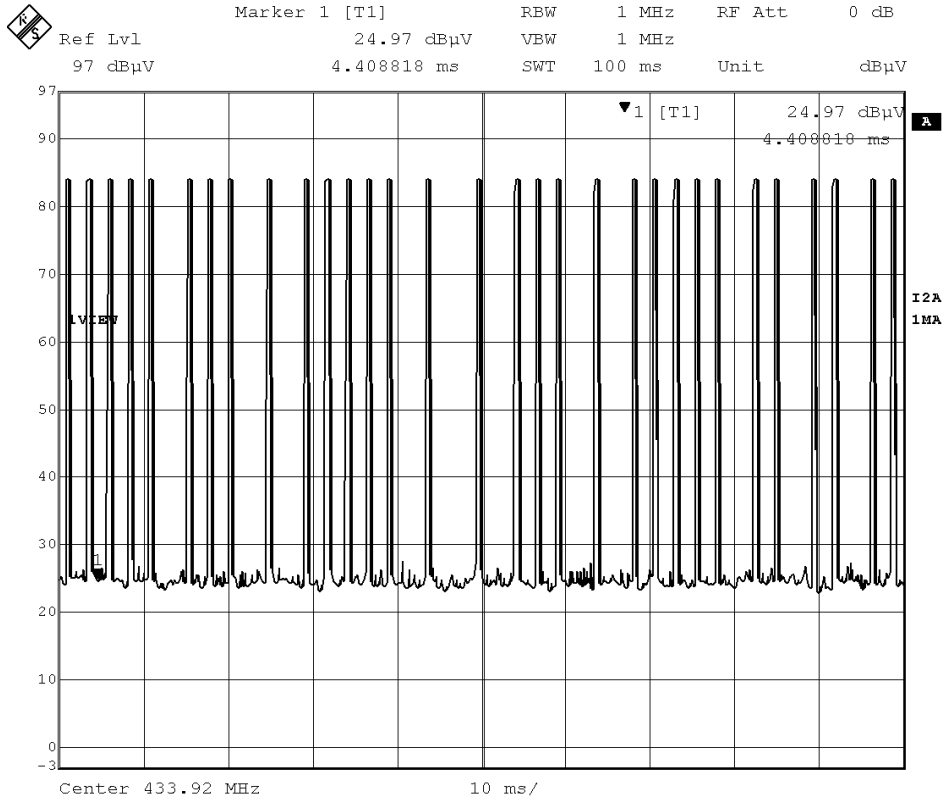

Date: 22.AUG.2011 15:22:32

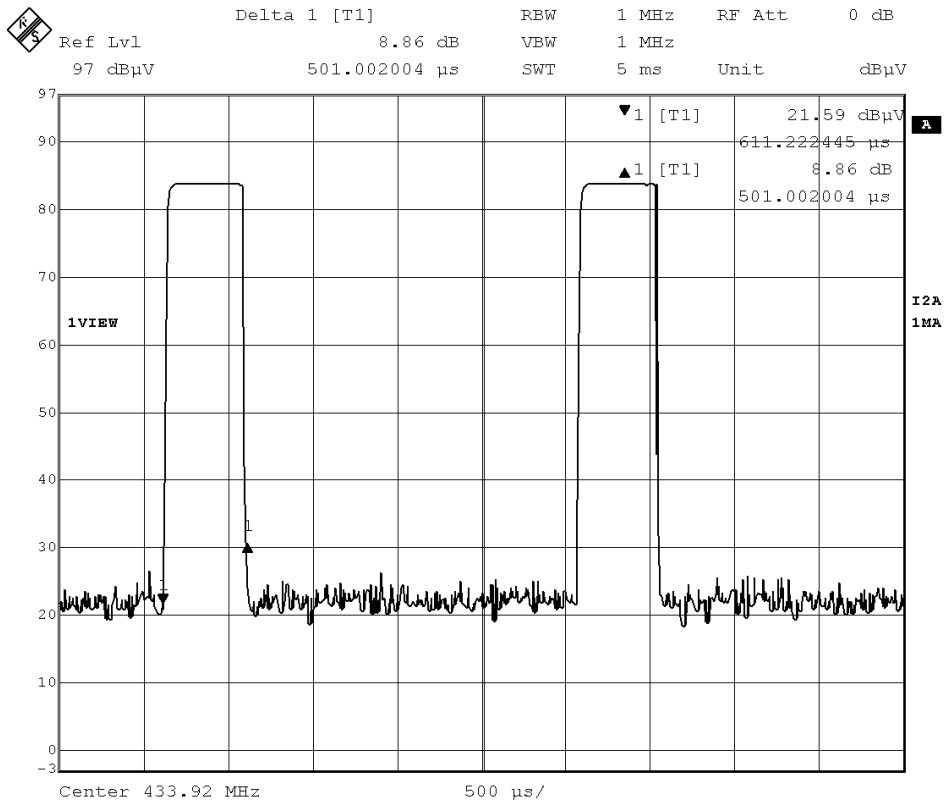

Date: 22.AUG.2011 15:17:20

Channel 2

Total pulse on time:0.501 millisecond  
Duty Cycle = TX on/100ms X 100% = 0.501\*28 ms/100ms X 100% =14.03%  
Duty Cycle Correction Factor = 20log (Duty Cycle) = -17.06

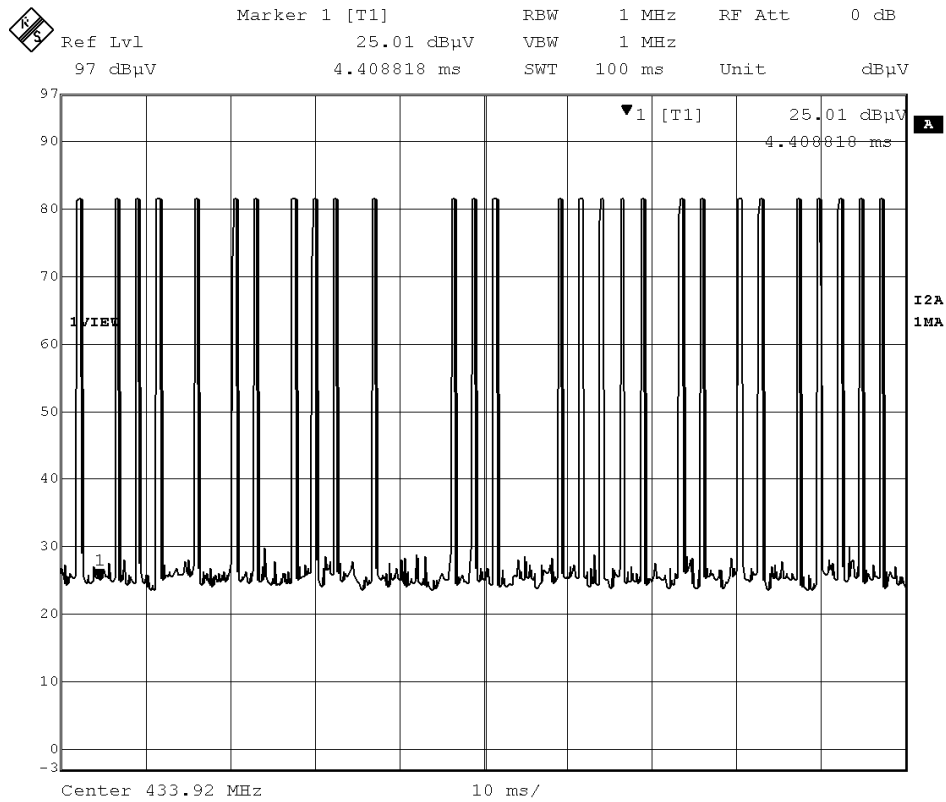

Date: 22.AUG.2011 15:21:54

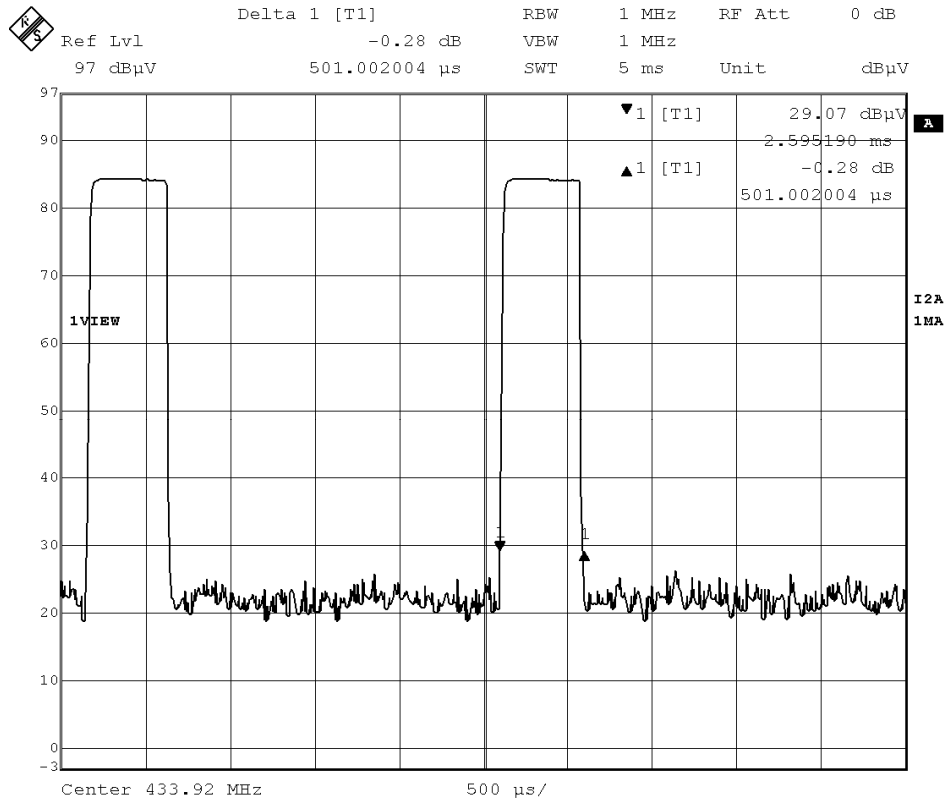

Date: 22.AUG.2011 15:19:08

Channel 3

Total pulse on time:0.501 millisecond  
Duty Cycle = TX on/100ms X 100% = 0.501\*29 ms/100ms X 100% =14.53%  
Duty Cycle Correction Factor = 20log (Duty Cycle) = -16.76

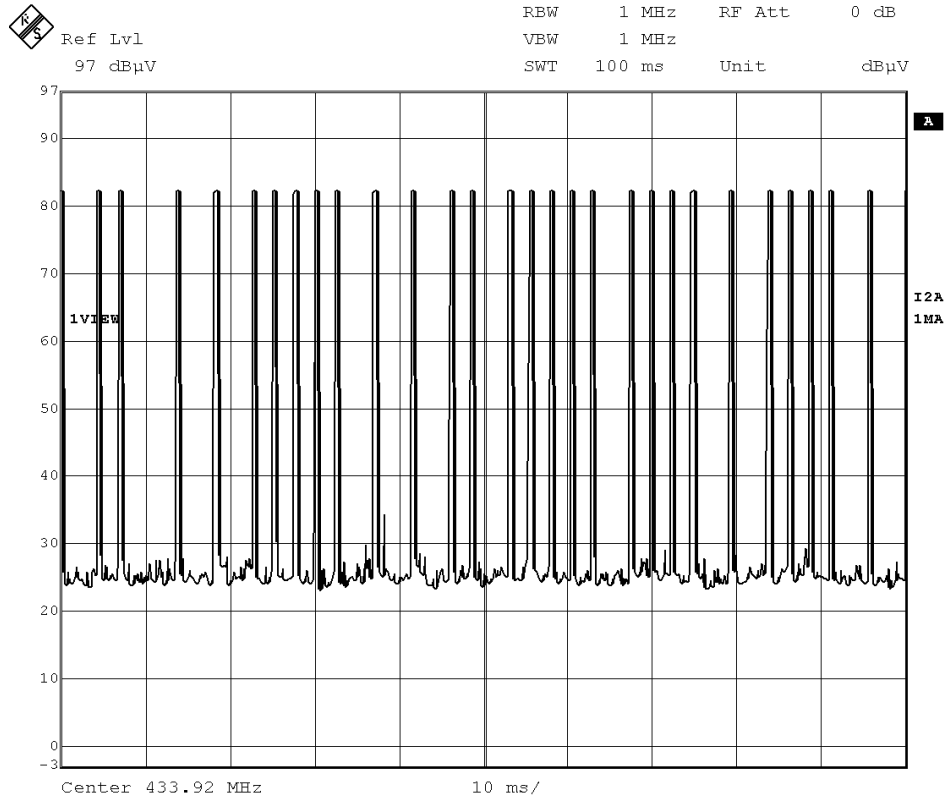

Date: 22.AUG.2011 15:21:29

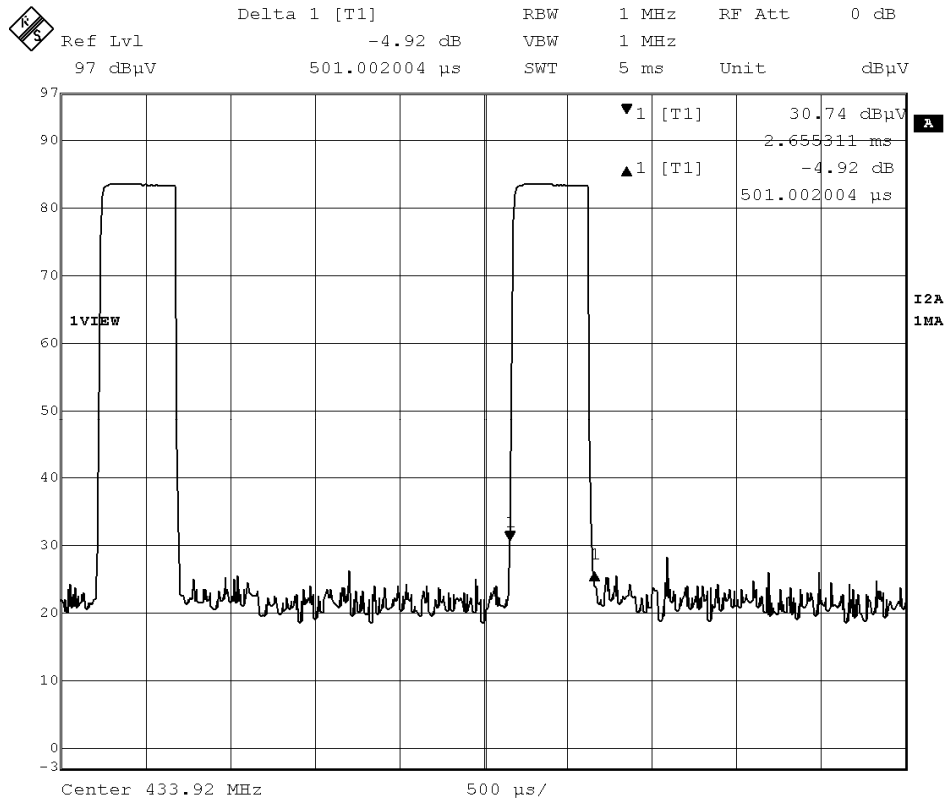

Date: 22.AUG.2011 15:20:33

### 4.3. Deactivation Time

#### TEST CONFIGURATION

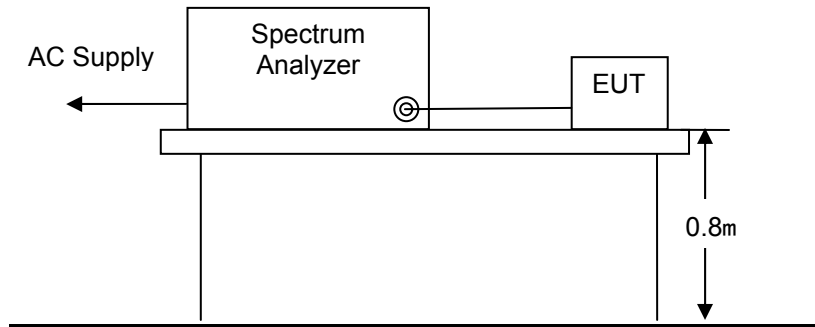

#### TEST PROCEDURE

- 1 The EUT was placed on a wooded table which is 0.8m height and close to receiver antenna of spectrum analyzer.
- 2 The spectrum analyzer resolution bandwidth was set to 1 MHz and video bandwidth was set to 1 MHz to encompass all significant spectral components during the test. The spectrum analyzer was operated in linear scale and zero span mode after tuning to the transmitter carrier frequency.

#### Limit

For periodic transmitter, according to FCC Part 15C § 15.231(e)

Item	Limit (second)
One transmission time	not greater than 1 second
Transmission period	at least 30 times the duration of the transmission but in no case less than 10 second

#### TEST RESULTS

EUT statement: The transmitter was automatically activated, and the carrier frequency 433.92MHz:

Frequency (MHz)	One transmission time (second)	Transmission period (second)	Result
Channel1(433.92)	0.987	$0.987 \times 30 = 29.61 < 30.05$	Pass
Channel2(433.92)	0.987	$0.987 \times 30 = 29.61 < 32.05$	Pass
Channel3(433.92)	0.987	$0.987 \times 30 = 29.61 < 34.05$	Pass

Channel 1

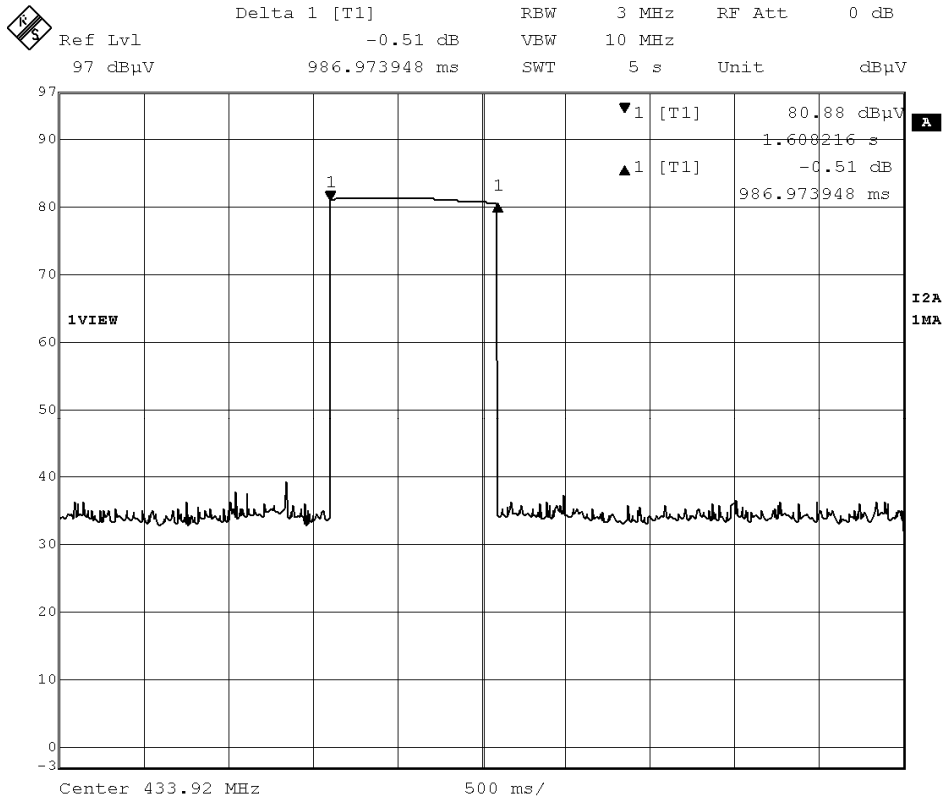

Date: 22.AUG.2011 15:54:12

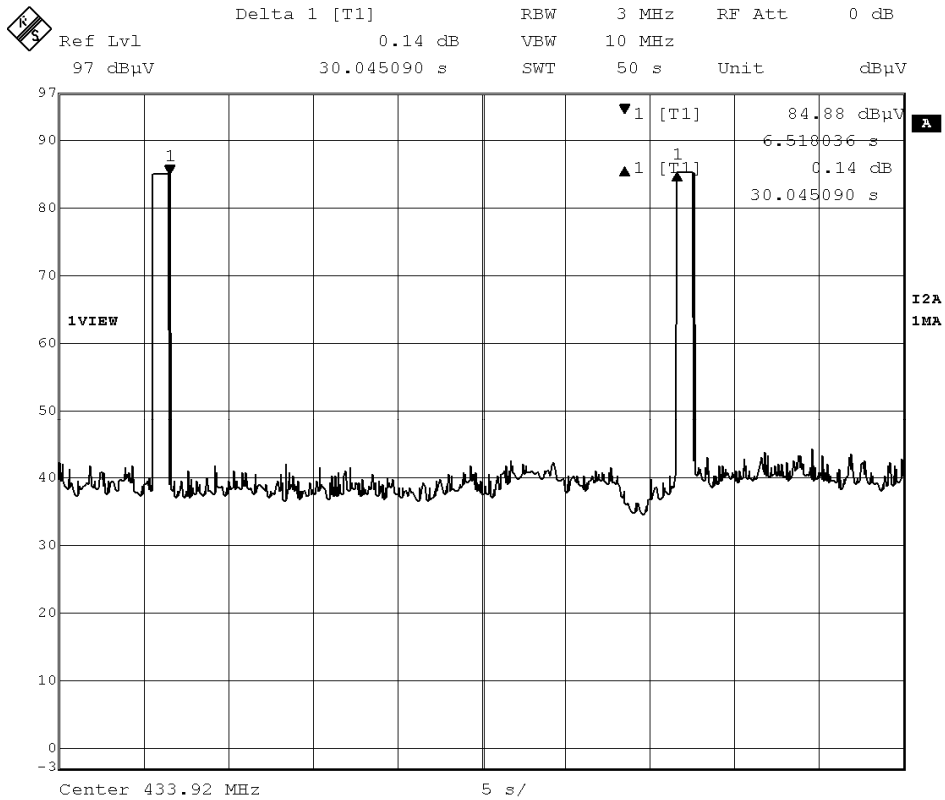

Date: 22.AUG.2011 16:03:53

**Channel 2**

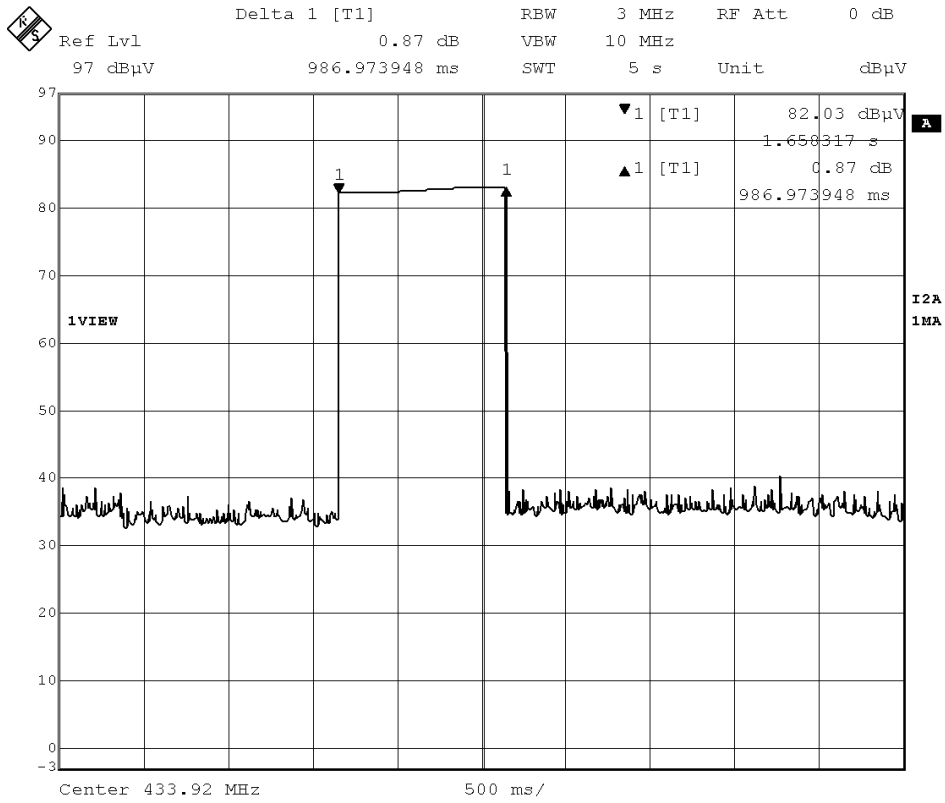

Date: 22.AUG.2011 15:52:49

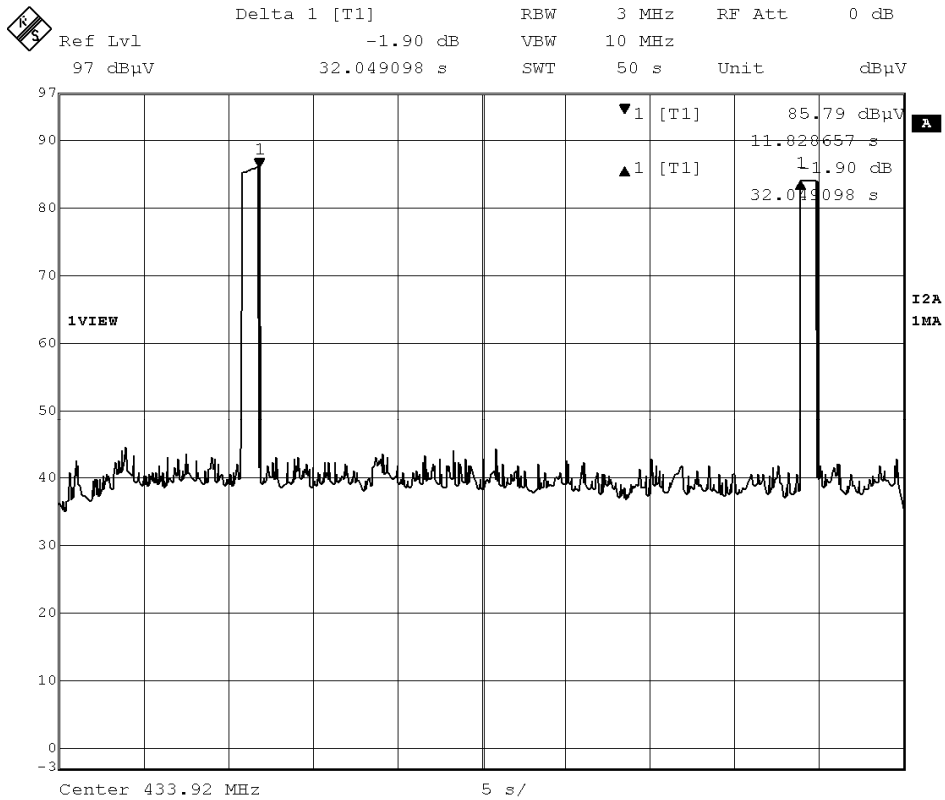

Date: 22.AUG.2011 16:01:07

**Channel 3**

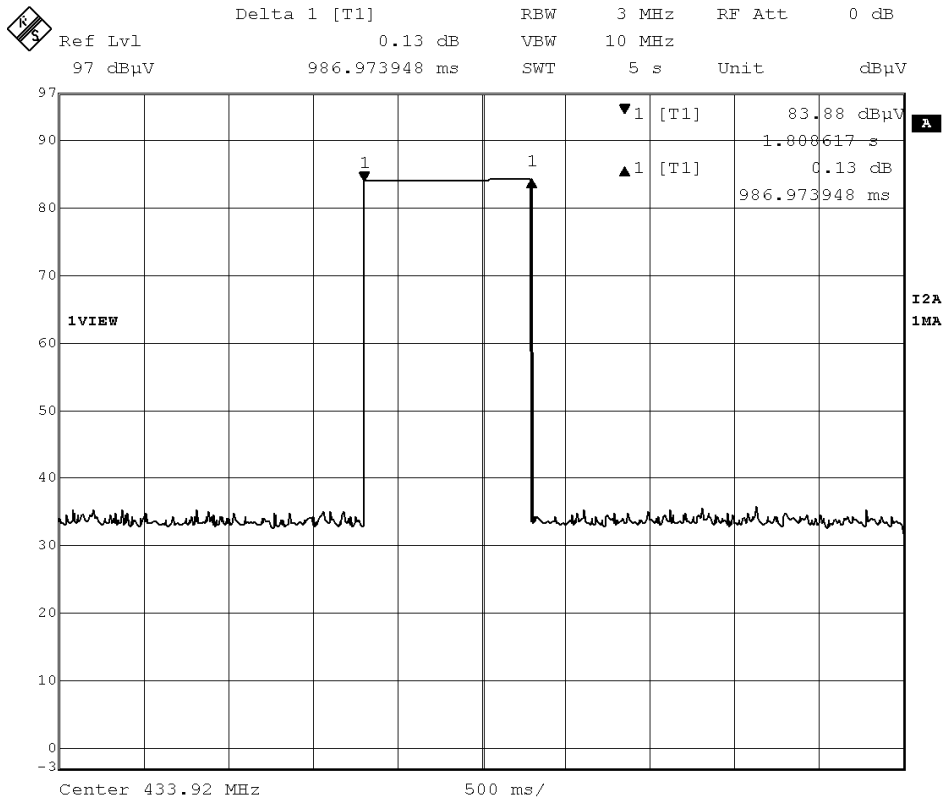

Date: 22.AUG.2011 15:55:23

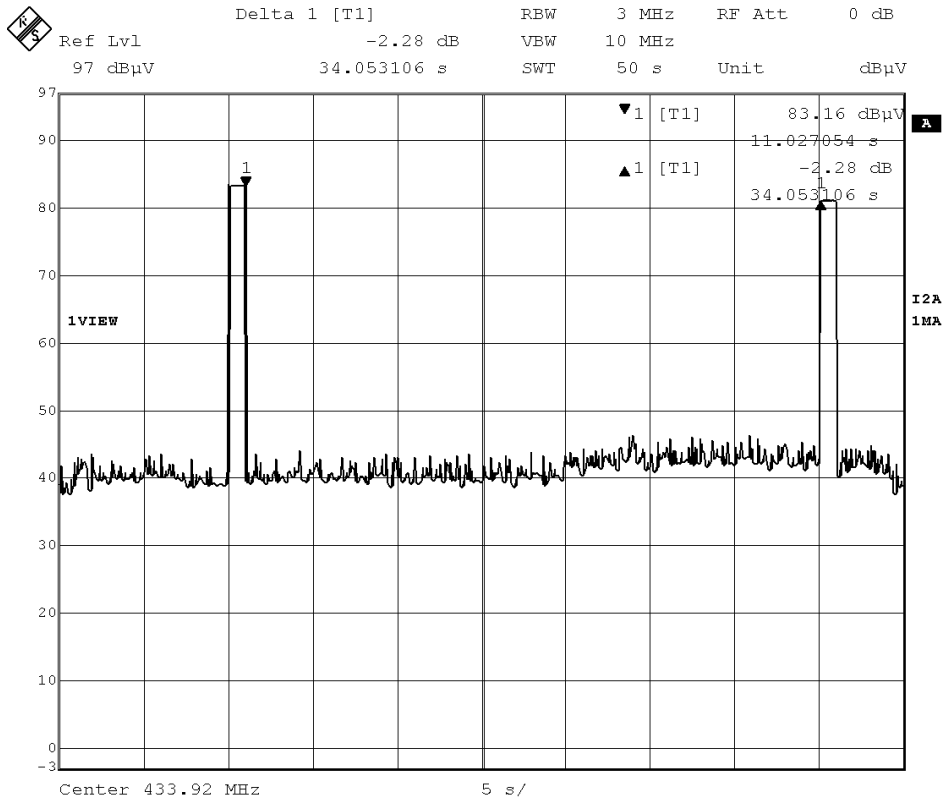

Date: 22.AUG.2011 15:59:33

**4.4. 20dB Bandwidth**

**TEST CONFIGURATION**

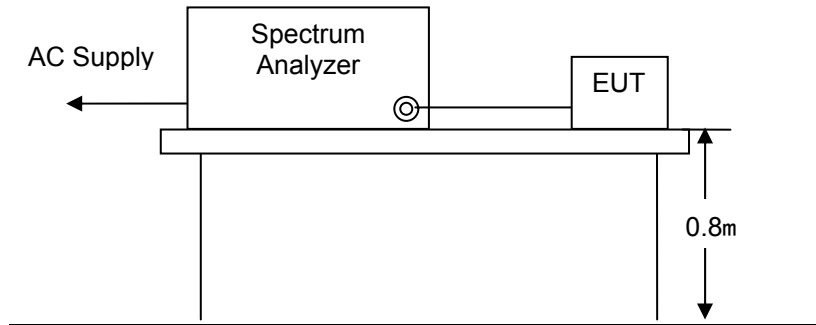

**TEST PROCEDURE**

- 1 The EUT was placed on a wooded table which is 0.8m height and close to receiver antenna of spectrum analyzer.
- 2 The spectrum analyzer resolution bandwidth was set to 10 kHz and video bandwidth was set to 30 kHz to encompass all significant spectral components during the test. The detector was set to peak and hold mode to clearly observe the components.

**Limit**

According to FCC Part 15C § 15.231(c)

The bandwidth of the emission shall be no wider than 0.25% of the center frequency for devices operating above 70MHz and below 900MHz.

**TEST RESULTS**

Frequency (MHz)	20dB Bandwidth Measurement Bandwidth (KHz)	Limit (kHz)	Result
Channel 1(433.92)	50.10	1084.80	Pass
Channel 2(433.92)	50.10	1084.80	Pass
Channel 3(433.92)	49.10	1084.80	Pass



**20dB Bandwidth**

**Channel 1**

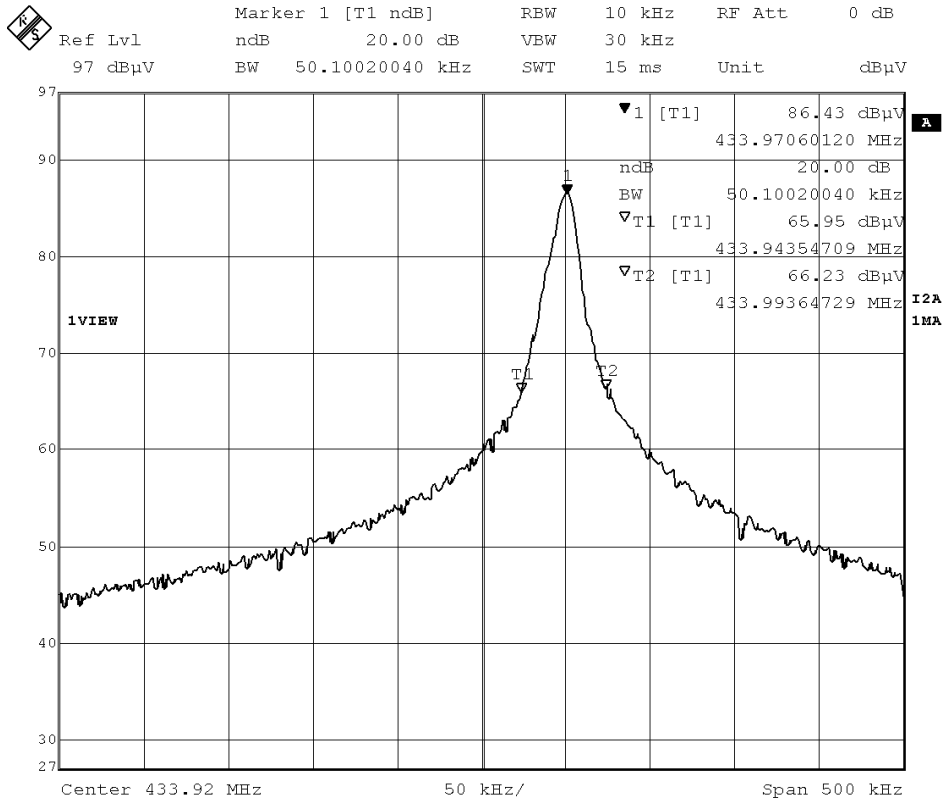

Date: 24.AUG.2011 10:34:22

**Channel 2**

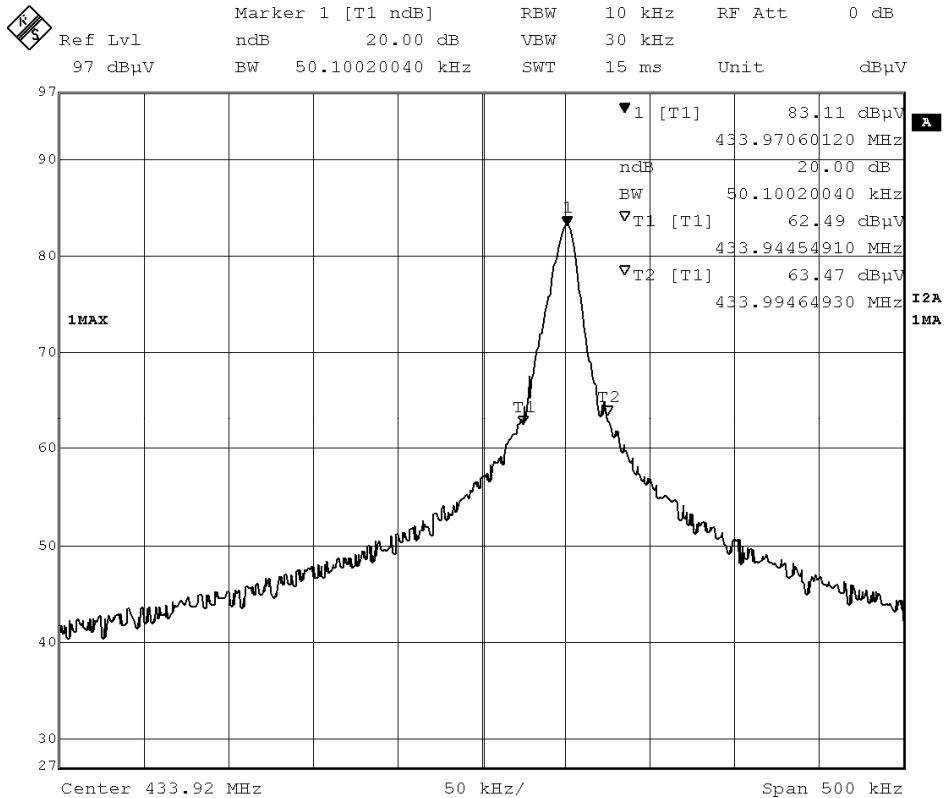

Date: 24.AUG.2011 10:37:11

**Channel 3**



Ref Lvl	Marker 1 [T1 ndB]	RBW	10 kHz	RF Att	0 dB
97 dBμV	ndB 20.00 dB	VBW	30 kHz		
	BW 49.09819639 kHz	SWT	15 ms	Unit	dBμV

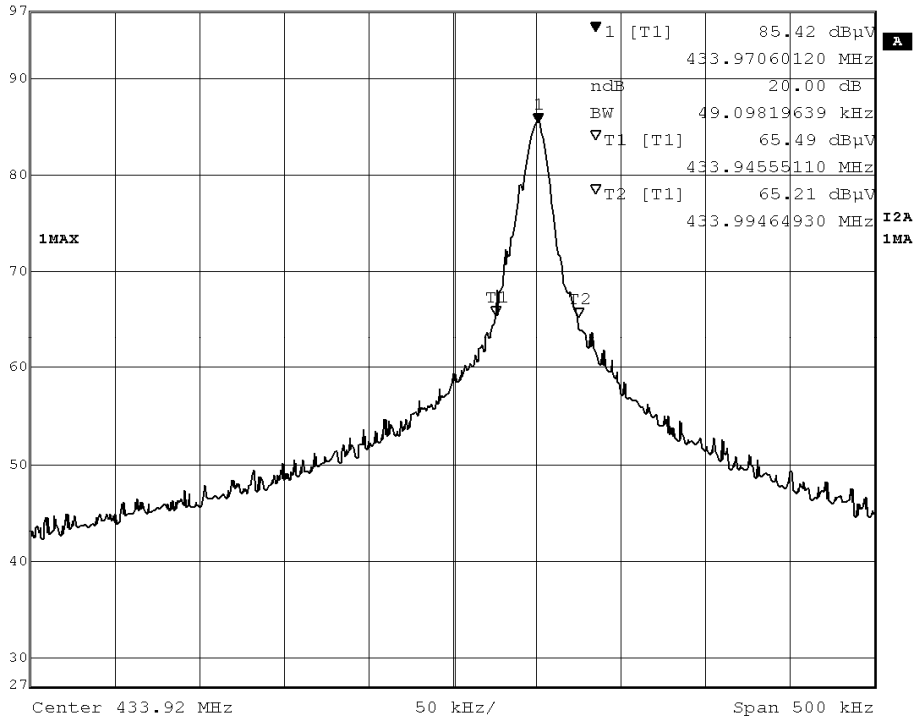

Date: 24.AUG.2011 10:42:32

### 4.5. Antenna Requirement

According to FCC Part 15C § 15.203,

- a), An intentional radiator shall be de-signed to ensure that no antenna other than that furnished by the responsible party shall be used with the device.
- b), The manufacturer may design the unit so that a broken antenna can be replaced by the user, but the use of a standard antenna jack or electrical connector is prohibited.

The EUT use of a Integral antenna. Please refer to the EUT Internal photos.

The EUT complied the antenna requirement.

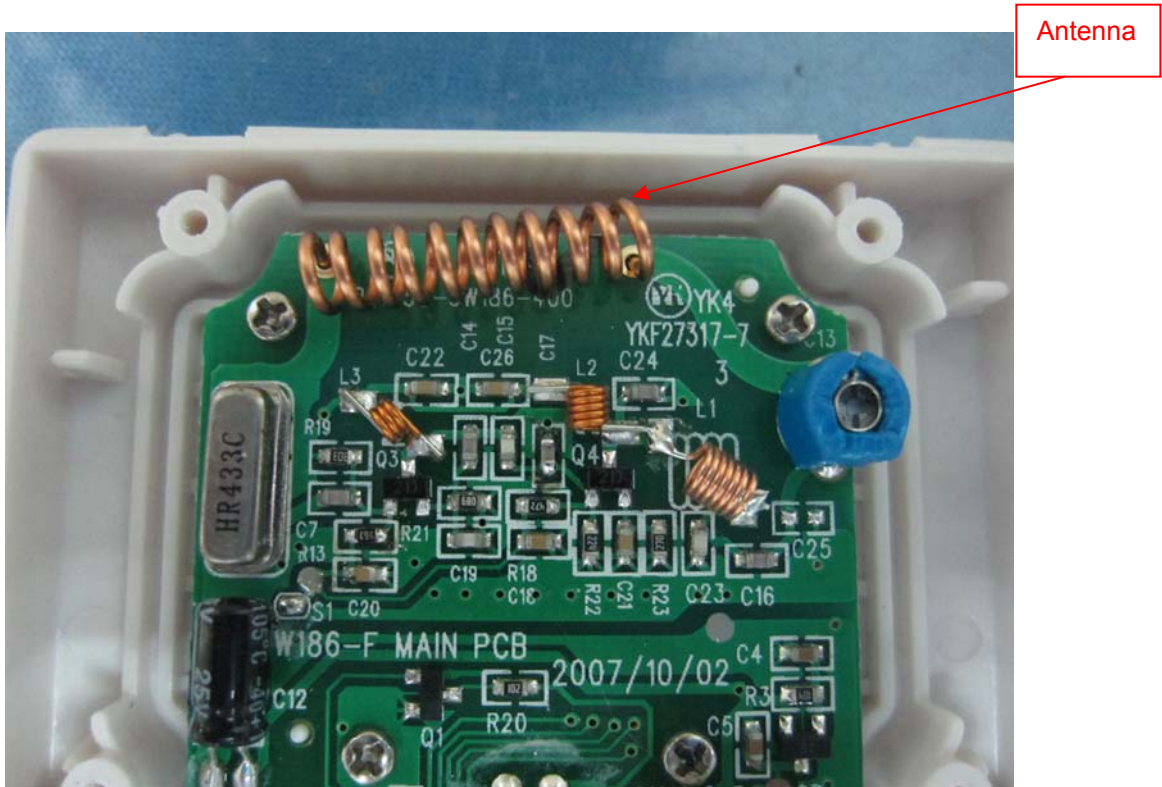

## 5. Test Setup Photos of the EUT

Radiated emission test photo

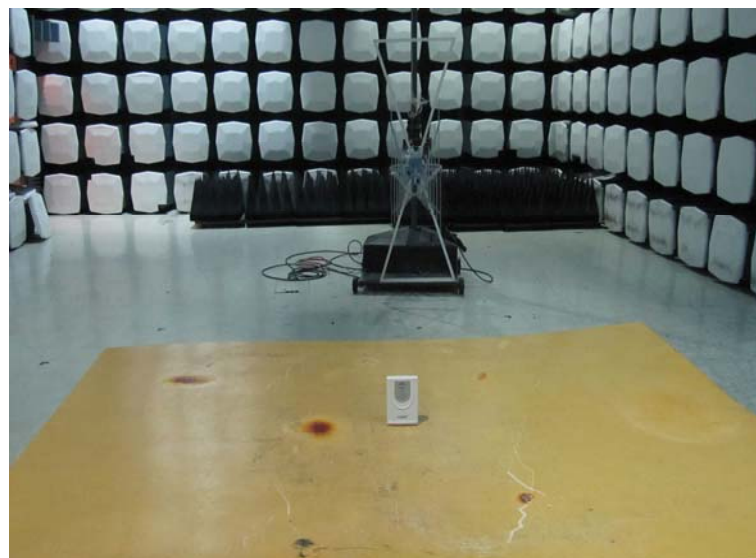

## 6. External and Internal Photos of the EUT

### External Photos&antenna photo



Internal Photos

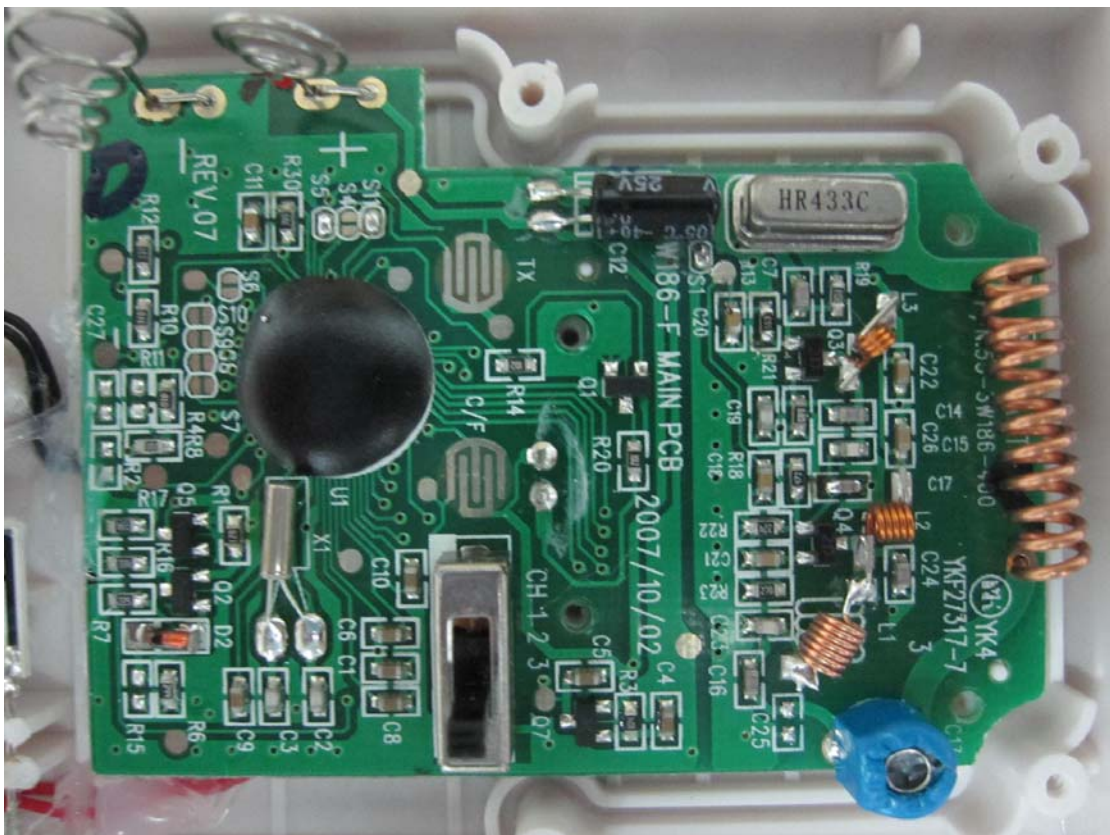

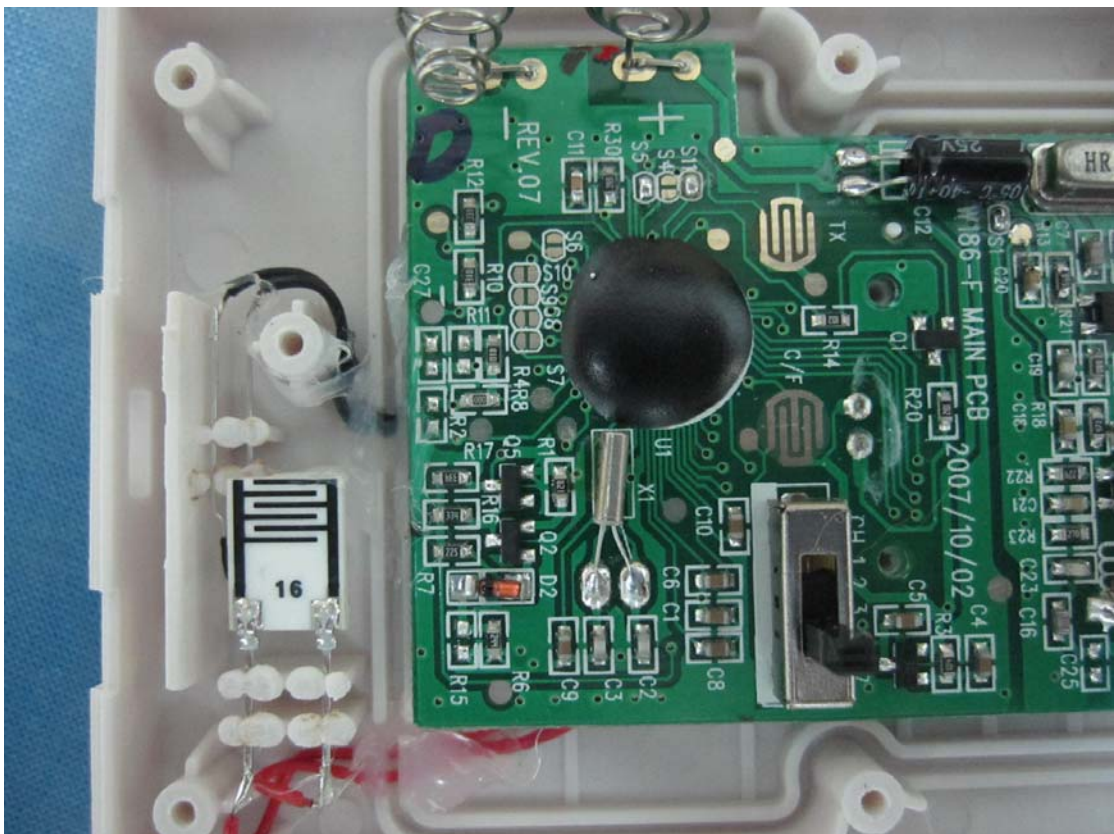

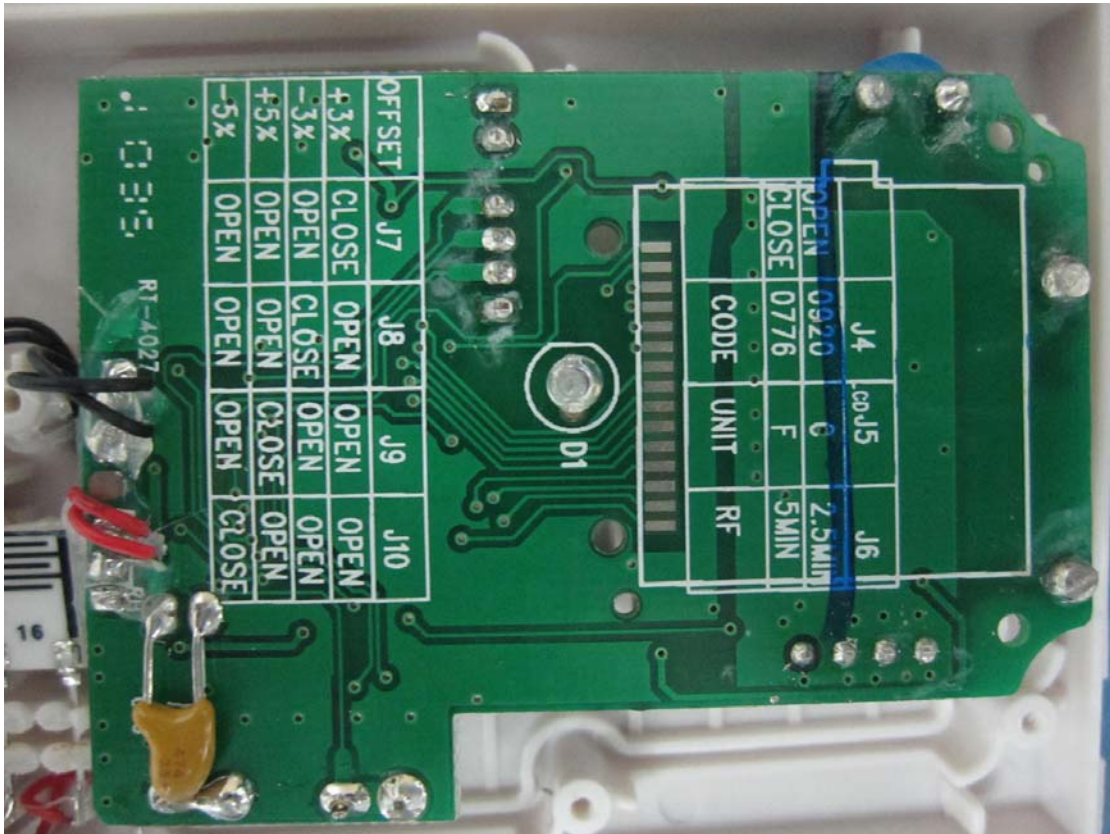

.....End of Report.....