

TEST REPORT #100799

STANDARD: FCC PART 15

**SUBPART B--UNINTENTIONAL RADIATORS
SECTION 15.109 RADIATION EMISSION LIMITS**

EQUIPMENT TESTED:

LACROSSE TECHNOLOGY, LTD.

MODEL: HFS 301-WS RECEIVER

TEST DATE: 10 JULY 1999

1100 Falcon Avenue
Glencoe, MN 55336

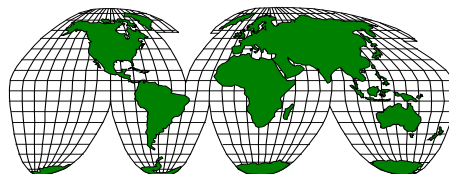

INTERNATIONAL

CERTIFICATION SERVICES, INC.

Tele: 320-864-4444
Fax: 320-864-6611

Prepared for: LaCrosse Technology, Ltd.
1116 South Oak Street
LaCrescent, MN 55447

Test agent: International Certification Services, Inc.
1100 Falcon Avenue
Glencoe, MN 55336
Tele: 320-864-4444
Fax: 320-864-6611

Test location: International Certification Services, Inc.
1100 Falcon Avenue
Glencoe, MN 55336
Tele: 320-864-4444
Fax: 320-864-6611

Prepared by: International Certification Services, Inc.
1100 Falcon Avenue
Glencoe, MN 55336

International Certification Services represents to the client that testing is done in accordance with standard procedures applicable and that reported test results are accurate within generally accepted commercial ranges of accuracy.

This report only applies to the specific samples tested under stated test conditions. It is the manufacturer's responsibility to assure that additional production units of this model are manufactured with identical electrical and mechanical components. International Certification Services shall have no liability for any deductions, inferences or generalizations drawn by the client or others from this report.

This report is the confidential property of the client. As a mutual protection to our clients, the public and ourselves, extracts from the test report shall not be reproduced except in full without our written approval.

INTERNATIONAL



CERTIFICATION SERVICES, INC.

1.0 TEST SUMMARY

TEST REPORT: #100799

COMPANY: LaCrosse Technology, Ltd.

AGENT: International Certification Services, Inc.

PHONE: 320-864-4444

TEST DATE: 10 July, 1999

EQUIPMENT UNDER TEST: 433.92 Mhz Superregenerative receiver

GENERAL TEST SUMMARY: The testing was performed at International Certification Services, Inc. at 1100 Falcon Ave, Glencoe, MN 55336

VERIFICATION / CERTIFICATION STATUS: The 433.92 Mhz Superregenerative receiver was found to be in compliance with the FCC Part 15 Subpart B, Section 15.109 requirements.

MODIFICATIONS NECESSARY: None

TESTED BY

Gerald Heinen

WRITTEN BY

Duane R. Bagdons

2.0 Applicable Standards

INTERNATIONAL



CERTIFICATION SERVICES, INC.

47 CFR Ch.1 (10-1-98 Edition)
 FCC Part 15 Radio Frequency Devices
 Subpart B Unintentional Radiators
 Section 15.109 Radiated Emission Limits

2.1 Referenced Standards

ANSI C63.4-1992 Methods of Measurement of Radio-Noise Emissions from Low-Voltage Electrical and Electronic Equipment in the Range of 9 Khz to 40 Ghz.

2.2 Equipment Units Tested

The equipment tested was a battery powered 433.92 Mhz super regenerative receiver. This subassembly is used in various products. The antenna is a permanent component and is part of the internal PC board assembly.

2.3 Equipment and Cable Configuration

See photos of the EUT pc board and schematic and test configuration setup in Attachment A

2.4 List of Test Equipment

| <u>Test Equipment</u> | <u>Model</u> | <u>S/N</u> | <u>Calibration Date</u> |
|-------------------------------------|------------------------------|------------|-------------------------|
| Spectrum Analyzer | Hewlett-Packard 8566B | 2421A00458 | 3/10/99 |
| Preamp | MiniCircuits ZKL-2R7 | N/A | 6/1/99 |
| Biconical Antenna | AH Systems Model SAS-200/540 | 328 | 6/16/99 |
| Log Periodic Antenna (200-1000 MHz) | EMCO 3146 | 9111-3280 | 6/16/99 |
| Horn Antenna (1-18 Ghz) | EMCO 3115 | 5697 | 3/5/99 |

Measurement cable losses, and antenna correction factors are included in the data sheets. Average detection methods were used in the measurements. The Resolution BW was set at 1 Mhz and the Video BW was set at 1 Hz with a Span of 0 Hz to perform the correct average detected measurements.

2.5 Units of Measurement.

All measurements were taken in dBuV/m with the antenna located at 3 meters distance from the EUT. Frequency measurements are recorded in Mhz

2.6 Location of Test Site

The open area test site (OATS) measurement facility used to collect the data was International Certification Services, Inc. at 1100 Falcon Ave in Glencoe, MN 55336. This

INTERNATIONAL



CERTIFICATION SERVICES, INC.

site has been certified to be in spec of the normalized site attenuation per ANSI C63.4-1992. See letter of compliance from FCC dated July 23, 1998. (FCC 31040/SIT 1300F2)

2.7 Measurement Procedures

A driving signal was induced into the receiver by using a stick antenna driven by a signal generator. The generator was tuned to 433.92 Mhz and the output amplitude was set to a very low level (-30 dBm) just enough to excite the receiver. Receiver activity was monitored with an oscilloscope.

The receiving antenna was placed at a distance of 3 meters from the EUT. The EUT was set on an insulating table in the OATS site and rotated through 360 degrees to determine the worst case EUT orientation. The antenna was then positioned vertical and horizontal to determine which antenna polarity orientation was worst case. Then certification data was recorded at all the frequencies from the fundamental to the 10th harmonic at an antenna height variation of from 1-4 meters.

2.8 Reporting Measurement Data

See data sheets and plots in Attachment B.

2.9 Radiated Emissions Data

The frequency and amplitude of the tuned frequency of the EUT along with the frequencies and amplitudes of the harmonics up to the 7th harmonic are reported in the data sheets in Attachment B. This information is plotted against the limit of section 15.231 of FCC Part 15 subpart B. The polarization of the antenna for each measurement is also recorded.

The Final Level, expressed in dBuV/m, is arrived at by taking the reading from the spectrum analyzer (Level dBuV) and adding the antenna correction factor and cable loss factor (Factor dB) and subtracting the preamp gain. This result then has the FCC limit subtracted from it to provide the margin which gives the tabular data as shown in the data sheets in Attachment B.

Example:

| | | | | | | | | | | |
|------------------|--|---------------|---|---------------|---|------------------|---|------------------|---|---------------|
| <u>Frequency</u> | | <u>Level</u> | + | <u>Factor</u> | = | <u>Corr Data</u> | - | <u>FCC Limit</u> | = | <u>Margin</u> |
| <u>(MHz)</u> | | <u>(dBuV)</u> | + | <u>(dB)</u> | = | <u>(dBuV/m)</u> | - | <u>(dBuV/m)</u> | = | <u>(dB)</u> |
| 100.0 | | 20.6 | + | 11.0 | = | 31.6 | - | 43.5 | = | -11.9 |

2.10 Operating Frequency Data for Intentional Radiators

All operating frequencies and harmonic frequencies and ambient temperature at which all data was taken at is recorded in the data sheets in Attachment B.

2.11 Summary of Results

INTERNATIONAL



CERTIFICATION SERVICES, INC.

The EUT passed the requirements of FCC Part 15 Subpart B, Section 15.109 with a minimum passing margin of -8.2109 dBuV/m at 437.166 Mhz. No modifications were necessary to accomplish this compliance.

INTERNATIONAL



CERTIFICATION SERVICES, INC.

ATTACHMENT A

RADIATED MEASUREMENT SCHEMATIC AND PHOTOS

INTERNATIONAL



CERTIFICATION SERVICES, INC.

Model: HFS 301-WS 433.92 Mhz Receiver Electrical Schematic

| | | |
|------------|--|---------------------------|
| ELV | Item: HFS 301-WS Part Number: 31029 | Page: 3/7 Version: 1.1 |
| | Assembly, Calibration and Test Documentation | Date: 03.04.98 |

3 Schematic Diagram

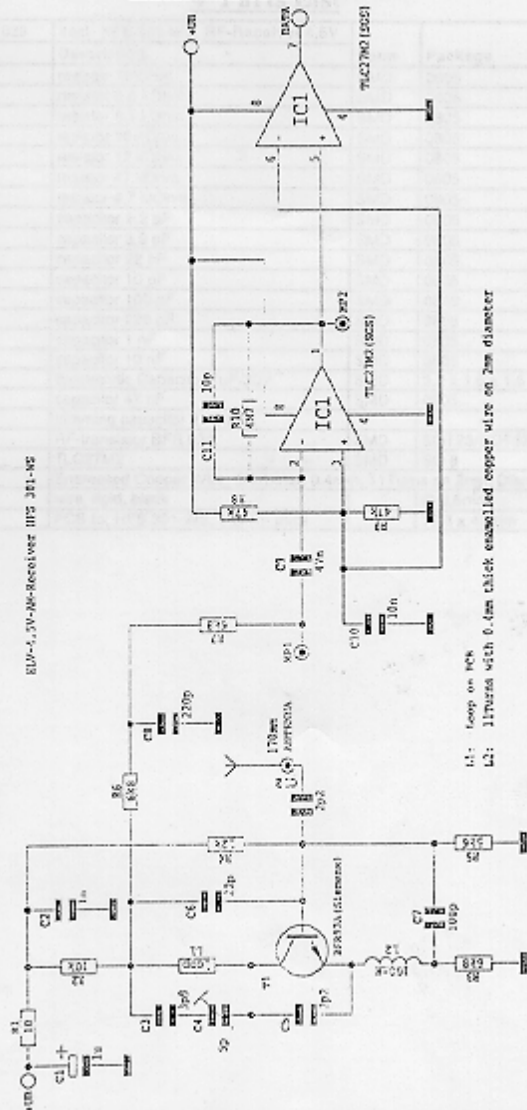

L1: Loop on PCB
L2: 11turns with 0.1mm thick enamelled copper wire on 2mm diameter

| | | | |
|-----------------------|----------------------------|-----------------------------|---------------------------|
| prepared/checked | appr. by managing director | appr. by technical director | appr. by development dir. |
| <i>Delib</i> | | <i>[Signature]</i> | <i>[Signature]</i> |
| Date: <i>03.04.98</i> | Date: | Date: <i>8.4.98</i> | Date: <i>3.4.98</i> |

INTERNATIONAL



CERTIFICATION SERVICES, INC.

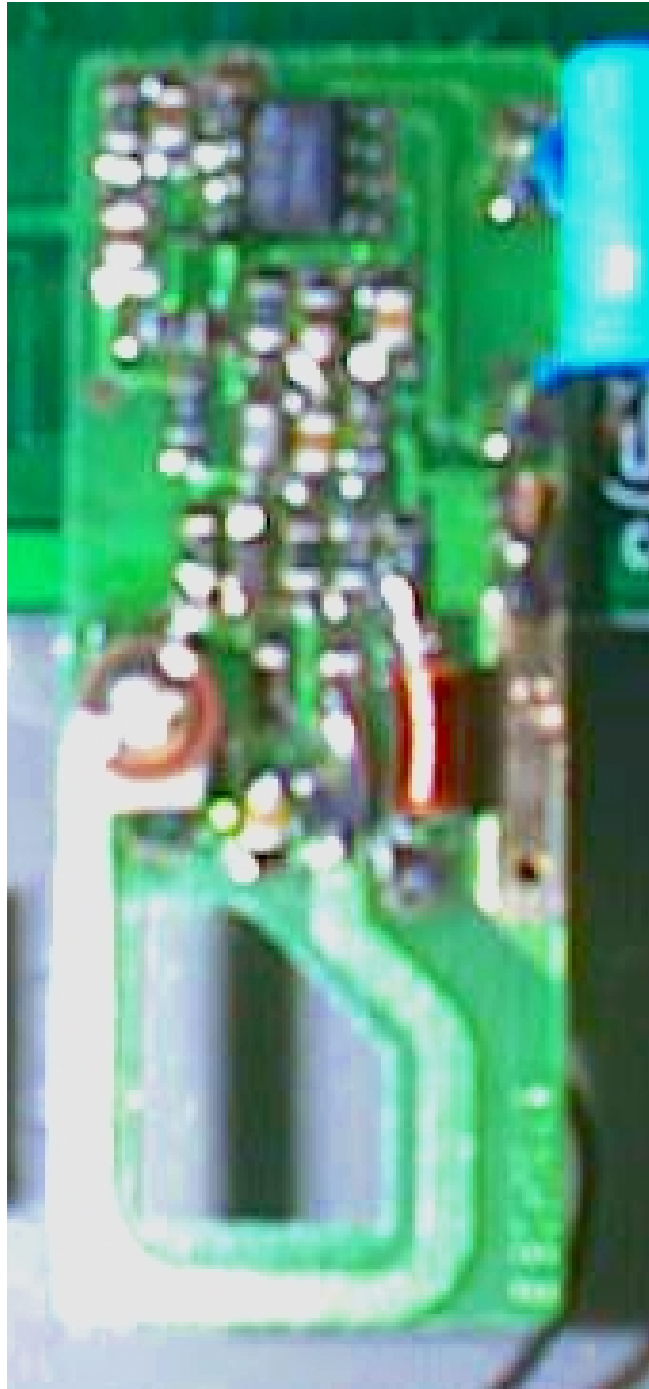

HFS 301-WS (433.92 Mhz) Receiver PC Board

INTERNATIONAL



CERTIFICATION SERVICES, INC.

ATTACHMENT B

DETAILED TEST DATA SHEETS

Each radiated emissions plot indicates the receiving antenna measurement distance in meters and the emission amplitudes with respect to their applicable limits. The associated tabulation for each radiated plot lists the emission frequency, the final emission level, and the margin from the limit.

INTERNATIONAL



CERTIFICATION SERVICES, INC.

LaCrosse Technology, Ltd.
 Model: HFS 301-WS 433.92 Mhz Receiver
 Temperature: 80 Deg F.
 Humidity: 66 % R.H.

Test Technician: Gerald Heinen

Center Frequency: 433.92 Mhz

Preliminary tests were performed on antenna polarities of Vertical and Horizontal. Horizontal was the worst case so all data was taken with an antenna polarity of Horizontal.

Initial testing was performed in the anechoic shield room to determine if there were any other spurious emissions other than the fundamental and its harmonics. No other emissions were found.

Certification testing was performed at the OATS site with an antenna distance of 3 meters and the EUT at 90 Degrees to the antenna.

The limit for section 15.109 is 100 uV/m from 30-88 Mhz, 150 uV/m from 88-216, 200 uV/m from 216-960 Mhz and 500 uV/m above 960 Mhz. All data is taken with the required Quasi-Peak Detector. This converted to dBuV is the limit shown in the next table.

| Freq (Mhz) | Quasi-Peak Det dBuV/m | Ant Corr Fac | Cable Corr Fac | Corr Data | 15.109 Limit dBuV/m | Margin |
|------------|-----------------------|--------------|----------------|-----------|---------------------|---------|
| 404.915 | 27.7 | 15.4983 | 4.1599 | 25.3582 | 46.02 | -20.662 |
| 406.50507 | 30 | 15.5301 | 4.17638 | 27.7065 | 46.02 | -18.314 |
| 408.18513 | 30.4 | 15.5637 | 4.19379 | 28.1575 | 46.02 | -17.863 |
| 409.77518 | 30.95 | 15.5955 | 4.21026 | 28.7558 | 46.02 | -17.264 |
| 411.39523 | 31.25 | 15.6419 | 4.22705 | 29.1189 | 46.02 | -16.901 |
| 413.04529 | 31.6 | 15.6914 | 4.24415 | 29.5355 | 46.02 | -16.484 |
| 414.66534 | 31.75 | 15.74 | 4.26094 | 29.7509 | 46.02 | -16.269 |
| 416.25539 | 31.8 | 15.7877 | 4.27742 | 29.8651 | 46.02 | -16.155 |
| 417.84545 | 32.2 | 15.8354 | 4.2939 | 30.3293 | 46.02 | -15.691 |
| 419.49551 | 32.55 | 15.8849 | 4.311 | 30.7459 | 46.02 | -15.274 |
| 421.085 | 32.75 | 15.9217 | 4.32747 | 30.9992 | 46.02 | -15.021 |
| 422.67506 | 32.4 | 15.9535 | 4.34395 | 30.6975 | 46.02 | -15.323 |
| 424.29511 | 31.6 | 15.9859 | 4.36074 | 29.9466 | 46.02 | -16.073 |
| 425.91516 | 29.8 | 16.0183 | 4.37753 | 28.1958 | 46.02 | -17.824 |
| 427.53522 | 27.45 | 16.0507 | 4.39432 | 25.895 | 46.02 | -20.125 |
| | | | | | | |
| Freq (Mhz) | Quasi-Peak Det | Ant Corr | Cable Corr | Corr Data | 15.109 Limit | Margin |

INTERNATIONAL



CERTIFICATION SERVICES, INC.

| | dBuV/m | Fac | Fac | | dBuV/m | |
|------------------|-----------|---------------|----------------|----------------|--------------|----------------|
| 430.74533 | 29.65 | 16.1224 | 4.42758 | 28.1999 | 46.02 | -17.82 |
| 432.33538 | 33.75 | 16.1701 | 4.44406 | 32.3641 | 46.02 | -13.656 |
| 433.95543 | 45.9 | 16.2187 | 4.46085 | 44.5795 | 46.02 | -1.4405 |
| 435.54549 | 38.45 | 16.2664 | 4.47733 | 37.1937 | 46.02 | -8.8263 |
| 437.16576 | 39 | 16.315 | 4.49412 | 37.8091 | 46.02 | -8.2109 |
| 438.78549 | 38.45 | 16.3636 | 4.5109 | 37.3245 | 46.02 | -8.6955 |
| 440.37576 | 36.65 | 16.4113 | 4.52739 | 35.5887 | 46.02 | -10.431 |
| 441.99548 | 34.2 | 16.4599 | 4.54417 | 33.204 | 46.02 | -12.816 |
| 443.58575 | 32.25 | 16.5076 | 4.56065 | 31.3182 | 46.02 | -14.702 |
| 445.17548 | 32.3 | 16.5553 | 4.57713 | 31.4324 | 46.02 | -14.588 |
| 446.82569 | 33.4 | 16.6048 | 4.59423 | 32.599 | 46.02 | -13.421 |
| 448.40008 | 34.05 | 16.652 | 4.61054 | 33.3125 | 46.02 | -12.707 |
| 450.02013 | 34.3 | 16.7004 | 4.62733 | 33.6277 | 46.02 | -12.392 |
| 451.64019 | 34.3 | 16.7328 | 4.64412 | 33.6769 | 46.02 | -12.343 |
| 453.26024 | 34.45 | 16.7652 | 4.66091 | 33.8761 | 46.02 | -12.144 |
| 454.79029 | 33.6 | 16.7958 | 4.67677 | 33.0726 | 46.02 | -12.947 |
| 456.50035 | 33.4 | 16.83 | 4.69449 | 32.9245 | 46.02 | -13.096 |
| 458.0904 | 32.7 | 16.8618 | 4.71097 | 32.2728 | 46.02 | -13.747 |
| 459.77046 | 32.45 | 16.8954 | 4.72838 | 32.0738 | 46.02 | -13.946 |
| 461.36057 | 32.1 | 16.968 | 4.74486 | 31.8129 | 46.02 | -14.207 |
| 462.98008 | 31.55 | 17.049 | 4.76164 | 31.3606 | 46.02 | -14.659 |

Signal
Generator
Output signal

INTERNATIONAL



CERTIFICATION SERVICES, INC.

HFS 301-WS 433.92 Mhz Receiver

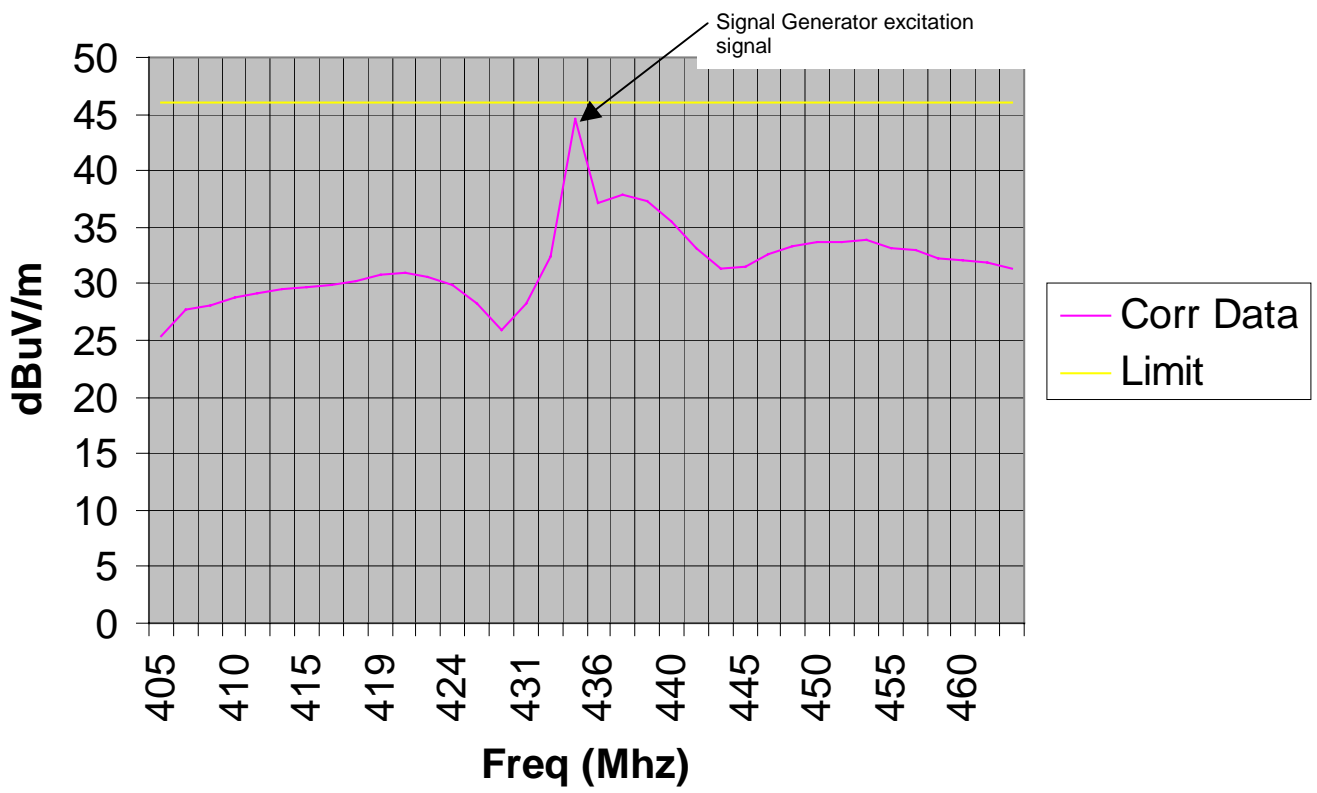

INTERNATIONAL



CERTIFICATION SERVICES, INC.

ATTACHMENT C

**PRODUCT DATA SHEET OR PRODUCT INFORMATION FORM AS SUPPLIED
BY THE CUSTOMER**

INTERNATIONAL



CERTIFICATION SERVICES, INC.

COMPANY NAME: LaCrosse Technology, Ltd.

CUSTOMER REPRESENTATIVE: International Certification Services, Inc.

EQUIPMENT DESCRIPTION: 433.92 Mhz Super-regenerative Receiver

MODEL NUMBER: HFS 301-WS

SERIAL NUMBER: Engineering Unit

TYPE OF TEST: _____ Development
_____ Initial Design Verification
_____ Design Change (Please describe exact changes below)
 X Production Sample (Audit Test)

Changes made: NONE

OSCILLATOR FREQUENCIES:

NONE

PRODUCT SHIELDING PROVISION:

Plastic enclosure

SOFTWARE AND / OR OPERATING MODES:

NONE

I/O CABLES: NONE

INTERNATIONAL



CERTIFICATION SERVICES, INC.