





FCC CERTIFICATION TEST REPORT

Applicant:	iFIT Health and Fitness, Inc.		
Address:	1500 S 1000 W, Logan, Utah 84321, United States		
Manufacturer:	Guangzhou Yuandong Smart Sports Technology Co., Ltd.		
Address:	Room 518, No. 198, Kezhu Road, Huangpu District, Guangzhou		
Product Description:	Tablet		
Brand Name:	iFIT		
Tested Model:	MP24-Xenon-V; MP16-Xenon-V; MP10-Xenon-V		
FCC ID:	OMC453584V		
Report No.:	JCF240131021-004		
Received Date:	Jan. 31, 2024		
Tested Date:	Jan. 31, 2024 ~ Mar. 07, 2024		
Issued Date:	Mar. 07, 2024		
Test Standards:	FCC Rules and Regulations Part 15 Subpart E,		
Test Procedure:	ANSI C63.10:2013, 789033 D02 General U-NII Test Procedures New Rules v02r01, 662911 D01 Multiple Transmitter Output v02r01		
Test Result:	Pass		
Prepared By:			
			
<u>Roger Li/Engineer</u>		Date: Mar. 07, 2024	
Reviewed By:			
			
<u>Kennys Zhang/Engineer</u>		Date: Mar. 07, 2024	
			
Approved By:			
			
<u>Talent Zhang/Engineer</u>		Date: Mar. 07, 2024	

Note: The test results in this report apply exclusively to the tested model / sample. Without written approval of Guangzhou Jingce Testing Technology Co., Ltd. the test report shall not be reproduced except in full.

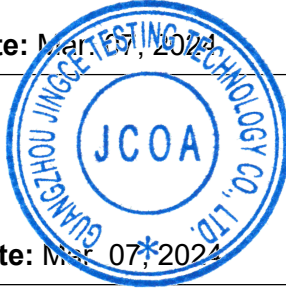
Report Revise Record

Report Version	Revise Time	Issued Date	Valid Version	Notes
V1.0	/	Mar. 07, 2024	Original Report	/

Table of Contents

1. Test Report Declare	5
2. Summary of test results	6
3. Test Laboratory	6
4. Equipment Under Test	7
4.1. Description of EUT	7
4.2. Channel List	7
4.3. Test Channel Configuration	9
4.4. Test Environment Conditions	10
4.5. The Worse Case Power Setting Parameter	10
4.6. Description of Available Antennas	12
5. Description of Test Setup	12
5.1. Accessory	12
5.2. Support Equipment	12
5.3. Test Setup	12
5.4. Setup Diagram for Tests	12
6. Measurement uncertainty	13
7. Measuring Instrument and Software Used	13
8. Duty Cycle	15
8.1. Block Diagram of Test Setup	15
8.2. Limits	15
8.3. Procedure	15
8.4. Results	15
8.5. Original Test Data	18
9. 26dB Bandwidth and 6dB Bandwidth	62
9.1. Block Diagram of Test Setup	62
9.2. Limits	62
9.3. Test Procedure	62
9.4. Test Result	62
9.5. Original Test Data	68
10. Maximum Output Power	165
10.1. Block Diagram of Test Setup	165
10.2. Limits	165
10.3. Test Procedure	165
10.4. Test Result	165
11. Power Spectral Density	169
11.1. Block Diagram of Test Setup	169
11.2. Limits	169
11.3. Test Procedure	169
11.4. Test Result	170
11.5. Original Test Data	173
12. Frequency Stability Measurement	221
12.1. Block Diagram of Test Setup	221
12.2. Limit of Frequency Stability	221
12.3. Test Procedures	221
12.4. Test Result	221
13. Radiated Emission	225
13.1. Block Diagram of Test Setup	225
13.2. Limit	226
13.3. Test Procedure	227
13.4. Test Result	229
13.5. Original Test Data	229
14. AC Power Line Conducted Emissions	238

14.1. Block Diagram of Test Setup	238
14.2. Limits	238
14.3. Test Procedure	238
14.4. Test Result	239
14.5. Original Test Data	239
15. Dynamic Frequency Selection	240
15.1. Applicability of DFS Requirements	240
15.2. Limit	241
15.3. Parameters of Radar Test Waveform	241
15.4. Calibration of Radar Waveform	242
15.5. Channel Closing Transmission Time, Channel Move Time and Non-Occupancy Period	244
15.6. Test Setup	244
15.7. Test Result	244
15.8. Original Test Data	245
16. Antenna Requirements	247
16.1. Applicable Requirements	247
16.2. Result	247
APPENDIX A - Radiated Emission Below 1GHz Test Data	248
APPENDIX B - Radiated Emission Above 1GHz Test Data	254
APPENDIX C - AC Power Line Conducted Emission Test Data	470

1. Test Report Declare

Applicant:	iFIT Health and Fitness, Inc.
Address:	1500 S 1000 W, Logan, Utah 84321, United States
Manufacturer:	Guangzhou Yuandong Smart Sports Technology Co., Ltd.
Address:	Room 518, No. 198, Kezhu Road, Huangpu District, Guangzhou
Product Name:	Tablet
Brand Name:	iFIT
Model Name:	MP24-Xenon-V; MP16-Xenon-V; MP10-Xenon-V
Difference Description:	The three size variants of the product only differ in appearance, dimensions, and display circuitry, while everything else remains the same. All models share the same main chip and RF hardware, including modules, crystal oscillators, antennas, etc., and have identical functionality.

We Declare:

The equipment described above is tested by Guangzhou Jingce Testing Technology Co., Ltd. and in the configuration tested the equipment complied with the standards specified above. The test results are contained in this test report and Guangzhou Jingce Testing Technology Co., Ltd. is assumed of full responsibility for the accuracy and completeness of these tests except as provided information by clients.

2. Summary of test results

The EUT have been tested according to the applicable standards as referenced below.			
Clause	Description of Test Item	Standard	Verdict
1	6/26dB Bandwidth	FCC 15.407 (a)&(e)	Pass
2	Maximum Conducted Output Power	FCC 15.407 (a)	Pass
3	Power Spectral Density	FCC 15.407 (a)	Pass
4	Frequency Stability Measurement	FCC 15.407 (g)	Pass
5	Radiated Band edge and Spurious Emission	FCC 15.407 (b) FCC 15.209 FCC 15.205	Pass
6	Power Line Conducted Emission	FCC 15.207	Pass
7	Antenna requirement	FCC 15.203	Pass
8	Dynamic Frequency Selection	FCC 15.407 (h)	Pass

Note: The model: MP24-Xenon-V; MP16-Xenon-V; MP10-Xenon-V share the same main chip and RF hardware, including modules, crystal oscillators, antennas, etc., and have identical functionality. So except for item 5&6 above, which requires all models to be tested, the remaining items only test model MP24-Xenon-V.

3. Test Laboratory

Guangzhou Jingce Testing Technology Co., Ltd.

Add.: No.10, Hefeng No.1 street, Huangpu District, Guangzhou, Guangdong, People's Republic of China

Association for Laboratory Accreditation(A2LA). Certificate Number: 6594.03

FCC Designation Number: CN1381. Test Firm Registration Number: 486550

IC Test Firm Registration Number: 31808

Conformity Assessment Body identifier: CN0173

4. Equipment Under Test

4.1. Description of EUT

EUT Name:	Tablet
Model Number:	MP24-Xenon-V; MP16-Xenon-V; MP10-Xenon-V
EUT Function Description:	Refer to user manual
Power Supply:	DC 12V 3A
Hardware Version:	N/A
Software Version:	N/A
Radio Specification:	IEEE 802.11a/n/ac
Operation Frequency:	IEEE 802.11a: 5180MHz—5825MHz IEEE 802.11n HT20: 5180MHz—5825MHz IEEE 802.11n HT40: 5190MHz—5795MHz IEEE 802.11ac VHT20: 5180MHz—5825MHz IEEE 802.11ac VHT40: 5190MHz—5795MHz IEEE 802.11ac VHT80: 5210MHz—5775MHz
Modulation:	IEEE 802.11a: OFDM (64QAM, 16QAM, QPSK, BPSK) IEEE 802.11n HT20, HT40: OFDM (64QAM, 16QAM, QPSK, BPSK) IEEE 802.11ac (VHT20/40/80): OFDM (256QAM, 64QAM, 16QAM, QPSK, BPSK)
Data Rate:	IEEE 802.11a: 6, 9, 12, 18, 24, 36, 48, 54Mbps IEEE 802.11n HT20: 14.4, 28.9, 43.3, 57.8, 86.7, 115.6, 130, 144.4 Mbps IEEE 802.11n HT40: 30, 60, 90, 120, 180, 240, 270, 300 Mbps IEEE 802.11ac VHT20: 14.4, 28.9, 43.3, 57.8, 86.7, 115.6, 130, 144.4, 173.3 Mbps IEEE 802.11ac VHT40: 30, 60, 90, 120, 180, 240, 270, 300, 360, 400 Mbps IEEE 802.11ac VHT80: 65, 130, 195, 260, 390, 520, 585, 650, 780, 866.7 Mbps
Antenna Type:	FPC Antenna, MAX. Gain: 5.83 dBi

Antenna Gain:		
MP10-Xenon-V	BT ANT	2.4G: 3.14dBi
	WIFI ANT 1	2.4G: 2.67dBi; 5G: 2.89dBi
	WIFI ANT 2	2.4G: 1.96dBi; 5G: 1.37dBi
MP16-Xenon-V	BT ANT	2.4G: 4.90dBi
	WIFI ANT 1	2.4G: 3.90dBi; 5G: 3.81dBi
	WIFI ANT 2	2.4G: 4.55dBi; 5G: 3.27dBi
MP24-Xenon-V	BT ANT	2.4G: 5.16dBi
	WIFI ANT 1	2.4G: 4.81dBi; 5G: 4.37dBi
	WIFI ANT 2	2.4G: 4.39dBi; 5G: 5.83dBi

Note 1: EUT is the ab. of equipment under test.

Note 2: The antenna gain is declared by the customer and the laboratory is not responsible for the accuracy of the antenna gain.

4.2. Channel List

UNII-1 (For Bandwidth = 20 MHz)		UNII-1 (For Bandwidth = 40 MHz)	
Channel	Frequency (MHz)	Channel	Frequency (MHz)
36	5180	38	5190
40	5200	46	5230
44	5220	/	/

48	5240	/	/
UNII-1 (For Bandwidth = 80 MHz)			
Channel		Frequency (MHz)	
42		5210	

UNII-2A (For Bandwidth = 20 MHz)		UNII-2A (For Bandwidth = 40 MHz)	
Channel	Frequency (MHz)	Channel	Frequency (MHz)
52	5260	54	5270
56	5280	62	5310
60	5300	/	/
64	5320	/	/
UNII-2A (For Bandwidth = 80 MHz)			
Channel		Frequency (MHz)	
58		5290	

UNII-2C (For Bandwidth = 20 MHz)		UNII-2C (For Bandwidth = 40 MHz)	
Channel	Frequency (MHz)	Channel	Frequency (MHz)
100	5500	102	5510
104	5520	110	5550
108	5540	118	5590
112	5560	126	5630
116	5580	134	5670
120	5600	142	5710
124	5620	/	/
128	5640	/	/
132	5660	/	/
136	5680	/	/
140	5700	/	/
144	5720	/	/
UNII-2C (For Bandwidth = 80 MHz)			
Channel		Frequency (MHz)	
106		5530	

122	5610
138	5690

UNII-3 (For Bandwidth = 20 MHz)		UNII-3 (For Bandwidth = 40 MHz)	
Channel	Frequency (MHz)	Channel	Frequency (MHz)
149	5745	151	5755
153	5765	159	5795
157	5785	/	/
161	5805	/	/
165	5825	/	/
UNII-3 (For Bandwidth = 80 MHz)			
Channel		Frequency (MHz)	
155		5775	

4.3. Test Channel Configuration

Mode	Data rate (Mbps) (see Note)	Test Channel and Frequency
802.11a TX Mode	6	CH36, 5180
	6	CH44, 5220
	6	CH48, 5240
	6	CH52, 5260
	6	CH60, 5300
	6	CH64, 5320
	6	CH100, 5500
	6	CH116, 5580
	6	CH140, 5700
	6	CH144, 5720
	6	CH149, 5745
	6	CH157, 5785
	6	CH165, 5825
802.11n HT20 TX Mode	MCS 8	CH36, 5180
	MCS 8	CH44, 5220
	MCS 8	CH48, 5240
	MCS 8	CH52, 5260
	MCS 8	CH60, 5300
	MCS 8	CH64, 5320
	MCS 8	CH100, 5500
	MCS 8	CH116, 5580
	MCS 8	CH140, 5700
	MCS 8	CH144, 5720
	MCS 8	CH149, 5745
	MCS 8	CH157, 5785
	MCS 8	CH165, 5825
802.11n HT40 TX Mode	MCS 8	CH38, 5190
	MCS 8	CH46, 5230
	MCS 8	CH54, 5270
	MCS 8	CH62, 5310

	MCS 8	CH102, 5510
	MCS 8	CH110, 5550
	MCS 8	CH134, 5670
	MCS 8	CH142, 5710
	MCS 8	CH151, 5755
	MCS 8	CH159, 5795
802.11ac VHT20 TX Mode	MCS 0	CH36, 5180
	MCS 0	CH44, 5220
	MCS 0	CH48, 5240
	MCS 0	CH52, 5260
	MCS 0	CH60, 5300
	MCS 0	CH64, 5320
	MCS 0	CH100, 5500
	MCS 0	CH116, 5580
	MCS 0	CH140, 5700
	MCS 0	CH140, 5720
	MCS 0	CH149, 5745
	MCS 0	CH157, 5785
802.11ac VHT40 TX Mode	MCS 0	CH38, 5190
	MCS 0	CH46, 5230
	MCS 0	CH54, 5270
	MCS 0	CH62, 5310
	MCS 0	CH102, 5510
	MCS 0	CH110, 5550
	MCS 0	CH134, 5670
	MCS 0	CH142, 5710
	MCS 0	CH151, 5755
802.11ac VHT80 TX Mode	MCS 0	CH159, 5795
	MCS 0	CH42, 5210
	MCS 0	CH58, 5290
	MCS 0	CH106, 5530
	MCS 0	CH122, 5610
	MCS 0	CH138, 5690
	MCS 0	CH155, 5775

Note: According exploratory test, EUT will have maximum output power in those data rate, so those data rate were used for all test.

4.4. Test Environment Conditions

During the measurement the environmental conditions were within the listed ranges:

	Normal Conditions	Extreme Conditions
Temperature range	21-25 °C	0 °C to +40 °C
Humidity range	40-75%	N/A
Pressure range	86-106 kPa	N/A
Power supply	NV: DC 12V from Adapter	N/A

Note: The Extreme temperature range and extreme voltages are declared by the manufacturer.

4.5. The Worse Case Power Setting Parameter

The Worse Case Power Setting Parameter			
Test Software	Adb instruction		
Mode	Channel	Soft set value	
		ANT0	ANT1
802.11a	36	Default	13
	44	Default	13
	48	Default	Default

	52	Default	Default
	60	Default	Default
	64	Default	Default
	100	Default	Default
	116	Default	Default
	140	Default	13
	144	Default	Default
	149	Default	Default
	157	Default	Default
	165	Default	Default
802.11n HT20	36	12	12
	44	12	12
	48	13	13
	52	14	14
	60	13	13
	64	13	13
	100	14	14
	116	14	14
	140	14	14
	144	Default	Default
	149	16	16
	157	16	16
165	16	16	
802.11n HT40	38	Default	Default
	46	Default	Default
	54	Default	Default
	62	Default	Default
	102	Default	Default
	110	Default	Default
	134	12	12
	142	Default	Default
	151	Default	Default
	159	Default	Default
802.11ac VHT20	36	12	12
	44	12	12
	48	Default	Default
	52	Default	Default
	60	Default	Default
	64	14	14
	100	Default	Default
	116	12	12
	140	Default	Default
	144	Default	Default
	149	Default	Default
	157	Default	Default
165	Default	Default	
802.11ac VHT40	38	Default	Default
	46	Default	Default
	54	Default	Default
	62	Default	Default
	102	14	14
	110	Default	Default
	134	12	12
	144	Default	Default
	151	Default	Default
	159	Default	Default
802.11ac VHT80	42	10	10
	58	14	14
	106	12	12
	122	14	14

	138	14	14
	155	14	14

4.6. Description of Available Antennas

Test Mode	Transmit and Receive Mode	Description
802.11a	☒ 2TX, 2RX	ANT 1 and ANT2 can be used as transmitting/receiving antenna.
802.11n HT20	☒ 2TX, 2RX	ANT 1 and ANT2 can be used as transmitting/receiving antenna.
802.11n HT40	☒ 2TX, 2RX	ANT 1 and ANT2 can be used as transmitting/receiving antenna.
802.11ac VHT20	☒ 2TX, 2RX	ANT 1 and ANT2 can be used as transmitting/receiving antenna.
802.11ac VHT40	☒ 2TX, 2RX	ANT 1 and ANT2 can be used as transmitting/receiving antenna.
802.11ac VHT80	☒ 2TX, 2RX	ANT 1 and ANT2 can be used as transmitting/receiving antenna.

5. Description of Test Setup

5.1. Accessory

Description of Accessories	Manufacturer	Model Number	Description	Remark
/	/	/	/	/

5.2. Support Equipment

Equipment	Brand Name	Model Name	P/N
PC	Lenovo	T480	/
Adapter	SOY	SOY-1200300	/

5.3. Test Setup

The EUT can work in Fixed Frequency mode.

5.4. Setup Diagram for Tests



6. Measurement uncertainty

Test Item	Uncertainty
AC Power Conduction emission	1.37 dB
All Radiated emissions	5.4dB
Conducted emissions	3.09 dB
Occupied Channel Bandwidth	1.1%
Conducted Output power	0.82dB
Power Spectral Density	0.82dB

Note: This uncertainty represents an expanded uncertainty expressed at approximately the 95 % confidence level using a coverage factor of k = 2.

7. Measuring Instrument and Software Used

TS Test System						
Used	Equipment	Manufacturer	Model No.	Serial No.	Last Cal.	Due. Date
<input checked="" type="checkbox"/>	Spectrum Analyzer	Keysight	N9030B	MY56320512	Sep. 12, 2023	Sep. 11, 2024
<input checked="" type="checkbox"/>	Vector Signal Generator	Keysight	N5182B	MY57300334	Sep. 12, 2023	Sep. 11, 2024
<input checked="" type="checkbox"/>	Signal Generator	Keysight	N5171B	MY57280639	Sep. 12, 2023	Sep. 11, 2024
<input checked="" type="checkbox"/>	DC POWER	Keysight	E342A	MY59020356	Jul. 14, 2023	Jul. 13, 2024
<input checked="" type="checkbox"/>	Incubator thermometer	GWS	EL-02JA	21107288	Sep. 12, 2023	Sep. 11, 2024
<input checked="" type="checkbox"/>	Control unit(Power sensor)	Tonscend	JS0806-2	/	Sep. 12, 2023	Sep. 11, 2024
<input checked="" type="checkbox"/>	Wideband radio communication tester	R&S	CMW500	163478	Jul. 11, 2023	Jul. 10, 2024
<input checked="" type="checkbox"/>	Spectrum Analyzer	Keysight	N9020B	MY60112206	Sep. 12, 2023	Sep. 12, 2024
<input checked="" type="checkbox"/>	Control unit(Power sensor)	Tonscend	JS0806-2	21H8060465	Sep. 12, 2023	Sep. 12, 2024
Software						
Used	Description	Manufacturer	Name	Version		
<input checked="" type="checkbox"/>	Test software	Tonscend	JS1120-3	V3.3.10		
RSE Test System						
Used	Equipment	Manufacturer	Model No.	Serial No.	Last Cal.	Due. Date
<input checked="" type="checkbox"/>	EMI Receiver	R&S	ESW	101685	Jul. 12, 2023	Jul. 11, 2024
<input checked="" type="checkbox"/>	Bilog Antenna	Schwarzbeck	VULB 9163	01416	Mar. 21, 2023	Mar. 20, 2024
<input checked="" type="checkbox"/>	Horn Antenna 1	Schwarzbeck	BBHA 9120 D	02411	May. 25, 2023	May. 24, 2024
<input checked="" type="checkbox"/>	Horn Antenna 2	ETS	BBHA 9170	1090	Sep. 04, 2023	Sep. 03, 2024
<input checked="" type="checkbox"/>	loop-antenna	Schwarzbeck	FMZB 1513-60	00030	Jan. 14, 2024	Jan. 13, 2025
<input checked="" type="checkbox"/>	Signal Pre-Amplifier	Tonscend	TAP01018050	AP21C806122	Jul. 10, 2023	Jul. 09, 2024
<input checked="" type="checkbox"/>	Signal Pre-Amplifier	Tonscend	TAP9K3G32	AP20K806104	Jul. 10, 2023	Jul. 09, 2024
<input checked="" type="checkbox"/>	Signal	ETS	3116C-PA	00217677	Aug. 24, 2023	Aug. 23, 2024

	Pre-Amplifier					
<input checked="" type="checkbox"/>	3m Fully-anechoic Chamber	ETS	RFD-100	/	Apr. 24, 2021	Apr. 23, 2024
Software						
Used	Description	Manufacturer	Name		Version	
<input checked="" type="checkbox"/>	Test software	Tonscend	TS+		V3.0.0.4	
Conducted Emission Test For AC Power Port						
Used	Equipment	Manufacturer	Model No.	Serial No.	Last Cal.	Due. Date
<input checked="" type="checkbox"/>	LISN	R&S	ENV216	102154	Jul. 10, 2023	Jul. 09, 2024
<input checked="" type="checkbox"/>	EMI Receiver	R&S	ESR3	102509	Jul. 12, 2023	Jul. 11, 2024
Software						
Used	Description	Manufacturer	Name		Version	
<input checked="" type="checkbox"/>	Test software	EZ	EZ-EMC		EMEC-3A1	
Other Instrument						
Used	Equipment	Manufacturer	Model No.	Serial No.	Last Cal.	Due. Date
<input checked="" type="checkbox"/>	Temperature & Humidity	Temperature	HTC-1	/	Nov. 02, 2023	Nov. 01, 2024

8. Duty Cycle

8.1. Block Diagram of Test Setup

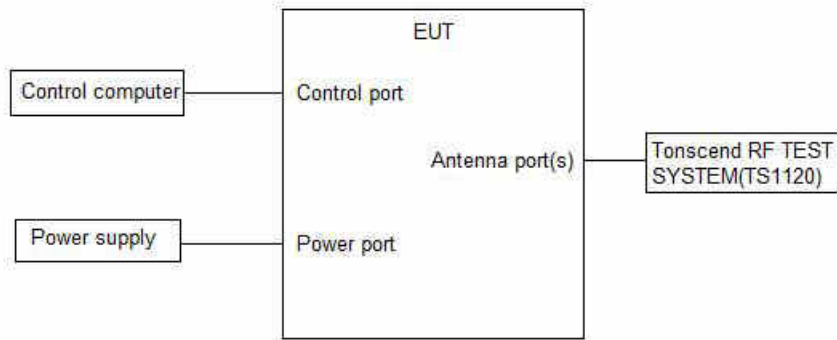

8.2. Limits

None; for reporting purposes only.

8.3. Procedure

Refer to KDB 789033 D02 General U-NII Test Procedures New Rules v02r01 section II.B.

The zero-span mode on a spectrum analyzer or EMI receiver, if the response time and spacing between bins on the sweep are sufficient to permit accurate measurements of the on and off times of the transmitted signal.

Set the center frequency of the instrument to the center frequency of the transmission.

Set RBW \geq EBW if possible; otherwise,

set RBW to the largest available value. Set VBW \geq RBW.

Set detector = peak or average. The zero-span measurement method shall not be used unless both RBW and VBW are $> 50/T$, where T is defined in II.B.1.a), and the number of sweep points across duration T exceeds 100. (For example, if VBW and/or RBW are limited to 3 MHz, then the zero-span method of measuring duty cycle shall not be used if $T \leq 16.7$ microseconds.)

8.4. Results

Test Mode	Ant.	Freq. (MHz)	Transmission Duration (ms)	Transmission Period (ms)	Duty Cycle (%)
11A	Ant1	5180	1.39	1.45	95.86
	Ant2	5180	1.39	1.44	96.53
	Ant1	5200	1.39	1.44	96.53
	Ant2	5200	1.39	1.45	95.86
	Ant1	5240	1.39	1.44	96.53
	Ant2	5240	1.39	1.45	95.86
	Ant1	5260	1.39	1.44	96.53
	Ant2	5260	1.39	1.45	95.86
	Ant1	5280	1.39	1.45	95.86
	Ant2	5280	1.39	1.45	95.86
	Ant1	5320	1.39	1.45	95.86
	Ant2	5320	1.39	1.44	96.53
	Ant1	5500	1.39	1.45	95.86
	Ant2	5500	1.39	1.45	95.86
	Ant1	5580	1.39	1.44	96.53
	Ant2	5580	1.39	1.45	95.86
	Ant1	5700	1.39	1.45	95.86
	Ant2	5700	1.39	1.44	96.53
	Ant1	5720	1.39	1.44	96.53
	Ant2	5720	1.39	1.45	95.86
Ant1	5745	1.39	1.44	96.53	
Ant2	5745	1.39	1.44	96.53	
Ant1	5785	1.39	1.44	96.53	

	Ant2	5785	1.39	1.44	96.53	
	Ant1	5825	1.39	1.45	95.86	
	Ant2	5825	1.39	1.44	96.53	
11N20MIMO	Ant1	5180	1.30	1.36	95.59	
	Ant2	5180	1.30	1.36	95.59	
	Ant1	5200	1.30	1.36	95.59	
	Ant2	5200	1.30	1.35	96.30	
	Ant1	5240	1.30	1.35	96.30	
	Ant2	5240	1.30	1.35	96.30	
	Ant1	5260	1.30	1.35	96.30	
	Ant2	5260	1.30	1.36	95.59	
	Ant1	5280	1.30	1.36	95.59	
	Ant2	5280	1.30	1.36	95.59	
	Ant1	5320	1.30	1.36	95.59	
	Ant2	5320	1.30	1.35	96.30	
	Ant1	5500	1.30	1.35	96.30	
	Ant2	5500	1.30	1.36	95.59	
	Ant1	5580	1.30	1.35	96.30	
	Ant2	5580	1.30	1.35	96.30	
	Ant1	5700	1.30	1.35	96.30	
	Ant2	5700	1.30	1.36	95.59	
	Ant1	5720	1.30	1.35	96.30	
	Ant2	5720	1.30	1.35	96.30	
	Ant1	5745	1.30	1.35	96.30	
	Ant2	5745	1.30	1.35	96.30	
	Ant1	5785	1.30	1.35	96.30	
	Ant2	5785	1.30	1.36	95.59	
	Ant1	5825	1.30	1.36	95.59	
	Ant2	5825	1.30	1.36	95.59	
	11N40MIMO	Ant1	5190	0.65	0.70	92.86
		Ant2	5190	0.65	0.70	92.86
Ant1		5230	0.64	0.70	91.43	
Ant2		5230	0.64	0.70	91.43	
Ant1		5270	0.65	0.70	92.86	
Ant2		5270	0.64	0.70	91.43	
Ant1		5310	0.64	0.70	91.43	
Ant2		5310	0.64	0.70	91.43	
Ant1		5510	0.65	0.70	92.86	
Ant2		5510	0.64	0.70	91.43	
Ant1		5550	0.64	0.70	91.43	
Ant2		5550	0.65	0.70	92.86	
Ant1		5670	0.65	0.70	92.86	
Ant2		5670	0.65	0.70	92.86	
Ant1		5710	0.65	0.70	92.86	
Ant2		5710	0.65	0.70	92.86	
Ant1		5755	0.65	0.70	92.86	
Ant2		5755	0.64	0.70	91.43	
Ant1	5795	0.65	0.70	92.86		
Ant2	5795	0.65	0.70	92.86		
11AC20MIMO	Ant1	5180	1.31	1.37	95.62	
	Ant2	5180	1.31	1.36	96.32	
	Ant1	5200	1.31	1.37	95.62	
	Ant2	5200	1.31	1.37	95.62	
	Ant1	5240	1.31	1.37	95.62	
	Ant2	5240	1.31	1.37	95.62	
	Ant1	5260	1.31	1.37	95.62	
	Ant2	5260	1.31	1.36	96.32	
	Ant1	5280	1.31	1.37	95.62	
	Ant2	5280	1.31	1.37	95.62	
Ant1	5320	1.31	1.37	95.62		

	Ant2	5320	1.31	1.37	95.62
	Ant1	5500	1.31	1.37	95.62
	Ant2	5500	1.31	1.37	95.62
	Ant1	5580	1.31	1.37	95.62
	Ant2	5580	1.32	1.37	96.35
	Ant1	5700	1.31	1.37	95.62
	Ant2	5700	1.31	1.37	95.62
	Ant1	5720	1.31	1.37	95.62
	Ant2	5720	1.31	1.37	95.62
	Ant1	5745	1.31	1.37	95.62
	Ant2	5745	1.31	1.36	96.32
	Ant1	5785	1.31	1.37	95.62
	Ant2	5785	1.31	1.36	96.32
	Ant1	5825	1.31	1.37	95.62
	Ant2	5825	1.31	1.37	95.62
11AC40MIMO	Ant1	5190	0.65	0.70	92.86
	Ant2	5190	0.65	0.70	92.86
	Ant1	5230	0.65	0.70	92.86
	Ant2	5230	0.65	0.70	92.86
	Ant1	5270	0.65	0.70	92.86
	Ant2	5270	0.65	0.70	92.86
	Ant1	5310	0.66	0.71	92.96
	Ant2	5310	0.66	0.71	92.96
	Ant1	5510	0.66	0.71	92.96
	Ant2	5510	0.65	0.70	92.86
	Ant1	5550	0.65	0.71	91.55
	Ant2	5550	0.65	0.71	91.55
	Ant1	5670	0.65	0.71	91.55
	Ant2	5670	0.65	0.71	91.55
	Ant1	5710	0.65	0.70	92.86
	Ant2	5710	0.65	0.70	92.86
	Ant1	5755	0.65	0.70	92.86
	Ant2	5755	0.65	0.71	91.55
	Ant1	5795	0.65	0.70	92.86
	Ant2	5795	0.65	0.70	92.86
11AC80MIMO	Ant1	5210	0.32	0.37	86.49
	Ant2	5210	0.32	0.37	86.49
	Ant1	5290	0.32	0.37	86.49
	Ant2	5290	0.32	0.36	88.89
	Ant1	5530	0.32	0.37	86.49
	Ant2	5530	0.32	0.37	86.49
	Ant1	5610	0.33	0.37	89.19
	Ant2	5610	0.32	0.37	86.49
	Ant1	5690	0.32	0.37	86.49
	Ant2	5690	0.32	0.37	86.49
	Ant1	5775	0.32	0.37	86.49
	Ant2	5775	0.33	0.37	89.19

8.5. Original Test Data

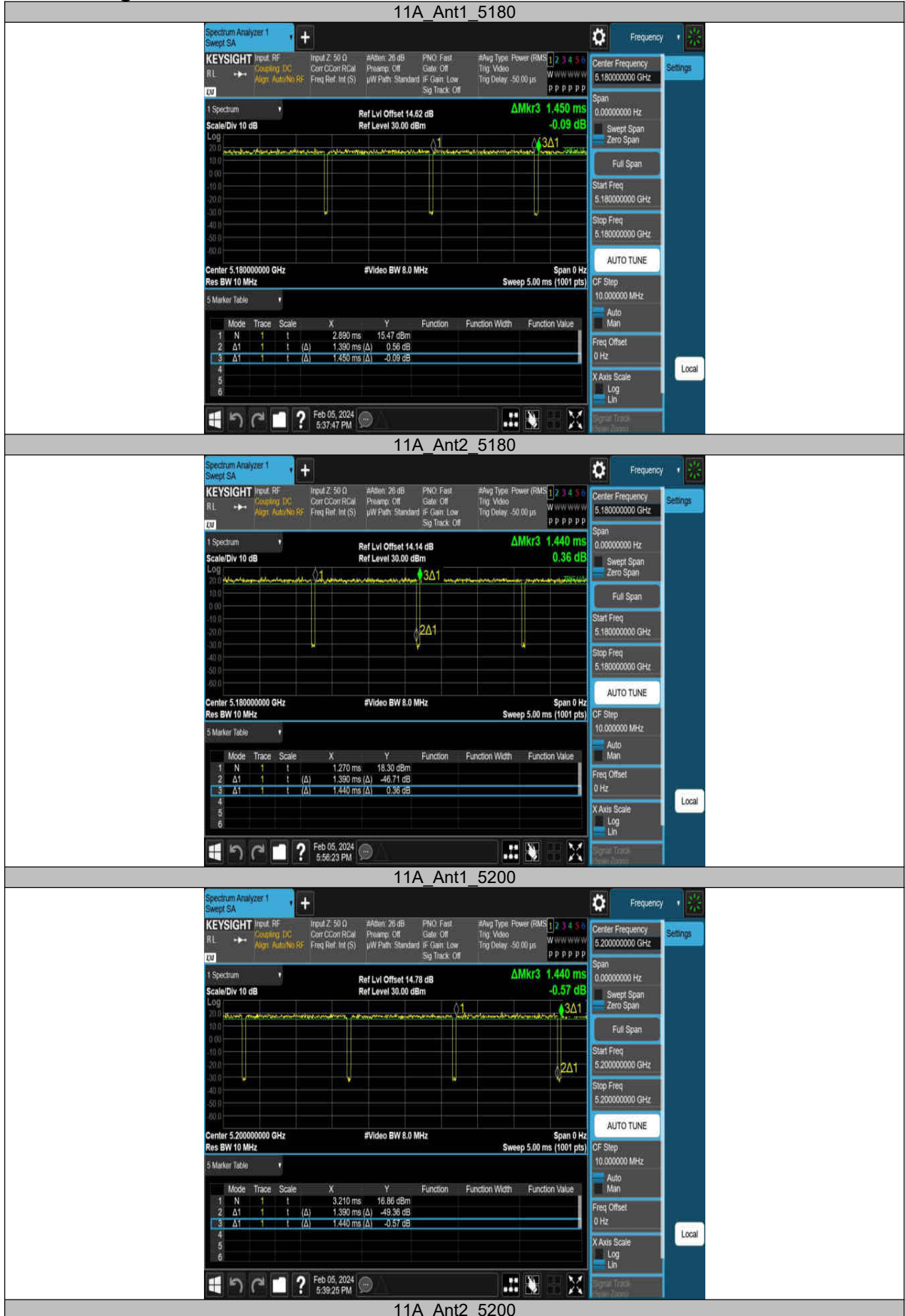

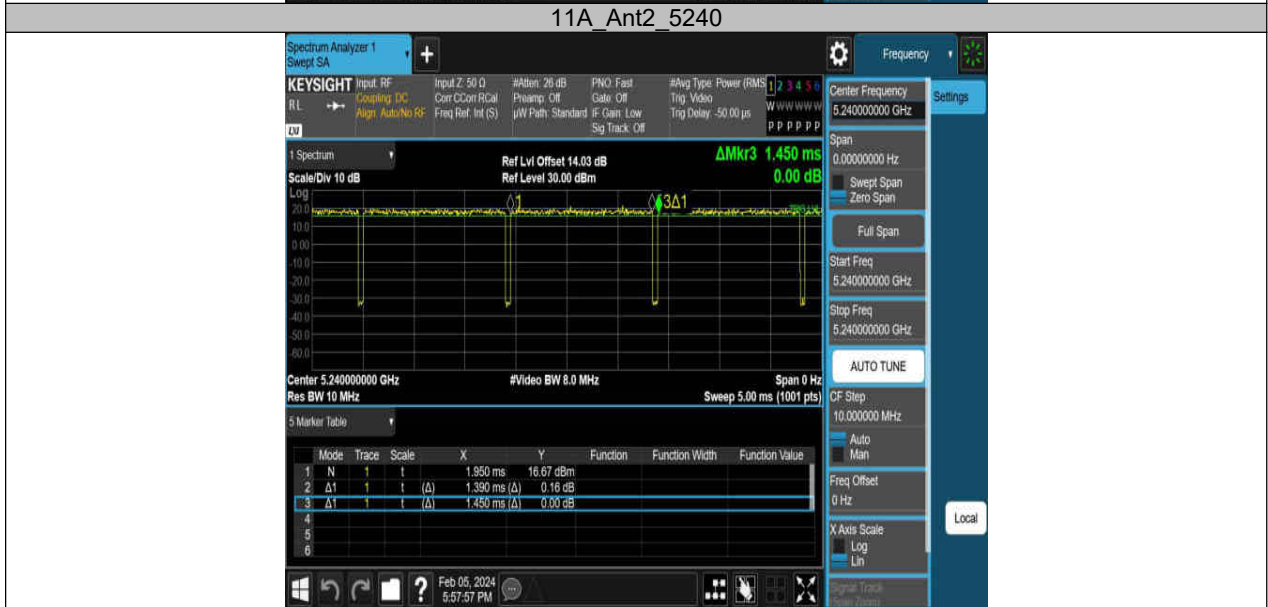
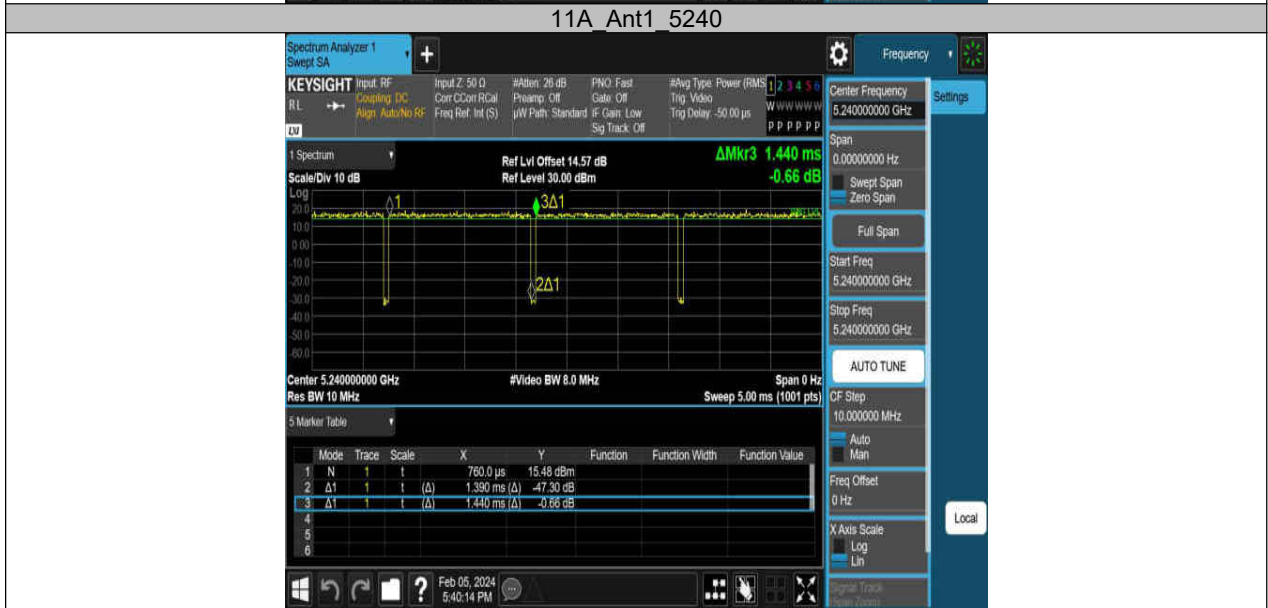

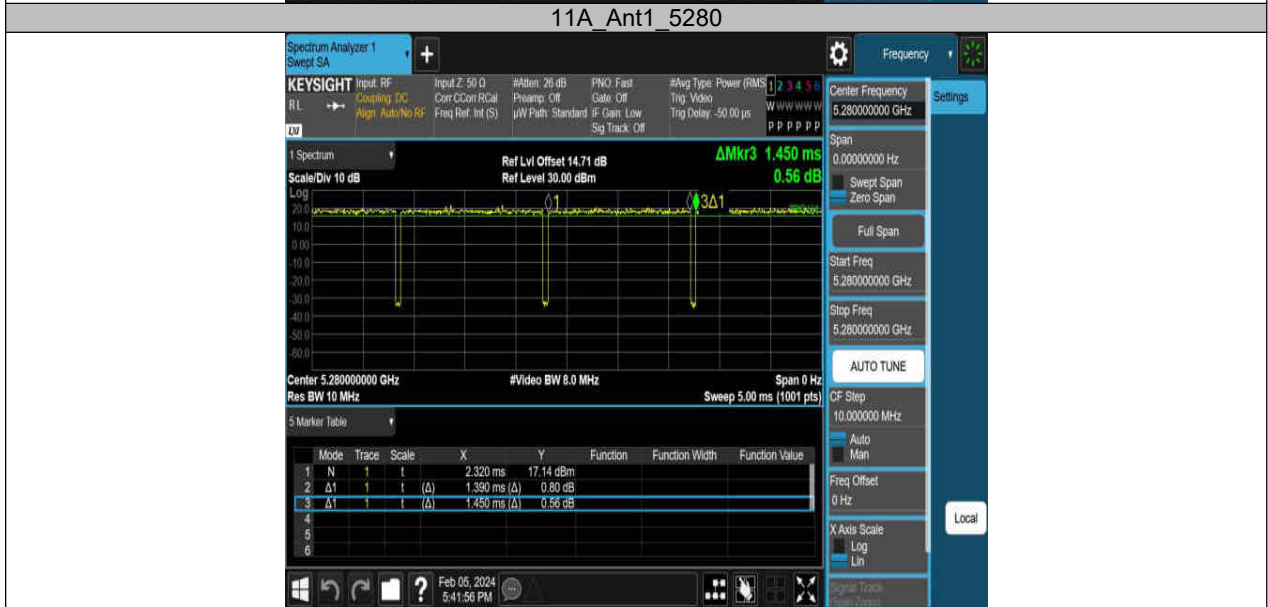
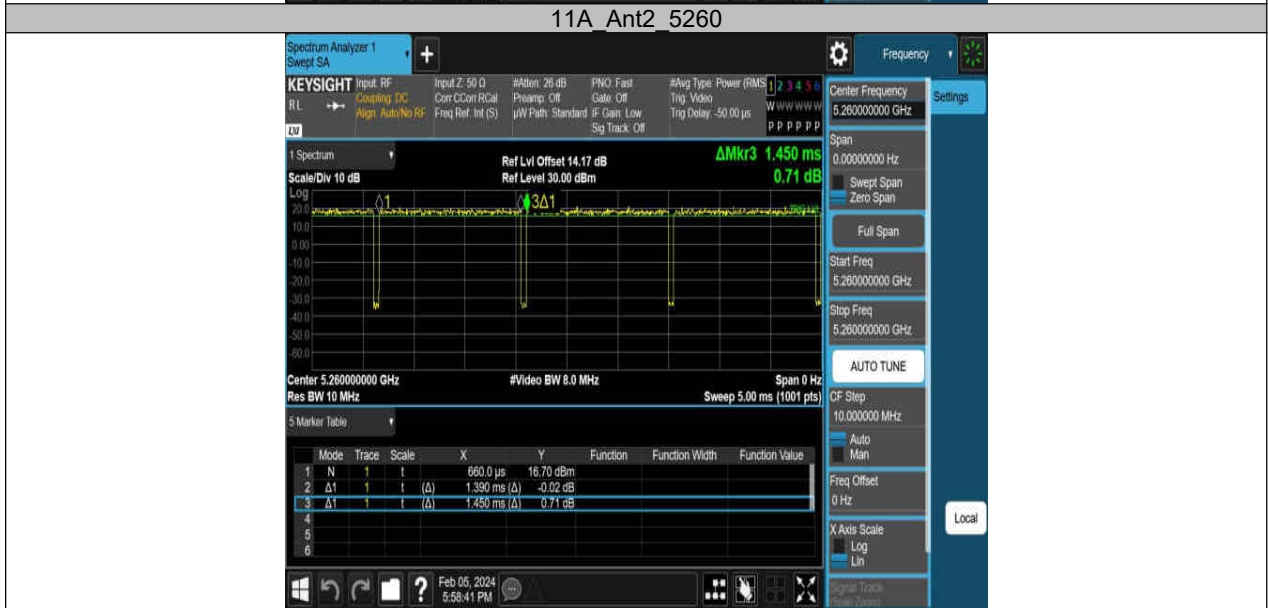



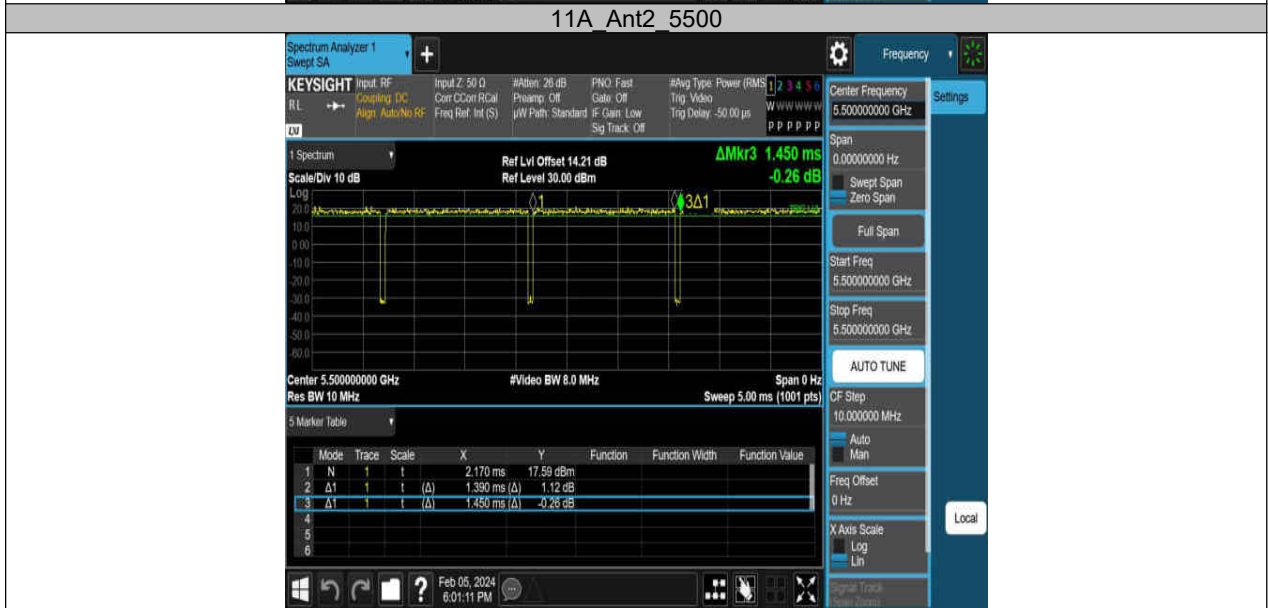

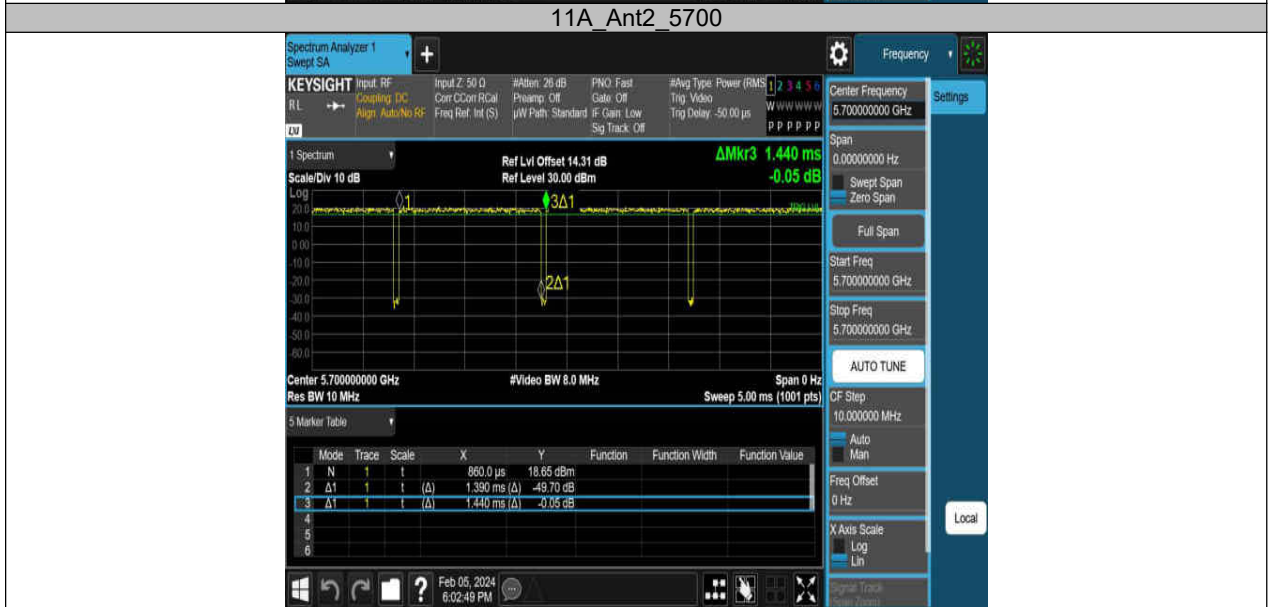



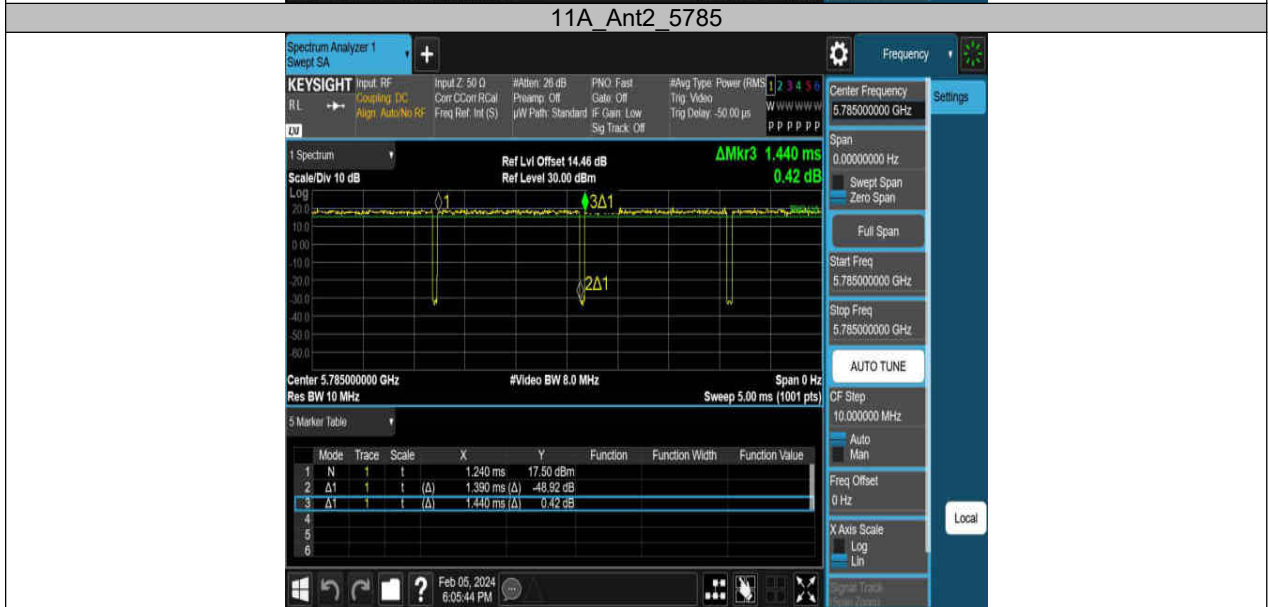
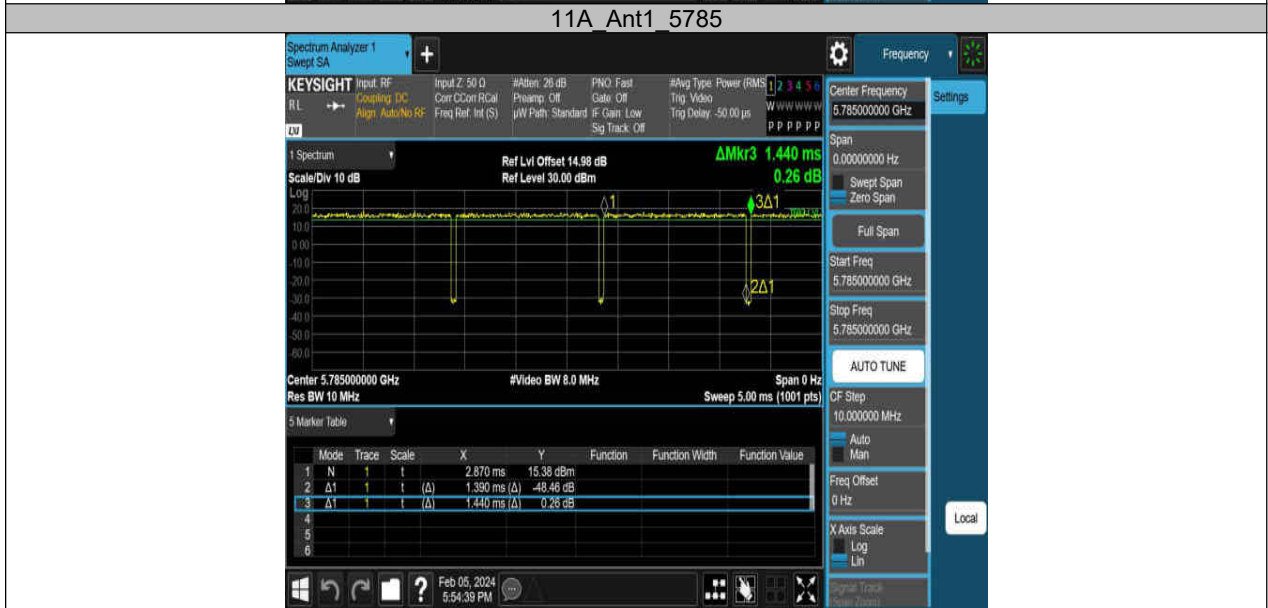

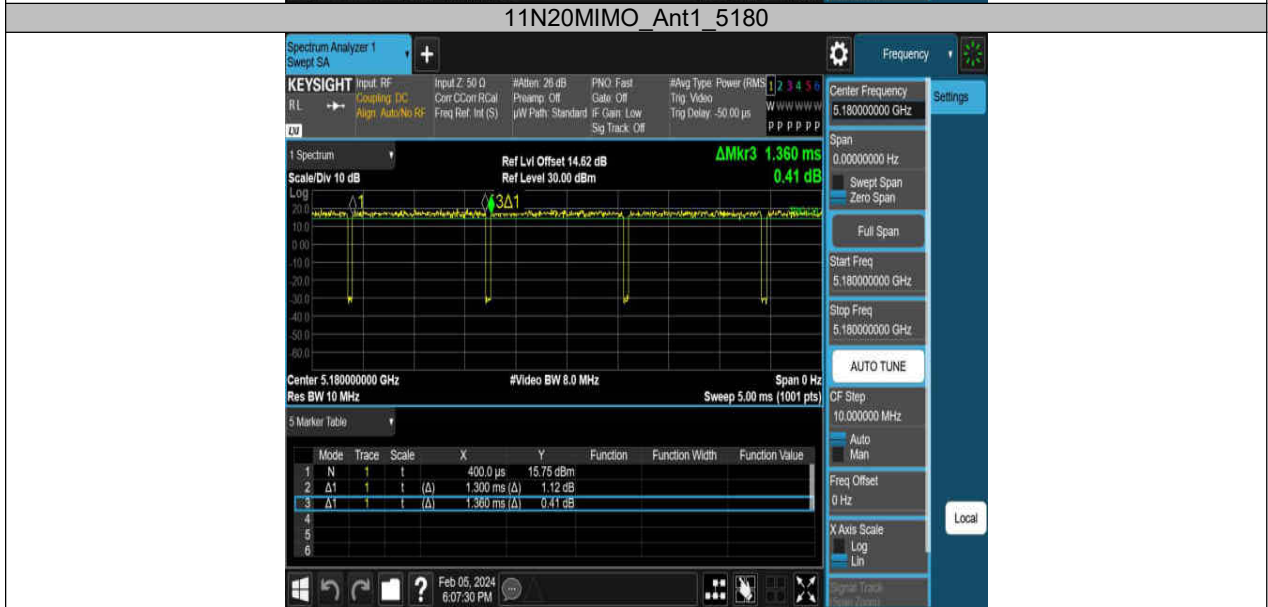
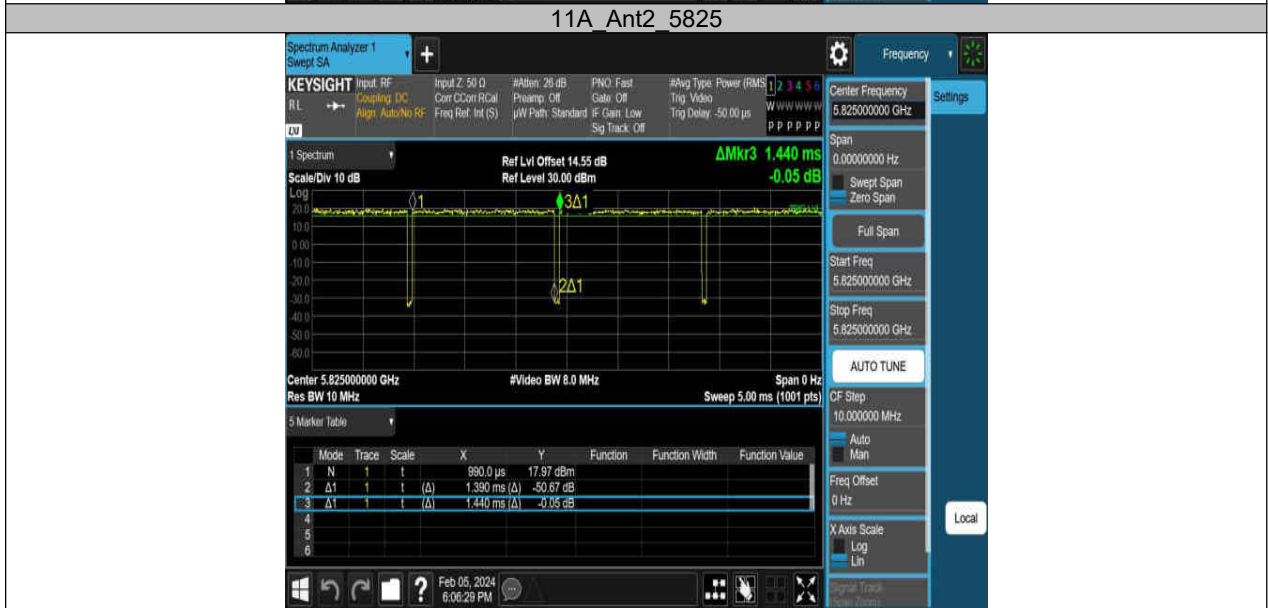



11N20MIMO Ant1 5200



11N20MIMO Ant2 5200



11N20MIMO Ant1 5240



11N20MIMO Ant2 5240



11N20MIMO Ant2 5260



11N20MIMO Ant1 5260



11N20MIMO Ant1 5280



11N20MIMO Ant2 5280



11N20MIMO Ant1 5320



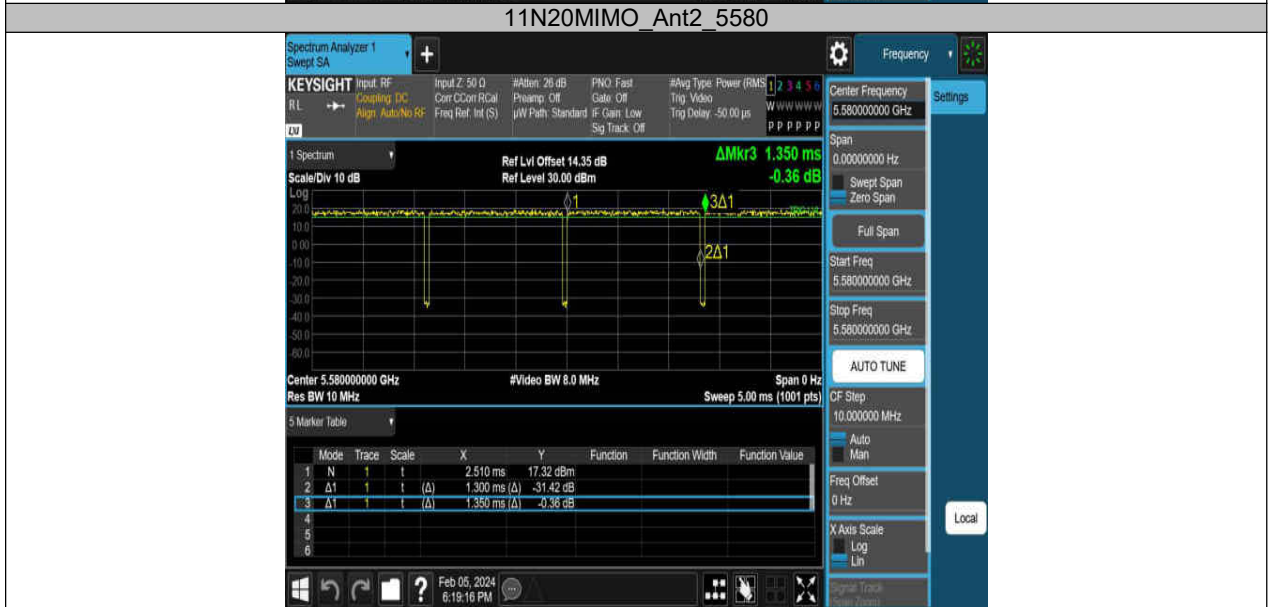
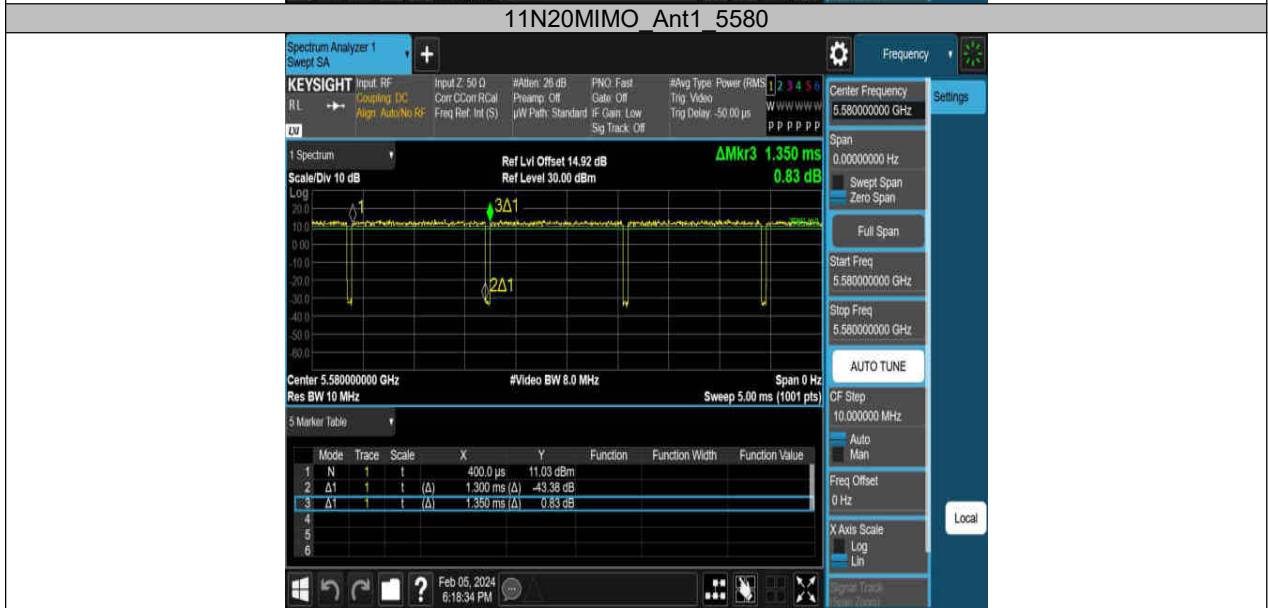

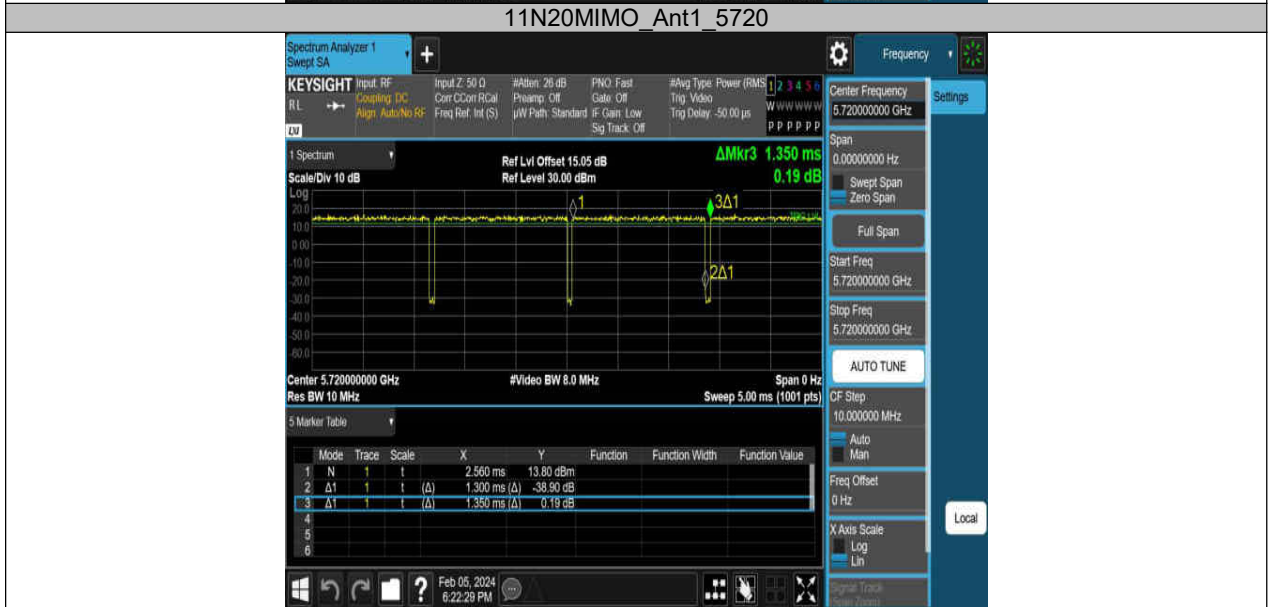
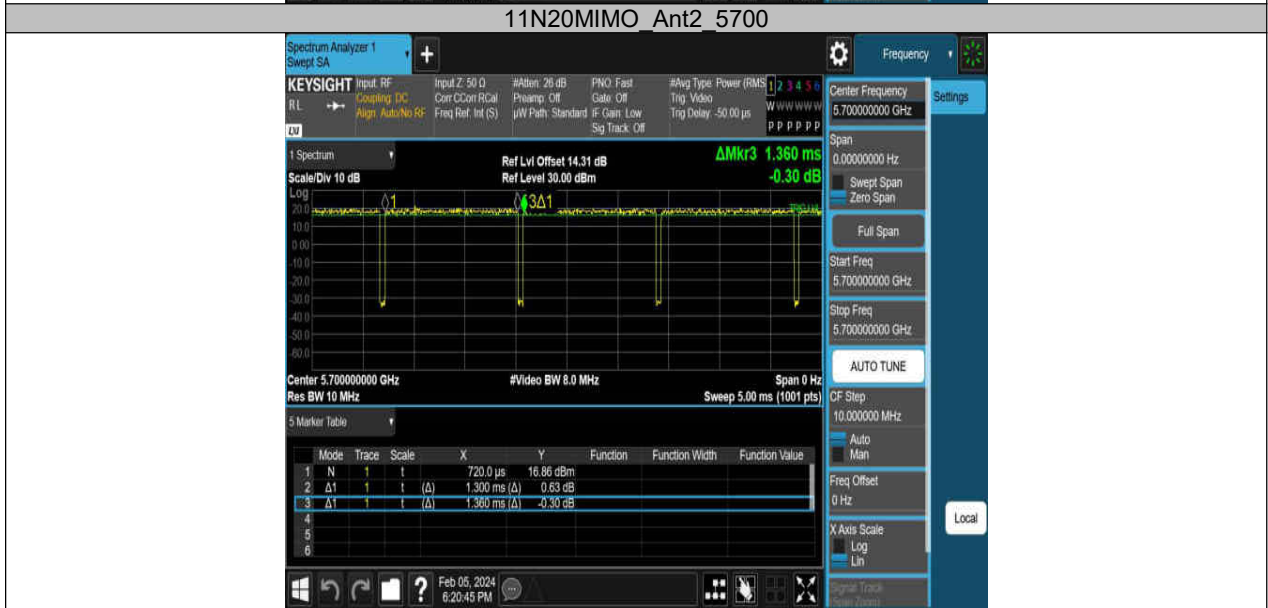

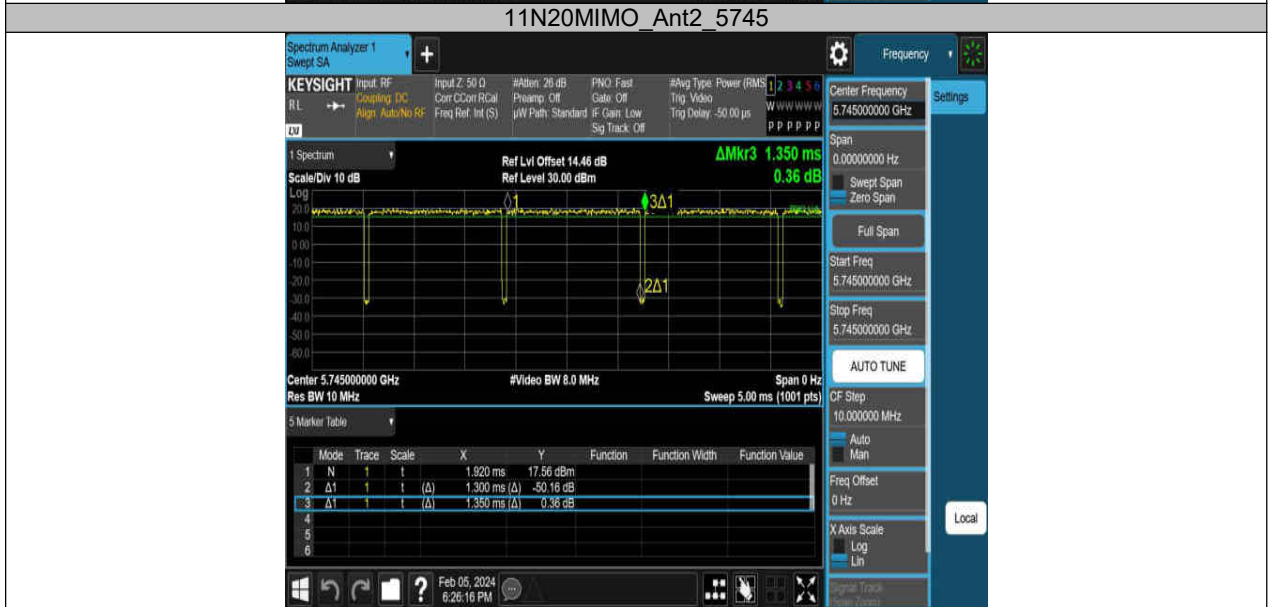
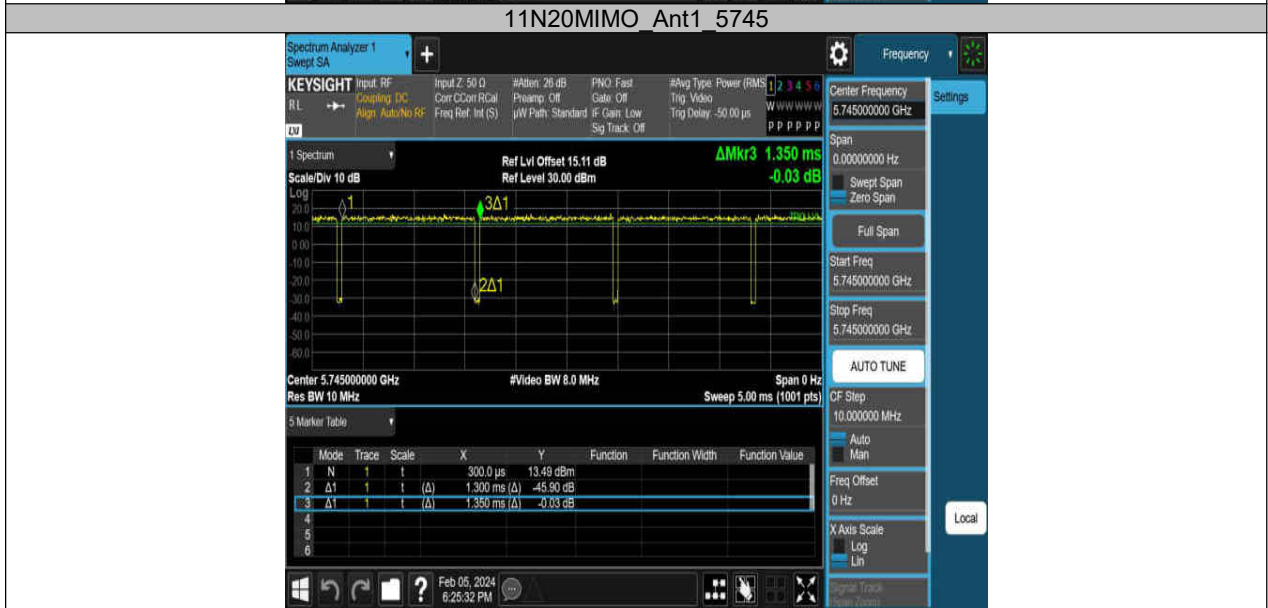

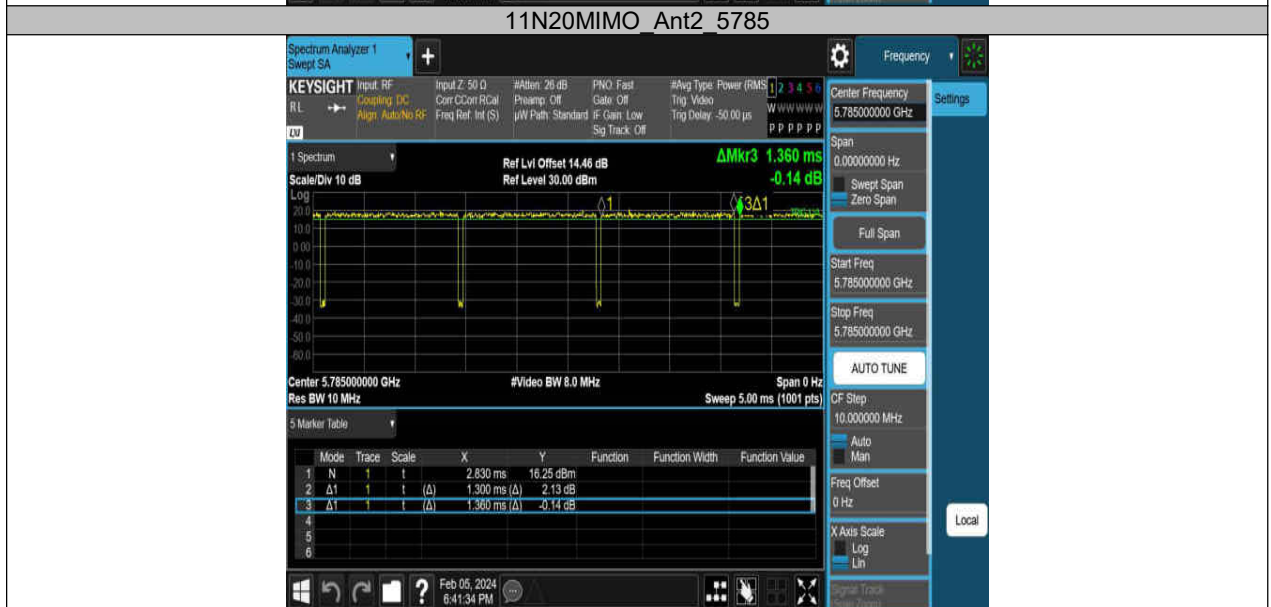

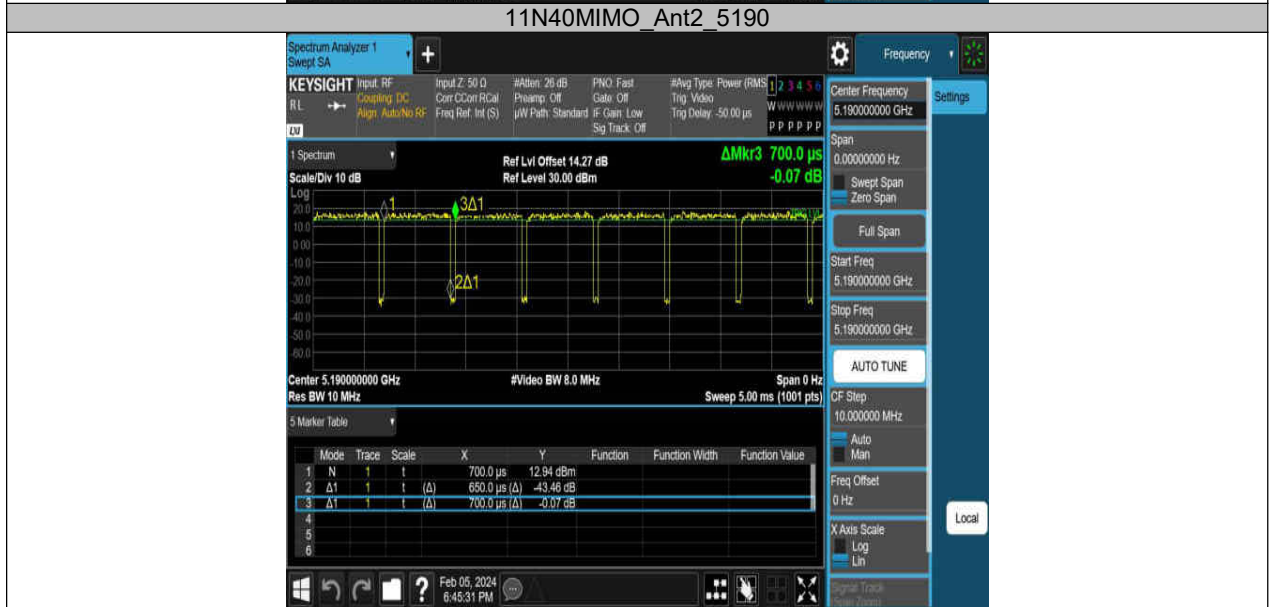
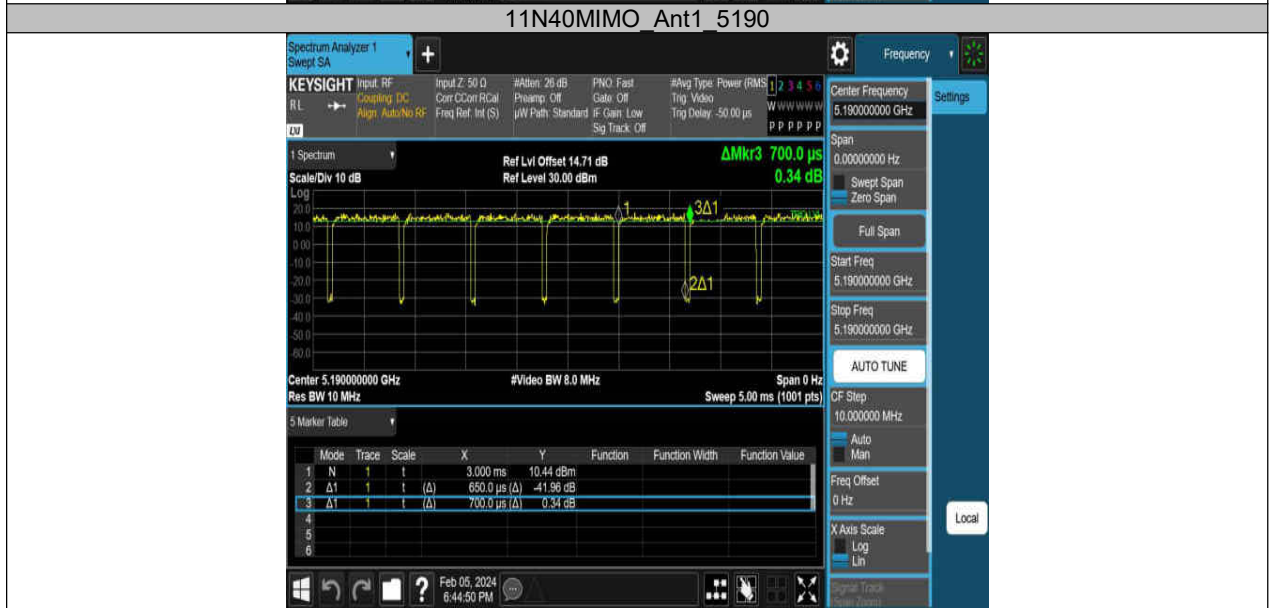



11N40MIMO Ant2 5230



11N40MIMO Ant1 5270



11N40MIMO Ant2 5270

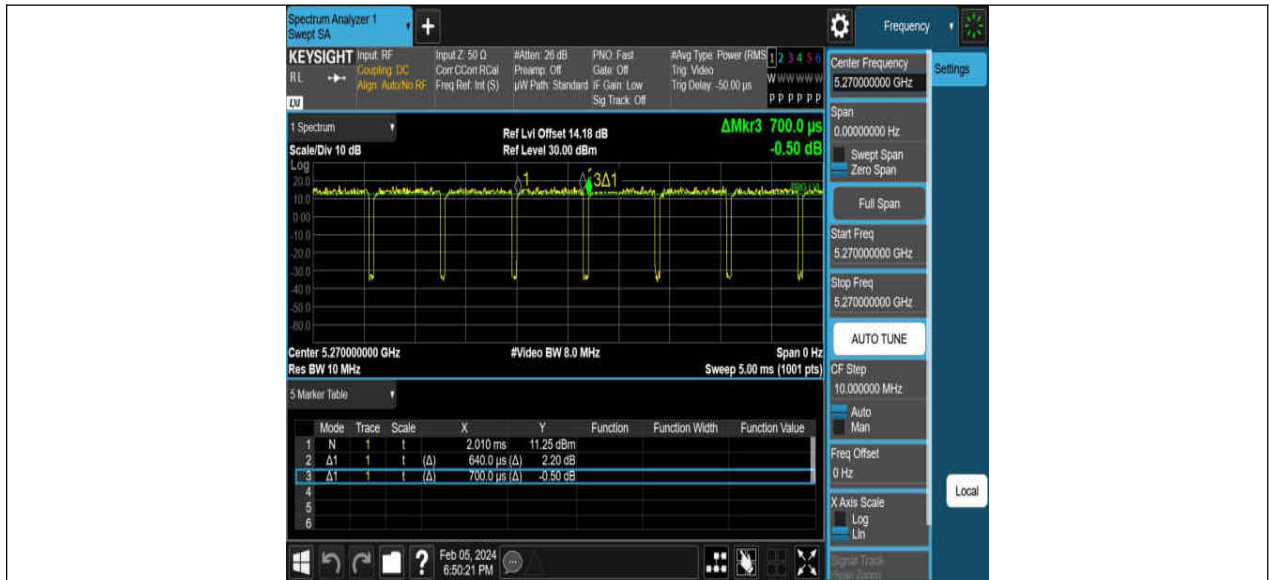

11N40MIMO Ant1 5310

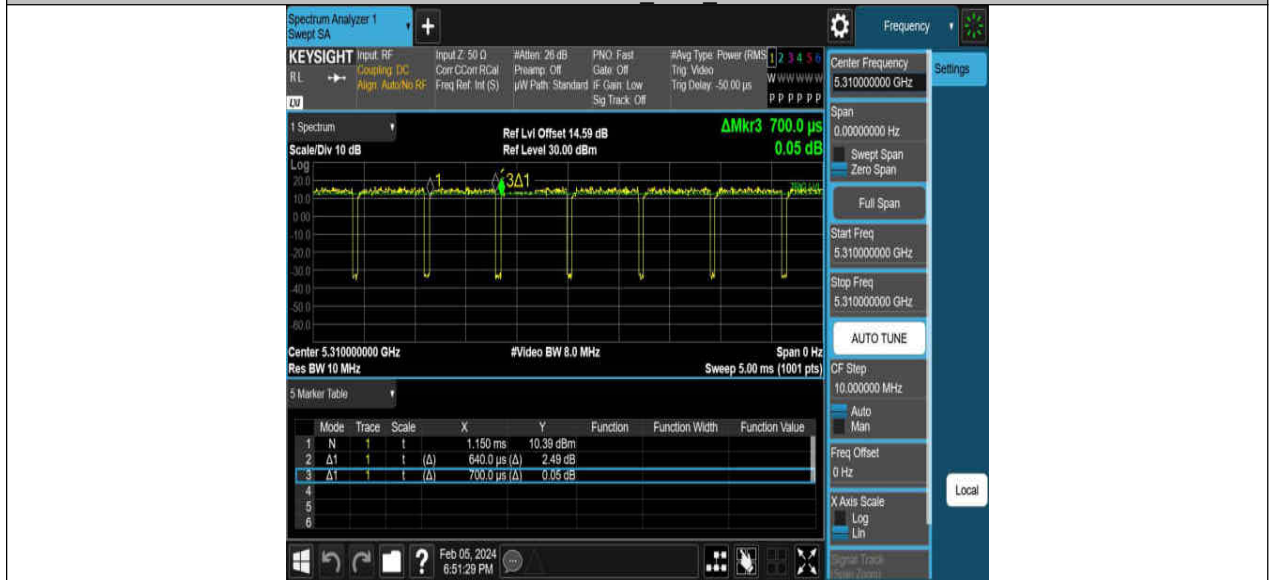

11N40MIMO Ant2 5310



11N40MIMO Ant1 5510



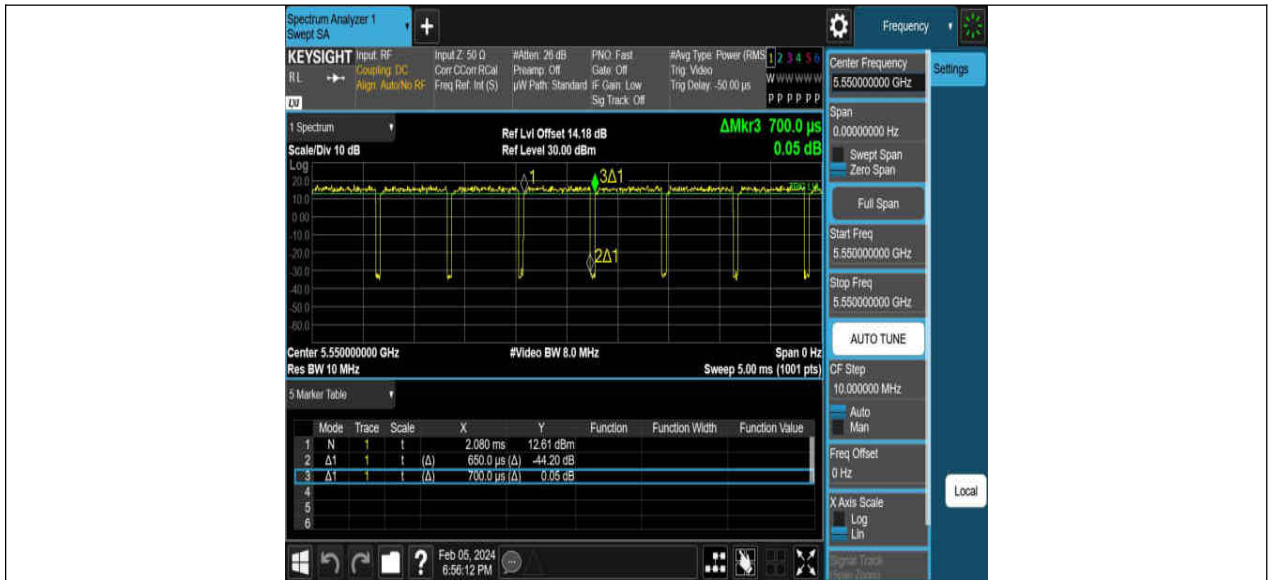

11N40MIMO Ant1 5670



11N40MIMO Ant2 5670



11N40MIMO Ant1 5710



11N40MIMO Ant2 5710



11N40MIMO Ant1 5755



11N40MIMO Ant2 5755