

ANTENNA INFORMATION

OEM	NA
ODM	Compal
Platform model name	MP24-XENON-C
Intel platform (ex: Yes, No or NA)	NA
Platform type (ex: regular NB, convertible PC, AIO...etc)	Tablet
SAR minimum separation (mm)	NA

Antenna manufacturer	INPAQ Technology Co.,Ltd.		
Address	2F., No.135, Ligone St., Beitou Dist., Taipei City 112019, Taiwan(R.O.C)		
Antenna Part number	DC33002Y08H (WA-P-LA-03-325)		
Antenna type (ex: PIFA, Dipole...etc)	PIFA		

Antenna Peak gain w/ cable loss (dBi)*										
	2400MHz	2450MHz	2500MHz							
Main	2.8	2.71	2.67							

Cable Assembly Part Number and Information					
	Cable PN	Cable length(mm)	Cable diameter(mm)	Impedance(ohm)	Connector type
Main	01-13LC2-0P4	410	1.13	50 ohm	I-PEX

* 3D Antenna Peak Gain required being test in system basis.

1. Test & System Description

1.1 Measurement Method and System

Test setting:

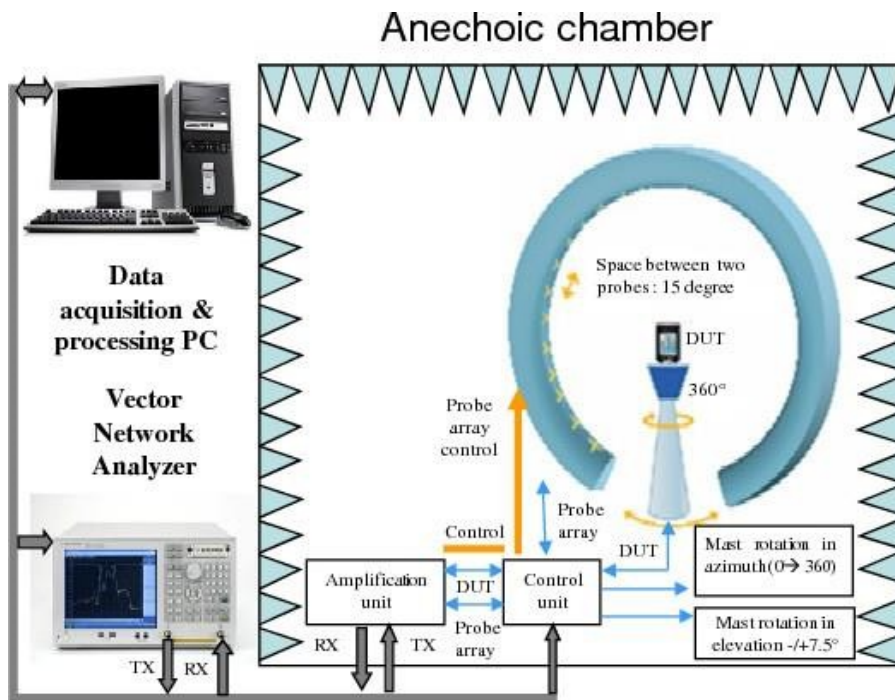

1.2 Test setup

Refer to Annex A.1 Setup Photo

1.3 Equipment list

Device	Manufacturer
■ SATIMO SG24 system : 0.4 to 6 GHz	MVG
■ Control unit	MVG
■ Power and control unit	MVG
■ Tx and Rx amplification units	MVG
■ Instrumentation rack	MVG
■ Uninterruptible power supply	FT
■ Reference horns	MVG
■ Vector Network Analyzer	Agilent E5071C

2. Radiation characteristics of antenna loaded in Host Platform

Main Antenna

- WLAN Antenna: 2400MHz

Peak Gain	Total
	2.8

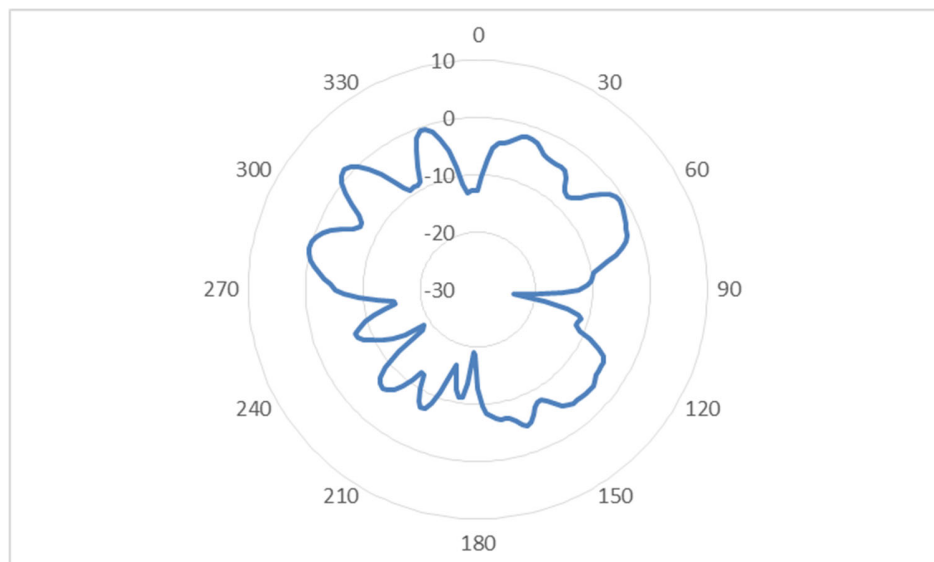

■ WLAN Antenna: 2450MHz

Peak Gain	Total
	2.71

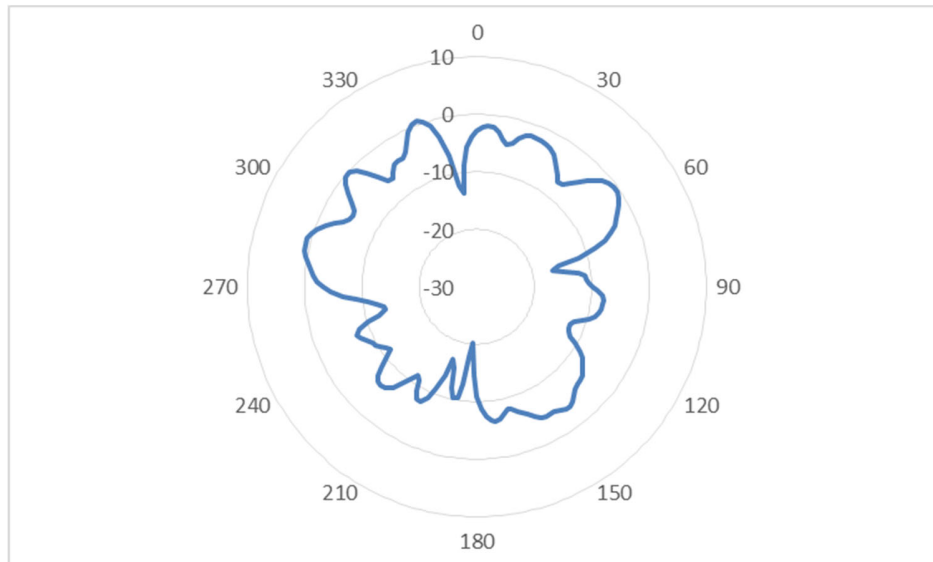

■ WLAN Antenna: 2500MHz

Peak Gain	Total
	2.67

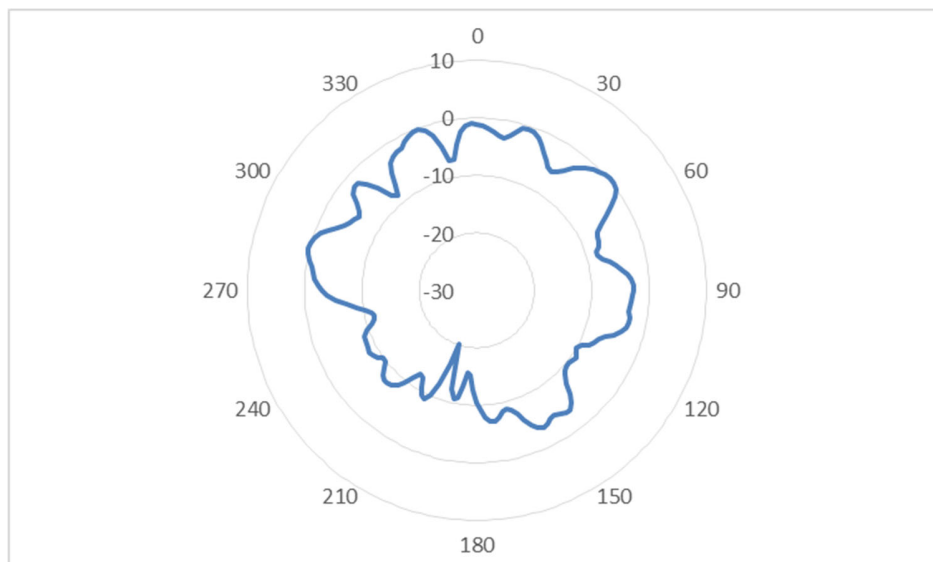

ANTENNA INFORMATION

OEM	NA
ODM	Compal
Platform model name	MP24-XENON-C
Intel platform (ex: Yes, No or NA)	NA
Platform type (ex: regular NB, convertible PC, AIO...etc)	Tablet
SAR minimum separation (mm)	NA

Antenna manufacturer	INPAQ Technology Co.,Ltd.	
Address	2F., No.135, Ligone St., Beitou Dist., Taipei City 112019, Taiwan(R.O.C)	
Antenna Part number	Main:DC33002Y06H (WA-P-LE-02-279)	Aux:DC33002Y07H (WA-P-LE-01-078)
Antenna type (ex: PIFA, Dipole...etc)	PIFA	

Antenna Peak gain w/ cable loss (dBi)*										
	2400MHz	2450MHz	2500MHz	5150MHz	5500MHz	5850MHz				
Main	2.8	2.76	2.92	2.74	2.95	2.54				
Aux	2.78	2.31	2.95	2.54	2.98	2.96				

Cable Assembly Part Number and Information					
	Cable PN	Cable length(mm)	Cable diameter(mm)	Impedance(ohm)	Connector type
Main	01-13LC0-0P4	285	1.13	50 ohm	I-PEX
Aux	01-13LC1-0P4	400	1.13	50 ohm	I-PEX

* 3D Antenna Peak Gain required being test in system basis.

1. Test & System Description

1.1 Measurement Method and System

Test setting:

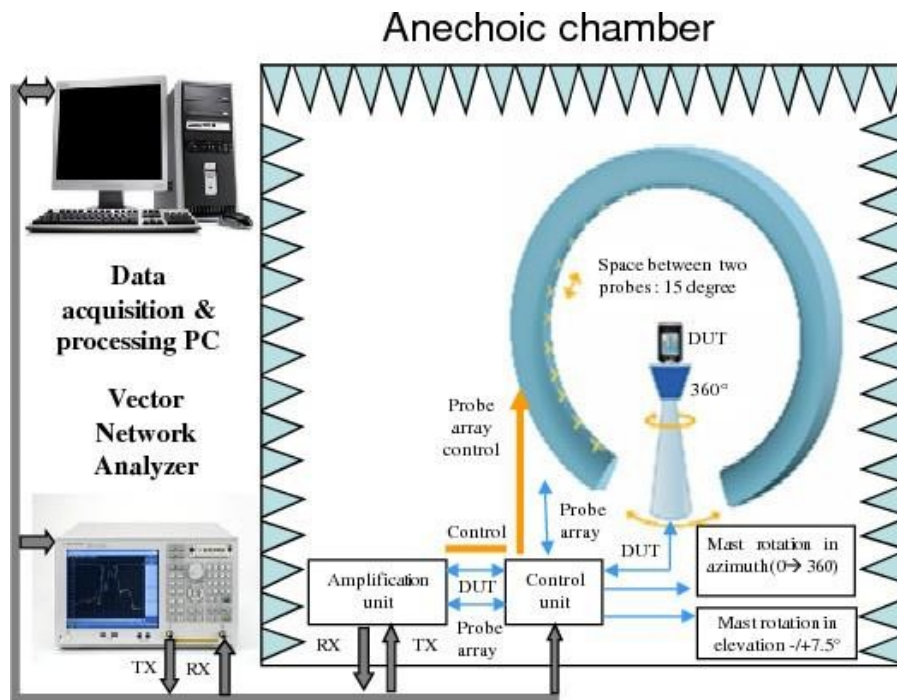

1.2 Test setup

Refer to Annex A.1 Setup Photo

1.3 Equipment list

Device	Manufacturer
■ SATIMO SG24 system : 0.4 to 6 GHz	MVG
■ Control unit	MVG
■ Power and control unit	MVG
■ Tx and Rx amplification units	MVG
■ Instrumentation rack	MVG
■ Uninterruptible power supply	FT
■ Reference horns	MVG
■ Vector Network Analyzer	Agilent E5071C

2. Radiation characteristics of antenna loaded in Host Platform

Main Antenna

- WLAN Antenna: 2400MHz

Peak Gain	Total
	2.8

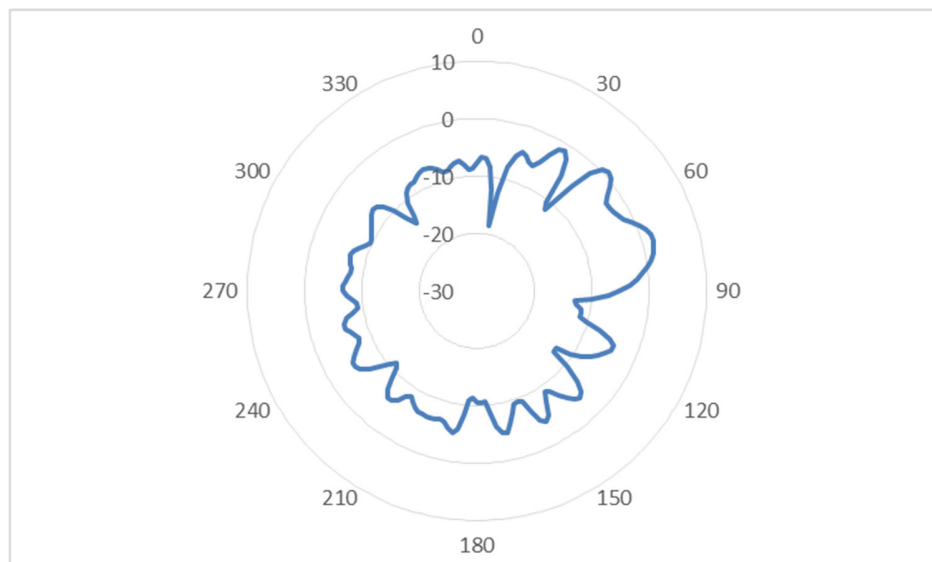

■ WLAN Antenna: 2450MHz

Peak Gain	Total
	2.76

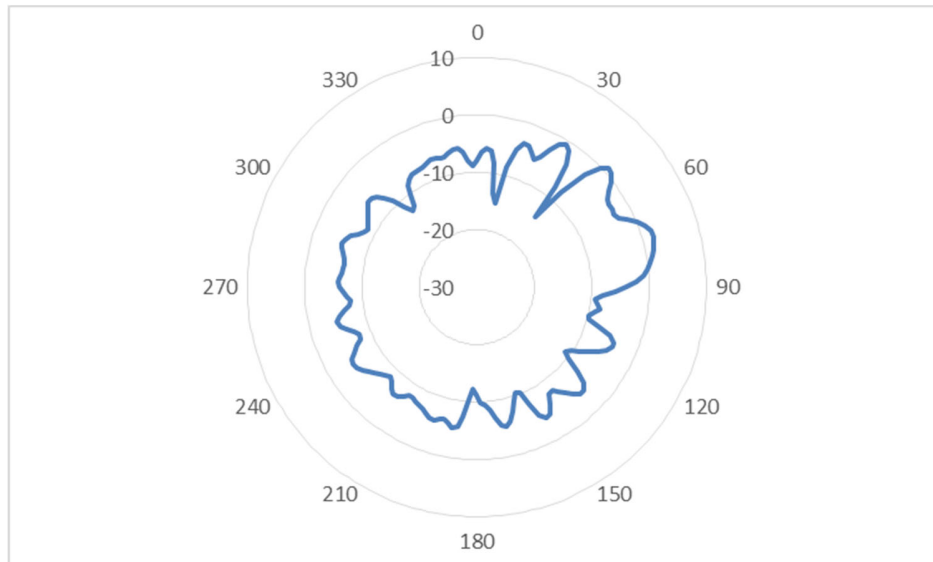

■ WLAN Antenna: 2500MHz

Peak Gain	Total
	2.92

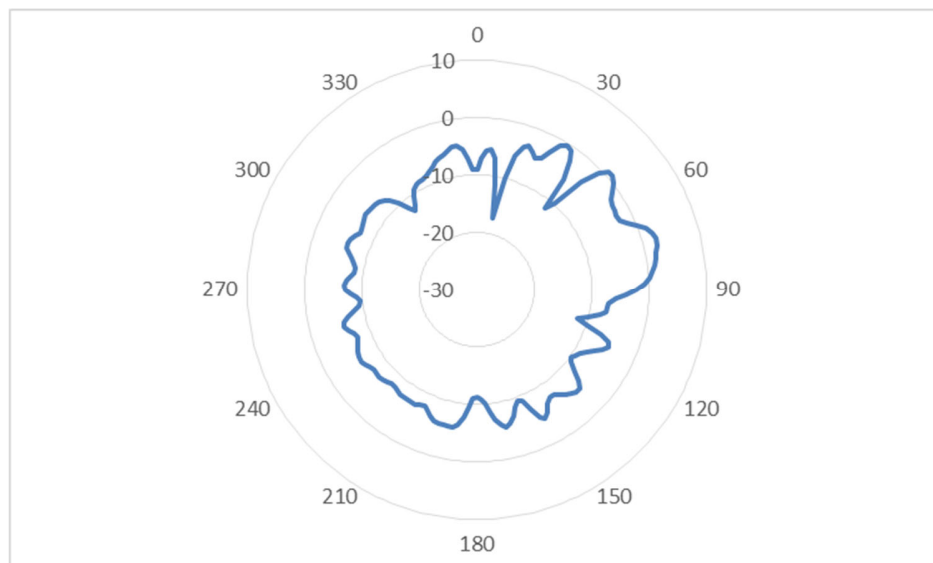

5150-5850 MHz radiation characteristic

■ WLAN Antenna: 5150MHz

Peak Gain	Total
	2.74

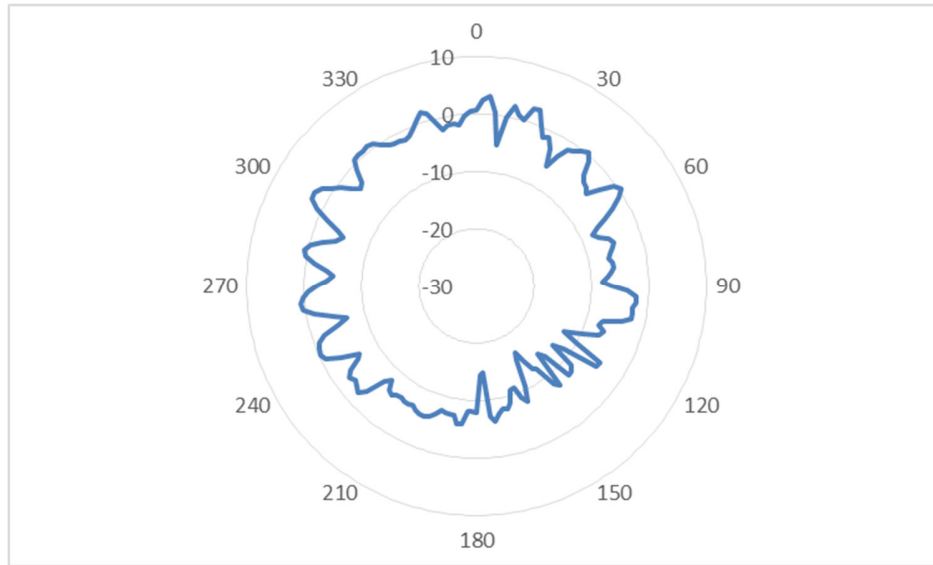

■ WLAN Antenna: 5500MHz

Peak Gain	Total
	2.95

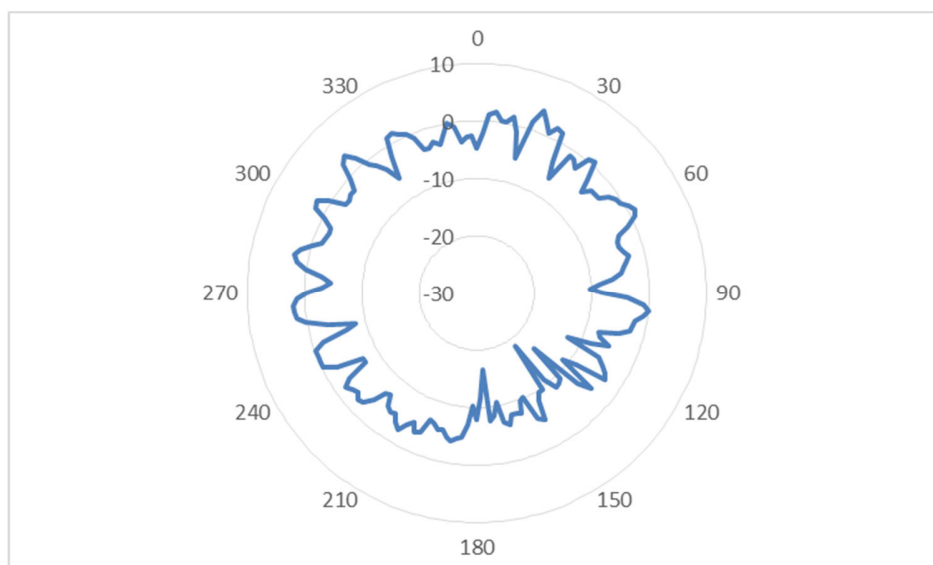

■ WLAN Antenna: 5850MHz

Peak Gain	Total
	2.54

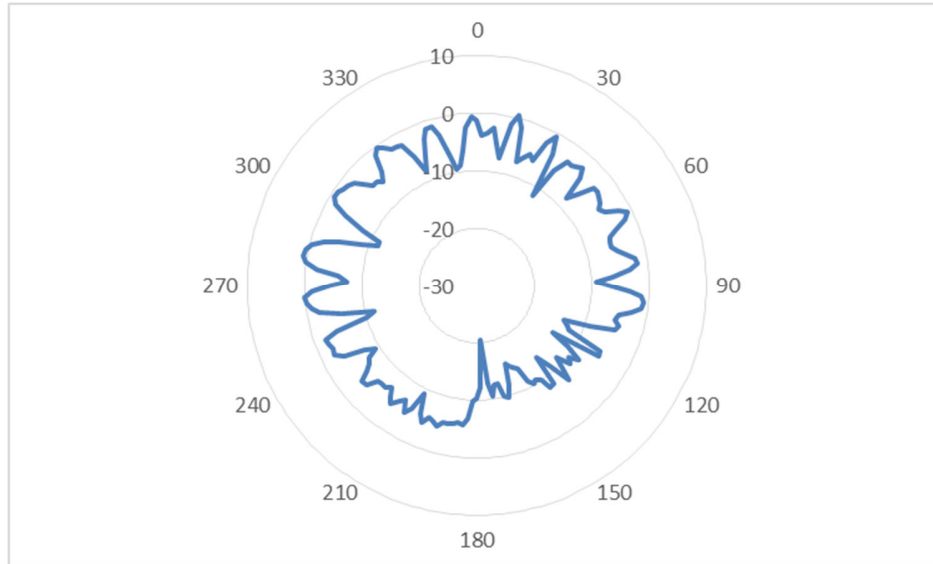

Auxiliary Antenna

- WLAN Antenna: 2400MHz

Peak Gain	Total
	2.78

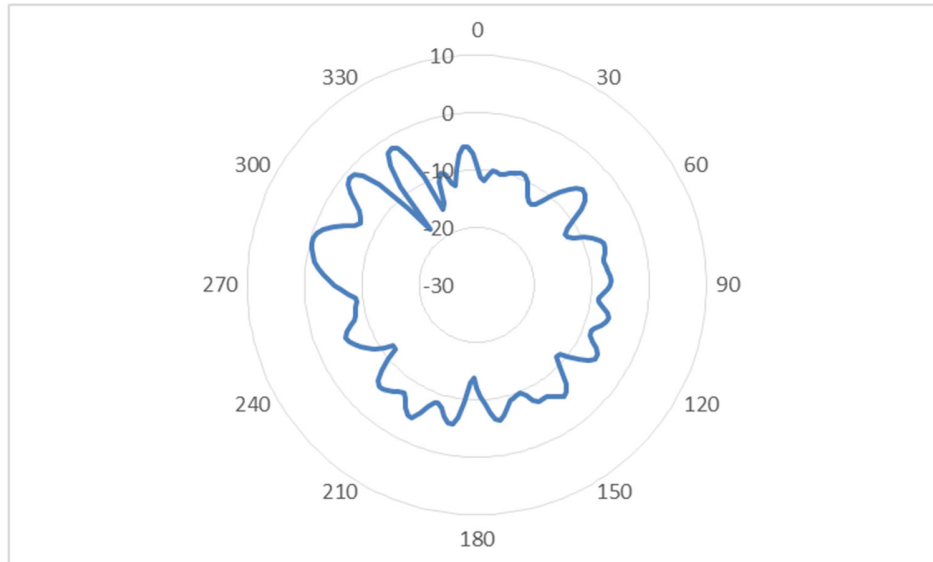

■ WLAN Antenna: 2450MHz

Peak Gain	Total
	2.31

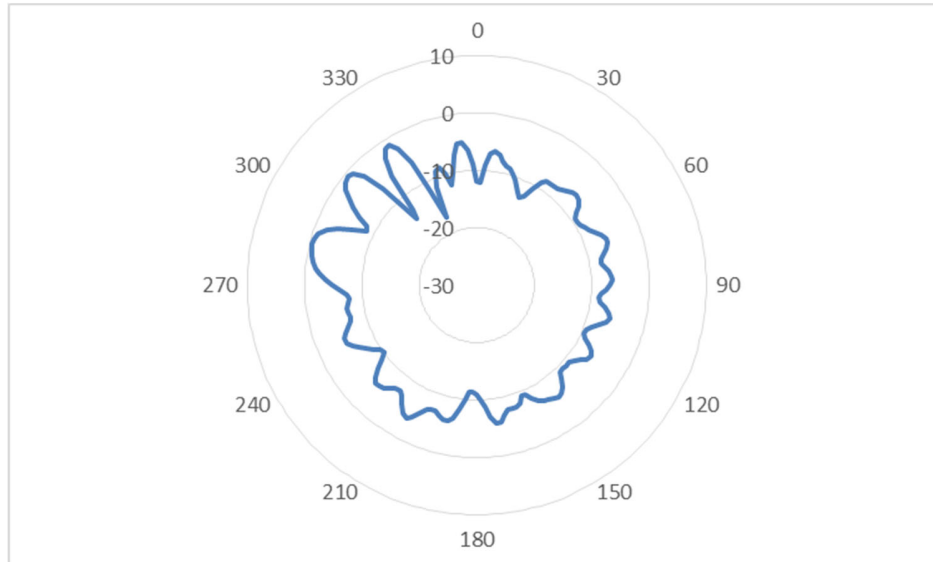

■ WLAN Antenna: 2500MHz

Peak Gain	Total
	2.95

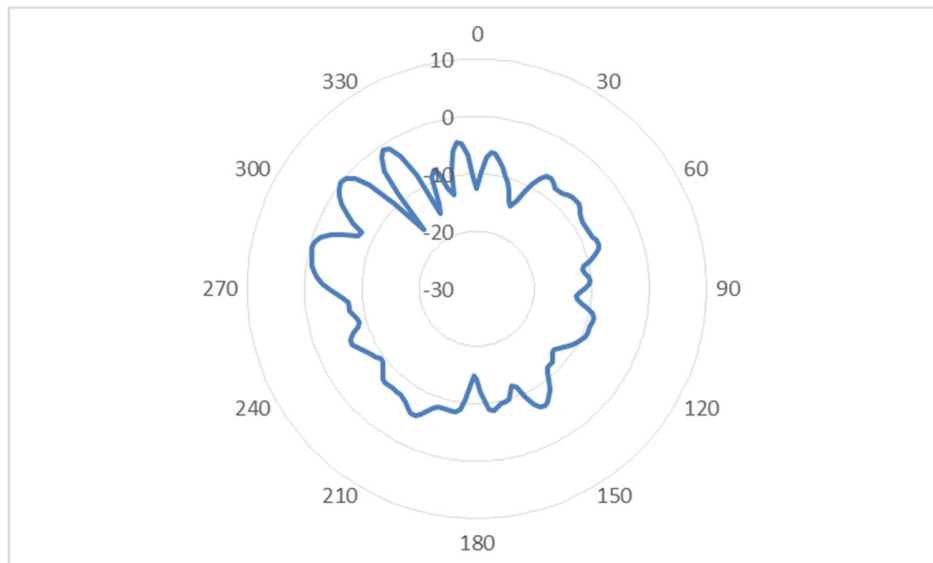

5150-5850 MHz radiation characteristic

■ WLAN Antenna: 5150MHz

Peak Gain	Total
	2.54

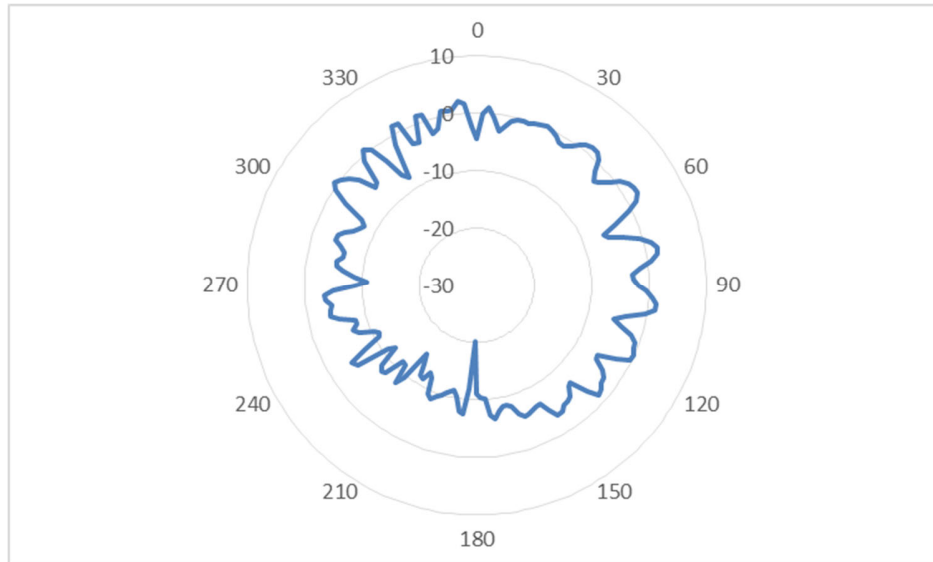

■ WLAN Antenna: 5500MHz

Peak Gain	Total
	2.98

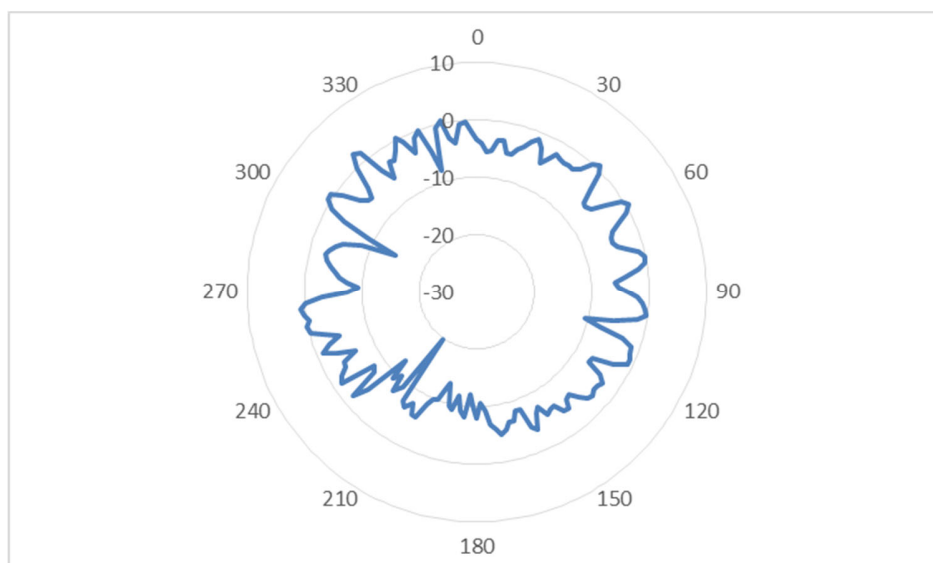

■ WLAN Antenna: 5850MHz

Peak Gain	Total
	2.96

