

DNB ENGINEERING, INC.

CERTIFICATION FOR INTENTIONAL RADIATOR
--

per
Part 15 Subpart C
(CFR 47, 15.203 & 15.209)

Model No. 1219
121 kHz EKG Pulse Transmitter

PREPARED FOR APPLICANT:
ICON HEALTH AND FITNESS
1500 S. 1000 West
Logan, UT 84321

REPORT # 96100-1
Test Date: 17 June 1999

Prepared By:
DNB ENGINEERING, INC.
1100 East Chalk Creek Rd.
Coalville, Utah 84017
Tel: 1(435) 336-4433

Revision Letter	Number of Pages	Page No. of Rev.	Description	Date
A			Document Release	

TRANSMITTAL SUMMARY

Unit tested: Sample #1
Model #: 1219
FCC ID: OMC1299

Specifications: ANSI C63.4 (1992) and CFR 47 FCC part 15 Subpart C

Purpose of Report: This report was prepared to document the status of the 121 kHz Heart Rate Transmitter with requirements of the standards listed above.

Requirements not applicable to EUT
Part 15.37 - Not applicable
Emergency Broadcast System - Not applicable
Spread Spectrum Exhibit - Not applicable
Scanning Receiver - Not applicable

Test Summary The EUT's compliance status according to the tests performed is as follows.

REQUIREMENTS	STATUS
FCC part 15 Subpart C	
per 15.203 & 15.209	COMPLIANT

The report shall not be reproduced, except in full, without the written approval of DNB ENGINEERING, INC. Results contained in this report relate only to the item tested.

TABLE OF CONTENTS

1. INTRODUCTION.....	6
1.1 ADMINISTRATIVE DATA PER 2.1033(A) AND 2.911(C).....	6
1.1.1 REQUEST FOR CERTIFICATION Per 2.1033(b)1:.....	6
1.2 RELATED SUBMITTALS/GRANTS.....	6
1.3 PURPOSE OF TESTS.....	6
2. TEST DESCRIPTION	7
2.1 TEST CONFIGURATION.....	7
2.2 EQUIPMENT DESCRIPTION.....	7
2.3 MODE OF OPERATION	7
2.4 ANTENNA REQUIREMENT - PER 15.203	7
2.5 CIRCUIT DESCRIPTION - PER 2.1033(B)4.....	8
2.6 SCHEMATICS	9
2.7 PHOTOGRAPH OF EUT - PER 2.1033(B)(7).....	11
3. EMISSIONS FCC PART 15	13
3.1 RADIATED EMISSIONS TEST SETUP AND PROCEDURE - PER 2.1033(B)(6) PER 2.947(A).....	13
3.1.1 Spurious Radiation Test Site Per 2.1033(b)6.....	13
3.1.2 Example Of Typical Calculation Per 2.1033(b)6.....	15
3.1.3 Diagram of Test Setup - per 2.1033(b)5	16
3.1.4 Field Strength of Intentional Radiator Inside of Band	17
3.1.5 Spurious Radiated Emissions.....	18
3.1.6 Photograph of Radiated Test Setup - per 2.1033(b)(7).....	19
3.2 CONDUCTED EMISSIONS TEST SETUP AND PROCEDURE - PER 2.1033(B)(6) PER 2.947(A).....	20
4. LABELING REQUIREMENTS - PER 2.1033(B)(7).....	21
4.1 ADDITIONAL LABEL REQUIRED	21
4.2 PHOTOGRAPH OF LABEL PLACEMENT AND CONTENTS	22
5. OWNERS MANUAL.....	23
6. APPENDIX SECTION	24
6.1 APPENDIX A: TEST DATA.....	25
6.2 APPENDIX B: UNCERTAINTY TOLERANCE	28
6.3 APPENDIX C: TEST SITE CERTIFICATION, CHALK CREEK EMI SITE - PER 2.948(A).....	30
6.4 APPENDIX D: EMC INSTRUMENTATION	32
6.5 APPENDIX E: INFORMATION SUPPLIED TO APPLICANT.....	34

1. INTRODUCTION

1.1 Administrative Data Per 2.1033(a) and 2.911(c)

1.1.1 REQUEST FOR CERTIFICATION Per 2.1033(b)1:

Applicant: **ICON HEALTH AND FITNESS**
1500 S. 1000 West
Logan, UT 84321

Contact: Matt McKendrick

Dates of Test: 17 June 1999

Equipment Under Test (EUT): 121 kHz Heart Rate Transmitter (Sample #1)
FCC ID: OMC1299

1.2 Related Submittals/Grants

Not applicable.

1.3 Purpose of Tests

The purpose of this series of tests was to demonstrate the Electromagnetic Compatibility (EMC) characteristics of the EUT. The following tests were performed:

REQUIREMENTS	STATUS
FCC part 15 Subpart C	
per 15.209	COMPLIANT

2. TEST DESCRIPTION

2.1 Test Configuration

Config-uration	Unit Name - Processor, Monitor, Printer, Cable, etc. (indent for features of a unit)	Style/Model/Part No.	Serial Number	Obj. of test	VA C	Comments/ FCC ID#
A	Icon Health and Fitness 121 kHz EKG Pulse transmitter.	1219	Sample #1	■		3 VDC Battery

- - Specific device(s) for which this test is being conducted.

2.2 Equipment Description

Icon Health and Fitness 121 kHz Heart Rate Transmitter a wireless pulse monitor is used with exercise stations such as treadmills. The pulse monitor is strapped to the chest of the exerciser and the pulse rate is monitored and displayed at the console. An EKG is used to detect hart beats and 121 kHz CW is transmitted for each hart beat.

2.3 Mode of Operation

121 kHz Heart Rate Transmitter was hard wired to be transmitting continuously. Worst case orientation and azimuth of the turntable were determined, then a fresh battery was installed. Worst case was determined to be flat on the table as show in setup photo.

2.4 Antenna Requirement - per 15.203

The antenna is soldered to transmitter and enclosure is glued in place.

2.5 Circuit Description - per 2.1033(b)4

OPERATION OF SPORTS INSTRUMENTS 121 KHZ HEART RATE TRANSMITTER

The Sports Instrument 121khz Heart Rate Transmitter operates in the following manner.

- Two conductive rubber electrodes mounted to the left and right of the plastic transmitter body detect the user's heart rate signal (ECG).
- The electrodes are connected to the differential input terminals (+) and (-) of the amplifier circuit
- The amplified signal is run through a series of band-pass filters designed to eliminate any signals picked up by the electrodes that are not caused by the users heart rate signal while not eliminating the users ECG signal.
- A Threshold Detector detects any signals of amplitudes greater than the upper threshold of the Band Pass Filters and causes the activation of a One Shot Multi-Vibrator for each signal that activates the Threshold Detector.
- The One-Shot Multi-Vibrator activates a Relaxation Oscillator, which generates an 80ms pulse at 121khz.
- This pulse is picked up by the Heart Rate Receiver circuit for processing.

2.6 Schematics

1219

Transmitter Board
(USE TOSHIBA TC4001BPN)

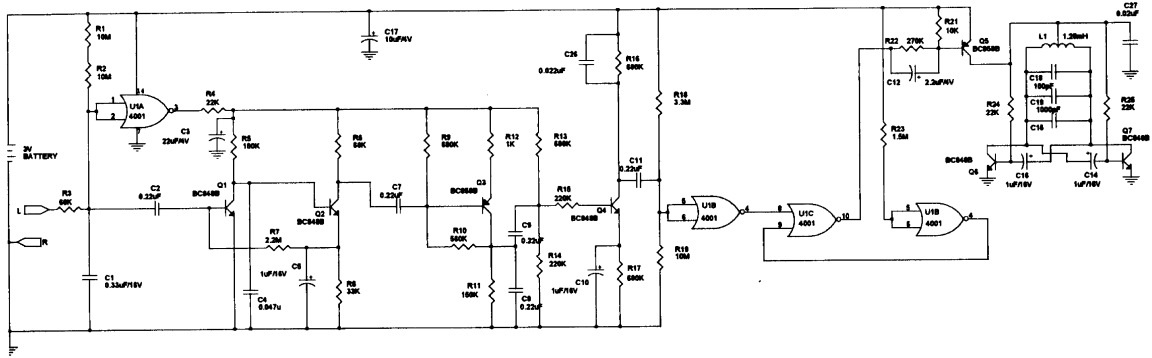

Artwork

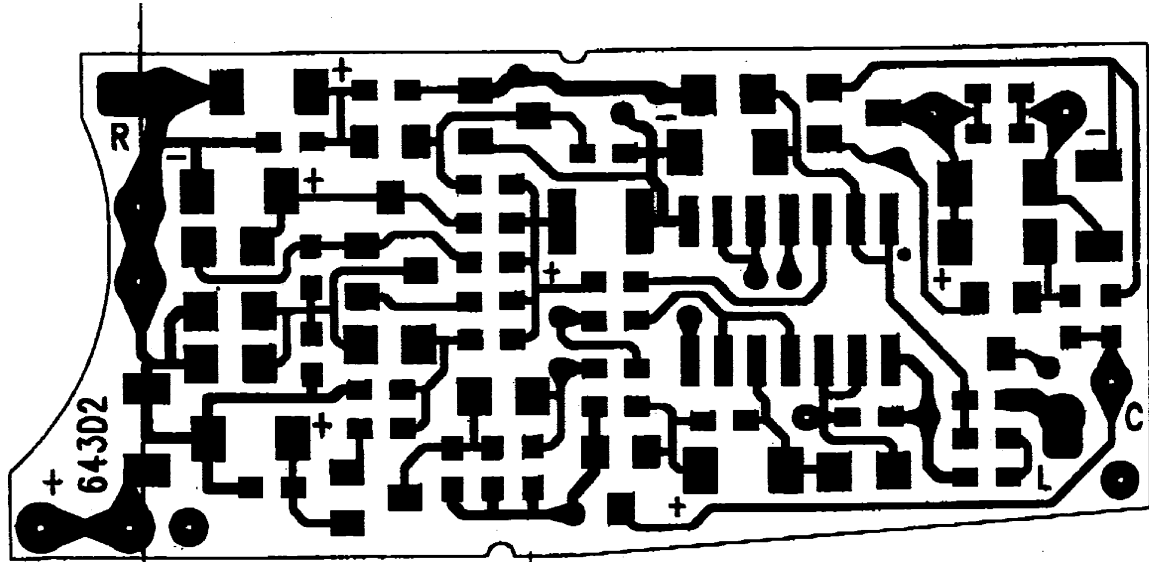

TOP LAYER

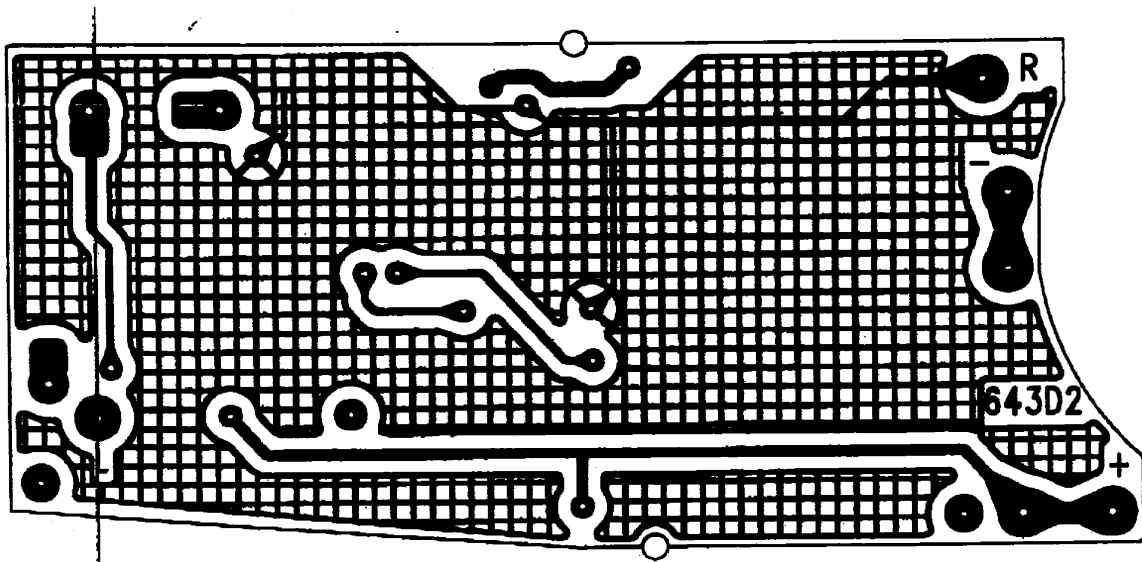

BOTTOM LAYER

PDF File. See the attachment that was electronically submitted.

2.7 Photograph of EUT - per 2.1033(b)(7)

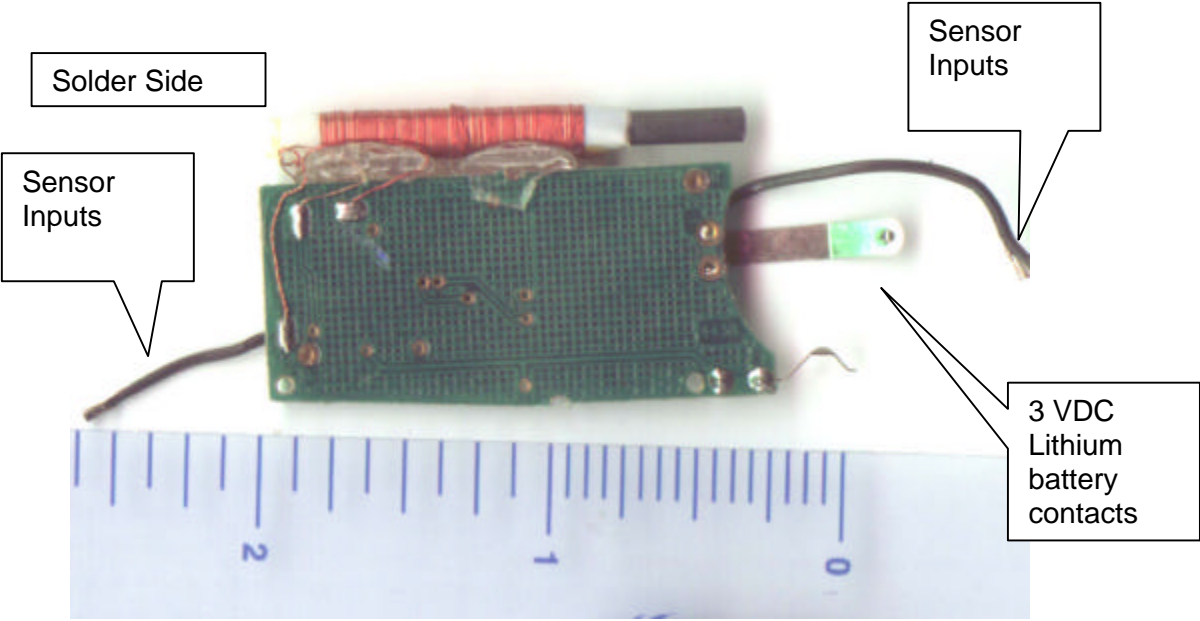
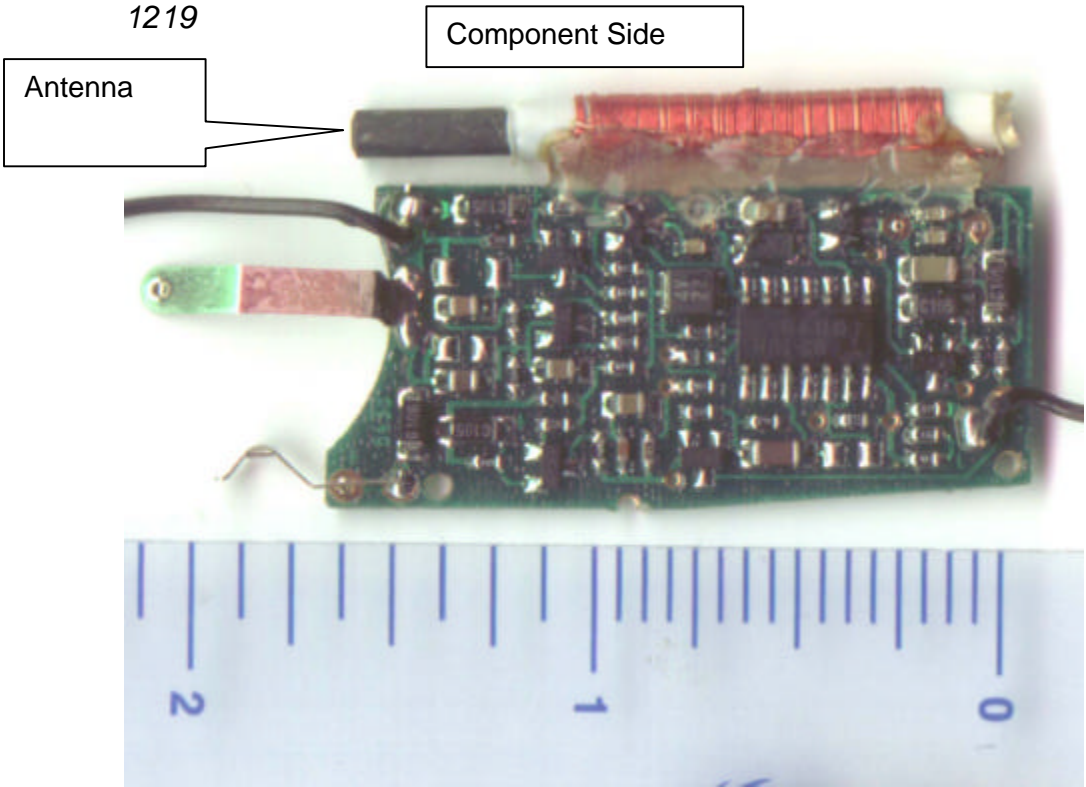

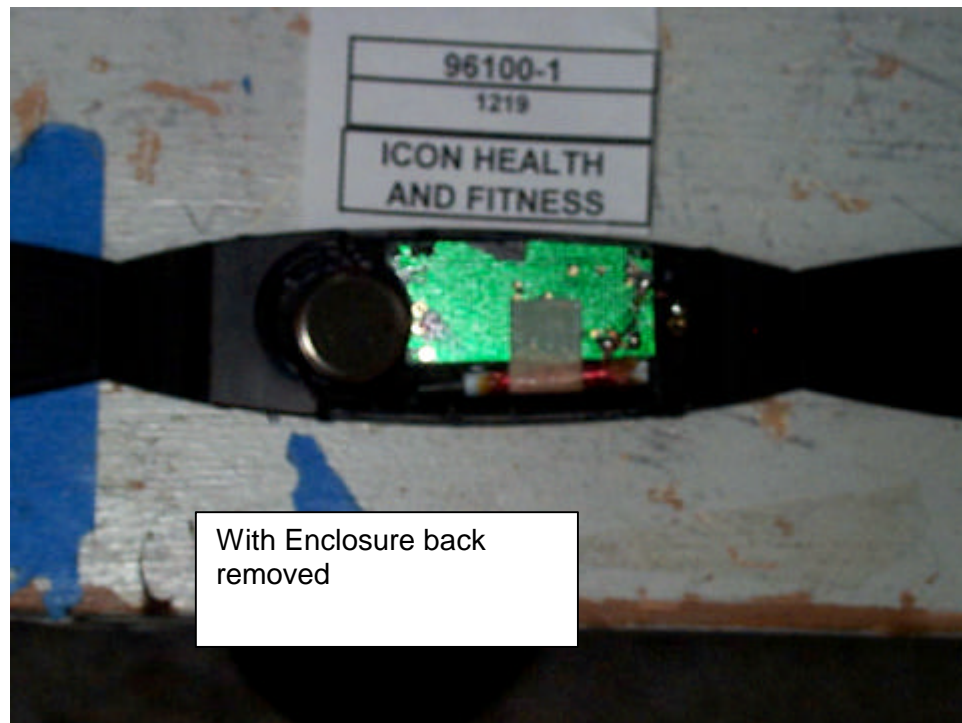
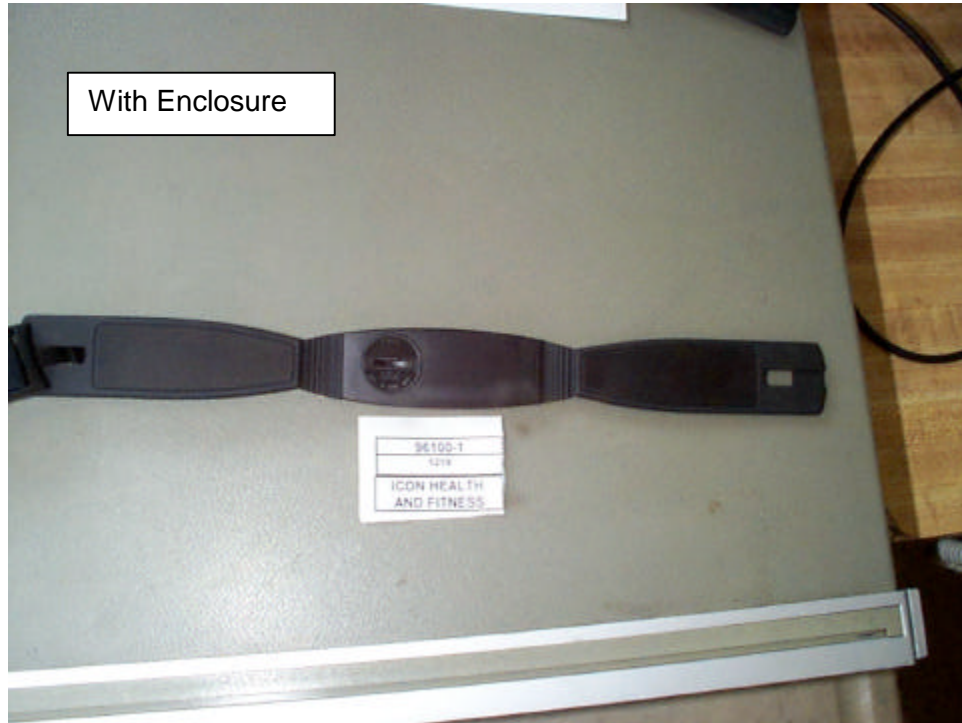

3.

EMISSIONS FCC PART 15

per FCC part 15 Subpart C

3.1 Radiated Emissions Test Setup and Procedure - Per 2.1033(b)(6) Per 2.947(a)

The EUT was placed on a wooden table 1 meter wide and 1.5 meters long which rests on a flush mounted, steel-top turntable on the open area test site as shown in Section 3.1.1.1. The top of the table is 80 cm above the ground plane. The turn-table can be rotated 360 degrees. Measuring antenna is set at the prescribed distance. Measurements are made with broad band antennas that have been correlated with tuned dipole antennas. The mast is 4.5 meters high and is self-supporting. The height of the antenna can be varied from 1 to 4 meters. Positioning of the antenna is controlled remotely.

3.1.1 Spurious Radiation Test Site Per 2.1033(b)6

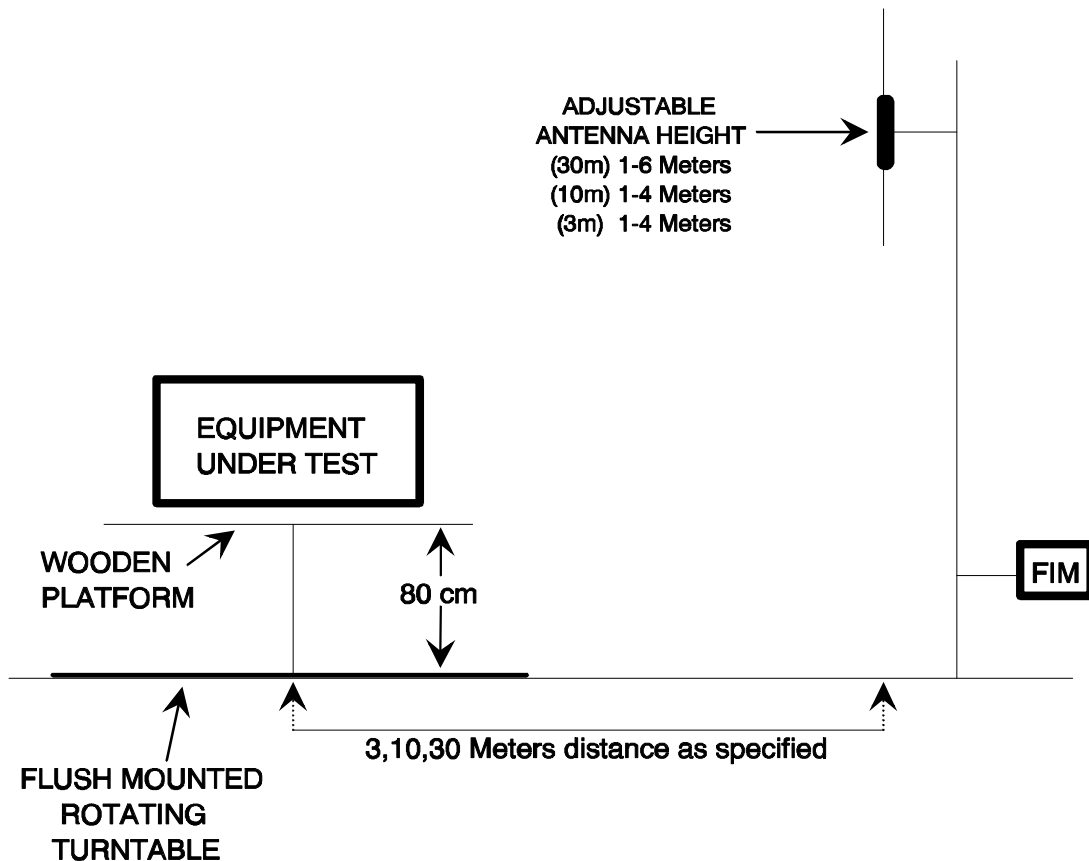

Radiated Test Setup and Procedure - cont'd

The EUT is put into the operational test mode as stated in Section 2.2.1 is then started.

The spectrum analyzer is setup to store the peak emission over the band of the antenna. Peak EUT and ambient emissions are stored while the turntable is rotated 360°. Peak spectrum analyzer trace is then plotted with the addition of antenna and cable correction factors. The limit is plotted on the same graph. A receiver with CISPR Quasi Peak capabilities is then used on the frequencies identified as the highest with respect to the plotted limit. Ambients are noted on the graph along with EUT emissions. The highest EUT frequencies, with respect to the limit, are maximized.

To maximize emissions levels, the turntable is rotated and the antenna is raised and lowered to determine the point of maximum emanations. The cables are then manipulated at that point to maximize emissions. Measurements are made with the antennas in each horizontal and vertical polarization separately. The data obtained from these tests is corrected with the proper cable, preamplifier and antenna factors. The results are then transcribed onto tables that show the maximum emission levels. The highest emissions are listed in a Radiated Emissions Summary table.

If no emissions can be found, the lowest harmonics of the EUT clocks within the bands of the standard are tuned into with the receiver. If no emissions are found, the noise floor will be entered into the table and noted. A minimum of six frequencies will be logged. Summary results will reflect only actual emissions from the EUT.

Radiated Test Setup and Procedure - contd.

The field intensity measurements are made using standard techniques with a spectrum analyzer or EMI receiver as the calibrated Field Intensity Meter (FIM). Preamplifiers and filters are used when required.

When using the Hewlett Packard Model 8568B Spectrum Analyzer as the FIM, the Analyzer is calibrated to read signal level in dBm. Where:

$$0 \text{ dBm (50 ohms)} = 107 \text{ dBuV (50 ohms)}$$

The signal level (dBuV) = indicated signal level (dBm) + 107 dB. To obtain the signal level in dBuV/m it is necessary to add the antenna factor in dB.

3.1.2 Example Of Typical Calculation Per 2.1033(b)6

Measurement Distance = 3 Meter			
Rohde and Schwarz reading @ 60 MHz			49.0 dBuV
Antenna Factor	+7.5 dBuV	→	
Cable Loss	+2.0 dBuV		
Preamplifier	-25.5 dBuV		
	-16.0 dBuV	→	-16.0 dBuV
Field Strength dBuV/m at 3 Meter =		→	33.0 dBuV

The Following FCC limits for acceptance were used:

0.009 MHz to 0.490 MHz 2400//F(kHz)
 and
 0.490 MHz to 1.705 MHz 24000/F(kHz)

Applied limit 121 kHz is 26.1 dB uV/m and 355 kHz is 16.6 dB uV/m

Per 15.31(f)(2) Extrapolation factor of 40 dB/decade for measurement distances different then specified in with limits for frequencies below 30 MHz.

Extrapolation for 300 meters limit distance to 10 measurement distance is 59 dB

3.1.3 Diagram of Test Setup - per 2.1033(b)5

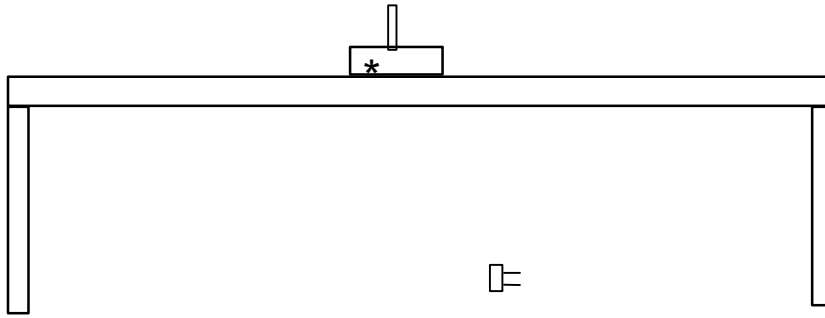

* - OBJECT OF TEST Horizontal

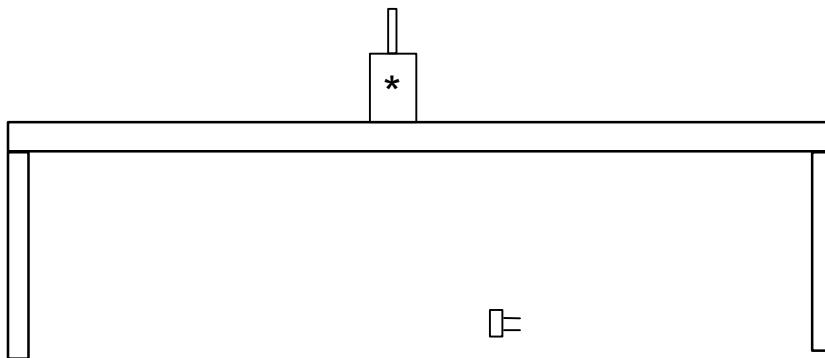

* - OBJECT OF TEST Vertical

3.1.4 Field Strength of Intentional Radiator Inside of Band

The EUT was compliant with CFR 47, 15.209(a) field strength of intentional radiator.

COMPANY EUT: 1219				
Transmitter Field Strength Configuration A Flat	Frequency MHz	Corrected Measurement (dBuV/m)	300 meter Limit (dBuV/m)	Delta (dB)
	0.121	5.6	26.1	-20.5

- Reference Appendix A for all data taken.
- Measurements taken at 10 meters and extrapolated to 300 as shown in section 3.1.2 of this report

3.1.5 Spurious Radiated Emissions

The EUT was compliant with CFR 47, 15.209(a) radiated emissions requirements.

per FCC part 15, Subpart C (15.209 (a)) at 300 meters

Table 3.1.5(1)

COMPANY: Icons Health and Fitness					EUT: 1219			
Freq. (MHz)	Meas'd (dBuV)	300 to 10 meter correction	Cable Factors (dB)	Antenna Factors (dB)	Total Factors (dB)	Corrected signal (dBuV/m)	300 Meter Limit (dBuV/m)	Delta (dB)
0.355	29.4	-59.0	0.2	20.2	-38.6	-9.2	16.6	-25.8

- Reference Appendix A for all data taken.
- Measurements taken at 10 meters and extrapolated to 300 as shown in section 3.1.2 of this report
- Only the third harmonic could be detected at 10 meters

3.1.6 *Photograph of Radiated Test Setup - per 2.1033(b)(7)*
121 kHz Heart Rate Transmitter



**3.2 Conducted Emissions Test Setup and Procedure - Per
2.1033(b)(6) Per 2.947(a)**

Not applicable. This device is operated only from a 3 V lithium battery.

4. LABELING REQUIREMENTS - PER 2.1033(B)(7)

Label will be constructed of 0.02 inch plastic attached as shown on the equipment with permanent adhesive.

All information on the label will be etched or screened. All methods will exceed the expected lifetime of the equipment.

The label will be large enough to allow all information to be readily legible.

4.1 Additional Label Required

<p><i>This device complies with Part 15 of the FCC Rules. Operation is subject to the following two conditions: (1) This device may not cause harmful interference, and (2) This device must accept any interference received, including interference that may cause undesired operation.</i></p>

Shown above is a copy of the label with the Part 15.19 Compliance Statement, Location of required information is checked "below".

- The label will be placed in a conspicuous location on the device.*
- The device is too small for a compliance label. Therefore the label will be placed in a prominent location in the Instruction Manual or other information supplied to the user.*
- The device is too small for a compliance label. The label will be placed on the container in which the device will be marketed.*

4.2 Photograph of Label Placement and Contents

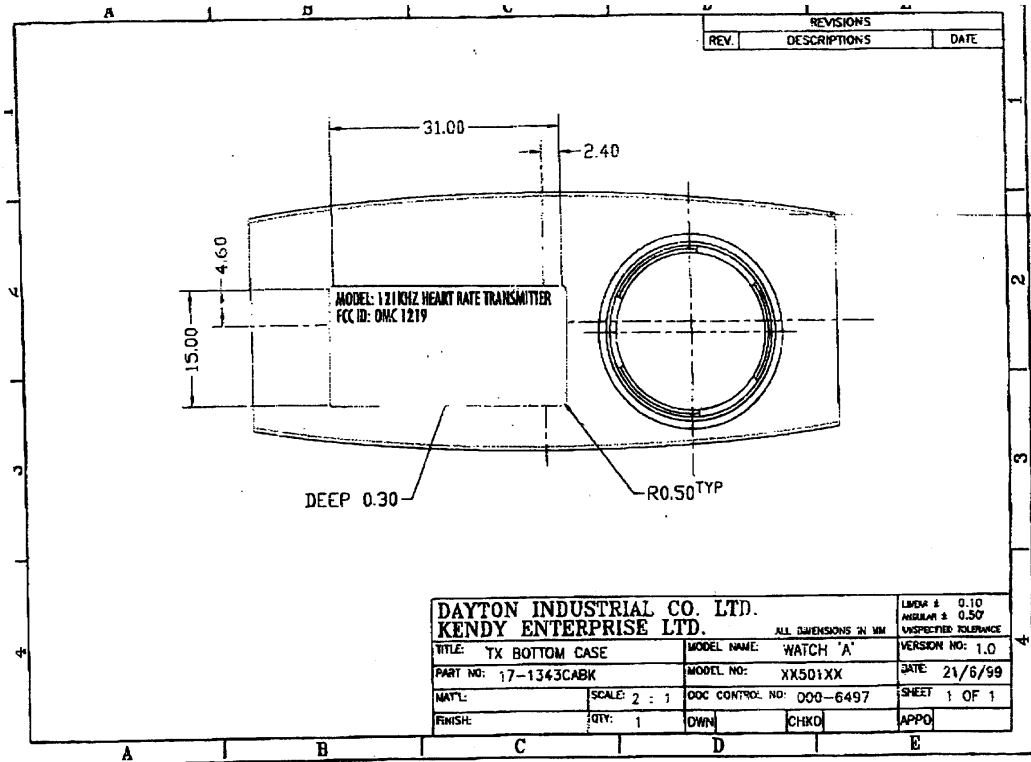

**MODEL: 121KHZ HEART RATE TRANSMITTER
 FCC ID: OMC 1219**

THIS DEVICE COMPLIES WITH PART 15 OF THE FCC RULES. OPERATION IS SUBJECT TO THE TWO FOLLOWING CONDITIONS:

(1) THIS DEVICE MAY NOT CAUSE HARMFUL INTERFERENCE, AND

(2) THIS DEVICE MUST ACCEPT ANY INTERFERENCE RECEIVED, INCLUDING INTERFERENCE THAT MAY CAUSE UNDESIRE OPERATION

PDF File. See the attachment that was electronically submitted.

5. OWNERS MANUAL

Chest Pulse Sensor User's Guide

To install and assemble the replacement chest pulse sensor, please read and follow all instructions in this user's guide. To use the chest pulse sensor with your treadmill, refer to the user's manual provided with your treadmill and the user's manual included with your original chest pulse sensor.

This device complies with Part 15 of the FCC rules. Operation is subject to the following two conditions: (1) this device may not cause harmful interference, and (2) this device must accept any interference received, including interference that may cause undesired operation.

Changes or modifications not expressly approved by ICON Health & Fitness, Inc. could void the user's authority to operate this device.

WARNING: If you have an implanted medical device such as a pacemaker, check with your physician before using the chest pulse sensor.

WARNING: If you have heart problems, or if you are over 60 years of age and have been inactive, do not use the pulse programs.
Note: Your treadmill model may not have pulse programs.

WARNING: If you are taking medication regularly, consult your physician to find whether the medication will affect your exercise heart rate.

PDF File. See the attachment that was electronically submitted.

6. APPENDIX SECTION

6.1 APPENDIX A: TEST DATA

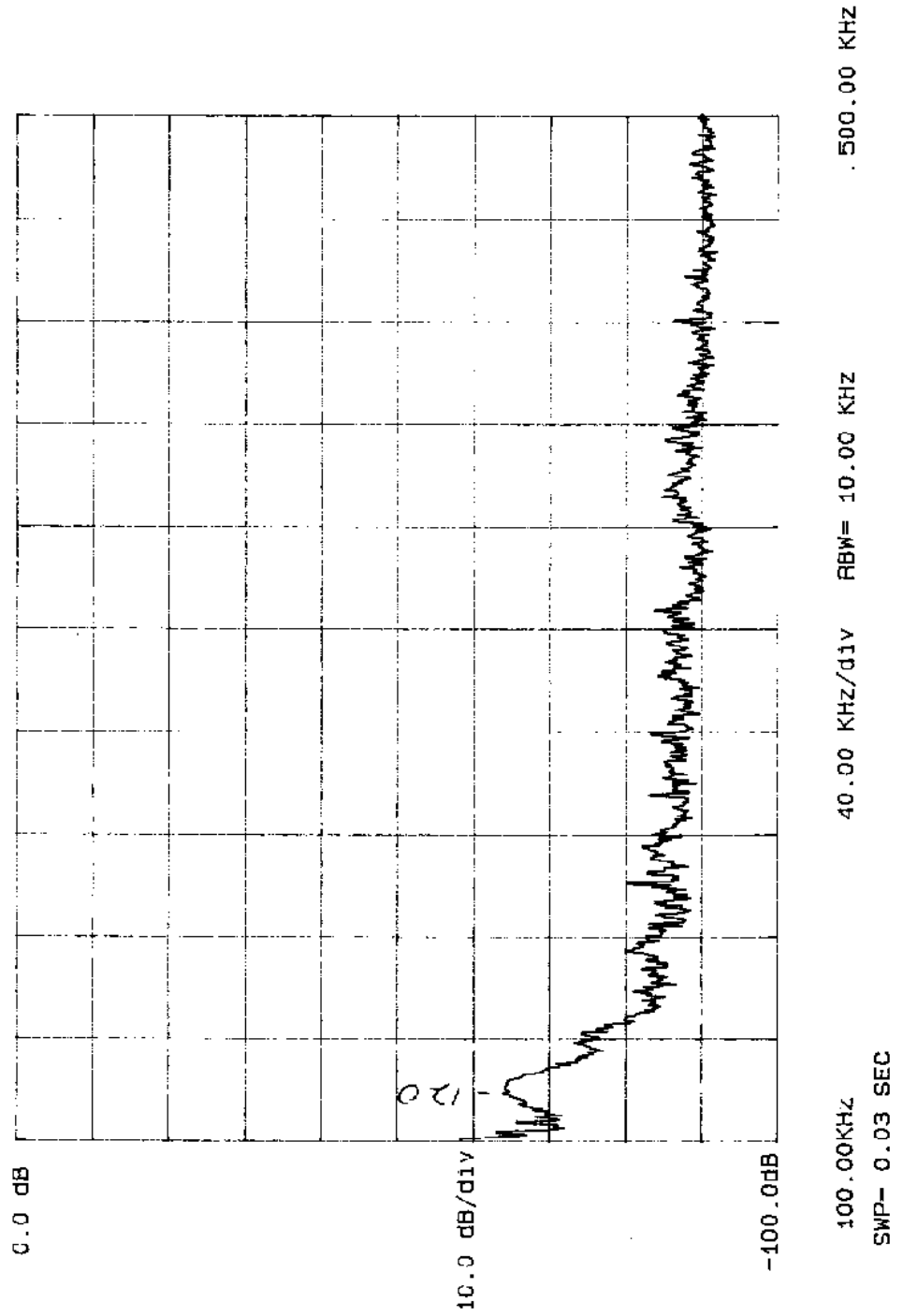

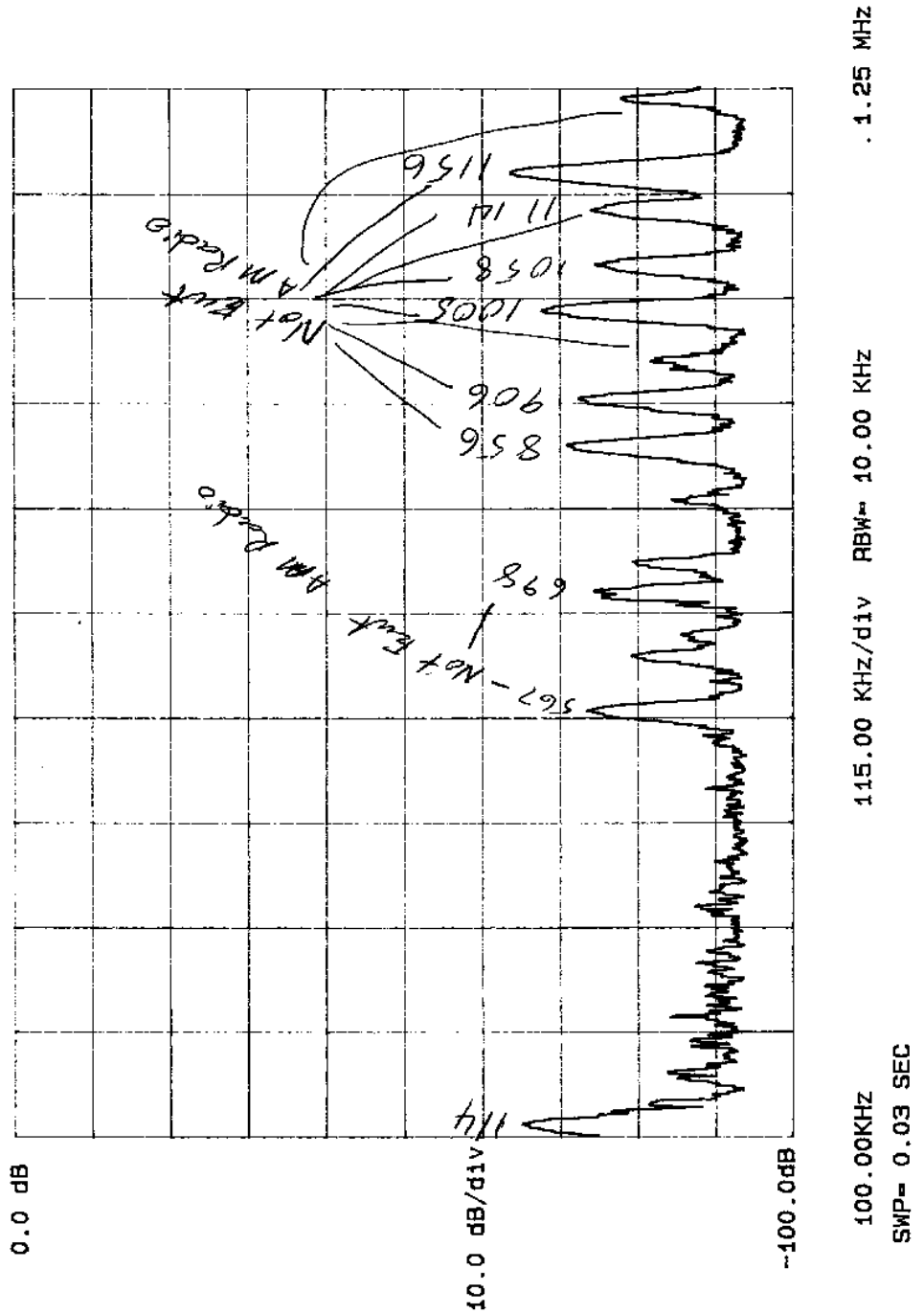

6.2 APPENDIX B: UNCERTAINTY TOLERANCE

UNCERTAINTY TOLERANCE

DNB Engineering's Utah Facility is within acceptable uncertainty tolerances per ANSI C63.4 (1992) sections 5.4.6.1 and 5.4.6.2 as well as CISPR 16-1(1993) Annex M, section M.2.

ANSI C63.4 (1992)

5.4.6.1 Site Attenuation. A measurement site shall be considered acceptable for radiated electromagnetic field measurements if the horizontal and vertical NSA derived from measurements, i.e., the "measured NSA," are within ± 4 dB of the theoretical NSA (5.4.6.3) for an ideal site.

5.4.6.1 NSA Tolerance. The ± 4 dB tolerance in 5.4.6.1 includes instrumentation calibration errors, measurement technique errors, and errors due to site anomalies. These errors are analyzed in ANSI C63.6-1988 [3], wherein it is shown that the performance of a well-built site contributes only 1 dB of the total allowable tolerance.

CISPR 16-1 (1993)

M.2 Error analysis

. . . The total estimated errors are the basis for the ± 4 dB site acceptability criterion consisting of approximately 3 dB measurement uncertainty and an additional allowable 1 dB for site imperfections.

***6.3 APPENDIX C: TEST SITE CERTIFICATION, CHALK CREEK
EMI SITE - per 2.948(a)***

SITE CHARACTERISTICS, CHALK CREEK EMI TEST SITE

General:

The DNB Engineering test facility is located in Chalk Creek Canyon near Coalville, Utah. Site characteristics were measured according to the procedures outlined in ANSI C63.4 (1992) "Characteristics of Open Field Test Site". The results of these characterizations indicate that the Chalk Creek site is an outstanding facility to perform accurate and repeatable EMI tests.

This facility has been FCC approved to perform class B certification testing since January, 1986. In October of 1996, according to the FCC requirement to re-apply every three years, the facility was recertified. Certification was granted for the 3, 10, and 30 meter positions for both ranges. Facility approval was granted by the FCC Oct. 15, 1996 under file number 31040/PRV 1300F2.

In July of 1997, **The American Association for Laboratory Accreditation, A2LA**, granted accreditation to this facility. Standards for which accreditation was granted: RF Emissions: ANSI C63.4 - 1992, FCC Part 15 subpart B and C, FCC Part 18 CISPR 11, CISPR 13, CISPR 14, CISPR 22, EN 55011, EN 55013, EN 55014, EN 55022, EN 60601-1-2, EN 50081-1, EN 50081-2, IEC 601-1-2; RF Immunity: EN 50082-1, EN 50082-2, Radiated Susceptibility: EN 61000-4-3, ENV 50140, ENV 50204, IEC 1000-4-3, IEC 801-3, ESD: EN 61000-4-2, IEC 1000-4-2, IEC 801-2, EFT: EN 61000-4-4, IEC 1000-4-4, IEC 801-4, Surge: EN 61000-4-5, ENV 50142, IEC 1000-4-5, IEC 801-5, Injected RF Immunity: EN 61000-4-6, ENV 50141, IEC 1000-4-6, IEC 801-6

In September, 1994 the National Certified Testing/Competent/ Notified Body for Norway and Scandinavian Countries (NEMKO) approved this test facility. DNB now offers the testing required for the CE Mark. **NEMKO EMC Laboratory Authorization No.: ELA 131** Standards for which accreditation was granted: RF Emission: EN 55011, EN 55022, EN 50081-1, EN 50081-2; RF Immunity: EN 50082-1, EN 50082-2

In September, 1994, the New Zealand Ministry of Commerce certified that DNB ENGINEERING, INC. EMC facilities meet their laboratory approval criteria for EMC testing and placed DNB ENGINEERING on their list of Ministry-Approved laboratories.

In August, 1995, VCCI certified that the Chalk Creek facility was acceptable to perform EMI test according to VCCI requirements. The certificate number is 715.

Ambient Emissions

Ambient emission measurements were made to determine the level of the ambient emanations at the DNB test facility. The results indicate that all ambient signals are below the FCC, and VCCI radiated emission limits or that each can easily be identified as an ambient signal.

6.4 APPENDIX D: EMC INSTRUMENTATION **AND MEASUREMENT EQUIPMENT**

All test equipment are calibrated by a certified metrology facility using standards traceable to NIST.

Each instrument is calibrated annually or more frequently if required.

Test Equipment for Emissions

Description	Manufacturer	Model	Serial	Cal. Due
CISPR Adapter site 2	HP	85650A	2043A00277	9/25/99
Spectrum Analyzer site 2	HP	8568B	1721A00113	9/23/99
RF/Preselector site 1 (ref. only)	HP	85685A	2724A00659	10/27/99
Receiver	R&S	ESH3	882399/025	3-19-2000
Spectrum Monitor	R&S	EZM(3)	880 487/037	
Loop Antenna	R&S	HFH2Z2	880665/040	15JUN00

6.5 APPENDIX E: INFORMATION SUPPLIED TO APPLICANT

INFORMATION PERTAINING TO EQUIPMENT MANUFACTURED AFTER COMPLIANCE TESTING

It is prudent that manufacturers have an established Quality Assurance program to spot check their products on a periodic basis, either based upon time or quantities produced. Obviously, a change in the engineering design should be sufficient justification for a re-test.

The Quality assurance test need not be formal Verification or Certification such as required during the initial production of the product. However, it should be sufficient in scope to assure that the EMI characteristics of the product have not changed to the degree that the product exceeds the FCC limits. If a new model of a product is produced, it must undergo full Verification or Certification testing and, in case of Certification, be filed with the FCC.

It is expected that the FCC will place greater emphasis and resources in spot checking commercially available products. If a product is found not to be compliant with the Limits specified in Part 15, Subpart B, the manufacturer will be subject to the appropriate penalties imposed by the Commission. The initial Certification or Verification is sufficient to justify initial production. The additional quality assurance testing performed is the manufacturer's responsibility to assure continued compliance.