

# TEST RESULT SUMMARY

## FCC PART 15 SUBPART C Section 15.245

MANUFACTURER'S NAME	New Japan Radio Co Ltd
NAME OF EQUIPMENT	X-band Doppler Module (MIC Type)
MODEL NUMBER	NJR4170
MANUFACTURER'S ADDRESS	1-1 Fukuoka 2-Chome, Kamifukuokashi Saitama 358-8510 Japan
TEST REPORT NUMBER	W9286
TEST DATE	21 June 1999

According to testing performed at TÜV Product Service Inc, the above-mentioned unit is in compliance with the electromagnetic compatibility requirements defined in FCC Part 15.

It is the manufacturer's responsibility to assure that additional production units of this model are manufactured with identical electrical and mechanical characteristics. Any modifications necessary for compliance made during testing on the above mentioned date(s) must be implemented in all production units for compliance to be maintained.

TÜV Product Service Inc, as an independent testing laboratory, declares that the equipment tested as specified above conforms to the requirements of FCC Part 15.

Date: 30 June 1999

Location: Taylors Falls MN  
USA

  
 R. M. Johnson  
 Test Technician *for RMS*

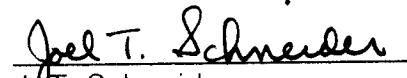
  
 J.T. Schneider  
 Reviewing Engineer

Not Transferable

# EMC EMISSION - TEST REPORT

Test Report File No. : WC1H928601 Date of issue: 30 June 1999

Model / Serial No. : NJR4170 / sample #1

Product Type : X-band Doppler Module (MIC Type)

Applicant : New Japan Radio Co Ltd

Manufacturer : New Japan Radio Co Ltd

License holder : New Japan Radio Co Ltd

Address : 1-1 Fukuoka 2-Chome, Kamifukuokashi  
 : Saitama 358-8510 Japan

Test Result :  Positive  Negative

Test Project Number Reference(s) : W9286

Total pages including Appendices : 20

*TÜV Product Service Inc is a subcontractor to TÜV Product Service, GmbH according to the principles outlined in ISO/IEC Guide 25 and EN 45001.*

*TÜV Product Service Inc reports apply only to the specific samples tested under stated test conditions. It is the manufacturer's responsibility to assure that additional production units of this model are manufactured with identical electrical and mechanical components. TÜV Product Service Inc shall have no liability for any deductions, inferences or generalizations drawn by the client or others from TÜV Product Service Inc issued reports.*

*This report is the confidential property of the client. As a mutual protection to our clients, the public and ourselves, extracts from the test report shall not be reproduced except in full without our written approval. This report shall not be used by the client to claim product endorsement by NVLAP or any agency of the US government.*

*TÜV Product Service Inc and its professional staff hold government and professional organization certifications and are members of AAMI, ACIL, AEA, ANSI, IEEE, NVLAP, and VCCI*

**DIRECTORY - EMISSIONS**

		Page(s)
<b>A) Documentation</b>		
Test report		<u>1 - 10</u>
Directory		<u>2</u>
Test Regulations		<u>3</u>
Deviation from standard / Summary		<u>10</u>
Test-setups (Photos)		<u>11 - 12</u>
Test-setup (drawing)		<u>Appendix A</u>
<b>B) Test data</b>		
Conducted emissions	10/150 kHz - 30 MHz	<u>5, 9</u>
Radiated emissions	10 kHz - 30 MHz	<u>5, 9</u>
Radiated emissions	30 MHz - 1000 MHz	<u>6, 9</u>
Interference power	30 MHz - 300 MHz	<u>6, 9</u>
Equivalent Radiated emissions	1 GHz - 18 GHz	<u>7, 9</u>
<b>C) Appendix A</b>		
Test Data Sheets and Test Setup Drawing(s)		<u>A2 -A3</u>
<b>D) Appendix B</b>		
Constructional Data Form		<u>B2</u>
Product Information Form(s)		<u>B3</u>
<b>E) Appendix C</b>		
Measurement Protocol		<u>C1 - C2</u>

**EMISSIONS TEST REGULATIONS :**

The emissions tests were performed according to following regulations:

- |  |   |                                    |
|--|---|------------------------------------|
| <input type="checkbox"/> - EN 50081-1 / 1991                               | <input type="checkbox"/> - Group 1                          | <input type="checkbox"/> - Group 2 |
| <input type="checkbox"/> - EN 55011 / 1991                                 | <input type="checkbox"/> - Class A                          | <input type="checkbox"/> - Class B |
| <input type="checkbox"/> - EN 55013 / 1990                                 | <input type="checkbox"/> - Household appliances and similar |                                    |
| <input type="checkbox"/> - EN 55014 / 1987                                 | <input type="checkbox"/> - Portable tools                   |                                    |
|  | <input type="checkbox"/> - Semiconductor devices            |                                    |
| <input type="checkbox"/> - EN 55014 / A2:1990                              | <input type="checkbox"/> - Household appliances and similar |                                    |
| <input type="checkbox"/> - EN 55014 / 1993                                 | <input type="checkbox"/> - Portable tools                   |                                    |
|  | <input type="checkbox"/> - Semiconductor devices            |                                    |
| <input type="checkbox"/> - EN 55015 / 1987                                 |   |                                    |
| <input type="checkbox"/> - EN 55015 / A1:1990                              |   |                                    |
| <input type="checkbox"/> - EN 55015 / 1993                                 |   |                                    |
| <input type="checkbox"/> - EN 55022 / 1987                                 | <input type="checkbox"/> - Class A                          | <input type="checkbox"/> - Class B |
| <input type="checkbox"/> - EN 55022 / 1994                                 | <input type="checkbox"/> - Class A                          | <input type="checkbox"/> - Class B |
| <input type="checkbox"/> - BS  |   |                                    |
| <input type="checkbox"/> - VCCI  | <input type="checkbox"/> - Class A                          | <input type="checkbox"/> - Class B |
| <input checked="" type="checkbox"/> - FCC Part 15 Subpart C Section 15.245 |   |                                    |
| <input type="checkbox"/> - AS 3548 (1992)                                  | <input type="checkbox"/> - Class A                          | <input type="checkbox"/> - Class B |
| <input type="checkbox"/> - CISPR 11 (1990)                                 | <input type="checkbox"/> - Group 1                          | <input type="checkbox"/> - Group 2 |
|  | <input type="checkbox"/> - Class A                          | <input type="checkbox"/> - Class B |
| <input type="checkbox"/> - CISPR 22 (1993)                                 | <input type="checkbox"/> - Class A                          | <input type="checkbox"/> - Class B |

**Environmental conditions in the lab:**

	<u>Actual</u>
Temperature	: 24 °C
Relative Humidity	: 56 %
Atmospheric pressure	: 98.5 kPa
Power supply system	: +5 VDC

**Sign Explanations:**

- not applicable
- applicable

**Emissions Test Conditions: CONDUCTED EMISSIONS (Interference Voltage)**

The *CONDUCTED EMISSIONS (INTERFERENCE VOLTAGE)* measurements were performed at the following test location:

- Test not applicable

- Wild River Lab Large Test Site (Open Area Test Site)
- Wild River Lab Small Test Site (Open Area Test Site)
- Oakwood Lab (Open Area Test Site)
- Wild River Lab Screen Room
- New Brighton Lab Shielded Room

**Test equipment used :**

Model Number	Manufacturer	Description	Serial Number	Cal Date
--------------	--------------	-------------	---------------	----------

Use of the calibrated equipment on this list ensures traceability to national and international standards.

**Emissions Test Conditions: RADIATED EMISSIONS (Magnetic Field)**

The *RADIATED EMISSIONS (MAGNETIC FIELD)* measurements were performed at the following test location:

- Wild River Lab Large Test Site (Open Area Test Site)
- Wild River Lab Small Test Site (Open Area Test Site)
- Oakwood Lab (Open Area Test Site)

**at a test distance of :**

- 3 meters
- 10 meters
- 30 meters

- Test not applicable

**Test equipment used :**

Model Number	Manufacturer	Description	Serial Number	Cal Date
--------------	--------------	-------------	---------------	----------

**Emissions Test Conditions: RADIATED EMISSIONS (Electric Field)**

The *RADIATED EMISSIONS (ELECTRIC FIELD)* measurements, in the frequency range of 30 MHz-1000 MHz, were tested in a horizontal and vertical polarization at the following test location :

- Test not applicable

- Wild River Lab Large Test Site (Open Area Test Site)
- Wild River Lab Small Test Site (Open Area Test Site)
- Oakwood Lab (Open Area Test Site)

at a test distance of :

- 3 meters
- 10 meters
- 30 meters

Test equipment used :

Model Number	Manufacturer	Description	Serial Number	Cal Date
■ - 3146	Electro-Mechanics (EMCO)	Log Periodic Antenna	9103-3075	11-98
■ - 3108	Electro-Mechanics (EMCO)	Biconical Antenna	2118	11-98
■ - 8566B	Hewlett-Packard	Spectrum Analyzer	2221A01596	4-99
■ - 85662A	Hewlett-Packard	Analyzer Display	2152A03640	4-99
■ - 85650A	Hewlett-Packard	Quasi-Peak Adapter	2811A01127	4-99
■ - ZHL-1042J	Mini-Circuits	Preamplifier	H072294-11	3-99

Use of the calibrated equipment on this list ensures traceability to national and international standards.

**Emissions Test Conditions: INTERFERENCE POWER**

The *INTERFERENCE POWER* measurements were performed by using the absorbing clamp on the mains and interface cables in the frequency range 30 MHz - 300 MHz at the following test location :

- Test not applicable

- Wild River Lab Large Test Site (Open Area Test Site)
- Wild River Lab Small Test Site (Open Area Test Site)
- Oakwood Lab (Open Area Test Site)
- Wild River Lab Screen Room
- New Brighton Lab Shielded Room

Test equipment used :

Model Number	Manufacturer	Description	Serial Number	Cal Date
--------------	--------------	-------------	---------------	----------

## Emissions Test Conditions: RADIATED EMISSIONS (Electric Field)

The *EQUIVALENT RADIATED EMISSIONS* measurements in the frequency range 1 GHz - 52.625 GHz were performed in a horizontal and vertical polarization at the following test location :

- Wild River Lab Large Test Site (Open Area Test Site)
- Wild River Lab Small Test Site (Open Area Test Site)
- Oakwood Lab (Open Area Test Site)
- Wild River Lab Screen Room

at a test distance of:

- 1 meters
- 3 meters
- 10 meters

- Test not applicable

Test equipment used :

Model Number	Manufacturer	Description	Serial Number	Cal Date
<input checked="" type="checkbox"/> - 3115	Electro-Mechanics (EMCO)	Horn Antenna	9001-3275	9-98
<input checked="" type="checkbox"/> - 3116	Electro-Mechanics (EMCO)	Horn Antenna	2005	10-98
<input checked="" type="checkbox"/> - 19-7025	Aerowave Inc	Standard Gain Horn Antenna	n/a	n/a
<input checked="" type="checkbox"/> - 8566B	Hewlett-Packard	Spectrum Analyzer	2221A01596	4-99
<input checked="" type="checkbox"/> - 85662A	Hewlett-Packard	Analyzer Display	2152A03640	4-99
<input checked="" type="checkbox"/> - 85650A	Hewlett-Packard	Quasi-Peak Adapter	2811A01127	4-99
<input checked="" type="checkbox"/> - ZHL-1042J	Mini-Circuits	Preamplifier	H072294-11	3-99
<input checked="" type="checkbox"/> - AWT-18037	Avantek	Preamplifier	1001-9226	3-99
<input checked="" type="checkbox"/> - AFT-8434	Avantek	Preamplifier	9112 Z221	3-99
<input checked="" type="checkbox"/> - 11975A	Hewlett-Packard	Amplifier	2738A01200	7-98
<input checked="" type="checkbox"/> - 11970K	Hewlett-Packard	Harmonic Mixer	2332A01170	11-96
<input checked="" type="checkbox"/> - 11970A	Hewlett-Packard	Harmonic Mixer	2332A01861	11-96
<input checked="" type="checkbox"/> - 11970U	Hewlett-Packard	Harmonic Mixer	3003A01395	10-96

Use of the calibrated equipment on this list ensures traceability to national and international standards.



**Equipment Under Test (EUT) Test Operation Mode - Emission tests :**

The device under test was operated under the following conditions during emissions testing:

- Standby
- Test program (H - Pattern)
- Test program (color bar)
- Test program (customer specific)
- Practice operation
- Normal Operating Mode
- Transmitter on.

**Configuration of the device under test:**

- See Constructional Data Form in Appendix B - Page B2
- See Product Information Form in Appendix B - beginning on Page B3

The following peripheral devices and interface cables were connected during the measurement:

- |                                  |              |
|----------------------------------|--------------|
| <input type="checkbox"/> - _____ | Type : _____ |
| <input type="checkbox"/> - _____ | Type : _____ |
| <input type="checkbox"/> - _____ | Type : _____ |
| <input type="checkbox"/> - _____ | Type : _____ |
| <input type="checkbox"/> - _____ | Type : _____ |
| <input type="checkbox"/> - _____ | Type : _____ |
| <input type="checkbox"/> - _____ | Type : _____ |
| <input type="checkbox"/> - _____ | Type : _____ |

- unshielded power cable
- unshielded cables
- shielded cables
- customer specific cables

MPS.No.: \_\_\_\_\_

- \_\_\_\_\_
- \_\_\_\_\_

**Emission Test Results:**

**Conducted emissions 10/150 kHz - 30 MHz**

The requirements are  - MET  - NOT MET  
 Minimum limit margin \_\_\_\_\_ dB at \_\_\_\_\_ MHz  
 Maximum limit exceeding \_\_\_\_\_ dB at \_\_\_\_\_ MHz  
 Remarks: \_\_\_\_\_

**Radiated emissions (magnetic field) 10 kHz - 30 MHz**

The requirements are  - MET  - NOT MET  
 Minimum limit margin for fundamental \_\_\_\_\_ dB at \_\_\_\_\_ kHz  
 Minimum limit margin for spurious \_\_\_\_\_ dB at \_\_\_\_\_ kHz  
 Remarks: \_\_\_\_\_

**Radiated emissions (electric field) 30 MHz - 1000 MHz**

The requirements are  - MET  - NOT MET  
 Minimum limit margin for fundamental \_\_\_\_\_ dB at \_\_\_\_\_ MHz  
 Minimum limit margin for spurious \_\_\_\_\_ >10 dB at \_\_\_\_\_ MHz  
 Remarks: \_\_\_\_\_

**Interference Power at the mains and interface cables 30 MHz - 300 MHz**

The requirements are  - MET  - NOT MET  
 Minimum limit margin \_\_\_\_\_ dB at \_\_\_\_\_ MHz  
 Maximum limit exceeding \_\_\_\_\_ dB at \_\_\_\_\_ MHz  
 Remarks: \_\_\_\_\_

**Equivalent Radiated emissions 1 GHz - 52.625 GHz**

The requirements are  - MET  - NOT MET  
 Minimum limit margin for fundamental \_\_\_\_\_ 12 dB at \_\_\_\_\_ 10.525 GHz  
 Minimum limit margin for harmonics/spurious \_\_\_\_\_ 4 dB at \_\_\_\_\_ 31.575 GHz  
 Remarks: The level at 10.525 GHz is 116 dBuV/m (630.9 mV/m) at a distance of 3 meters. The limit is 128 dBuV/m (2500 mV/m). The highest level harmonic was measured at 31.575 GHz to be 84 dBuV/m (15.8 mV/m) compared to a limit of 88 dBuV/m (25 mV/m).

**DEVIATIONS FROM STANDARD:**

None.

**GENERAL REMARKS:**

**SUMMARY:**

The requirements according to the technical regulations are

- met

- not met.

The device under test does

- fulfill the general approval requirements mentioned on page 3.

- not fulfill the general approval requirements mentioned on page 3.

Testing Start Date: 21 June 1999

Testing End Date: 21 June 1999

- TÜV PRODUCT SERVICE INC -

Joel T. Schneider  
J. T. Schneider  
Reviewing Engineer

Thomas K Swanson  
Tested By:  
R. M. Johnson *for RMJ*

Test-setup photo(s):  
Conducted emission 10/150 kHz - 30 MHz

Not Applicable



Test-setup photo(s):  
Radiated emission 30 MHz - 52.625 GHz

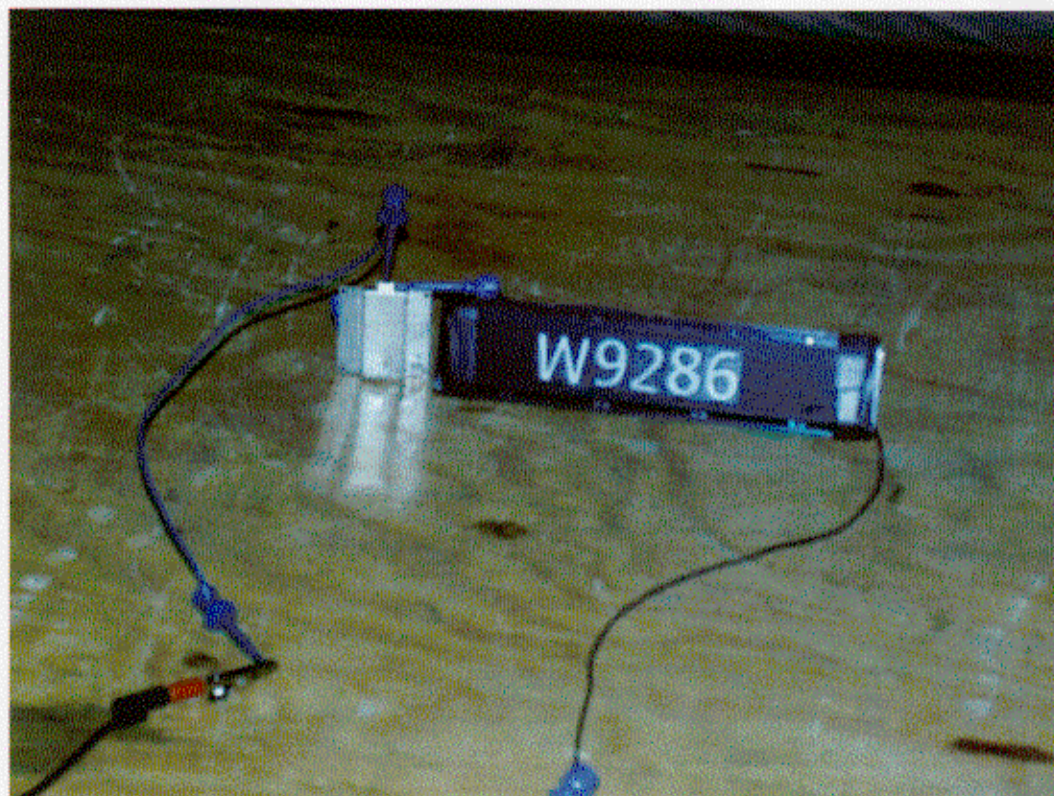
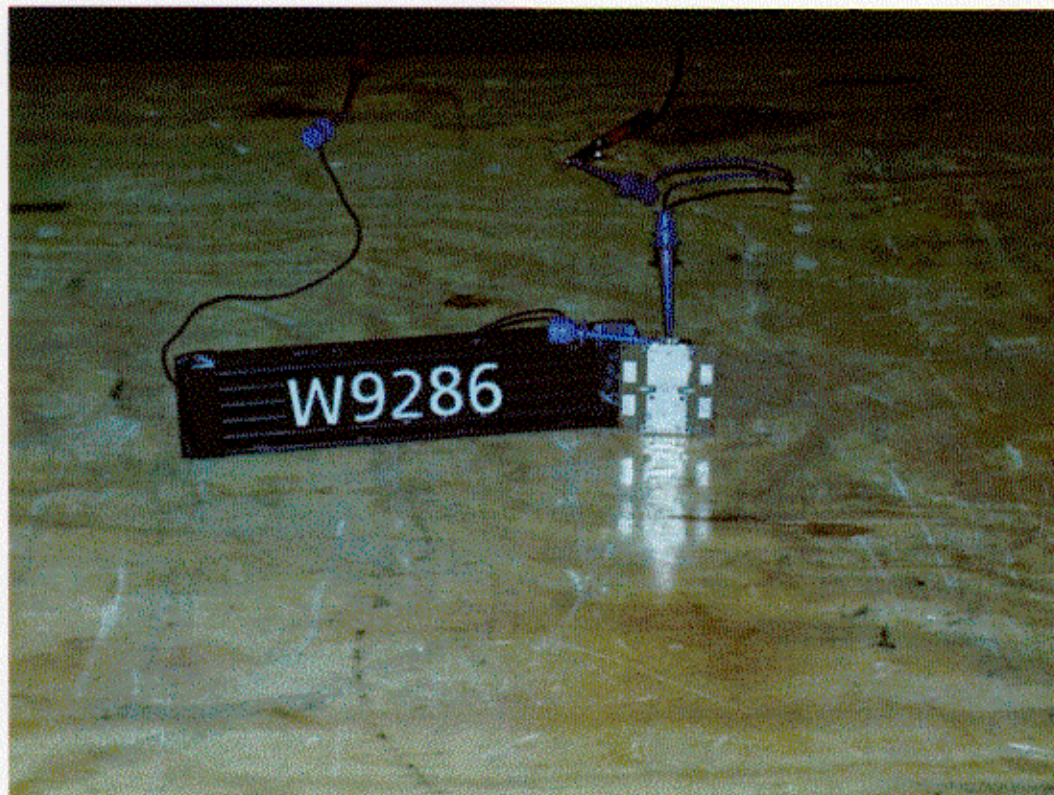



Appendix A

Test Data Sheets  
and  
Test Setup Drawing(s)

**TEST SETUP FOR EMISSIONS TESTING**

WILD RIVER LAB  
Large Test Site

Notes:

1. Items shown in dotted lines are located on the floor below the test area. It is 5 meters vertically from the ground floor to the test area.
2. 50 Hz, 60 Hz, and 400 Hz are power panels for alternating current.
3. The antenna may be positioned horizontally 3, 10 or 30 meters from the center of the turntable.
4. The circle is a 6.7 meter diameter turntable.
5. A ground plane is in the plane of this sheet.
6. The test sample is shown in the azimuthal position representing zero degrees.

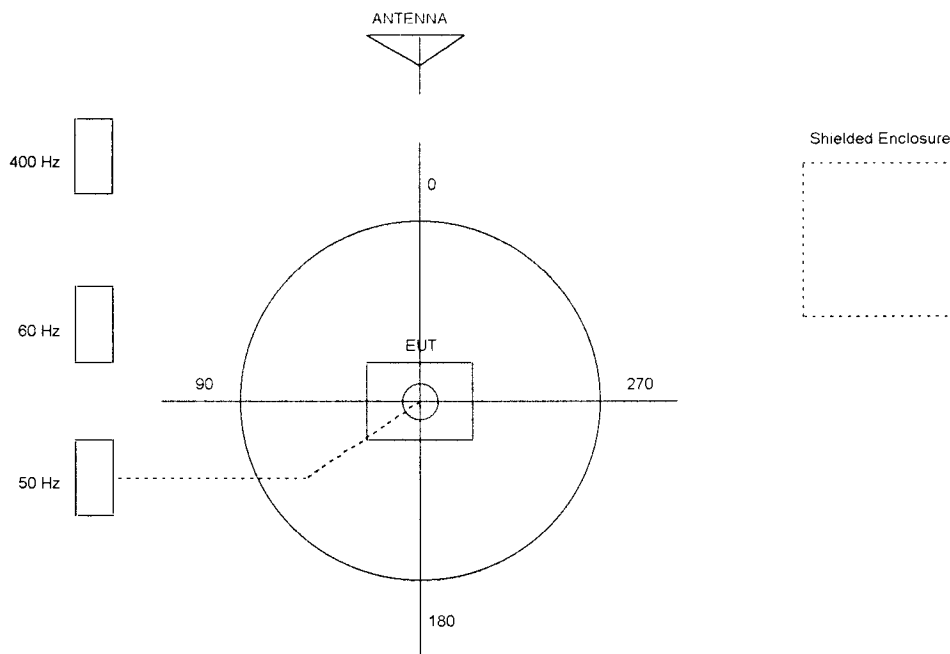

T U V P R O D U C T S E R V I C E

RADIATED EMISSIONS

Large Test Site  
 1/3 Meter Antenna Distance  
 Equipment Under Test:  
 NEW JRC  
 NJR4170 TRANSMITTER  
 Notes:

Report W9286 Run 1  
 Date 06-21-99 Page 1  
 Engineer \_\_\_\_\_  
 Tech: RMJ \_\_\_\_\_  
 Requester \_\_\_\_\_

Frequency MHz	Level dBuV	Factor dB	Cable dB	Peak dBuV/m	Ant Pol	ANTENNA DISTANCE	Limit dBuV/m
10525	70	39	7	116	H	3 M	128
10525	60	39	7	106	V	3 M	128
1 MHz RBW - PEAK - NO PREAMP - MAXIMUM OFF OF FRONT OF EUT - 1-4 METERS HIGH 360 DEGREES - EUT LONG SIDE UP (POWER LEADS OFF TOP OF EUT)							
10525	66	39	7	112	V	3 M	128
10525	62	39	7	108	H	3 M	128
1 MHz RBW - PEAK - NO PREAMP - MAXIMUM OFF OF FRONT OF EUT - 1-4 METERS HIGH 360 DEGREES - EUT SHORT SIDE UP (POWER LEADS OFF SIDE OF EUT)							
21500	41	44		85		1 M	98
31575	47	48		95		1 M	98
31575	36	48		84		3 M	88
42100	39	37		76		1 M	98
52625	30	39		69		1 M	98 (NOISE LEVEL)

NO SPURIOUS EMISSIONS DETECTED.



Appendix B

Constructional Data Form  
and  
Product Information Form(s)

Constructional Data Form

Not Applicable

X-band Doppler Module (MIC Type)

MODEL NO. NJR4170

<Description>

This specification covers the general requirements for microwave doppler module. This module is designed for motion sensing applications. This module consists of DRO (Dielectric Resonator Oscillator), balanced Schottky Barrier Diode mixer and Micro-strip Patch Antennas.

<Specifications>

<b>Electrical Characteristics ( at 25 degree C, +5 VDC)</b>	<b>Specifications</b>
Operating Voltage	5.0 +/- 0.2 VDC
Operating Current	30 mA typ.
Center Frequency	10.525 GHz +/- 5 MHz
Output Power	8 mW E.I.R.P. typ.
Return Loss Sensitivity	-90 dBc
Second Harmonic Emission	<25 mV/m (at 3 m)
Antenna Beamwidth (-3 dB)	E-Plane 36 deg. / H-Plane 72 deg.
<b>Pulse Mode Operation</b>	<b>Specifications</b>
Pulse Width	5 microsec.
Duty Cycle	0.01
<b>Absolute Maximum Ratings</b>	<b>Specifications</b>
DC Input Voltage	+8 VDC
Operating Temperature Range	-30 to +70 degree C
Storage Temperature Range	-40 to +80 degree C

Customer claims intended for indoor use.

Appendix C

**MEASUREMENT PROTOCOL**

**GENERAL INFORMATION**

Measurement Uncertainty

The test system for conducted emissions is defined as the LISN, tuned receiver or spectrum analyzer, and coaxial cable. The test system for radiated emissions is defined as the antenna, the pre-amplifier, the spectrum analyzer and the coaxial cable. These test systems have a measurement uncertainty of ±4.5 dB. The equipment comprising the test systems are calibrated on an annual basis.

Justification

The Equipment Under Test (EUT) is configured in a typical user arrangement in accordance with the manufacturer's instructions. A cable is connected to each available port and either terminated with a peripheral into its characteristic impedance or left unterminated. When appropriate, the cables are manually manipulated with respect to each other to obtain maximum emissions from the unit.

**CONDUCTED EMISSIONS**

The final level, expressed in dBμV, is arrived at by taking the reading directly from the EMI receiver. This level is compared directly to the FCC limit.

To convert between dBμV and μV, the following conversions apply:

$$\begin{aligned} \text{dB}\mu\text{V} &= 20(\log \mu\text{V}) \\ \mu\text{V} &= \text{Inverse log}(\text{dB}\mu\text{V}/20) \end{aligned}$$

**RADIATED EMISSIONS**

The final level, expressed in dBμV/m, is arrived at by taking the reading from the spectrum analyzer (Level dBμV) and adding the antenna correction factor and cable loss factor (Factor dB) to it. This result then has the FCC limit subtracted from it to provide the Delta which gives the tabular data as shown in the data sheets in Attachment B. The amplifier gain is automatically accounted for by using an analyzer offset.

Example:

Frequency (MHz)	Level (dBμV)	+	Factor & Cable (dB)	=	Final (dBμV/m)	-	FCC B Limit (dBμV/m)	=	Delta FCC B (dB)
32.21	13.9	+	16.3	=	30.2	-	40.0	=	-9.8

**DETAILS OF TEST PROCEDURES****General Standard Information**

The test methods used comply with ANSI C63.4-1992 - "Methods of Measurement of Radio-Noise Emissions from Low-Voltage Electrical and Electronic Equipment in the Range of 9 kHz to 40 GHz."

**Conducted Emissions**

Conducted emissions on the 60 Hz power interface of the EUT are measured in the frequency range of 450 kHz to 30 MHz. The measurements are performed using a receiver, which has CISPR characteristic bandwidth and quasi-peak detection, and a Line Impedance Stabilization Network (LISN), with 50  $\Omega$ /50  $\mu$ H (CISPR 16) characteristics. Table top equipment is placed on a non-conducting table 80 centimeters above the floor and is positioned 40 centimeters from the vertical ground plane (wall) of the screen room. In some cases, a pre-scan using a spectrum analyzer is initially performed on the units comprising the system under test to locate the highest emissions. If the minimum passing margin appears to be less than 20 dB with a peak mode measurement, the emissions are re-measured using a tuned receiver or spectrum analyzer with quasi-peak and average detection and recorded on the data sheets.

**Radiated Emissions**

Radiated emissions from the EUT are measured in the frequency range of 30 to 52625 MHz using a spectrum analyzer and appropriate broadband linearly polarized antennas. Measurements between 30 MHz and 1000 MHz are made with 120 kHz/6 dB bandwidth and quasi-peak detection and measurements above 1000 MHz are made with a 1 MHz/6 dB bandwidth and peak detection. Table top equipment is placed on a 1.0 X 1.5 meter non-conducting table 80 centimeters above the ground plane. Floor standing equipment is placed directly on the turntable/ground plane. Interface cables that are closer than 40 centimeters to the ground plane are bundled in the center in a serpentine fashion so they are at least 40 centimeters from the ground plane. Cables to simulators/testers (if used in this test) are routed through the center of the table and to a screen room located outside the test area. The antenna is positioned 1 or 3 meters horizontally from the EUT. To locate maximum emissions from the test sample the antenna is varied in height from 1 to 4 meters, measurement scans are made with both horizontal and vertical antenna polarizations and the EUT are rotated 360 degrees. Intentional radiators are rotated through three orthogonal axes to determine the attitude that maximizes the emissions.