

## Table of Content

|       |   |    |
|-------|---|----|
| 1     | Generalities.....   | 2  |
| 1.1   | Introduction.....   | 2  |
| 1.1.1 | <i>Overview.....</i>  | 2  |
| 1.1.2 | <i>Aim of the document.....</i>                             | 2  |
| 1.2   | Services provided by the feature or equipment.....          | 2  |
| 1.3   | External Interfaces.....                                    | 3  |
| 1.4   | Terminology / Abbreviations.....                            | 6  |
| 1.5   | Related Documents.....                                      | 6  |
| 1.6   | Features.....   | 8  |
| 2     | General Requirements.....                                   | 8  |
| 2.1   | Standards.....  | 8  |
| 2.1.1 | <i>BT related certification.....</i>                        | 8  |
| 2.2   | Environmental requirements.....                             | 10 |
| 3     | General Description.....                                    | 10 |
| 3.1   | Bluetooth WLAN daughter board BT stack diagram.....         | 10 |
| 3.2   | Bluetooth WLAN daughter board bloc diagram.....             | 11 |
| 3.3   | Mechanical aspects.....                                     | 11 |
| 3.4   | Specification.....  | 15 |
| 4     | Detailed Technical Description.....                         | 17 |
| 4.1   | Electronic.....   | 17 |
| 4.1.1 | <i>RF solution to be implemented.....</i>                   | 17 |
| 4.1.2 | <i>Schematic.....</i>                                       | 18 |
| 4.1.3 | <i>BOM.....</i>   | 18 |
| 4.2   | Radio frequency.....  | 20 |
| 4.2.1 | <i>Antenna.....</i>   | 20 |
| 4.2.2 | <i>Immunity to external spurious and interferences.....</i> | 24 |
| 4.3   | Layout.....   | 24 |
| 4.3.1 | <i>BTWDB layout.....</i>                                    | 24 |
| 4.3.2 | <i>Place requirements of BTWDB on mainboard.....</i>        | 24 |
| 4.4   | <b>RF Module label: L-Label.....</b>                        | 25 |
| 4.4.1 | <i>L-Label characteristics.....</i>                         | 25 |
| 4.4.2 | <i>L-Label location.....</i>                                | 25 |
| 4.4.3 | <i>L-Label content.....</i>                                 | 25 |

# 1 Generalities

## 1.1 Introduction

### 1.1.1 Overview

The main objectives for this board, discussed also with the marketing are:

- Get lowest cost solution to enable BT and WLAN for a maximum of IP terminals
- Enable new usages like
  - The phone is seen as a carkit for a smartphone
  - The phone can exchange phonebook with a smartphone
  - The phone can support tags through BT Low Energy
  - The phone can support WLAN
- From R&D point of view:
  - The board must be small enough to be integrated easily into our ID.
  - The board must integrate the antenna to avoid a re-certification for each phone which would use it.

For this project, a pre-study has been done.

The choice is to do a daughter board with the module from AMPAK, with an integrated antenna on the layout (Printed antenna).

### 1.1.2 Aim of the document

A pre-study has been done, in order to define the best choices for the whole solution, going from antenna to the BT and WLAN management software in the phone.

This document is intended to give all the technical inputs in order to make a BTWDB daughter board which will be used on the Alcatel-Lucent Enterprise IP Phones.

A first step will be to use it on Pleiades phone, but we should care to make it possible to be used also on nextgen phones.

## 1.2 Services provided by the feature or equipment

The BTWDB will give a BT5.2 and WIFI connectivity to the product where it is mounted into. The main reasons of this daughter board are to have:

- A common function usable on several phones without the need of RF expertise and full Bluetooth + WLAN qualification
- A cost-effective solution

### 1.3 External Interfaces

The interface signals are listed hereafter:

| Pin num | Pin Name      | Type | Description  | Voltage |
|---------|---------------|------|--|---------|
| 1       | GND           | G    | Ground connections                                     |         |
| 2       | VBAT          | P    | Main power voltage source input                        | 3.3V    |
| 3       | WL_REG_ON     | I    | Power up/down internal regulators used by WiFi section |         |
| 4       | WL_INT        | O    | WLAN to wake-up HOST                                   |         |
| 5       | SDIO_DATA_2   | I/O  | SDIO data line 2                                       | 1.8V    |
| 6       | SDIO_DATA_3   | I/O  | SDIO data line 3                                       | 1.8V    |
| 7       | SDIO_DATA_CMD | I/O  | SDIO command line                                      | 1.8V    |
| 8       | GND           | G    | Ground connections                                     |         |
| 9       | SDIO_DATA_CLK | I/O  | SDIO clock line  | 1.8V    |
| 10      | GND           | G    | Ground connections                                     |         |
| 11      | SDIO_DATA_0   | I/O  | SDIO data line 0                                       | 1.8V    |
| 12      | SDIO_DATA_1   | I/O  | SDIO data line 1                                       | 1.8V    |
| 13      | GND           | G    | Ground connections                                     |         |
| 14      | VDDIO         | P    | I/O Voltage supply input                               | 1.8V    |
| 15      | GND           | G    | Ground connections                                     |         |
| 16      | BT_CLK        | I    | External Low Power Clock input (32.768KHz)             | 1.8V    |
| 17      | GND           | G    | Ground connections                                     |         |
| 18      | BT_REG_ON     | I    | Power up/down internal regulators used by BT section   | 1.8V    |
| 19      | BT_WAKE       | I    | HOST wake-up Bluetooth device                          | 1.8V    |
| 20      | BT_INT        | O    | Bluetooth device to wake-up HOST                       | 1.8V    |
| 21      | GND           | G    | Ground connections                                     |         |
| 22      | GND           | G    | Ground connections                                     |         |
| 23      | PCM_OUT       | O    | PCM Data output  | 1.8V    |
| 24      | PCM_CLK       | I/O  | PCM clock  | 1.8V    |
| 25      | GND           | G    | Ground connections                                     |         |
| 26      | PCM_IN        | I    | PCM data input   | 1.8V    |
| 27      | PCM_SYNC      | I/O  | PCM sync signal  | 1.8V    |
| 28      | GND           | G    | Ground connections                                     |         |
| 29      | UART_RTS_N    | O    | Bluetooth UART interface                               | 1.8V    |
| 30      | UART_TXD      | O    | Bluetooth UART interface                               | 1.8V    |
| 31      | UART_RXD      | I    | Bluetooth UART interface                               | 1.8V    |
| 32      | UART_CTS_N    | I    | Bluetooth UART interface                               | 1.8V    |
| 33      | GND           | G    | Ground connections                                     |         |

The VBAT pin can accept 3.3V +/- 5%. Typical value is 3.3V, but this depends on the motherboard.

Mainboard through UART bus to send HCI commands to activate Bluetooth function.

The UART is a standard 4-wire interface (RX, TX, RTS, and CTS) with adjustable baud rates from 9600 bps to 4.0 Mbps. The interface features an automatic baud rate detection capability that returns a baud rate selection. Alternatively, the baud rate may be selected through a vendor-specific UART HCI command

The UART has by default the following characteristics (can be reprogrammed to up to 4Mbps)

| Parameter   | Value      |
|-------------|------------|
| Bit rate    | 115.2 kbps |
| Data length | 8 bits     |
| Stop-bit    | 1          |
| Parity      | None       |

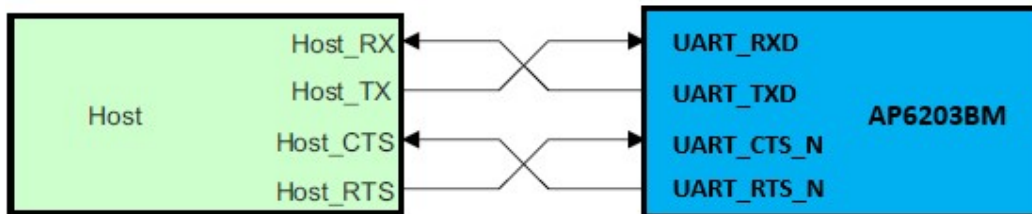

### UART Timing

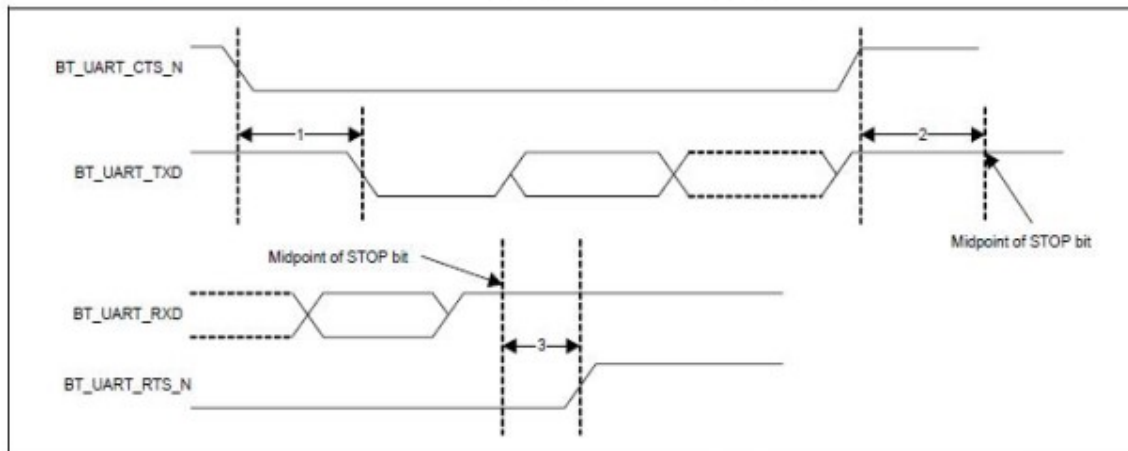

### UART Timing Specifications

| Ref | Characteristics  | Min. | Typ. | Max. | Unit        |
|-----|--|------|------|------|-------------|
| 1   | Delay time, BT_UART_CTS_N low to BT_UART_TXD valid         | -    | -    | 1.5  | Bit periods |
| 2   | Setup time, BT_UART_CTS_N high before midpoint of stop bit | -    | -    | 0.5  | Bit periods |
| 3   | Delay time, midpoint of stop bit to BT_UART_RTS_N high     | -    | -    | 0.5  | Bit periods |

The PCM bus is for audio data.

The PCM Interface on the AP6203BM can connect to linear PCM Codec devices in master or slave mode. In master mode, the AP6203BM generates the PCM\_CLK and PCM\_SYNC signals, and in slave mode, these signals are provided by another master on the PCM interface and are inputs to the AP6203BM.

The configuration of the PCM interface may be adjusted by the host through the use of vendor-specific HCI commands.

SDIO interface is for WLAN function.

BTWDB module supports SDIO V3.0 for all 1.8V 4-bit UHSI speeds:

DS: Default speed up to 25MHz, including 1- and 4-bit modes

HS: High speed up to 50MHz

SDR12: SDR up to 25MHz

SDR25: SDR up to 50MHz

SDR50: SDR up to 80MHz

DDR50: DDR up to 40MHz

The SDIO interface also has the ability to map the interrupt signal onto a GPIO pin for applications requiring a different interrupt than the one provided by the SDIO interface. The ability to force control of the gated clocks from within the device is also provided.

The following three functions are supported:

- Function 0 Standard SDIO function (Max Block Size / Byte Count = 32B)
- Function 1 Backplane Function to access the internal System On Chip (SOC) address space (Max Block Size / Byte Count = 512B)
- Function 2 WLAN Function for efficient WLAN packet transfer through DMA (Max Block Size/Byte Count=512B)
- Function 3 based on the SDIO Type-A Specification for Bluetooth (max. BlockSize/ByteCount = 256/256B)

#### SDIO Pin Description

| SDIO 4-Bit Mode |                          |
|-----------------|--------------------------|
| DATA0           | Data Line 0              |
| DATA1           | Data Line 1 or Interrupt |
| DATA2           | Data Line 2 or Read Wait |
| DATA3           | Data Line 3              |
| CLK             | Clock                    |
| CMD             | Command Line             |

Check the AP6203BM datasheet for more information.

The module has signals that allow the host to control power consumption by enabling or disabling

the Bluetooth, WLAN and internal regulator blocks. These signals are described below. Additionally, diagrams are provided to indicate proper sequencing of the signals for various operating states. The timing value indicated are minimum required values: longer delays are also acceptable.

**WL\_REG\_ON:** Used by the PMU to power up or power down the internal regulators used by the WLAN section. When this pin is high, the regulators are enabled and the WLAN section is out of reset. When this pin is low the WLAN section is in reset

**BT\_REG\_ON:** Used by the PMU to power up or power down the internal regulators used by the BT section. Low asserting reset for Bluetooth. This pin has no effect on WLAN and does not control any PMU functions. This pin must be driven high or low (not left floating)

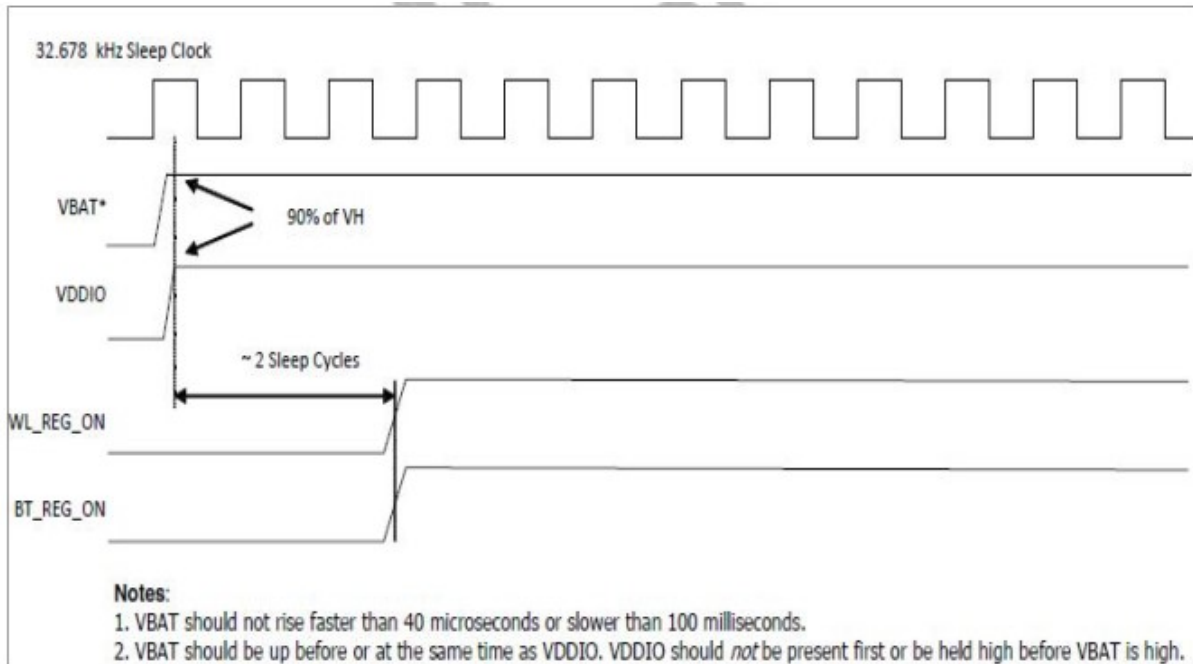

**WLAN=ON, Bluetooth=ON**

## 1.4 Terminology / Abbreviations

BTWDB: BlueTooth WLAN Daughter Board

BT: BlueTooth

## 1.5 Related Documents

| Document          |                                      | Reference number |
|-------------------|--------------------------------------|------------------|
| Alcatel documents |                                      |                  |
| [1]               | PLEIADES HLA for the new range .docx | OD-401314        |
| [2]               |                                      |                  |

| External documents |                                      |
|--------------------|--------------------------------------|
| [3]                | AP6203BM datasheet_V1.2_20220107.pdf |
| [4]                |                                      |

## 1.6 Features

The board must provide the following features:

WLAN:

- IEEE 802.11a/b/g/n dual-band radio with virtual-simultaneous single-band operation.
- Single spatial stream up to a 72 Mbps data rate.
- Supports 1 antenna with one for WLAN & Bluetooth shared port
- Supports standard SDIO v2.0 and SDIO v3.0(SDR50 at 80 MHz and DDR50 at 40 MHz).

Bluetooth:

- Give dual mode BT connectivity (Classic & Low Energy)
- Supports Bluetooth V5.2 with integrated PA for Class 1.5 and Low Energy (BLE).
- Supports extended synchronous connections (eSCO), for enhanced voice quality by allowing for retransmission of dropped packets
- ECI — enhanced coexistence support, ability to coordinate BT SCO transmissions around WLAN receives.
- Interface to the motherboard with UART and PCM, UART up to 4Mbps.
- Integrate PCB antenna, which will be shared Bluetooth and WLAN

## 2 General Requirements

### 2.1 Standards

#### 2.1.1 BT related certification

On the Bluetooth.org website, the existing certifications of BT solutions are listed.

The certification strategy will be as follows:

- Make a certification for the board, with embedded low part of the BT stack, and antenna
- Make BTWDB a module certification, where we can take benefit of the module certification



Requested certifications:

| Generic Certification of BT&WLAN Module |                                   | Standards  |
|---|-----------------------------------|--|
| Radio/Modular approval                  | Europe                            | ETSI EN 300 328 V2.2.2 (2019-07) - ( 2,4 GHz ISM band )  |
|   |                                   | ETSI EN 301 893 V2.1.1 ( 5 GHz RLAN )  |
|   |                                   | ETSI EN 300 440 V2.2.1 ( 5.725-5.875 GHz RLAN )  |
|   | FCC                               | FCC 47 CFR Part 15 Subpart C ( 2,4 GHz ISM band )  |
|   |                                   | FCC 47 CFR Part 15 Subpart E ( 5 GHz RLAN )  |
|   |                                   | FCC grant of equipment authorization / FCC Identifier ( TCB Service )                                |
|   | Canada                            | RSS-Gen issue 5 + RSS-247 issue 2  |
|   |                                   | IC Registration - Record in Radio Equipment List ( REL )   |
|   | Australia/NZ                      | AS/NZS 4268:2017   |
|   | Bluetooth qualification           | test report : Bluetooth ( Classic and low energy ) version 5.2<br>Profiles supported : To be defined |
|   |                                   | product listed at Bluetooth SIG <b>under ALE International company</b>                               |
|   | Wi-Fi compliance                  | Connectivity a/b/g/n<br>Security WPA2/WPA3 (TBC )<br>WMM - Wi-fi Multimedia (TBC )                   |
|   | Japan Radio module certification  | GITEKI   |
|   | China Radio module certification  | CMIIT  |
|   | Brazil Radio module certification | Anatel   |
| Korea Radio module certification        | KCC                               |  |
| Mexico Radio module certification       | IFETEL                            |  |
| Taiwan Radio module certification       | NCC                               |  |
| Human exposure for                      | US                                | FCC 47CFR 2.1091 ( at least 20 cm between transmitter and the body )                                 |

|                                |                                      |  |
|--------------------------------|--------------------------------------|--|
| <b>Bluetooth</b>               |                                      | Refer to FCC KDB Publication 447498 D01 : SAR test exclusion                   |
|                                | <b>EUROPE/AUS/NZ</b>                 | EN 62479:2010  |
|                                | <b>Canada</b>                        | RSS-102 Issue 5  |
|                                | <b>Australia/NZ</b>                  | ARPPANSA : Maximum Exposure Levels to Radiofrequency Fields — 3 kHz to 300 GHz |
| <b>Human exposure for WLAN</b> |                                      | FCC 47CFR 2.1091 ( at least 20 cm between transmitter and the body )           |
|                                | <b>US</b>                            | Refer to FCC KDB Publication 447498 D01  |
|                                | <b>EUROPE/AUS/NZ</b>                 | EN 62311:2008  |
|                                | <b>Canada</b>                        | RSS-102 Issue 5  |
|                                | <b>Australia/NZ</b>                  | ARPPANSA : Maximum Exposure Levels to Radiofrequency Fields — 3 kHz to 300 GHz |
| <b>ECO-DESIGN</b>              | <b>Persistent Organic Pollutants</b> | European Regulation : N° 2019/1021   |
|                                | <b>EU ROHS</b>                       | EU Directive 2011/65/EU including Commission delegated directive 2015/863      |
|                                | <b>REACH</b>                         | European regulation : N° 1907/2006 - Certificate + list of SVHC                |

This will qualify:

- The hardware, radio parts (included Bluetooth and WLAN)
- The Lower part of the BT stack (below HCI interface) located in the BT chip
- The Upper part of the BT stack, which runs on the Host processor.
- RF exposure

This is why, if we re-use this board, a big part of the certification does not need to be done.

## 2.2 Environmental requirements

These are the same as for the terminal for which this board is intended. The tests are made on the daughter board assembled or mounted in a final product, so they are part of the product qualification.

For details see for example PLEIADES HLA for the new range

## 3 General Description

### 3.1 Bluetooth WLAN daughter board BT stack diagram

Broadcom's Bluetooth Simple API (BSA) is a host software stack solution designed to simplify Bluetooth applications development for a wide range of embedded platforms. Based on a client/server model, the BSA Bluetooth daemon (server) runs the Broadcom Bluetooth stack

(protocols and profiles) and drives the UART/USB HCI-supported Bluetooth module. Client applications connect to the server for Bluetooth services and profiles such as FTP, AG, A2DP, etc.

AP6203BM uses BSA Stack, and communicates with a HCI through the UART interface.

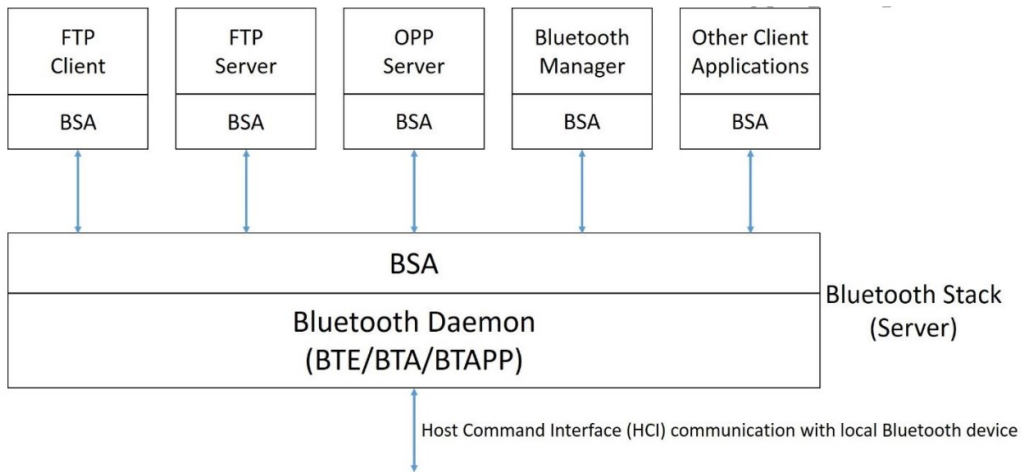

### 3.2 Bluetooth WLAN daughter board bloc diagram

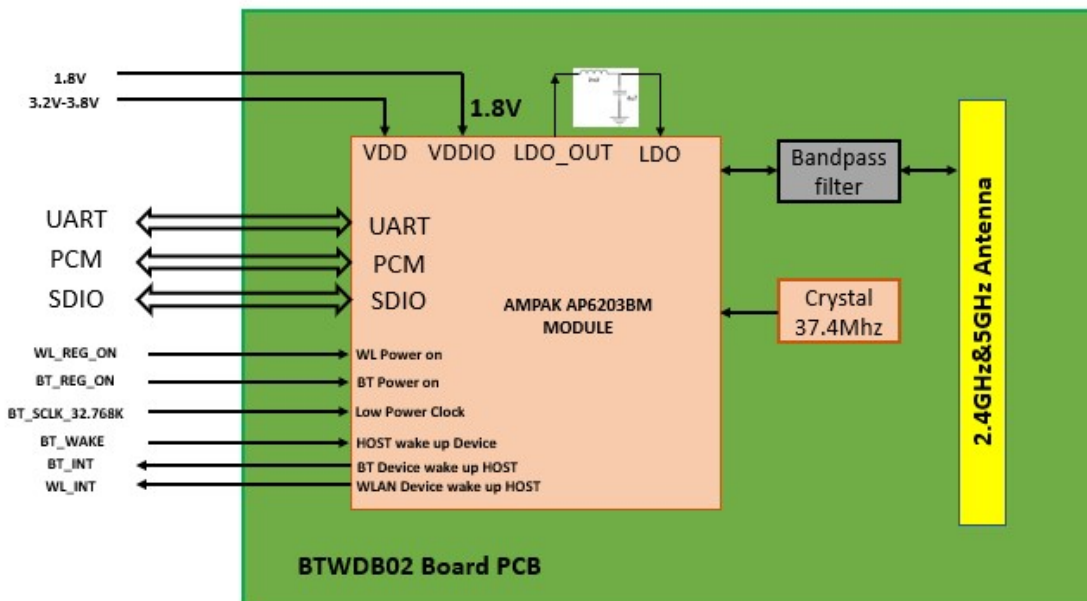

### 3.3 Mechanical aspects

This board will be mounted on other boards. So we can make it with a dongle or directly mounted on board.

For radiofrequency propagation reasons, the antenna area must not cover any copper plane.

For industrial reasons, the board must lay on the CPU board on at least 2/3 of it's surface.

Examples of implementation follow:

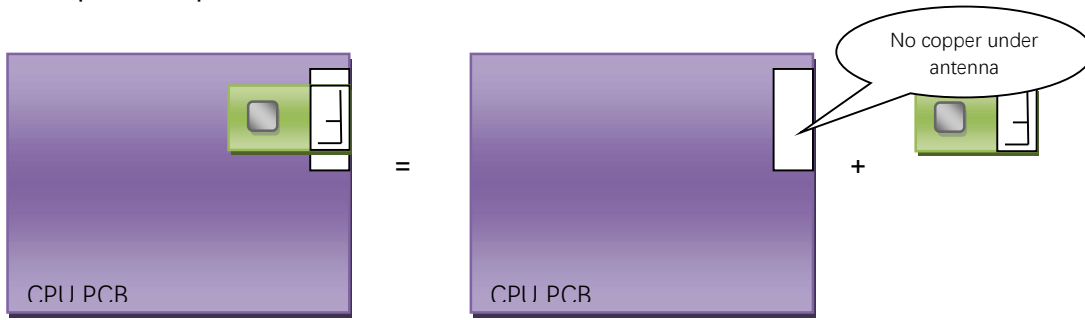

Another alternative, best is:

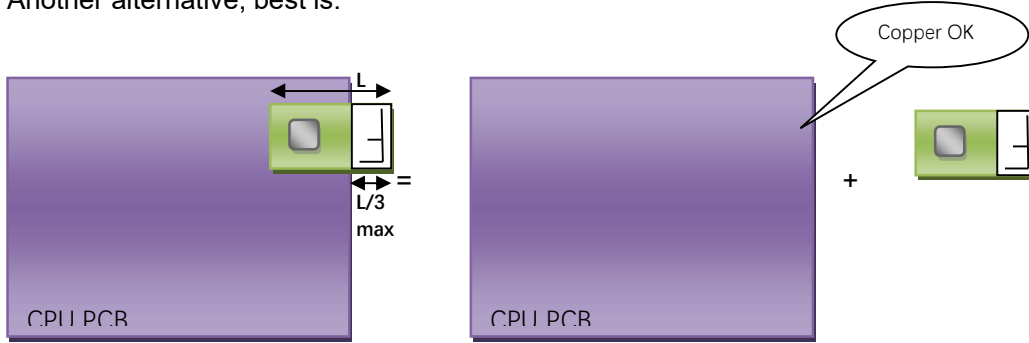

## Connections:

To reduce cost, we want to avoid a board to board connector.

The daughter board will use the technique of the cut metal holes on the board edge (top view):

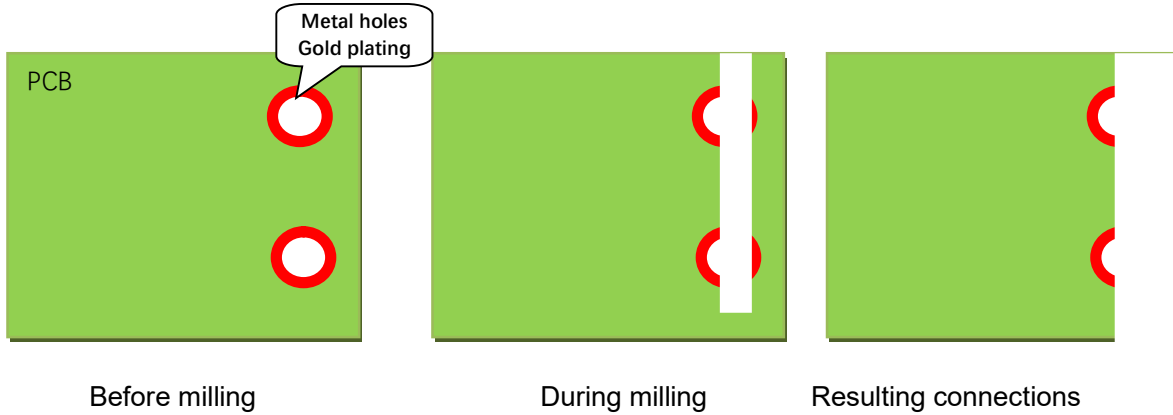

The connections number is 33, spread over three sides of the board as following:

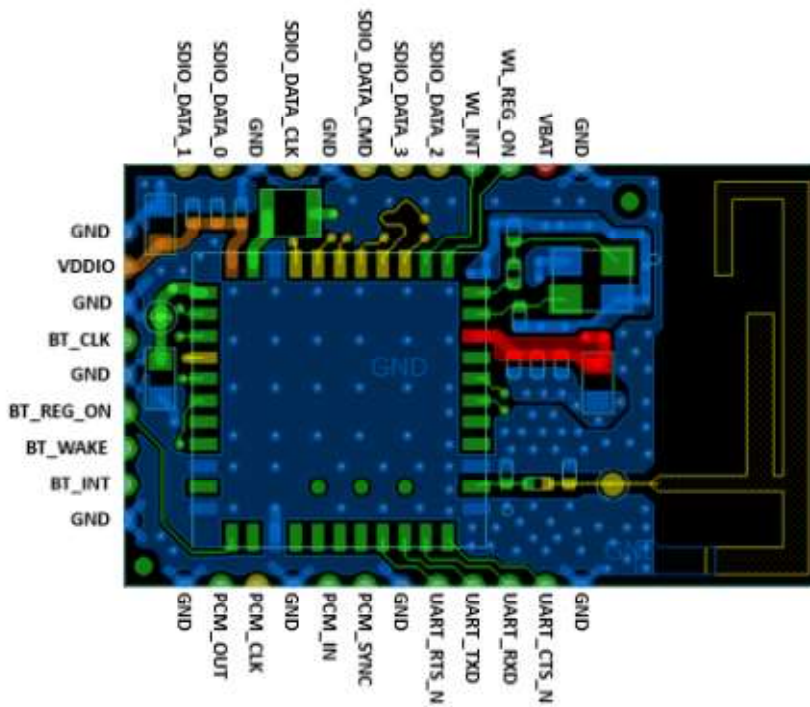

## Mounting on boards

The daughter board is mounted flat directly on the other boards.

This means that:

- There is no component on the bottom side of the BTWDB
  - Also signal vias shall be prohibited to avoid risks of short-circuit with main board GND.

- There is no component on top of the mainboard

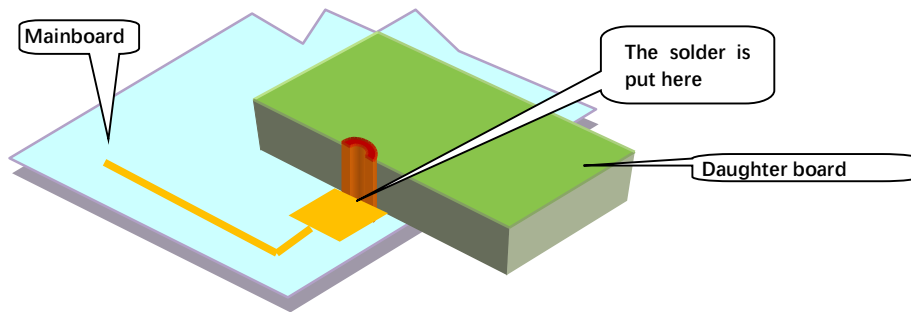

Care must be taken in order to equilibrate the layout, to avoid that the PCB becomes curved during soldering process (due to differential thermal expansion of the copper layers).

The cut-hole size must be defined big enough in order to get a solid solder area, and to avoid that the copper of the hole is snatched during milling process.

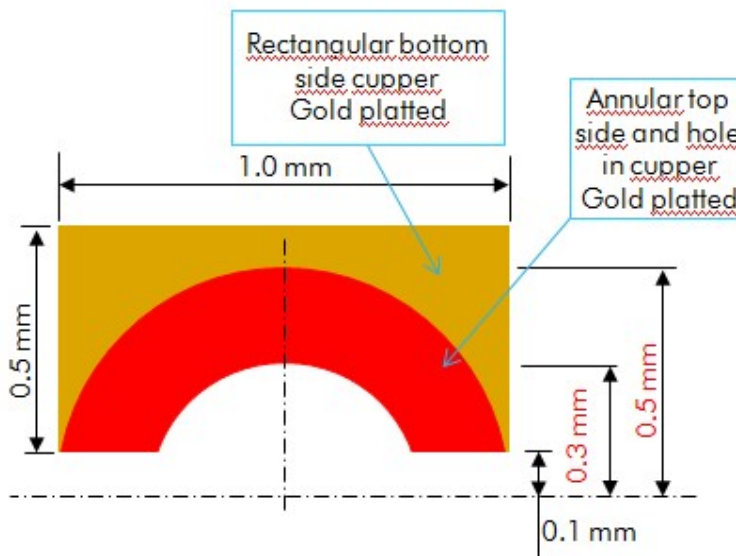

On Main board, the recommended footprint is as follows:

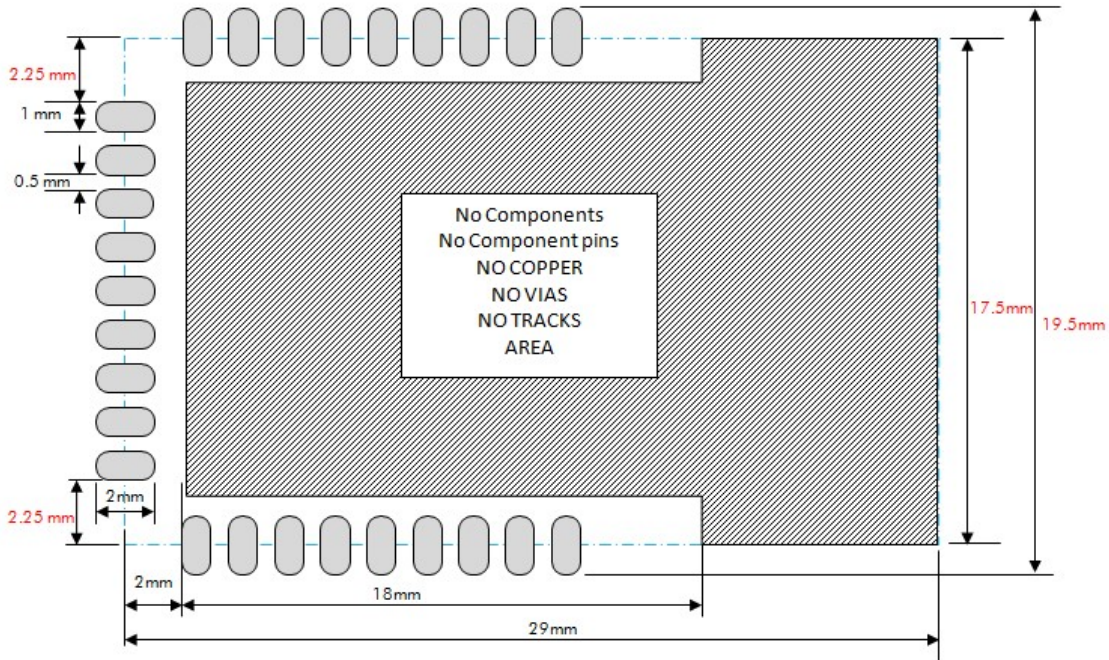

The GND pins must be connected to the GND plane as short as possible, with enough vias. Dotted line is the board outline.

### 3.4 Specification

|                        |  |
|------------------------|--|
| Model Name             | BTWDB02                                      |
| Product Description    | 1Tx/1Rx 802.11 a/b/g/n Wi-Fi + BT 5.2 Module |
| Dimension              | L x W: 29 x 17.5(Typ.)mm、 H : 2.45 (Max.) mm |
| WiFi Interface         | SDIO V3.0                                    |
| BT Interface           | UART / PCM                                   |
| Operating temperature  | -5°C to 45°C                                 |
| V <sub>BAT</sub> type  | 3.3 Volts                                    |
| V <sub>DDIO</sub> type | 1.8 Volts                                    |

Bluetooth specification:

| Feature                      | Description                                |
|------------------------------|--|
| <b>General Specification</b> |  |
| Bluetooth Standard           | BDR(1Mbps)、 EDR(2、3Mbps)、 LE(1Mbps、 2Mbps) |



|                         |  |
|-------------------------|--|
| Host Interface          | UART   |
| Frequency Band          | 2402 MHz ~ 2480 MHz                          |
| Number of Channels      | 79 channels for classic、 40 channels for BLE |
| Modulation              | GFSK, $\pi/4$ -DQPSK, 8DPSK                  |
| <b>RF Specification</b> |  |
|                         | MAX (dBm)                                    |
| BDR Output EIPR Power   | 7  |
| EDR Output EIPR Power   | 7  |
| LE Output EIPR Power    | 7  |

### WLAN RF specification

| Feature  | Description                                  |
|--|--|
| <b>WLAN Standard</b>   | IEEE 802.11b/g/n & Wi-Fi compliant           |
| <b>Frequency Range</b>   | 2.400 GHz ~ 2.4835 GHz (2.4GHz ISM Band)     |
| <b>Number of Channels</b>  | 2.4GHz: Ch1 ~ Ch13                           |
| <b>Modulation</b>  | 802.11b : CCK                                |
|  | 802.11g/n : OFDM /64-QAM、 16-QAM、 QPSK、 BPSK |
| <b>The transmit EVM quality &amp; spectrum mask are compliant with IEEE 802.11 standard</b>                            |  |
| 802.11b  | 18 dBm                                       |
| 802.11g  | 18 dBm                                       |
| 802.11n 20MHz  | 18 dBm                                       |
| Note: The specifications of RF output power are subject to change to fulfill the safety regulation and requirements in |  |

| Feature   | Description   |
|---|---|
| <b>WLAN Standard</b>  | IEEE 802.11a/n & Wi-Fi compliant                            |
| <b>Frequency Range</b>  | 5.15~5.35GHz、 5.47~5.725GHz、 5.725~5.85GHz (5GHz UNII Band) |
| <b>Number of Channels</b>   | 5.18~5.35GHz: Ch36 ~ Ch64                                   |
|   | 5.5~5.72GHz: Ch100 ~ Ch144                                  |
|   | 5.745~5.825GHz: Ch149 ~ Ch165                               |
| <b>Modulation</b>   | 802.11a : OFDM /64-QAM、 16-QAM、 QPSK、 BPSK                  |
|   | 802.11n : OFDM /64-QAM、 16-QAM、 QPSK、 BPSK                  |
| <b>Output Power , tolerance <math>\pm 1.5</math> dB</b>   |   |
| <b>The transmit EVM quality &amp; spectrum mask are compliant with IEEE 802.11 standard</b>   |   |
| 802.11a   | 16.5dbm   |
| 802.11n 20MHz   | 16.5dbm   |
| Note: The specifications of RF output power are subject to change to fulfill the safety regulation and requirements in end-user product |   |

Note: For US and Canada, 2.4GHz WIFI support Ch1~Ch11.

Until further notice, devices subject to this section shall not be capable of transmitting in the band 5600-5650 MHz. This restriction is for the protection of Environment Canada's weather radars operating in this band.



## 4 Detailed Technical Description

### 4.1 Electronic

#### 4.1.1 RF solution to be implemented

The chosen AMPAK AP6203BM Module which is a total solution for a combination of Wi-Fi + BT technologies.

For WI-FI, it supports 802.11a/b/g/n

For Bluetooth, it complies with Bluetooth core specification V5.2

Bluetooth power level is class 2:

BDR output power is 7dBm

EDR output power is 7dBm

LE output power is 7dBm

This module integrates the baseband, the RF amplifier, and power regulator.

It needs externally:

- a bandpass filter + antenna
- an accurate 37.4MHz source (crystal with less than 20ppm initial+ temperature + aging)
- A standard slow clock at 32.768 KHz for low power modes (+/-30ppm), which will be provided by the CPU. This clock MUST stay active continuously, even in SLEEP mode, where it is mandatory to wake up.
- Some passive components.

We implement the reference design from AMPAK Instrument, and with minor adaptation to our needs (test probe headers, some filter capacitor...)

### 4.1.2 Schematic

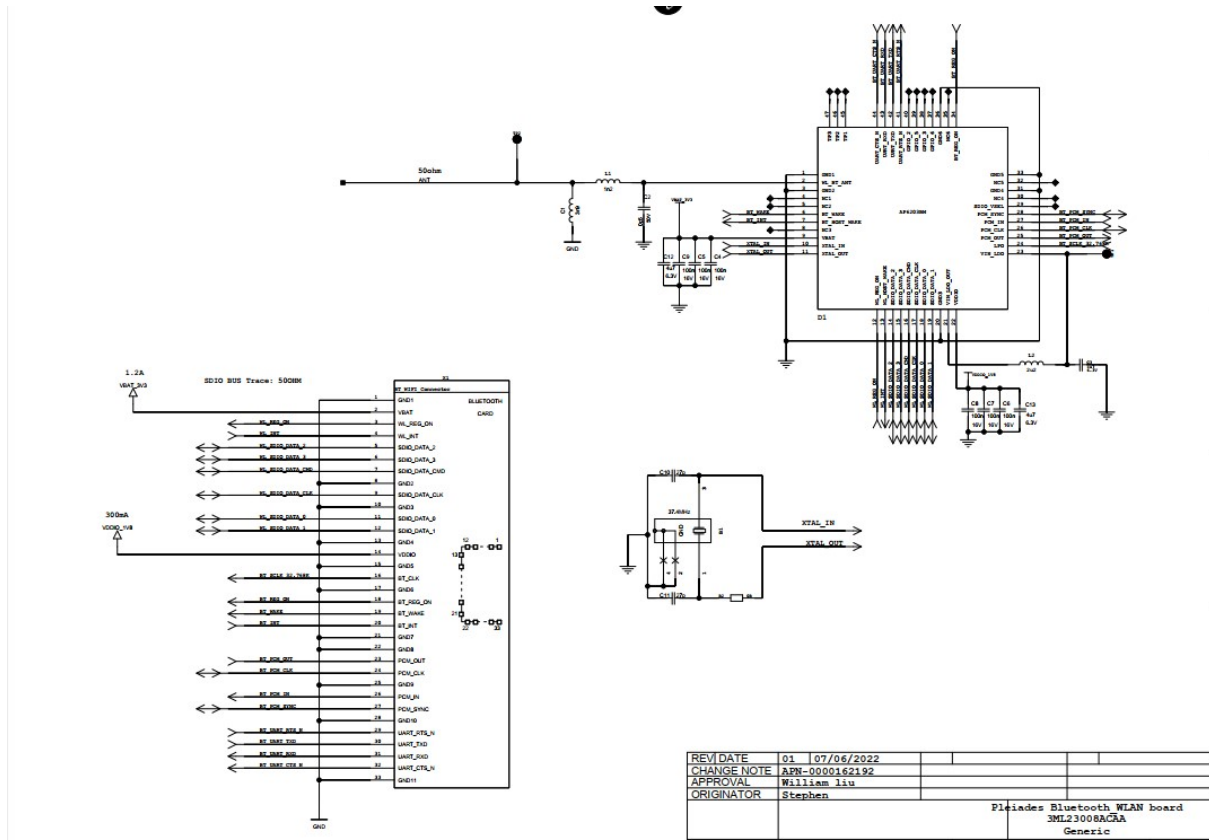

### 4.1.3 BOM

| Name         | Description              | CRN |
|--------------|--------------------------|-----|
| 1AB088200009 | 100nF_10%_16V            | C4  |
| 1AB088200009 | 100nF_10%_16V            | C5  |
| 1AB088200009 | 100nF_10%_16V            | C6  |
| 1AB088200009 | 100nF_10%_16V            | C7  |
| 1AB088200009 | 100nF_10%_16V            | C8  |
| 1AB088200009 | 100nF_10%_16V            | C9  |
| 1AB110820013 | 500fF_+/- .25pF_50V      | C2  |
| 1AB110830003 | 27pF_5%_50V              | C10 |
| 1AB110830003 | 27pF_5%_50V              | C11 |
| 1AB144890041 | 0Ohm_0%                  | R2  |
| 1AB147730004 | 4.7uF_10%_6.3V           | C12 |
| 1AB147730004 | 4.7uF_10%_6.3V           | C13 |
| 1AB147730004 | 4.7uF_10%_6.3V           | C3  |
| 1AB150920003 | 1.2nH_25%_300mA_100MHz/> | L1  |
| 1AB150920009 | 3.9nH_7.69%_300mA_100MH> | C1  |
| 1AB203820007 | BT5.2_WIFI 802.11a/b/g/n | D1  |

|              |                             |     |
|--------------|-----------------------------|-----|
| 1AB226670015 | initial 10ppm_temp 10ppm    | B1  |
| 1AB399060001 | 2.2uH_20%_1.2A              | L2  |
| 3ML22008AAAA | PLEIADES BT_WLAN MODULE PCB | PB1 |

All rights reserved. Passing on and copying of this document, use and communication of its contents not permitted without written authorization from Alcatel

## 4.2 Radio frequency

### 4.2.1 Antenna

We use PCB antenna to compatible with 2.4GHz and 5GHZ. This is a low-cost solution.

We choice the meandered inverted F antenna, which is a variant to have more compacity

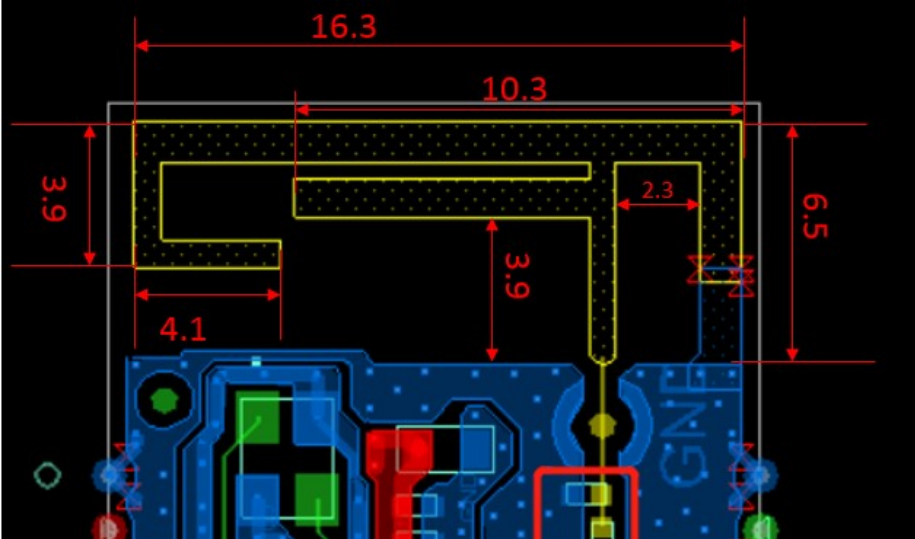

Width of wide Antenna trace: 1.1mm

Width of narrow Antenna trace: 0.7mm

simulation value for designed Antenna pattern efficiency:

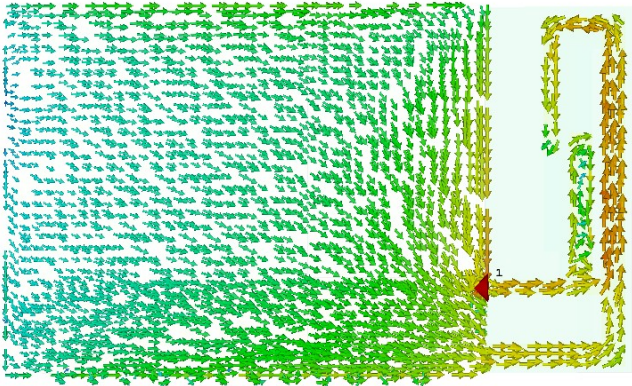

surface current (f=2.5) [1]   
Frequency 2.5 GHz  
Phase 0 °  
Maximum 138.506 A/m

1AA-00014-0004 (9007) A4

All rights reserved. Passing on and copying of this document, use and communication of its contents not permitted without written authorization from Alcatel

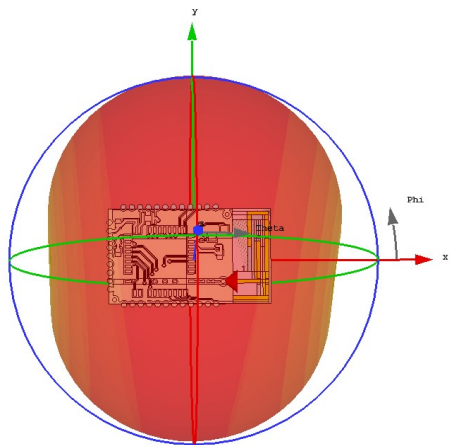

farfield (f=2.5) [1]  
 Type Farfield  
 Approximation enabled (kR >> 1)  
 Component Abs  
 Output Directivity  
 Frequency 2.5 GHz  
 Rad. Effic. -0.8695 dB  
 Tot. Effic. -1.920 dB  
 Dir. 1.948 dBi

5GHz current and radiation diagram simulation:

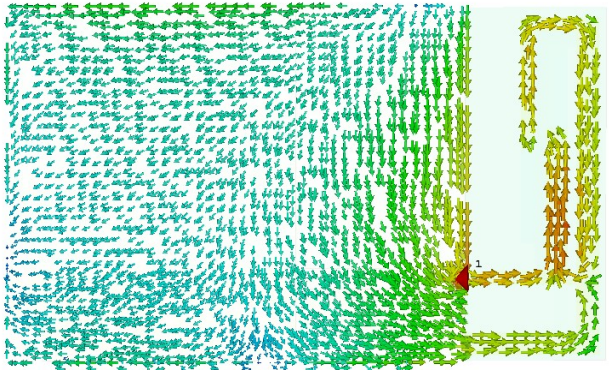

surface current (f=5.5) [1]   
 Frequency 5.5 GHz  
 Phase 0°  
 Maximum 137.03 A/m

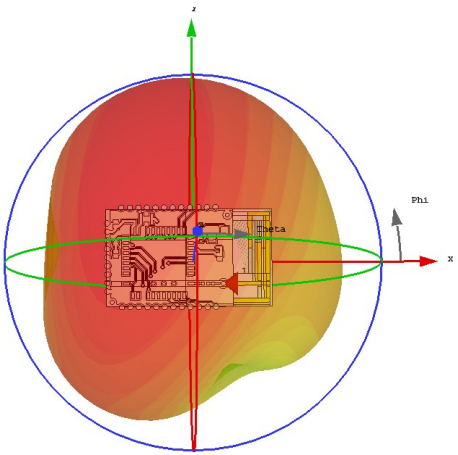

farfield (f=5.5) [1]  
 Type Farfield  
 Approximation enabled (kR >> 1)  
 Component Abs  
 Output Directivity  
 Frequency 5.5 GHz  
 Rad. Effic. -0.7333 dB  
 Tot. Effic. -0.9237 dB  
 Dir. 3.518 dBi

S11 diagram simulation:

All rights reserved. Passing on and copying of this document, use and communication of its contents not permitted without written authorization from Alcatel

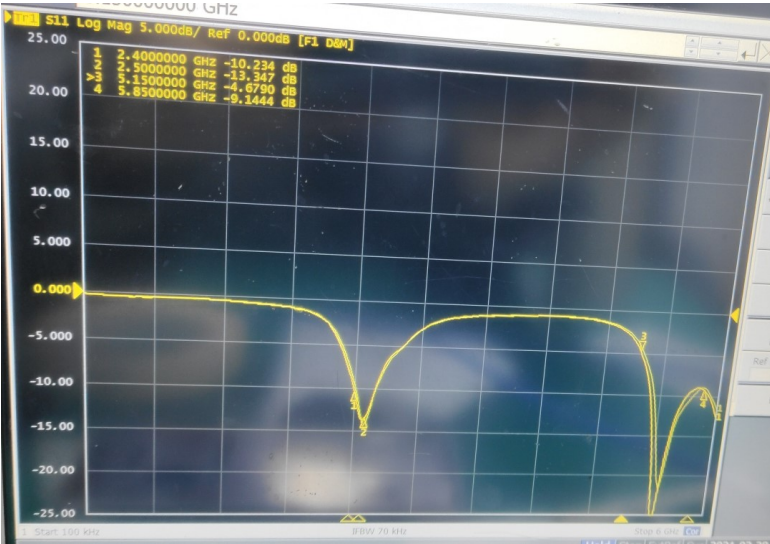

### Real Antenna RF 3D Gain

2405-2800M 3D GAIN

Total

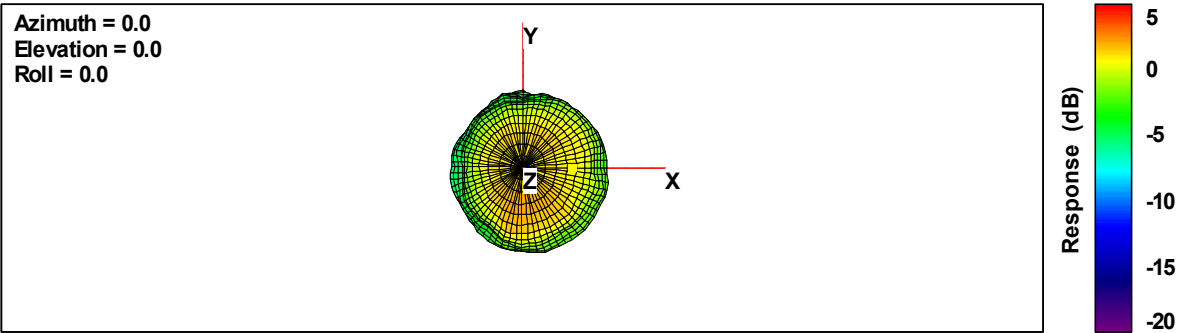

Total

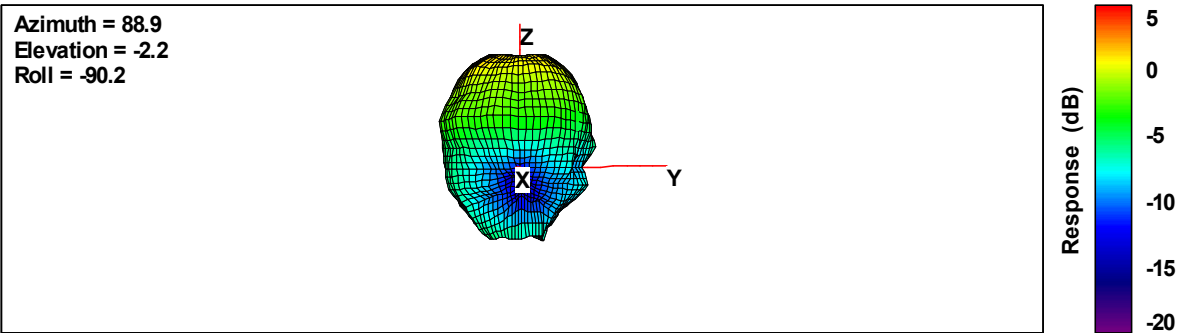

1AA-00014 0004 (9007) A4

All rights reserved. Passing on and copying of this document, use and communication of its contents not permitted without written authorization from Alcatel

1AA-00014-0004 (9007) A4

Total

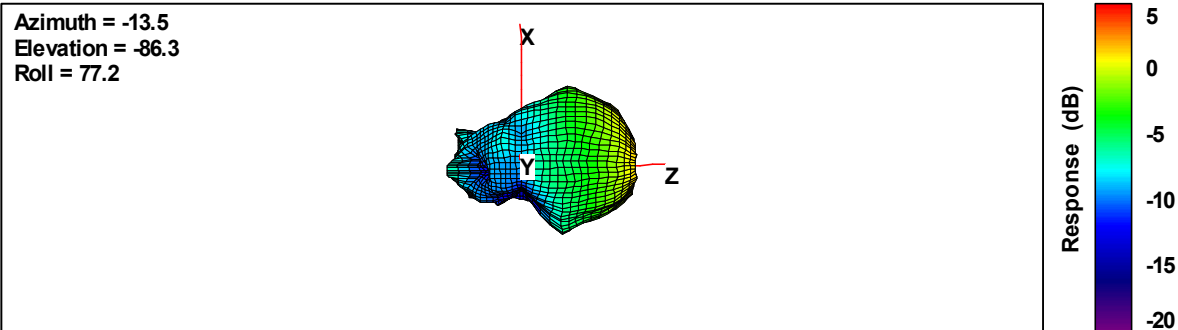

5100-5900M 3D GAIN

Total

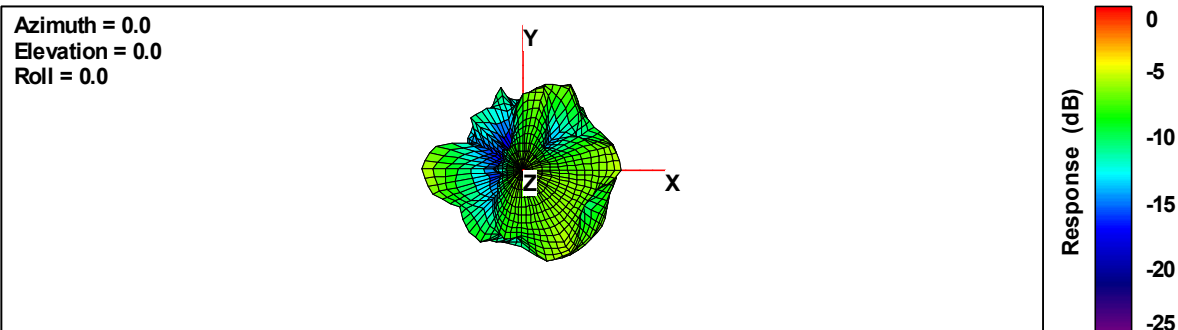

Total

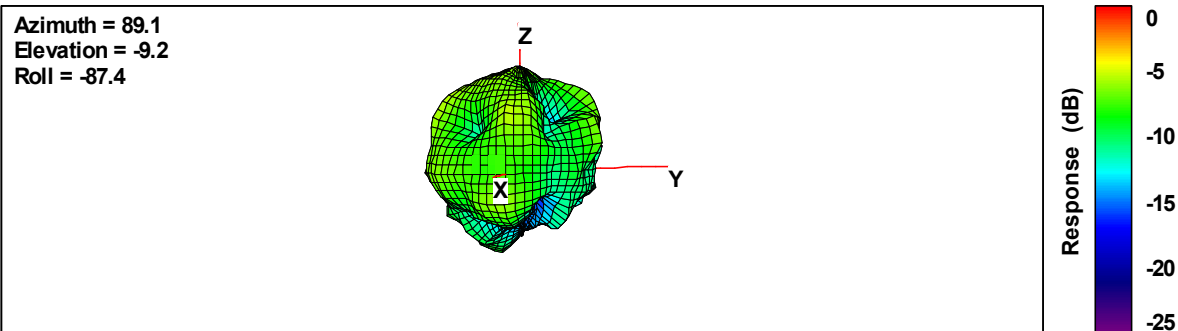

Total

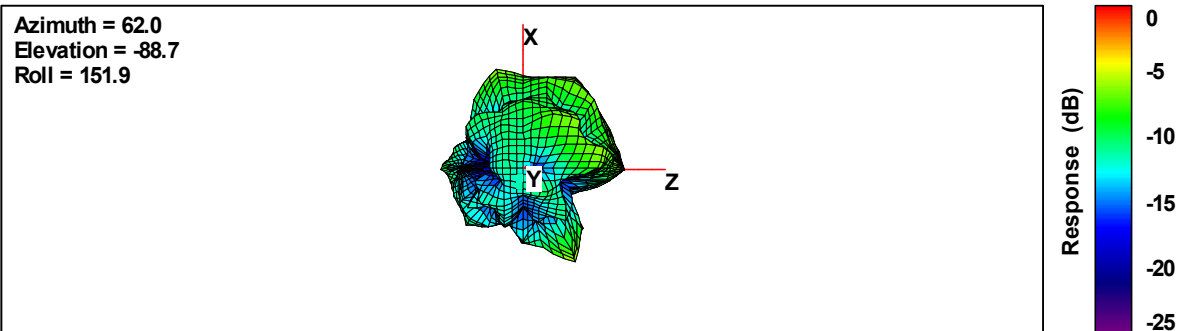

For real RF PCB antenna:

Max 2.4GHz antenna gain is: 3.16dbi

Max 5GHz antenna gain is: 3.00dbi

#### 4.2.2 Immunity to external spurious and interferences

The RF radio can be perturbed by external high amplitude radiofrequency fields. In this case, the RF may show high bit error rate for example.

To improve the immunity, we choice AMPAK AP6203BM chip, there is a shield to cover on RF chip and related RF circuit.

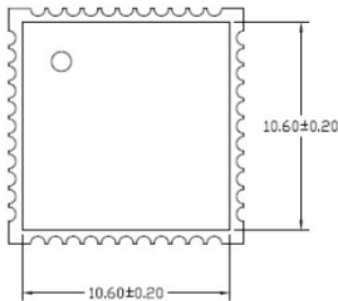

The shield dimension is 10.60x 10.60mm.

### 4.3 Layout

#### 4.3.1 BTWDB layout

The layout recommendations from AMPAK Instruments must be followed.

#### 4.3.2 Place requirements of BTWDB on mainboard

To make the BTWDB on mainboard has similar antenna resonant frequency as BTWDB alone, there are some BTWDB place requirements.

1. The under space of the BTWDB antenna need to be empty.
2. Metal material should be 1cm long away antenna



All rights reserved. Passing on and copying of this document, use and communication of its contents not permitted without written authorization from Alcatel



Mainboard Antenna area should be empty

### 4.4 RF Module label: L-Label

#### 4.4.1 L-Label characteristics

- Dimensions: (10x10) mm
- Label location: On TOP side of the module DB shell
- AL-E part-number: 3ML21086AAAA

#### 4.4.2 L-Label location

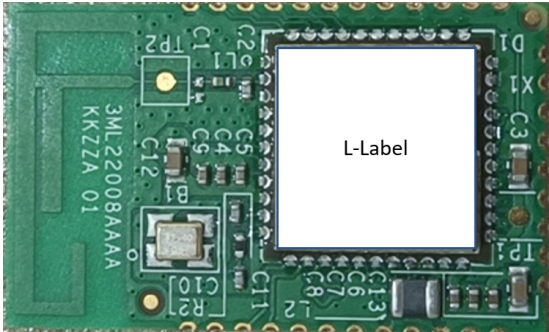

Shield size:10.6mm\*10.6mm

Module dimension: L x W: 29 x 17.5(Typ.)mm、 H : 2.45 (Max.) mm



1AA-00014 0004 (9007) A4

#### 4.4.3 L-Label content

The information available on this label are:

- Product information: G2
- Manufacturing information: G5, G7, G13

The details for each kind of information is provided in the example of label hereafter.

#### L-Label content:

(yellow bullets (x) are contextual and need to be updated with product information's)

All rights reserved. Passing on and copying of this document, use and communication of its contents not permitted without written authorization from Alcatel

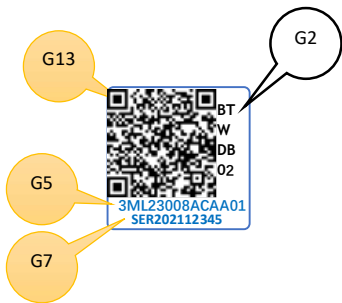

3ML23008ACAA01  
SER202112345  
BD:AABBCCDDEEFF  
WLAN:AABBCCDDEEFF  
FCC ID: OL3BTWDB02  
IC: 1737D-BTWDB02



QR code contains:

For example:



QR code contains:



3ML23008ACAA01;SER202112345;BD:AABBCCDDEEFF;WLAN:AABBCCDDEEFF;FCC ID: OL3BTWDB02;IC: 1737D-BTWDB02

IC number information is inserted inside the QR code. If want to check IC number, you can scan the QR code to get the information.

FCC ID: OL3BTWDB02  
IC: 1737D-BTWDB02

### FCC Statement

This device complies with Part 15 of the FCC Rules. Operation is subject to the following two conditions: (1) This device may not cause harmful interference, and (2) this device must accept any interference received, including interference that may cause undesired operation.

NOTE: This equipment has been tested and found to comply with the limits for a Class B digital device, pursuant to Part 15 of the FCC Rules. These limits are designed to provide reasonable protection against harmful interference in a residential installation. This equipment generates uses and can radiate radio frequency energy and, if not installed and used in accordance with the instructions, may cause harmful interference to radio communications. However, there is no guarantee that interference will not occur in a particular installation. If this equipment does cause harmful interference to radio or television reception, which can be determined by turning the equipment off and on, the user is encouraged to try to correct the interference by

one of the following measures:

- Reorient or relocate the receiving antenna.
- Increase the separation between the equipment and receiver.
- Connect the equipment into an outlet on a circuit different from that to which the receiver is connected.
- Consult the dealer or an experienced radio/TV technician for help.

WARNING: Any changes or modifications not expressly approved by the party responsible for compliance could void the user's authority to operate this equipment.

The device must not be co-located or operating in conjunction with any other antenna or transmitter.

### CAUTION

To reduce potential radio interference to other users, the antenna type and its gain should be so chosen that the equivalent isotropically radiated power (e.i.r.p.) is not more than that permitted for successful communication.

(i) the device for operation in the band 5,150 – 5,250 MHz is only for indoor use to reduce the potential for harmful interference to co-channel mobile satellite systems.

(ii) high-power radars are allocated as primary users (i.e. priority users) of the bands 5,250 – 5,350 MHz and 5,650 – 5,850 MHz and that these radars could cause interference and/or damage to LE-LAN devices.

### IC Statement

This device complies with RSS247 of Industry Canada. Cet appareil se conforme à RSS247 de Canada d'Industrie. This device complies with Industry Canada license-exempt RSS standard(s). Operation is subject to the following two conditions: (1) this device may not cause interference, and (2) this device must accept any interference, including interference that may cause undesired operation of the device. appareils radio exempts de licence. Son fonctionnement est sujet aux deux conditions suivantes: (1) le dispositif ne doit pas produire de brouillage préjudiciable, et (2) ce dispositif doit accepter tout brouillage reçu, y compris un brouillage susceptible de provoquer un fonctionnement indésirable.

### RF exposure information:

This device complies with FCC and IC radiation exposure limits set forth for an uncontrolled environment.

Cet appareil est conforme aux limites d'exposition aux rayonnements de la FCC et de l'IC établies pour un incontrôlé environnement.

The device should be installed and operated with a minimum distance of 30cm between the radiator and your body.

L'appareil doit être installé et utilisé avec une distance minimale de 30 cm entre le radiateur et votre corps.

### Module Statement

The **BTWDB01** module has received Federal Communications Commission (FCC) CFR47 Telecommunications, Part 15 Subpart C & E "Intentional Radiators" single-modular approval in accordance with Part15.212 Modular Transmitter approval. It's also has been certified for use in Canada under Innovation, Science and Economic Development Canada (ISED, formerly Industry Canada) Radio Standards Procedure

(RSP) RSP-100, Radio Standards Specification (RSS) RSS-Gen and RSS-247. Single-modular transmitter approval is defined as a complete RF transmission sub-assembly, designed to be incorporated into another device, that must demonstrate compliance with FCC & IC rules and policies independent of any host. A transmitter with a modular grant can be installed in different end-use products (referred to as a host, host product, or host device) by the grantee or other equipment manufacturer, then the host product may not require additional testing or equipment authorization for the transmitter function provided by that specific module or limited module device.

The user must comply with all of the instructions provided by the Grantee, which indicate installation and/or operating conditions necessary for compliance.

The host product itself is required to comply with all other applicable FCC & IC equipment authorizations regulations, requirements and equipment functions that are not associated with the transmitter module portion. For example, compliance must be demonstrated: to regulations for other transmitter components within a host product; to requirements for unintentional radiators (Part 15 Subpart B & ICES-003), such as digital devices, computer peripherals, radio receivers, etc.; and to additional authorization requirements for the non-transmitter functions on the transmitter module (i.e., Suppliers Declaration of Conformity (SDoC) or certification) as appropriate (for example, Bluetooth and Wi-Fi transmitter modules may also contain digital logic functions).

### **LABELING AND USER INFORMATION REQUIREMENTS**

The **BTWDB02** module has been labeled with its own FCC ID & IC number.

FCC ID: OL3BTWDB02, IC: 1737D-BTWDB02

**END OF DOCUMENT**