



MAGNAVOX

**STEREO SUITCASE
TURNTABLE SYSTEM**

**with RGB Changing Lights
and Bluetooth® Wireless Technology**

Owner's Manual

PLEASE READ BEFORE OPERATING THIS EQUIPMENT.

Model: MD699

IMPORTANT SAFETY INSTRUCTIONS

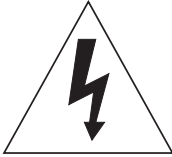

CAUTION

**RISK OF ELECTRIC SHOCK
DO NOT OPEN**



CAUTION: TO REDUCE THE RISK OF ELECTRIC SHOCK, DO NOT REMOVE COVER (OR BACK). NO USER-SERVICEABLE PARTS INSIDE. REFER SERVICING TO QUALIFIED SERVICE PERSONNEL.



The lightning flash with arrowhead symbol within an equilateral triangle is intended to alert the user to the presence of uninsulated dangerous voltage within the product's enclosure that may be of sufficient magnitude to constitute a risk of electric shock to persons.



The exclamation point within an equilateral triangle is intended to alert the user to the presence of important operating and maintenance(servicing) instructions in the literature accompanying the appliance.

WARNING:

TO REDUCE THE RISK OF FIRE OR ELECTRIC SHOCK, DO NOT EXPOSE THIS PRODUCT TO RAIN OR MOISTURE.

WARNING:

TO REDUCE THE RISK OF FIRE OR ELECTRIC SHOCK, AND ANNOYING INTERFERENCE, USE THE RECOMMENDED ACCESSORIES ONLY.

IMPORTANT SAFETY INSTRUCTIONS

Before using the unit, be sure to read all operating instructions carefully. Please note that these are general precautions and may not pertain to your unit. For example, this unit may not have the capability to be connected to an outdoor antenna.

1) Read these instructions.

All the safety and operating instructions should be read before the product is operated.

2) Keep these instructions.

The safety and operating instructions should be retained for future reference.

3) Heed all warnings.

All warnings on the product and in the operating instructions should be adhered to.

4) Follow all instructions.

All operating and use instructions should be followed.

5) Do not use this apparatus near water.

Do not use this product near water and moisture, for example: near a bathtub, washbowl, kitchen sink or laundry tub; in a wet basement; or near a swimming pool.

6) Clean only with dry cloth.

Unplug this product from the wall outlet before cleaning. Do not use liquid cleaners or aerosol cleaners. Use a dry cloth for cleaning.

7) Do not block any ventilation openings. Install in accordance with the manufacturer's instructions.

Slots and openings in the cabinet and in the back or bottom are provided for ventilation, to ensure reliable operation of the product and to protect it from overheating. These openings must not be blocked or covered. The openings should never be blocked by placing the product on a bed, sofa, rug or other similar surface. This product should never be placed near or over a radiator or heat source. This product should not be placed in a built-in installation such as a bookcase or rack unless proper ventilation is provided or the manufacturer's instructions have been adhered to.

8) Do not install near any heat sources such as radiators, heat registers, stoves, or other apparatus (including amplifiers) that produce heat.

9) Do not defeat the safety purpose of the polarized or grounding-type plug. A polarized plug has two blades with one wider than the other. A grounding type plug has two blades and a third grounding prong. The wide blade or the third prong are provided for your safety. If the provided plug does not fit into your outlet, consult an electrician for replacement of the obsolete outlet.

10) Protect the power cord from being walked on or pinched particularly at plugs, convenience receptacles, and the point where they exit from the apparatus.

11) Only use attachments/accessories specified by the manufacturer.

12) Use only with the cart, stand, tripod, bracket, or table specified by the manufacturer, or sold with the apparatus. When a cart is used, use caution when moving the cart/apparatus combination to avoid injury from tip-over.



An appliance and cart combination should be moved with care. Quick stop, excessive force and uneven surfaces may cause the appliance and cart combination to overturn.

13) Unplug this apparatus during lightning storms or when unused for long periods of time.

To protect your product from a lightning storm, or when it is left unattended and unused for long periods of time, unplug it from the wall outlet and disconnect the antenna or cable system. This will prevent damage to the product due to lightning and power-line surges.

14) Refer all servicing to qualified service personnel. Servicing is required when the apparatus has been damaged in any way, such as power-supply cord or plug is damaged, liquid has been spilled or objects have fallen into the apparatus, the apparatus has been exposed to rain or moisture does not operate normally, or has been dropped.

15) Power source

This product should be operated only from the type of power source indicated on the marking label. If you are not sure of the type of power supply to your home, consult your appliance dealer or local power company. For products intended to operate from battery power, or other source, refer to the operation instructions.

16) Power lines

An outside antenna system should not be located in the vicinity of overhead power lines or other electric light or power circuits, or where it can fall into such power lines or circuits. When installing an outside antenna system, extreme care should be taken to keep from touching such power lines or circuits as contact with them might be fatal.

IMPORTANT SAFETY INSTRUCTIONS

17) Overloading

Do not overload wall outlets and extension cords as this can result in a risk of fire or electric shock.

18) Object and liquid entry

Never push objects of any kind into the product through openings as they may touch dangerous voltage points or short out parts that could result in fire or electric shock. Never spill or spray any type of liquid on the product.

19) Outdoor antenna grounding

If an outside antenna is connected to the product, be sure the antenna system is grounded so as to provide some protection against voltage surges and built up static charges. Section 810 of the National Electric Code ANSI/NFPA 70 provides information with respect to proper grounding of the mast and supporting structure, grounding of the lead-in wire to an antenna discharge product, size of grounding conductors, location of antenna-discharge product, connection to grounding electrodes and requirements for the grounding electrodes.

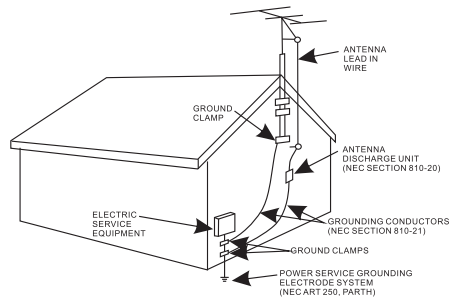

20) Service

Do not attempt to service this product yourself as opening or removing covers may expose you to dangerous voltage or other hazards. Refer all servicing to qualified service personnel.

21) Replacement parts

When replacement parts are required, be sure the service technician uses replacement parts specified by the manufacturer or those that have the same characteristics as the original parts. Unauthorized substitutions may result in fire or electric shock or other hazards.

22) Safety check

Upon completion of any service or repairs to this product, ask the service technician to perform safety checks to determine that the product is in proper operating condition.

23) Damage requiring service

Unplug this product from the wall outlet and refer service to qualified service personnel under the following conditions.

- When the power-supply cord or plug is damaged.
- If liquid has been spilled or objects have fallen into the product.
- If the product has been exposed to rain or water.
- If the product does not operate normally by following the operating instructions. Adjust only those controls that are covered by the operating instructions, as an adjustment of other controls may result in damage and will require extensive work by a qualified technician to restore the product to its normal operation.
- If the product has been dropped or the cabinet has been damaged.
- When the product exhibits a distinct change in performance—this indicates a need for service.

24) Note to CATV system installer

This reminder is provided to call the CATV system installer's attention to Article 820-40 of the NEC that provides guidelines for proper grounding and, in particular, specifies that the cable ground shall be connected to the grounding system of the building, as close to the point of cable entry as practical.

NOTE: Refer all servicing to qualified service personnel. Servicing is required when the unit has been damaged in any way such as the following: the power-supply cord or plug has been damaged, liquid has been spilled into unit, the unit has been exposed to rain or moisture, the unit has been dropped or the unit does not operate normally.

Location of Controls

Top View

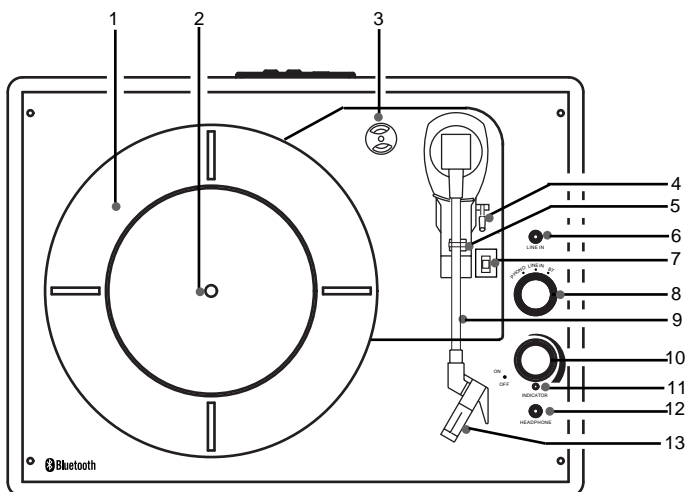

1. Turntable platter
2. Turntable center spindle
3. 45 RPM adapter
4. Lever
5. Tone arm holder
6. LINE IN jack
7. Speed selector
8. Function knob
9. Tone arm
10. Power ON-OFF/
Volume knob
11. Indicators
12. HEADPHONE jack
13. Stylus

Front View

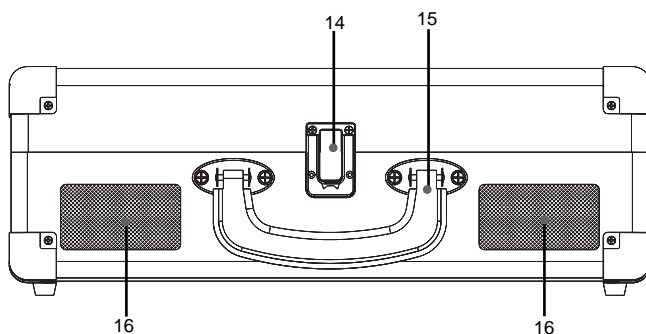

14. Metallic buckle
15. Handle
16. Speakers

Rear View

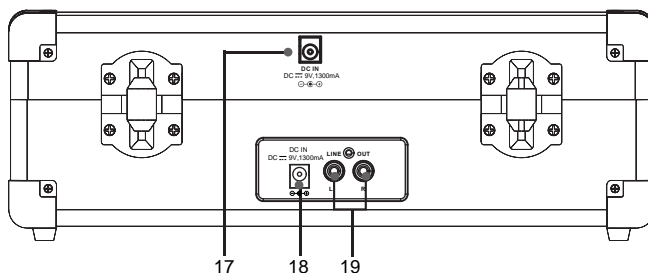

17. DC IN jack for
Decorative LED lights
18. DC IN jack for main unit
19. LINE OUT jacks

Location of Controls

Inner Side View

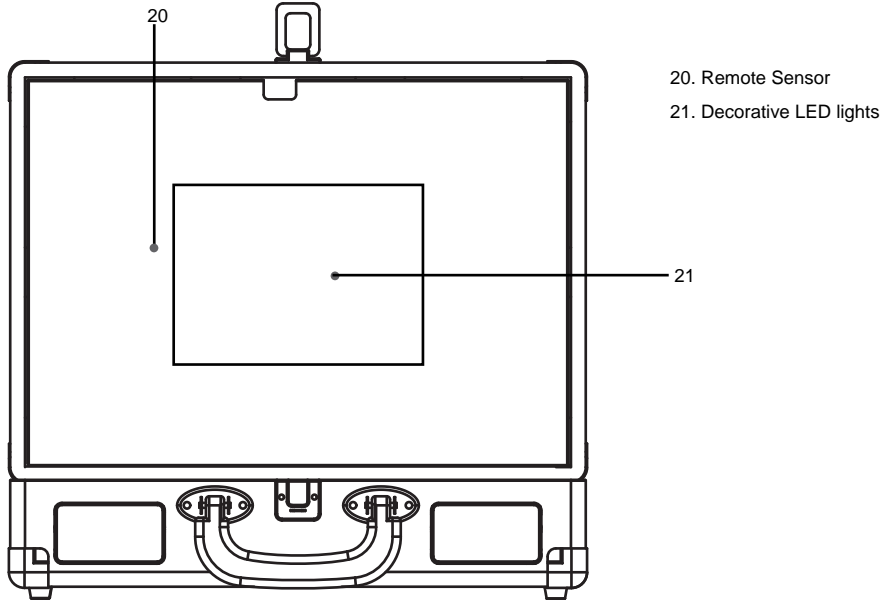

Remote Control:

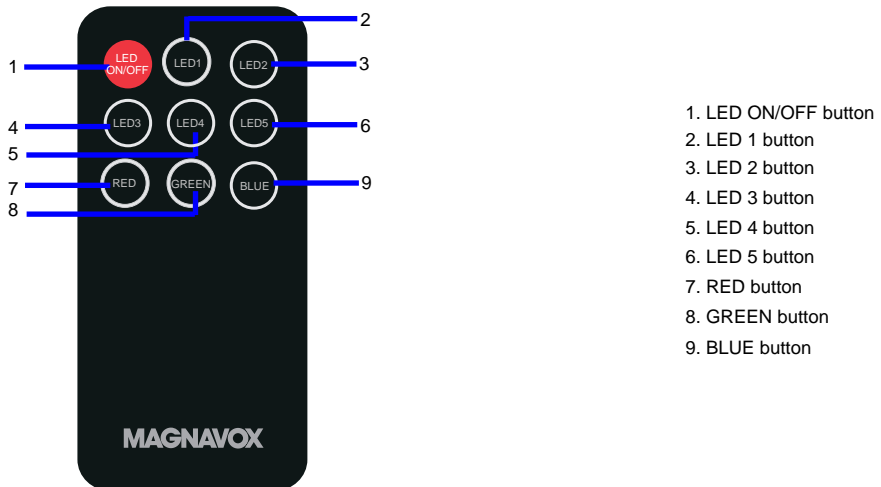

Remote Control

FIRST TIME USE

- Remove and discard the insulation film as figure on the right.
- Replacing the button cell when it is drained:
 1. Push and slide out the battery holder as figure 1 below.
 2. Replace the button cell with a new CR2025 button cell as the polarity markings on the rear of the Remote Control.
 3. Close the battery holder.

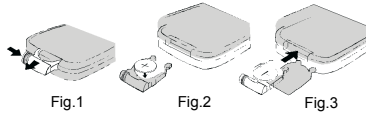
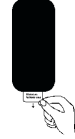

BATTERY PRECAUTIONS

Follow these precautions when using a battery in this device:

1. Use only the size and type of battery specified.
2. Be sure to follow the correct polarity when installing the battery as indicated in the battery compartment, a reserved battery may cause damage to the device.
3. Do not mix different types of batteries together (e.g: Alkaline and Carbon-zinc) or old batteries with fresh ones.
4. If the batteries in the device are consumed or the device is not to be used for a long period of time, remove the batteries to prevent damage or injury from possible leakage.
5. Do not try to recharge the battery not intended to be recharged; it can overheat and rupture. (Follow battery manufacturer's instructions.)
6. The batteries shall not be exposed to excessive heat such as sunshine, fire or the like.
7. Clean the battery contacts and also those of the device prior to battery installation.
8.  This product contains a coin/button cell battery. If the coin/button cell battery is swallowed, it can cause severe internal burn in just 2 hours and can lead to death. Keep new and used batteries away from children. If the battery compartment does not close securely, stop using the product and keep it away from children. If you think batteries might have been swallowed or placed inside any part of the body, seek immediate medical attention.

Remote control operation range

- When there is an obstacle between the remote and the transmitter, the unit may not operate.
- When direct sunlight, an incandescent lamp, fluorescent lamp or any other strong light shines on the REMOTE SENSOR of the unit, the operation of the remote may be unstable.

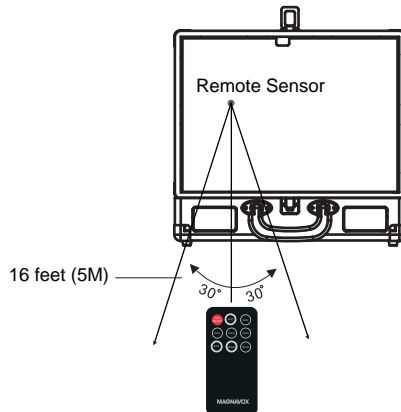

Power Source

1. Connect one of the small plug from the supplied AC/DC Adapter to the DC IN jack of Decorative LED lights; connect the other small plug to the DC IN jack of the Main Unit as illustrated below.
2. Plug the AC/DC Adapter into a conveniently located AC outlet having AC 100-240V~, 50/60Hz.

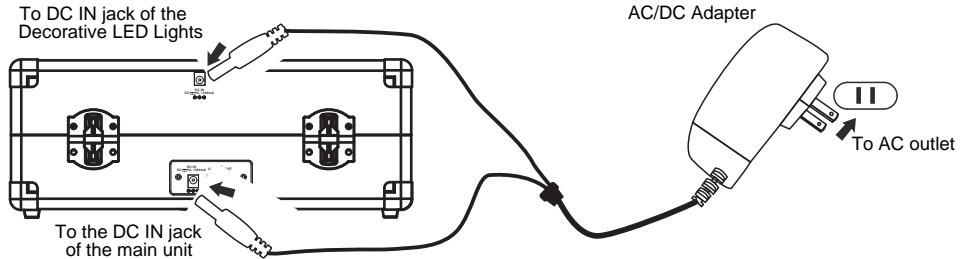

Notes:

- ~ This AC/DC Adapter is intended to be correctly orientated in a vertical or floor mount position.
- ~ For saving energy, if long period of time will not use the unit. Unplug the AC/DC Adapter from wall outlet.

Operation

General Operation:

1. Open the top cover as illustrated below:

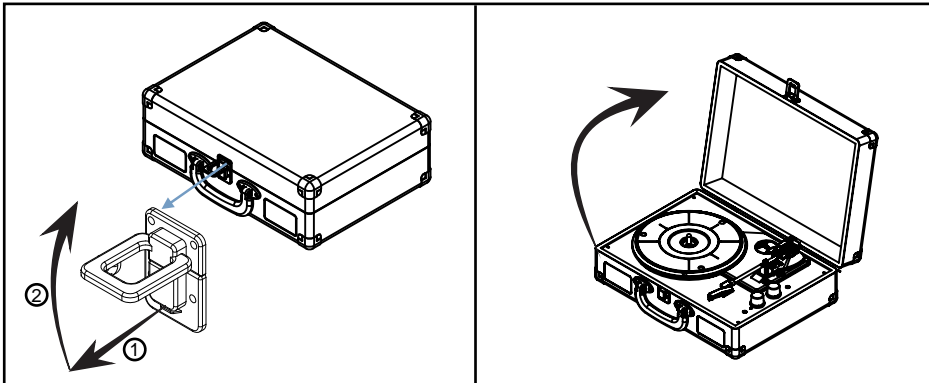

2. Connect the unit to AC power as instructed earlier.
3. Turn the Power ON/OFF--Volume knob clockwise to power on the unit and set the volume to the desired level. The indicator will illuminate, and the LED light panel will light up.
4. Turn the Function selector to the desired position and set to different LED display modes by using the remote control.
5. For Decorative LED Lights:
 - Press the LED ON/OFF button on the remote control repeatedly to turn it ON or OFF.
 - Press the RED; GREEN or BLUE buttons on the remote control to set the color of the lights as desired.
 - Press the LED 1 - LED 5 buttons on the remote control to set or reset the blinking mode of the lights as desired.
6. When finished listening:
 - Turn the Power ON/OFF--Volume knob counterclockwise until "Click" is heard to shut off the unit. The indicators will not light.
 - Press the LED ON/OFF button on the remote control to turn off the Decorative LED Lights.
7. Close the cover then lock it.

Listening through Bluetooth

(BT) Bluetooth Pairing:

For first time use or re-pairing to a new BT Device, pairing it as below:

1. Power on the unit and turn the Function selector to BT position as the instructed earlier. The color of indicator will turn to Blue and blink.
2. Power on the external BT Device and enter to BT searching mode. Start pairing following the on screen instructions from the external BT Device. After paired, the Blue indicator will stop blinking.
(For details pairing procedures, please refer to the user's manual of your BT device.).
3. If pairing is complete you may now play music and answer calls with your external BT Device.
4. During playback, using the controls on the paired BT Device to skip the tracks; pause; play... etc.

Notes:

- When the external BT Device searched the unit, our model number "MD699" will appear on the display of external BT Device.
- If while pairing you are asked for a code please try "0000" or "1234".

Normal operation after paired:

1. Power on the unit and turn the Function selector to the BT position as the instructed earlier. The color of indicator will turn to Blue and blink.
2. Wait a few seconds until the unit auto paired to the external BT Device. (The Blue indicator will stop blinking)
3. If pairing is complete you may now play music and answer calls with your external BT Device.

Listening a Record

1. For first time use, take out the protective cover from the stylus as the illustrated below:

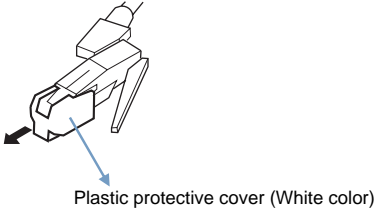

2. Place the Record on the center spindle.

Note: If you are playing a 45 RPM Single (small size record), place the supplied 45 RPM adapter to the center spindle then place the record on it.

3. Slide the Speed selector to 33; 45 or 78 to match the play speed of the record.
4. Unlock the Tone Arm from the holder as the illustrated below:

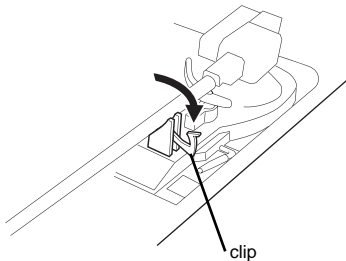

5. Power on the unit and turn the Function selector to the PHONO position as the instructed earlier. The color of indicator will turn to Red.
6. Raise the Lever to raising the Tone Arm then move it to the top of the desired location of the record. Release the Lever to put the Tone Arm onto the record. Plays will auto start.
7. When finished playback, the unit will auto stop turning (or you wants to stop immediately); raise the Lever to rising the Tone Arm then put it back to the Holder. Release the Lever then lock the Tone Arm on the Holder.

Other Connections

LINE IN:

Listen music from the external Audio Player as follows:

1. Connect one end of the supplied Audio Connection Cable to the Phones Jack; Line Out Jack or AUX Out Jack on the external Audio Player.
2. Connect the other end to the LINE IN Jack on the top of unit as the illustrated below:

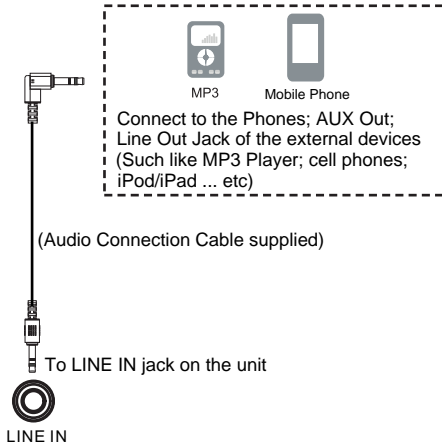

3. Power on the unit and turn the Function selector to the LINE IN position as the instructed earlier. The color of indicator will turn to Purple.
4. Plays the music on the connected external Audio Player as usual.

Note: Make sure the volume level of the external Audio Player was set to high. Otherwise, sound from this unit may weak.

LINE OUT:

To listening from external Audio Amplifier:

1. Connect one end of the RCA Audio Connection Cable (not supplied) to the Line IN Jacks or AUX IN Jacks on the external Audio Amplifier.
2. Connect the other end of the cable to the LINE OUT jacks on the rear of unit as the illustrated below:

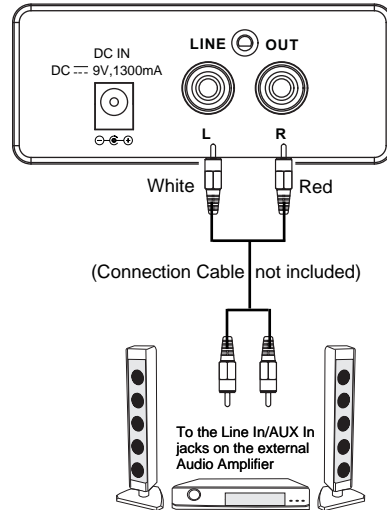

3. Power on the unit and plays music as usual as the instructed earlier.
4. Power on the external Audio Amplifier and set it to LINE IN mode to plays the music from this unit.

HEADPHONE:

For private listening, connect the 3.5mm plug from the Earphone/Headphone (not supplied) into the HEADPHONE jack on the top of unit. Sound from speaker will be auto cut.

Records Handling

- Do not touch the record's grooves. Only handle records, by the edges or the label. Make sure your hands are clean. Skin oils from even clean hands can leave a residue on the record surface that will gradually deteriorate the quality of your record.

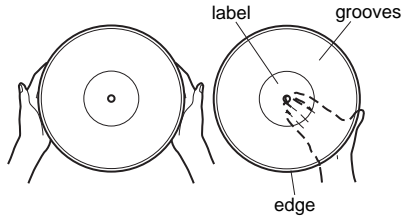

- Keep your hands away from dust. Keep them in a cool, dry place.
- To avoid dust and scratches, keep records in their sleeves and jackets when not in use.
- Store records upright on their edges. Records stored horizontally will eventually bend and warp.
- Do not expose records to direct sunlight or high humidity and temperature. Long exposure to high temperatures will warp the record.
- Do not store your records in the trunk of your car. The temperature in a closed trunk can ruin your collection.
- Store records in an area with a stable temperature and low humidity.
- Should the record become dirty, gently wipe the surface in a circular motion, using a soft anti-static cloth.



Replace the stylus

If the stylus was abraded after long time use, replace it by the supplied extra style as follows:

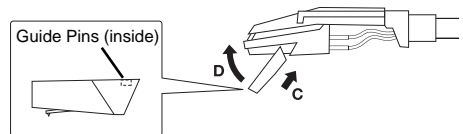
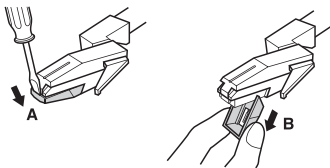

1. Use a screwdriver (not supplied) to push the stylus off then pull it out as the illustrated below:
2. Install the new stylus as illustrated below:





Troubleshooting Guide

Symptom	Possible Cause	Solution
Power		
No power	AC/DC Adaptor had not connected to unit or wall outlet	Connected the AC/DC Adaptor to the unit and wall outlet
	Power ON-OFF/Volume knob is on power off position	Turn the Power ON-OFF/Volume knob clockwise to power on the unit and set the volume to the desired level
Turntable		
Noise or sound distorted	Speed selector wrong setting	Set the Speed selector to the correct position 33, 45 or 78 as the playing speed of record
	The stylus may abrasion after long time used	Replace it by the supplied extra stylus as page 12
BT		
BT not functioning	The BT Device had not paired to the unit	Paired the BT Device to the unit as page 9
Sound weak or distortion	The BT Device too far from the unit	Place the BT Device close to the unit

General Specifications

Power Source:	DC  9V, 1300mA, 
Audio Power:	1.8 W (RMS) x 2
Impedence of Speakers:	4 Ohm; 3W x 2
BT Version:	2.1
BT Effective Range:	32 feet in open area
Turntable:	
Speed:	33; 45; 78 rpm selectable
Type of Stylus:	CSC-015

Accessories

- 1 x User's Manual
- 1 x AC/DC Adaptor (Input: AC 100-240V~; 50/60 Hz; 0.5A; Output: DC  9V, 1300mA, )
- 2 x Stylus (one pre-mounted)
- 1 x 45 RPM Adaptor
- 1 x Audio connect cable with 3.5 mm stereo plugs
- 1 x Remote Control (with CR2025 button cell)

**SPECIFICATIONS AND ACCESSORIES ARE SUBJECT TO CHANGE
WITHOUT NOTICE**

LIMITED WARRANTY

Craig warrants this product to be free from manufacturing defects in material and workmanship under normal use for a period of 90 days from date of purchase. If service is required, please return the product to the store where it was purchased for exchange; or, pack the unit in the original packing material with all accessories if applicable, a copy of your sales receipt and a Cashier's check or Money Order for \$15 (to cover shipping and handling costs) payable to Craig Electronics Inc. For consumers in Canada, please make sure that the cashier check or money order is redeemable through a U.S. bank. Ship your product freight pre-paid. Your unit will be repaired, replaced or if the unit can not be repaired or replaced, a refund will be forwarded to you within four weeks of receipt of your unit. Please ship your unit to:

Craig Electronics Inc.
1160 NW 163 Drive
Miami, FL 33169

This warranty is void if the product has been: a) Used in a commercial application or rental. b) Damaged through misuse, negligence, or abuse. c) Modified or repaired by anyone other than an authorized Craig service center. d) Damaged because it is improperly connected to any other equipment.

Note: This warranty does not cover: a) Ordinary adjustments as outlined in the Owner's Manual which can be performed by the customer. b) Damage to equipment not properly connected to the product. c) Any cost incurred in shipping the product for repair. d) Damage to the product not used in the USA.

This warranty is not transferable and only applies to the original purchase. Any implied warranties, including the warranty of merchantability, are limited in duration to the period of this expressed warranty and no warranty whether expressed or implied shall apply to the product thereafter.

Under no circumstance shall Craig be liable for any loss or consequential damage arising out of the use of this product. This warranty gives specific legal rights. However, you may have other rights which may vary from state to state. Some states do not allow limitations on implied warranties or exclusion of consequential damage. Therefore, these restrictions may not apply to you.

To Obtain Service on your Product
email: service@craigelectronics.com

FCC NOTICE:

This equipment has been tested and found to comply with the limits for a Class B digital device, pursuant to Part 15 of the FCC Rules. These limits are designed to provide reasonable protection against harmful interference in a residential installation. This equipment generates, uses and can radiate radio frequency energy and, if not installed and used in accordance with the instructions, may cause harmful interference to radio communications. However, there is no guarantee that interference will not occur in a particular installation. If this equipment does cause harmful interference to radio or television reception, which can be determined by turning the equipment off and on, the user is encouraged to try to correct the interference by one or more of the following measures:

- Reorient or relocate the receiving antenna.
- Increase the separation between the equipment and receiver.
- Connect the equipment into an outlet on a circuit different from that to which the receiver is connected.
- Consult the dealer or an experienced radio/TV technician for help.

FCC STATEMENT:

This device complies with part 15 of the FCC Rules. Operation is subject to the following two conditions:

- (1) This device may not cause harmful interference, and
- (2) This device must accept any interference received, including interference that may cause undesired operation.

FCC Radiation Exposure Statement:

This equipment complies with FCC radiation exposure limits set forth for an uncontrolled environment .

This transmitter must not be co-located or operating in conjunction with any other antenna or transmitter.

ISED Radiation Exposure Statement:

This equipment complies with ISED RF radiation exposure limits set forth for an uncontrolled environment.

This transmitter must not be co-located or operating in conjunction with any other antenna or transmitter.

FCC WARNING:

To assure continued operation, follow the attached installation instructions and use only shield cables when connecting to other devices. Changes or modifications not expressly approved by the party responsible for compliance could void the user's authority to operate the equipment.