



**CRAIG®**

# **BLUETOOTH® STEREO HEADSET**

## *Owner's Manual*

PLEASE READ BEFORE OPERATING THIS EQUIPMENT.

**Model: CBH508-OD**

Size: 148.5(W) x 210(H)mm (A5)

**FCC INFORMATION:**

Warning: Changes or modifications to this unit not expressly approved by the party responsible for compliance could void the user's authority to operate the equipment.

This equipment has been tested and found to comply with the limits for a Class B digital device, pursuant to part 15 of the FCC Rules. These limits are designed to provide residential protection against harmful interference in a residential installation. This equipment generates, uses and can radiate radio frequency energy and, if not installed and used in accordance with the instructions, may cause harmful interference to radio communications. However, there is no guarantee that interference will not occur in a particular installation. If this equipment does cause harmful interference to radio or television reception, which can be determined by turning the equipment off and on, the user is encouraged to try to correct the interference by one or more of the following measures:

- Reorient or relocate the receiving antenna.
- Increase the separation between the equipment and receiver.
- Connect the equipment into an outlet on the circuit different from that to which the receiver is connected.
- Consult the dealer or an experienced radio/TV technician for help.

The device has been evaluated to meet general RF exposure requirement.

The device can be used in portable exposure condition without restriction.

**FCC NOTICE:**

To assure continued compliance, follow the attached installation instructions and use only shielded cables when connecting to other devices. Modifications not authorized by the manufacturer may void user's authority to operate this device.

## Location of Controls

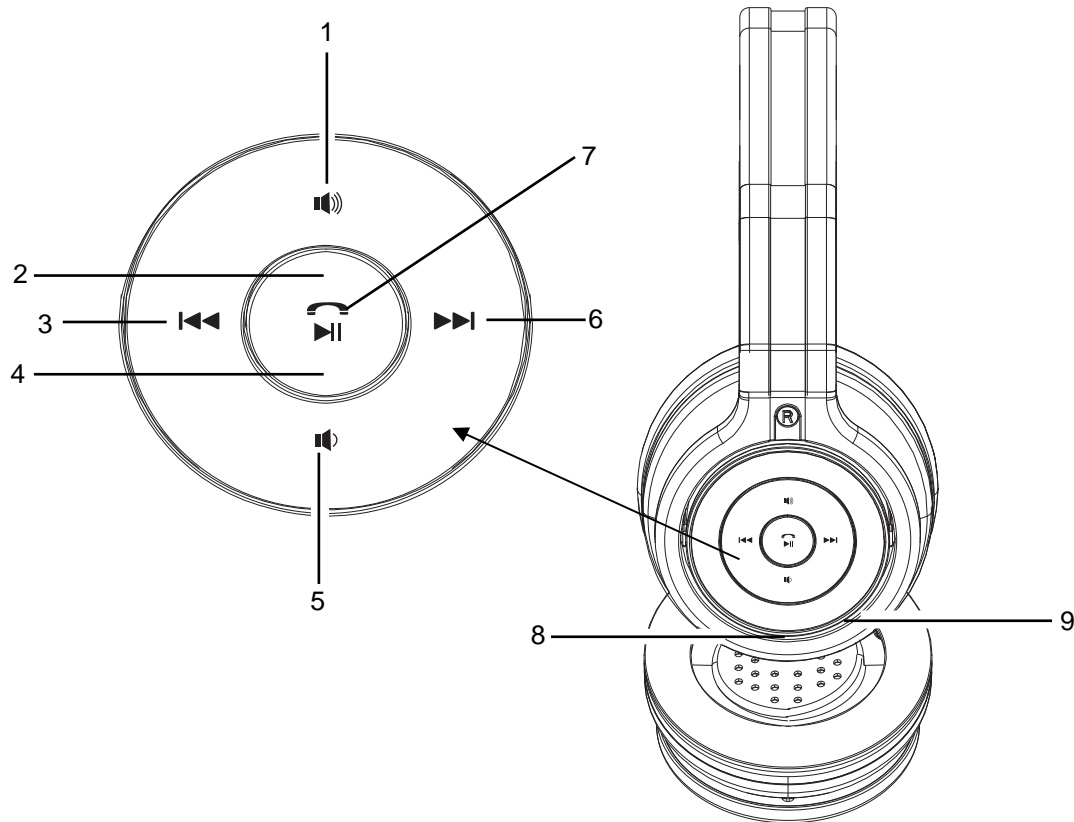

1. Volume Up Button
2. BT Indicator
3. Button
4. Charging Indicator

5. Volume Down Button
6. Button
7. Button
8. Micro USB Port (For Charging Only)
9. Built-in Microphone

## Battery Recharge:

The unit has a built-in Li-ion rechargeable battery, recharge it before use or when the battery is consumed as follow:

1. Insert the small plug from the USB connection cable to the Micro USB Port on the unit.
2. Insert the other plug to the USB Port on the Computer or any USB Charger having DC 5V output.
3. During charging, the Charging Indicator will light. When finished, it will turned off.

**Notes:** Your battery will last longer if you follow these simple guidelines for charging and storing it.

- A. Recharge and store the device within the temperature range of 5°C~35°C (40°F~95°F).
- B. Do not overcharge ( longer than 24 hours ). Excessive charging or discharging may shorten the battery's life.
- C. Battery life naturally shortens slowly over time.
- D. The rechargeable battery incorporated in this product is not replaceable.

## Operation:











In the first time use or re-pairing to a new Bluetooth device, follow these instructions:

1. Press and hold the  Button approx. 1 second to power on the unit. The BT Indicator will illuminate and fast blink.
2. Power on the external BT device and enter to BT searching mode. Start pairing following the on screen instructions on the external BT device. After paired, the blinking frequency of BT Indicator will slow down. ( For details pairing procedures, please refer to the user's manual of your BT device.)



Notes:

- When the external BT device searched the unit, our model number "CBH508-0D" will appear on the display of external BT device.
- Pairing code "0000" or "1234" may need to enter.



## Normal operation after pairing:

1. Turn on the BT function of the external BT device.
2. Press and hold the  Button approx. 1 second to power on the unit. The BT Indicator will illuminate and fast blink. Wait a few seconds until the unit auto paired to the external BT device. (The blinking frequency of BT Indicator will slow down.)
3. Plays the music in the paired BT device as usual.
4. During playback:
  - Press the  /  Button to skip the tracks.
  - Press the  /  Button to adjust volume level.
  - Press the  Button to pause, press again to resume.
5. If the unit is paired to Cell Phone:
  - When a call is incoming during listening, press the  Button to hook off then speak to the built-in microphone to answer the phone. When finished, press the  Button to hook on then resume to music playback.
  - Press the  Button twice to redial the last dialed phone number.
6. When finishing listening , press and hold the  Button approx. 2 seconds to power off the unit.

### Troubleshooting:

Can't be power on	Battery consumed	Recharge the battery.
No sound	Volume was set to minimum level	Press the  to increase volume level.
Sound distortion	Volume too high	Press the  to reduce volume level.

### Specifications:

Power Source:.....Built-in DC  3.7 V; 400 mAH (1.48 WH) rechargeable Li-ion battery, recharge by DC  5V through Micro USB Port

Impedance of Earpiece:.....32 ohm, 25 mW x 2

Audio Power:.....22 mW per channel

BT Version: ..... V2.1+EDR

BT Effective Range:.....32 Feet in open area

Play Time After Fully Charge: ..... Approximate 6 Hours

### Accessories:

- 1 x User's Manual
- 1 x USB Connection Cable ( for charge only )

**SPECIFICATIONS AND ACCESSORIES ARE SUBJECT TO CHANGE WITHOUT NOTICE**

## LIMITED WARRANTY

Craig warrants this product to be free from manufacturing defects in material and workmanship under normal use for a period of 90 days from date of purchase. If service is required, please return the product to the store where it was purchased for exchange; or, pack the unit in the original packing material with all accessories if applicable, a copy of your sales receipt and a Cashier's check or Money Order for \$7.00 (to cover shipping and handling costs) payable to Craig Electronics Inc. For consumers in Canada, please make sure that the cashier check or money order is redeemable through a U.S. bank. Ship your product freight pre-paid. Your unit will be repaired, replaced or if the unit can not be repaired or replaced, a refund will be forwarded to you within four weeks of receipt of your unit. Please ship your unit to:

Craig Electronics Inc.  
1160 NW 163 Drive  
Miami, FL 33169

This warranty is void if the product has been: a) Used in a commercial application or rental. b) Damaged through misuse, negligence, or abuse. c) Modified or repaired by anyone other than an authorized Craig service center. d) Damaged because it is improperly connected to any other equipment.

Note: This warranty does not cover: a) Ordinary adjustments as outlined in the Owner's Manual which can be performed by the customer. b) Damage to equipment not properly connected to the product. c) Any cost incurred in shipping the product for repair. d) Damage to the product not used in the USA.

This warranty is not transferable and only applies to the original purchase. Any implied warranties, including the warranty of merchantability, are limited in duration to the period of this expressed warranty and no warranty whether expressed or implied shall apply to the product thereafter.

Under no circumstance shall Craig be liable for any loss or consequential damage arising out of the use of this product. This warranty gives specific legal rights. However, you may have other rights which may vary from state to state. Some states do not allow limitations on implied warranties or exclusion of consequential damage. Therefore, these restrictions may not apply to you.

To Obtain Service on your Product  
email: [service@craigelectronics.com](mailto:service@craigelectronics.com)