

# naxa®

---

BLUETOOTH ALEXA VOICE CONTROL SPORT EARPHONE

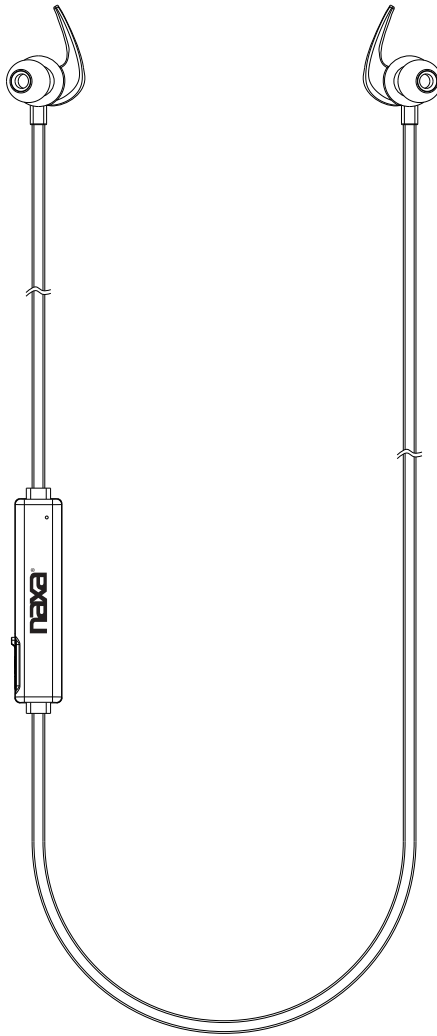

MODEL: NE-969

PLEASE READ CAREFULLY BEFORE OPERATING THIS EQUIPMENT  
KEEP IT IN A SAFE PLACE FOR FUTURE REFERENCE

## IMPORTANT SAFETY INSTRUCTIONS



CAUTION: TO REDUCE THE ELECTRIC SHOCK, DO NOT REMOVE THE COVER (OR BACK). NO USER SERVICEABLE PART INSIDE, REFER SERVICING TO QUALIFIED SERVICE PERSONNEL.



**DANGEROUS VOLTAGE:**The lightning flash with arrowhead symbol within an equilateral triangle is intended to alert the user to the presence of uninsulated “dangerous voltage” within the product’s enclosure that may be of sufficient magnitude to constitute a risk of electric shock to persons.



**ATTENTION:**The exclamation point within an equilateral triangle is intended to alert the user to the presence of important operating and maintenance (servicing) instructions in the literature accompanying the appliance.

**WARNING: TO PREVENT FIRE OR SHOCK HAZARD, DO NOT EXPOSE THIS UNIT TO RAIN OR MOISTURE.**



**WARNING:**

Cancer and Reproductive Harm-[www.P65Warnings.ca.gov](http://www.P65Warnings.ca.gov)

# IMPORTANT SAFETY INSTRUCTIONS

## **FCC STATEMENT:**

This device complies with part 15 of the FCC Rules. Operation is subject to the following two conditions:

- (1) This device may not cause harmful interference, and
- (2) This device must accept any interference received, including interference that may cause undesired operation.

## **FCC NOTICE:**

This equipment has been tested and found to comply with the limits for a Class B digital device, pursuant to Part 15 of the FCC Rules. These limits are designed to provide reasonable protection against harmful interference in a residential installation. This equipment generates, uses and can radiate radio frequency energy and, if not installed and used in accordance with the instructions, may cause harmful interference to radio communications. However, there is no guarantee that interference will not occur in a particular installation. If this equipment does cause harmful interference to radio or television reception, which can be determined by turning the equipment off and on, the user is encouraged to try to correct the interference by one or more of the following measures:

- Reorient or relocate the receiving antenna.
- Increase the separation between the equipment and receiver.
- Connect the equipment into an outlet on a circuit different from that to which the receiver is connected.
- Consult the dealer or an experienced radio/TV technician for help.

## **FCC WARNING:**

To assure continued operation, follow the attached installation instructions and use only shield cables when connecting to other devices. Changes or modifications not expressly approved by the party responsible for compliance could void the user's authority to operate the equipment.

# IMPORTANT SAFETY INSTRUCTIONS

Before using the unit, be sure to read all operating instruction carefully, please note that these are general precautions and may not pertain to your unit. For example, this unit may not have the capability to be connected to an outdoor antenna.

## **1. Read these instructions**

All the safety and operating instructions should be read before the appliance is operated.

## **2. Keep these instructions**

The safety and operating instructions should be kept for future reference.

## **3. Heed all warnings**

All warnings on the appliance and in the operating instructions should be adhered to.

## **4. Follow all instructions**

All operation and use instructions should be followed.

## **5. Do not use this apparatus near water**

The appliance should not be used near water; for example, near a bath tub, washbowl, kitchen sink, laundry tub, in a wet basement, or near a swimming pool.

## **6. Clean only with dry cloth**

The appliance should be cleaned only as recommended by the manufacturer.

## **7. Do not block any ventilation openings. Install in accordance with the manufacturer's instructions.**

Slots and openings in the cabinet and in the back or bottom are provided for ventilation, to ensure reliable operation of the product and to protect it from overheating. These openings must not be blocked or covered. The openings should never be blocked by placing the product on a bed, sofa, rug, or similar surface. This product should never be placed near or over a radiator or heat source. This product should not be placed in a built-in installation, such as a bookcase or rack unless proper ventilation is provided or the manufacturer's instructions have been adhered to.

## **8. Do not install near any heat sources such as radiators, heat registers, stoves, or other apparatus (including amplifiers) that produce heat.**

**9. Do not defeat the safety purpose of the polarized or grounding-type plug. A polarized plug has two blades with one wider than the other. A grounding type plug has two blades and a third grounding prong. The wide or the third prong are provided for your safety. If the provided plug does not fit into your outlet, consult an electrician for replacement of the obsolete outlet.**

**10. Protect the power cord from being walked on or pinched particularly at plugs, convenience receptacles, and the point where they exit from the apparatus.**

**11. Only use attachments / accessories specified by the manufacturer.**

**12. Use only with a cart, stand, tripod, bracket, or table specified by the manufacturer, or sold with the apparatus.**

**When a cart is used, use caution when moving the cart/apparatus combination to avoid injury from tip-over.**



Portable Cart Warning

An appliance and cart combination should be moved with care. Quick stop, excessive fore and uneven surfaces may cause the appliance and cart combination to overturn.

**13. Unplug this apparatus during lightning storms or when unused for long periods of time.**

To protect your product from a lightning storm, or when it is left unattended and unused for long periods of time, unplug it from the wall outlet and disconnect the antenna or cable system. This will prevent damage to the product due to lightning and power-line surges.

**14. Refer all servicing to qualified service personnel. Servicing is required when the apparatus has been damaged in any way, such as power-supply cord or plug is damaged, liquid has been spilled or objects have fallen into the apparatus, the apparatus has been exposed to rain or moisture, does not operate normally, or has been dropped.**

**15. Power source**

This product should be operated only from the type of power source indicated on the marking label. If you are not sure of the type of power supply to your home, consult your appliance dealer or local power company. For products intended to operate from battery power, or other source, refer to the operation instructions.

**16. Power lines**

An outside antenna system should not be located in the vicinity of overhead power lines or other electric light or power circuits, or where it can fall into such power lines or circuits. When installing an outside antenna system, extreme care should be taken to keep from touching such power lines or circuits as contact with them might be fatal.

**17. Overloading**

Do not overload wall outlets and extension cords as this can result in a risk of fire or electric shock.

**18. Object and liquid entry**

Never push objects of any kind into the product through openings as they may touch dangerous voltage points or short out parts that could result in fire or electric shock. Never spill or spray any type of liquid on the product.

## 19. Outdoor antenna grounding

If an outside antenna is connected to the product, be sure the antenna system is grounded so as to provide some protection against voltage surges and built up static charges. Section 810 of the National Electric Code ANSI/ NFPA 70 provides information with respect to proper grounding of the mast and supporting structure, grounding of the lead-in wire to an antenna discharge product, size of grounding conductors, location of antenna-discharge product, connection to grounding electrodes and requirements for the grounding electrodes.

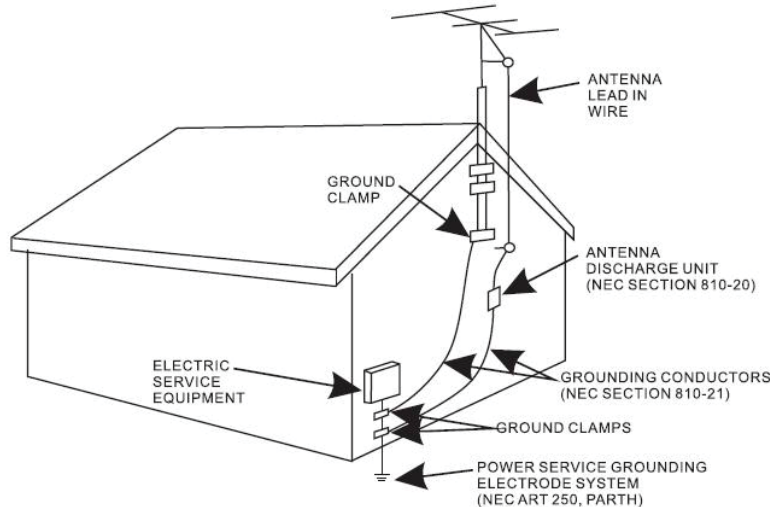

## 20. Service

Do not attempt to service this product yourself as opening or removing covers may expose you to dangerous voltage or other hazards. Refer all servicing to qualified service personnel.

## 21. Replacement parts

When replacement parts are required, be sure the service technician uses replacement parts specified by the manufacturer or those that have the same characteristics as the original parts. Unauthorized substitutions may result in fire or electric shock or other hazards.

## 22. Safety check

Upon completion of any service or repairs to this product, ask the service technician to perform safety checks to determine that the product is in proper operating condition.

## 23. Wall or ceiling mounting

The product should be mounted to a wall or ceiling only as recommended by the manufacturer.

## 24. Damage requiring service

Unplug this product from the wall outlet and refer service to qualified service personnel under the following conditions.

a)When the power- supply cord or plug is damaged.

- b) If liquid has been spilled or objects have fallen into the product.
- c) If the product has been exposed to rain or water.
- d) If the product does not operate normally by following the operating instructions. Adjust only those controls that are covered by the operating instructions, as an adjustment of other controls may result in damage and will require extensive work by a qualified technician to restore the product to its normal operation.
- e) If the product has been dropped or the cabinet has been damaged.
- f) When the product exhibits a distinct change in performance- this indicates a need for service.

**25. Note to CATV system installer**

This reminder is provided to call the CATV system installer's attention to Article 820-40 of the NEC that provides guidelines for proper grounding and, in particular, specifies that the cable ground shall be connected to the grounding system of the building, as close to the point of cable entry as practical.

**NOTE: Refer all servicing to qualified service personnel. Servicing is required when the unit has been damaged in any way such as the following: the power-supply cord or plug has been damaged, liquid has been spilled into unit, the unit has been exposed to rain or moisture, the unit has been dropped or the unit does not operate normally.**



To prevent possible hearing damage, do not listen at high volume levels for long periods.

**Warning:**

- Batteries (a battery pack or installed batteries) shall not be subject to excessive heat such as sunshine, fire or the like.  
The product is built with an internal rechargeable battery: do not expose the product to excessive heat such as sunshine, fire or the like.
- Changes or modifications not expressly approved by the manufacturer could void the user's authority to operate this device.
- Usage of controls or adjustments or performance of procedures other than those specified herein may result in hazardous exposure.
- Recharge the battery when the device indicates that the battery is low.
- It is highly recommended to charge the battery immediately when the battery is lower.
- To prolong the life of the battery, it is NOT recommended to use the device when it is charging.
- To prolong the life of the battery, consider recharging its battery at least once per month.

## PRODUCT OVERVIEW

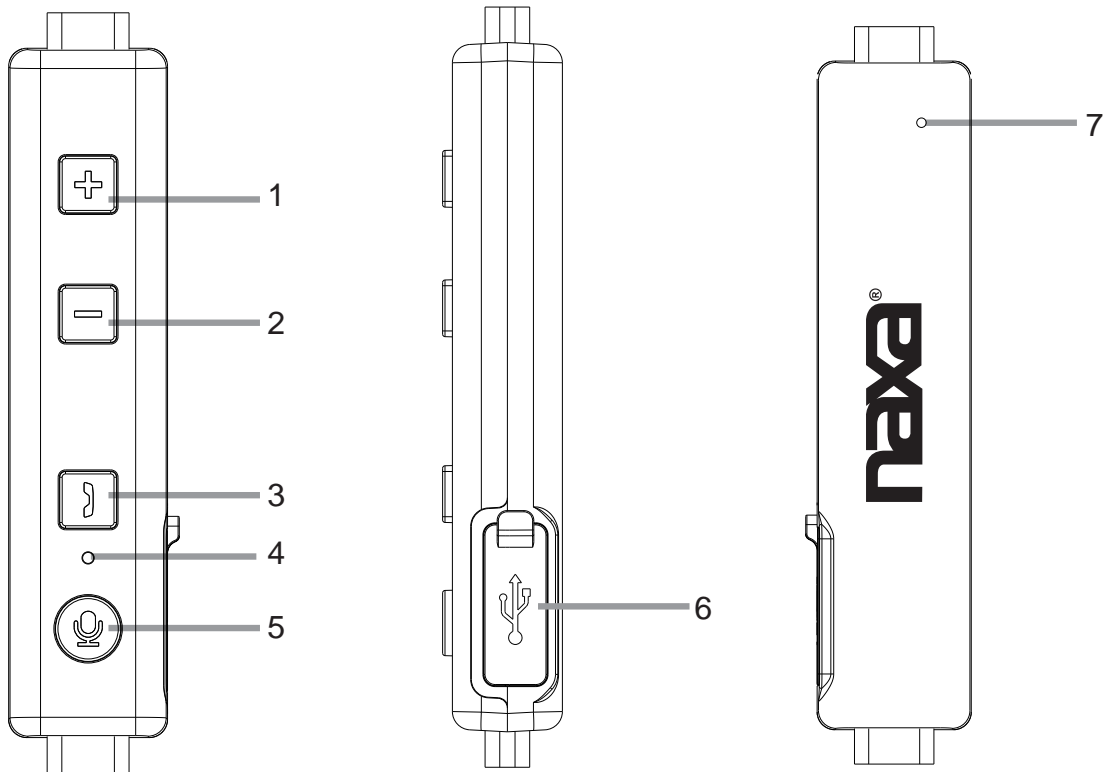

1. Volume Up/Previous Button
2. Volume Down/Next Button
3. Power On, Off / Hands-free/Play,Pause Button
4. Indicator for Charging, Pairing and Alexa
5. Alexa Voice Control Button
6. Micro USB Charging Jack Rubber Cover
7. Built-in Microphone



## POWER SOURCE

When the built-in battery is in low level, recharging it as illustrated below:

1. Uncover the rubber cover of the Micro USB Charging Port on the unit.
2. Connect one end of the USB cable to the Micro USB Charging Port.
3. Connect the opposite end of the USB cable to the USB port of the laptop or USB power adapter.

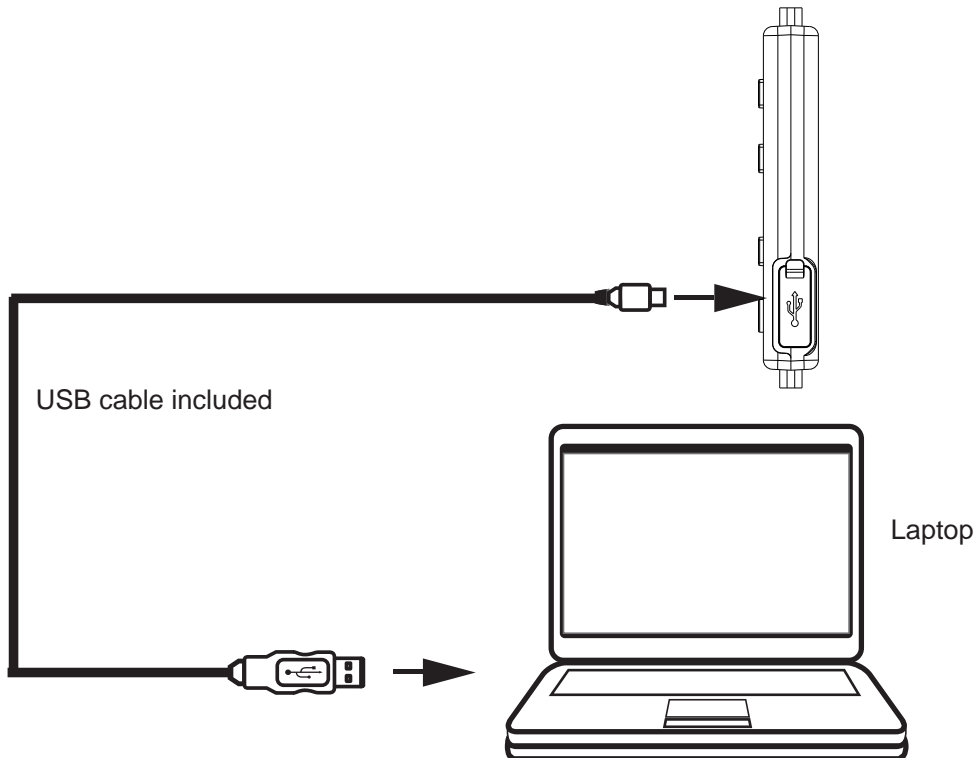







4. During charging, the charging indicator will turn Red, When finished charging, it will turn Blue.

### NOTE:

- A. Before first time use, charge it approximately 1 hour until the unit is fully charged.
- B. Recharge and store the unit within the temperature range of 5°C~35°C (40°F~95°F).
- C. Do not charge longer than 24 hours. Excessive charging or running the unit until the battery fully drains will damage battery. Battery life will be extended if you keep the battery fully charged.
- D. Battery life naturally shortens slowly over time.
- E. The rechargeable battery incorporated in this product is not user replaceable.

## BLUETOOTH OPERATION

1. Press and hold the  button to power on the unit, the unit will send a voice "power on, pairing".  
The LED indicator blinks fast with blue and red color.
2. Activate the Bluetooth function on your Bluetooth device (mobile phone or music device).  
Please refer to the manufacturer's instructions of your device.
3. Once the unit is searched, select the pairing name from the pairing list.  
**NOTE:** The pairing name is " **NE-969 - XXX** ". Here "XXX" stands for the different ID for different unit.
4. After successful connection, there will be voice indicating "Source Connected".  
The LED indicator will blink blue about 5 seconds a time.
5. If pairing is unsuccessful, turn off the unit first and follow the above steps to retry.
6. During playing:
  - Press the  button to pause, press it again to play normally.
  - Press the - or + button repeatedly to adjust the volume.
  - Press and hold the + or - button to skip to previous or next track.
7. During an incoming call:
  - Press the  button to answer the incoming call.
  - Press and hold the  button to transforming the audio between the connected phone and the unit.
  - Press the  button again to hang up after calling.
  - Press and hold the  button to refuse answering the incoming call.
  - Double press the  button to redial the last dialed phone number.

# SETUP

## APP DOWNLOAD AND INSTALLATION

- Download the App from Apple App store for iOS devies.
- Download the App from Google Play store for Android devices.
- The App icon will appear as the icon on right after successful installation.
- The following operations base on iOS system.

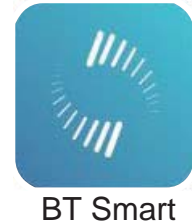

## CONNECTION

1. Press and hold the  button to power on the unit, the unit will send a voice "power on, pairing". The LED indicator blinks fast with blue and red color.
2. Activate the WiFi on your device(smart phone or tablet with WiFi function), connect it to the desired WiFi network.

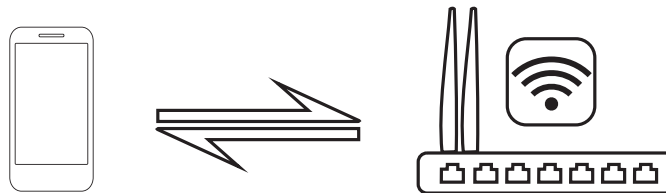

3. Tap the App icon on your device. The user interface will appear as below.

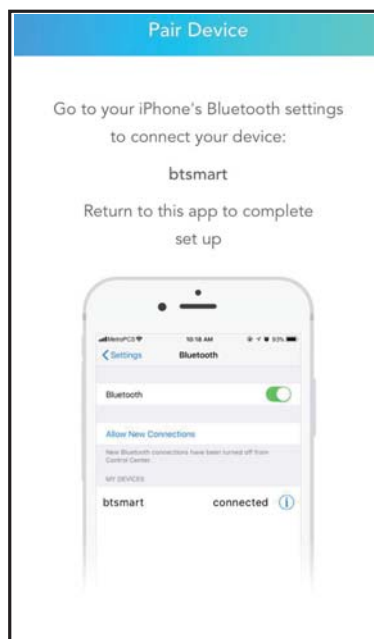

4. Go to the Bluetooth setting on your phone.

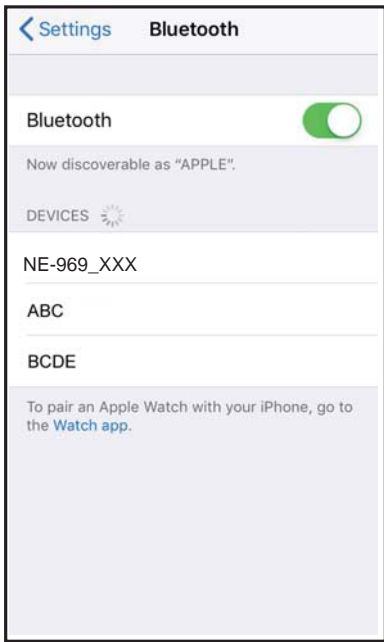

5. Select "NE-969\_XXX" and make connection.



6. Go back to App, the interface will appear as below, after a few seconds, the unit will pair with your phone successfully.

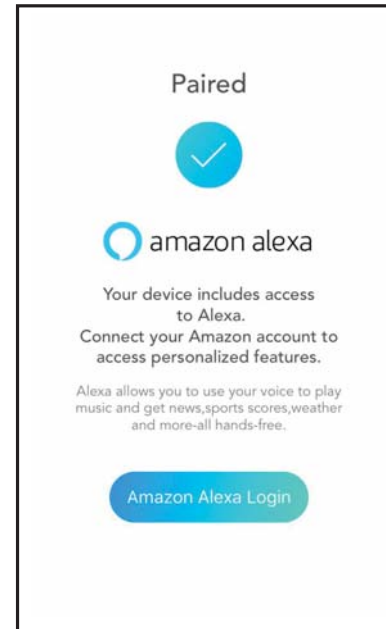
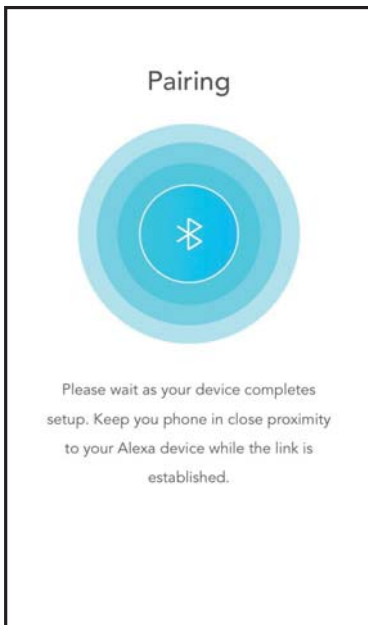

## NOTE:

If the below interface appears, try to pair again by the previous steps. Delete the pairing name "NE-969\_XXX" and search and pair again.

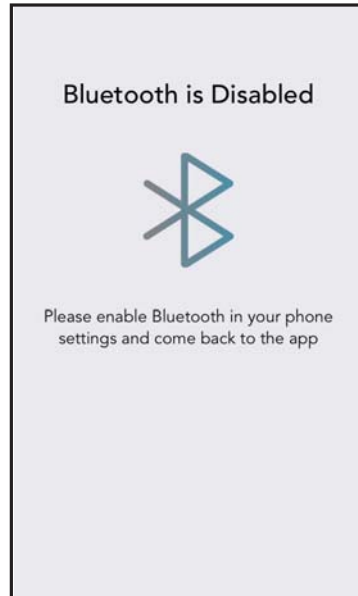

7. After successful pairing, tap "Amazon Alexa Login" to continue. The sign in window will appear, input your account and password to log in Amazon. If you do not have an account, tap "Create a new Amazon account", follow the interface instructions to create a account.

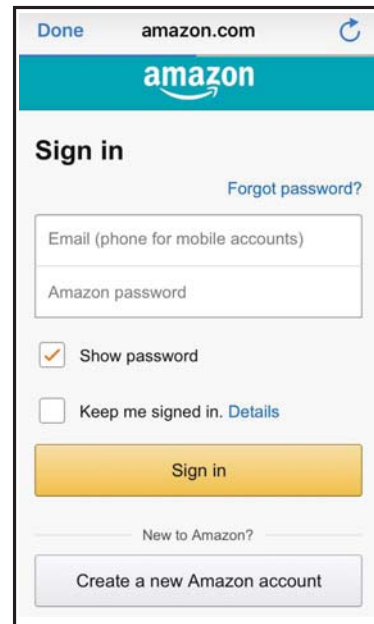
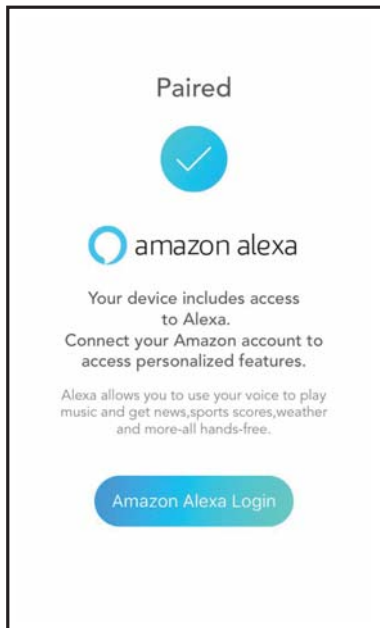

8. When the following page appears, tap the "Allow" Button to log in Amazon.

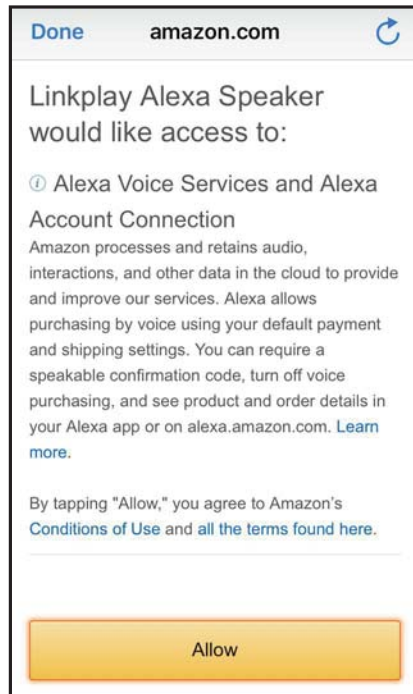

9. After log in, the following page will appear, select your country and tap "Next" to go to next interface, then tap "Done" to continue.

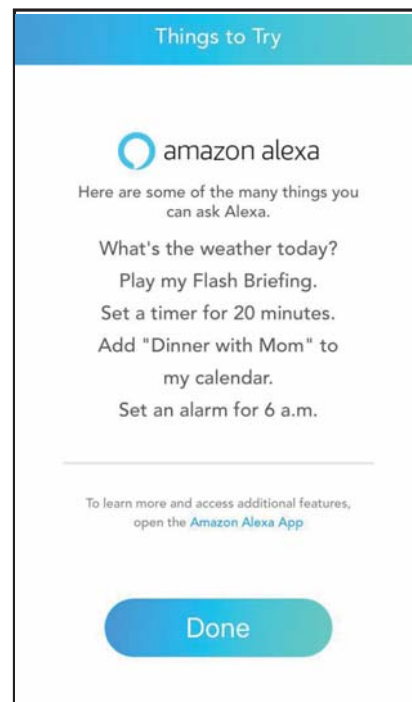

10. The home page will appear as below. Tap the  on home page or press the  button to activate the Amazon Alexa voice function, then speak to the Microphone on the unit for operation.

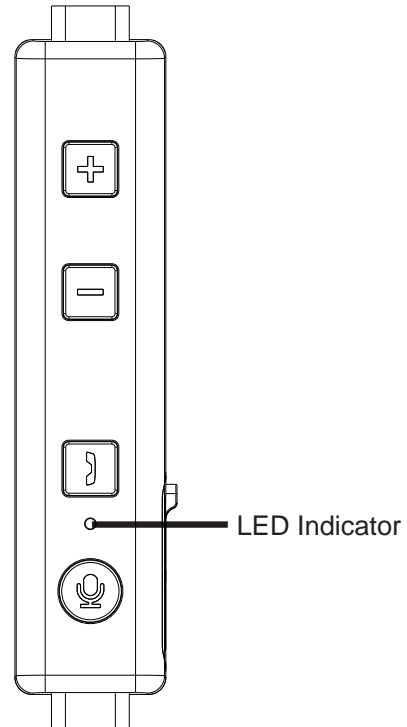
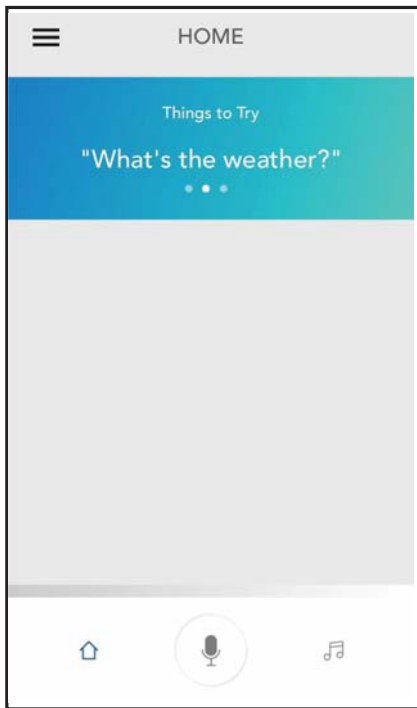

11. Tap the  on home page, the below page will appear. Tap "Amazon Alexa" to log in or sign out Amazon Alexa. Tap "Amazon Alexa Language" to select desired language. Tap "Device Information" to check the device information. Tap "Send Feedback" to edit and send feedback.

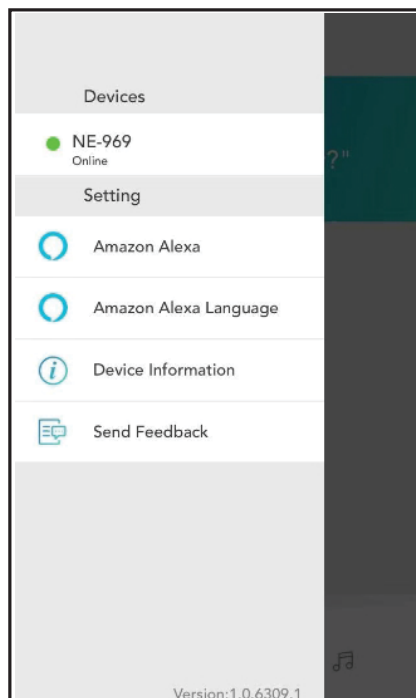

## AMAZON ALEXA VOICE CONTROL

### Voice Control of Amazon Alexa:

1. Press the  Button on the unit, then you can ask the unit through the built-in Mic. The unit will answer you by audible reply. The typical question and answer will be:

Q: What's the time now?

A: It's XX (XX=Current time) o'clock now.

Q: What's the weather like?

A: The weather is not so cold.

Q: What's the news today?

A: Here is the flash briefing.

2. During music playing, press the  Button on the unit, then send your voice command:

- Voice command: ---play the song <XX> (XX=Name of the desired song)!  
Action: The song will be played.
- Voice command: --- pause/stop the song!  
Action: The song will be paused or stopped.
- Voice command: --- continue to play!  
Action: The song will continue to play.
- Voice command: --- volume up!  
Action: The volume will increase.
- Voice command: --- volume down!  
Action: The volume will decrease.
- Voice command: --- fastforward!  
Action: The track will be fastwarded.
- Voice command: --- rewind!  
Action: The track will rewind.
- Voice command: --- previous!  
Action: The track will skip to previous track.
- Voice command: --- next!  
Action: The track will skip to next track.



## TROUBLESHOOTING

Check the following symptoms before requesting service:

<b>SYMPTOM</b>	<b>POSSIBLE CAUSE</b>	<b>POSSIBLE SOLUTION</b>
Can't power on	Built in battery drained	Recharge the battery
No sound or sound weak	Volume level in minimum position	Press + Button to raise volume
	Volume level of paired/connected device is in low level	Raise the volume level of the connected device
Sound distortion	Volume level too high	Press - Button to reduce volume
	Volume level of the connected device too high	Reduce the volume level of the connected device
Wi-Fi not functioning	The router was in power off mode	Power on your Wi-Fi router
Amazon Alexa not functioning	The unit is not in the Amazon Alexa operation mode	Power on the unit and enter to Amazon Alexa operate mode

## SPECIFICATIONS

Bluetooth version:	4.2
Bluetooth Working Range:	about 32 Feet in open area
Wifi Operation Distance:	about 96 Feet in open area
Operation Time:	about 4 hour (in 50% volume)

## PACKAGES

- 1 X Main Unit
- 1 X User Manual
- 1 X USB Charging Cable
- 2 X Ear Gels

**SPECIFICATIONS AND ACCESSORIES ARE SUBJECT TO CHANGE  
WITHOUT NOTICE**