



Valued Quality. Delivered.

TEST REPORT

Report No.: 15040181HKG-001

WowWee Group Limited

Application
For
Certification
(Original Grant)
(FCC ID: OKP0820N)
(IC: 7091A-0820N)

Transceiver

Prepared and Checked by:

Approved by:

Signed on the File
Wong Kwok Yeung, Kenneth
Lead Engineer

Chan Chi Hung, Terry
Senior Supervisor
Date: July 17, 2015

- Intertek's standard Terms and Conditions can be obtained at our website <http://www.intertek.com/terms/>.
- This report shall not be reproduced, except in full.
- This report is for the exclusive use of Intertek's Client and is provided pursuant to the agreement between Intertek and its Client. Intertek's responsibility and liability are limited to the terms and conditions of the agreement. Intertek assumes no liability to any party, other than to the Client in accordance with the agreement, for any loss, expense or damage occasioned by the use of this report. Only the Client is authorized to permit copying or distribution of this report and then only in its entirety. Any use of the Intertek name or one of its marks for the sale or advertisement of the tested material, product or service must first be approved in writing by Intertek. The observations and test results in this report are relevant only to the sample tested. This report by itself does not imply that the material, product, or service is or has ever been under an Intertek certification program.

Intertek Testing Services Hong Kong Ltd.

2/F., Garment Centre, 576 Castle Peak Road, Kowloon, Hong Kong.

Tel: (852) 2173 8888 Fax: (852) 2785 5487 Website: www.hk.intertek-ettsemko.com



Valued Quality. Delivered.

GENERAL INFORMATION

Grantee:	WowWee Group Limited
Grantee Address:	Energy Plaza, Suite 301A-C, 92 Granville Road, Tsim Sha Tsui East, Kowloon, Hong Kong.
Contact Person:	Dennis Tsoi
Tel:	(852) 2739 5288
Fax:	(852) 2723 3425
e-mail:	dennistsoi@wowwee.com.hk
Manufacturer:	Shao Guan Early Light International Co., Ltd.
Manufacturer Address:	XURI Toy industry zone 6km, The western suburbs of Shaoguan City, Shaoguan, Guangdong, China
Brand Name:	WowWee
FCC Model:	0820N
FCC Additional Model:	0821, 0822, 0823, 0824, 0825, 0827, 0847, 0848
IC Model:	0820N
Type of EUT:	Transceiver
Description of EUT:	Mip Assorted (0820N) Mip White and Black color (0821) Mip Red color (0822) Mip Yellow color (0823) Mip Blue color (0824) Mip Black and Silver (0825) Mip Gold color (0827) Mip Metallic Silver (0847) Mip Metallic Pink (0848)
Serial Number:	N/A
FCC ID / IC:	OKP0820N / 7091A-0820N
Date of Sample Submitted:	April 02, 2015
Date of Test:	April 02, 2015 to April 29, 2015
Report No.:	15040181HKG-001
Report Date:	July 17, 2015
Environmental Conditions:	Temperature: +10 to 40°C Humidity: 10 to 90%

Report No.: 15040181HKG-001

FCC ID: OKP0820N

IC: 7091A-0820N

Intertek Testing Services Hong Kong Ltd.

2/F., Garment Centre, 576 Castle Peak Road, Kowloon, Hong Kong.

Tel: (852) 2173 8888 Fax: (852) 2785 5487 Website: www.hk.intertek-ettsemko.com



Valued Quality. Delivered.

SUMMARY OF TEST RESULT

TEST SPECIFICATION	REFERENCE	RESULTS
Radiated Emission Radiated Emission on the Bandedge	15.249, 15.209 / RSS-210 A2.9, RSS-210 2.5	Pass
Radiated Emission in Restricted Bands	15.205 / RSS-210 2.2	Pass

The equipment under test is found to be complying with the following standards:
FCC Part 15, October 1, 2013 Edition
RSS-210 Issue 8, December 2010
RSS-Gen Issue 4, December 2014

- Note: 1. The EUT uses a permanently attached antenna which, in accordance to section 15.203, is considered sufficient to comply with the provisions of this section.
2. Pursuant to FCC part 15 Section 15.215(c), the 20 dB bandwidth of the emission was contained within the frequency band designated (mentioned as above) which the EUT operated. The effects, if any, from frequency sweeping, frequency hopping, other modulation techniques and frequency stability over expected variations in temperature and supply voltage were considered.

Report No.: 15040181HKG-001
FCC ID: OKP0820N
IC: 7091A-0820N

ii

Table of Contents

1.0	<u>General Description</u>	1
1.1	Product Description	1
1.2	Related Submittal(s) Grants.....	1
1.3	Test Methodology	1
1.4	Test Facility	2
2.0	<u>System Test Configuration</u>	3
2.1	Justification.....	3
2.2	EUT Exercising Software.....	3
2.3	Special Accessories	3
2.4	Measurement Uncertainty.....	3
2.5	Support Equipment List and Description.....	3
3.0	<u>Emission Results</u>	4
3.1	Field Strength Calculation.....	4
3.2	Radiated Emission Configuration Photograph	5
3.3	Radiated Emission Data	5
4.0	<u>Equipment Photographs</u>	9
5.0	<u>Product Labelling</u>	9
6.0	<u>Technical Specifications</u>	9
7.0	<u>Instruction Manual</u>	9
8.0	<u>Miscellaneous Information</u>	10
8.1	Radiated Emission on the Bandedge.....	10
8.2	Discussion of Pulse Desensitization	13
8.3	Calculation of Average Factor.....	13
8.4	Emissions Test Procedures	13
8.5	Occupied Bandwidth.....	17
9.0	<u>Confidentiality Request</u>	18
10.0	<u>Equipment List</u>	18



Valued Quality. Delivered.

1.0 General Description

1.1 Product Description

The Equipment Under Test(EUT) is a 2.4GHz Bluetooth 4.0 transceiver (Robot), which is operating at 2402MHz to 2480MHz (40 Channels with 2MHz channel spacing). The EUT is powered by 6VDC (4 x 1.5V “AAA” size batteries). The EUT has a power ON/OFF switch, a pairing button and a LED. When the EUT is switched ON, the LED will flash and waiting corresponding controller(for example: Android mobile or Iphone). After pairing , the LED will stay lit, and the EUT can be controlled to move forward, backward, left and right by the corresponding Bluetooth device.

The Model: 0821, 0822, 0823, 0824, 0825, 0827, 0847 and 0848 are the same as the Model: 0820N in hardware aspect. The models are different in color only.

Antenna Type: Internal, Integral

For electronic filing, the brief circuit description is saved with filename: descri.pdf.

1.2 Related Submittal(s) Grants

This is a single application for certification of a transceiver.

1.3 Test Methodology

Radiated emission measurements was performed according to the procedures in ANSI C63.10 (2013). All radiated measurements were performed in an 3m Chamber. Preliminary scans were performed in the 3m Chamber only to determine worst case modes. All radiated tests were performed at an antenna to EUT distance of 3 meters, unless stated otherwise in the “**Justification Section**” of this Application.



Valued Quality. Delivered.

1.4 Test Facility

The 3m Chamber and conducted measurement facility used to collect the radiated data is located at Workshop No. 3, G/F., World-Wide Industrial Centre, 43-47 Shan Mei Street, Fo Tan, Sha Tin, N.T., Hong Kong. This test facility and site measurement data have been placed on file with the FCC and IC.

2.0 **System Test Configuration**

2.1 Justification

The system was configured for testing in a typical fashion (as a customer would normally use it), and in the confines as outlined in ANSI C63.10 (2013).

The device was powered by new 6VDC (4 x 1.5V “AAA” batteries).

For maximizing emissions, the EUT was rotated through 360°, the antenna height was varied from 1 meter to 4 meters above the ground plane, and the antenna polarization was changed. This step by step procedure for maximizing emissions led to the data reported in Exhibit 3.0.

The unit was operated standalone and placed in the center of the turntable.

The equipment under test (EUT) was configured for testing in a typical fashion (as a customer would normally use it). The EUT was mounted to a plastic stand if necessary and placed on the wooden turntable, which enabled the engineer to maximize emissions through its placement in the three orthogonal axes.

2.2 EUT Exercising Software

There was no special software to exercise the device. Once the unit is powered up, it transmits the RF signal continuously.

2.3 Special Accessories

There are no special accessories necessary for compliance of this product.

2.4 Measurement Uncertainty

When determining of the test conclusion, the Measurement Uncertainty of test has been considered.

Uncertainty and Compliance - Unless the standard specifically states that measured values are to be extended by the measurement uncertainty in determining compliance, all compliance determinations are based on the actual measured value.

2.5 Support Equipment List and Description

N/A.

3.0 Emission Results

Data is included of the worst case configuration (the configuration which resulted in the highest emission levels). A sample calculation, configuration photographs and data tables of the emissions are included.

3.1 Field Strength Calculation

The field strength is calculated by adding the Antenna Factor and Cable Factor, and subtracting the Amplifier Gain (if any), Average Factor (optional) from the measured reading. The basic equation with a sample calculation is as follows:

$$FS = RA + AF + CF - AG - AV$$

where

- FS = Field Strength in dB μ V/m
- RA = Receiver Amplitude (including preamplifier) in dB μ V
- CF = Cable Attenuation Factor in dB
- AF = Antenna Factor in dB
- AG = Amplifier Gain in dB
- AV = Average Factor in dB

In the following table(s), the reading shown on the data table reflects the preamplifier gain. An example for the calculations in the following table is as follows:

$$FS = RR + LF$$

where

- FS = Field Strength in dB μ V/m
- RR = RA - AG - AV in dB μ V
- LF = CF + AF in dB

Assume a receiver reading of 52.0 dB μ V is obtained. The antenna factor of 7.4 dB and cable factor of 1.6 dB are added. The amplifier gain of 29 dB and average factor of 5 dB are subtracted, giving a field strength of 32 dB μ V/m. This value in dB μ V/m was converted to its corresponding level in μ V/m.

RA = 52.0 dB μ V/m	
AF = 7.4 dB	RR = 18.0 dB μ V
CF = 1.6 dB	LF = 9.0 dB
AG = 29.0 dB	
AV = 5.0 dB	
FS = RR + LF	
FS = 18 + 9 = 27 dB μ V/m	

$$\text{Level in } \mu\text{V/m} = \text{Common Antilogarithm } [(27 \text{ dB}\mu\text{V/m})/20] = 22.4 \mu\text{V/m}$$



Valued Quality. Delivered.

3.2 Radiated Emission Configuration Photograph

The worst case in radiated emission was found at 12400.0 MHz

For electronic filing, the worst case radiated emission configuration photographs are saved with filename: radiated photos.pdf.

3.3 Radiated Emission Data

The data on the following page lists the significant emission frequencies, the limit and the margin of compliance. Numbers with a minus sign are below the limit.

Judgment: Passed by 0.2 dB



Valued Quality. Delivered.

Applicant: WowWee Group Limited

Date of Test: April 29, 2015

Model: 0820N

Worst-Case Operating Mode: Transmitting (Bluetooth 3.0)

Table 1
Radiated Emissions
Pursuant to FCC Part 15 Section 15.249 / RSS-210 A2.9 Requirement

Lowest Channel

Polarization	Frequency (MHz)	Reading (dBµV)	Pre-Amp Gain (dB)	Antenna Factor (dB)	Net at 3m - Peak (dBµV/m)	Average Factor (dB)	Calculated at 3m (dBµV/m)	Average Limit at 3m (dBµV/m)	Margin (dB)
H	2402.000	91.2	33	29.4	87.6	0	87.6	94.0	-6.4
V	4804.000	51.3	33	34.9	53.2	0	53.2	54.0	-0.8
V	7206.000	47.2	33	37.9	52.1	0	52.1	54.0	-1.9
V	9608.000	44.5	33	40.4	51.9	0	51.9	54.0	-2.1
V	12010.000	45.9	33	40.5	53.4	0	53.4	54.0	-0.6
V	14412.000	45.9	33	40.0	52.9	0	52.9	54.0	-1.1

Polarization	Frequency (MHz)	Reading (dBµV)	Pre-Amp Gain (dB)	Antenna Factor (dB)	Net at 3m - Peak (dBµV/m)	Peak Limit at 3m (dBµV/m)	Margin (dB)
H	2402.000	91.2	33	29.4	87.6	114.0	-26.4
V	4804.000	51.3	33	34.9	53.2	74.0	-20.8
V	7206.000	47.2	33	37.9	52.1	74.0	-21.9
V	9608.000	44.5	33	40.4	51.9	74.0	-22.1
V	12010.000	45.9	33	40.5	53.4	74.0	-20.6
V	14412.000	45.9	33	40.0	52.9	74.0	-21.1

- NOTES: 1. Peak Detector Data unless otherwise stated.
2. All measurements were made at 3 meters. Harmonic emissions not detected at the 3-meter distances were measured at 0.3-meter and an inverse proportional extrapolation was performed to compare the signal level to the 3-meter limit. No other harmonic emissions than those reported were detected at a test distance of 0.3-meter.
3. Negative signing in the column shows value below limit.
4. Horn antenna is used for the emission over 1000MHz.
5. Emission (the row indicated by **bold italic**) within the restricted band meets the requirement of FCC Part 15 Section 15.205 / RSS-210 Section 2.2.
6. Measurement Uncertainty is ±5.3dB at a level of confidence of 95%.

Applicant: WowWee Group Limited

Date of Test: April 29, 2015

Model: 0820N

Worst-Case Operating Mode: Transmitting (Bluetooth 3.0)

Table 2
Radiated Emissions
Pursuant to FCC Part 15 Section 15.249 / RSS-210 A2.9 Requirement

Middle Channel

Polarization	Frequency (MHz)	Reading (dB μ V)	Pre-Amp Gain (dB)	Antenna Factor (dB)	Net at 3m - Peak (dB μ V/m)	Average Factor (dB)	Calculated at 3m (dB μ V/m)	Average Limit at 3m (dB μ V/m)	Margin (dB)
H	2440.000	91.5	33	29.4	87.9	0	87.9	94.0	-6.1
V	4880.000	51.4	33	34.9	53.3	0	53.3	54.0	-0.7
V	7320.000	48.2	33	37.9	53.1	0	53.1	54.0	-0.9
V	9760.000	44.7	33	40.4	52.1	0	52.1	54.0	-1.9
V	12200.000	44.7	33	40.5	52.2	0	52.2	54.0	-1.8
V	14640.000	47.7	33	38.4	53.1	0	53.1	54.0	-0.9

Polarization	Frequency (MHz)	Reading (dB μ V)	Pre-Amp Gain (dB)	Antenna Factor (dB)	Net at 3m - Peak (dB μ V/m)	Peak Limit at 3m (dB μ V/m)	Margin (dB)
H	2440.000	91.5	33	29.4	87.9	114.0	-26.1
V	4880.000	51.4	33	34.9	53.3	74.0	-20.7
V	7320.000	48.2	33	37.9	53.1	74.0	-20.9
V	9760.000	44.7	33	40.4	52.1	74.0	-21.9
V	12200.000	44.7	33	40.5	52.2	74.0	-21.8
V	14640.000	47.7	33	38.4	53.1	74.0	-20.9

- NOTES: 1. Peak Detector Data unless otherwise stated.
2. All measurements were made at 3 meters. Harmonic emissions not detected at the 3-meter distances were measured at 0.3-meter and an inverse proportional extrapolation was performed to compare the signal level to the 3-meter limit. No other harmonic emissions than those reported were detected at a test distance of 0.3-meter.
3. Negative signing in the column shows value below limit.
4. Horn antenna is used for the emission over 1000MHz.
5. Emission (the row indicated by ***bold italic***) within the restricted band meets the requirement of FCC Part 15 Section 15.205 / RSS-210 Section 2.2.
6. Measurement Uncertainty is ± 5.3 dB at a level of confidence of 95%.



Valued Quality. Delivered.

Applicant: WowWee Group Limited

Date of Test: April 29, 2015

Model: 0820N

Worst-Case Operating Mode: Transmitting (Bluetooth 3.0)

Table 3
Radiated Emissions
Pursuant to FCC Part 15 Section 15.249 / RSS-210 A2.9 Requirement

Highest Channel

Polarization	Frequency (MHz)	Reading (dBµV)	Pre-Amp Gain (dB)	Antenna Factor (dB)	Net at 3m - Peak (dBµV/m)	Average Factor (dB)	Calculated at 3m (dBµV/m)	Average Limit at 3m (dBµV/m)	Margin (dB)
H	2480.000	91.9	33	29.4	88.3	0	88.3	94.0	-5.7
V	4960.000	50.2	33	34.9	52.1	0	52.1	54.0	-1.9
V	7440.000	48.0	33	37.9	52.9	0	52.9	54.0	-1.1
V	9920.000	45.7	33	40.4	53.1	0	53.1	54.0	-0.9
V	12400.000	46.3	33	40.5	53.8	0	53.8	54.0	-0.2
V	14880.000	47.9	33	38.4	53.3	0	53.3	54.0	-0.7

Polarization	Frequency (MHz)	Reading (dBµV)	Pre-Amp Gain (dB)	Antenna Factor (dB)	Net at 3m - Peak (dBµV/m)	Peak Limit at 3m (dBµV/m)	Margin (dB)
H	2480.000	91.9	33	29.4	88.3	114.0	-25.7
V	4960.000	50.2	33	34.9	52.1	74.0	-21.9
V	7440.000	48.0	33	37.9	52.9	74.0	-21.1
V	9920.000	45.7	33	40.4	53.1	74.0	-20.9
V	12400.000	46.3	33	40.5	53.8	74.0	-20.2
V	14880.000	47.9	33	38.4	53.3	74.0	-20.7

- NOTES: 1. Peak Detector Data unless otherwise stated.
2. All measurements were made at 3 meters. Harmonic emissions not detected at the 3-meter distances were measured at 0.3-meter and an inverse proportional extrapolation was performed to compare the signal level to the 3-meter limit. No other harmonic emissions than those reported were detected at a test distance of 0.3-meter.
3. Negative sign in the column shows value below limit.
4. Horn antenna is used for the emission over 1000MHz.
5. Emission (the row indicated by ***bold italic***) within the restricted band meets the requirement of FCC Part 15 Section 15.205 / RSS-210 Section 2.2.
6. Measurement Uncertainty is ±5.3dB at a level of confidence of 95%.



Valued Quality. Delivered.

4.0 **Equipment Photographs**

For electronic filing, the photographs are saved with filename: external photos.pdf and internal photos.pdf.

5.0 **Product Labelling**

For electronics filing, the FCC ID label artwork and the label location are saved with filename: label.pdf.

6.0 **Technical Specifications**

For electronic filing, the block diagram and schematic of the tested EUT are saved with filename: block.pdf and circuit.pdf respectively.

7.0 **Instruction Manual**

For electronic filing, a preliminary copy of the Instruction Manual is saved with filename: manual.pdf.

This manual will be provided to the end-user with each unit sold/leased in the United States and Canada.



Valued Quality. Delivered.

8.0 **Miscellaneous Information**

The miscellaneous information includes details of the test procedure and measured bandwidth / calculation of factor such as pulse desensitization and averaging factor (calculation and timing diagram).

8.1 Radiated Emission on the Bandedge

From the following plots, they show that the fundamental emissions are confined in the specified band (2400MHz to 2483.5MHz). In case of the fundamental emissions are within two standard bandwidths from the bandedge, the delta measurement technique is used for determining bandedge compliance. Standard bandwidth is the bandwidth specified by ANSI C63.10 (2013) for frequency being measured.

Emissions radiated outside of the specified frequency bands, except harmonics, are attenuated by 50dB below the level of the fundamental or to the general radiated emissions limits in Section 15.209, whichever is the lesser attenuation, which meet the requirement of part 15.249(d).

Peak Measurement

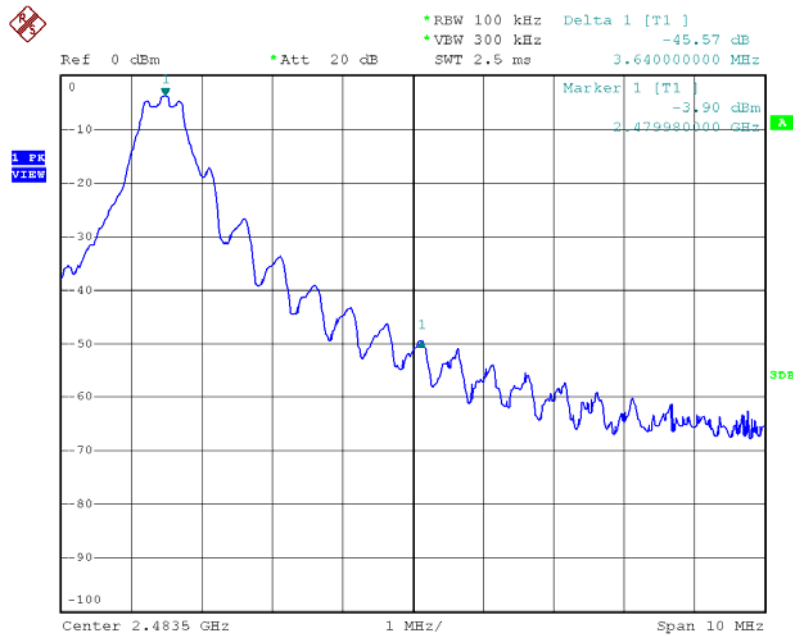
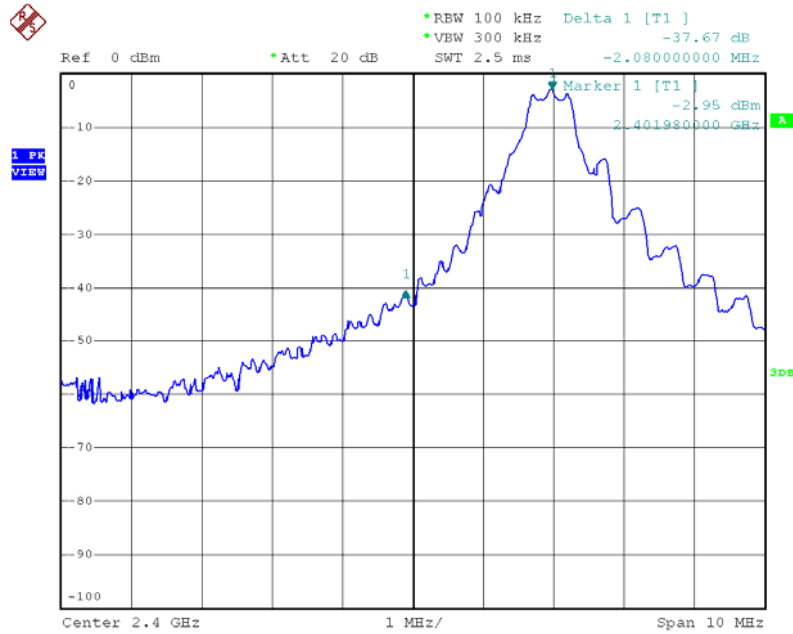

Peak Measurement

Bandedge compliance is determined by applying marker-delta method, i.e. (Bandedge Plot).

Lower bandedge

Peak Resultant field strength = Fundamental emissions (peak value) – delta from the plot

$$=87.6\text{dB}\mu\text{V/m} - 37.7\text{ dB}$$

$$=49.9\text{ dB}\mu\text{V/m}$$

Average Resultant field strength = Fundamental emissions (average value) – delta from the plot

$$=87.6\text{ dB}\mu\text{V/m} - 37.7\text{ dB}$$

$$=49.9\text{ dB}\mu\text{V/m}$$

Upper bandedge

Peak Resultant field strength = Fundamental emissions (peak value) – delta from the plot

$$=88.3\text{ dB}\mu\text{V/m} - 45.6\text{ dB}$$

$$=42.7\text{ dB}\mu\text{V/m}$$

Average Resultant field strength = Fundamental emissions (average value) – delta from the plot

$$=88.3\text{ dB}\mu\text{V/m} - 45.6\text{ dB}$$

$$=42.7\text{ dB}\mu\text{V/m}$$

The resultant field strength meets the general radiated emission limit in Section 15.209, which does not exceed 74 dB μ V/m (Peak Limit) and 54 dB μ V/m (Average Limit).



Valued Quality. Delivered.

8.2 Discussion of Pulse Desensitization

Pulse desensitivity is not applicable for this device. The effective period (Teff) is approximately 0.8ms for a digital "1" bit which illustrated on technical specification, with a resolution bandwidth (3dB) of 30kHz, so the pulse desensitivity factor is 0dB.

8.3 Calculation of Average Factor

It is not necessary to apply average factor as the measured (peak) data has been complied with average limit of the radiated emission.

8.4 Emissions Test Procedures

The following is a description of the test procedure used by Intertek Testing Services Hong Kong Ltd. in the measurements of transmitter operating under the Part 15, Subpart C rules.

The transmitting equipment under test (EUT) is placed on a wooden turntable which is four feet in diameter and approximately 0.8m in height above the ground plane for emission measurement at or below 1GHz and 1.5m in height above the ground plane for emission measurement above 1GHz. During the radiated emissions test, the turntable is rotated and any cables leaving the EUT are manipulated to find the configuration resulting in maximum emissions. The EUT is adjusted through all three orthogonal axis to obtain maximum emission levels. The antenna height and polarization are also varied during the testing to search for maximum signal levels. The height of the antenna is varied from one to four meters.

Detector function for radiated emissions is in peak mode. Average readings, when required, are taken by measuring the duty cycle of the equipment under test and subtracting the corresponding amount in dB from the measured peak readings. A detailed description for the calculation of the average factor can be found in Exhibit 8.3.

The frequency range scanned is from the lowest radio frequency signal generated in the device which is greater than 9 kHz to the tenth harmonic of the highest fundamental frequency or 40 GHz, whichever is lower.



Valued Quality. Delivered.

8.4 Emissions Test Procedures (cont'd)

The EUT is warmed up for 15 minutes prior to the test.

AC power to the unit is varied from 85% to 115% nominal and variation in the fundamental emission field strength is recorded. If battery powered, a new, fully charged battery is used.

Conducted measurements were made as described in ANSI C63.10 (2013).

The IF bandwidth used for measurement of radiated signal strength was 100 kHz or greater when frequency is below 1000 MHz. Where pulsed transmissions of short enough pulse duration warrant, a greater bandwidth is selected according to the recommendations of Hewlett Packard Application Note 150-2. A discussion of whether pulse desensitivity is applicable to this unit is included in this report (See Exhibit 8.1). Above 1000 MHz, a resolution bandwidth of 3 MHz is used.

Transmitter measurements are normally conducted at a measurement distance of three meters. However, to assure low enough noise floor in the forbidden bands and above 1 GHz, signals are acquired at a distance of one meter or less. All measurements are extrapolated to three meters using inverse scaling, unless otherwise reported. Measurements taken at a closer distance are so marked.

8.4.1 Radiated Emission Test Setup

The figure below shows the test setup, which is utilized to make these measurements.

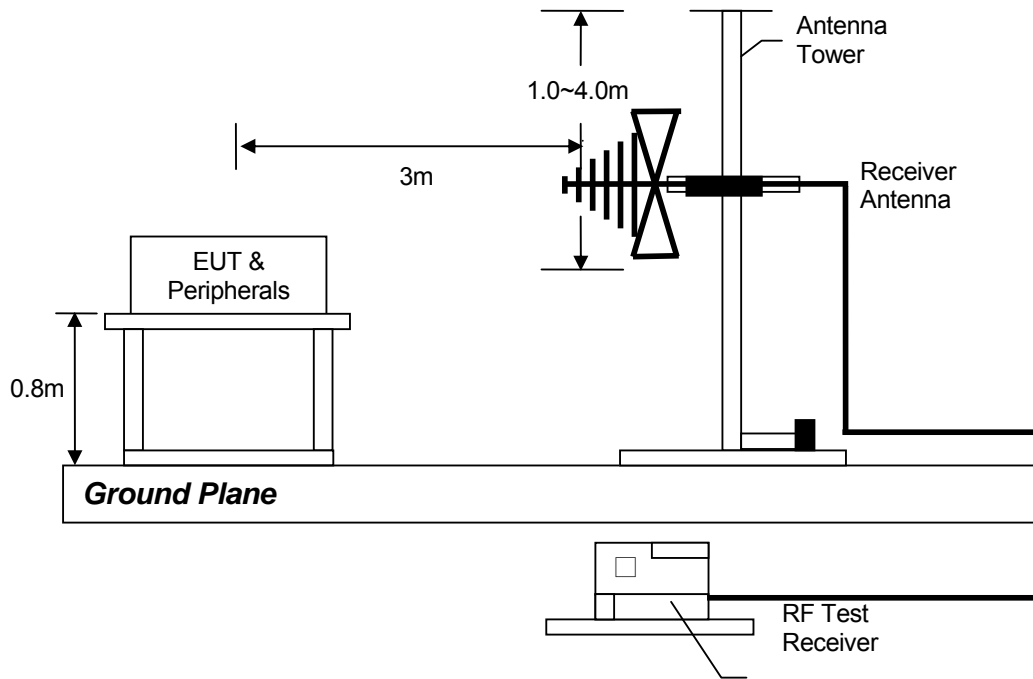

Test setup of radiated emissions upto 1GHz

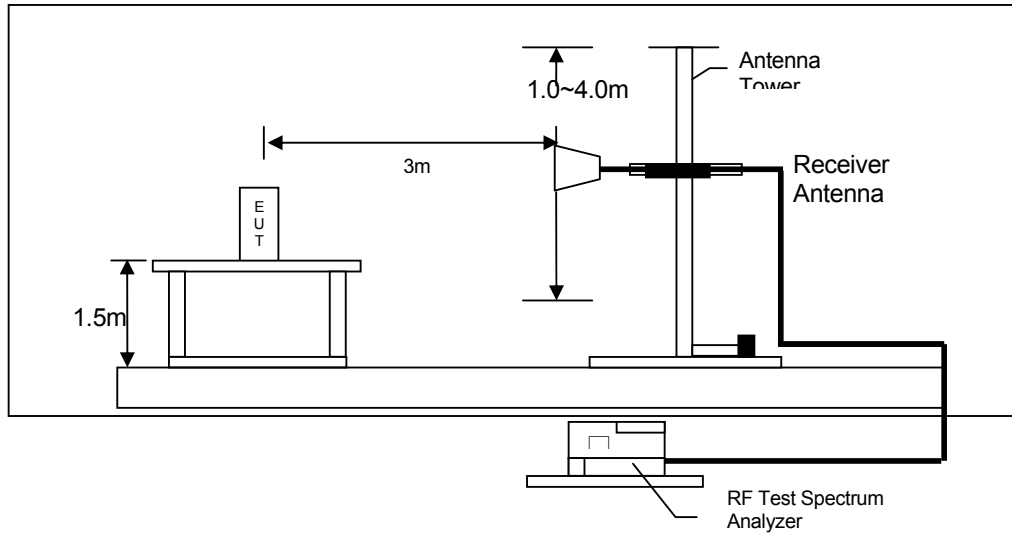

Test setup of radiated emissions above 1GHz

8.4.2 Conducted Emission Test Procedures

For tabletop equipment, the EUT along with its peripherals were placed on a 1.0m(W)×1.5m(L) and 0.8m in height wooden table. For floor-standing equipment, the EUT and all cables were insulated, if required, from the ground plane by up to 12 mm of insulating material. The EUT was adjusted to maintain a 0.4 meter space from a vertical reference plane. The EUT was connected to power mains through a line impedance stabilization network (LISN), which provided 50 ohm coupling impedance for measuring instrument and the chassis ground was bounded to the horizontal ground plane of shielded room. The excess power cable between the EUT and the LISN was bundled.

All connecting cables of EUT and peripherals were moved to find the maximum emission.

8.4.3 Conducted Emission Test Setup

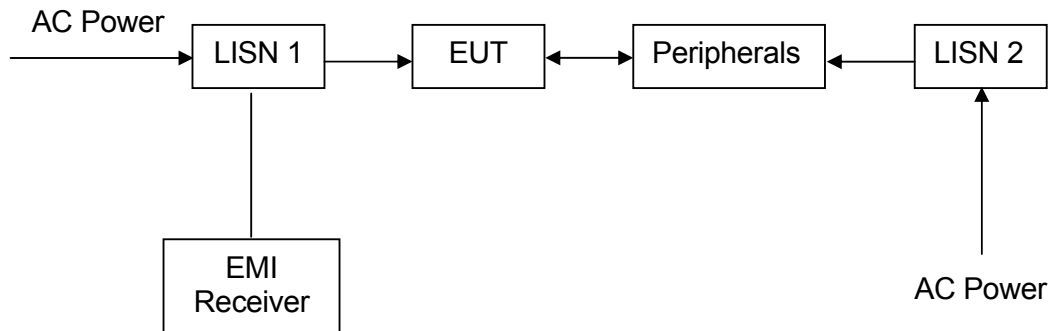

8.5 Occupied Bandwidth

Occupied Bandwidth Results: (Bluetooth 4.0 BLE)

Bluetooth	Occupied Bandwidth (MHz)
Low Channel: 2402	1.36
Middle Channel: 2440	1.56
High Channel: 2480	1.16

The worst case is shown as below:

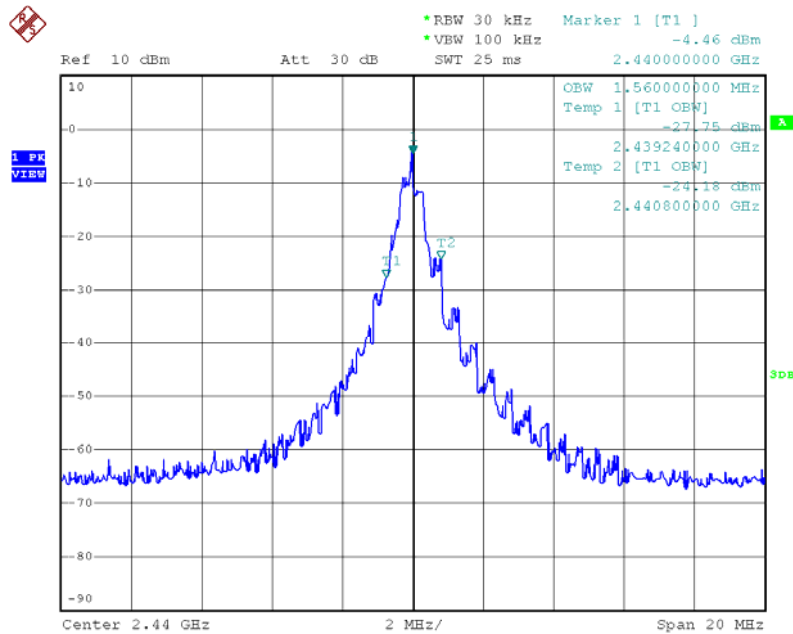



Valued Quality. Delivered.

9.0 Confidentiality Request

For electronic filing, a preliminary copy of the confidentiality request is saved with filename: request.pdf.

10.0 Equipment List

1) Radiated Emissions Test

Equipment	EMI Test Receiver	Log Periodic Antenna	Biconical Antenna
Registration No.	EW-2500	EW-0446	EW-0571
Manufacturer	R&S	EMCO	EMCO
Model No.	ESCI	3146	3104C
Calibration Date	Nov. 06, 2014	Nov. 10, 2014	Nov. 01, 2013
Calibration Due Date	Nov. 06, 2015	May 10, 2016	May 01, 2015

Equipment	Spectrum Analyzer	Double Ridged Guide Antenna
Registration No.	EW-2253	EW-1133
Manufacturer	R&S	EMCO
Model No.	FSP40	3115
Calibration Date	May 08, 2014	Apr. 30, 2014
Calibration Due Date	May 08, 2015	Oct. 30, 2015

2) Bandedge Measurement

Equipment	Spectrum Analyzer
Registration No.	EW-2249
Manufacturer	R&S
Model No.	FSP30
Calibration Date	Nov. 19, 2014
Calibration Due Date	Nov. 19, 2015

END OF TEST REPORT