

# CORNING

## Small Cell Radio Node - SCRN-520 Hardware Installation Guide

DOC-SCRN-520-HIG\_i3  
Issue 3

Related Literature | Search [www.Corning.com/opcomm](http://www.Corning.com/opcomm). Click Required Resources.

### Revision History

Issue	Date	Summary of Changes
1	17FEB21	Initial release for SCRN-520 Small Cell Radio Node.
2	25FEB21	Documents changes made to the SCRN-520.
3 Draft	11MAR21	Updated graphics.



# Table of Contents

- FCC Statement ..... 3
- Safety Precautions ..... 3
- Other Cautions ..... 4
- 1. .... About this Manual 5
- 2. .... Product Overview 5
- 3. .... Radio Node Model 6
  - 3.1 ..... SCRN-520 Views 7
- 4. .... Connectors, SFP+ and Micro-USB Ports, and Status LED 8
  - 4.1 ..... Phoenix Power Cable Ports 8
  - 4.2 ..... SFP+ Transceiver Port 8
  - 4.3 ..... Micro-USB Port 8
  - 4.4 ..... Status LED 8
- 5. .... System Specifications 9
- 6. .... Compliance 10
- 7. .... Mounting the SCRN-520 10
  - 7.1 ..... Ceiling Installation of the SCRN-520 11
  - 7.2 ..... Wall Installation of the SCRN-520 12
- 8. .... Cabling Guidelines 14
- 9. .... Completing the Installation 14
- 10. .... Detaching the SCRN-520 from the Mounting Brackets 14
- 11. .... SCRN-520 LED Boot Sequence 15
- 12. .... SCRN-520 LED Management 16
  - 12.1 ..... Disabling the LED display 16
  - 12.2 ..... Re-Enabling the LED Display 17
- 13. .... SFP+ LED Indications 17
- 14. .... Corning Documentation Set 17

# FCC Statement

**Caution:** Any changes or modifications to this device not explicitly approved by manufacturer could void your authority to operate this equipment.

**RF Exposure warning statement:**

This equipment complies with FCC radiation exposure limits set forth for an uncontrolled environment. This equipment should be installed and operated with minimum 42 cm between the radiator and your body. This transmitter must not be collocated or operating in conjunction with any other antenna or transmitter unless authorized to do so by the FCC.

This device can be expected to comply with part 15 of the FCC Rules provided it is assembled in exact accordance with the instructions provided with this kit. Operation is subject to the following conditions: (1) This device may not cause harmful interference, and (2) this device must accept any interference received including interference that may cause undesired operation.

**NOTE:** This equipment has been tested and found to comply with the limits for a Class A digital device, pursuant to part 15 of the FCC Rules. These limits are designed to provide reasonable protection against harmful interference when the equipment is operated in a commercial environment. This equipment generates, uses, and can radiate radio frequency energy and, if not installed and used in accordance with the instruction manual, may cause harmful interference to radio communications. Operation of this equipment in a residential area is likely to cause harmful interference in which case the user will be required to correct the interference at his own expense.

## Safety Precautions

Corning strongly recommends reviewing and adhering to the following cautions and notices before installing and operating the SCR-N-520.

	<b>WARNING:</b> This warning symbolizes danger that may cause severe injury or death. Before installing or servicing equipment ensure that you are aware of all hazards involved with electrical circuitry and become familiar with applicable safety standards and national and local electrical codes and any other relevant standards.
---	---

	<b>WARNING:</b> Do not locate outdoor antennas near overhead power lines or other power circuits that might come into contact with the antennas and their wiring. Contacting such circuits during installation can cause severe injury or death. Refer to national and local electrical codes and any other relevant standards for more safety information.
---	---

	<b>WARNING:</b> Ensure that you install a suitable lightning arrestor for outside antenna installations.
---	--

	<b>WARNING:</b> Do not use or service any equipment with outdoor connections during electrical storms due to risk of lightning.
---	---

	<b>WARNING:</b> All electrical equipment must be properly grounded. Refer to national and local electrical codes and any other relevant standards for electrical grounding information.
---	---

	<b>WARNING:</b> If an external antenna starts to fall during installation, for models that are designed for external antennas, let it drop as it may contact a power line or other electrical circuitry that might cause severe injury or death.
---	--

	<b>NOTE:</b> For Professionals & Trained Installers 1. The device is designed for wall mount or ceiling mount applications only in an enterprise environment. 2. Installers are required to maintain RF safety distances of 42 cm during the course of installation process. 3. Wall installation should be avoided, if a minimum safety distance of 42 cm cannot be maintained.
---	---

## Other Cautions

	<b>CAUTION:</b> ESD can damage the SCR-520 and internal components. Ensure that the SCR-520 and associated antenna equipment is installed and serviced according to national and local ESD standards.
---	---

	<b>CAUTION:</b> Ensure that the antenna cable conforms to the environment in which it is used.
---	--

	<b>CAUTION:</b> Do not open the SCR-520 casing. E-RAN wireless system equipment must only be serviced by Corning-accredited personnel. Opening the SCR-520 casing voids the warranty.
--	---

# 1. About this Manual

The Corning SCRN-520 small cell radio node is an integrated 5G new radio (NR) mmWave radio node that is part of the Corning enterprise radio access network (E-RAN). The scalable SCRN-520 radio node and the enterprise radio access network (E-RAN) simplify the complexity of radio management and mobility, and provide operators with a single interface to aggregate and manage a large network of radio nodes. This guide provides the system specifications of the SCRN-520. It includes detailed hardware installation instructions, the boot sequence, and expected LED behavior both during the boot-up and under normal operating conditions.

**NOTE:** *The SCRN-520 small cell radio node is commonly referred to as “radio node” in the rest of this document.*

**NOTE:** *The 5G New Radio (NR) is a new radio access technology developed by 3GPP for fifth generation (5G) mobile networks.*

The primary audience for this guide includes network planners, system administrators and installation personnel. It assumes you have knowledge about networking principles, networking configuration, site preparation, powering, and experience in hardware installation and maintenance.

# 2. Product Overview

The SCRN-520 is a 5G mmWave Time Division Duplexing (TDD) radio node that supports 2 x 2 MIMO small cell operation on NR band n261, enabling high user capacity and high data rates for the coverage footprint. The radio node connects to a Corning centralized unit (CU). It uses certificate-based authentication with the Corning CU. Radio Nodes are managed by the Corning centralized units installed in the enterprise or in a centralized location such as a data center.

The SCRN-520 fronthaul network can be deployed using approved 10 Gb fiber optic cables. The SCRN-520 receives 48 VDC power from a Corning PSU6 DC Power Supply Unit or equivalent. There is no management or console port on the SCRN-520, and the radio node is physically locked to prevent theft. The SCRN-520 is passively convection-cooled, and its antennas are built-in. Each SCRN-520 comes with a ceiling-mount bracket attached for installing directly to a flat surface, as well as a second multi-angle (0, 15, 30, and 45 degree) wall-mount bracket loose in the box.

The SCRN-520 uses on-chip Trusted Platform Module (TPM) functions to implement secure boot, and to establish certificate-based IPsec tunnels to the centralized unit. It includes a PTP client to achieve frequency and phase synchronization with other mmWave radio nodes and base stations.

The E-RAN element management system includes configuration, fault and performance monitoring, and security functions.

[Figure 1](#) shows the architecture of the 4G and 5G E-RAN network.

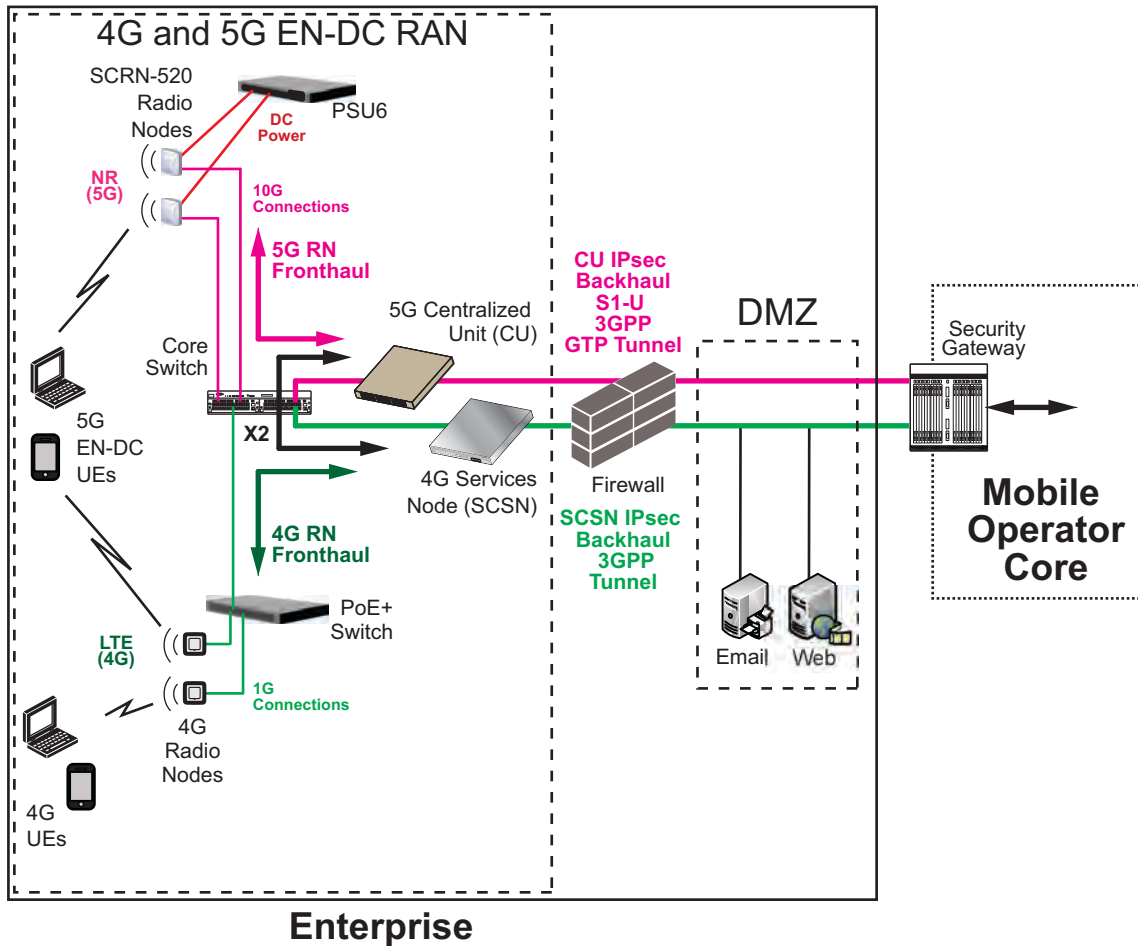

Figure 1 4G and 5G E-RAN Architecture

### 3. Radio Node Model

Table 1 includes the SCRN-520 configuration.

Table 1 Radio Node Configuration

Radio Node Model	Description	Antenna Type
SCRN-520-28	28 GHz band n261 mmWave RN with 8 x 8 dual-polarization antenna array	Internal

### 3.1 SCRN-520 Views

Figure 2 and Figure 3 display views of the SCRN-520.



**Figure 2** SCRN-520 Cover



**Figure 3** SCRN-520 With Ceiling-Mount Bracket

## 4. Connectors, SFP+ and Micro-USB Ports, and Status LED

The SCRN-520 has the following connectors and a small form-factor pluggable SFP+ port, as shown in [Figure 4](#).

### 4.1 Phoenix Power Cable Ports

The SCRN-520 has a 48 VDC power connector for delivering power from a Corning PSU6 DC Power Supply Unit or equivalent to the radio node. Plug the Phoenix power connector from the power source cable into the power connector.

### 4.2 SFP+ Transceiver Port

The SFP+ Transceiver Port accommodates a compact enhanced small form-factor pluggable (SFP+) network interface module. The hot-pluggable SFP+ supplied with this SCRN-520, must be installed in the Transceiver Port. The LC connector, terminated end, of the fiber pair of an ActiFi cable (or other approved fiber cable) is then connected to the SFP+ LC Ports to provide fronthaul transport network access to the radio node. Refer to [Section 13. SFP+ LED Indications](#) for more information.

### 4.3 Micro-USB Port

The Micro-USB port is completely disabled and is not available for general use.

### 4.4 Status LED

The STA (status) RGB tri-color LED indicates the state of the SCRN-520, with boot, normal, disabled, fault, and SCRN-520 indications. When the radio node initially boots, the LED cycles through a number of colors and flashing behaviors until the radio node is fully operational. [Section 11. SCRN-520 LED Boot Sequence](#) describes the STA LED indications.



**Figure 4** SCRN-520 Connectors and Status LED



## 5. System Specifications

The SCRN-520 has the chassis measurements, power requirements, and environmental requirements, and complies with the standards listed in [Table 2](#). Refer to the feature guide for your centralized unit software release for release-specific features and specifications.

**Table 2 SCRN-520 Specifications**

<b>Operating Band</b>	2 x 2 MIMO operation on 28-GHz NR band n261 (27.5–28.35 GHz)
<b>Channel Size</b>	Component Carrier (CC) bandwidth: 100 MHz
<b>Antenna Type</b>	8 x 8 dual-polarization internal antenna array
<b>Antenna Power</b>	43 dBm EIRP @ 64QAM Beamforming scan range: +/- 60 degrees
<b>RF Management</b>	Beam Management with auto-assignment of physical cell identities (PCIs)
<b>QoS Features</b>	Non-GBR bearer support per UE
<b>Dimensions</b>	279.4 x 279.4 x 80.3 mm (11.0 x 11.0 x 3.16 in)
<b>Weight</b>	4.5 kg (9.9 lbs)
<b>Input Power</b>	36-60 VDC, 2A
<b>Power Consumption</b>	70 W
<b>Ingress Protection</b>	Ingress protection rating: IP30
<b>Performance</b>	4CC; up to 64 active users
<b>Peak Tx Rate</b>	1.8 Gbps DL, 60 Mbps UL (DL:UL slot ratio of 4:1) @ 64QAM with 4CC DL, 1CC UL
<b>Licensed Tx Power</b>	Equivalent isotropically radiated power (EIRP): 43 dBm
<b>Ethernet Interface</b>	SFP+ supports 10 GbE (Gigabit Ethernet)
<b>LEDs</b>	1 tricolor (RGB) LED to indicate power and status, 2 SFP LEDs to indicate Link/Activity status
<b>Synchronization</b>	IEEE 1588v2-based (PTP) synchronization with an external PTP grandmaster clock
<b>Mounting</b>	Wall or Ceiling, brackets included Brackets support four wall-mount tilting options: 0°, 15°, 30°, and 45° tilt
<b>Cooling Method</b>	Passive cooling
<b>Security</b>	Secure boot and secure key storage using Trusted Platform Module (TPM) functions IPSec tunneling to NR CU (Centralized Unit) X.509 certificate-based authentication
<b>Environmental Requirements</b>	Operating temperature range: 0° to 45°C (32° to 113°F) Non-operating temperature range: -40° to +70°C (-40° to 158°F) Relative humidity: Operating and storage: 0% RH to 90% RH non-condensing
<b>MTBF</b>	1,363,791 hours at +40°C (104°F)

## 6. Compliance

The SCRN-520 complies with the standards listed in [Table 3](#).

**Table 3 Radio Node Compliance**

<b>Safety</b>	UL-62368-1 2nd Edition FCC Compliant - Part 15 (Class A), Part 30 MPE: FCC 47 CFR 1.1310 FCC 47 CFR 1.1307(b)
---------------	--

## 7. Mounting the SCRN-520

Radio Nodes can be installed on walls and below ceilings with the factory-provided brackets. When mounting a radio node on a wall, position the cooling fins vertically. The factory-provided wall-mount bracket can tilt the SCRN-520 down at the following angles: 0°, 15°, 30° and 45°. [Figure 5](#) shows SCRN-520 downtilt options.

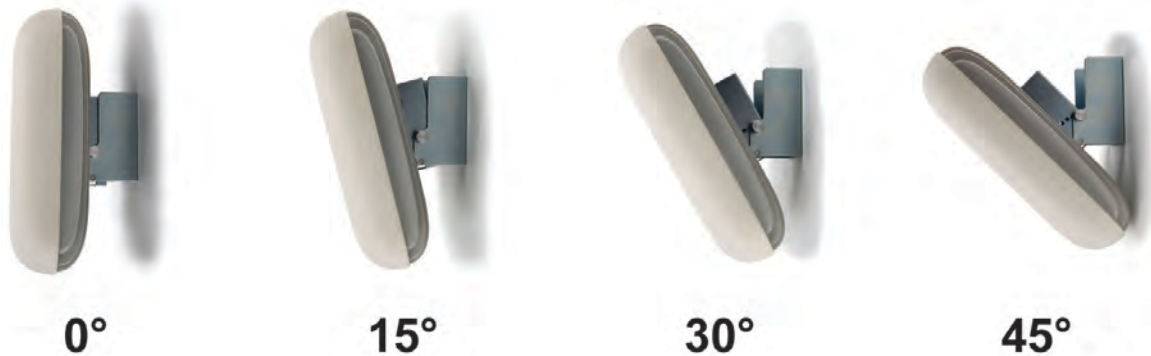

**Figure 5 Mounting Bracket Downtilt Options**

**NOTE:** Always consult and follow local codes for mounting and wiring Corning equipment.

When possible, locate downward-radiating radio node units at least 0.5 meters (20 inches) from external walls and minimum height of 2.44 meters (8 feet). This distance maximizes indoor coverage and minimizes RF leakage outside the building. When mounting near a wall or other obstruction, orient the mounting bracket so that the top of the radio node faces towards the coverage area and faces away from the wall.

## 7.1 Ceiling Installation of the SCRN-520

As shown in [Figure 3](#), the SCRN-520 comes with the ceiling-mount bracket attached. This bracket is held to the radio node mounting side with four shoulder screws and a captive securing screw, and is non-tilting. The shoulder screws should not need to be adjusted but if they do, loosen them slightly to be able to slide the ceiling-mount bracket on and off of the radio node when the captive securing screw has been loosened. [Figure 6](#) shows the captive securing screw and four security screw locations.

**NOTE:** *The security screws should not need to be adjusted but if they do, loosen them slightly to be able to slide the ceiling-mount bracket on and off.*

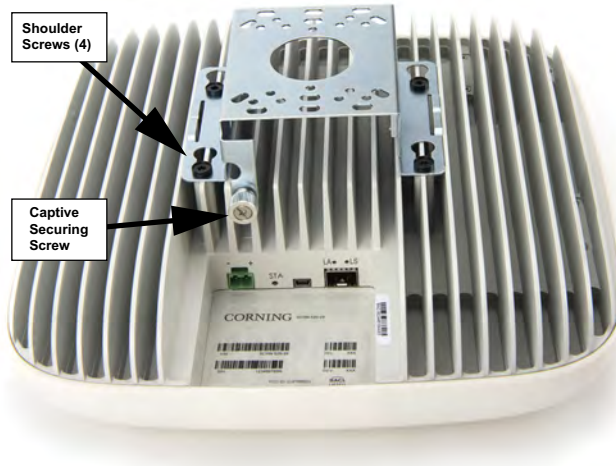

**Figure 6** Ceiling-Mount Bracket Screw Locations

**Step 1** Loosen the captive securing screw on the ceiling-mount bracket.

**Step 2** Slide the ceiling-mount bracket toward the captive securing screw to remove it from the radio node base.

**NOTE:** *The shoulder screws should not need to be adjusted but if they do, loosen them slightly to be able to slide the ceiling-mount bracket on and off.*

**Step 3** Secure the ceiling tethering system. Make sure that it can support the weight of the radio node and the ceiling-mount bracket.

**NOTE:** *Corning recommends that you use a customer-supplied projector mount when hanging the radio node from a dropped T-bar ceiling.*

**Step 4** Secure the ceiling-mount bracket to ceiling tethering system.

**Step 5** Slide the radio node back onto the bracket and gently tighten the securing screw.

[Figure 7](#) shows a radio node and the ceiling-mount bracket as the assembly can be mounted to a ceiling tethering system.



**Figure 7 Radio Node with Ceiling-Mount Bracket**

## 7.2 Wall Installation of the SCRN-520

The SCRN-520 comes with the ceiling-mount bracket attached, and has the multi-angle wall-mount bracket loose in the box. [Figure 8](#) shows the radio node wall-mount bracket.



**Figure 8 Radio Node Wall-Mount Bracket**

When using the multi-angle wall-mount bracket, it is not necessary to remove the ceiling-mount bracket from the radio node; the wall-mount bracket attaches to the wall, and then it attaches to the ceiling-mount bracket-and-radio node assembly. [Figure 9](#) shows how the similar radio node wall-mount bracket attaches to the ceiling-mount bracket.



**Figure 9 Wall-Mount Bracket Attached to the Ceiling-Mount Bracket**

**Step 1** Using a spirit level, use the wall-mount bracket as a template to mark securing hole locations.

**Step 2** If required, install sheet rock plugs.

**Step 3** Attach the wall-mount bracket to the wall. [Figure 8](#) shows the radio node wall-mount bracket.

**Step 4** Seat the ceiling-mount bracket on wall-mount bracket:

- First, attach the ceiling mount bracket to Radio, then slide this subassembly into the wall bracket.
- Then, set the radio node to the required tilt, and tighten the wall-mount bracket captive securing screw to lock the radio node tilt angle.

**NOTE:** *Put pressure on the radio node when tightening the captive securing screw.* [Figure 10](#) shows how to attach the wall-mount bracket to the ceiling-mount bracket.

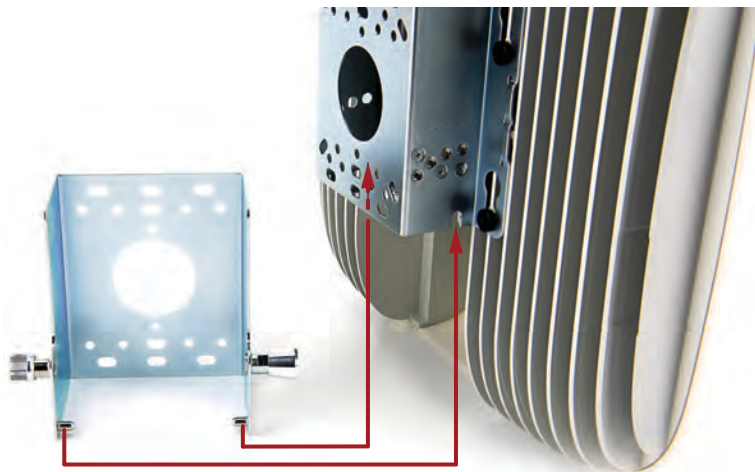

**Figure 10 Attaching the SCR N-520 with Ceiling-Mount Bracket to the Wall-Mount Bracket**

**Step 5** Make sure that both of the captive securing screws are tightened.

## 8. Cabling Guidelines

Incorrectly cabling the SCRN-520 can result in crushed cables and loss of communications to the radio node. Follow these guidelines when cabling the SCRN-520:

- Make sure that the cabling is properly routed and dressed.
- When mounting the radio node vertically, orient the bracket so that the bracket keyholes have the wide side up as shown in [Figure 3](#).
- Make sure that the radio node is fully secured to the mounting brackets so that it locks into place. A correctly-installed cable should at no time during installation impede inserting the radio node into the mounting brackets.

## 9. Completing the Installation

**Step 1** Make sure that the captive securing screws are tightened. The radio node is now anchored.

**Step 2** When it receives power, the radio node boots up and attempts to connect to the centralized unit.

## 10. Detaching the SCRN-520 from the Mounting Brackets

**Step 1** Loosen the captive securing screw on the left side of wall mount bracket.

**Step 2** Pull the plunger pin on the right side of the wall mount bracket and by pulling up take out the radio node from the wall mount bracket.

**Step 3** Detach the cables from the cable brackets and cable connectors.

**Step 4** Loosen the captive securing screw and slide out the bracket from the radio node.

## 11. SCRN-520 LED Boot Sequence

The radio node state machine is sequential and progresses in the following order:

**State 0 -> State 1 -> State 2 -> State 3 -> State 4 -> State 5 -> State 6**

A normal boot sequence transitions through all these states sequentially and the LED state transitions accordingly. If the radio node fails to transition to the next state, the system restarts the boot sequence, starting with State 0. You can determine the progress during the booting stages by observing the LED color transitions. When the boot sequence completes, all devices are reachable.

On failure, the LED state display the state that encountered the failure. [Table 4](#) shows the SCRN-520 boot sequence and corresponding LED behavior.

**Table 4 SCRN-520 LED Boot Sequence**

State	LED Color	Description	Possible Failures and Actions
0. Power On/ Reset	Flashing Green	This is the initial state on startup. The radio node bootup is controlled by firmware in this state.	This state should be very short lived and should transition to the next state immediately.
1. Software Initialization	Flashing Green	The firmware has loaded and transferred control to the bootloader. Additional hardware initialization and validation are performed during this state. This state concludes with a lamp test, cycling through all LED colors.	This state should be very short lived and should transition to the next state immediately.  A radio node should not stay in this state indefinitely.  <b>Note:</b> Flashing Green is also used to indicate a radio node that has been administratively disabled. This can be determined from the CLI.
2. DHCP	Solid Red	The radio node starts by sending out a DHCP Request.  The radio node moves to the next state (State 3) upon receiving a DHCP response and an IP Address.	No DHCP Response, IP Address not allocated.  Check cabling, DHCP Server configuration.
3. Join	Solid Blue	The radio node has an IP Address and sends a UDP Join request to the Serving centralized unit.  The radio node moves to the next state (State 4) upon getting a JOIN GRANT from the centralized unit.	No IP reachability to the centralized unit.  Check IP network between radio node and centralized unit for routing issues.
4. TFTP	Flashing Blue	The radio node proceeds next to download the operating system image from the centralized unit.  The radio node moves to the next state (State 5) after the image has been downloaded.	Failure to download TFTP image.  Check firewall between radio node and centralized unit.



**Table 4 SCRN-520 LED Boot Sequence (Continued)**

State	LED Color	Description	Possible Failures and Actions
5. Operating System Booting	Solid Green for a few seconds, off for about 30 seconds, then Solid Green	The radio node loads the operating system and starts the default platform applications. The radio node moves to the next state (State 6) when it establishes connectivity with the centralized unit.	Failure to start the operating system. This normally points to a software/build issue. Please contact Corning support.
6. Running	Solid Green	The operating system is running. The radio node continues the startup sequence, but is now controlled by the centralized unit.	The operating system is up and running on the radio node. Any subsequent state transitions can now be tracked from events and logs on the centralized unit.

## 12. SCRN-520 LED Management

The LED display is active by default, but can be deactivated in light-sensitive environments as needed. Even when the display is disabled, the LED will be lighted during the following conditions:

- while the radio node is booting
- if the radio node or cell is in fault state

Table 5 lists the default LED behavior of the radio node.

**Table 5 SCRN-520 LED Behavior**

LED	Status	Flash Rate
Green: slow flashing	The radio node or radio is administratively disabled	Approximately 1/2 second on, 1 1/2 sec. off
Green: fast flashing	Syncing	Approximately 1.4 second on/off cycle
Green: solid	Operational	
Red: solid	Fault	
Blue: fast flashing	Locate radio node enabled (Note)	Approximately 1 second on/off cycle
Off	Powered off or LED disabled	

**Note:** Refer to the *Corning SCOS Administrator Guide* for information about the locate radio node feature.

### 12.1 Disabling the LED display

**Step 1** From the CLI Configuration Mode, issue the `Set System RadioNode LED DefaultMode Dark` command to disable the LED display:

```
%set System RadioNode LED DefaultMode Dark
```

**Step 2** Issue the `show System RadioNode LED` command to verify the configuration:

```
%show System RadioNode LED
DefaultMode Dark;
```



## 12.2 Re-Enabling the LED Display

**Step 1** From the CLI Configuration Mode, issue the `set System RadioNode LED DefaultMode Standard` command to re-enable the LED display:

```
%set System RadioNode LED DefaultMode Standard
```

**Step 2** Issue the `show System RadioNode LED` command to verify the configuration:

```
%show System RadioNode LED
DefaultMode Standard;
```

## 13. SFP+ LED Indications

The enhanced small form-factor pluggable has a green Link Status Indicator LED, and an unused amber LED. The Link Status Indicator LED has the following operational modes:

- Off                                No Link (disconnected)
- Solid Green                        10 Gbps link has been established

## 14. Corning Documentation Set

The Corning documentation can be downloaded from the customer support portal (the “Corning One Community”) at <https://onesupport.corning.com>. This site requires a login which is available to individuals who have attended Corning Small Cell training in the past two years. Email [onesupport@corning.com](mailto:onesupport@corning.com) to request a login if you meet these criteria.