

DATE: 05 February 2008

**I.T.L. (PRODUCT TESTING) LTD.
FCC EMC/Radio Test Report
for
MobileAccess Networks**

Equipment under test:

**WLAN Module With WCE (WiFi Coverage Extender) for
DAS With Four Cisco 1242 Access Points**

860M With WCE*

* See customer's declaration on page 7.

Written by: 
D. Shidlow, Documentation

Approved by: 
E. Pitt, Test Engineer

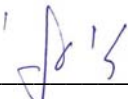
Approved by: 
I. Raz, EMC Laboratory Manager

This report must not be reproduced, except in full, without the written permission of I.T.L. (Product Testing) Ltd.

This report relates only to items tested.



Measurement/Technical Report for MobileAccess Networks

WLAN Module With WCE (WiFi Coverage Extender) for
DAS With Four Cisco 1242 Access Points

860M With WCE

FCC ID: OJFMA860WCE

05 February 2008

This report concerns: Original Grant Class II change

Class B verification Class A verification Class I change

Equipment type: Direct Sequence Spread Spectrum Transmitter

Request Issue of Grant:

Immediately upon completion of review

Limits used:

CISPR 22

Part 15

Measurement procedure used is ANSI C63.4-2003.

Application for Certification

prepared by:

Ishaishou Raz

ITL (Product Testing) Ltd.

Kfar Bin Nun

D.N. Shimshon 99780

Israel

e-mail Sraz@itl.co.il

Applicant for this device:

(different from "prepared by")

Steve Blum

Mobile Access Networks

8391 Old Courthouse Rd., Suite #300

Vienna, VA. 22182

U.S.A.

Tel: +1-541-758-2880

Fax: +1-703-848-0260

e-mail: sblum@mobileaccess.com

TABLE OF CONTENTS

1.	GENERAL INFORMATION-----	6
1.1	Administrative Information.....	6
1.2	List of Accreditations	8
1.3	Product Description	9
1.4	Test Methodology.....	9
1.5	Test Facility	9
1.6	Measurement Uncertainty	9
2.	SYSTEM TEST CONFIGURATION-----	10
2.1	Justification.....	10
2.2	EUT Exercise Software	10
2.3	Special Accessories	10
2.4	Equipment Modifications	10
2.5	Configuration of Tested System.....	11
3.	THEORY OF OPERATION -----	12
3.1	Theory of Operation	12
4.	SPURIOUS RADIATED EMISSION IN THE RESTRICTED BAND, BELOW 1 GHZ	
	2.4GHZ TRANSMITTER 802.11B/G+802.11A SIGNALS -----	14
4.1	Test Specification	14
4.2	Test Procedure.....	14
4.3	Test Data	15
4.4	Test Instrumentation Used, Radiated Measurements	20
4.5	Field Strength Calculation	21
5.	SPURIOUS RADIATED EMISSION IN THE RESTRICTED BAND, ABOVE 1 GHZ	
	2.4GHZ TRANSMITTER 802.11 B/G + 802.11A SIGNALS-----	22
5.1	Radiated Emission Above 1 GHz.....	22
5.2	Test Data	23
5.3	Test Instrumentation Used, Radiated Measurements Above 1 GHz.....	30
6.	26 DB BANDWIDTH 2.4 GHZ TRANSMITTER 802.11 B/G + 802.11A SIGNALS -----	31
6.1	Test procedure	31
6.2	Test Equipment Used.....	38
7.	MAXIMUM TRANSMITTED PEAK POWER OUTPUT 2.4 GHZ TRANSMITTER	
	802.11 B/G + 802.11A SIGNALS -----	39
7.1	Test procedure	39
7.2	Results table.....	46
7.3	Test Equipment Used.....	47
8.	PEAK POWER OUTPUT OUT OF 2400-2483.5 MHZ BAND 2.4 GHZ	
	TRANSMITTER 802.11 B/G +A SIGNALS -----	48
8.1	Test procedure	48
8.2	Results table.....	91
8.3	Test Equipment Used.....	92
9.	6 DB MINIMUM BANDWIDTH 2.4GHZ TRANSMITTER 802.11B/G + 802.11A	
	SIGNALS -----	93
9.1	Test procedure	93
9.2	Results table.....	100
9.3	Test Equipment Used.....	101
10.	BAND EDGE SPECTRUM 2.4GHZ TRANSMITTER 802.11B/G + 802.11A SIGNALS	102
10.1	Test procedure	102
10.2	Results table.....	107
10.3	Test Equipment Used.....	108

11.	TRANSMITTED POWER DENSITY 2.4GHZ TRANSMITTER 802.11 B/G +A SIGNALS	109
11.1	Test procedure	109
11.2	Results table.....	116
11.3	Test Equipment Used.....	117
12.	ANTENNA GAIN 2.4GHZ TRANSMITTER 802.11 B/G +A SIGNALS	118
13.	R.F EXPOSURE/SAFETY 2.4GHZ TRANSMITTER 802.11 B/G +A SIGNALS	119
14.	RADIATED EMISSION PER FCC PART 15 SUB-PART B TEST DATA 802.11 B/G +802.11A SIGNALS	120
14.1	Test Specification	120
14.2	Test Procedure.....	120
14.3	Test Data	121
14.4	Test Instrumentation Used, Radiated Measurements	126
14.5	Field Strength Calculation	127
15.	SPURIOUS RADIATED EMISSION IN THE RESTRICTED BAND, BELOW 1 GHZ 2.4GHZ TRANSMITTER 802.11B/G + 802.11A + CELL + PCS SIGNALS	128
15.1	Test Specification	128
15.2	Test Procedure.....	128
15.3	Test Data	129
15.4	Test Instrumentation Used, Radiated Measurements	134
15.5	Field Strength Calculation	135
16.	SPURIOUS RADIATED EMISSION IN THE RESTRICTED BAND, ABOVE 1 GHZ 2.4GHZ TRANSMITTER 802.11B/G + 802.11A + CELL + PCS SIGNALS	136
16.1	Radiated Emission Above 1 GHz.....	136
16.2	Test Data	137
16.3	Test Instrumentation Used, Radiated Measurements Above 1 GHz.....	144
17.	26 DB BANDWIDTH 2.4 GHZ TRANSMITTER 802.11B/G + 802.11A + CELL + PCS SIGNALS	145
17.1	Test procedure	145
17.2	Test Equipment Used.....	152
18.	MAXIMUM TRANSMITTED PEAK POWER OUTPUT 2.4 GHZ TRANSMITTER 802.11B/G + 802.11A + CELL + PCS SIGNALS	153
18.1	Test procedure	153
18.2	Results table.....	160
18.3	Test Equipment Used.....	161
19.	PEAK POWER OUTPUT OUT OF 2400-2483.5 MHZ BAND 2.4 GHZ TRANSMITTER 802.11B/G + 802.11A + CELL + PCS SIGNALS	162
19.1	Test procedure	162
19.2	Results table.....	205
19.3	Test Equipment Used.....	206
20.	6 DB MINIMUM BANDWIDTH 2.4GHZ TRANSMITTER 802.11B/G + 802.11A + CELL + PCS SIGNALS	207
20.1	Test procedure	207
20.2	Results table.....	214
20.3	Test Equipment Used.....	215
21.	BAND EDGE SPECTRUM 2.4GHZ TRANSMITTER 802.11B/G + 802.11A + CELL + PCS SIGNALS	216
21.1	Test procedure	216
21.2	Results table.....	221
21.3	Test Equipment Used.....	222
22.	TRANSMITTED POWER DENSITY 2.4GHZ TRANSMITTER 802.11B/G + 802.11A + CELL + PCS SIGNALS	223
22.1	Test procedure	223
22.2	Results table.....	230
22.3	Test Equipment Used.....	231

23.	ANTENNA GAIN 2.4GHZ TRANSMITTER 802.11B/G + 802.11A + CELL + PCS SIGNALS	232
24.	R.F EXPOSURE/SAFETY 2.4GHZ TRANSMITTER 802.11B/G + 802.11A + CELL + PCS SIGNALS	233
25.	RADIATED EMISSION PER FCC PART 15 SUB-PART B TEST DATA 802.11B/G + 802.11A + CELL + PCS SIGNALS	234
	25.1 Test Specification	234
	25.2 Test Procedure	234
	25.3 Test Data	235
	25.4 Test Instrumentation Used, Radiated Measurements	240
	25.5 Field Strength Calculation	241
26.	INTERMODULATION TESTS	242
	26.1 Test procedure	242
	26.2 Test Equipment Used.....	250
27.	APPENDIX A - CORRECTION FACTORS	251
	27.1 Correction factors for CABLE	251
	27.2 Correction factors for CABLE	252
	27.3 Correction factors for CABLE	253
	27.4 Correction factors for CABLE	254
	27.5 Correction factors for LOG PERIODIC ANTENNA	255
	27.6 Correction factors for LOG PERIODIC ANTENNA	256
	27.7 Correction factors for BICONICAL ANTENNA.....	257
	27.8 Correction factors for BICONICAL ANTENNA.....	258
	27.9 Correction factors for Double-Ridged Waveguide Horn	259
	27.10 Correction factors for Horn Antenna	260
	27.11 Correction factors for Horn Antenna	261
	27.12 Correction factors for ACTIVE LOOP ANTENNA	262

1. General Information

1.1 Administrative Information

Manufacturer: MobileAccess Networks

Manufacturer's Address: 8391 Old Courthouse Rd.
Suite #300
Vienna, VA 22182
U.S.A.
Tel: +1-541-758-2880
Fax: +1-703-848-0260

Manufacturer's Representative: Steve Blum

Equipment Under Test (E.U.T): WLAN Module With WCE (WiFi Coverage Extender) for DAS With Four Cisco 1242 Access Points

Equipment Model No.: 860M With WCE (See customer's declaration on following page).

Equipment Serial No.: 1. 860M: 73903D
2. WCE: 739038

Date of Receipt of E.U.T: 27.01.08

Start of Test: 27.01.08

End of Test: 04.02.08

Test Laboratory Location: I.T.L (Product Testing) Ltd.
Kfar Bin Nun,
ISRAEL 99780

Test Specifications: See Section 2

15/11/2007

DECLARATION

I HEREBY DECLARE THAT THE FOLLOWING PRODUCT:

860M

IS IDENTICAL ELECTRONICALLY, PHYSICALLY, AND
MECHANICALLY TO:

MA-860

Please relate to them all (from an EMC point of view) as the
same product.

Thank you,

Signature:  _____

Shai Rachamim
Verification Engineer
MobileAccess Networks
Ofek One Center, Bldg.2
Northern Industrial Zone
Lod, Israel 71293

E-mail: ShaiR@MobileAccess.com
Wired: +972-8-9183804
Unwired: +972-52-6994548

1.2 List of Accreditations

The EMC laboratory of I.T.L. is accredited by the following bodies:

1. The American Association for Laboratory Accreditation (A2LA) (U.S.A.), Certificate No. 1152.01.
2. The Federal Communications Commission (FCC) (U.S.A.), Registration No. 90715.
3. The Israel Ministry of the Environment (Israel), Registration No. 1104/01.
4. The Voluntary Control Council for Interference by Information Technology Equipment (VCCI) (Japan), Registration Numbers: C-1350, R-1285.
5. Industry Canada (Canada), File No. IC 4025.
6. TUV Product Services, England, ASLLAS No. 97201.
7. Nemko (Norway), Authorization No. ELA 207.

I.T.L. Product Testing Ltd. is accredited by the American Association for Laboratory Accreditation (A2LA) and the results shown in this test report have been determined in accordance with I.T.L.'s terms of accreditation unless stated otherwise in the report.

1.3 Product Description

The MobileAccess 860 WLAN Solution delivers pervasive WLAN coverage throughout enterprise environments using a unique multi-service wireless architecture. With the MA-860 approach, enterprises can seamlessly translate their WLAN investments and design expertise into a comprehensive, multi-service wireless solution.

The MA-860 combines WLAN services with signals from other wireless sources, including voice and data services from multiple wireless operators, public safety, and building automation applications. It then distributes the combined RF signals over a common set of broadband cables and antennas. One-Click calibration between the MA-860 module and the MobileAccess Wi-Fi Coverage Expander (WCE) ensures optimal coverage by mirroring the coverage footprint and system behavior of “AP-on-Ceiling” deployments for 802.11a and 802.11b/g WLAN services.

This Wire-it-Once™ approach spreads WLAN deployment costs across multiple wireless service needs, providing facility-wide coverage for WLAN and all other wireless services while creating a flexible infrastructure that adapts to evolving technology requirements.

In addition, the MA-860 WLAN solution locates Access Points (APs) in secure telecom closets alongside other LAN internetworking equipment, yielding significant operational benefits:

- Provides physical security of the APs
- Makes APs more accessible to IT staff
- Reduces ongoing operational expenses

1.4 Test Methodology

Both conducted and radiated testing were performed according to the procedures in ANSI C63.4: 2003. Radiated testing was performed at an antenna to EUT distance of 3 meters.

1.5 Test Facility

The radiated emissions tests were performed at I.T.L.’s testing facility at Kfar Bin-Nun, Israel. This site is a FCC listed test laboratory (FCC Registration No. 90715, date of listing August 22, 2006).

I.T.L.’s EMC Laboratory is also accredited by A2LA, certificate No. 1152.01.

1.6 Measurement Uncertainty

Radiated Emission

The Open Site complies with the ± 4 dB Normalized Site Attenuation requirements of ANSI C63.4-2003. In accordance with Paragraph 5.4.6.1 of this standard, this tolerance includes instrumentation calibration errors, measurement technique errors, and errors due to site anomalies.

2. System Test Configuration

2.1 *Justification*

The EUT consists of the 860M, WCE and 4 identical access points. The system combines 802.11 signals with the cellular signals. The cellular signals are represented in the setup by the CELL and PCS portion of the setup, which were connected to the EUT through MobileAccess standard infrastructure (i.e. RIU, BU, RHU and a controller) to represent a normal installation of the EUT.

An “Exercise” SW on the laptops was used to trigger the access points to transmit continuously, while the EUT output was connected to the spectrum analyzer.

2.2 *EUT Exercise Software*

The Access Points (APs) (as part of the EUT) were triggered to transmit using an “Exercise SW”.

The program “Air Magnet” was used to trigger the AP to continuously transmit packets.

2.3 *Special Accessories*

No special accessories were needed to achieve compliance.

2.4 *Equipment Modifications*

No modifications were necessary in order to achieve compliance.

2.5 Configuration of Tested System

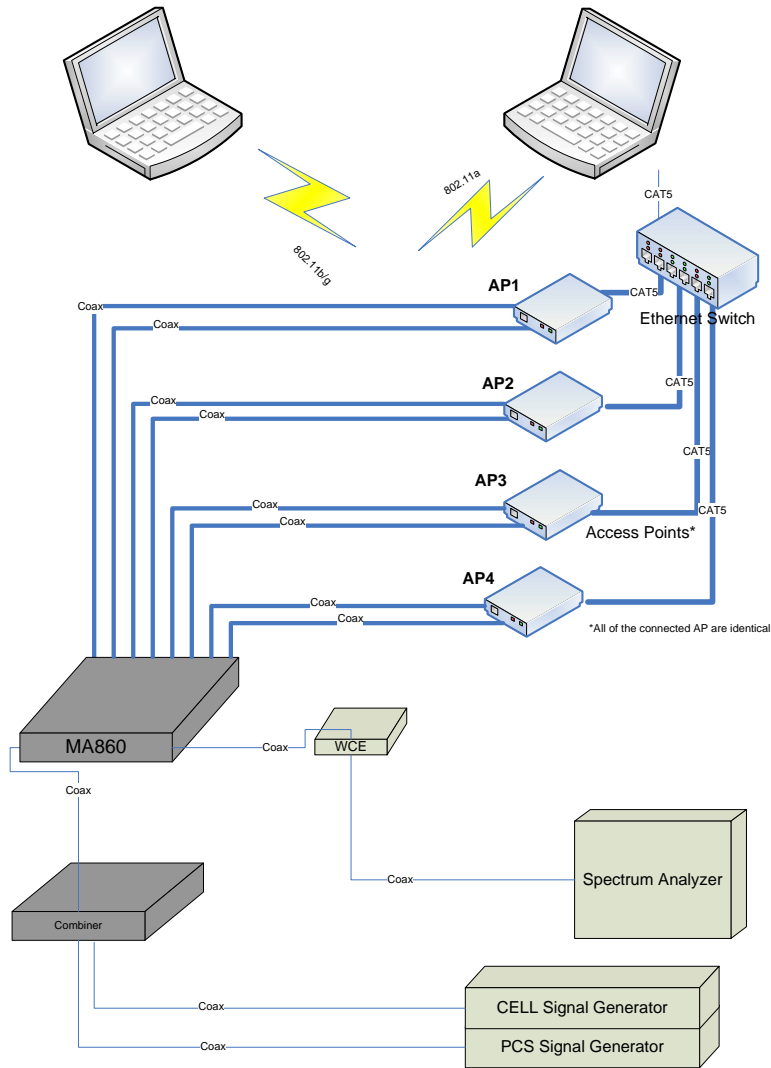

Figure 1. Configuration of Tested System

Note: The system was tested using four identical Cisco Access Points M/N 1242, S/N FTX1108B616, S/N FTX11013B13Q, S/N FTX1108B60Z, S/N FTX1108B605, FCC ID: LDK102056.

3. Theory of Operation

3.1 Theory of Operation



Making Wireless an Indoor State of Mind

▶ MA-860 WLAN Solution

MobileAccess 860 WLAN Module

MA-860 Solution Overview

The MobileAccess 860 WLAN Solution delivers pervasive WLAN coverage throughout enterprise environments using a unique multi-service wireless architecture. With the MA-860 approach, enterprises can seamlessly translate their WLAN investments and design expertise into a comprehensive, multi-service wireless solution.

The MA-860 combines WLAN services with signals from other wireless sources, including voice and data services from multiple wireless operators, public safety, and building automation applications. It then distributes the combined RF signals over a common set of broadband cables and antennas. One-Click calibration between the MA-860 module and the MobileAccess Wi-Fi Coverage Expander (WCE) ensures optimal coverage by mirroring the coverage footprint and system behavior of "AP-on-Ceiling" deployments for 802.11a and 802.11b/g WLAN services.

This Wire-it-Once™ approach spreads WLAN deployment costs across multiple wireless service needs, providing facility-wide coverage for WLAN and all other wireless services while creating a flexible infrastructure that adapts to evolving technology requirements.

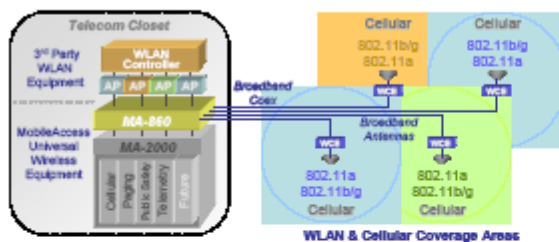

In addition, the MA-860 WLAN solution locates Access Points (APs) in secure telecom closets alongside other LAN internetworking equipment, yielding significant operational benefits:

- ▶ Provides physical security of the APs
- ▶ Makes APs more accessible to IT staff
- ▶ Reduces ongoing operational expenses



Benefits

Cost-Effective Multi-Service Solution

- ▶ Delivers WLAN and other wireless RF signals over a single multi-service infrastructure
- ▶ Spreads WLAN deployment costs across multiple wireless services

Dependable WLAN Coverage

- ▶ MobileAccess WLAN architecture mirrors the behaviors and coverage footprint of "AP-on-Ceiling" deployment
- ▶ One-Click compensation ensures optimal 802.11b/g and 802.11a coverage
- ▶ Dedicated AP to antenna relationships ensure transparent support for WLAN applications such as VOIP and location services (RTLS)
- ▶ Redundant power option

Centralized & Secure AP Management

- ▶ Lowers operating expenses
- ▶ Provides physical security and simplifies management

Proactive End-to-End Monitoring

- ▶ Remote SNMP monitoring for status, alerting, and fault detection
- ▶ Monitoring extends to attached multi-service antennas

Simplified IT Deployment Model

- ▶ Uses standard WLAN design techniques



8391 Old Courthouse Road, Suite 300, Vienna, VA 22182
Tel: (866)438-9288, (703) 848-0200 TAC: (800) 787-1266 Fax: (703) 848-0280

www.mobileaccess.com

MA-860 Product Specifications

802.11 RF Parameters Power

860(M/R) with Wi-Fi Coverage Expander (WCE):

	802.11a	802.11b/g
Gain TX (dB)	0	0
Output Power (dBm)	17	b: 20 g: 17
Gain RX (dB)	4	4
NF RX (dB)	5	5
Flatness (dB)	+/- 2.0	+/- 1.5

Power
2 DC Power Inputs
DC-1 = 28V Mandatory DC Power, 66 Watts
DC-2= 9.8V Optional Redundant Power, 40 Watts

Physical Specifications

Dimensions
860(M/R): 242 mm x 279 mm x 38 mm
(9.54 in x 10.98 in x 1.5 in)
WCE: 130 mm x 120 mm x 20 mm
(5.12 in x 4.73in x 0.8 in)

Weight
860(M/R): 2.82 kg (6.2 lb)
WCE: 0.80 kg (1.8 lb)

860(M/R) Module Standalone:

	802.11a	802.11b/g
Insertion Loss (dB)	3	2
Flatness (dB)	+/- 1.0	+/- 1.0

Environmental Specifications

Temperature
Operating: 0°C to +50°C (32°F to 122°F)
Storage: -20°C to +85°C (-4°C to 185°C)

Humidity
Operating: 95% (non-condensing)
Storage: 95% (non-condensing)

Mobile Services Parameters

	Cell		PCS
Band (MHz)	698-960		1710-1990
Insertion Loss (dB)			
MA-860	1.0		2.5
WCE	1.2		3.5
System	2.2		6.0

Ordering Information

860M: 860 WLAN Module
860R: 860 WLAN Module
- Redundant Power Supply Option
WCE: Wi-Fi Coverage Expander

RF Connections

860(M/R)

802.11 b/g: (4) SMA Female, 50 ohm
802.11 a: (4) SMA Female, 50 ohm
Mobile Services: (4) SMA Female, 50 ohm
Antenna Ports: (4) N-type Female, 50 ohm

Accessory Kits for mounting 860(M/R):

AK-860-1000: 860 with MA-1000
AK-860-1200: 860 with MA-1200
AK-860-MDLT: 860 with ModuLite
AK-860-2000: 860 with MA-2000
AK-860-SA: 860 stand alone
AK-860-2000L: 860 with MA-2000 Lite
AK-860-PWR: Redundant Power Supply

WCE

Coax (860 facing): (1) N-type Male
Coax (Ant facing): (1) N-type Female

Standards and Approvals

FCC-47, CFR 15.109, Part 15 Sections B, C, and E
UL / IEC 60950 -1
UL1950 Fire Safety requirements
UL2043 Fire/Plenum (WCE)
CE EN 60950
CAN/CSA C22.2 No 60950

Wiring Diagram

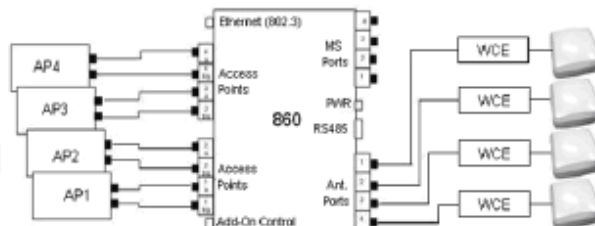

Management

The 860(M/R) can be configured and monitored through either a local RS-485 connection or a Web browser application via an RJ-45 Ethernet connection

8391 Old Courthouse Road, Suite 300, Vienna, VA 22182
Tel: (866)436-9286, (703) 848-0200 TAC: (800) 787-1288 Fax: (703) 848-0280
www.mobileaccess.com

4. Spurious Radiated Emission in the Restricted Band, Below 1 GHz 2.4GHz Transmitter 802.11b/g+802.11a Signals

4.1 Test Specification

9kHz-1000 MHz, F.C.C., Part 15, Subpart C

4.2 Test Procedure

The E.U.T. operation mode and test set-up are as described in Section 3.

See Section 3.1 Justification of the System Test Configuration concerning the E.U.T. orientation for this test.

A preliminary measurement to characterize the E.U.T was performed inside the shielded room at a distance of 3 meters, using peak detection mode and broadband antennas. The preliminary measurements produced a list of the highest emissions. The E.U.T was then transferred to the open site, and placed on a remote-controlled turntable. The E.U.T was placed on a non-metallic table, 0.8 meters above the ground. The configuration tested is shown in Figure 3.1.

The frequency range 9 kHz-1000 MHz was scanned, and the list of the highest emissions was verified and updated accordingly.

The levels of the emissions within the frequency ranges of the restricted bands (Section 15.205 of FCC Part 15) were compared to the limits of the table in Section 15.209 (a), General Requirements.

The emissions were measured using a computerized EMI receiver complying to CISPR 16 requirements. The specification limits and applicable correction factors are loaded to the receiver via a 3.5" floppy disk.

In the frequency range 9 kHz-30 MHz, the loop antenna was rotated on its vertical axis, The antenna height (center of loop) was 1 meter.

In the frequency range 30-1000 MHz, the readings were maximized by adjusting the antenna height between 1-4 meters, the turntable azimuth between 0-360°, and the antenna polarization.

Verification of the E.U.T emissions was based on the following methods:

- Turning the E.U.T on and off.

- Using a frequency span less than 10 MHz.

- Observation of the signal level during turntable rotation. Background noise is not affected by the rotation of the E.U.T.

The E.U.T. was tested at the operating frequencies of 2412, 2437, and 2462 MHz using the following modulations: DBPSK, BPSK, CCK, and 64QAM.



4.3 Test Data

JUDGEMENT: Passed by 3.5 dB.

The margin between the emission level and the specification limit is 3.5 dB in the worst case at the frequency of 39.70 MHz, vertical polarization.

The EUT met the requirements of the F.C.C. Part 15, Subpart C, specification.

The results for all three operating frequencies and modulations were the same.

TEST PERSONNEL:

Tester Signature: _____

Date: 05.02.08

Typed/Printed Name: A. Sharabi

Radiated Emission

E.U.T Description WLAN Module With WCE (WiFi Coverage Extender) for DAS With Four Cisco 1242 Access Points
 Type 860M With WCE
 Serial Number: 1. 860M: 73903D
 2. WCE: 739038

Specification: FCC Part 15, Subpart C

Antenna Polarization: Horizontal Frequency range: 30 MHz to 300 MHz
 Antenna: 3 meters distance Detectors: Peak, Quasi-peak

Frequency	Peak Amp	QP Amp	Correction	Specification	Margin
(MHz)	(dB μ V/m)	(dB μ V/m)	(dB)	(dB μ V/m)	(dB)
39.70	31.7	27.3	13.4	40.0	-12.7
46.92	28.4	23.5	12.1	40.0	-16.5
162.58	36.0	31.7	15.4	43.5	-11.8
175.07	40.8	35.8	15.9	43.5	-7.7
207.20	37.1	32.2	18.0	43.5	-11.3
242.11	40.6	36.0	20.0	46.0	-10.0

**Figure 2. Radiated Emission. Antenna Polarization: HORIZONTAL.
 Detectors: Peak, Quasi-peak**

Note: Margin refers to the test results obtained minus specified requirement; thus a positive number indicates failure, and a negative result indicates that the product passes the test.

Radiated Emission

E.U.T Description WLAN Module With WCE (WiFi Coverage Extender) for DAS With Four Cisco 1242 Access Points
Type 860M With WCE
Serial Number: 1. 860M: 73903D
 2. WCE: 739038

Specification: FCC Part 15, Subpart C

Antenna Polarization: Horizontal
Antenna: 3 meters distance

Frequency range: 30 MHz to 300 MHz
Detectors: Peak, Quasi-peak

 13:48:32 FEB 04, 2008

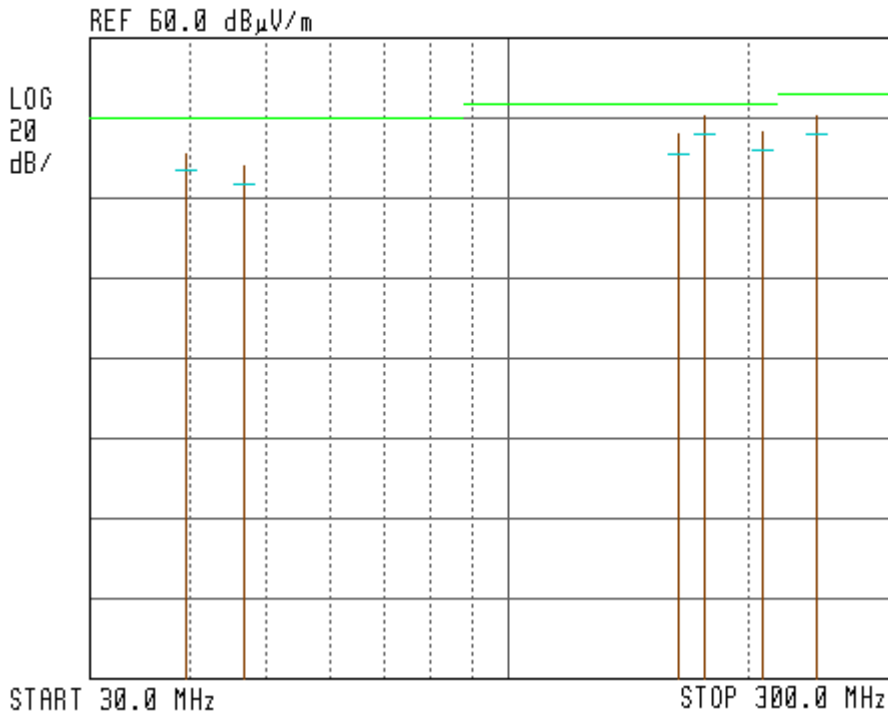

**Figure 3. Radiated Emission. Antenna Polarization: HORIZONTAL
Detectors: Peak, Quasi-peak**

Note:

1. Horizontal axis shows logarithmic frequency scale.
2. The vertical axis shows amplitude (in dB μ V/m).
3. Peak detection is designated by the top of each vertical line.
4. Quasi-peak detection is designated by the first dash mark (from the top) of each vertical line.

Radiated Emission

E.U.T Description WLAN Module With WCE (WiFi Coverage Extender) for DAS With Four Cisco 1242 Access Points

Type 860M With WCE

Serial Number: 1. 860M: 73903D
 2. WCE: 739038

Specification: FCC Part 15, Subpart C

Antenna Polarization: Vertical
 Antenna: 3 meters distance

Frequency range: 30 MHz to 300 MHz
 Detectors: Peak, Quasi-peak

Frequency (MHz)	Peak Amp (dBμV/m)	QP Amp (dBμV/m)	Correction (dB)	Specification (dBμV/m)	Margin (dB)
34.93	36.0	32.1	14.7	40.0	-7.9
39.70	41.6	36.5	13.4	40.0	-3.5
46.15	44.4	34.8	12.2	40.0	-5.2
162.58	41.6	38.8	15.4	43.5	-4.7
175.07	40.9	37.6	15.9	43.5	-5.9
242.11	38.6	34.7	20.0	46.0	-11.3

**Figure 4. Radiated Emission. Antenna Polarization: VERTICAL.
 Detectors: Peak, Quasi-peak**

Note: Margin refers to the test results obtained minus specified requirement; thus a positive number indicates failure, and a negative result indicates that the product passes the test.

Radiated Emission

E.U.T Description WLAN Module With WCE (WiFi Coverage Extender) for DAS With Four Cisco 1242 Access Points
 Type 860M With WCE
 Serial Number: 1. 860M: 73903D
 2. WCE: 739038

Specification: FCC Part 15, Subpart C

Antenna Polarization: Vertical
 Antenna: 3 meters distance

Frequency range: 30 MHz to 300 MHz
 Detectors: Peak, Quasi-peak

12:34:02 FEB 04, 2008

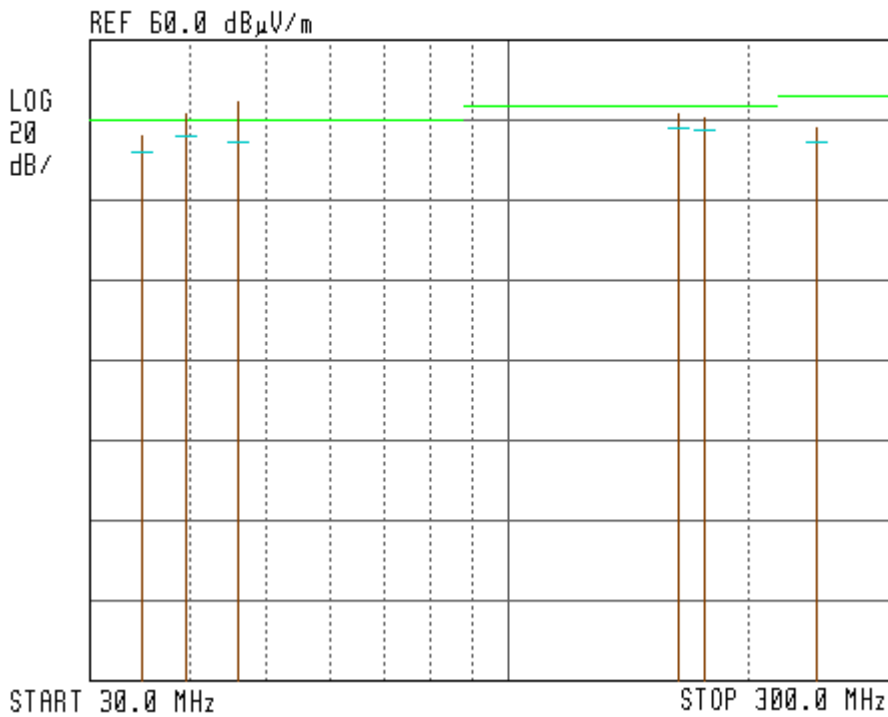

Figure 5. Radiated Emission. Antenna Polarization: VERTICAL. Detectors: Peak, Quasi-peak

Note:

1. Horizontal axis shows logarithmic frequency scale.
2. The vertical axis shows amplitude (in dB μ V/m).
3. Peak detection is designated by the top of each vertical line.
4. Quasi-peak detection is designated by the first dash mark (from the top) of each vertical line.

4.4 Test Instrumentation Used, Radiated Measurements

Instrument	Manufacturer	Model	Serial Number	Calibration	Period
EMI Receiver	HP	85422E	3411A00102	November 12, 2007	1 year
RF Section	HP	85420E	3427A00103	November 12, 2007	1 year
Antenna Bioconical	ARA	BCD 235/B	1041	March 22, 2007	1 year
Antenna Log Periodic	ARA	LPD-2010/A	1038	November 22, 2007	1 year
Active Loop Antenna	EMCO	6502	9506-2950	October 15, 2007	1 year
Antenna Mast	ARA	AAM-4A	1001	N/A	N/A
Turntable	ARA	ART-1001/4	1001	N/A	N/A
Mast & Table Controller	ARA	ACU-2/5	1001	N/A	N/A
Printer	HP	LaserJet 2200	JPKG19982	N/A	N/A

4.5 **Field Strength Calculation**

The field strength is calculated directly by the EMI Receiver software, and a "Correction Factors" data disk, using the following equation:

$$[\text{dB}\mu\text{v}/\text{m}] \text{ FS} = \text{RA} + \text{AF} + \text{CF}$$

- FS: Field Strength [dB μ v/m]
- RA: Receiver Amplitude [dB μ v]
- AF: Receiving Antenna Correction Factor [dB/m]
- CF: Cable Attenuation Factor [dB]

No external pre-amplifiers are used.

5. Spurious Radiated Emission in the Restricted Band, Above 1 GHz 2.4GHz Transmitter 802.11 b/g + 802.11a Signals

5.1 Radiated Emission Above 1 GHz

The E.U.T operation mode and test set-up are as described in Section 3.

See Section 3.1 Justification of the System Test Configuration concerning the E.U.T. orientation for this test.

A preliminary measurement to characterize the E.U.T was performed inside the shielded room, using peak detection mode and broadband antennas. The preliminary measurements produced a list of the highest emissions. The E.U.T was then transferred to the open site, and placed on a remote-controlled turntable. The E.U.T was placed on a non-metallic table, 0.8 meters above the ground. The configuration tested is shown in Figure 3.1.

The levels of the emissions within the frequency ranges of the restricted bands (Section 15.205 of FCC Part 15) were compared to the limits of the table in Section 15.209 (a), General Requirements.

In the frequency range 1-2.9 GHz, a computerized EMI receiver complying to CISPR 16 requirements was used.

In the frequency range 2.9-25.0 GHz, a spectrum analyzer including a low noise amplifier was used. During average measurements, the IF bandwidth was 1 MHz and the video bandwidth was 100Hz. During peak measurements, the IF bandwidth was 1 MHz and the video bandwidth was 3 MHz.

The test distance was 3 meters.

The readings were maximized by adjusting the antenna height between 1-4 meters, the turntable azimuth between 0-360°, and the antenna polarization.

Verification of the E.U.T emissions was based on the following methods: turning the E.U.T on and off; using a frequency span less than 10 MHz; observation of the signal level during turntable rotation. (Background noise is not affected by the rotation of the E.U.T.)

The E.U.T. was tested at the operating frequencies of 2412, 2437, and 2462 MHz using the following modulations: DBPSK, BPSK, CCK, and 64QAM.

5.2 Test Data

JUDGEMENT: Passed by 11.4 dB

For the operation frequency of 2412 MHz, the margin between the emission level and the specification limit is 11.5 dB in the worst case at the frequency of 4824.00 MHz, vertical polarization.

For the operation frequency of 2437 MHz, the margin between the emission level and the specification limit is 11.4 dB in the worst case at the frequency of 4874.00 MHz, vertical polarization.

For the operation frequency of 2462 MHz, the margin between the emission level and the specification limit is 15.1 dB in the worst case at the frequency of 4924.00 MHz, vertical polarization.

The results for all modulations were the same.

The EUT met the requirements of the F.C.C. Part 15, Subpart C, specification.

TEST PERSONNEL:

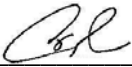
Tester Signature: 

Date: 05.02.08

Typed/Printed Name: A. Sharabi

Radiated Emission Above 1 GHz

E.U.T Description WLAN Module With WCE (WiFi Coverage Extender) for DAS With Four Cisco 1242 Access Points

Type 860M With WCE

Serial Number: 1. 860M: 73903D
 2. WCE: 739038

Specification: FCC, Part 15, Subpart C

Antenna Polarization: Horizontal/Vertical Frequency range: 1.0 GHz to 25.0 GHz
 Test Distance: 3 meters Detector: Peak
 Operation Frequency: 2412 MHz

Freq.	Polarity	Peak Amp	Peak. Specification	Peak. Margin
(MHz)	(H/V)	(dBμV/m)	(dB μV/m)	(dB)
4824.00	H	49.6*	74.0	-24.4
4824.00	V	52.5*	74.0	-21.5

Figure 6. Radiated Emission. Antenna Polarization: HORIZONTAL / VERTICAL. Detector: Peak

Margin refers to the test results obtained minus specified requirement; thus a positive number indicates failure, and a negative result indicates that the product passes the test.

“Peak Amp” includes correction factor.

* “Correction Factor” = Antenna Factor + Cable Loss- Low Noise Amplifier Gain

Radiated Emission Above 1 GHz

E.U.T Description	WLAN Module With WCE (WiFi Coverage Extender) for DAS With Four Cisco 1242 Access Points
Type	860M With WCE
Serial Number:	1. 860M: 73903D 2. WCE: 739038

Specification: FCC, Part 15, Subpart C

Antenna Polarization: Horizontal/Vertical	Frequency range: 1.0 GHz to 25.0 GHz
Test Distance: 3 meters	Detector: Average
Operation Frequency: 2412 MHz	

Freq.	Polarity	Average Amp	Average Specification	Peak. Margin
(MHz)	(H/V)	(dBμV/m)	(dB μV/m)	(dB)
4824.00	H	39.8*	54.0	-14.2
4824.00	V	42.5*	54.0	-11.5

Figure 7. Radiated Emission. Antenna Polarization: HORIZONTAL / VERTICAL. Detector: Average

Notes:

Margin refers to the test results obtained minus specified requirement; thus a positive number indicates failure, and a negative result indicates that the product passes the test.

“Average Amp” includes correction factor.

* Correction Factor = Antenna Factor + Cable Loss- Low Noise Amplifier Gain

Radiated Emission Above 1 GHz

E.U.T Description WLAN Module With WCE (WiFi Coverage Extender) for DAS With Four Cisco 1242 Access Points

Type 860M With WCE

Serial Number: 1. 860M: 73903D
 2. WCE: 739038

Specification: FCC, Part 15, Subpart C

Antenna Polarization: Horizontal/Vertical Frequency range: 1.0 GHz to 25.0 GHz
 Test Distance: 3 meters Detector: Peak
 Operation Frequency: 2437 MHz

Freq.	Polarity	Peak Amp	Peak. Specification	Peak. Margin
(MHz)	(H/V)	(dBμV/m)	(dB μV/m)	(dB)
4874.00	H	46.1*	74.0	-27.9
4874.00	V	49.3*	74.0	-24.7

**Figure 8. Radiated Emission. Antenna Polarization: HORIZONTAL / VERTICAL.
 Detector: Peak**

Margin refers to the test results obtained minus specified requirement; thus a positive number indicates failure, and a negative result indicates that the product passes the test.

“Peak Amp” includes correction factor.

* “Correction Factor” = Antenna Factor + Cable Loss- Low Noise Amplifier Gain

Radiated Emission Above 1 GHz

E.U.T Description	WLAN Module With WCE (WiFi Coverage Extender) for DAS With Four Cisco 1242 Access Points
Type	860M With WCE
Serial Number:	1. 860M: 73903D 2. WCE: 739038

Specification: FCC, Part 15, Subpart C

Antenna Polarization: Horizontal/Vertical	Frequency range: 1.0 GHz to 25.0 GHz
Test Distance: 3 meters	Detector: Average
Operation Frequency: 2437 MHz	

Freq.	Polarity	Average Amp	Average Specification	Peak. Margin
(MHz)	(H/V)	(dBμV/m)	(dB μV/m)	(dB)
4874.00	H	37.5*	54.0	-16.5
4874.00	V	42.6*	54.0	-11.4

Figure 9. Radiated Emission. Antenna Polarization: HORIZONTAL / VERTICAL. Detector: Average

Notes:

Margin refers to the test results obtained minus specified requirement; thus a positive number indicates failure, and a negative result indicates that the product passes the test.

“Average Amp” includes correction factor.

* Correction Factor = Antenna Factor + Cable Loss- Low Noise Amplifier Gain

Radiated Emission Above 1 GHz

E.U.T Description WLAN Module With WCE (WiFi Coverage Extender) for DAS With Four Cisco 1242 Access Points

Type 860M With WCE

Serial Number: 1. 860M: 73903D
 2. WCE: 739038

Specification: FCC, Part 15, Subpart C

Antenna Polarization: Horizontal/Vertical Frequency range: 1.0 GHz to 25.0 GHz
 Test Distance: 3 meters Detector: Peak
 Operation Frequency: 2462 MHz

Freq.	Polarity	Peak Amp	Peak. Specification	Peak. Margin
(MHz)	(H/V)	(dBμV/m)	(dB μV/m)	(dB)
4924.00	H	45.6*	74.0	-28.4
4924.00	V	47.2*	74.0	-26.8

Figure 10. Radiated Emission. Antenna Polarization: HORIZONTAL / VERTICAL. Detector: Peak

Margin refers to the test results obtained minus specified requirement; thus a positive number indicates failure, and a negative result indicates that the product passes the test.

“Peak Amp” includes correction factor.

* “Correction Factor” = Antenna Factor + Cable Loss- Low Noise Amplifier Gain

Radiated Emission Above 1 GHz

E.U.T Description	WLAN Module With WCE (WiFi Coverage Extender) for DAS With Four Cisco 1242 Access Points
Type	860M With WCE
Serial Number:	1. 860M: 73903D 2. WCE: 739038

Specification: FCC, Part 15, Subpart C

Antenna Polarization: Horizontal/Vertical	Frequency range: 1.0 GHz to 25.0 GHz
Test Distance: 3 meters	Detector: Average
Operation Frequency: 2462 MHz	

Freq.	Polarity	Average Amp	Average Specification	Peak. Margin
(MHz)	(H/V)	(dBμV/m)	(dB μV/m)	(dB)
4924.00	H	36.7*	54.0	-17.3
4924.00	V	38.9*	54.0	-15.1

Figure 11. Radiated Emission. Antenna Polarization: HORIZONTAL / VERTICAL. Detector: Average

Notes:

Margin refers to the test results obtained minus specified requirement; thus a positive number indicates failure, and a negative result indicates that the product passes the test.

“Average Amp” includes correction factor.

* Correction Factor = Antenna Factor + Cable Loss- Low Noise Amplifier Gain

5.3 Test Instrumentation Used, Radiated Measurements Above 1 GHz

Instrument	Manufacturer	Model	Serial Number	Calibration	Period
Receiver	HP	85422E	3411A00102	November 12, 2007	1 year
RF Section	HP	85420E	3427A00103	November 12, 2007	1 year
Antenna Mast	ARA	AAM-4A	1001	N/A	N/A
Turntable	ARA	ART-1001/4	1001	N/A	N/A
Mast & Table Controller	ARA	ACU-2/5	1001	N/A	N/A
Printer	HP	LaserJet 2200	JPKG19982	N/A	N/A
Antenna-Log Periodic	A.H.System	SAS-200/511	253	February 4, 2007	2 years
Double Ridged Waveguide Horn Antenna	EMCO	3115	29845	March 15, 2006	2 years
Horn Antenna	ARA	SWH-28	1008	December 8, 2006	2 year
Low Noise Amplifier	DBS MICROWAVE	LNA-DBS-0411N313	013	November 2, 2007	1 year
Low Noise Amplifier	Sophia Wireless	LNA 28-B	232	February 8, 2007	1 year
Low Noise Amplifier	MK Milliwave	MKT6-3000 400-30-13P	399	February 8, 2007	1 year
Spectrum Analyzer	HP	8592L	3826A01204	February 22, 2007	1 year
Spectrum Analyzer	HP	8546E	3442A00275	November 14, 2007	1 year
Printer	HP	LaserJet 2200	JPKG19982	N/A	N/A

6. 26 dB Bandwidth 2.4 GHz Transmitter 802.11 b/g + 802.11a Signals

6.1 Test procedure

The E.U.T. was set to the applicable test frequency. The E.U.T. antenna terminal was connected to the spectrum analyzer through an external attenuator (20 dB) and appropriate coaxial cable (cable loss = 0.5 dB). The spectrum analyzer was set to 100 kHz resolution BW. The spectrum bandwidth of the E.U.T. was measured and recorded.

The E.U.T. was tested at 2412, 2437, and 2462 MHz with the following modulations: DBPSK (1Mbit/sec), BPSK (6Mbit/sec), CCK (11Mbit/sec) and 64QAM (54Mbit/sec).

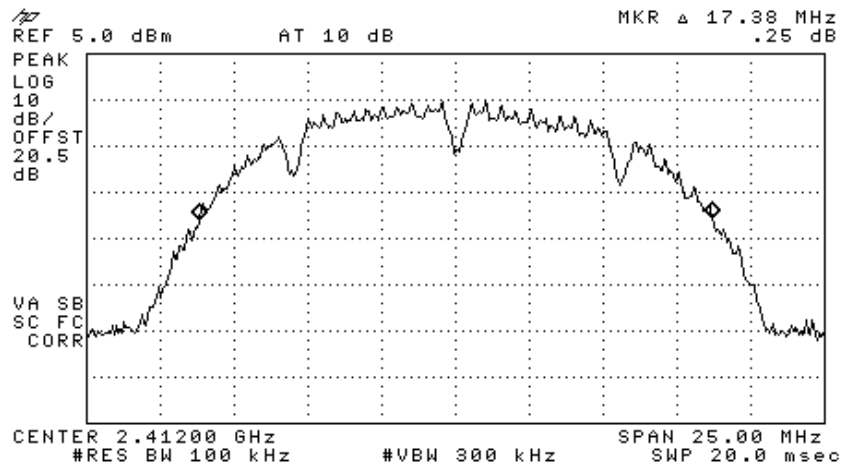

Figure 12 —2412 MHz DBPSK

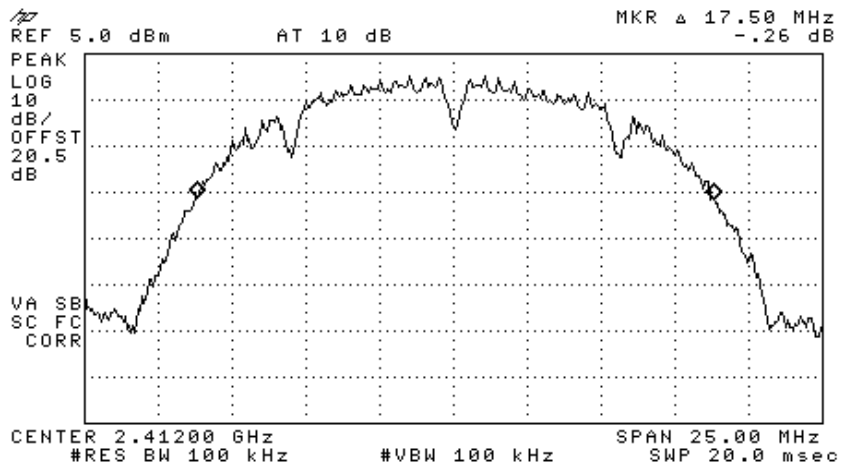

Figure 13 —2412 MHZ BPSK

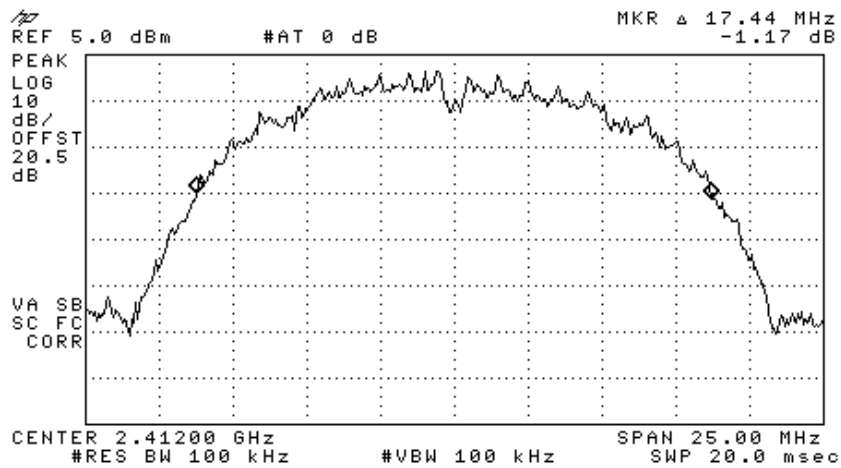

Figure 14 —2412 MHz CCK

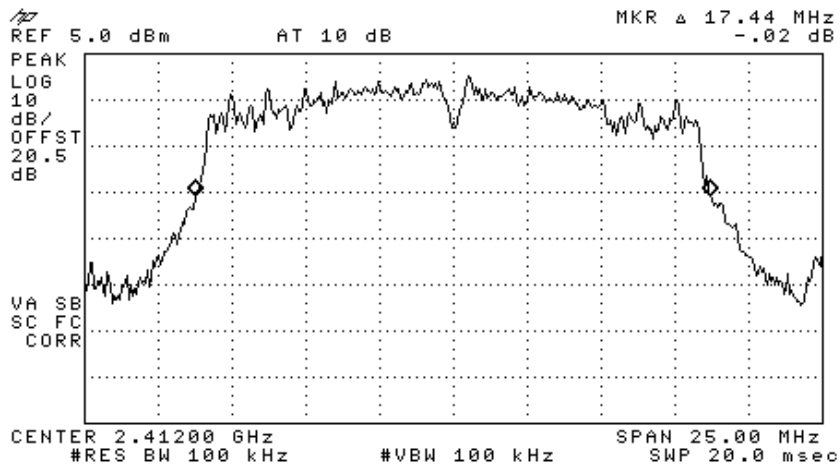

Figure 15 —2412 MHz 64QAM

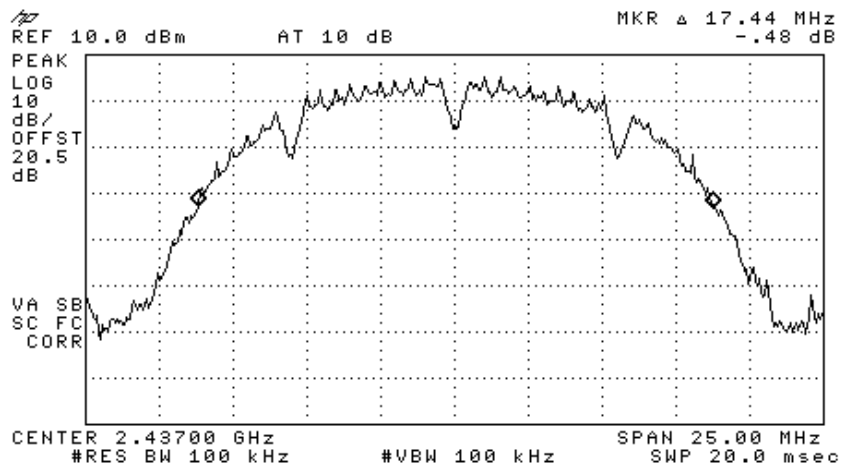

Figure 16 —2437 MHz DBPSK

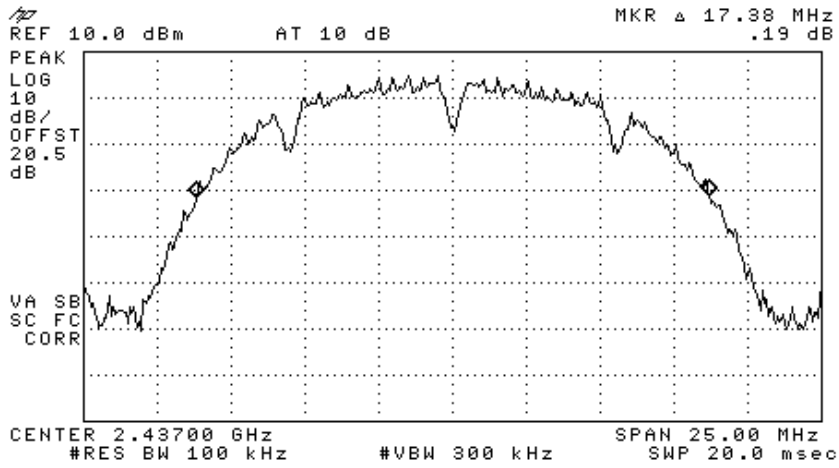

Figure 17 —2437 MHz BPSK

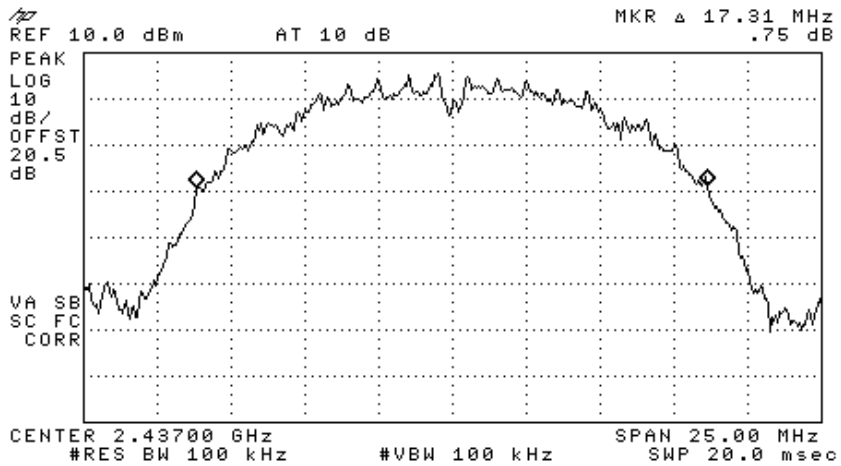

Figure 18 —2437 MHz CCK

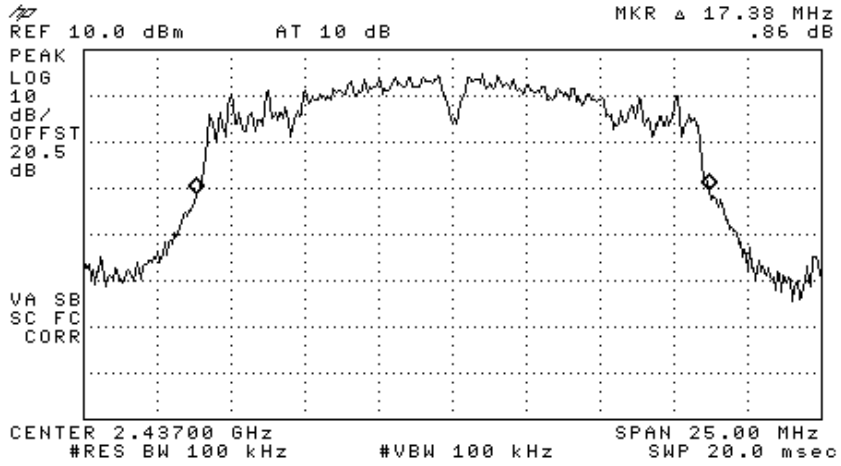

Figure 19 —2437 MHz 64QAM

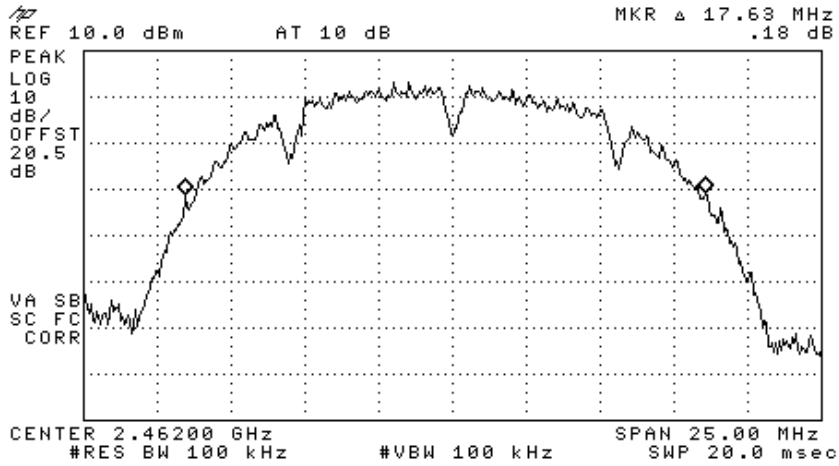

Figure 20 —2462 MHz DBPSK

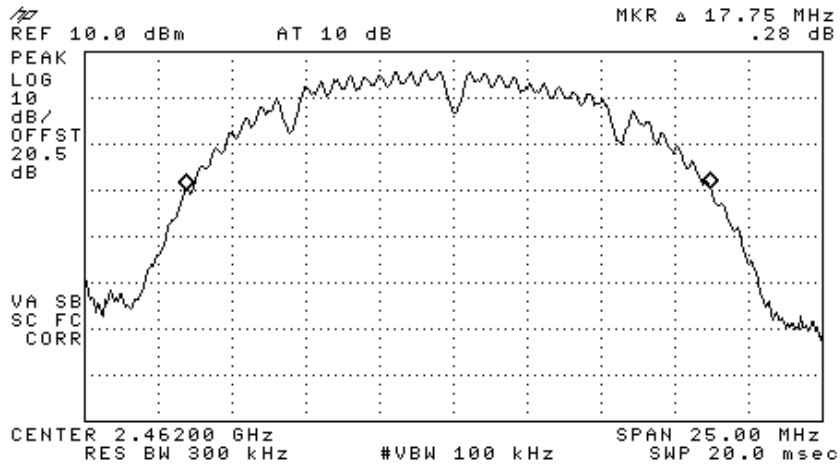

Figure 21 —2462 MHz BPSK

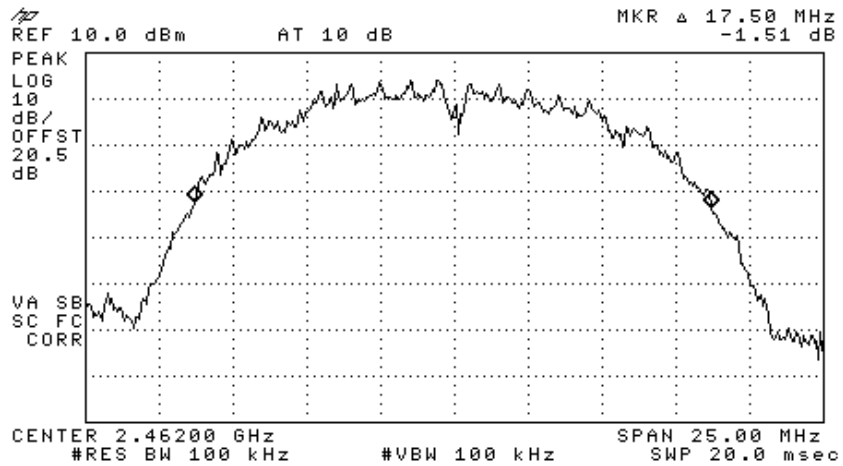

Figure 22 —2462 MHz CCK

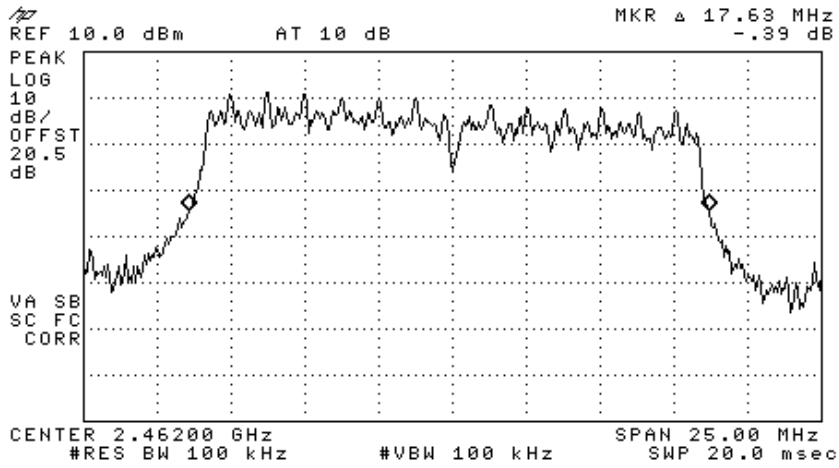

Figure 23 —2462 MHZ 64QAM

Operation Frequency (MHz)	Modulation	26 dB Bandwidth (dBm)
2412	DBPSK	17.38
	BPSK	17.50
	CCK	17.44
	64QAM	17.44
2437	DBPSK	17.44
	BPSK	17.38
	CCK	17.31
	64QAM	17.38
2462	DBPSK	17.63
	BPSK	17.75
	CCK	17.50
	64QAM	17.63

TEST PERSONNEL:

Tester Signature: *E. Pitt*

Date: 05.02.08

Typed/Printed Name: E. Pitt

6.2 Test Equipment Used.

26 dB Minimum Bandwidth

Instrument	Manufacturer	Model	Serial/Part Number	Calibration	
				Last Calibr.	Period
Spectrum Analyzer	HP	8592L	3826A01204	February 22, 2007	1 year
Attenuator	Jyebao	-	FAT-AM5AF5G6G2W20	May 9, 2007	1 year
Cable	Rhophase	KPS-5000-KPS	A1674	February 8, 2007	1 year

Figure 24 Test Equipment Used

7. Maximum Transmitted Peak Power Output 2.4 GHz Transmitter 802.11 b/g + 802.11a Signals

7.1 Test procedure

The E.U.T. antenna terminal was connected to the Spectrum Analyzer through an external attenuator (20 dB) and an appropriate coaxial cable (cable loss = 0.5 dB). The Spectrum Analyzer was set to 1.0 MHz resolution BW. Peak power level was measured at selected operation frequencies.

The E.U.T. was tested at 2412, 2437, and 2462 MHz with the following modulations: DBPSK (1Mbit/sec), BPSK (6Mbit/sec), CCK (11Mbit/sec) and 64QAM (54Mbit/sec).

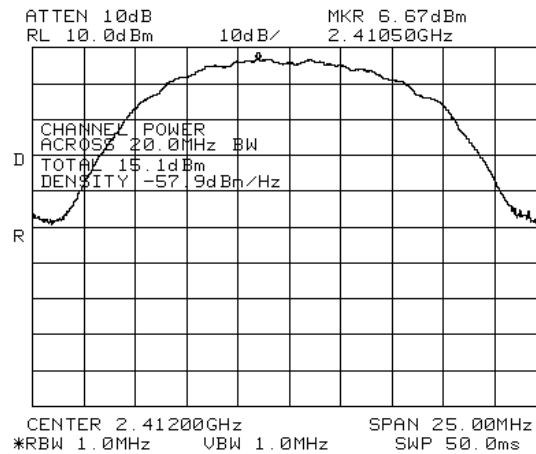

Figure 25 2412 DBPSK

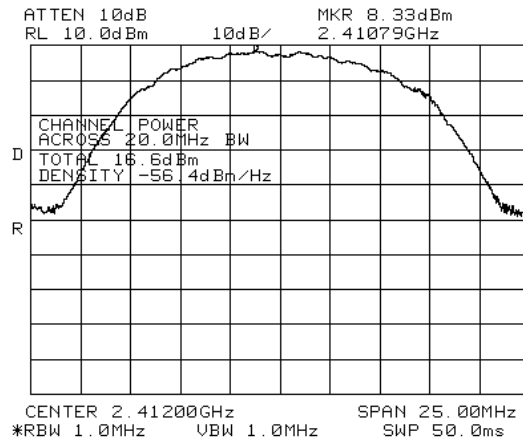

Figure 26 2412 MHz BPSK

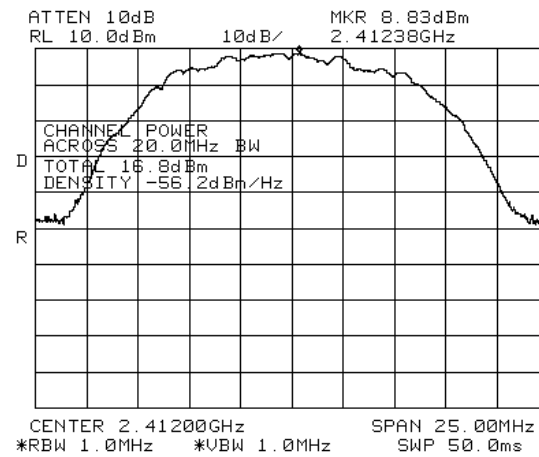

Figure 27 2412 MHz CCK

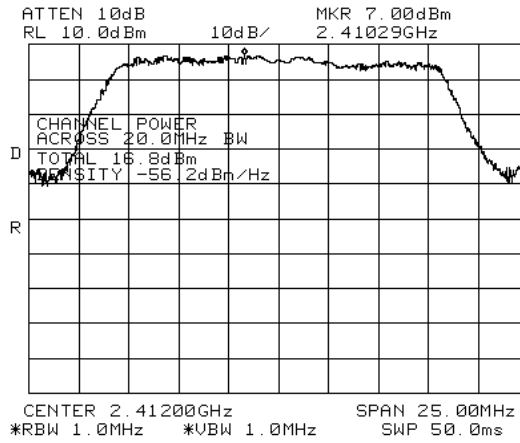

Figure 28 2412 MHz 64QAM

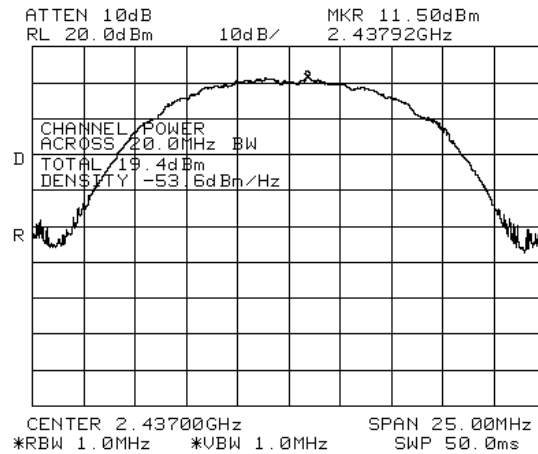

Figure 29 2437 MHz DBPSK

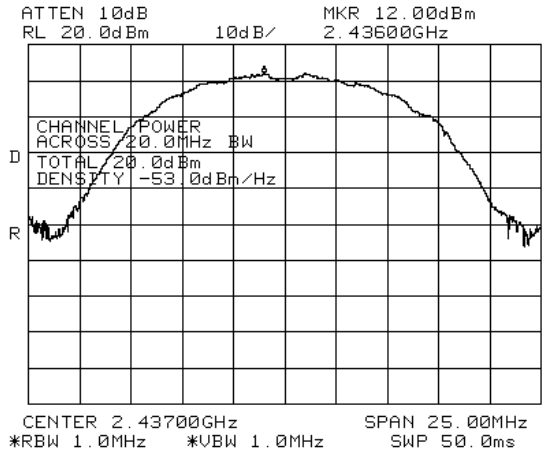

Figure 30 2437 MHz BPSK

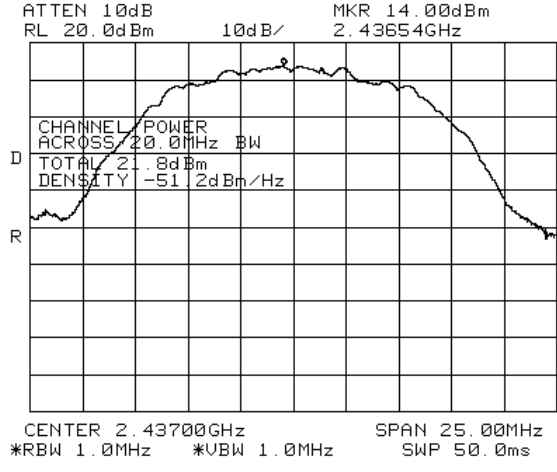

Figure 31 2437 MHz CCK

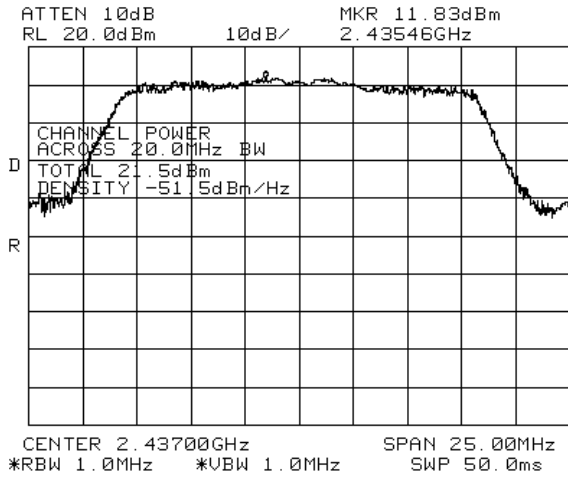

Figure 32 2437 MHz 64QAM

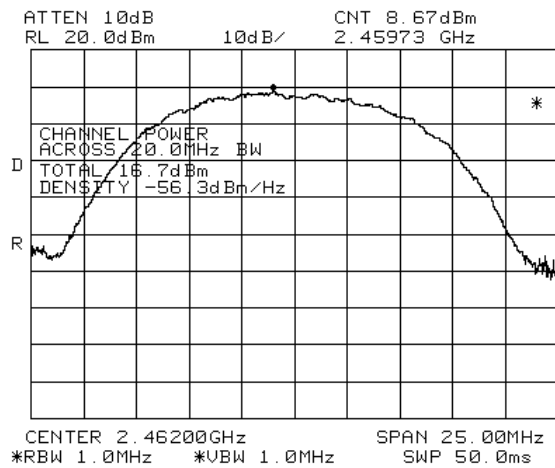

Figure 33 2462 MHz DBPSK

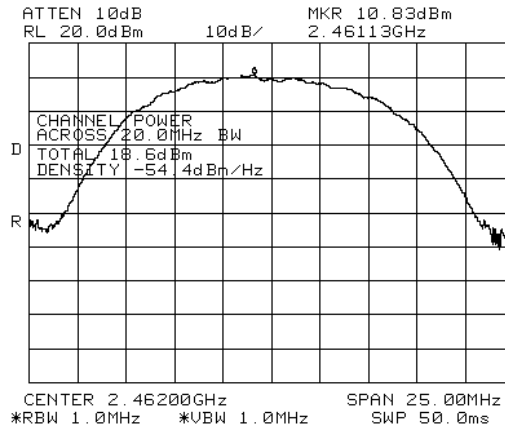

Figure 34 2462 MHz BPSK

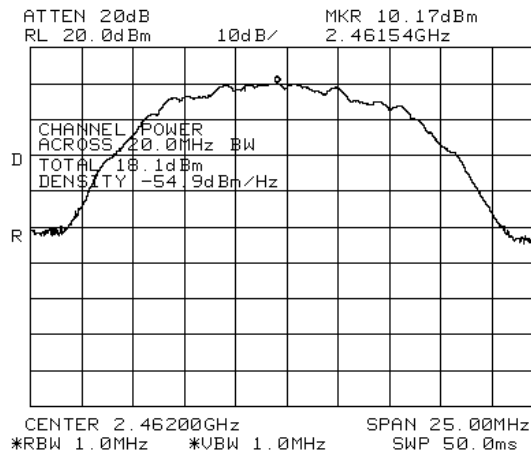

Figure 35 2462 MHz CCK

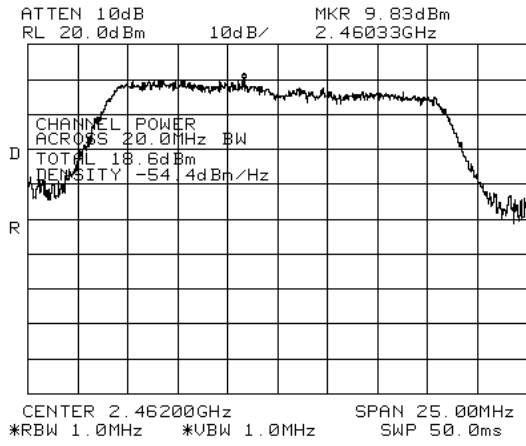

Figure 36 2462 MHz 64QAM

7.2 Results table

E.U.T. Description: WLAN Module With WCE (WiFi Coverage Extender) for DAS
With Four Cisco 1242 Access Points

Model No.: 860M With WCE

Serial Number: 1. 860M: 73903D 2. WCE: 739038

Specification: F.C.C. Part 15, Subpart C

Operation Frequency (MHz)	Modulation	Power (dBm)	Specification (dBm)	Margin (dB)
2412	DBPSK	15.1	29.0	-13.9
	BPSK	16.6	29.0	-12.4
	CCK	16.8	29.0	-12.2
	64QAM	16.8	29.0	-12.2
2437	DBPSK	19.4	29.0	-9.6
	BPSK	20.0	29.0	-9.0
	CCK	21.8	29.0	-7.2
	64QAM	21.5	29.0	-7.5
2462	DBPSK	16.7	29.0	-12.3
	BPSK	18.6	29.0	-10.4
	CCK	18.1	29.0	-10.9
	64QAM	18.6	29.0	-10.4

Figure 37 Maximum Peak Power Output

Note: Antenna Gain is 7 dBi

JUDGEMENT: Passed by 7.2 dB

TEST PERSONNEL:

Tester Signature: 

Date: 05.02.08

Typed/Printed Name: E. Pitt

7.3 Test Equipment Used.

Peak Power Output

Instrument	Manufacturer	Model	Serial/Part Number	Calibration	
				Last Calibr.	Period
Spectrum Analyzer	HP	8564E	3442A00275	November 14, 2007	1 year
Attenuator	Jyebao	-	FAT-AM5AF5G6G2W20	May 9, 2007	1 year
Cable	Rhophase	KPS-5000-KPS	A1674	February 8, 2007	1 year

Figure 38 Test Equipment Used

8. Peak Power Output Out of 2400-2483.5 MHz Band 2.4 GHz Transmitter 802.11 b/g +a Signals

8.1 Test procedure

The E.U.T. antenna terminal was connected to the spectrum analyzer through an external attenuator (20 dB) and an appropriate coaxial cable. The spectrum analyzer was set to 100 kHz resolution BW except for the frequency range 9 kHz-150 kHz where the RBW was set to 1kHz and the frequency range 150 kHz-10 MHz where the RBW was set to 10kHz. The frequency range from 9 kHz to 25 GHz was scanned. Level of spectrum components out of the 2400-2483.5 MHz was measured at the selected operation frequencies.

The E.U.T. was tested at 2412, 2437, and 2462 MHz with the following modulations: DBPSK (1Mbit/sec), BPSK (6Mbit/sec), CCK (11Mbit/sec) and 64QAM (54Mbit/sec).

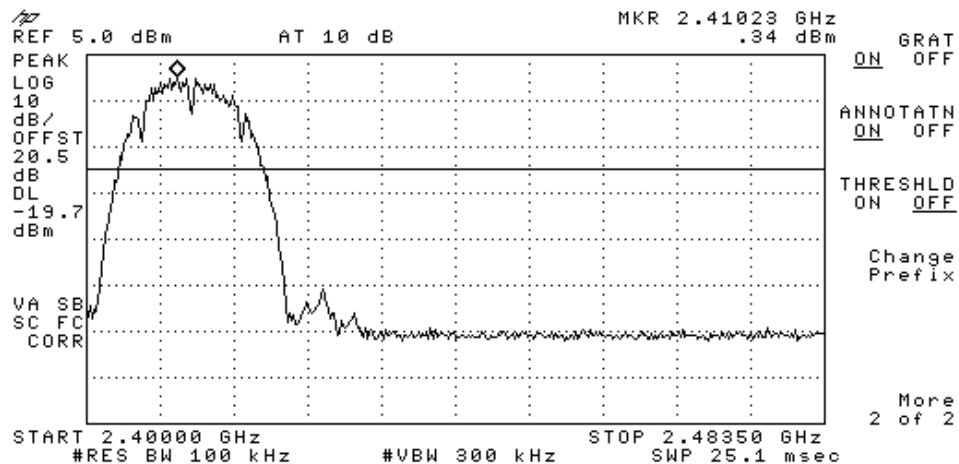

Figure 39 —2412 MHz DBPSK

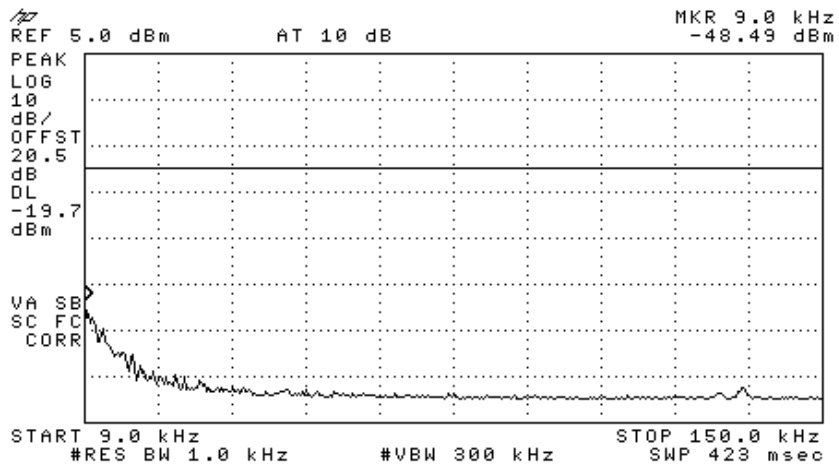

Figure 40 —2412 MHz DBPSK

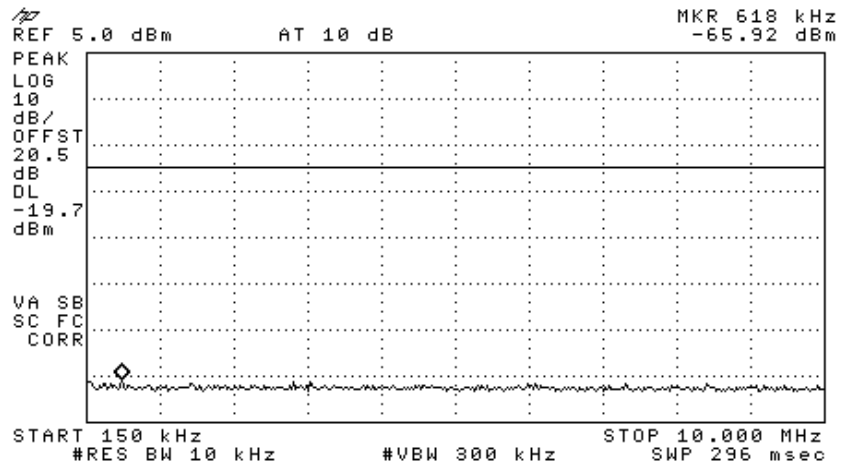

Figure 41 —2412 MHz DBPSK

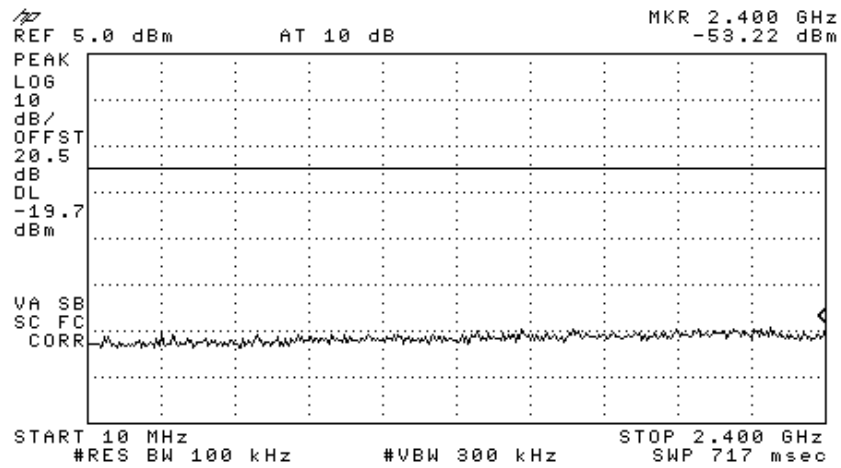

Figure 42 —2412 MHz DBPSK

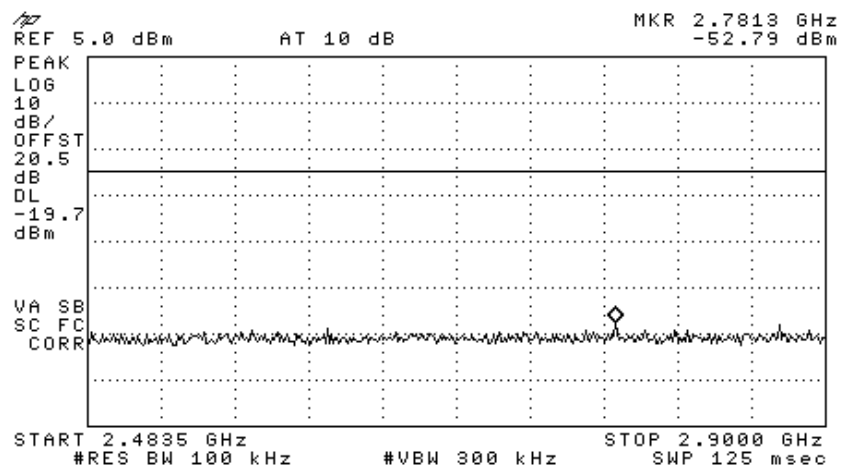

Figure 43 —2412 MHz DBPSK

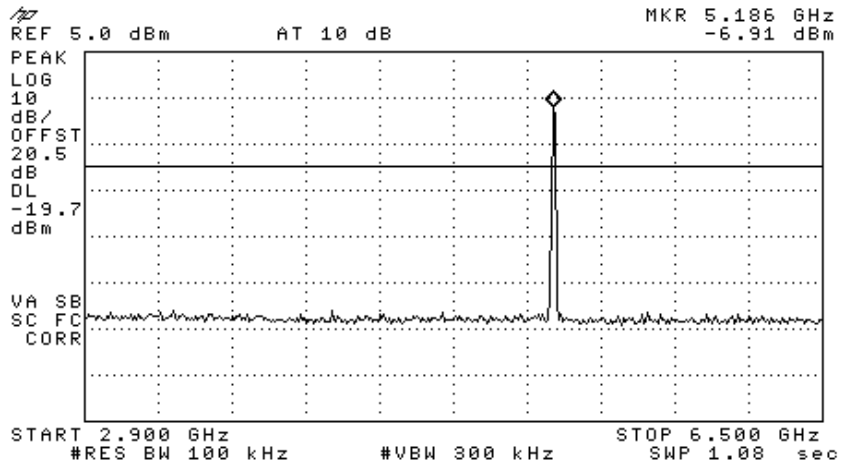

Figure 44 —2412 MHz DBPSK

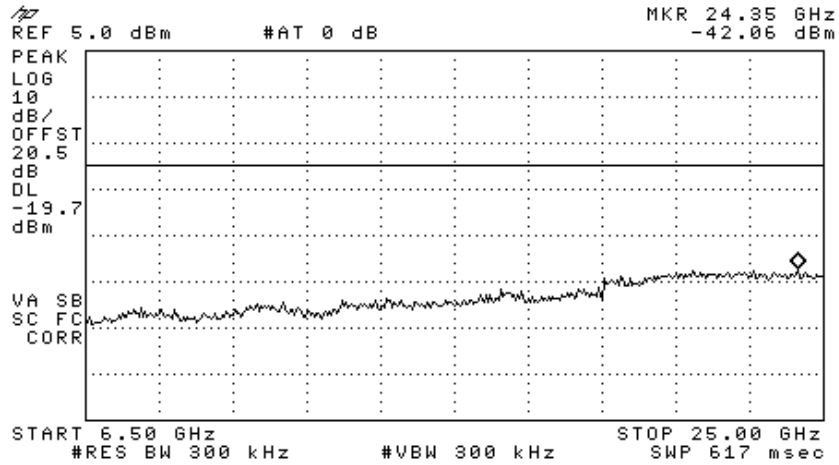

Figure 45 —2412 MHz DBPSK

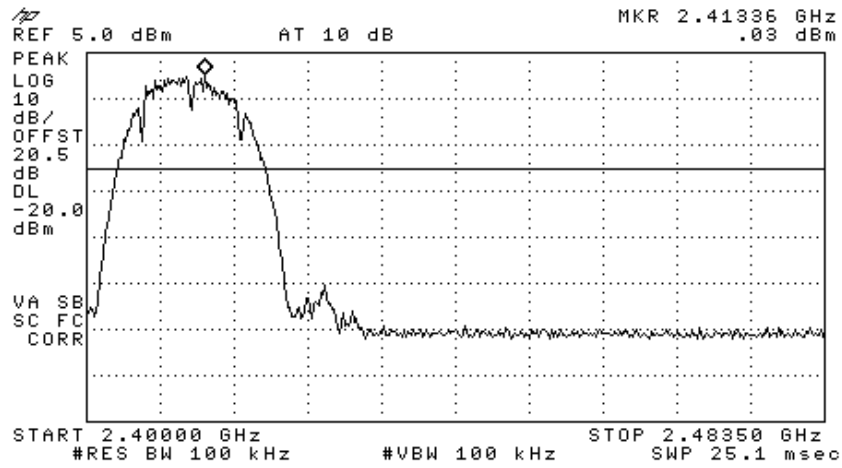

Figure 46 —2412 MHz BPSK

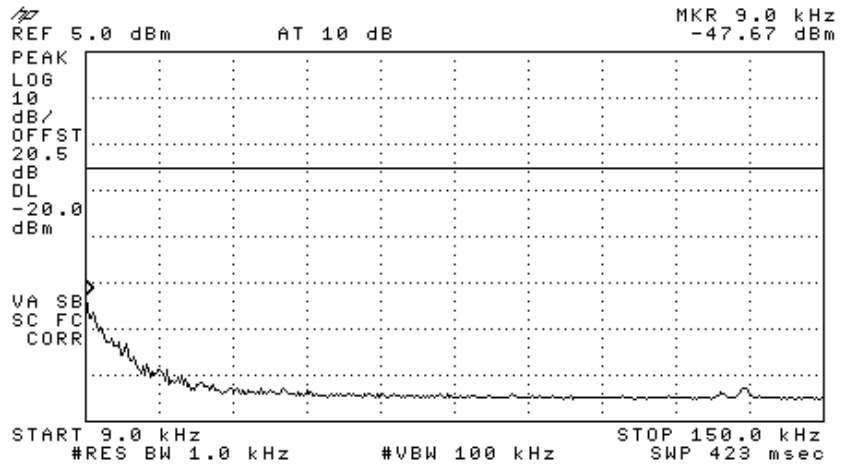

Figure 47 —2412 MHz BPSK

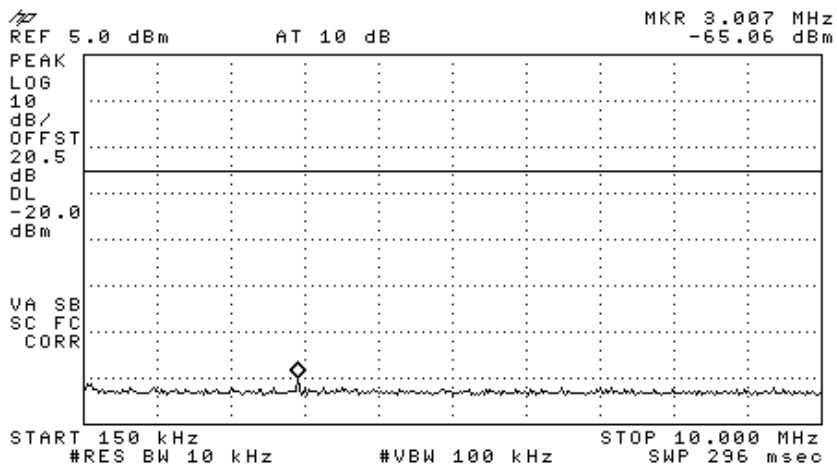

Figure 48 —2412 MHz BPSK

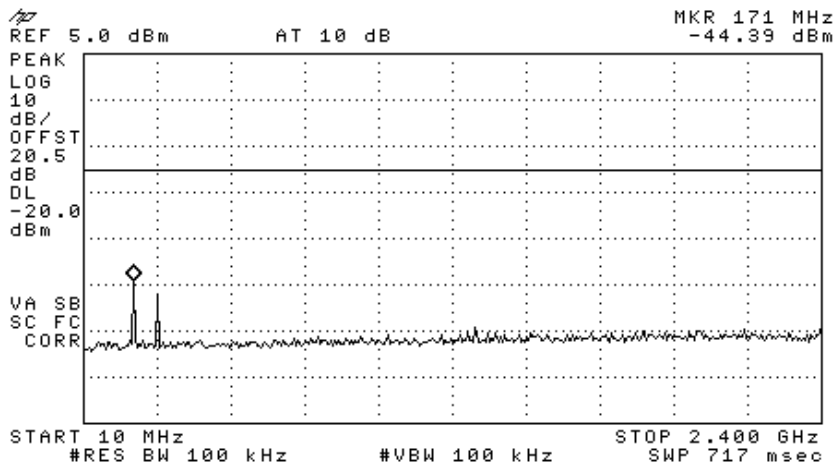

Figure 49 —2412 MHz BPSK

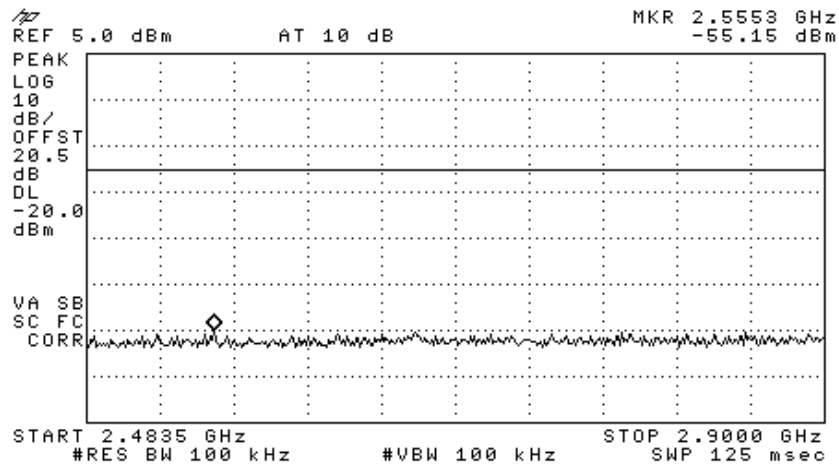

Figure 50 —2412 MHz BPSK

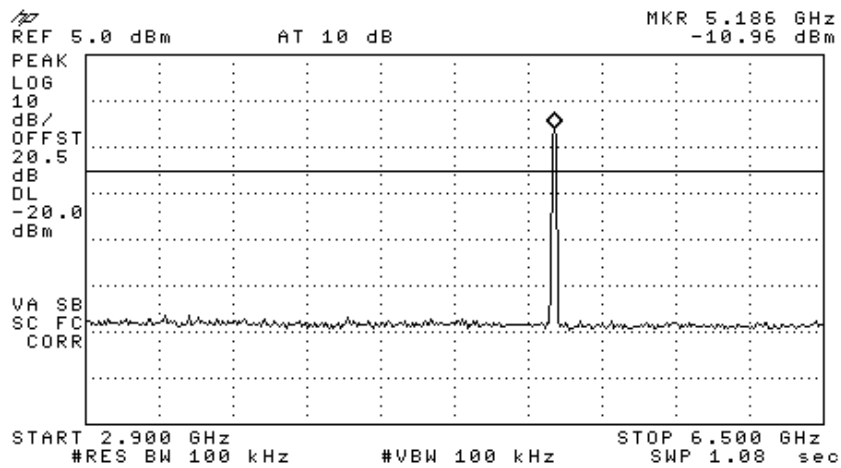

Figure 51 —2412 MHz BPSK

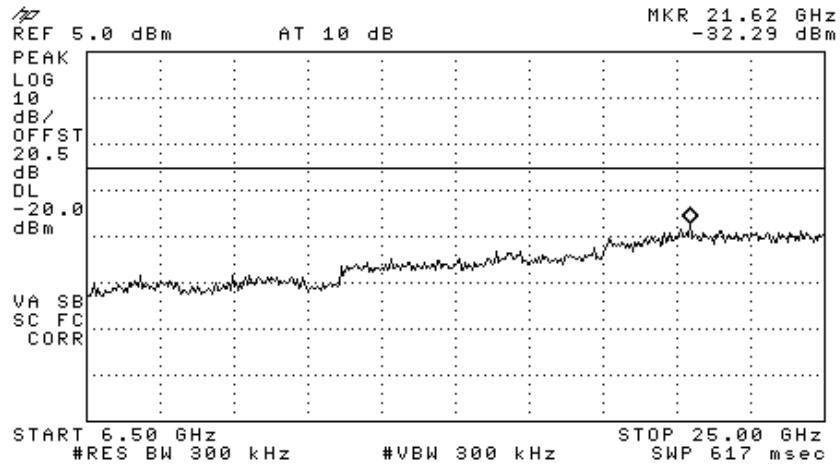

Figure 52 —2412 MHz BPSK

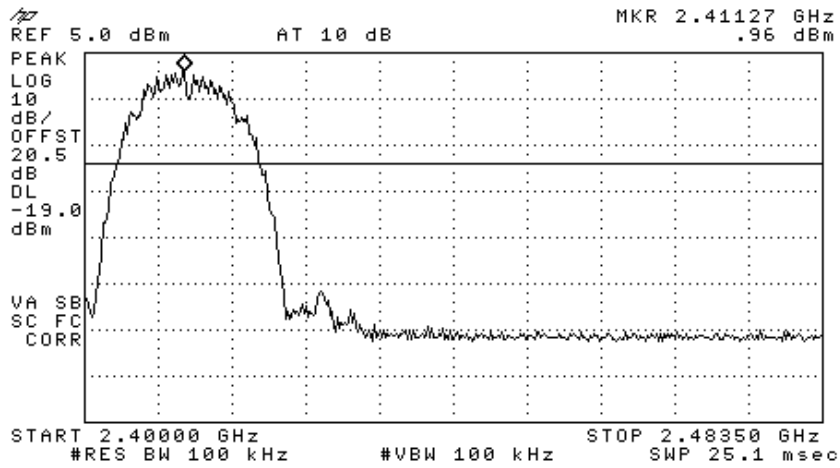

Figure 53 —2412 MHz CCK

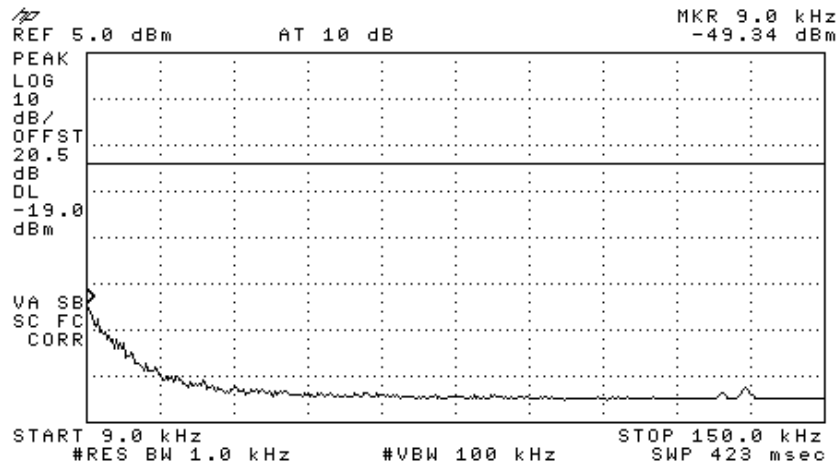

Figure 54 —2412 MHz CCK

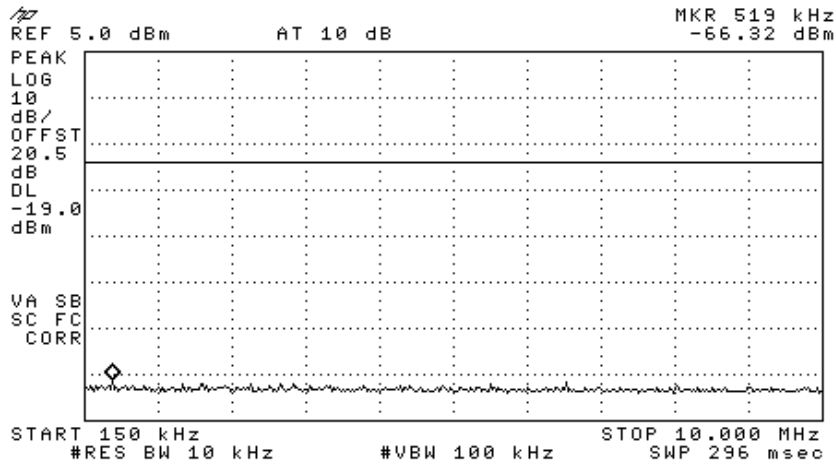

Figure 55 —2412 MHz CCK

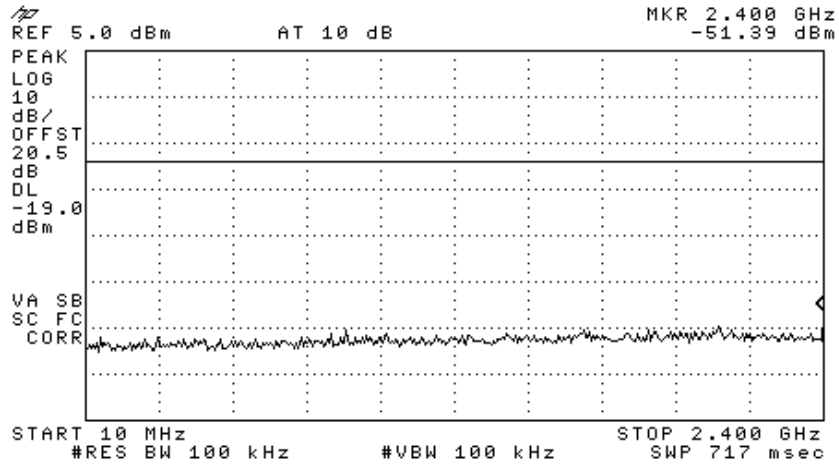

Figure 56 —2412 MHz CCK

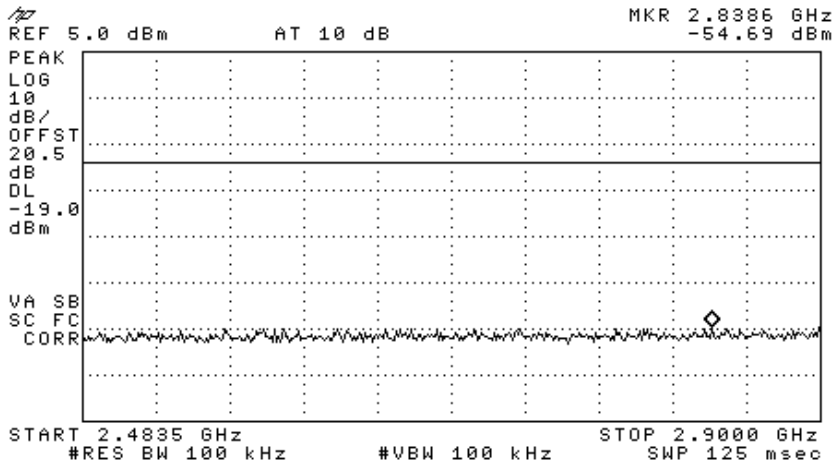

Figure 57 —2412 MHz CCK

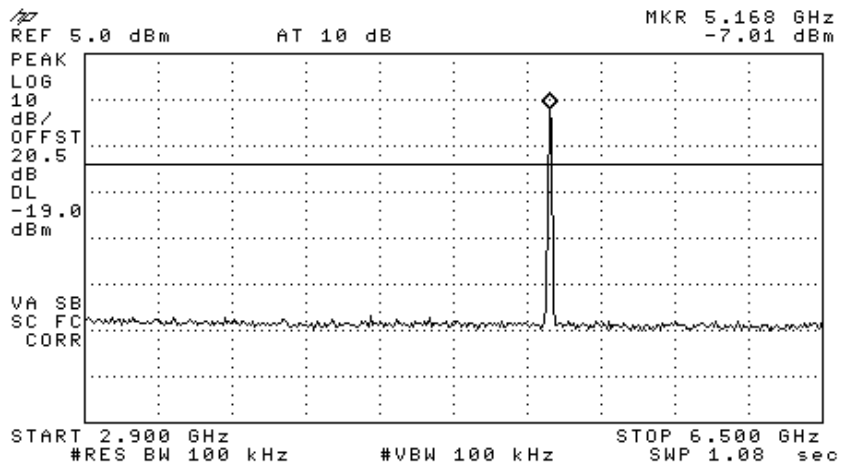

Figure 58 —2412 MHz CCK

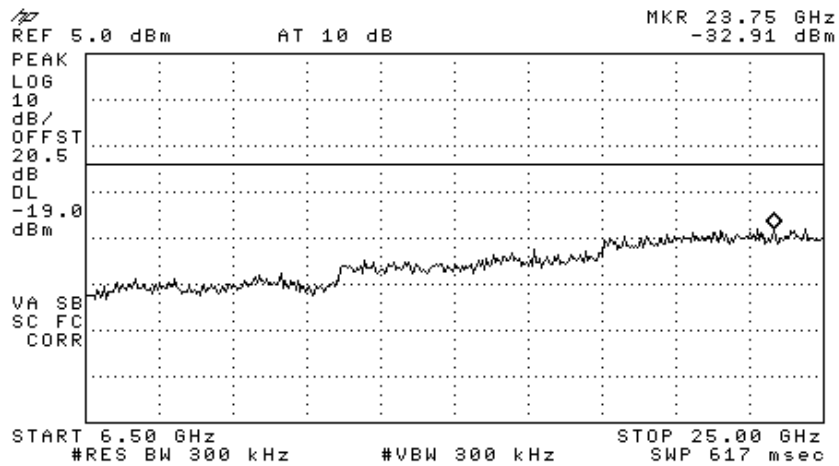

Figure 59 —2412 MHz CCK

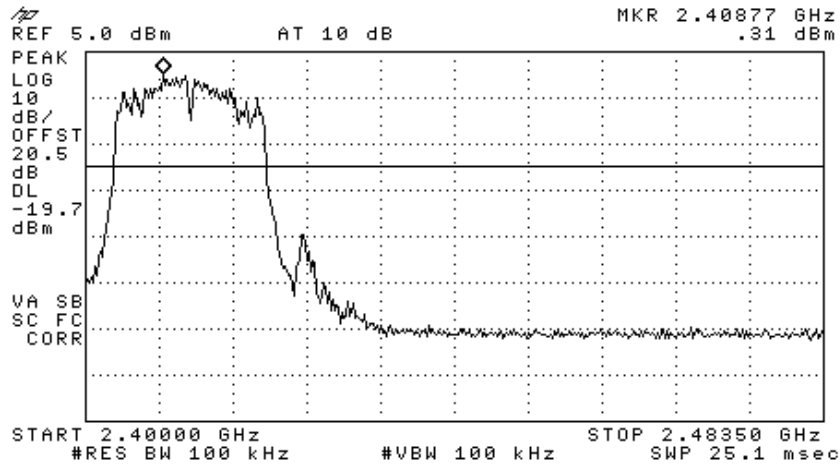

Figure 60 —2412 MHz 64QAM

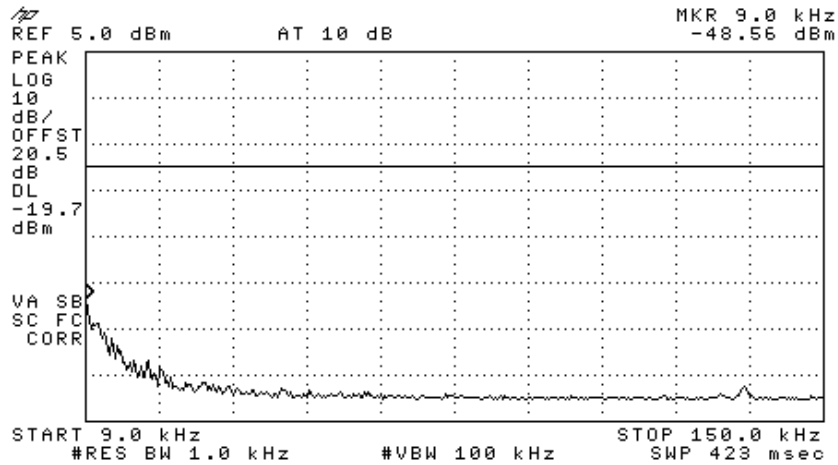

Figure 61 —2412 MHz 64QAM

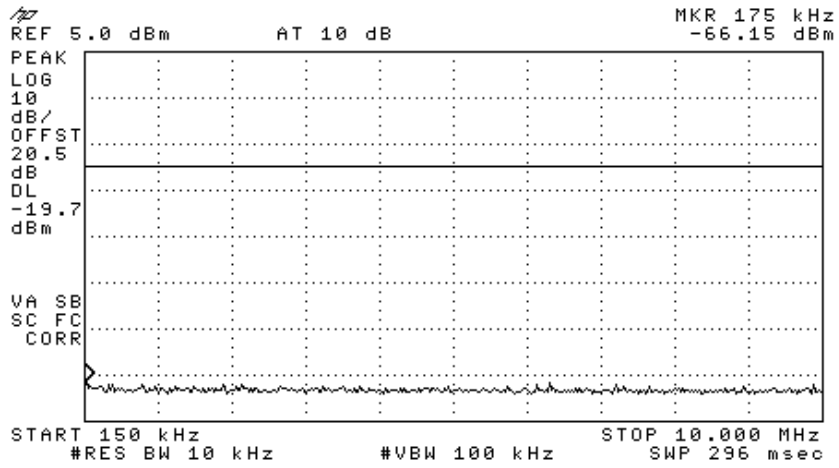

Figure 62 —2412 MHz 64QAM

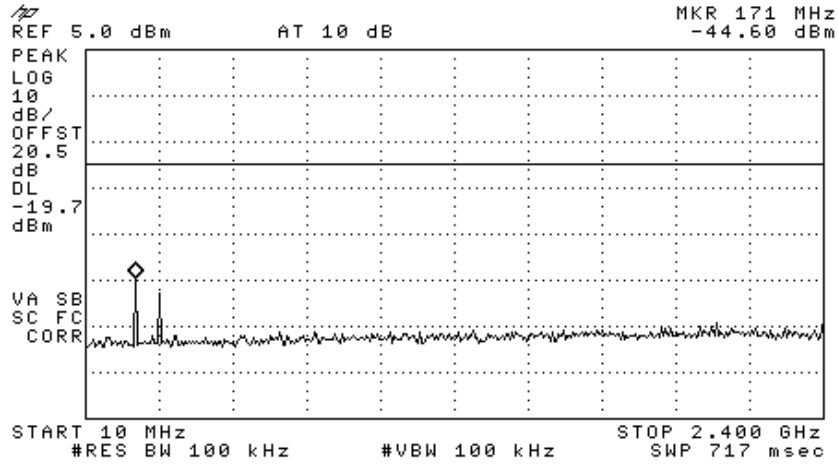

Figure 63 —2412 MHz 64QAM

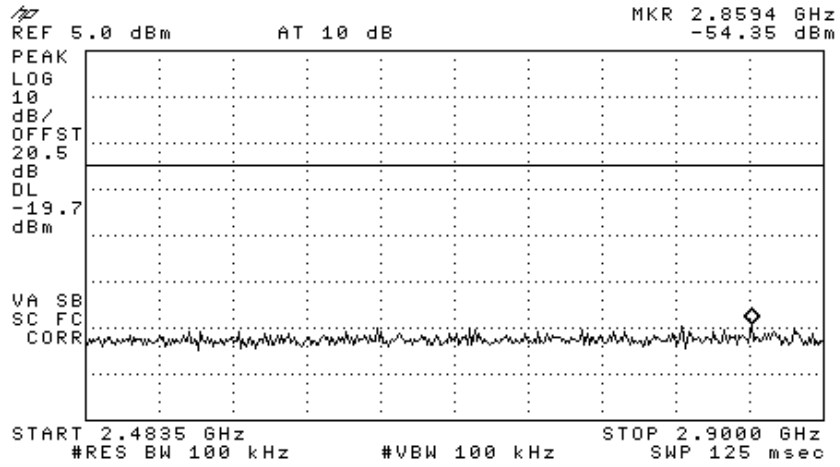

Figure 64 —2412 MHz 64QAM

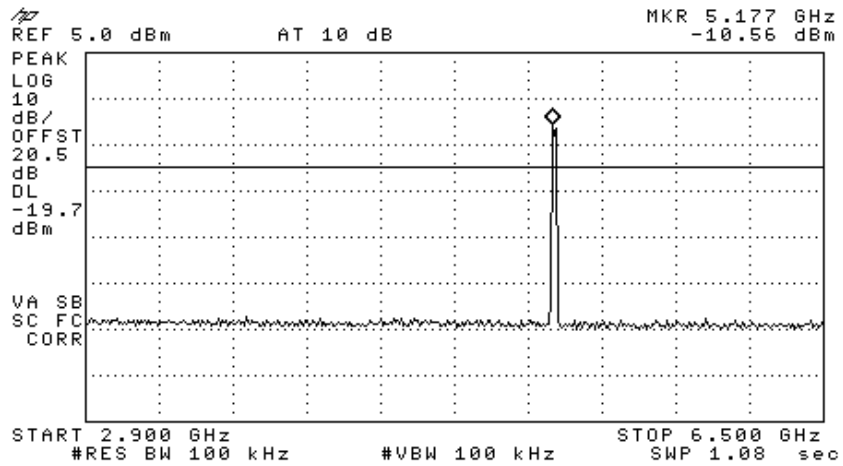

Figure 65 —2412 MHz 64QAM

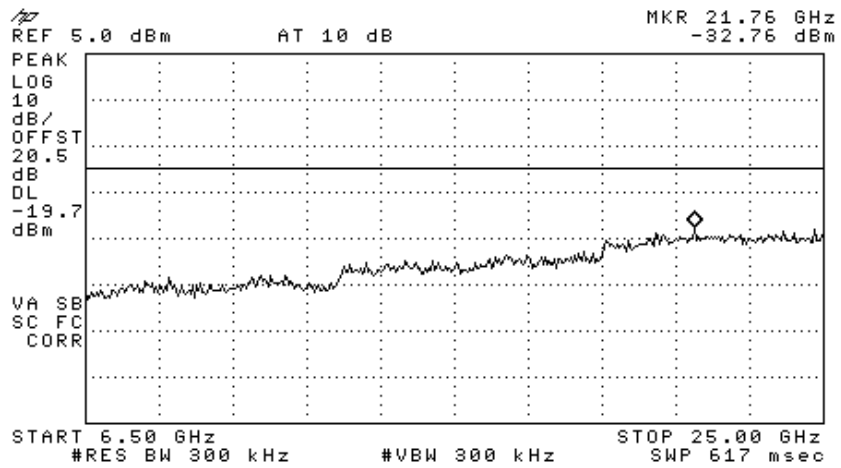

Figure 66 —2412 MHz 64QAM

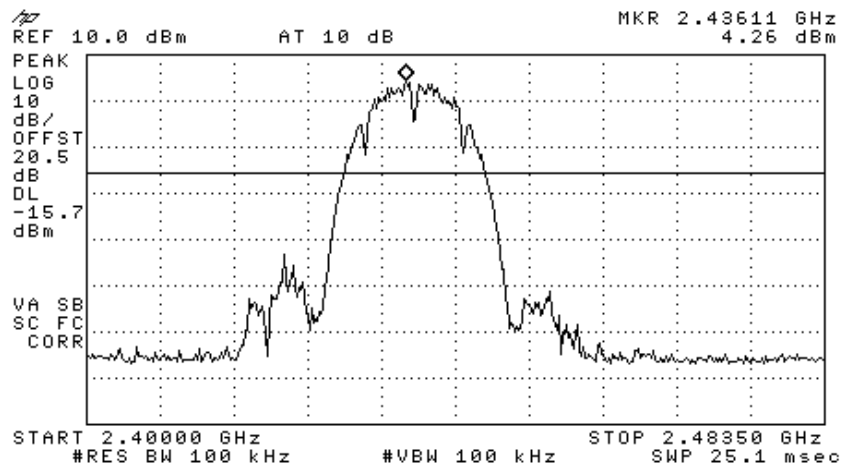

Figure 67 —2437 MHz DBPSK

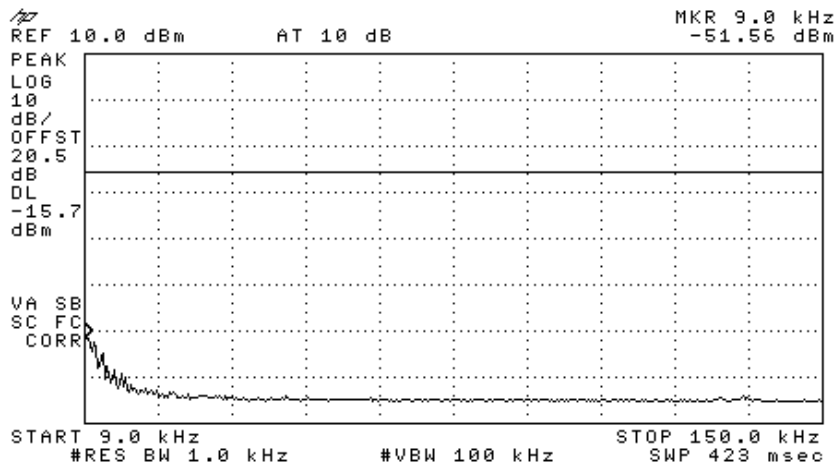

Figure 68 — 2437 MHz DBPSK

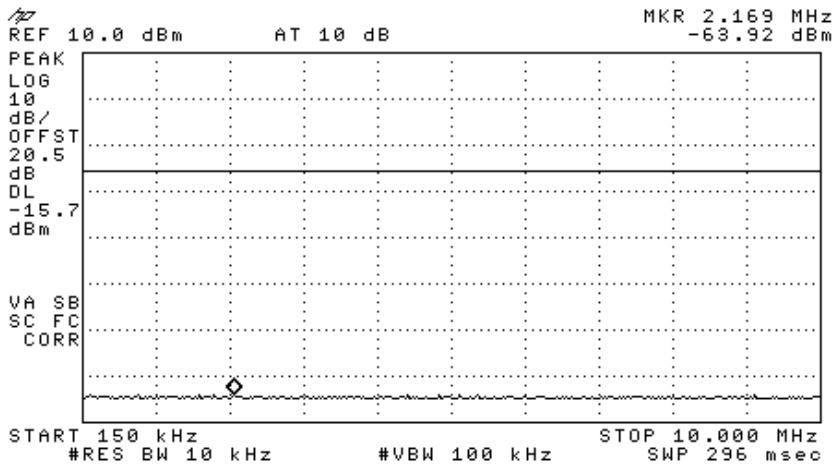

Figure 69 — 2437 MHz DBPSK

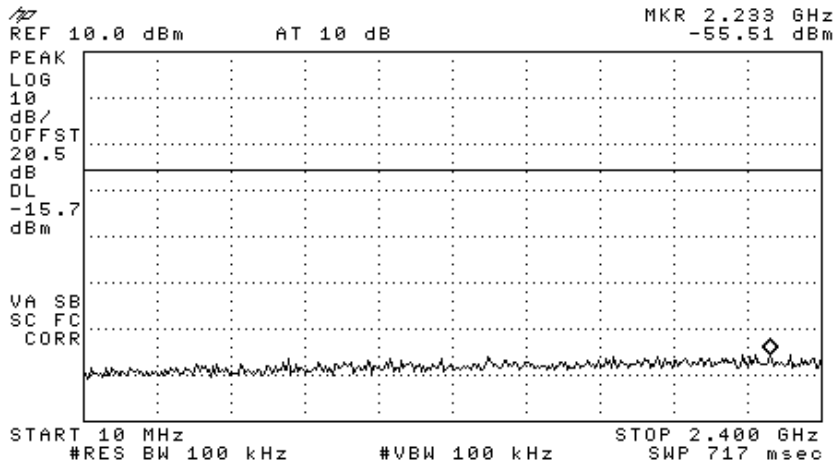

Figure 70 —2437 MHz DBPSK

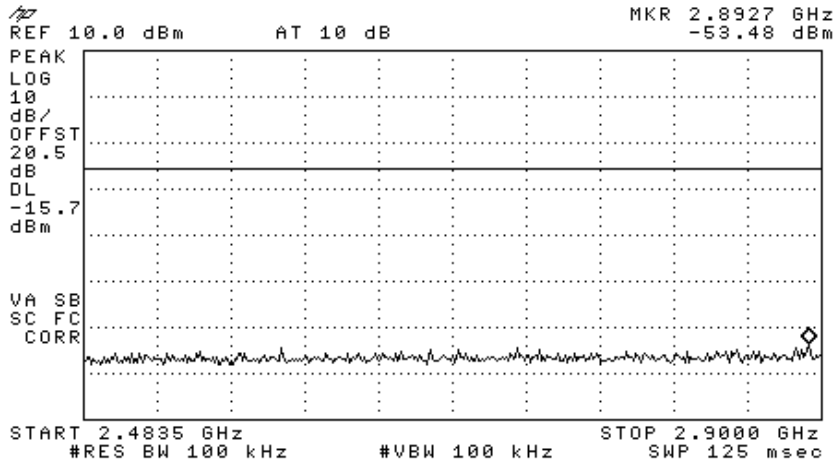

Figure 71 —2437 MHz DBPSK

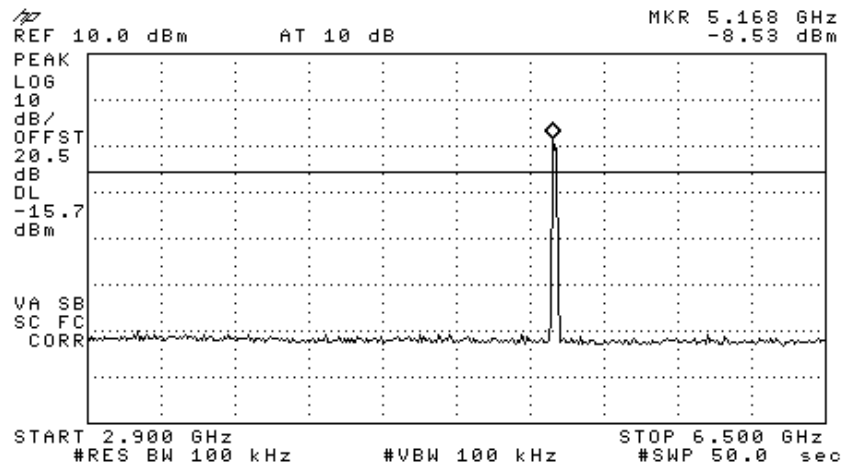

Figure 72 —2437 MHz DBPSK

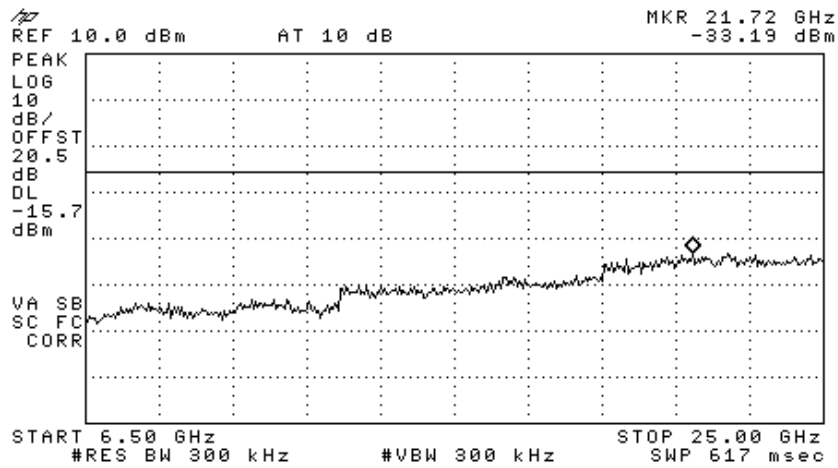

Figure 73 —2437 MHz DBPSK

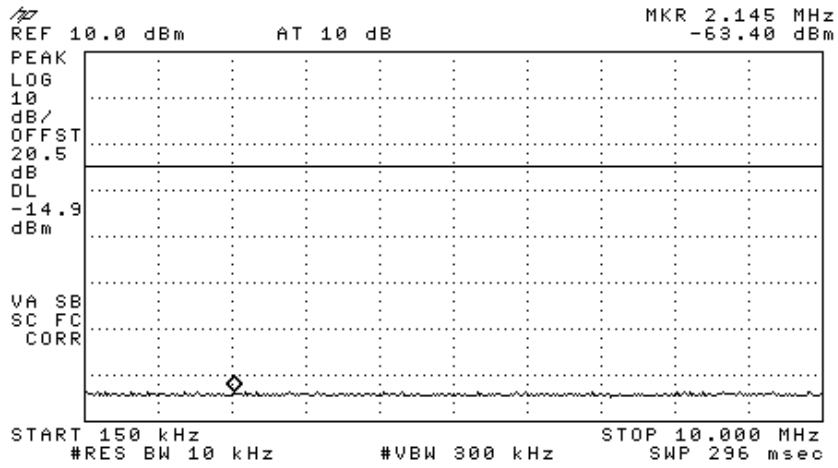

Figure 76 —2437 MHz BPSK

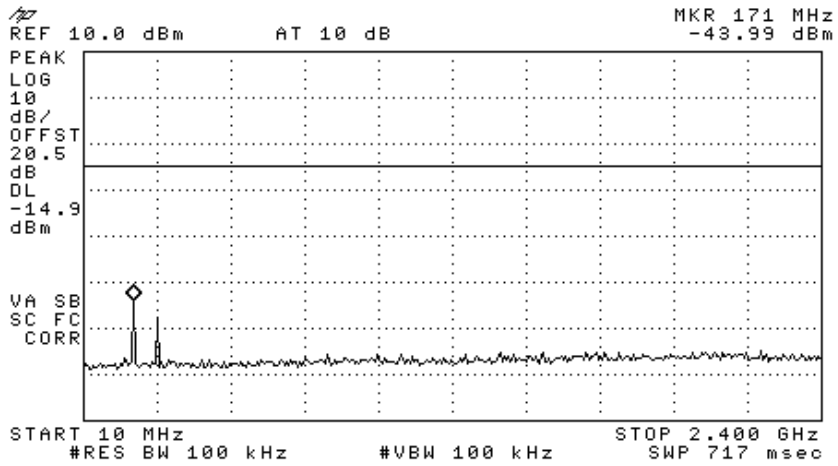

Figure 77 —2437 MHz BPSK

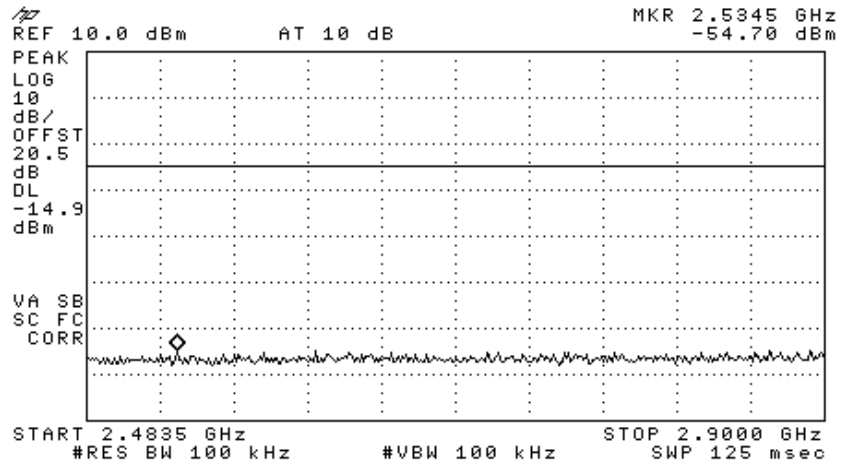

Figure 78 —2437 MHz BPSK

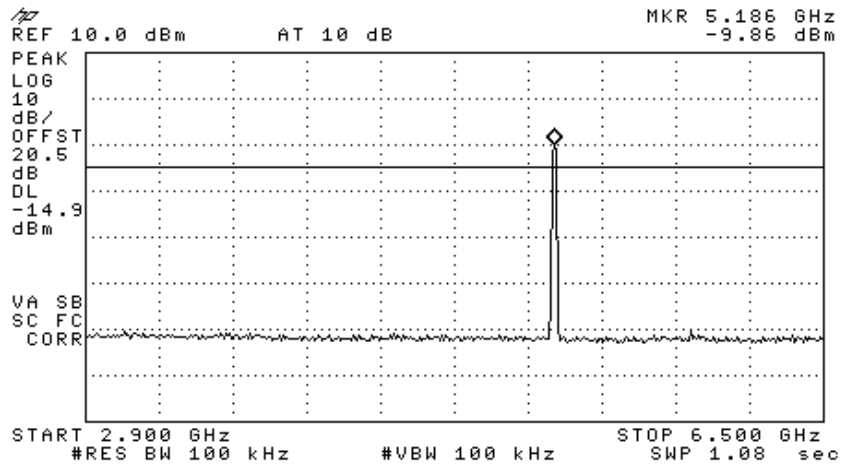

Figure 79 —2437 MHz BPSK

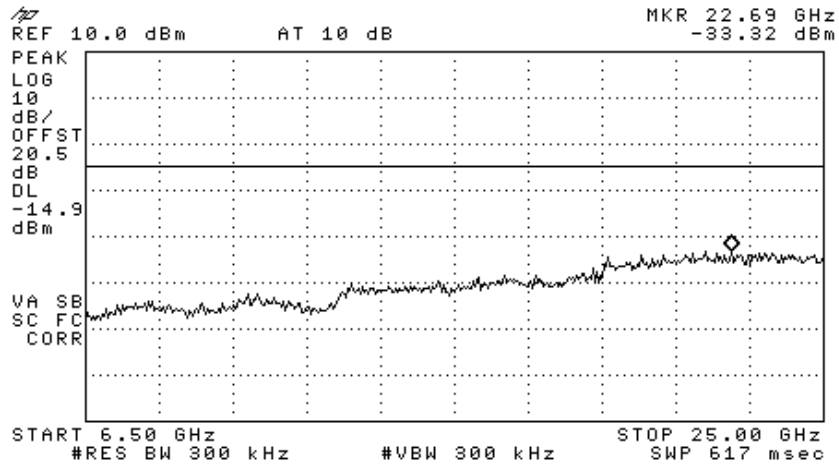

Figure 80 —2437 MHz BPSK

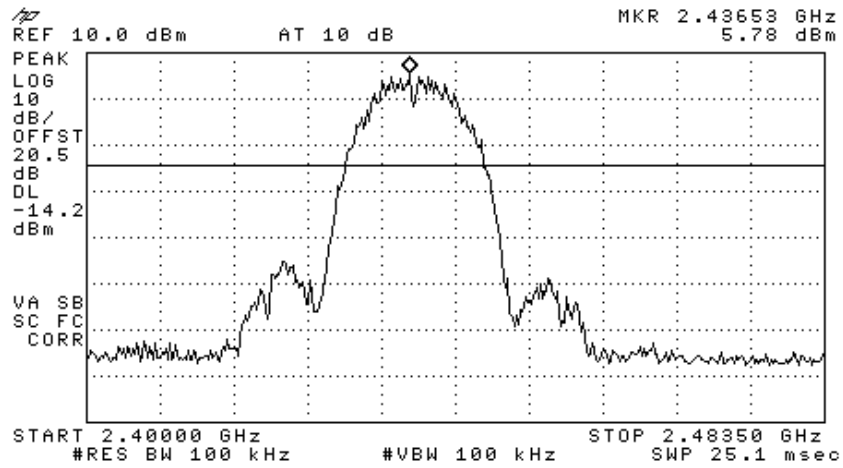

Figure 81 —2437 MHz CCK

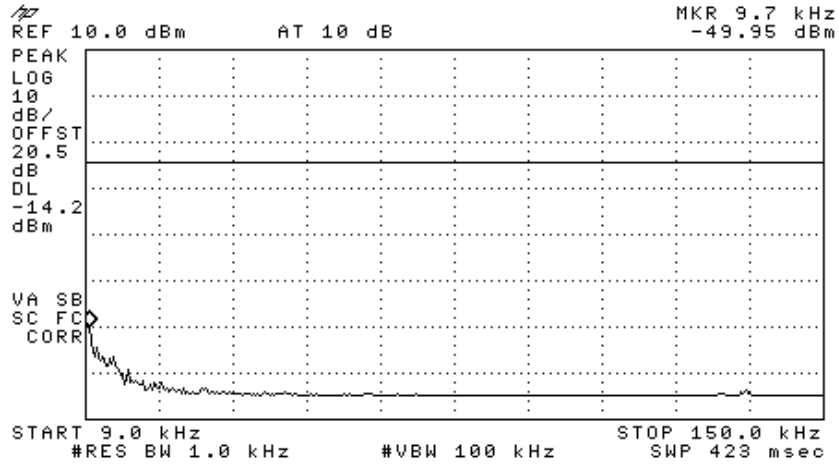

Figure 82 —2437 MHz CCK

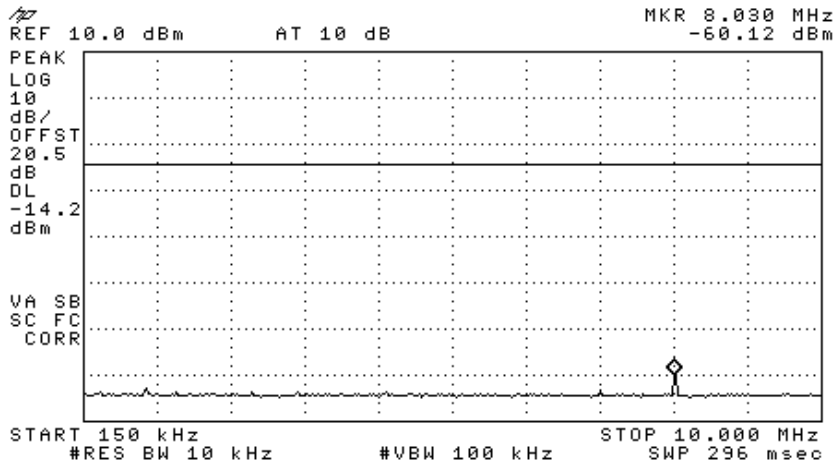

Figure 83 —2437 MHz CCK

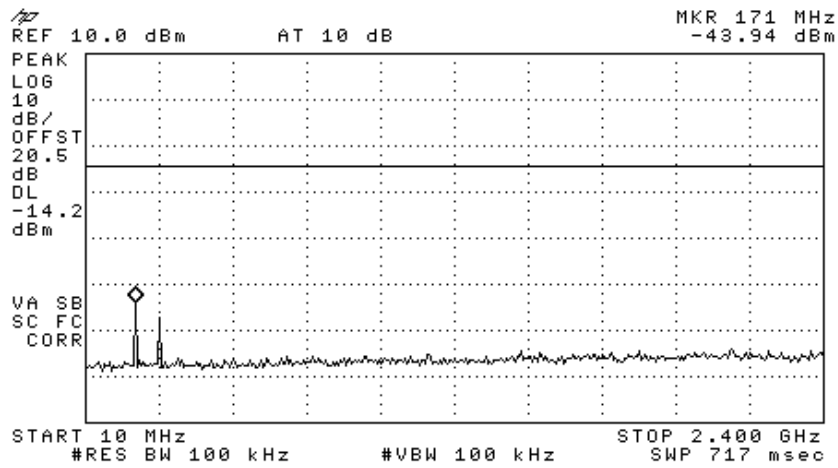

Figure 84 —2437 MHz CCK

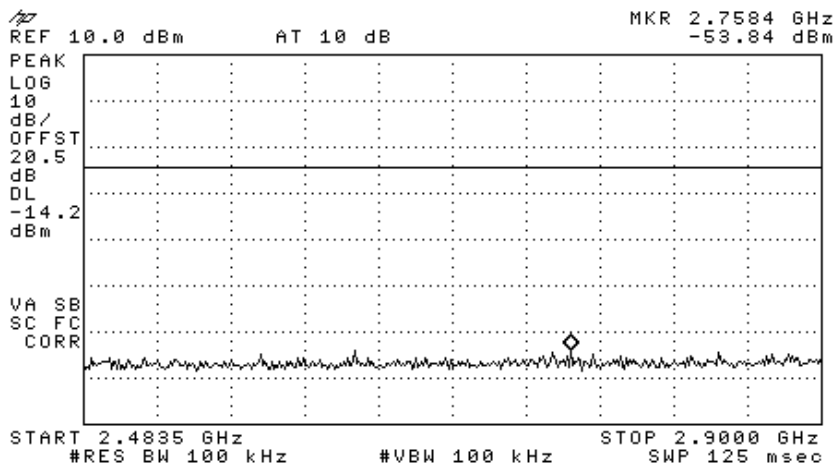

Figure 85 —2437 MHz CCK

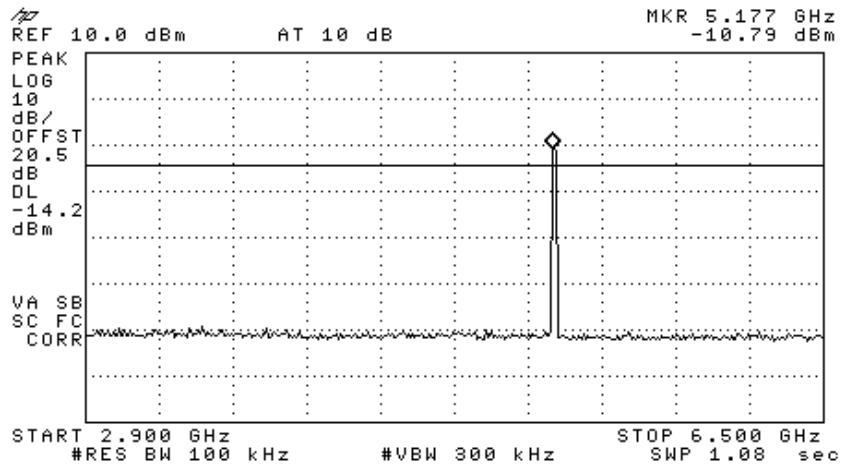

Figure 86 —2437 MHz CCK

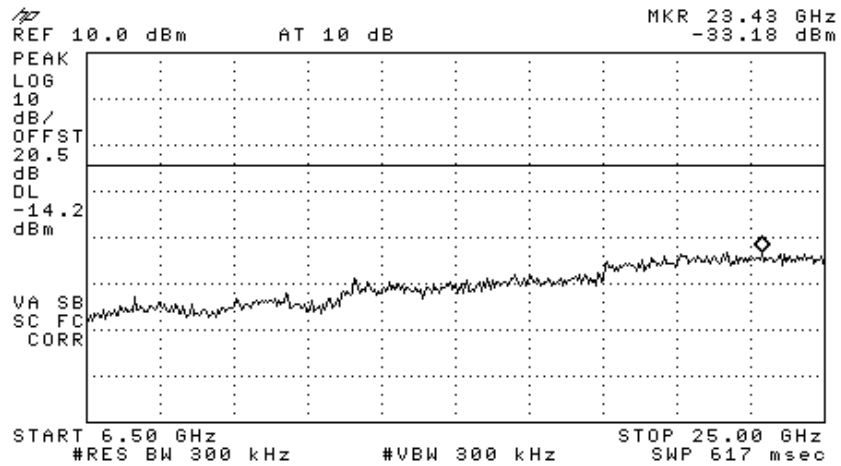

Figure 87 —2437 MHz CCK

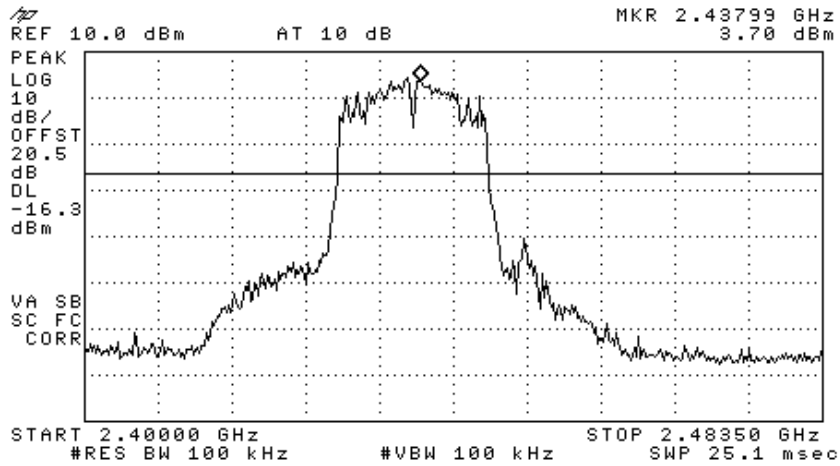

Figure 88 —2437 MHz 64QAM

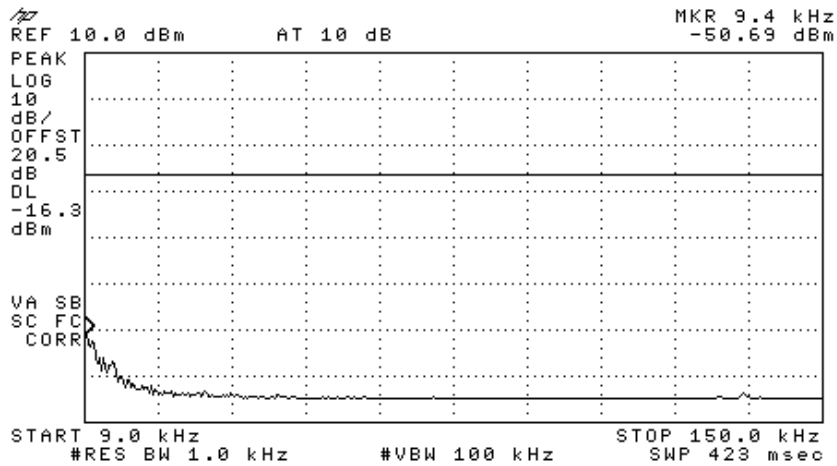

Figure 89 —2437 MHz 64QAM

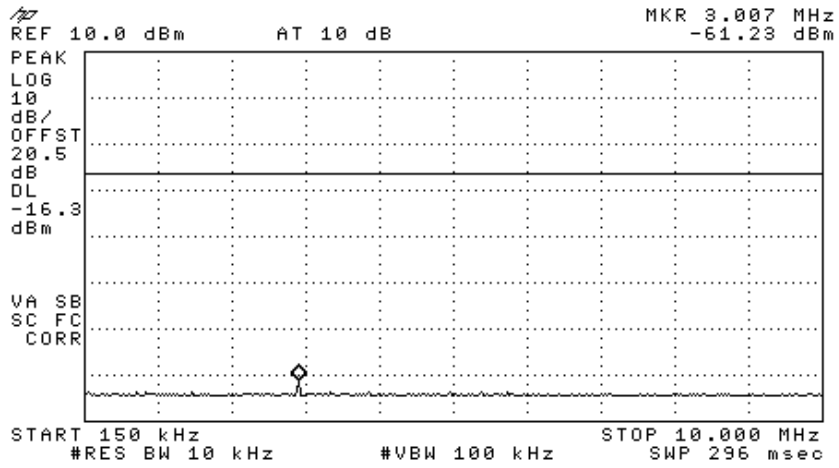

Figure 90 —2437 MHz 64QAM

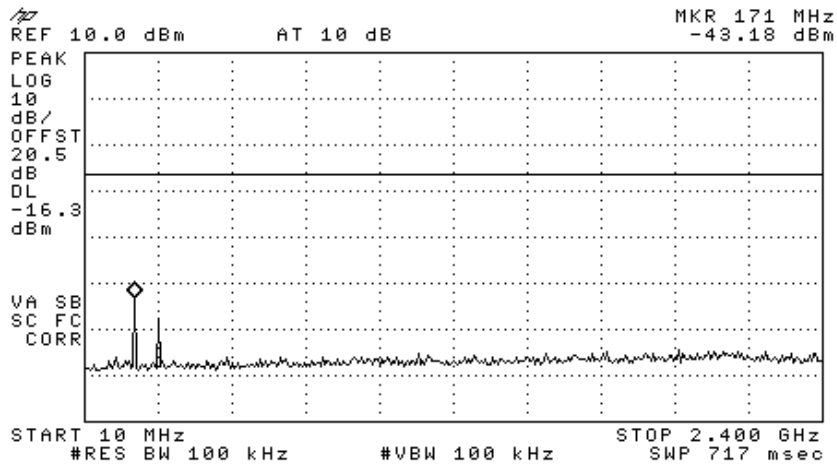

Figure 91 —2437 MHz 64QAM

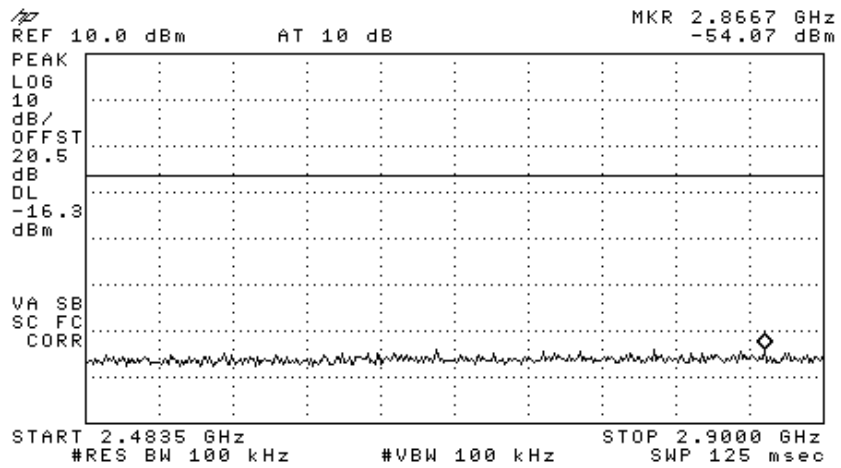

Figure 92 —2437 MHz 64QAM

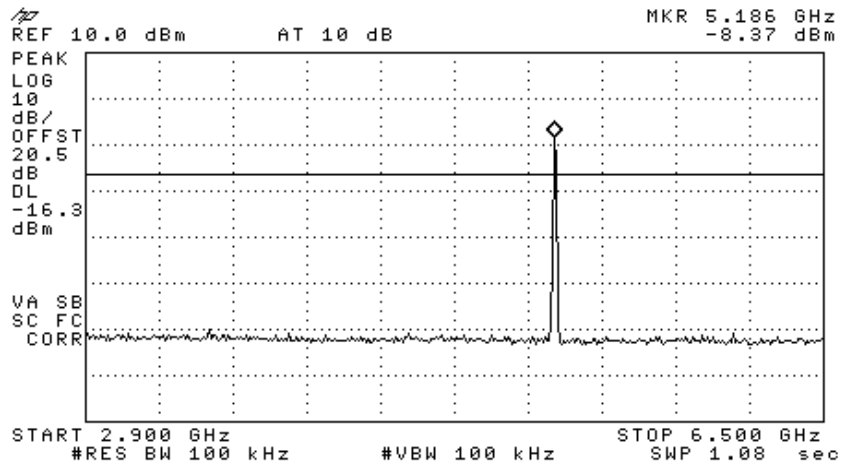

Figure 93 —2437 MHz 64QAM

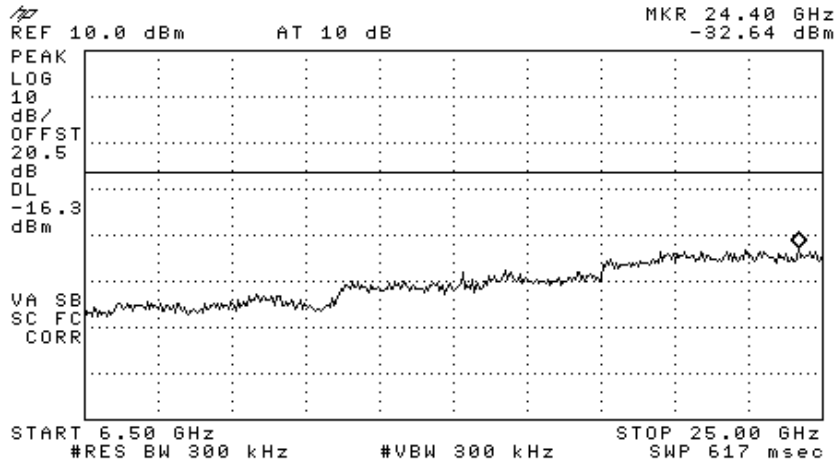

Figure 94 —2437 MHz 64QAM

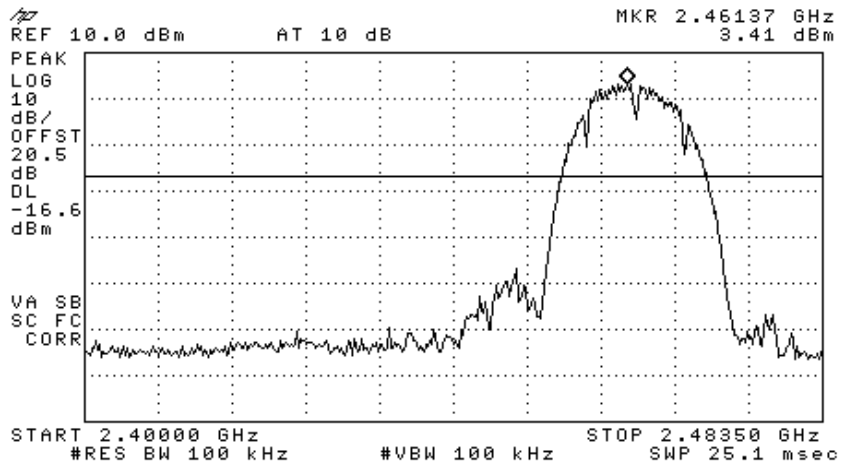

Figure 95 —2462 MHz DBPSK

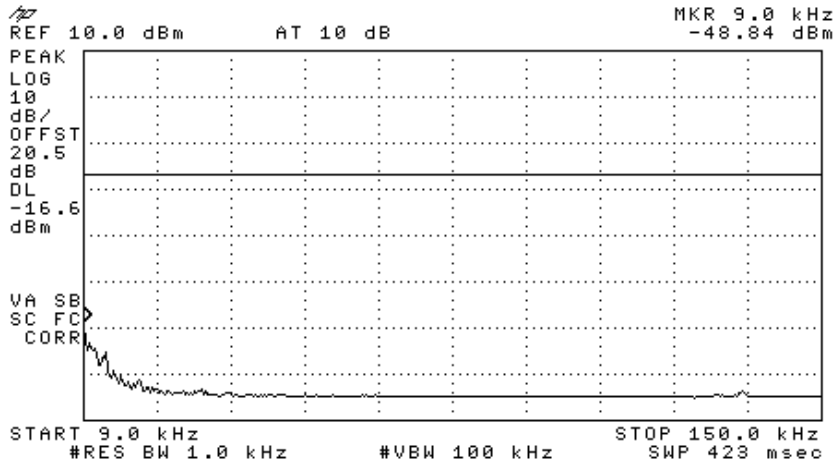

Figure 96 — 2462 MHz DBPSK

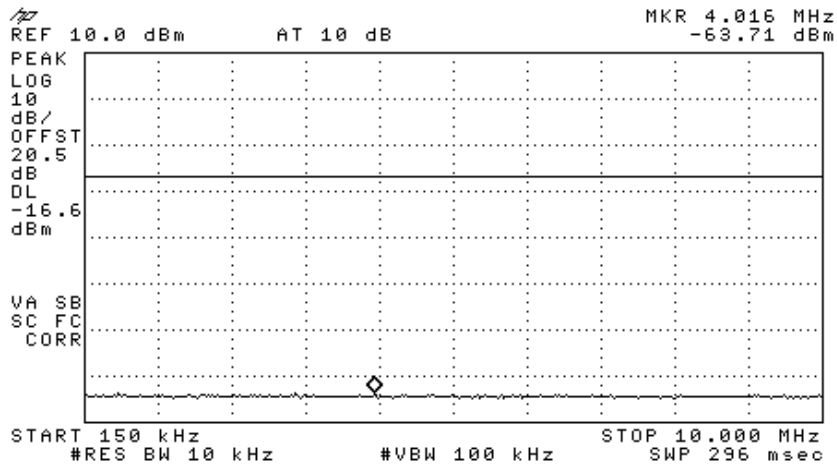

Figure 97 — 2462 MHz DBPSK

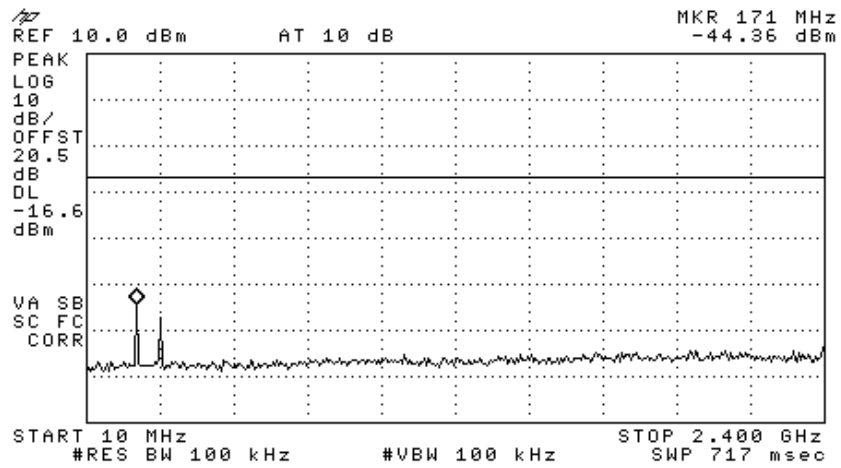

Figure 98 —2462 MHz DBPSK

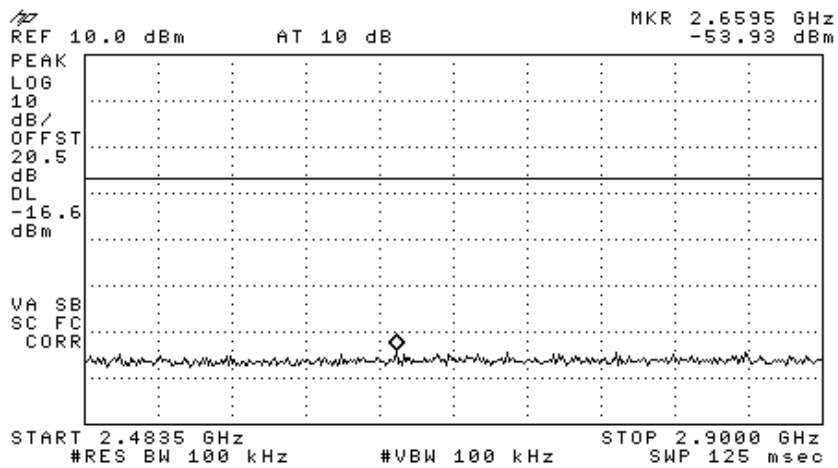

Figure 99 —2462 MHz DBPSK

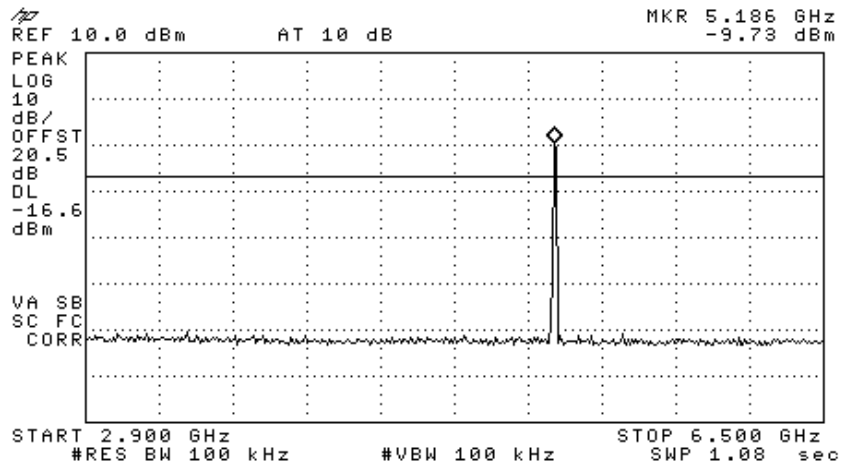

Figure 100 —2462 MHz DBPSK

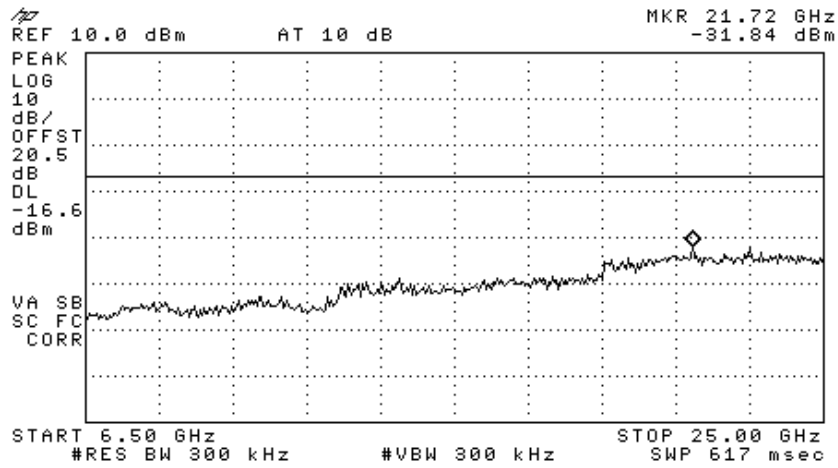

Figure 101 —2462 MHz DBPSK

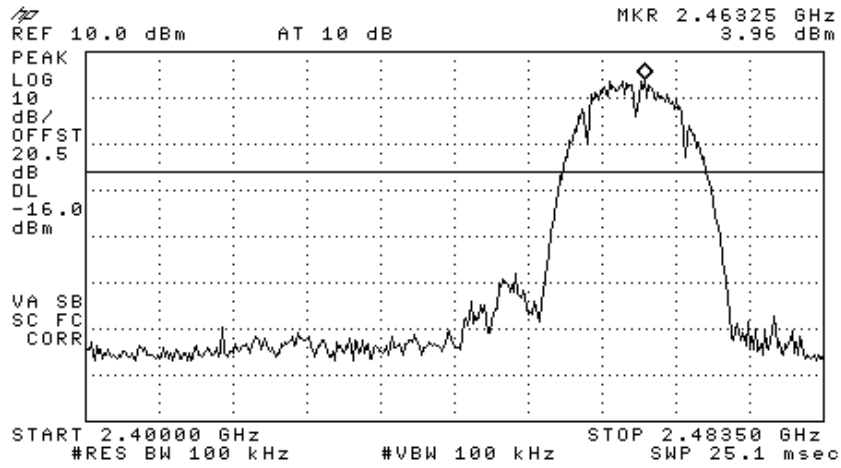

Figure 102 —2462 MHz BPSK

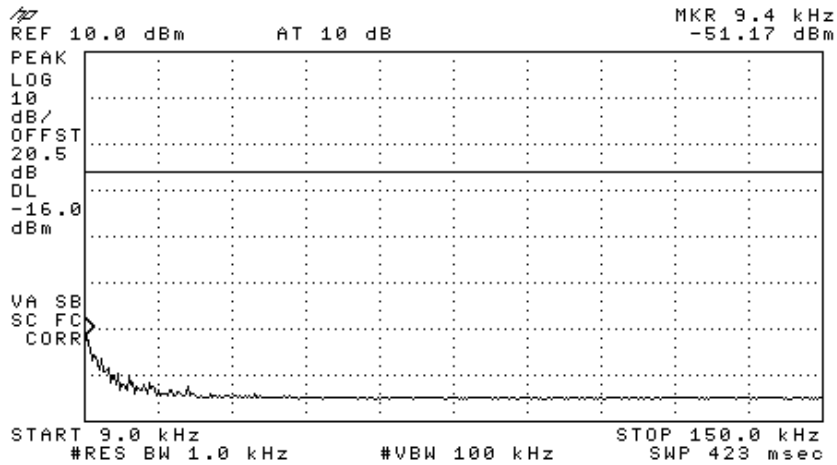

Figure 103 —2462 MHz BPSK

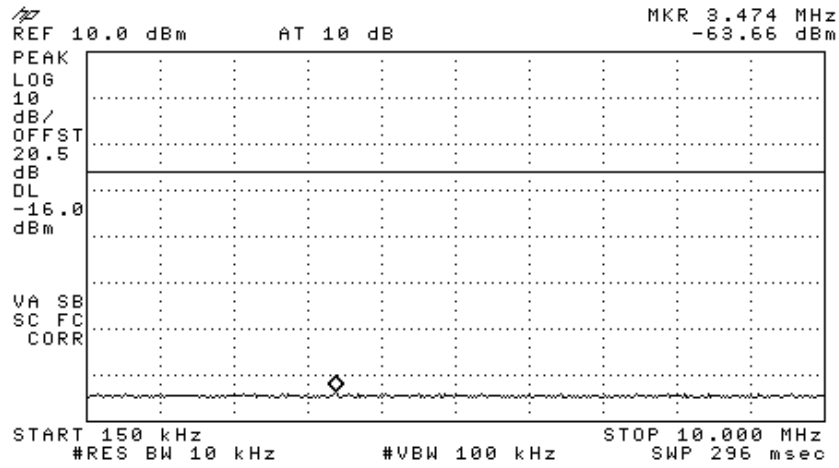

Figure 104 —2462 MHz BPSK

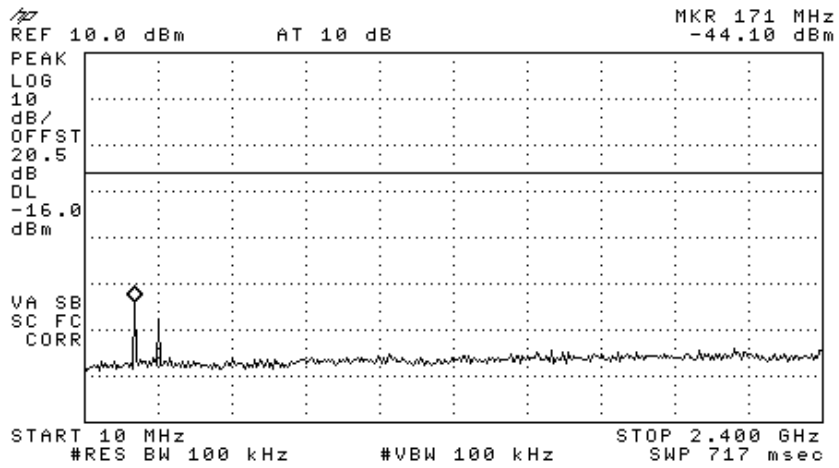

Figure 105 —2462 MHz BPSK

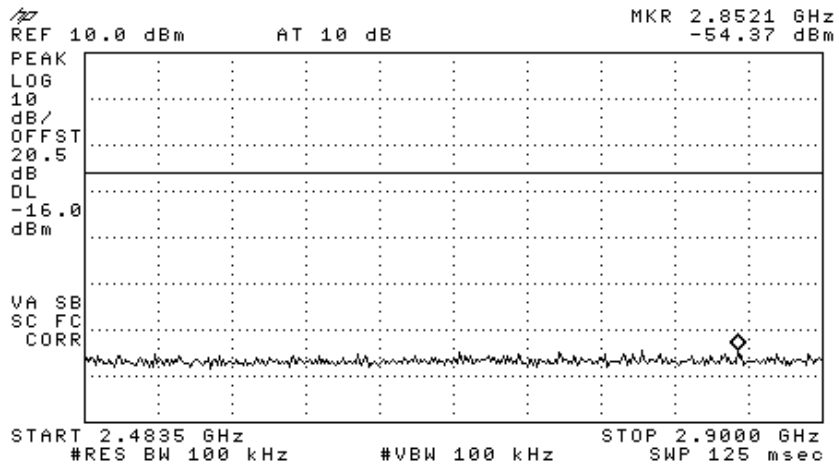

Figure 106 —2462 MHz BPSK

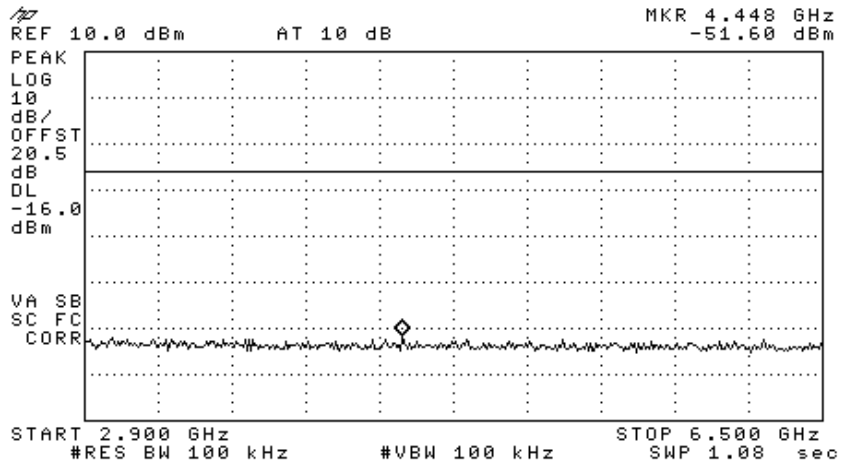

Figure 107 —2462 MHz BPSK

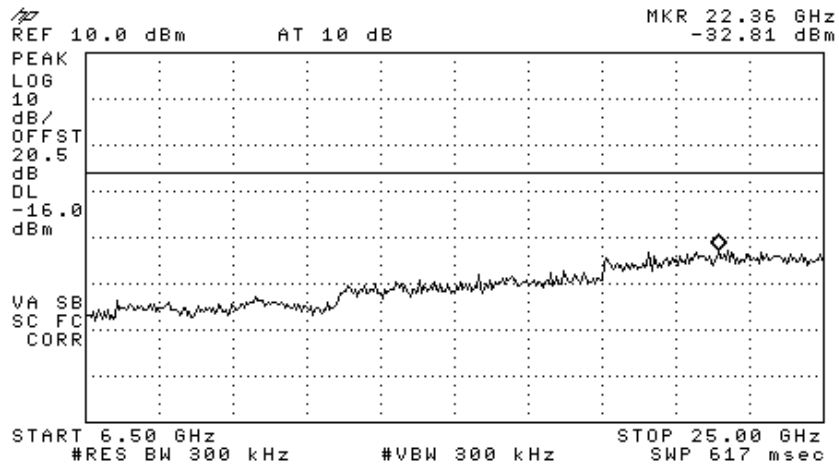

Figure 108 —2462 MHz BPSK

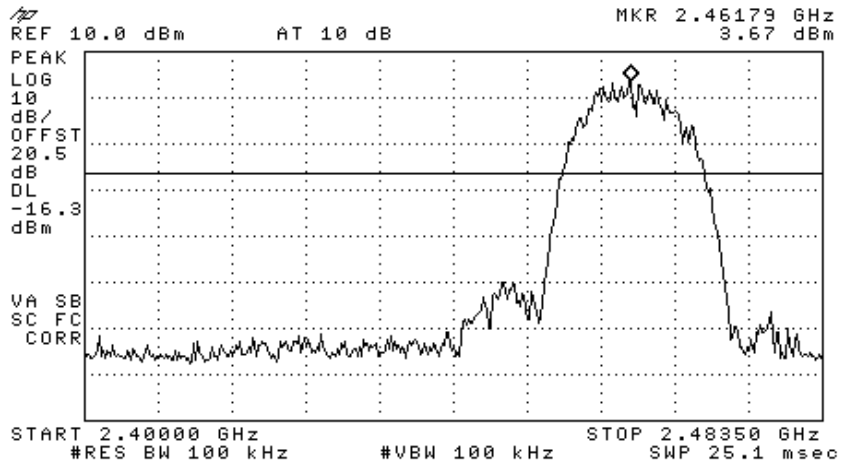

Figure 109 —2462 MHz CCK

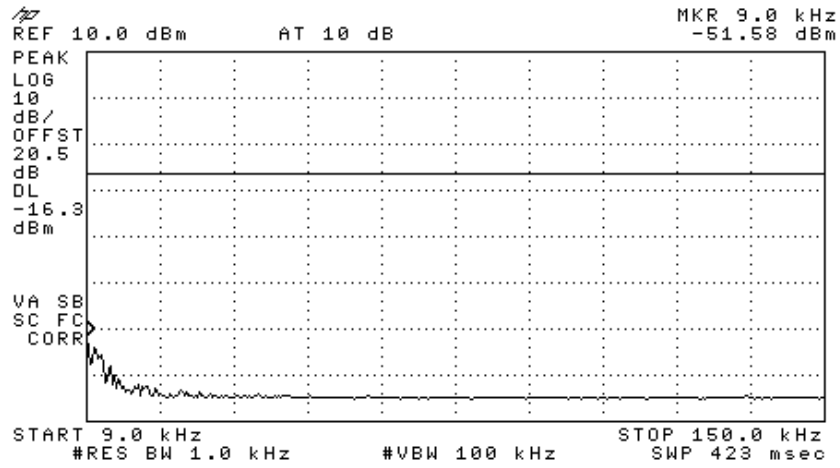

Figure 110 —2462 MHz CCK

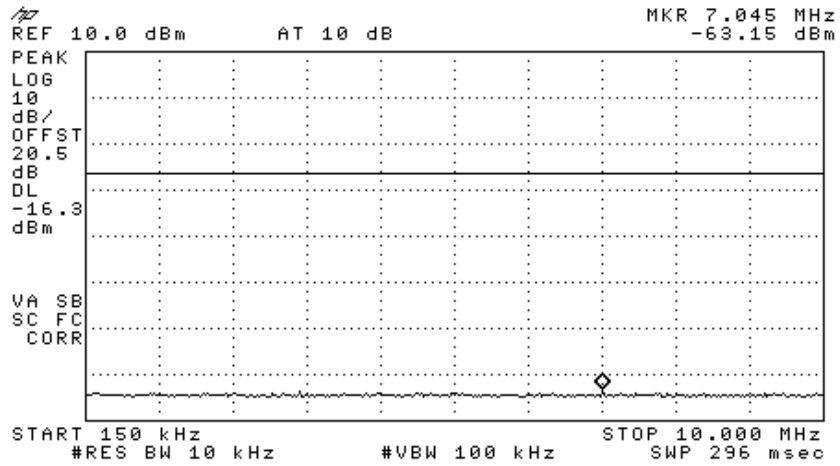

Figure 111 —2462 MHz CCK

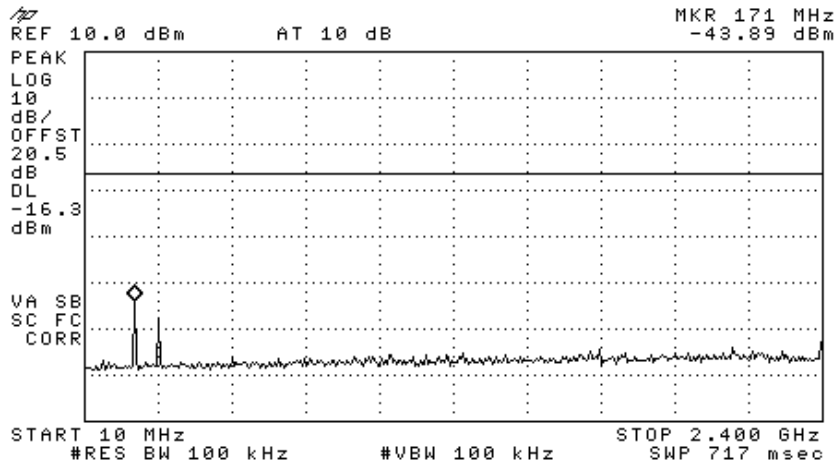

Figure 112 —2462 MHz CCK

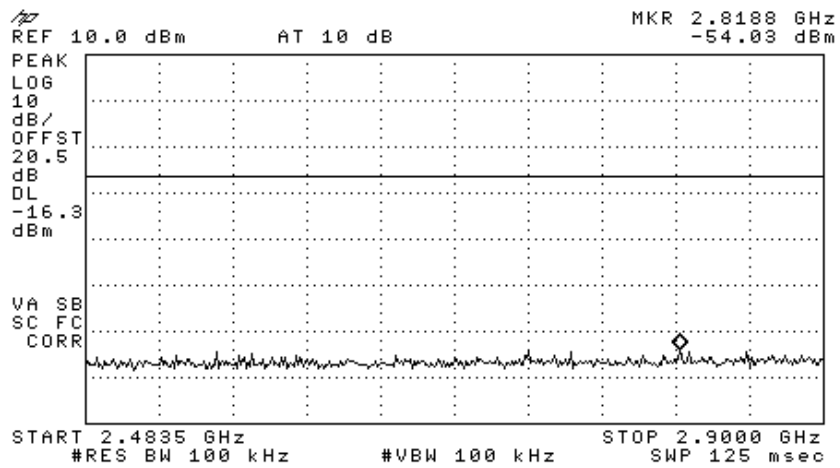

Figure 113 —2462 MHz CCK

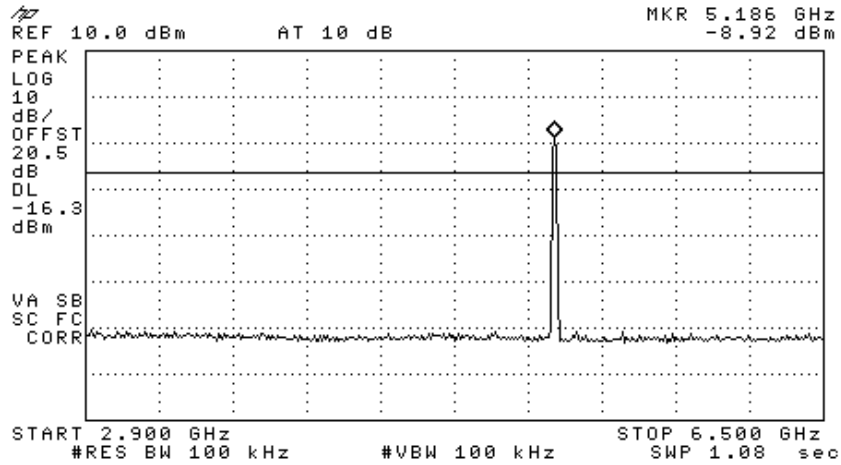

Figure 114 —2462 MHz CCK

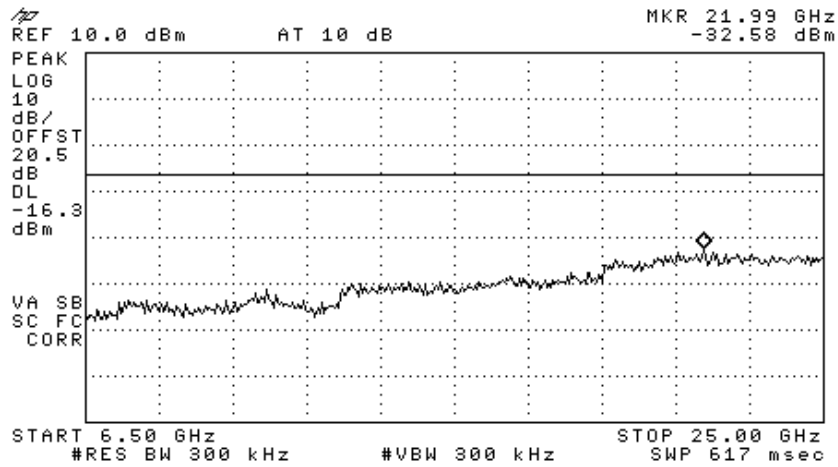

Figure 115 —2462 MHz CCK

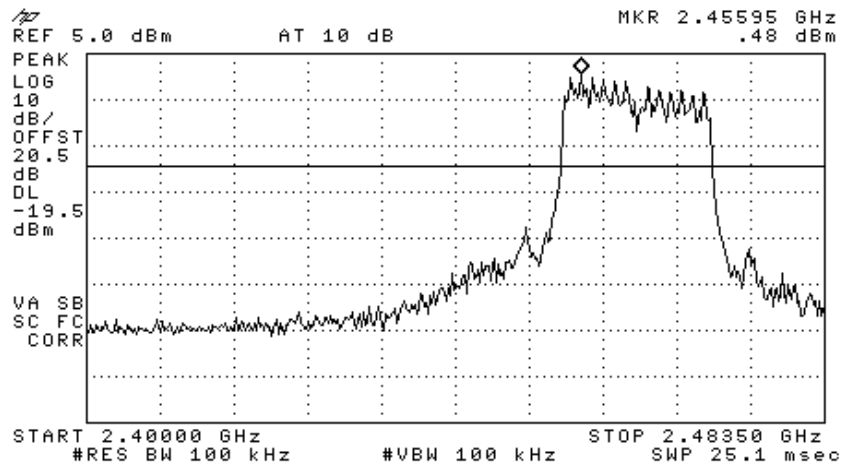

Figure 116 —2462 MHz 64QAM

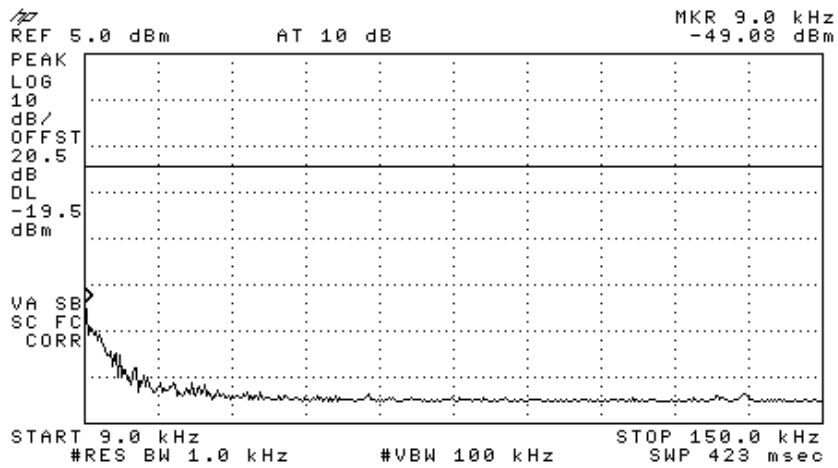

Figure 117 —2462 MHz 64QAM

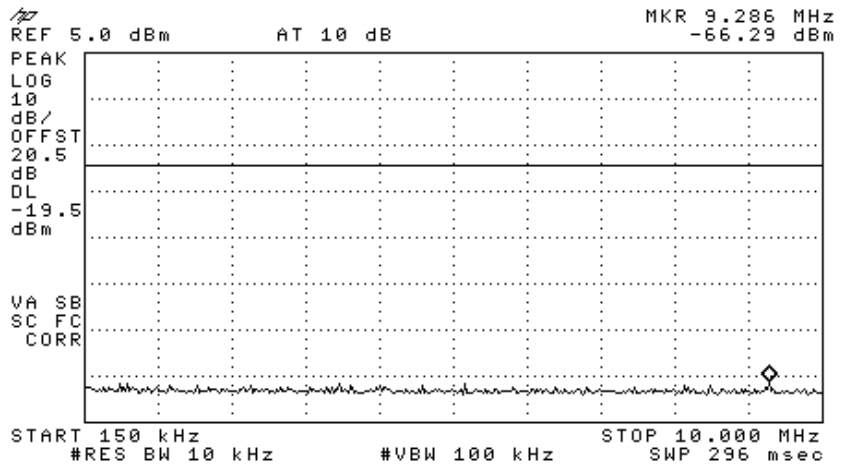

Figure 118 —2462 MHz 64QAM

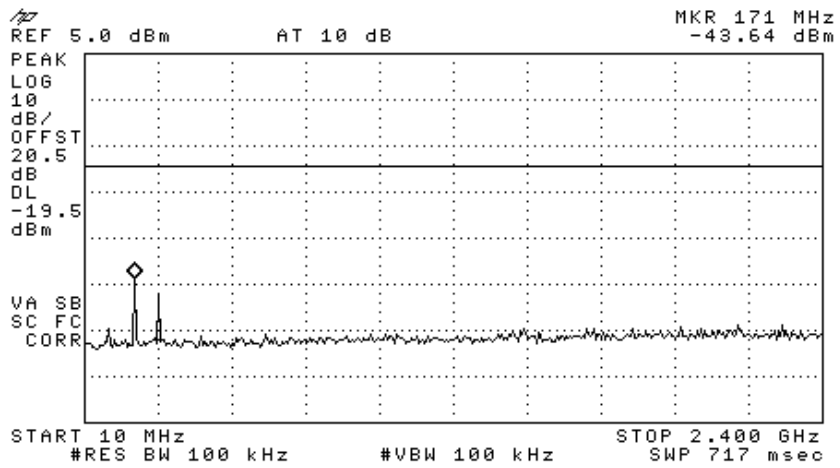

Figure 119 —2462 MHz 64QAM

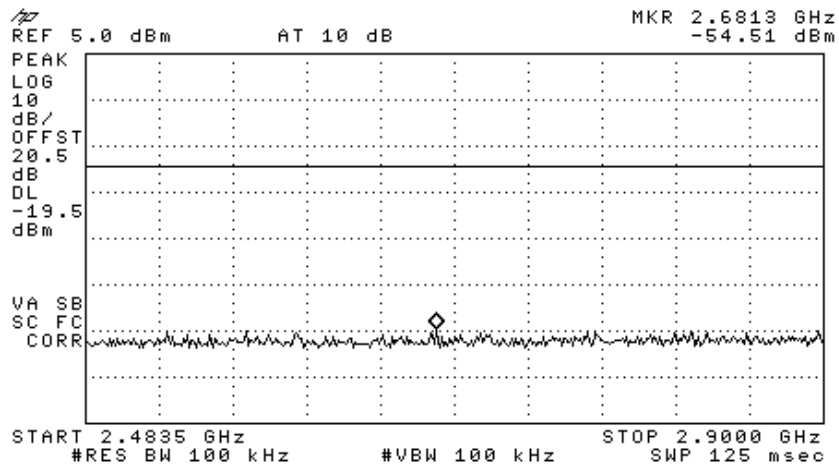

Figure 120 — 2462 MHz 64QAM

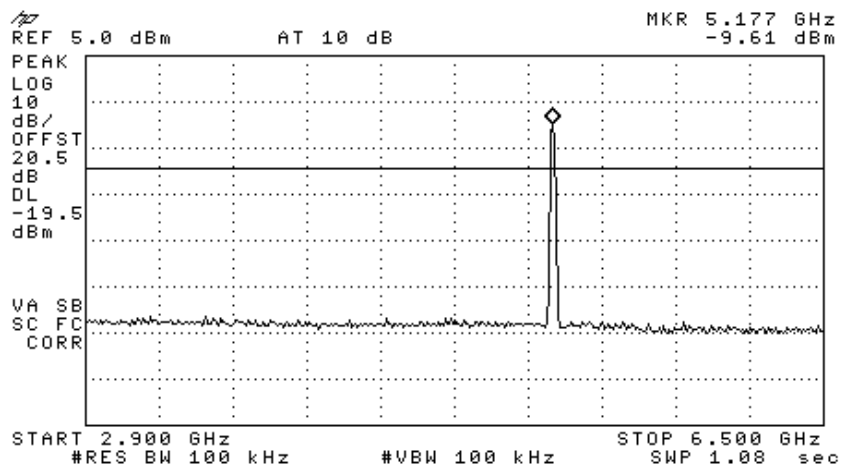

Figure 121 — 2462 MHz 64QAM

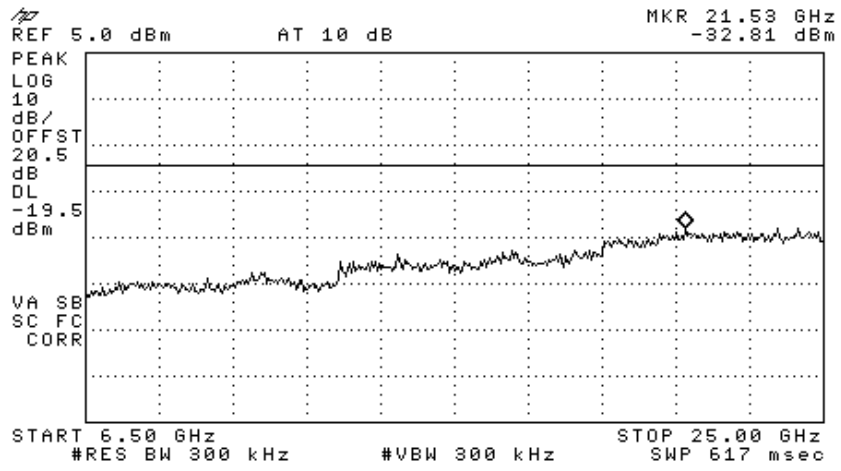

Figure 122 —2462 MHz 64QAM

8.2 Results table

E.U.T Description: WLAN Module With WCE (WiFi Coverage Extender) for DAS With Four Cisco 1242 Access Points

Model No.: 860M With WCE

Serial Number: 1. 860M: 73903D

2. WCE: 739038

Specification: F.C.C. Part 15, Subpart C (15.247)

Operation Frequency (MHz)	Modulation	Reading (dBc)	Specification (dBc)	Margin (dB)
2412	DBPSK	42.36	20.0	-22.36
	BPSK	32.29	20.0	-12.29
	CCK	33.91	20.0	-13.91
	64QAM	33.06	20.0	-13.06
2437	DBPSK	37.49	20.0	-17.49
	BPSK	38.42	20.0	-18.42
	CCK	38.98	20.0	-18.98
	64QAM	36.34	20.0	-16.34
2462	DBPSK	35.24	20.0	-15.24
	BPSK	36.81	20.0	-16.81
	CCK	36.28	20.0	-16.28
	64QAM	33.31	20.0	-13.31

Figure 123 Peak Power Output of 2400-2483.5 MHz Band

JUDGEMENT: Passed by 12.29 dB

TEST PERSONNEL:

Tester Signature: 

Date: 05.02.08

Typed/Printed Name: E. Pitt

8.3 Test Equipment Used.

Peak Power Output of 2400-2438.5 MHz Band

Instrument	Manufacturer	Model	Serial/Part Number	Calibration	
				Last Calibr.	Period
Spectrum Analyzer	HP	8592L	3826A01204	February 22, 2007	1 year
Attenuator	Jyebao	-	FAT-AM5AF5G6G2W20	May 9, 2007	1 year
Cable	Rhophase	KPS-5000-KPS	A1674	February 8, 2007	1 year

Figure 124 Test Equipment Used

9. 6 dB Minimum Bandwidth 2.4GHz Transmitter 802.11b/g + 802.11a Signals

9.1 Test procedure

The E.U.T. was set to the applicable test frequency. The E.U.T. antenna terminal was connected to the spectrum analyzer through an external attenuator (20 dB) and an appropriate coaxial cable (cable loss = 0.5 dB). The spectrum analyzer was set to 100 kHz resolution BW. The spectrum bandwidth of the E.U.T. at the point of 6 dB below maximum peak power was measured and recorded.

The E.U.T. was tested at 2412, 2437, and 2462 MHz with the following modulations: DBPSK (1Mbit/sec), BPSK (6Mbit/sec), CCK (11Mbit/sec) and 64QAM (54Mbit/sec).

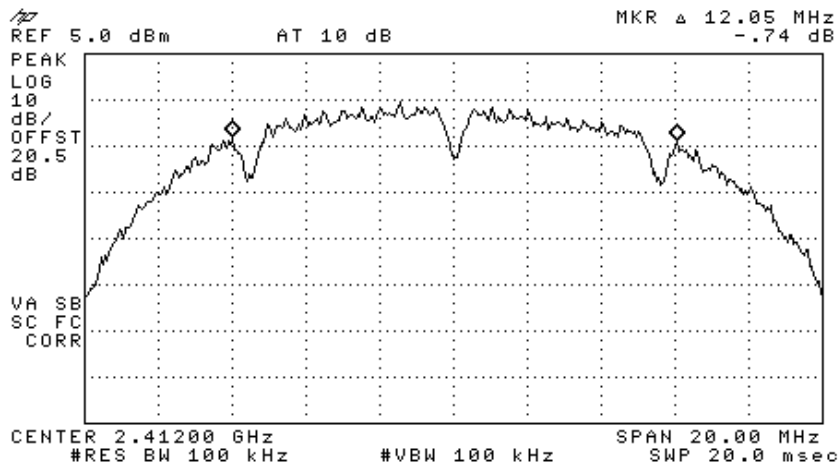

Figure 125 —2412 MHz DBPSK

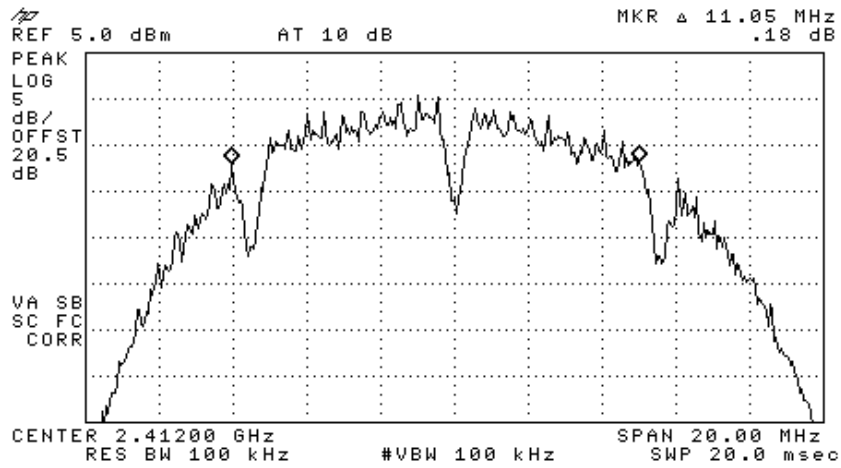

Figure 126 —2412 MHz BPSK

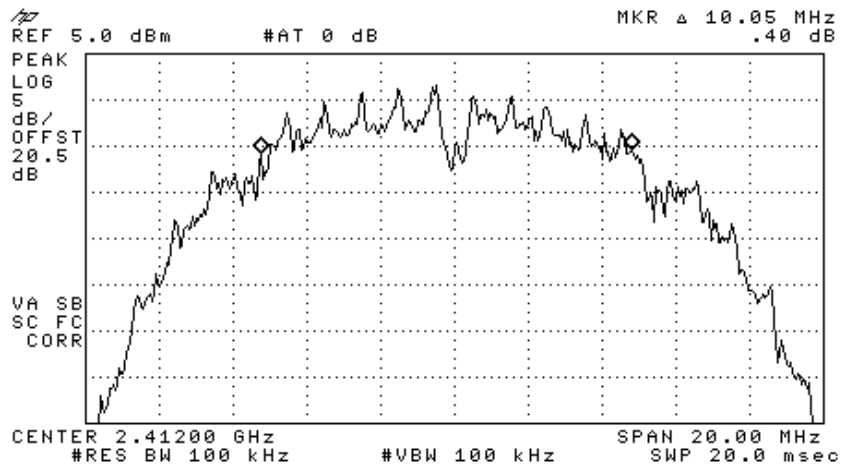

Figure 127 —2412 MHz CCK

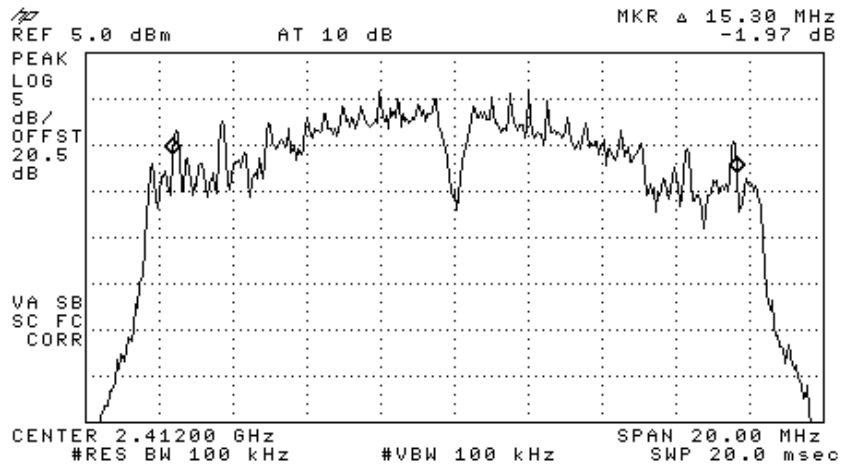

Figure 128 —2412 MHz 64QAM

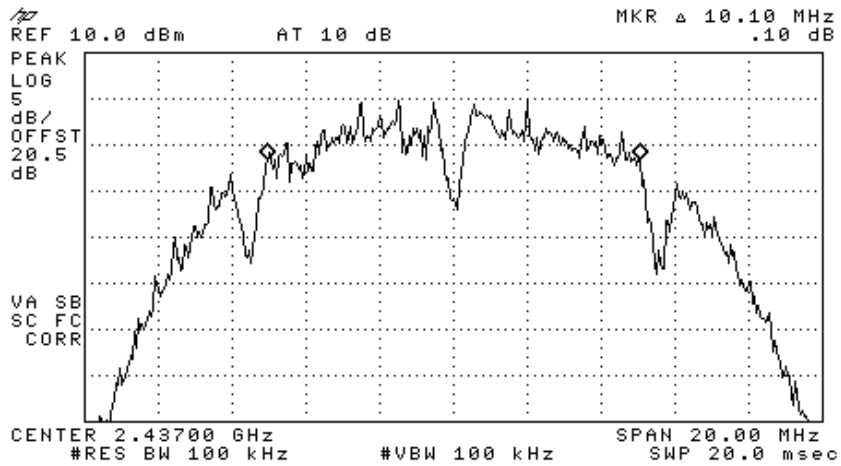

Figure 129 —2437 MHz DBPSK

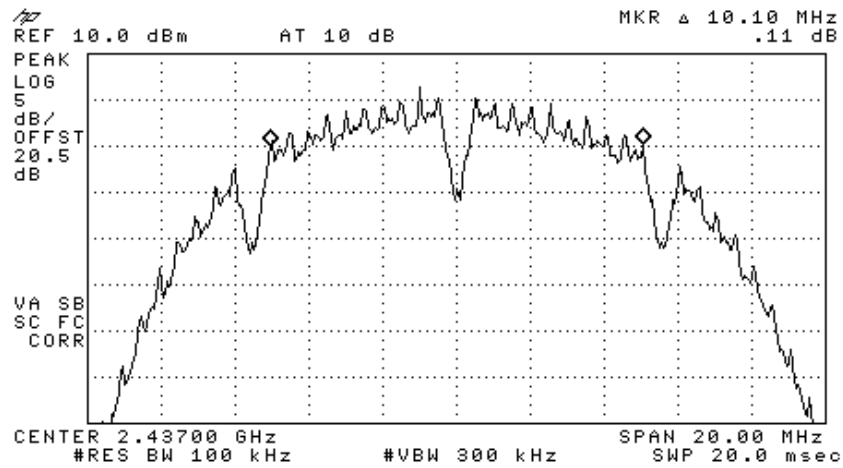

Figure 130 —2437 MHz BPSK

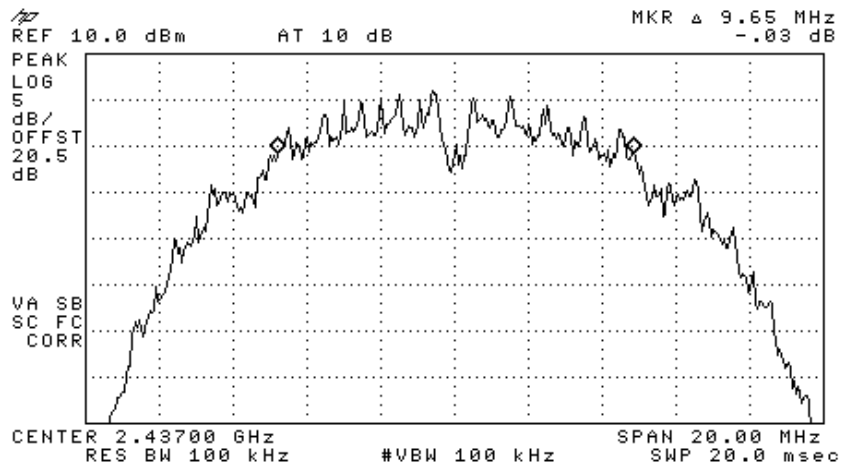

Figure 131 —2437 MHz CCK

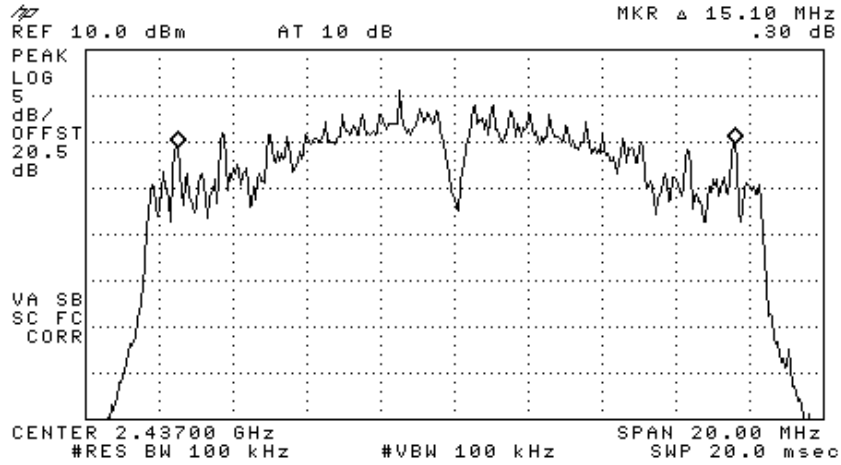

Figure 132 —2437 MHz 64QAM

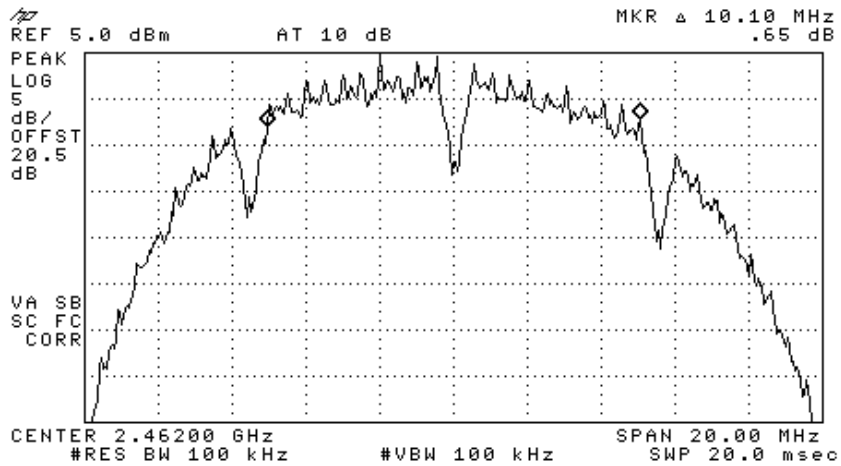

Figure 133 —2462 MHz DBPSK

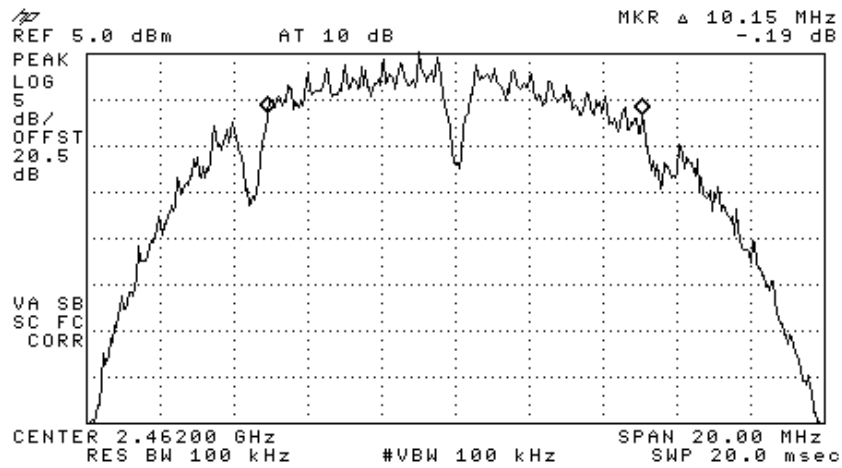

Figure 134 —2462 MHz BPSK

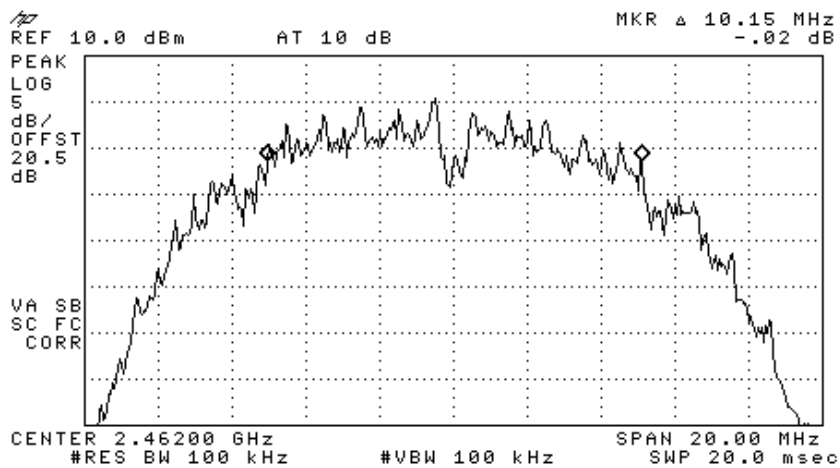

Figure 135 —2642 MHz CCK

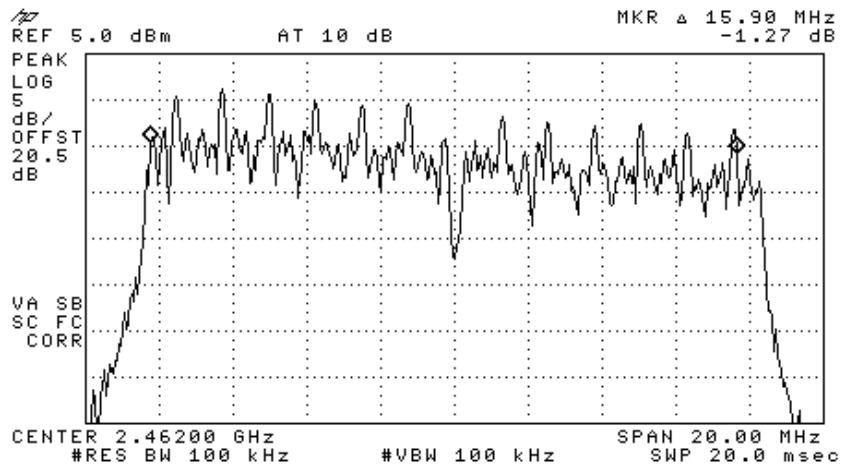

Figure 136 —2462 MHz 64QAM



9.2 Results table

E.U.T Description: WLAN Module With WCE (WiFi Coverage Extender) for DAS With Four Cisco 1242 Access Points

Model No.: 860M With WCE

Serial Number: 1. 860M: 73903D

2. WCE: 739038

Specification: F.C.C. Part 15, Subpart C: (15.247-a2)

Operation Frequency (MHz)	Modulation	Reading (MHz)	Specification (MHz)
2412	DBPSK	12.05	0.5
	BPSK	11.05	0.5
	CCK	10.05	0.5
	64QAM	15.30	0.5
2437	DBPSK	10.10	0.5
	BPSK	10.10	0.5
	CCK	9.65	0.5
	64QAM	15.10	0.5
2462	DBPSK	10.10	0.5
	BPSK	10.15	0.5
	CCK	10.15	0.5
	64QAM	15.90	0.5

Figure 137 6 dB Minimum Bandwidth

JUDGEMENT: Passed

TEST PERSONNEL:

Tester Signature: *E. Pitt*

Date: 05.02.08

Typed/Printed Name: E. Pitt

9.3 Test Equipment Used.

6 dB Minimum Bandwidth

Instrument	Manufacturer	Model	Serial/Part Number	Calibration	
				Last Calibr.	Period
Spectrum Analyzer	HP	8592L	3826A01204	February 22, 2007	1 year
Attenuator	Jyebao	-	FAT-AM5AF5G6G2W20	May 9, 2007	1 year
Cable	Rhophase	KPS-5000-KPS	A1674	February 8, 2007	1 year

Figure 138 Test Equipment Used

10. Band Edge Spectrum 2.4GHz Transmitter 802.11b/g + 802.11a Signals

[In Accordance with section 15.247(c)]

10.1 Test procedure

The E.U.T. antenna terminal was connected to the spectrum analyzer through an external attenuator (20 dB) and an appropriate coaxial cable (cable loss = 0.5 dB). The spectrum analyzer was set to 100 kHz resolution BW. Maximum power level below 2400 MHz and above 2483.5 MHz was measured relative to power level at 2412 MHz, and 2462 MHz correspondingly.

The E.U.T. was tested using the following modulations: DBPSK (1Mbit/sec), BPSK (6Mbit/sec), CCK (11Mbit/sec) and 64QAM (54Mbit/sec).

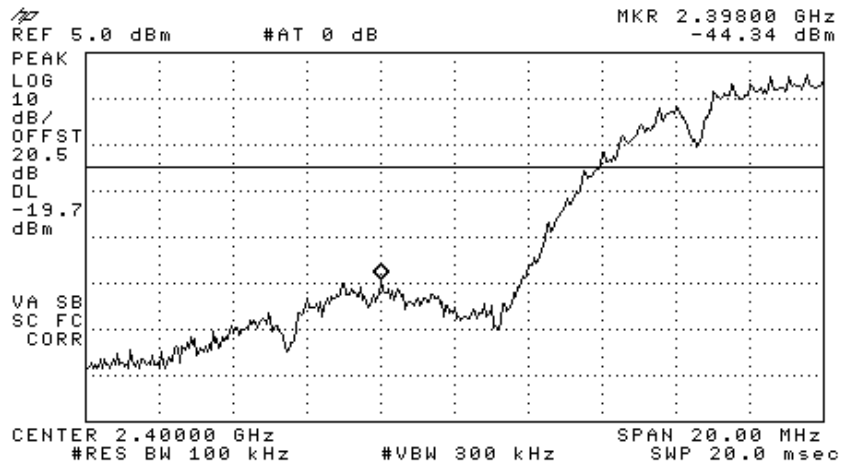

Figure 139 —2412 MHz DBPSK

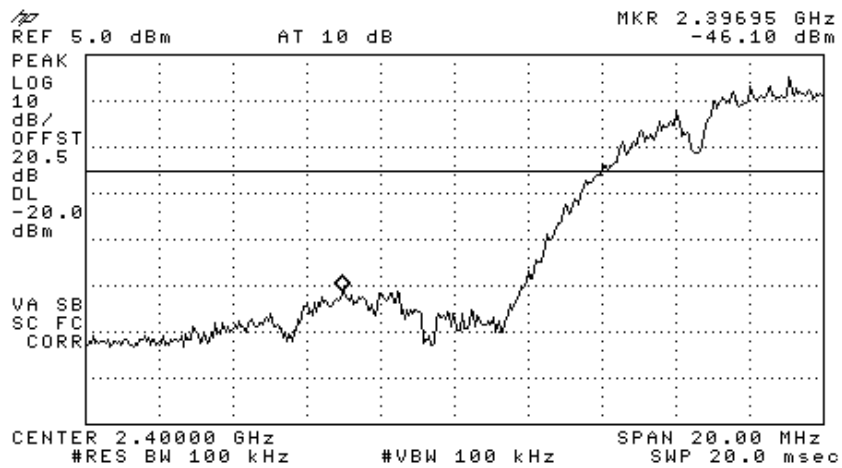

Figure 140 —2412 MHz BPSK

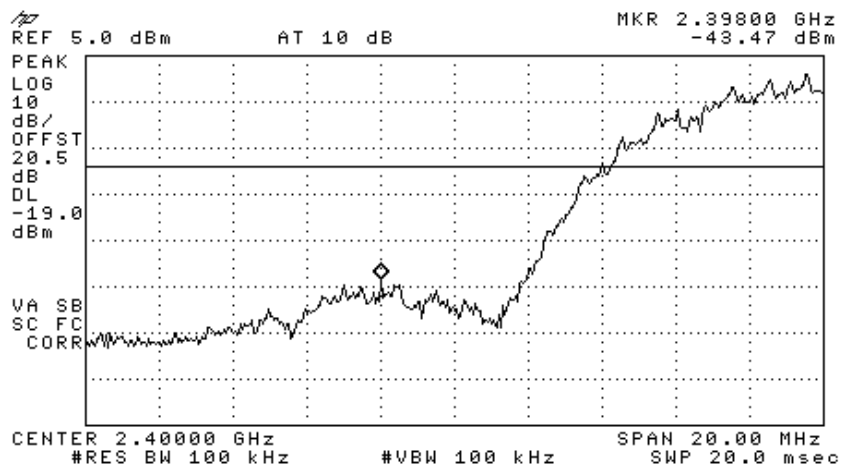

Figure 141 —2412 MHz CCK

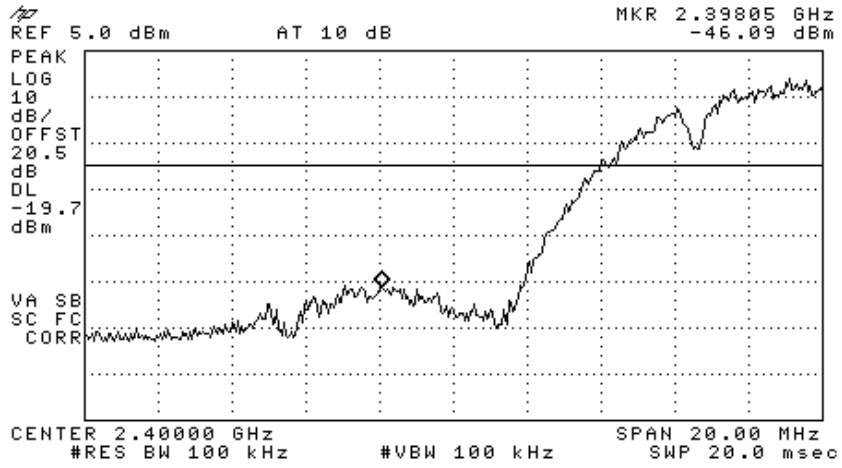

Figure 142 —2412 MHz 64QAM

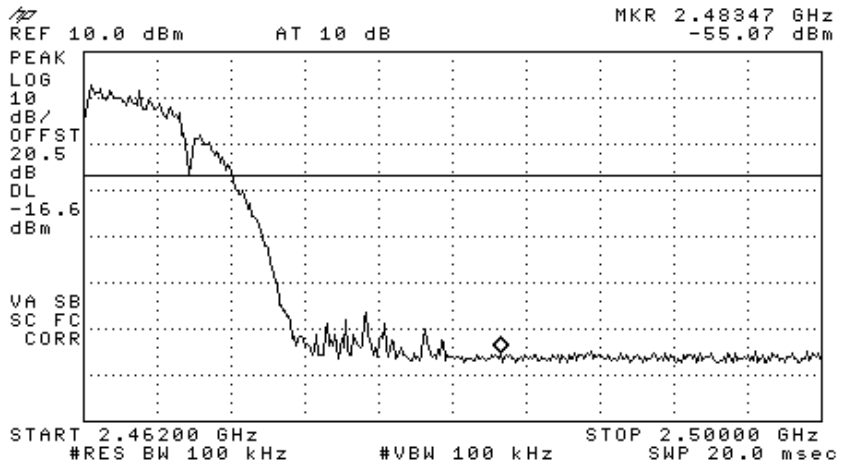

Figure 143 —2462 MHz DBPSK

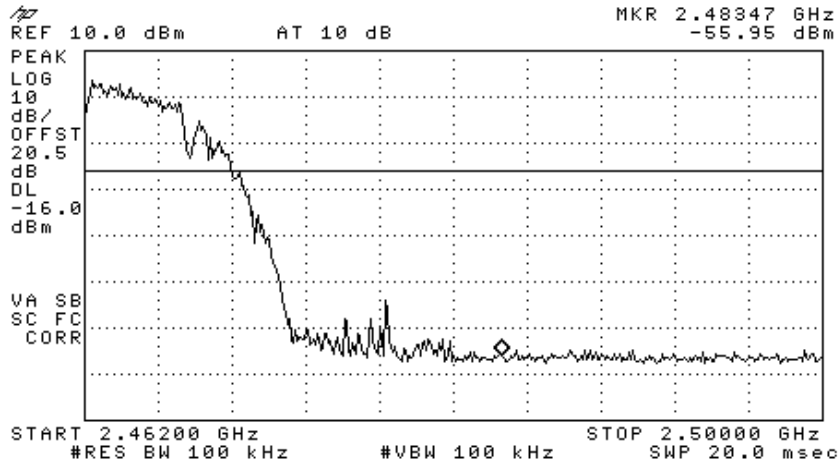

Figure 144 —2462 MHz BPSK

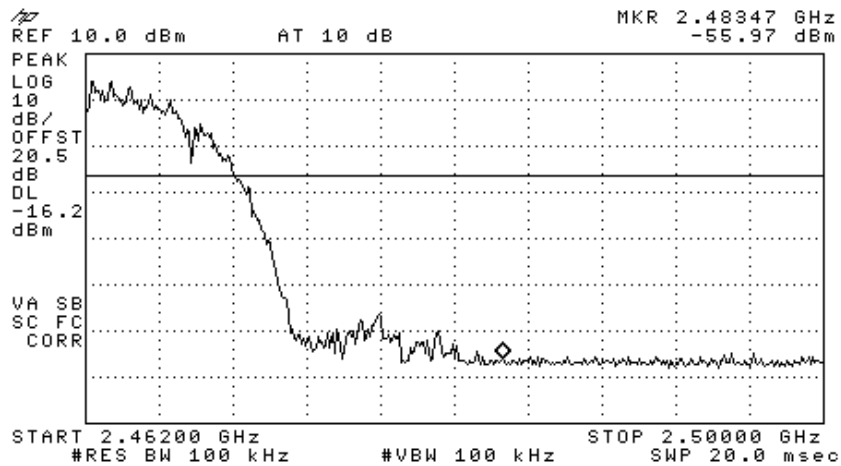

Figure 145 —2462 MHz CCK

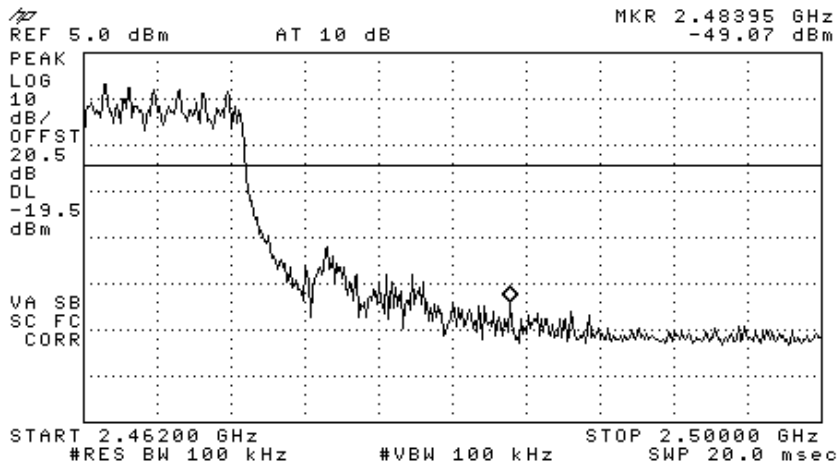

Figure 146 —2462 MHz 64QAM

10.2 Results table

E.U.T. Description: WLAN Module With WCE (WiFi Coverage Extender) for DAS
 With Four Cisco 1242 Access Points
 Model No.: 860M With WCE
 Serial Number: 1. 860M: 73903D
 2. WCE: 739038
 Specification: F.C.C. Part 15, Subpart C (15.247)

Operation Frequency (MHz)	Modulation	Band Edge Frequency (MHz)	Spectrum Level (dBc)	Specification (dBc)	Margin (dB)
2412	DBPSK	2.39800	44.34	20.0	-24.34
	BPSK	2.39695	46.10	20.0	-26.10
	CCK	2.39800	43.47	20.0	-23.47
	64QAM	2.39805	46.09	20.0	-26.09
2642	DBPSK	2.48347	55.07	20.0	-32.07
	BPSK	2.48347	55.95	20.0	-35.95
	CCK	2.48347	55.97	20.0	-35.97
	64QAM	2.48395	49.07	20.0	-29.07

Figure 147 Band Edge Spectrum

JUDGEMENT: Passed by 2.37 dB

TEST PERSONNEL:

Tester Signature: 

Date: 05.02.08

Typed/Printed Name: E. Pitt

10.3 Test Equipment Used.

Band edge Spectrum

Instrument	Manufacturer	Model	Serial/Part Number	Calibration	
				Last Calibr.	Period
Spectrum Analyzer	HP	8592L	3826A01204	February 22, 2007	1 year
Attenuator	Jyebao	-	FAT-AM5AF5G6G2W20	May 9, 2007	1 year
Cable	Rhophase	KPS-5000-KPS	A1674	February 8, 2007	1 year

Figure 148 Test Equipment Used

11. Transmitted Power Density 2.4GHz Transmitter 802.11 b/g +a Signals

[In accordance with section 15.247(d)]

11.1 Test procedure

The E.U.T. antenna terminal was connected to the spectrum analyzer through an external attenuator (20dB) and an appropriate coaxial cable (cable loss = 0.5dB). The spectrum analyzer was set to 3 kHz resolution BW. and sweep time of 1 second for each 3 kHz “window”. The spectrum peaks were located at each of the 3 operating frequencies.

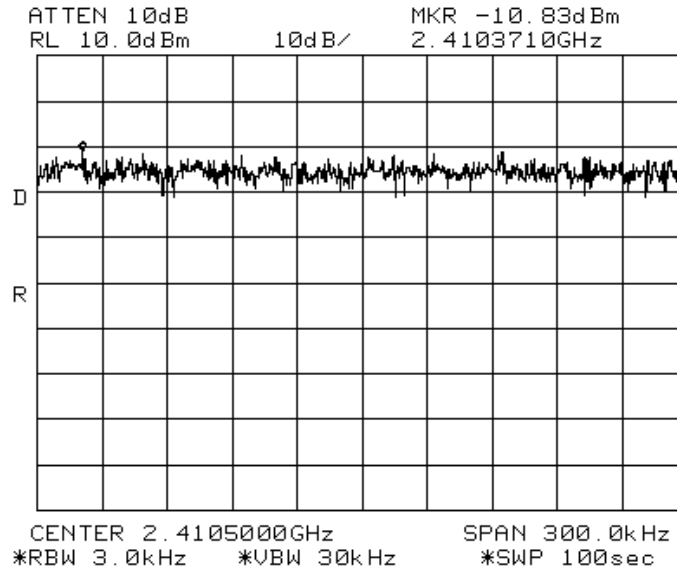

Figure 149 —2412 MHz DBPSK

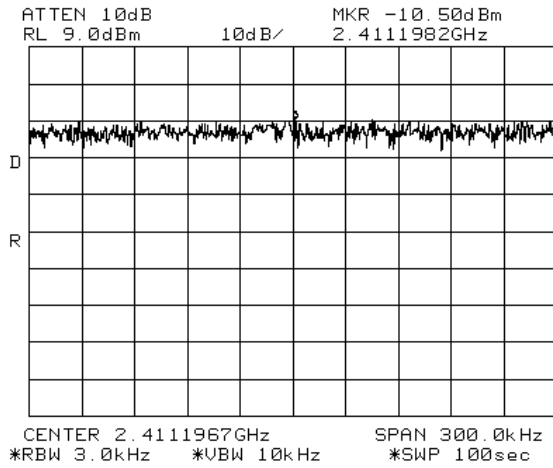

Figure 150 —2412 MHz BPSK

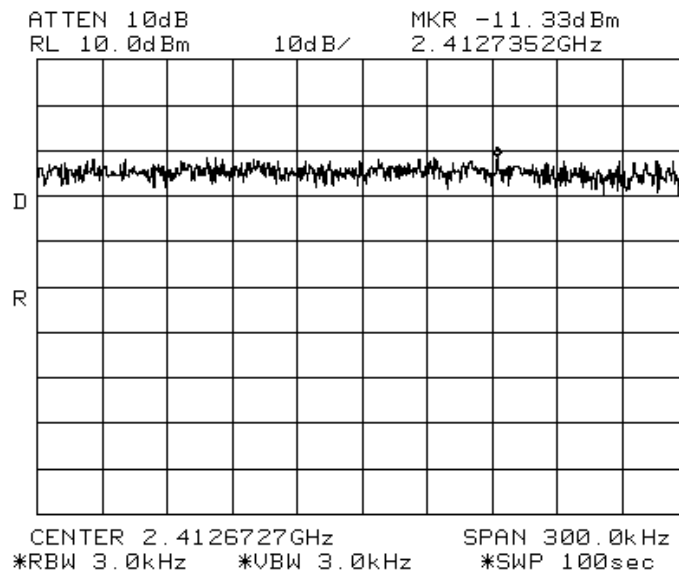

Figure 151 —2412 MHz CCK

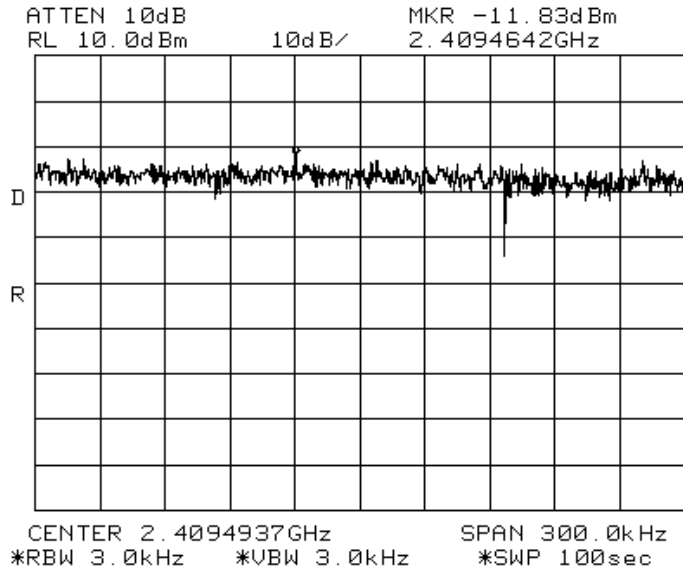

Figure 152 —2412 MHz 64QAM

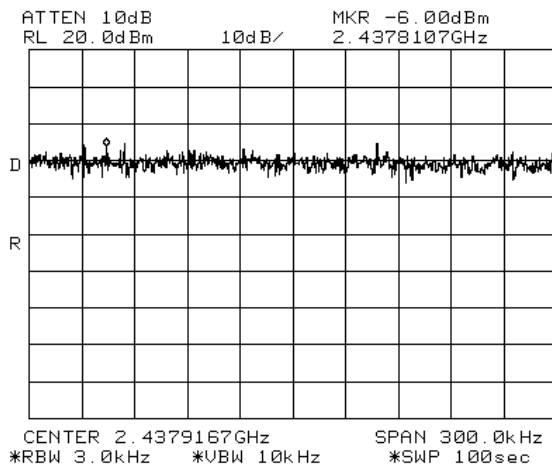

Figure 153 —2437 MHz DBPSK

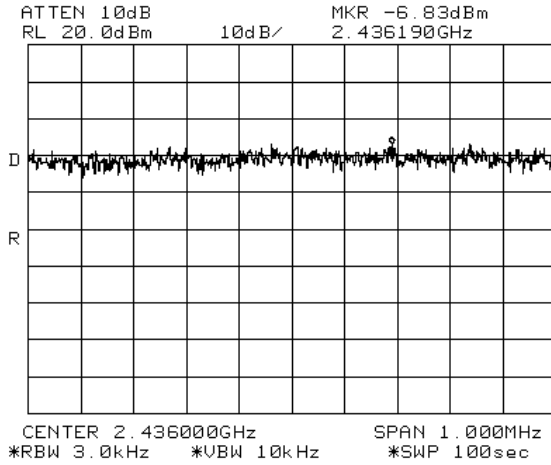

Figure 154 — 2437 MHz BPSK

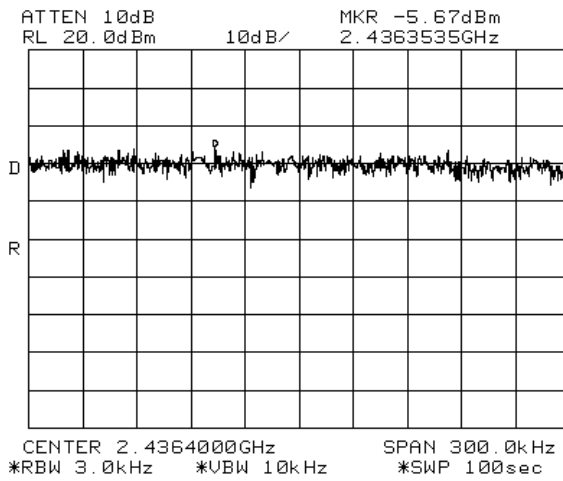

Figure 155 — 2437 MHz CCK

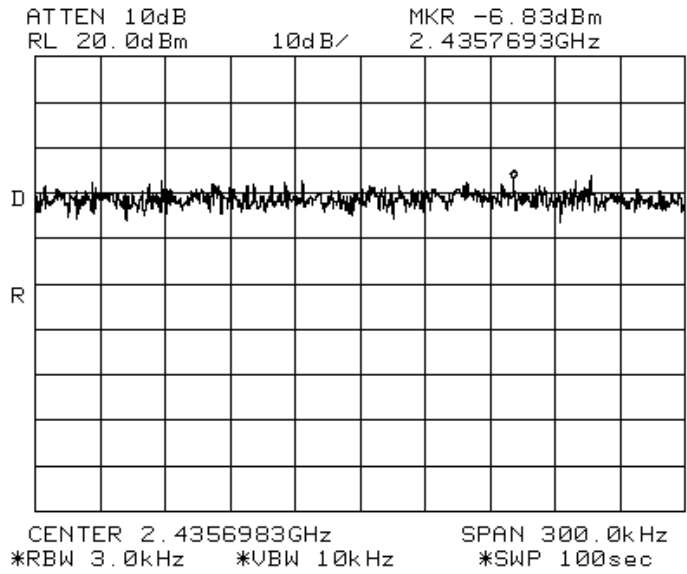

Figure 156 —2437 MHz 64QAM

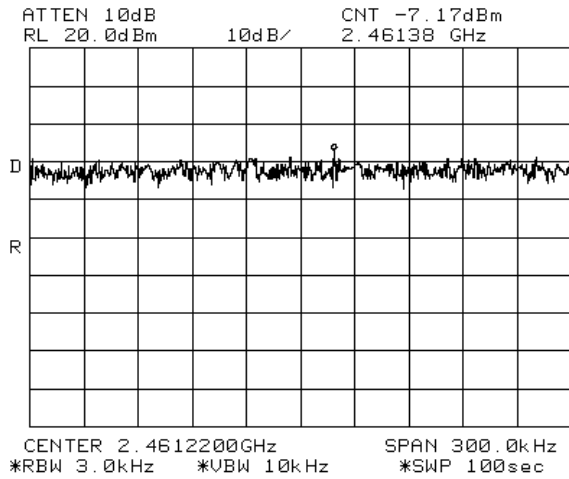

Figure 157 —2462 MHz DBPSK

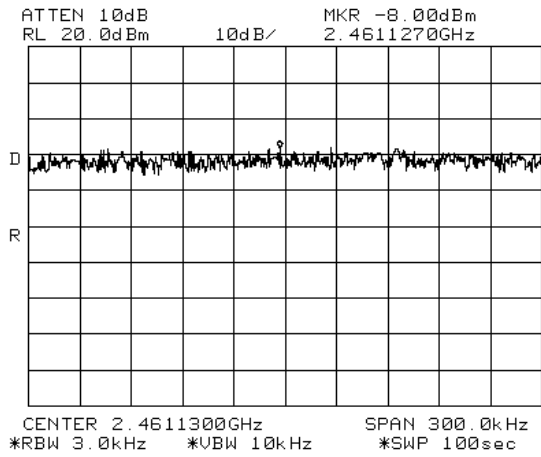

Figure 158 —2462 MHz BPSK

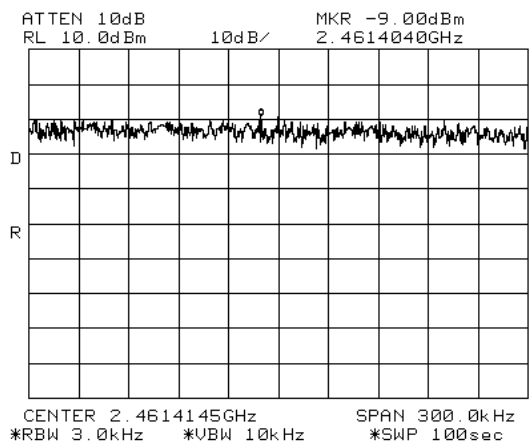

Figure 159 —2462 MHz CCK

11.2 Results table

E.U.T. Description: WLAN Module With WCE (WiFi Coverage Extender) for DAS With Four Cisco 1242 Access Points
 Model No.: 860M With WCE
 Serial Number: 1. 860M: 73903D
 2. WCE: 739038
 Specification: F.C.C. Part 15, Subpart C (15.247)

Operation Frequency (MHz)	Modulation	Reading Spectrum Analyzer (dBm)	Specification (dBm)	Margin (dB)
2412	DBPSK	-10.83	8.0	-18.83
2412	BPSK	-10.50	8.0	-18.50
2412	CCK	-11.33	8.0	-19.33
2412	64QAM	-11.83	8.0	-19.83
2437	DBPSK	-6.00	8.0	-14.00
2437	BPSK	-6.83	8.0	-14.83
2437	CCK	-5.67	8.0	-13.67
2437	64QAM	-6.83	8.0	-14.83
2462	DBPSK	-7.17	8.0	-15.17
2462	BPSK	-8.00	8.0	-16.00
2462	CCK	-9.00	8.0	-17.00
2462	64QAM	-11.17	8.0	-19.17

Figure 161 Test Results

JUDGEMENT: Passed by 13.67 dB

TEST PERSONNEL:

Tester Signature: 

Date: 05.02.08

Typed/Printed Name: E. Pitt

11.3 Test Equipment Used.

Transmitted Power Density

Instrument	Manufacturer	Model	Serial/Part Number	Calibration	
				Last Calibr.	Period
Spectrum Analyzer	HP	8564E	3442A00275	November 14, 2007	1 year
Attenuator	Jyebao	-	FAT-AM5AF5G6G2W20	May 9, 2007	1 year
Cable	Rhophase	KPS-5000-KPS	A1674	February 8, 2007	1 year

Figure 162 Test Equipment Used

12. Antenna Gain 2.4GHz Transmitter 802.11 b/g +a Signals

The antenna gain is 7 dBi.

13. R.F Exposure/Safety 2.4GHz Transmitter 802.11 b/g +a Signals

Typical use of the E.U.T. is repeating WiFi signals for DAS. The typical placement of the E.U.T. is on a wall near the ceiling. The typical distance between the E.U.T. and the user in the worst case application, is >1 m.

Calculation of Maximum Permissible Exposure (MPE)
Based on Section 1.1307(b)(1) Requirements

(a) FCC limits at 2437 MHz is: $1 \frac{mW}{cm^2}$

Using table 1 of Section 1.1310 limit for general population/uncontrolled exposures, the above level is an average over 30 minutes.

(b) The power density produced by the E.U.T. is

$$S = \frac{P_t G_t}{4\pi R^2}$$

P_t - Transmitted Power 151.3 mw (Peak) = 21.5 dBm

G_T - Antenna Gain, 7 dBi = 5

R- Distance from Transmitter using 1 m worst case

(c) The peak power density is :

$$S_p = \frac{5 \times 151.3}{4\pi(100)^2} = 6.02 \times 10^{-3} \frac{mW}{cm^2}$$

(d) The duty cycle of transmission in actual worst case is 50%.

The average power source is:

$$75.6mW$$

(e) The averaged power density of the E.U.T. is:

$$S_{AV} = \frac{75.6 \times 5}{4\pi(100)^2} = 3.01 \times 10^{-3} \frac{mW}{cm^2}$$

(f) This is 3 orders of magnitude below the FCC limit.

14. Radiated Emission Per FCC Part 15 Sub-Part B Test Data 802.11 b/g +802.11a Signals

14.1 Test Specification

30-25000 MHz, FCC Part 15, Subpart B, CLASS B

14.2 Test Procedure

The E.U.T. operation mode and test set-up are as described in Section 4.

A preliminary measurement to characterize the E.U.T was performed inside the shielded room at a distance of 3 meters, using peak detection mode and broadband antennas. The preliminary measurements produced a list of the highest emissions. The E.U.T was then transferred to the open site, and placed on a remote-controlled turntable. The E.U.T was placed on a non-metallic table, 0.8 meters above the ground. The effect of varying the position of the cables was investigated to find the configuration that produces maximum emission.

The frequency range 30-25000 MHz was scanned, and the list of the highest emissions was verified and updated accordingly.

The emissions were measured using a computerized EMI receiver complying to CISPR 16 requirements. The specification limits and applicable correction factors are loaded to the receiver via a 3.5" floppy disk.

In the frequency range 2.9 - 25 GHz, a spectrum analyzer including a low noise amplifier was used. The test distance was 3 meters. During peak measurements, the I.F. bandwidth was 1 MHz, and video bandwidth 3 MHz. During average measurements, the I.F. bandwidth was 1 MHz and video bandwidth was 100 Hz.

The readings were maximized by adjusting the antenna height between 1-4 meters, the turntable azimuth between 0-360°, and the antenna polarization. Verification of the E.U.T emissions was based on the following methods: turning the E.U.T on and off; using a frequency span less than 10 MHz; observation of the signal level during turntable rotation. (Background noise is not affected by the rotation of the E.U.T.)

The emissions were measured at a distance of 3 meters.

The E.U.T. was tested in both Rx and Tx modes.

The E.U.T. was tested at the operating frequencies of 2412, 2437, and 2462 MHz using the following modulations: DBPSK, BPSK, CCK, and 64QAM.

Radiated Emission

E.U.T Description WLAN Module With WCE (WiFi Coverage Extender) for DAS With Four Cisco 1242 Access Points

Type 860M With WCE

Serial Number: 1. 860M: 73903D
 2. WCE: 739038

Specification: FCC Part 15, Subpart B, Class B

Antenna Polarization: Horizontal Frequency range: 30 MHz to 300 MHz
 Antenna: 3 meters distance Detectors: Peak, Quasi-peak

Frequency	Peak Amp	QP Amp	Correction	Specification	Margin
(MHz)	(dB μ V/m)	(dB μ V/m)	(dB)	(dB μ V/m)	(dB)
39.70	31.7	27.3	13.4	40.0	-12.7
46.92	28.4	23.5	12.1	40.0	-16.5
162.58	36.0	31.7	15.4	43.5	-11.8
175.07	40.8	35.8	15.9	43.5	-7.7
207.20	37.1	32.2	18.0	43.5	-11.3
242.11	40.6	36.0	20.0	46.0	-10.0

**Figure 163. Radiated Emission. Antenna Polarization: HORIZONTAL.
 Detectors: Peak, Quasi-peak**

Note: Margin refers to the test results obtained minus specified requirement; thus a positive number indicates failure, and a negative result indicates that the product passes the test.

Radiated Emission

E.U.T Description WLAN Module With WCE (WiFi Coverage Extender) for DAS With Four Cisco 1242 Access Points
 Type 860M With WCE
 Serial Number: 1. 860M: 73903D
 2. WCE: 739038

Specification: FCC Part 15, Subpart B, Class B

Antenna Polarization: Horizontal
 Antenna: 3 meters distance

Frequency range: 30 MHz to 300 MHz
 Detectors: Peak, Quasi-peak

 13:48:32 FEB 04, 2008

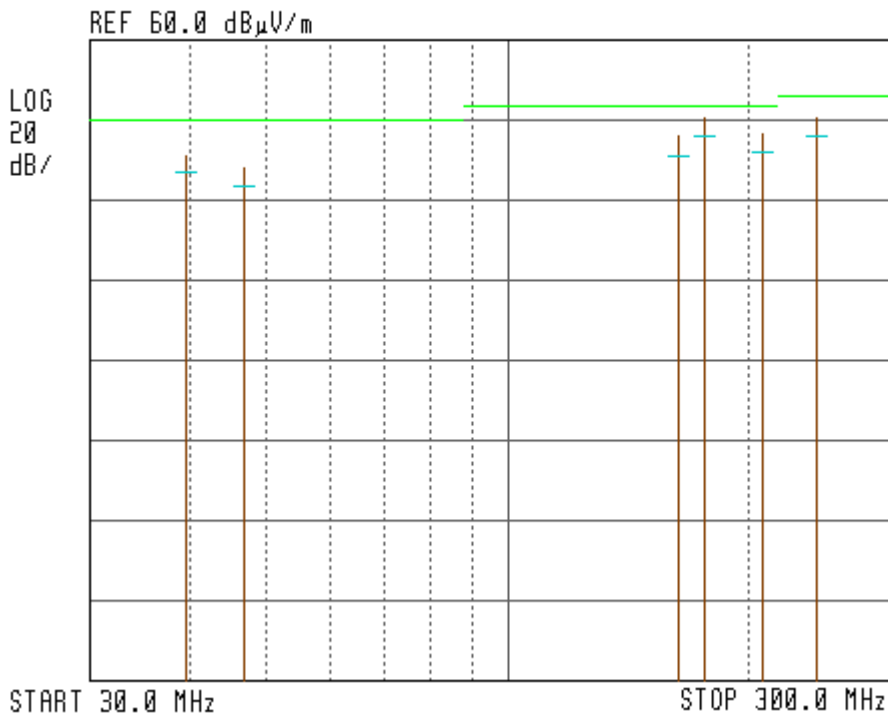

**Figure 164. Radiated Emission. Antenna Polarization: HORIZONTAL
 Detectors: Peak, Quasi-peak**

Note:

1. Horizontal axis shows logarithmic frequency scale.
2. The vertical axis shows amplitude (in dB μ V/m).
3. Peak detection is designated by the top of each vertical line.
4. Quasi-peak detection is designated by the first dash mark (from the top) of each vertical line.

Radiated Emission

E.U.T Description WLAN Module With WCE (WiFi Coverage Extender) for DAS With Four Cisco 1242 Access Points

Type 860M With WCE

Serial Number: 1. 860M: 73903D
 2. WCE: 739038

Specification: FCC Part 15, Subpart B, Class B

Antenna Polarization: Vertical
 Antenna: 3 meters distance

Frequency range: 30 MHz to 300 MHz
 Detectors: Peak, Quasi-peak

Frequency (MHz)	Peak Amp (dB μ V/m)	QP Amp (dB μ V/m)	Correction (dB)	Specification (dB μ V/m)	Margin (dB)
34.93	36.0	32.1	14.7	40.0	-7.9
39.70	41.6	36.5	13.4	40.0	-3.5
46.15	44.4	34.8	12.2	40.0	-5.2
162.58	41.6	38.8	15.4	43.5	-4.7
175.07	40.9	37.6	15.9	43.5	-5.9
242.11	38.6	34.7	20.0	46.0	-11.3

**Figure 165. Radiated Emission. Antenna Polarization: VERTICAL.
 Detectors: Peak, Quasi-peak**

Note: Margin refers to the test results obtained minus specified requirement; thus a positive number indicates failure, and a negative result indicates that the product passes the test.

Radiated Emission

E.U.T Description WLAN Module With WCE (WiFi Coverage Extender) for DAS With Four Cisco 1242 Access Points
 Type 860M With WCE
 Serial Number: 1. 860M: 73903D
 2. WCE: 739038

Specification: FCC Part 15, Subpart B, Class B

Antenna Polarization: Vertical
 Antenna: 3 meters distance

Frequency range: 30 MHz to 300 MHz
 Detectors: Peak, Quasi-peak

 12:34:02 FEB 04, 2008

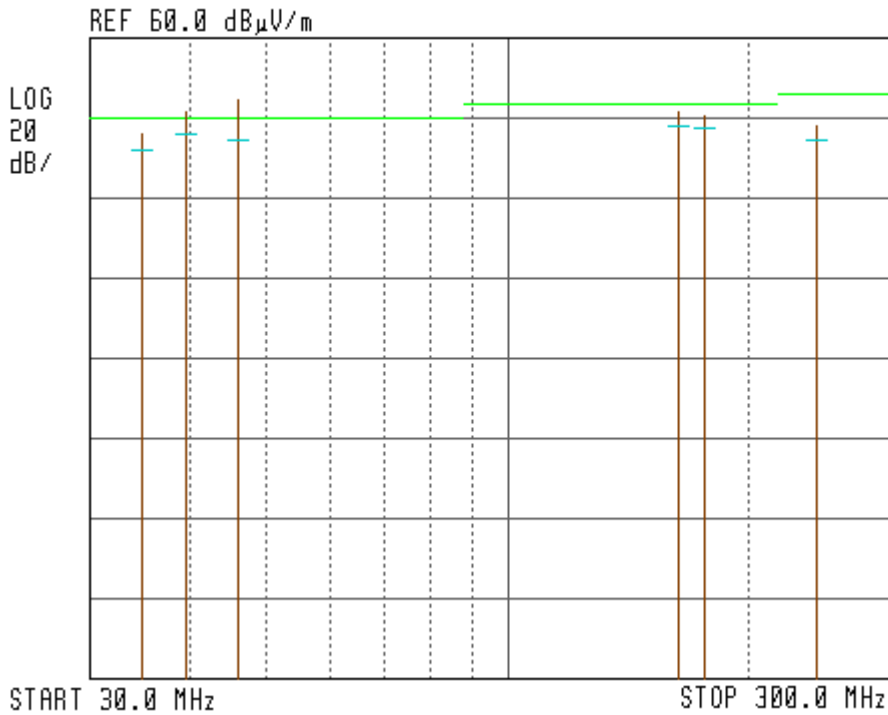

Figure 166. Radiated Emission. Antenna Polarization: VERTICAL. Detectors: Peak, Quasi-peak

Note:

1. Horizontal axis shows logarithmic frequency scale.
2. The vertical axis shows amplitude (in dB μ V/m).
3. Peak detection is designated by the top of each vertical line.
4. Quasi-peak detection is designated by the first dash mark (from the top) of each vertical line.

14.4 Test Instrumentation Used, Radiated Measurements

Instrument	Manufacturer	Model	Serial No.	Calibration	Period
EMI Receiver	HP	85422E	3906A00276	November 12, 2007	1 Year
RF Filter Section	HP	85420E	3705A00248	November 12, 2007	1 Year
Antenna Biconical	ARA	BCD 235/B	1041	March 22, 2007	1 Year
Antenna Log Periodic	ARA	LPD-2010/A	1038	November 22, 2007	1 Year
Antenna Log Periodic	A.H. Systems	SAS-200/511	253	February 4, 2007	2 Years
Double Ridged Waveguide Horn Antenna	EMCO	3115	29845	March 15, 2006	2 Years
Horn Antenna	ARA	SWH-28	1008	December 8, 2006	2 Years
Low Noise Amplifier	DBS MICROWAVE	LNA-DBS-0411N313	013	November 2, 2007	1 Year
Low Noise Amplifier	Sophia Wireless	LNA 28-B	232	January 9, 2007	1 Year
Low Noise Amplifier	MK Milliwave	MKT6-3000 4000-30-13P	399	January 9, 2007	1 Year
Spectrum Analyzer	HP	8592L	3826A01204	February 22, 2007	1 Year
Spectrum Analyzer	HP	8564E	3442A00275	November 14, 2007	1 Year
Antenna Mast	ARA	AAM-4A	1001	N/A	N/A
Turntable	ARA	ART-1001/4	1001	N/A	N/A
Mast & Table Controller	ARA	ACU-2/5	1001	N/A	N/A
Printer	HP	LaserJet 2200	JPKG19982	N/A	N/A

14.5 *Field Strength Calculation*

The field strength is calculated directly by the EMI Receiver software, and a "Correction Factors" data disk, using the following equation:

$$FS = RA + AF + CF$$

FS:	Field Strength [dB μ v/m]
RA:	Receiver Amplitude [dB μ v]
AF:	Receiving Antenna Correction Factor [dB/m]
CF:	Cable Attenuation Factor [dB]

No external pre-amplifiers are used.

15. Spurious Radiated Emission in the Restricted Band, Below 1 GHz 2.4GHz Transmitter 802.11b/g + 802.11a + CELL + PCS Signals

15.1 Test Specification

9kHz-1000 MHz, F.C.C., Part 15, Subpart C

15.2 Test Procedure

The E.U.T. operation mode and test set-up are as described in Section 3.

See Section 3.1 Justification of the System Test Configuration concerning the E.U.T. orientation for this test.

A preliminary measurement to characterize the E.U.T was performed inside the shielded room at a distance of 3 meters, using peak detection mode and broadband antennas. The preliminary measurements produced a list of the highest emissions. The E.U.T was then transferred to the open site, and placed on a remote-controlled turntable. The E.U.T was placed on a non-metallic table, 0.8 meters above the ground. The configuration tested is shown in Figure 3.1.

The frequency range 9 kHz-1000 MHz was scanned, and the list of the highest emissions was verified and updated accordingly.

The levels of the emissions within the frequency ranges of the restricted bands (Section 15.205 of FCC Part 15) were compared to the limits of the table in Section 15.209 (a), General Requirements.

The emissions were measured using a computerized EMI receiver complying to CISPR 16 requirements. The specification limits and applicable correction factors are loaded to the receiver via a 3.5" floppy disk.

In the frequency range 9 kHz-30 MHz, the loop antenna was rotated on its vertical axis, The antenna height (center of loop) was 1 meter.

In the frequency range 30-1000 MHz, the readings were maximized by adjusting the antenna height between 1-4 meters, the turntable azimuth between 0-360°, and the antenna polarization.

Verification of the E.U.T emissions was based on the following methods:

- Turning the E.U.T on and off.

- Using a frequency span less than 10 MHz.

- Observation of the signal level during turntable rotation. Background noise is not affected by the rotation of the E.U.T.

The E.U.T. was tested at the operating frequencies of 2412, 2437, and 2462 MHz using the following modulations: DBPSK, BPSK, CCK, and 64QAM.



15.3 Test Data

JUDGEMENT: Passed by 3.5 dB.

The margin between the emission level and the specification limit is 3.5 dB in the worst case at the frequency of 39.70 MHz, vertical polarization.

The EUT met the requirements of the F.C.C. Part 15, Subpart C, specification.

The results for all three operating frequencies and modulations were the same.

TEST PERSONNEL:

Tester Signature: _____ Date: 05.02.08

Typed/Printed Name: A. Sharabi

Radiated Emission

E.U.T Description WLAN Module With WCE (WiFi Coverage Extender) for DAS With Four Cisco 1242 Access Points

Type 860M With WCE

Serial Number: 1. 860M: 73903D
 2. WCE: 739038

Specification: FCC Part 15, Subpart C

Antenna Polarization: Horizontal Frequency range: 30 MHz to 300 MHz
Antenna: 3 meters distance Detectors: Peak, Quasi-peak

Frequency	Peak Amp	QP Amp	Correction	Specification	Margin
(MHz)	(dB μ V/m)	(dB μ V/m)	(dB)	(dB μ V/m)	(dB)
39.70	31.7	27.3	13.4	40.0	-12.7
46.92	28.4	23.5	12.1	40.0	-16.5
162.58	36.0	31.7	15.4	43.5	-11.8
175.07	40.8	35.8	15.9	43.5	-7.7
207.20	37.1	32.2	18.0	43.5	-11.3
242.11	40.6	36.0	20.0	46.0	-10.0

**Figure 167. Radiated Emission. Antenna Polarization: HORIZONTAL.
Detectors: Peak, Quasi-peak**

Note: Margin refers to the test results obtained minus specified requirement; thus a positive number indicates failure, and a negative result indicates that the product passes the test.

Radiated Emission

E.U.T Description WLAN Module With WCE (WiFi Coverage
 Extender) for DAS With Four Cisco 1242
 Access Points

Type 860M With WCE

Serial Number: 1. 860M: 73903D
 2. WCE: 739038

Specification: FCC Part 15, Subpart C

Antenna Polarization: Horizontal
Antenna: 3 meters distance

Frequency range: 30 MHz to 300 MHz
Detectors: Peak, Quasi-peak

13:48:32 FEB 04, 2008

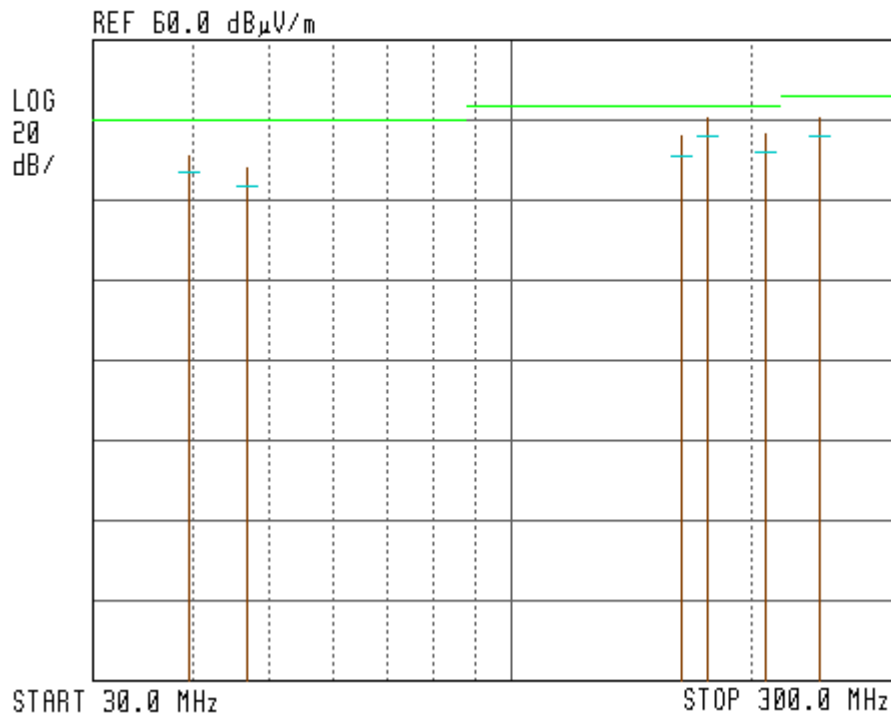

**Figure 168. Radiated Emission. Antenna Polarization: HORIZONTAL
Detectors: Peak, Quasi-peak**

Note:

1. Horizontal axis shows logarithmic frequency scale.
2. The vertical axis shows amplitude (in dB μ V/m).
3. Peak detection is designated by the top of each vertical line.
4. Quasi-peak detection is designated by the first dash mark (from the top) of each vertical line.

Radiated Emission

E.U.T Description WLAN Module With WCE (WiFi Coverage Extender) for DAS With Four Cisco 1242 Access Points

Type 860M With WCE

Serial Number: 1. 860M: 73903D
 2. WCE: 739038

Specification: FCC Part 15, Subpart C

Antenna Polarization: Vertical
 Antenna: 3 meters distance

Frequency range: 30 MHz to 300 MHz
 Detectors: Peak, Quasi-peak

Frequency (MHz)	Peak Amp (dB μ V/m)	QP Amp (dB μ V/m)	Correction (dB)	Specification (dB μ V/m)	Margin (dB)
34.93	36.0	32.1	14.7	40.0	-7.9
39.70	41.6	36.5	13.4	40.0	-3.5
46.15	44.4	34.8	12.2	40.0	-5.2
162.58	41.6	38.8	15.4	43.5	-4.7
175.07	40.9	37.6	15.9	43.5	-5.9
242.11	38.6	34.7	20.0	46.0	-11.3

**Figure 169. Radiated Emission. Antenna Polarization: VERTICAL.
 Detectors: Peak, Quasi-peak**

Note: Margin refers to the test results obtained minus specified requirement; thus a positive number indicates failure, and a negative result indicates that the product passes the test.

Radiated Emission

E.U.T Description WLAN Module With WCE (WiFi Coverage Extender) for DAS With Four Cisco 1242 Access Points
 Type 860M With WCE
 Serial Number: 1. 860M: 73903D
 2. WCE: 739038

Specification: FCC Part 15, Subpart C

Antenna Polarization: Vertical
 Antenna: 3 meters distance

Frequency range: 30 MHz to 300 MHz
 Detectors: Peak, Quasi-peak

 12:34:02 FEB 04, 2008

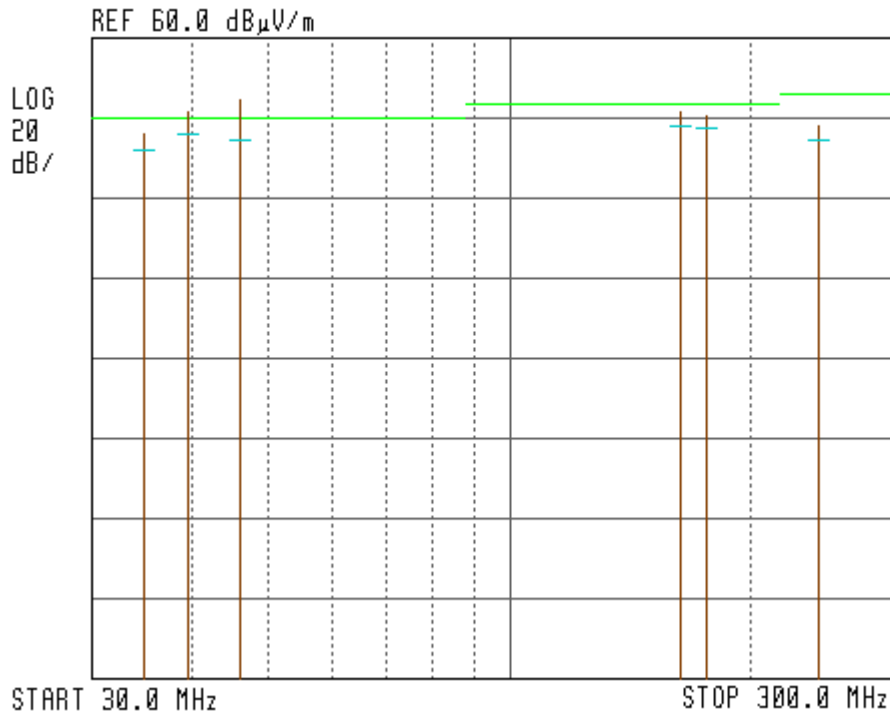

Figure 170. Radiated Emission. Antenna Polarization: VERTICAL. Detectors: Peak, Quasi-peak

Note:

1. Horizontal axis shows logarithmic frequency scale.
2. The vertical axis shows amplitude (in dB μ V/m).
3. Peak detection is designated by the top of each vertical line.
4. Quasi-peak detection is designated by the first dash mark (from the top) of each vertical line.

15.4 Test Instrumentation Used, Radiated Measurements

Instrument	Manufacturer	Model	Serial Number	Calibration	Period
EMI Receiver	HP	85422E	3411A00102	November 12, 2007	1 year
RF Section	HP	85420E	3427A00103	November 12, 2007	1 year
Antenna Bioconical	ARA	BCD 235/B	1041	March 22, 2007	1 year
Antenna Log Periodic	ARA	LPD-2010/A	1038	November 22, 2007	1 year
Active Loop Antenna	EMCO	6502	9506-2950	October 15, 2007	1 year
Antenna Mast	ARA	AAM-4A	1001	N/A	N/A
Turntable	ARA	ART-1001/4	1001	N/A	N/A
Mast & Table Controller	ARA	ACU-2/5	1001	N/A	N/A
Printer	HP	LaserJet 2200	JPKG19982	N/A	N/A

15.5 *Field Strength Calculation*

The field strength is calculated directly by the EMI Receiver software, and a "Correction Factors" data disk, using the following equation:

$$[\text{dB}\mu\text{v}/\text{m}] \text{ FS} = \text{RA} + \text{AF} + \text{CF}$$

- FS: Field Strength [dB μ v/m]
- RA: Receiver Amplitude [dB μ v]
- AF: Receiving Antenna Correction Factor [dB/m]
- CF: Cable Attenuation Factor [dB]

No external pre-amplifiers are used.

16. Spurious Radiated Emission in the Restricted Band, Above 1 GHz 2.4GHz Transmitter 802.11b/g + 802.11a + CELL + PCS Signals

16.1 Radiated Emission Above 1 GHz

The E.U.T operation mode and test set-up are as described in Section 3.

See Section 3.1 Justification of the System Test Configuration concerning the E.U.T. orientation for this test.

A preliminary measurement to characterize the E.U.T was performed inside the shielded room, using peak detection mode and broadband antennas. The preliminary measurements produced a list of the highest emissions. The E.U.T was then transferred to the open site, and placed on a remote-controlled turntable. The E.U.T was placed on a non-metallic table, 0.8 meters above the ground. The configuration tested is shown in Figure 3.1.

The levels of the emissions within the frequency ranges of the restricted bands (Section 15.205 of FCC Part 15) were compared to the limits of the table in Section 15.209 (a), General Requirements.

In the frequency range 1-2.9 GHz, a computerized EMI receiver complying to CISPR 16 requirements was used.

In the frequency range 2.9-25.0 GHz, a spectrum analyzer including a low noise amplifier was used. During average measurements, the IF bandwidth was 1 MHz and the video bandwidth was 100Hz. During peak measurements, the IF bandwidth was 1 MHz and the video bandwidth was 3 MHz.

The test distance was 3 meters.

The readings were maximized by adjusting the antenna height between 1-4 meters, the turntable azimuth between 0-360°, and the antenna polarization.

Verification of the E.U.T emissions was based on the following methods: turning the E.U.T on and off; using a frequency span less than 10 MHz; observation of the signal level during turntable rotation. (Background noise is not affected by the rotation of the E.U.T.)

The E.U.T. was tested at the operating frequencies of 2412, 2437, and 2462 MHz using the following modulations: DBPSK, BPSK, CCK, and 64QAM.

16.2 Test Data

JUDGEMENT: Passed by 11.4 dB

For the operation frequency of 2412 MHz, the margin between the emission level and the specification limit is 11.5 dB in the worst case at the frequency of 4824.00 MHz, vertical polarization.

For the operation frequency of 2437 MHz, the margin between the emission level and the specification limit is 11.4 dB in the worst case at the frequency of 4874.00 MHz, vertical polarization.

For the operation frequency of 2462 MHz, the margin between the emission level and the specification limit is 15.1 dB in the worst case at the frequency of 4924.00 MHz, vertical polarization.

The results for all modulations were the same.

The EUT met the requirements of the F.C.C. Part 15, Subpart C, specification.

TEST PERSONNEL:

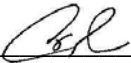
Tester Signature: 

Date: 05.02.08

Typed/Printed Name: A. Sharabi

Radiated Emission Above 1 GHz

E.U.T Description WLAN Module With WCE (WiFi Coverage Extender) for DAS With Four Cisco 1242 Access Points

Type 860M With WCE

Serial Number: 1. 860M: 73903D
 2. WCE: 739038

Specification: FCC, Part 15, Subpart C

Antenna Polarization: Horizontal/Vertical Frequency range: 1.0 GHz to 25.0 GHz
 Test Distance: 3 meters Detector: Peak
 Operation Frequency: 2412 MHz

Freq.	Polarity	Peak Amp	Peak. Specification	Peak. Margin
(MHz)	(H/V)	(dBμV/m)	(dB μV/m)	(dB)
4824.00	H	49.6*	74.0	-24.4
4824.00	V	52.5*	74.0	-21.5

Figure 171. Radiated Emission. Antenna Polarization: HORIZONTAL / VERTICAL. Detector: Peak

Margin refers to the test results obtained minus specified requirement; thus a positive number indicates failure, and a negative result indicates that the product passes the test.

“Peak Amp” includes correction factor.

* “Correction Factor” = Antenna Factor + Cable Loss- Low Noise Amplifier Gain

Radiated Emission Above 1 GHz

E.U.T Description	WLAN Module With WCE (WiFi Coverage Extender) for DAS With Four Cisco 1242 Access Points
Type	860M With WCE
Serial Number:	1. 860M: 73903D 2. WCE: 739038

Specification: FCC, Part 15, Subpart C

Antenna Polarization: Horizontal/Vertical	Frequency range: 1.0 GHz to 25.0 GHz
Test Distance: 3 meters	Detector: Average
Operation Frequency: 2412 MHz	

Freq.	Polarity	Average Amp	Average Specification	Peak. Margin
(MHz)	(H/V)	(dBμV/m)	(dB μV/m)	(dB)
4824.00	H	39.8*	54.0	-14.2
4824.00	V	42.5*	54.0	-11.5

Figure 172. Radiated Emission. Antenna Polarization: HORIZONTAL / VERTICAL. Detector: Average

Notes:

Margin refers to the test results obtained minus specified requirement; thus a positive number indicates failure, and a negative result indicates that the product passes the test.

“Average Amp” includes correction factor.

* Correction Factor = Antenna Factor + Cable Loss- Low Noise Amplifier Gain

Radiated Emission Above 1 GHz

E.U.T Description WLAN Module With WCE (WiFi Coverage Extender) for DAS With Four Cisco 1242 Access Points

Type 860M With WCE

Serial Number: 1. 860M: 73903D
 2. WCE: 739038

Specification: FCC, Part 15, Subpart C

Antenna Polarization: Horizontal/Vertical Frequency range: 1.0 GHz to 25.0 GHz
 Test Distance: 3 meters Detector: Peak
 Operation Frequency: 2437 MHz

Freq.	Polarity	Peak Amp	Peak. Specification	Peak. Margin
(MHz)	(H/V)	(dB μ V/m)	(dB μ V/m)	(dB)
4874.00	H	46.1*	74.0	-27.9
4874.00	V	49.3*	74.0	-24.7

Figure 173. Radiated Emission. Antenna Polarization: HORIZONTAL / VERTICAL. Detector: Peak

Margin refers to the test results obtained minus specified requirement; thus a positive number indicates failure, and a negative result indicates that the product passes the test.

“Peak Amp” includes correction factor.

* “Correction Factor” = Antenna Factor + Cable Loss- Low Noise Amplifier Gain

Radiated Emission Above 1 GHz

E.U.T Description WLAN Module With WCE (WiFi Coverage Extender) for DAS With Four Cisco 1242 Access Points

Type 860M With WCE

Serial Number: 1. 860M: 73903D
 2. WCE: 739038

Specification: FCC, Part 15, Subpart C

Antenna Polarization: Horizontal/Vertical Frequency range: 1.0 GHz to 25.0 GHz

Test Distance: 3 meters Detector: Average

Operation Frequency: 2437 MHz

Freq.	Polarity	Average Amp	Average Specification	Peak. Margin
(MHz)	(H/V)	(dBμV/m)	(dB μV/m)	(dB)
4874.00	H	37.5*	54.0	-16.5
4874.00	V	42.6*	54.0	-11.4

Figure 174. Radiated Emission. Antenna Polarization: HORIZONTAL / VERTICAL. Detector: Average

Notes:

Margin refers to the test results obtained minus specified requirement; thus a positive number indicates failure, and a negative result indicates that the product passes the test.

“Average Amp” includes correction factor.

* Correction Factor = Antenna Factor + Cable Loss- Low Noise Amplifier Gain

Radiated Emission Above 1 GHz

E.U.T Description WLAN Module With WCE (WiFi Coverage Extender) for DAS With Four Cisco 1242 Access Points

Type 860M With WCE

Serial Number: 1. 860M: 73903D
 2. WCE: 739038

Specification: FCC, Part 15, Subpart C

Antenna Polarization: Horizontal/Vertical Frequency range: 1.0 GHz to 25.0 GHz
 Test Distance: 3 meters Detector: Peak
 Operation Frequency: 2462 MHz

Freq.	Polarity	Peak Amp	Peak. Specification	Peak. Margin
(MHz)	(H/V)	(dBμV/m)	(dB μV/m)	(dB)
4924.00	H	45.6*	74.0	-28.4
4924.00	V	47.2*	74.0	-26.8

Figure 175. Radiated Emission. Antenna Polarization: HORIZONTAL / VERTICAL. Detector: Peak

Margin refers to the test results obtained minus specified requirement; thus a positive number indicates failure, and a negative result indicates that the product passes the test.

“Peak Amp” includes correction factor.

* “Correction Factor” = Antenna Factor + Cable Loss- Low Noise Amplifier Gain

Radiated Emission Above 1 GHz

E.U.T Description WLAN Module With WCE (WiFi Coverage Extender) for DAS With Four Cisco 1242 Access Points

Type 860M With WCE

Serial Number: 1. 860M: 73903D
 2. WCE: 739038

Specification: FCC, Part 15, Subpart C

Antenna Polarization: Horizontal/Vertical Frequency range: 1.0 GHz to 25.0 GHz

Test Distance: 3 meters Detector: Average

Operation Frequency: 2462 MHz

Freq.	Polarity	Average Amp	Average Specification	Peak. Margin
(MHz)	(H/V)	(dB μ V/m)	(dB μ V/m)	(dB)
4924.00	H	36.7*	54.0	-17.3
4924.00	V	38.9*	54.0	-15.1

Figure 176. Radiated Emission. Antenna Polarization: HORIZONTAL / VERTICAL. Detector: Average

Notes:

Margin refers to the test results obtained minus specified requirement; thus a positive number indicates failure, and a negative result indicates that the product passes the test.

“Average Amp” includes correction factor.

* Correction Factor = Antenna Factor + Cable Loss- Low Noise Amplifier Gain

16.3 Test Instrumentation Used, Radiated Measurements Above 1 GHz

Instrument	Manufacturer	Model	Serial Number	Calibration	Period
Receiver	HP	85422E	3411A00102	November 12, 2007	1 year
RF Section	HP	85420E	3427A00103	November 12, 2007	1 year
Antenna Mast	ARA	AAM-4A	1001	N/A	N/A
Turntable	ARA	ART-1001/4	1001	N/A	N/A
Mast & Table Controller	ARA	ACU-2/5	1001	N/A	N/A
Printer	HP	LaserJet 2200	JPKG19982	N/A	N/A
Antenna-Log Periodic	A.H.System	SAS-200/511	253	February 4, 2007	2 years
Double Ridged Waveguide Horn Antenna	EMCO	3115	29845	March 15, 2006	2 years
Horn Antenna	ARA	SWH-28	1008	December 8, 2006	2 year
Low Noise Amplifier	DBS MICROWAVE	LNA-DBS-0411N313	013	November 2, 2007	1 year
Low Noise Amplifier	Sophia Wireless	LNA 28-B	232	February 8, 2007	1 year
Low Noise Amplifier	MK Milliwave	MKT6-3000 400-30-13P	399	February 8, 2007	1 year
Spectrum Analyzer	HP	8592L	3826A01204	February 22, 2007	1 year
Spectrum Analyzer	HP	8546E	3442A00275	November 14, 2007	1 year
Printer	HP	LaserJet 2200	JPKG19982	N/A	N/A

17. 26 dB Bandwidth 2.4 GHz Transmitter 802.11b/g + 802.11a + CELL + PCS Signals

17.1 Test procedure

The E.U.T. was set to the applicable test frequency. The E.U.T. antenna terminal was connected to the spectrum analyzer through an external attenuator (20 dB) and appropriate coaxial cable (cable loss = 0.5 dB). The spectrum analyzer was set to 100 kHz resolution BW. The spectrum bandwidth of the E.U.T. was measured and recorded.

The E.U.T. was tested at 2412, 2437, and 2462 MHz with the following modulations: DBPSK (1Mbit/sec), BPSK (6Mbit/sec), CCK (11Mbit/sec) and 64QAM (54Mbit/sec).

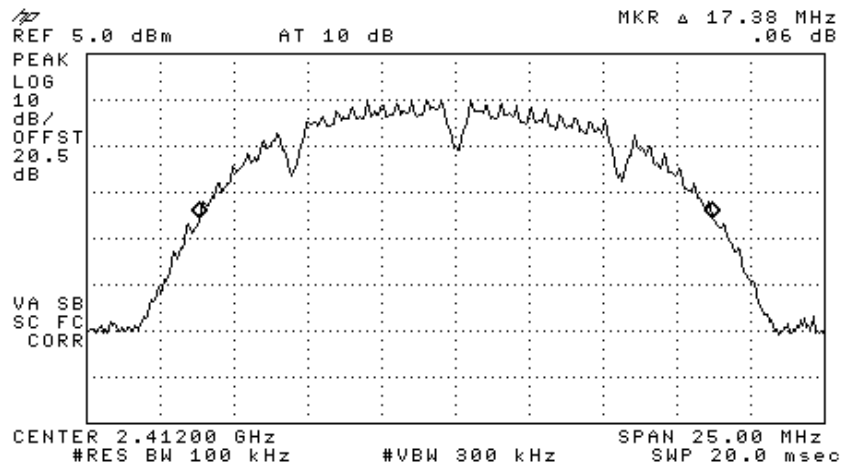

Figure 177 —2412 MHz DBPSK

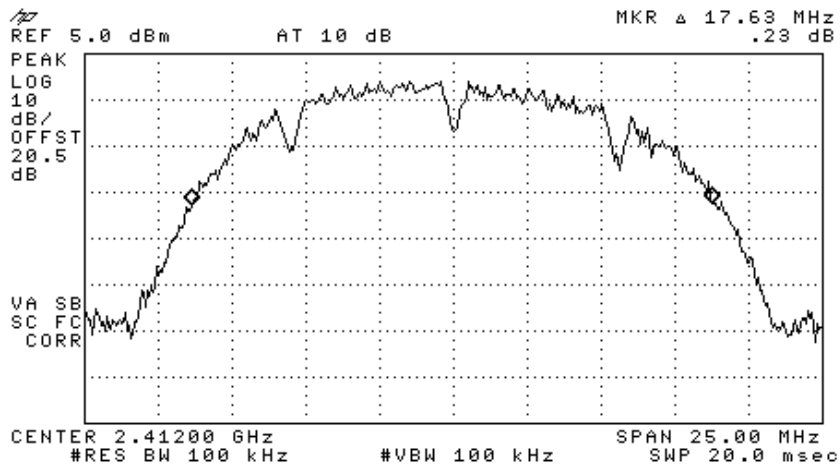

Figure 178 —2412 MHz BPSK

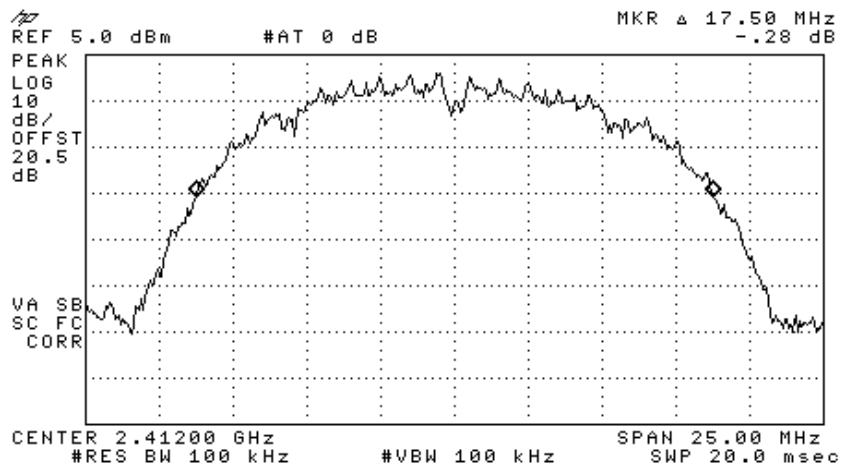

Figure 179 —2412 MHz CCK

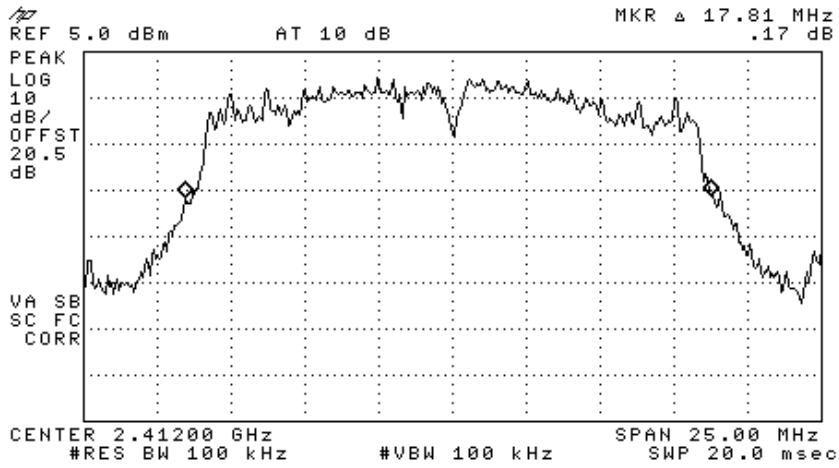

Figure 180 —2412 MHz 64QAM

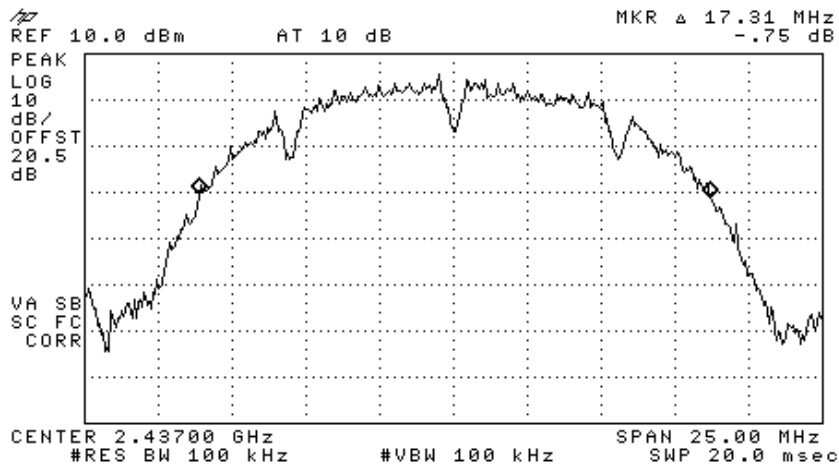

Figure 181 —2437 MHz DBPSK

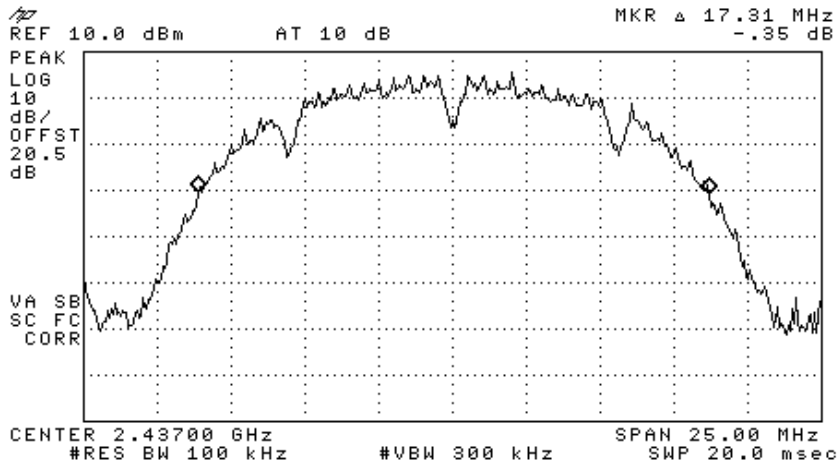

Figure 182 —2437 MHZ BPSK

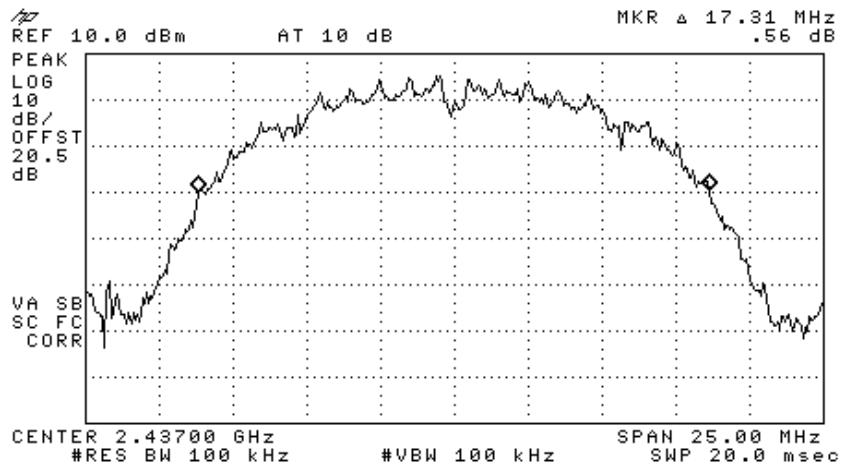

Figure 183 —2437 MHz CCK

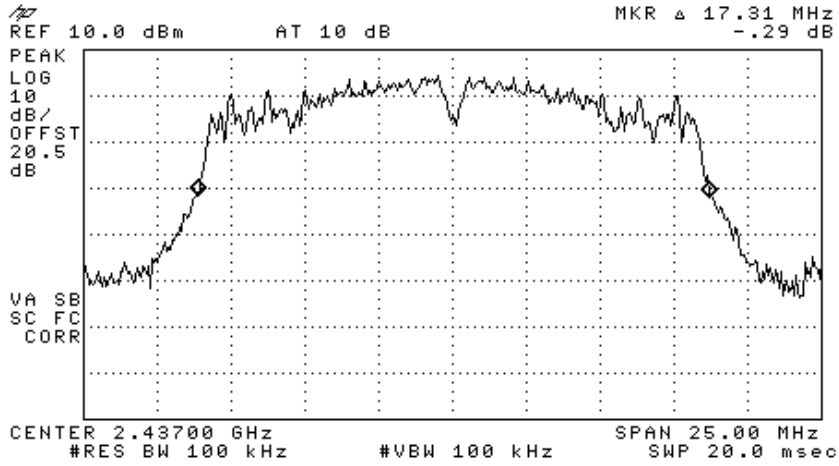

Figure 184 —2437 MHz 64QAM

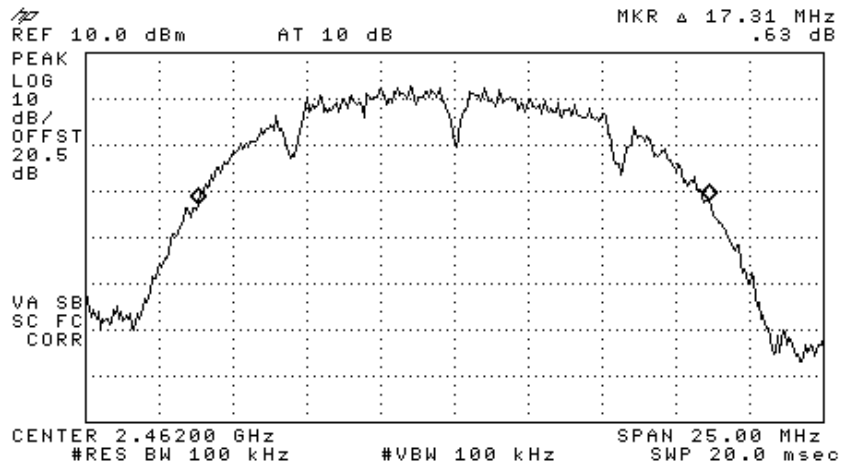

Figure 185 —2462 MHz DBPSK

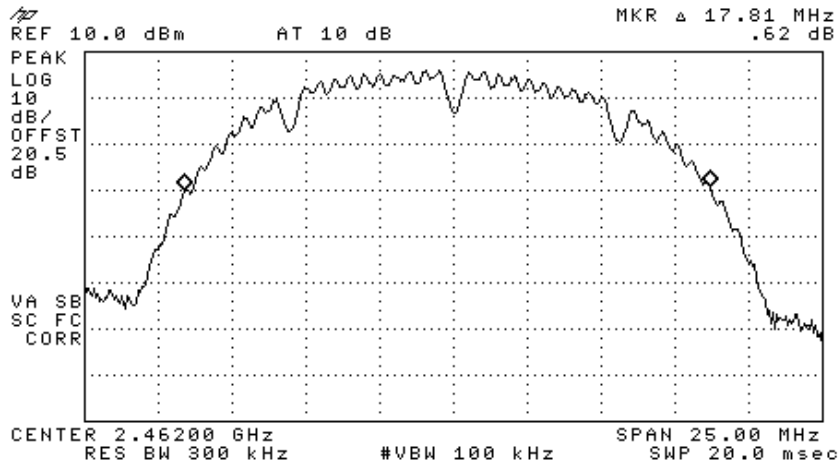

Figure 186 —2462 MHz BPSK

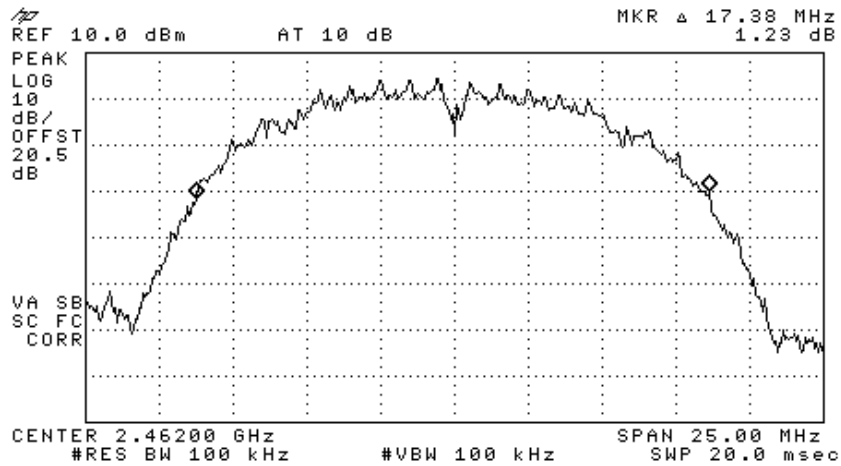

Figure 187 —2462 MHz CCK

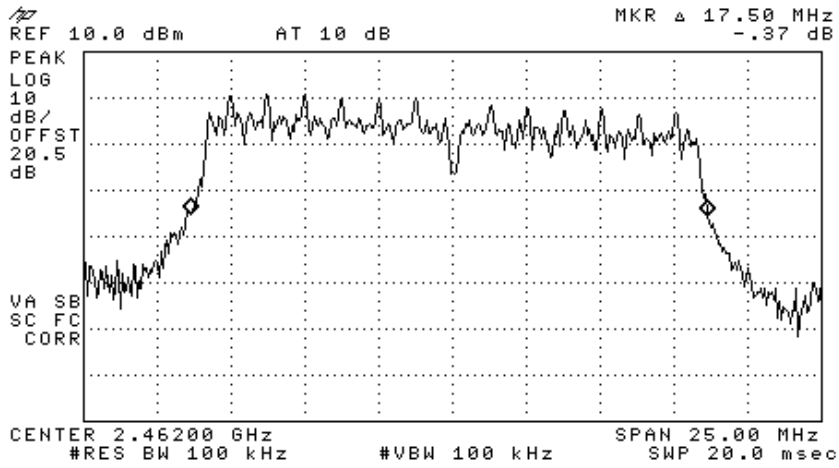

Figure 188 —2462 MHZ 64QAM

Operation Frequency (MHz)	Modulation	26 dB Bandwidth (dBm)
2412	DBPSK	17.38
	BPSK	17.68
	CCK	17.50
	64QAM	17.81
2437	DBPSK	17.31
	BPSK	17.31
	CCK	17.31
	64QAM	17.31
2462	DBPSK	17.31
	BPSK	17.81
	CCK	17.38
	64QAM	17.50

TEST PERSONNEL:

Tester Signature: *E. Pitt*

Date: 05.02.08

Typed/Printed Name: E. Pitt

17.2 Test Equipment Used.

26 dB Minimum Bandwidth

Instrument	Manufacturer	Model	Serial/Part Number	Calibration	
				Last Calibr.	Period
Spectrum Analyzer	HP	8592L	3826A01204	February 22, 2007	1 year
Attenuator	Jyebao	-	FAT-AM5AF5G6G2W20	May 9, 2007	1 year
Cable	Rhophase	KPS-5000-KPS	A1674	February 8, 2007	1 year

Figure 189 Test Equipment Used

18. Maximum Transmitted Peak Power Output 2.4 GHz Transmitter 802.11b/g + 802.11a + CELL + PCS Signals

18.1 Test procedure

The E.U.T. antenna terminal was connected to the Spectrum Analyzer through an external attenuator (20 dB) and an appropriate coaxial cable (cable loss = 0.5 dB). The Spectrum Analyzer was set to 1.0 MHz resolution BW. Peak power level was measured at selected operation frequencies.

The E.U.T. was tested at 2412, 2437, and 2462 MHz with the following modulations: DBPSK (1Mbit/sec), BPSK (6Mbit/sec), CCK (11Mbit/sec) and 64QAM (54Mbit/sec).

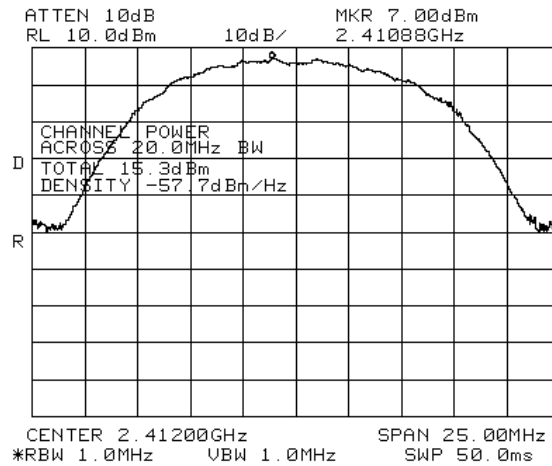

Figure 190 2412 DBPSK

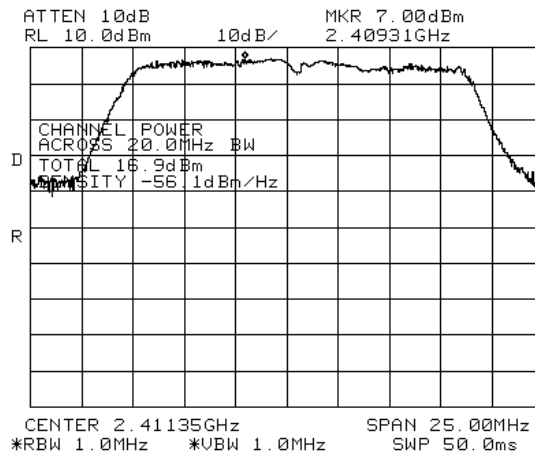

Figure 193 2412 MHz 64QAM

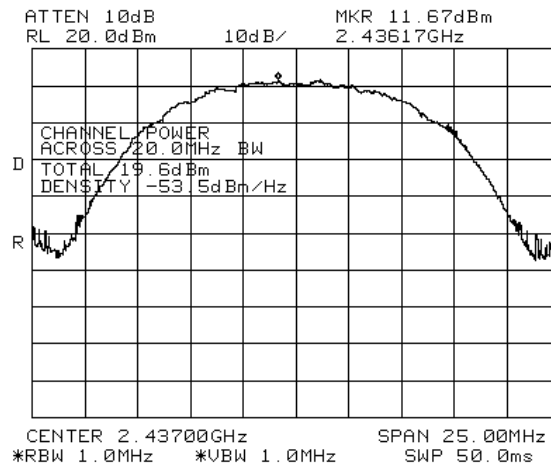

Figure 194 2437 MHz DBPSK

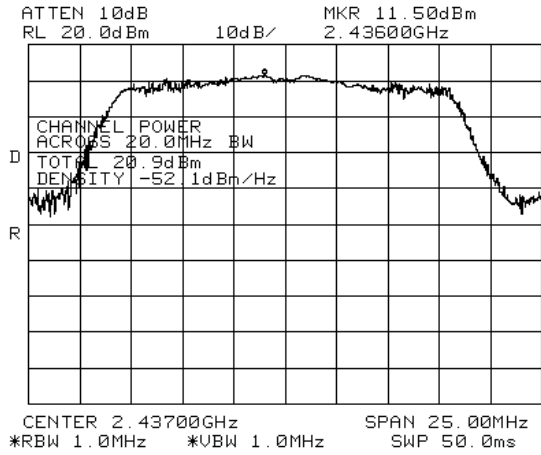

Figure 197 2437 MHz 64QAM

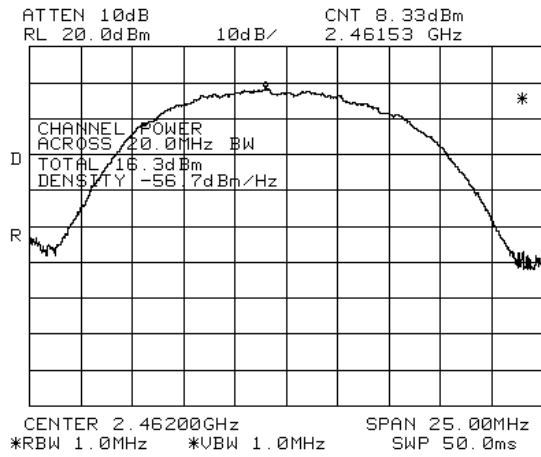

Figure 198 2462 MHz DBPSK

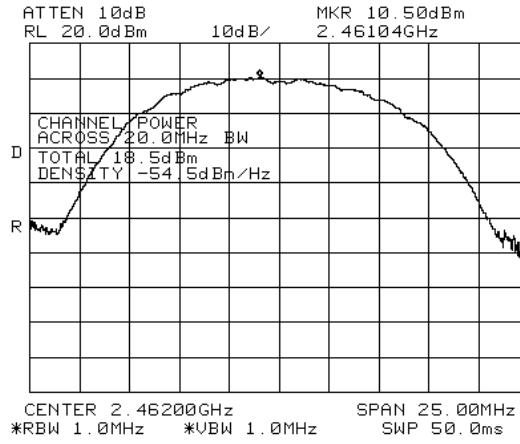

Figure 199 2462 MHz BPSK

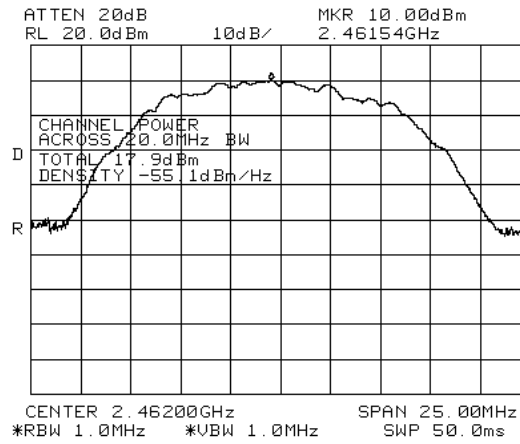

Figure 200 2462 MHz CCK

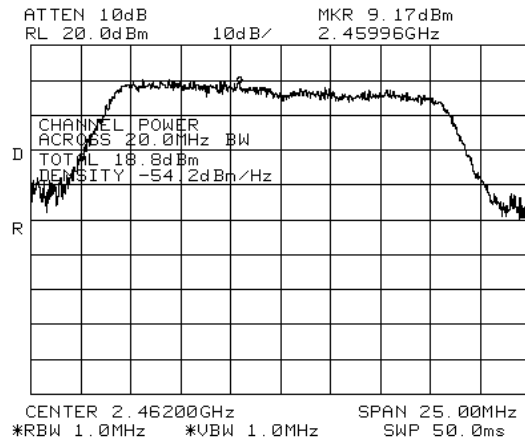

Figure 201 2462 MHz 64QAM

18.2 Results table

E.U.T. Description: WLAN Module With WCE (WiFi Coverage Extender) for DAS
With Four Cisco 1242 Access Points

Model No.: 860M With WCE

Serial Number: 1. 860M: 73903D 2. WCE: 739038

Specification: F.C.C. Part 15, Subpart C

Operation Frequency (MHz)	Modulation	Power (dBm)	Specification (dBm)	Margin (dB)
2412	DBPSK	15.3	29.0	-13.7
	BPSK	15.8	29.0	-13.2
	CCK	16.9	29.0	-12.1
	64QAM	16.9	29.0	-12.1
2437	DBPSK	19.6	29.0	-9.4
	BPSK	20.6	29.0	-8.4
	CCK	21.5	29.0	-7.5
	64QAM	20.9	29.0	-8.1
2462	DBPSK	16.3	29.0	-12.7
	BPSK	18.5	29.0	-10.5
	CCK	17.9	29.0	-11.1
	64QAM	18.8	29.0	-10.2

Figure 202 Maximum Peak Power Output

Note: Antenna Gain is 7 dBi

JUDGEMENT: Passed by 7.5 dB

TEST PERSONNEL:

Tester Signature: 

Date: 05.02.08

Typed/Printed Name: E. Pitt

18.3 Test Equipment Used.

Peak Power Output

Instrument	Manufacturer	Model	Serial/Part Number	Calibration	
				Last Calibr.	Period
Spectrum Analyzer	HP	8564E	3442A00275	November 14, 2007	1 year
Attenuator	Jyebao	-	FAT-AM5AF5G6G2W20	May 9, 2007	1 year
Cable	Rhophase	KPS-5000-KPS	A1674	February 8, 2007	1 year

Figure 203 Test Equipment Used

19. Peak Power Output Out of 2400-2483.5 MHz Band 2.4 GHz Transmitter 802.11b/g + 802.11a + CELL + PCS Signals

19.1 Test procedure

The E.U.T. antenna terminal was connected to the spectrum analyzer through an external attenuator (20 dB) and an appropriate coaxial cable. The spectrum analyzer was set to 100 kHz resolution BW except for the frequency range 9 kHz-150 kHz where the RBW was set to 1kHz and the frequency range 150 kHz-10 MHz where the RBW was set to 10kHz. The frequency range from 9 kHz to 25 GHz was scanned. Level of spectrum components out of the 2400-2483.5 MHz was measured at the selected operation frequencies.

The E.U.T. was tested at 2412, 2437, and 2462 MHz with the following modulations: DBPSK (1Mbit/sec), BPSK (6Mbit/sec), CCK (11Mbit/sec) and 64QAM (54Mbit/sec).

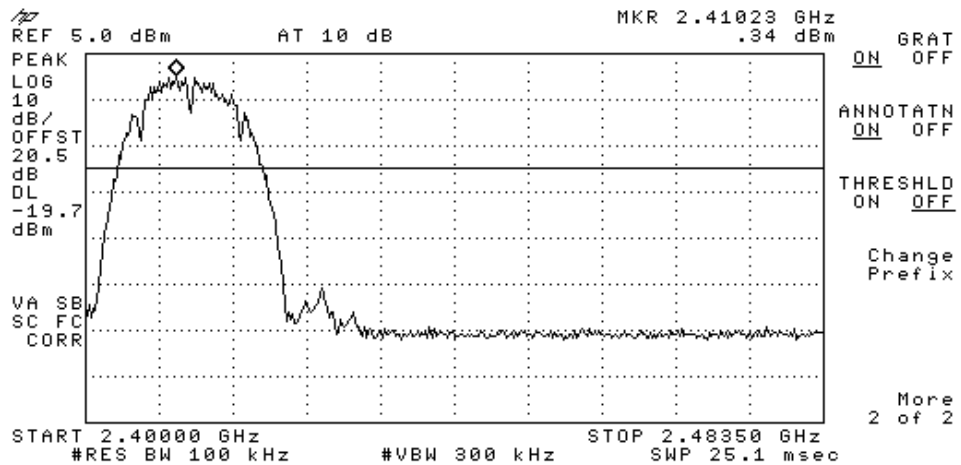

Figure 204 —2412 MHz DBPSK

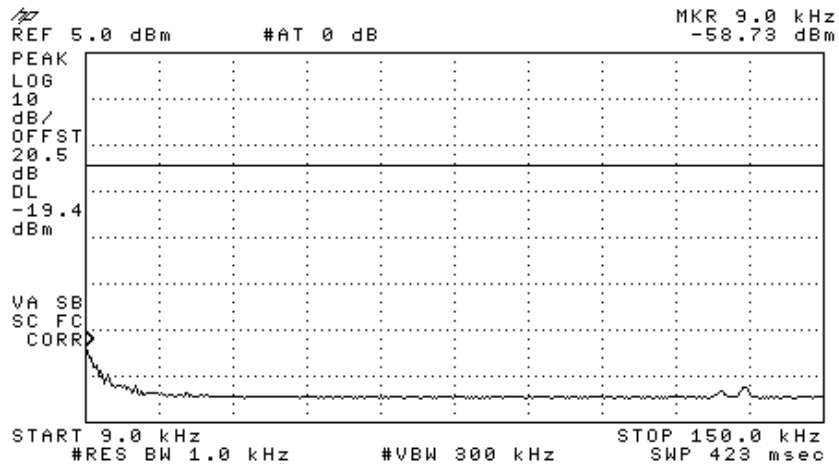

Figure 205 —2412 MHz DBPSK

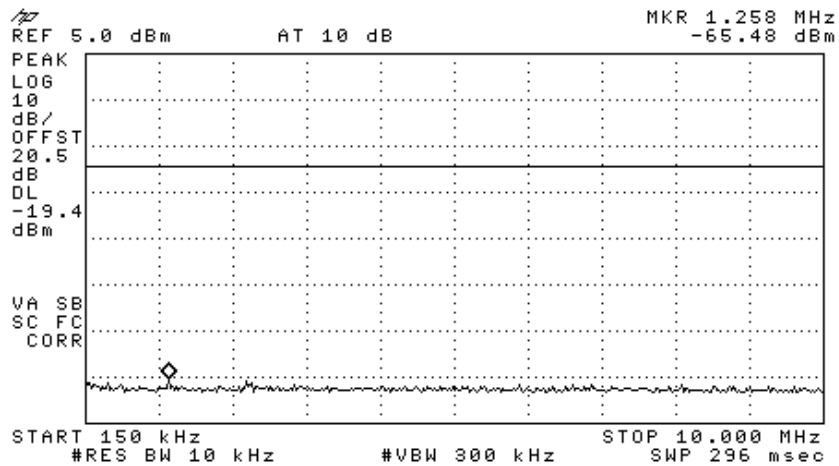

Figure 206 —2412 MHz DBPSK

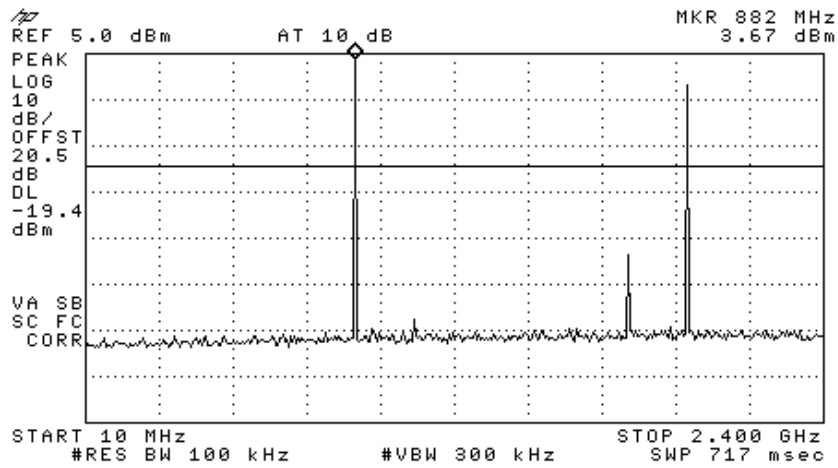

Figure 207 —2412 MHz DBPSK

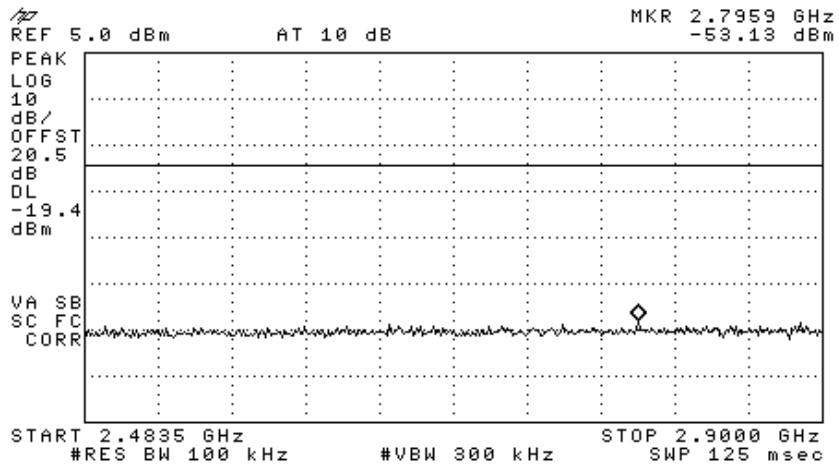

Figure 208 —2412 MHz DBPSK

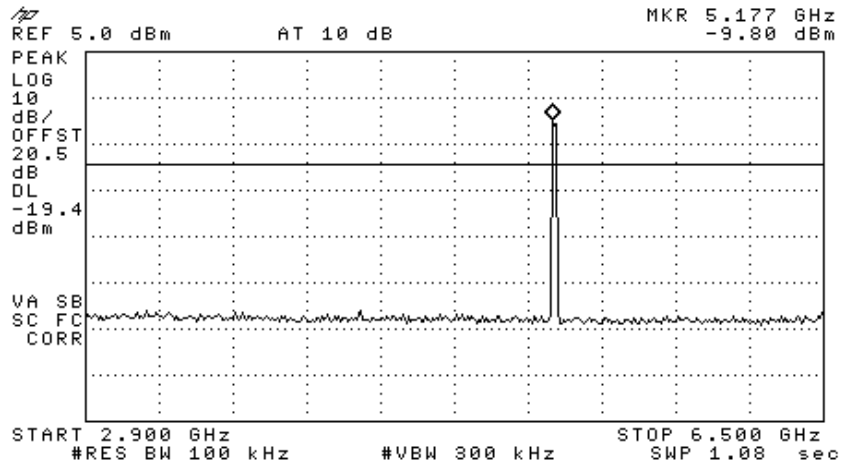

Figure 209 —2412 MHz DBPSK

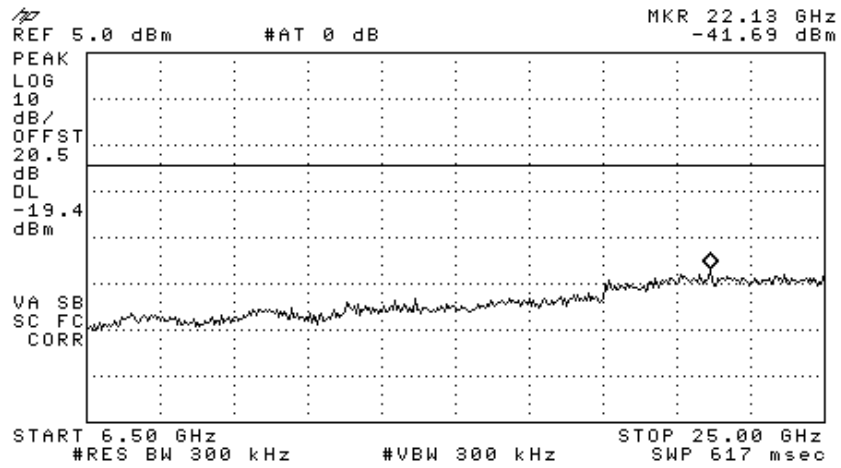

Figure 210 —2412 MHz DBPSK

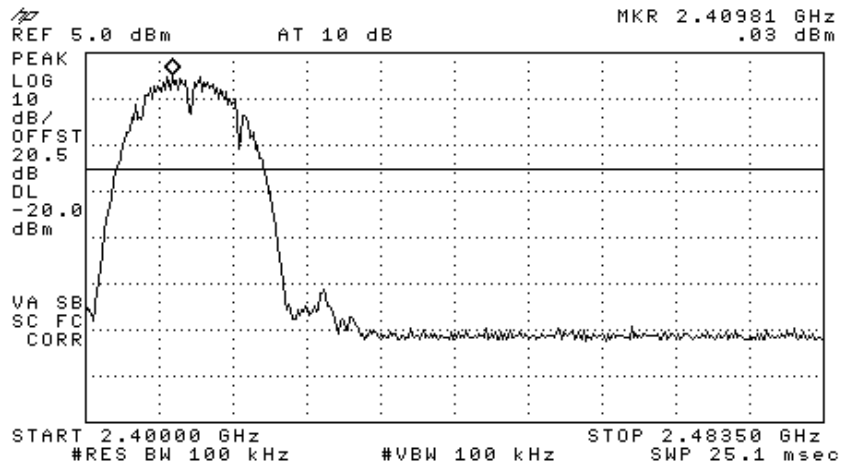

Figure 211 —2412 MHz BPSK

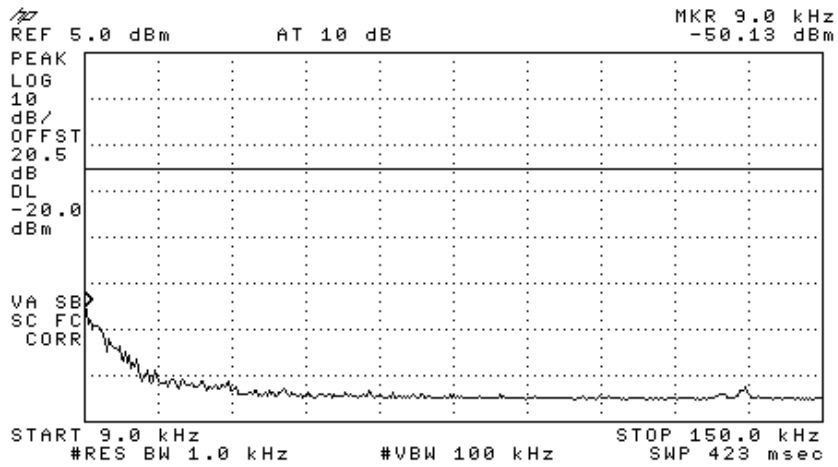

Figure 212 —2412 MHz BPSK

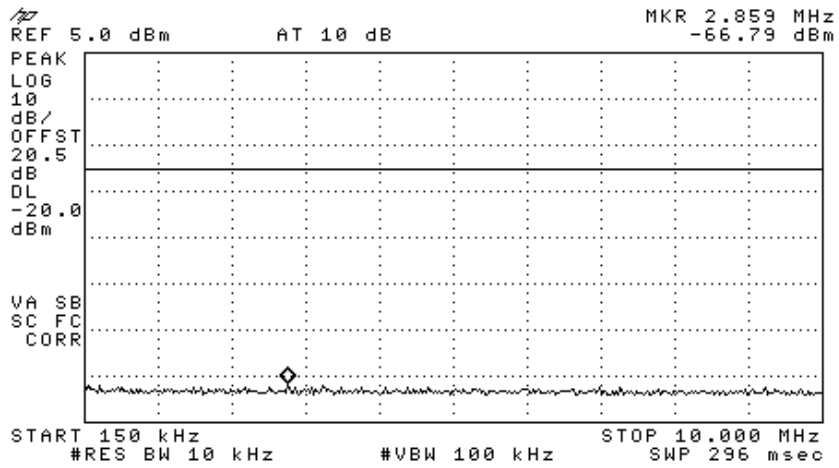

Figure 213 — 2412 MHz BPSK

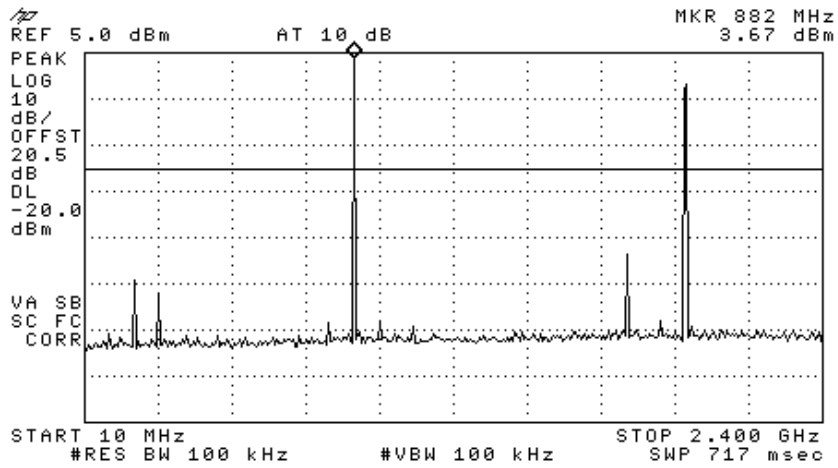

Figure 214 — 2412 MHz BPSK

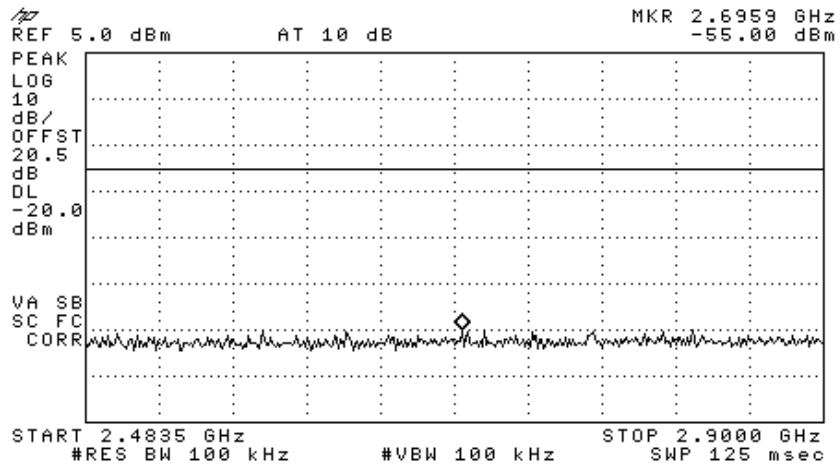

Figure 215 —2412 MHz BPSK

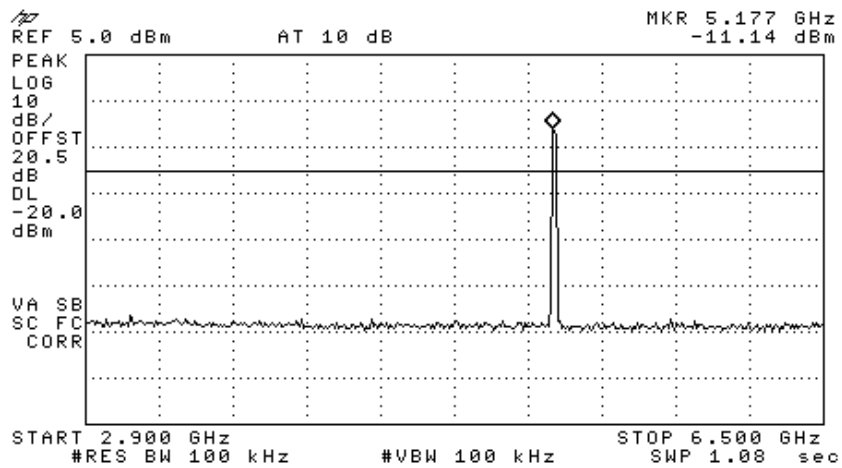

Figure 216 —2412 MHz BPSK

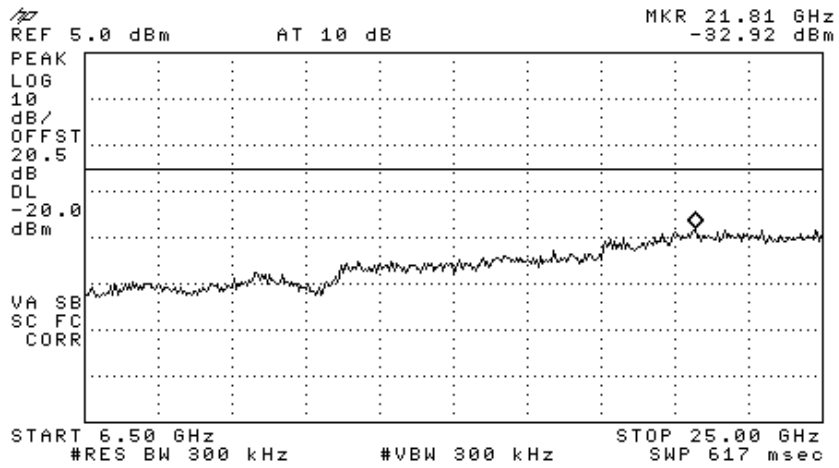

Figure 217 —2412 MHz BPSK

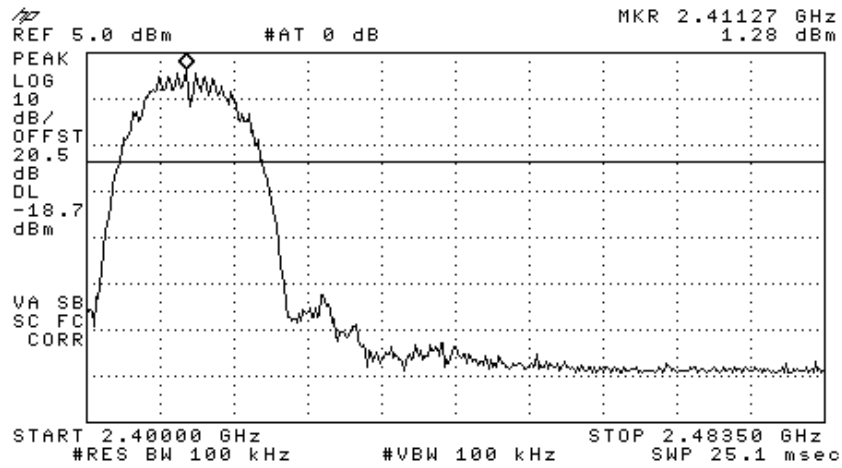

Figure 218 —2412 MHz CCK

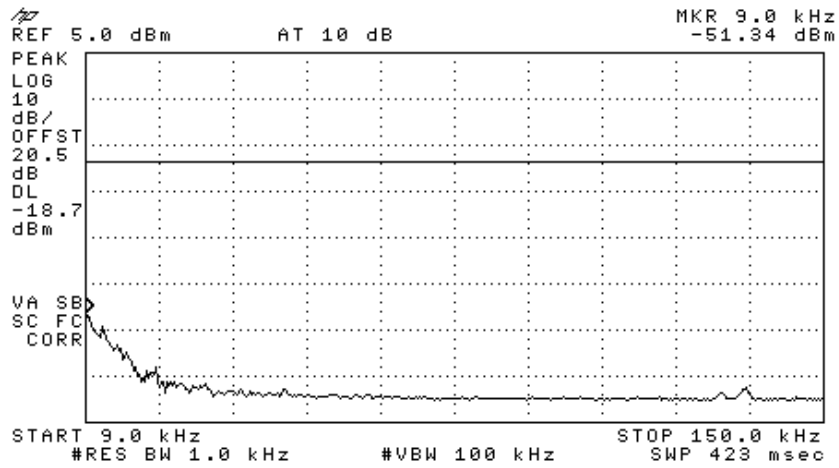

Figure 219 —2412 MHz CCK

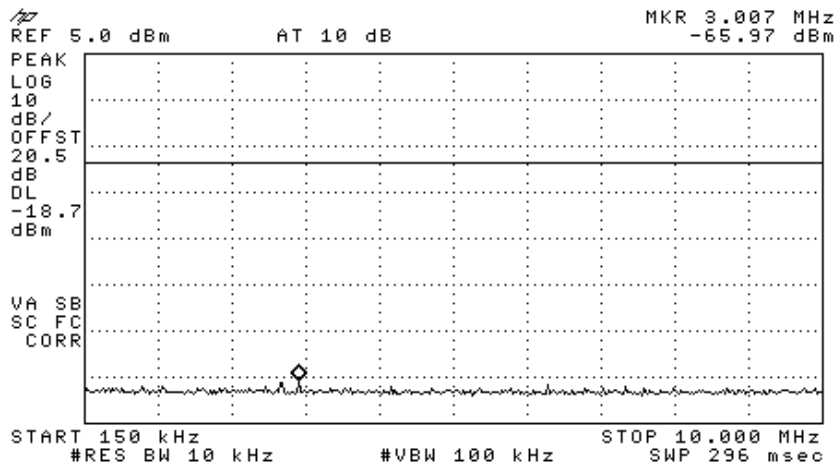

Figure 220 —2412 MHz CCK

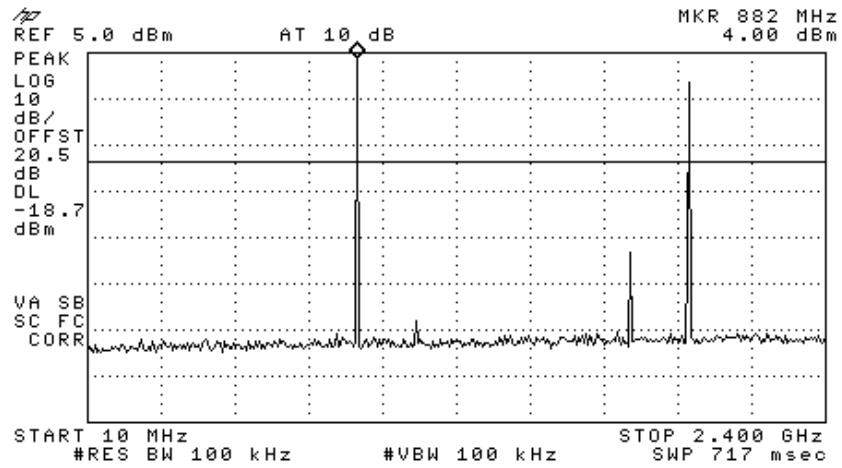

Figure 221 —2412 MHz CCK

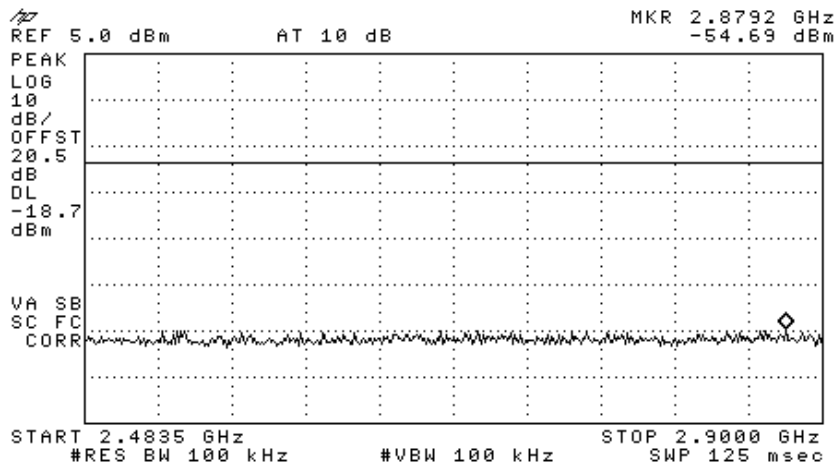

Figure 222 —2412 MHz CCK

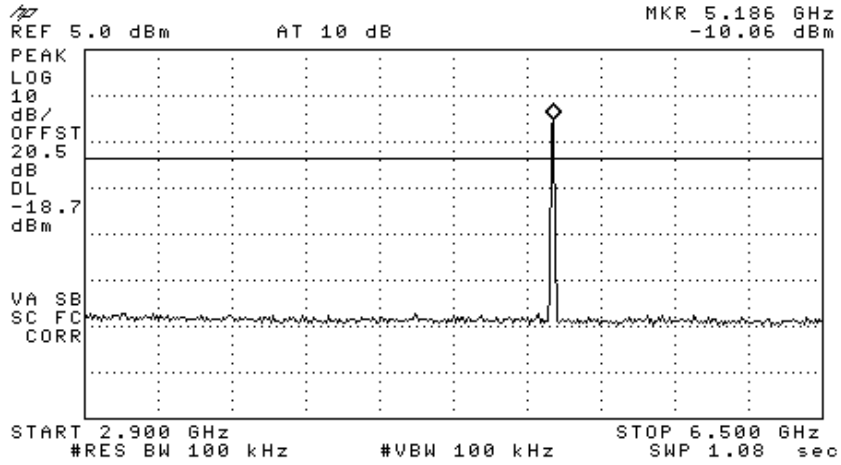

Figure 223 —2412 MHz CCK

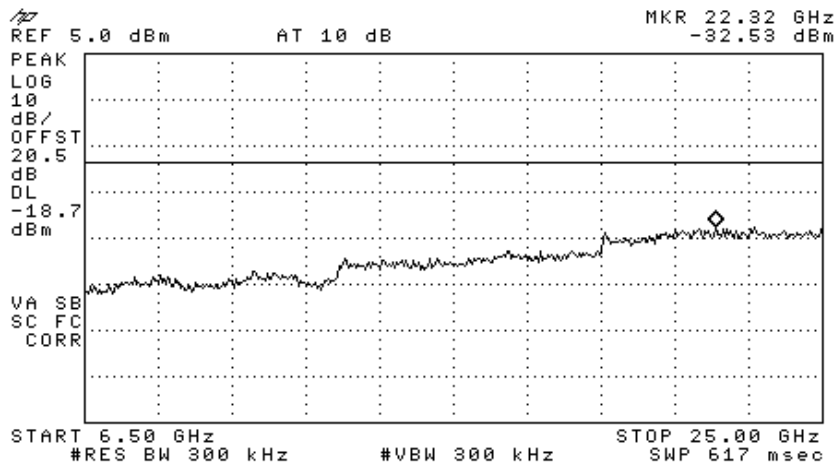

Figure 224 —2412 MHz CCK

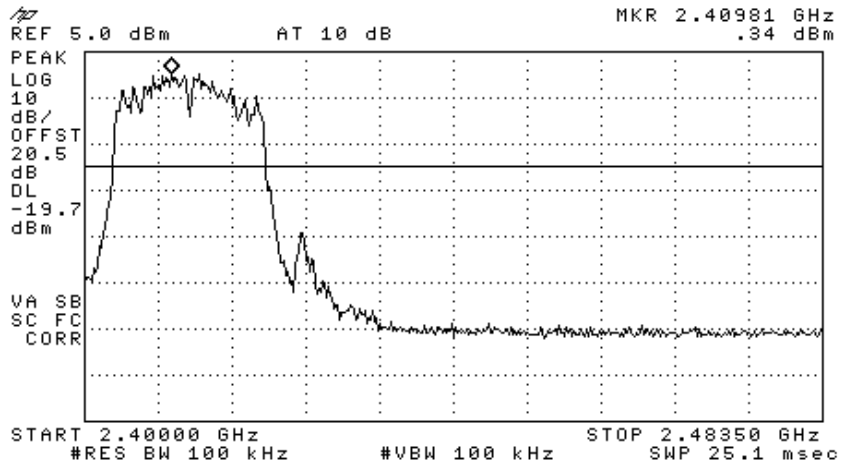

Figure 225 —2412 MHz 64QAM

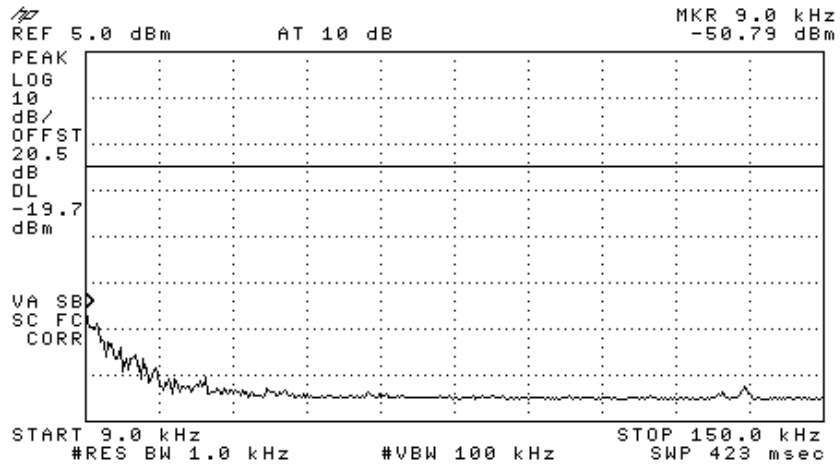

Figure 226 —2412 MHz 64QAM

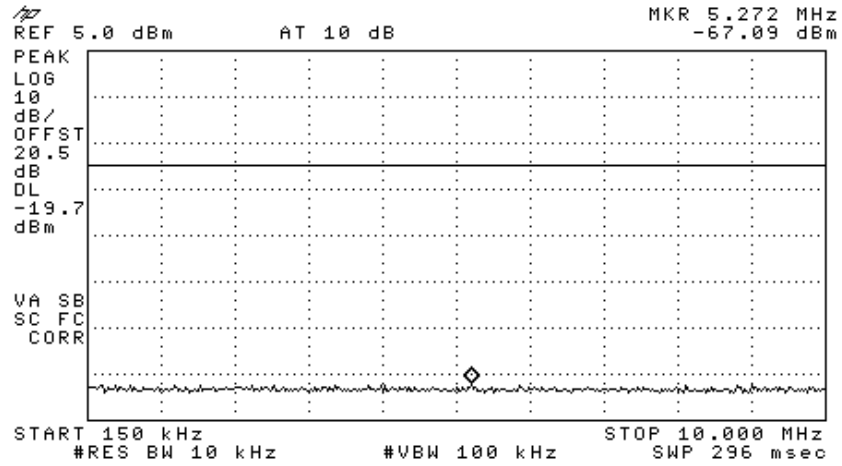

Figure 227 —2412 MHz 64QAM

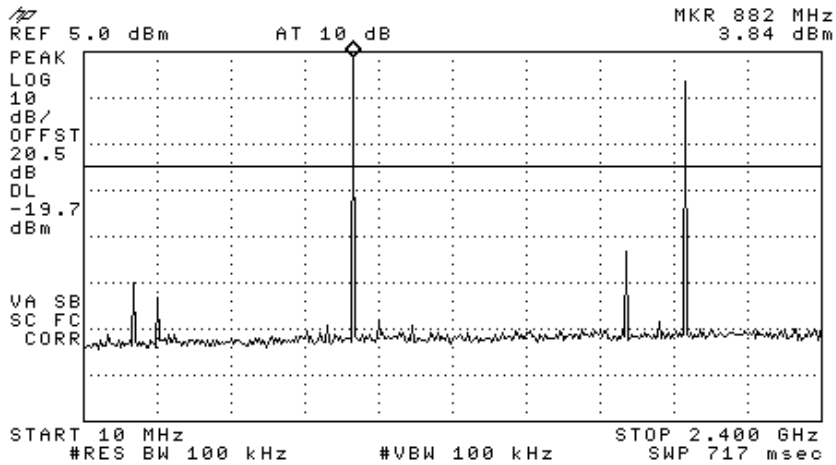

Figure 228 —2412 MHz 64QAM

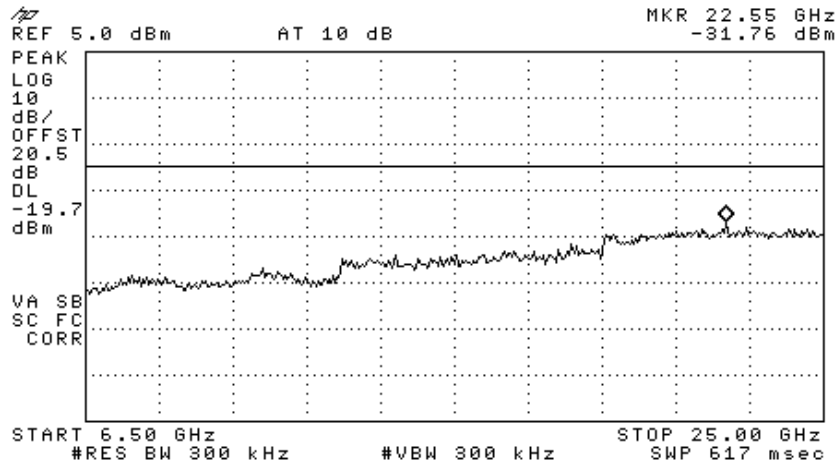

Figure 231 —2412 MHz 64QAM

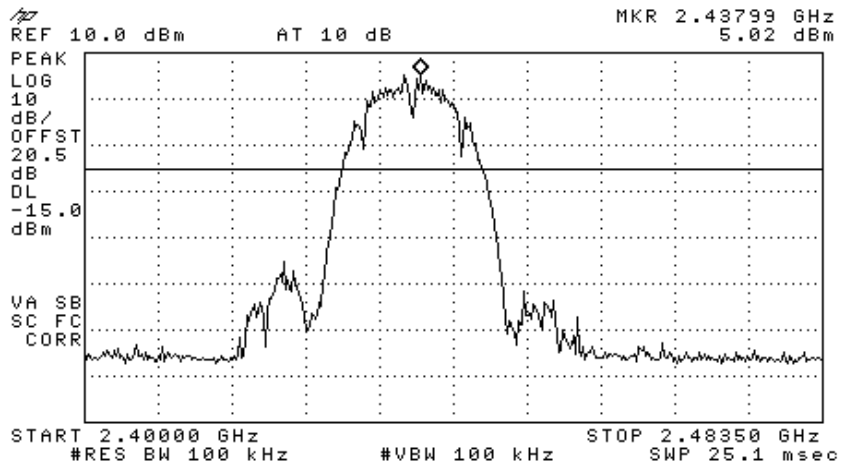

Figure 232 —2437 MHz DBPSK

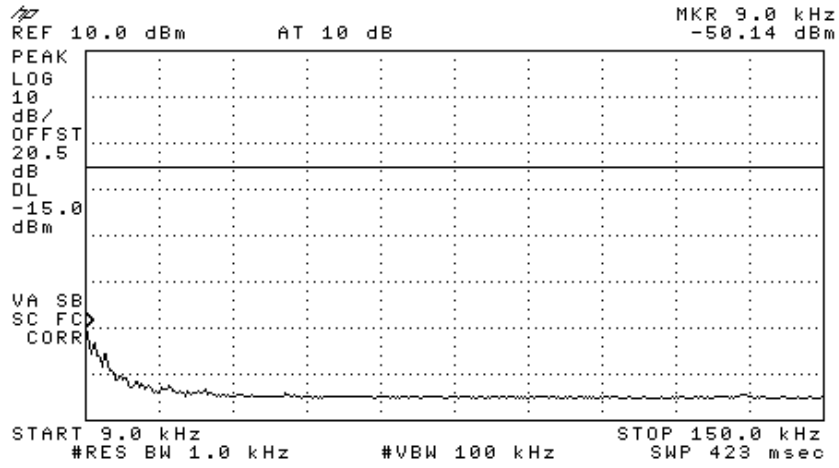

Figure 233 —2437 MHz DBPSK

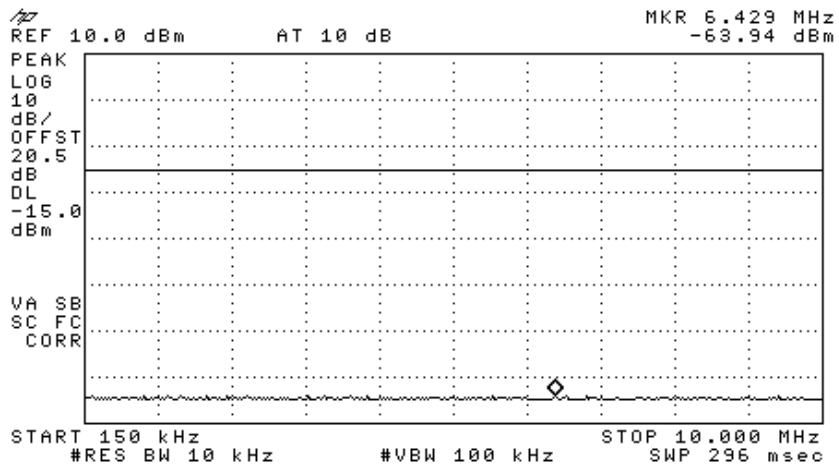

Figure 234 —2437 MHz DBPSK

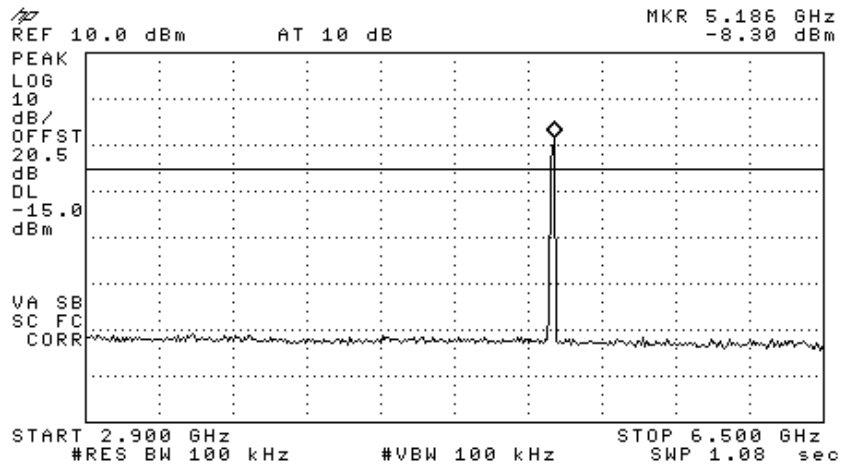

Figure 237 —2437 MHz DBPSK

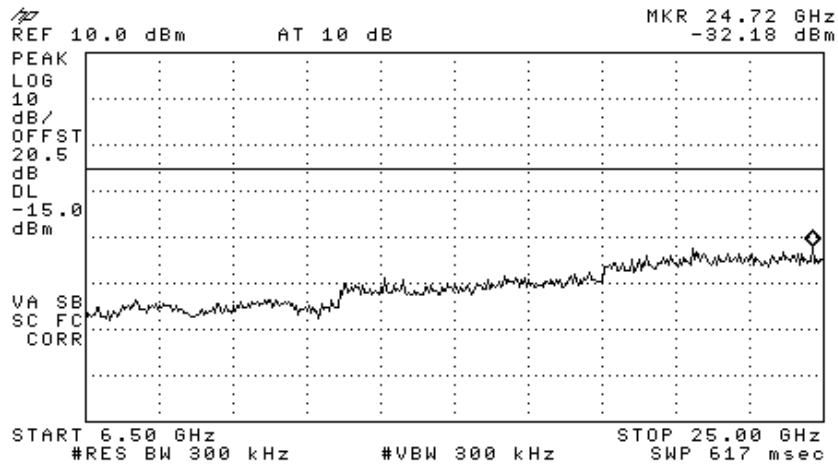

Figure 238 —2437 MHz DBPSK

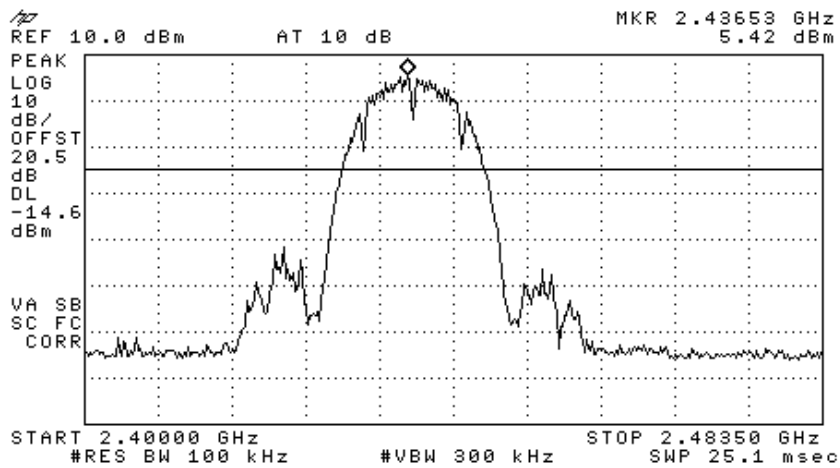

Figure 239 —2437 MHz BPSK

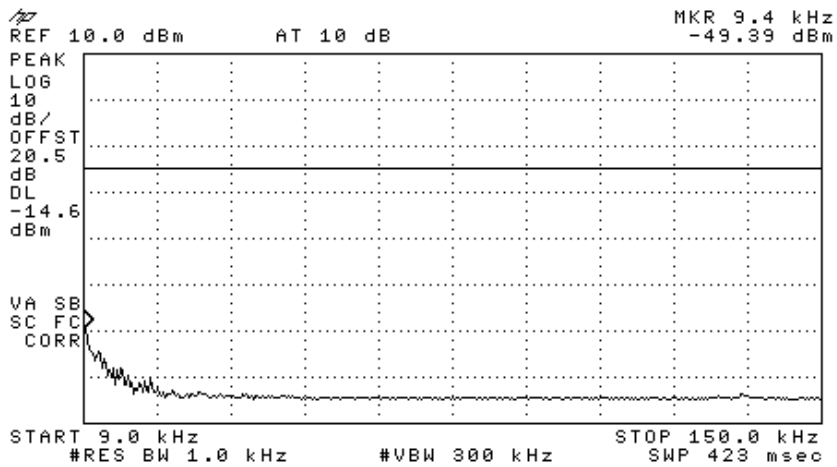

Figure 240 —2437 MHz BPSK

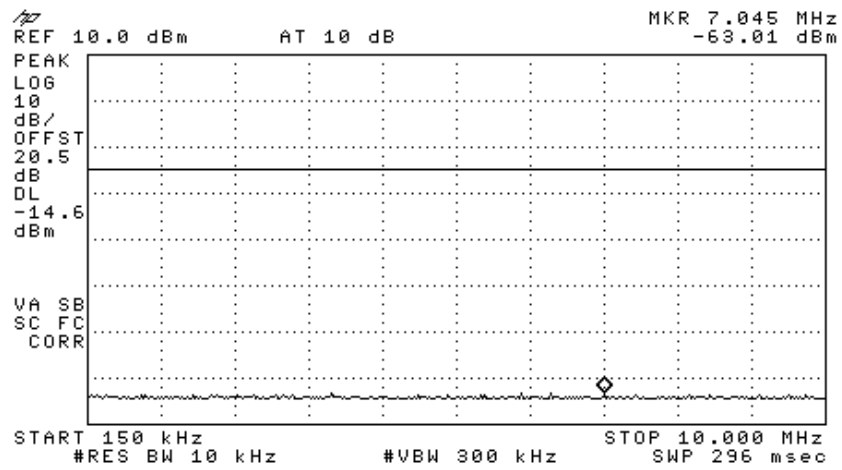

Figure 241 —2437 MHz BPSK

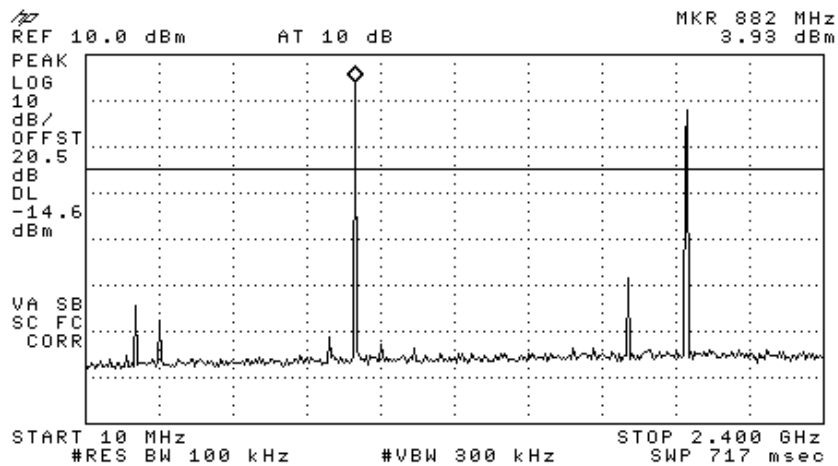

Figure 242 —2437 MHz BPSK

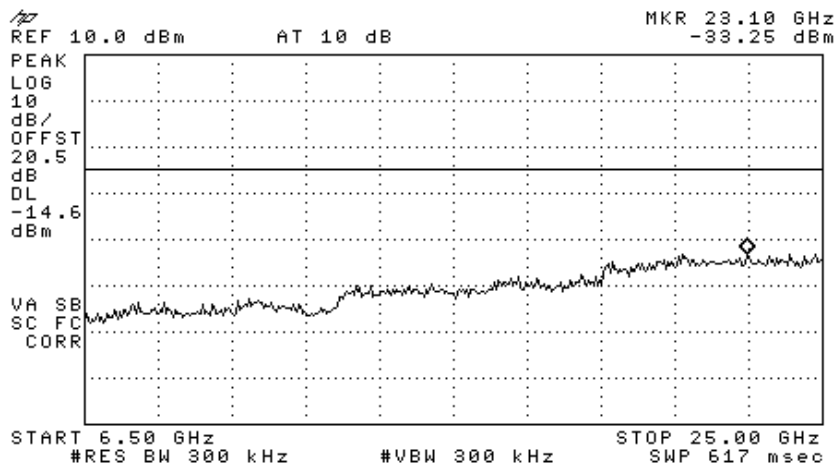

Figure 245 —2437 MHz BPSK

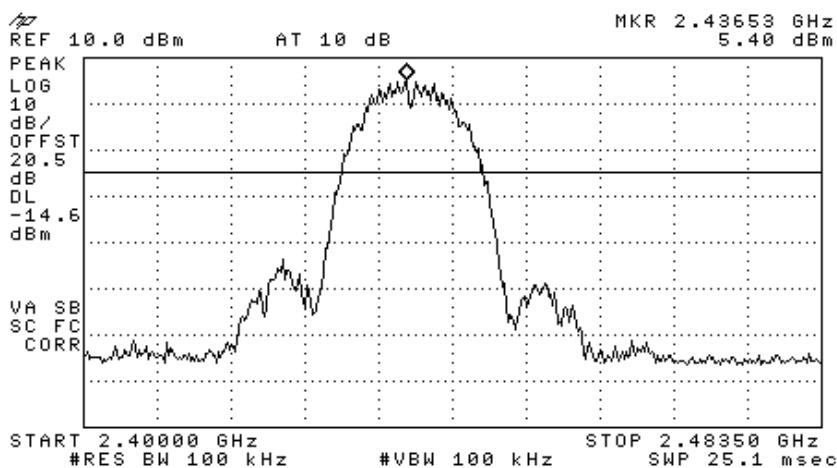

Figure 246 —2437 MHz CCK

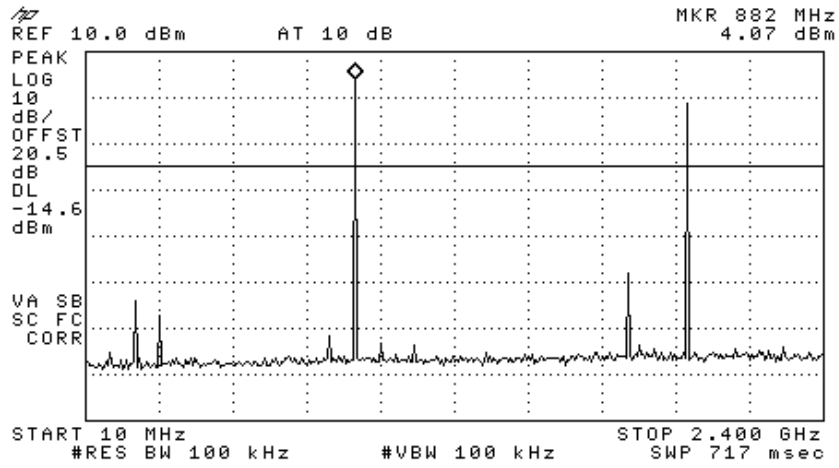

Figure 249 —2437 MHz CCK

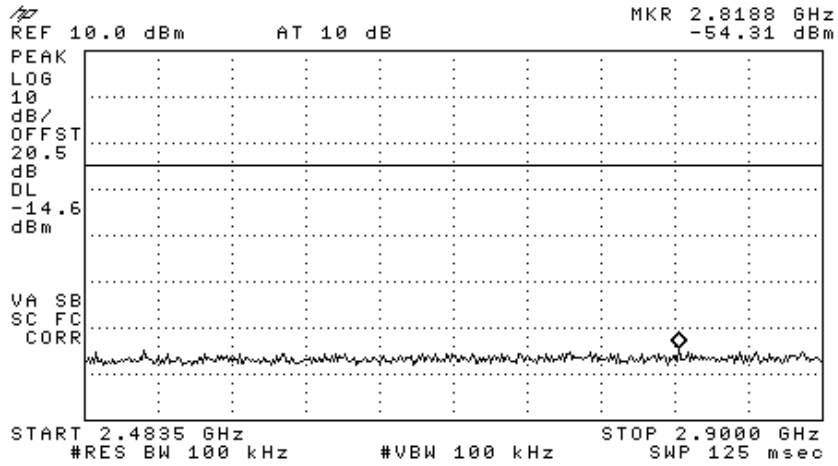

Figure 250 —2437 MHz CCK

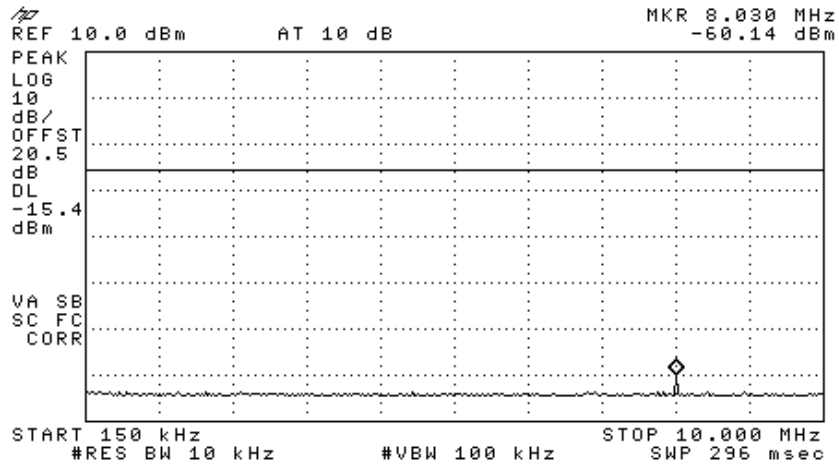

Figure 255 —2437 MHz 64QAM

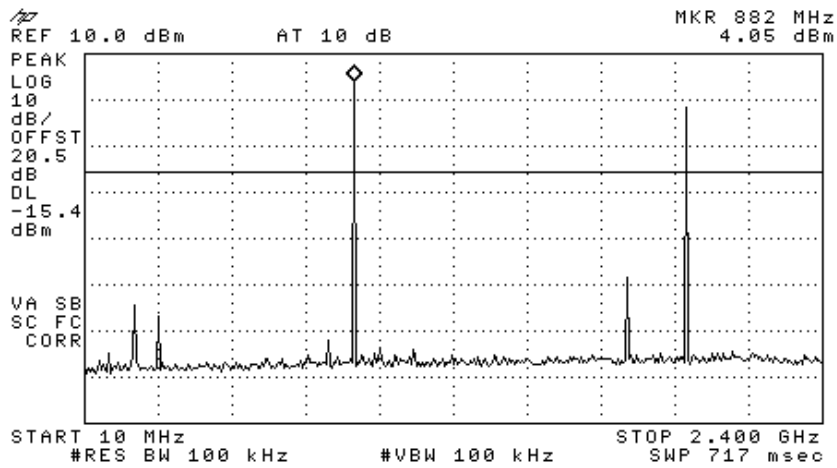

Figure 256 —2437 MHz 64QAM

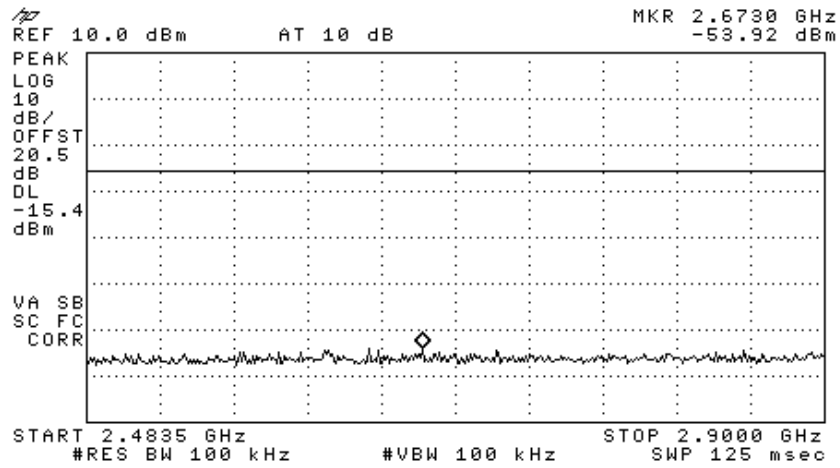

Figure 257 —2437 MHz 64QAM

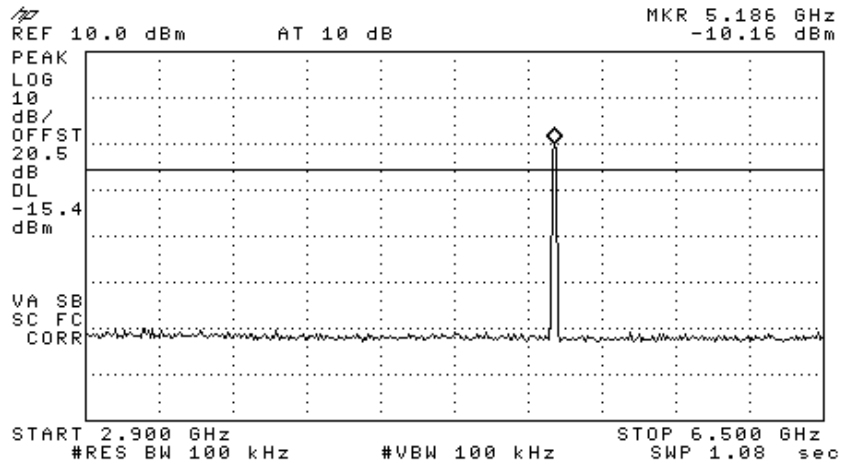

Figure 258 —2437 MHz 64QAM

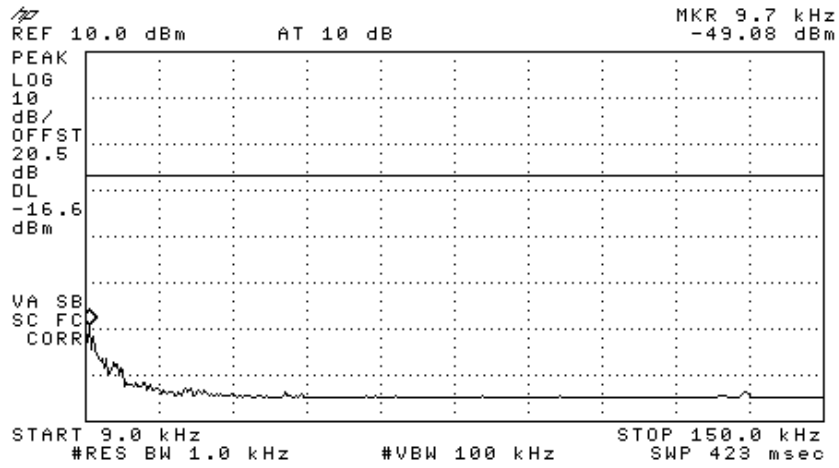

Figure 261 —2462 MHz DBPSK

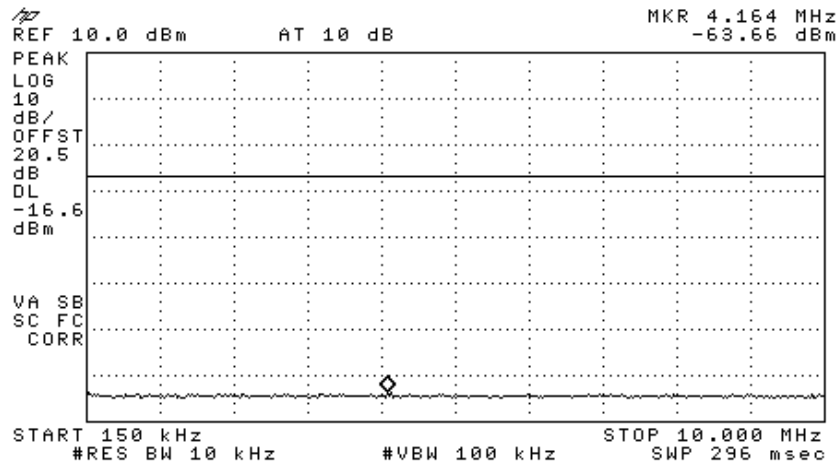

Figure 262 —2462 MHz DBPSK

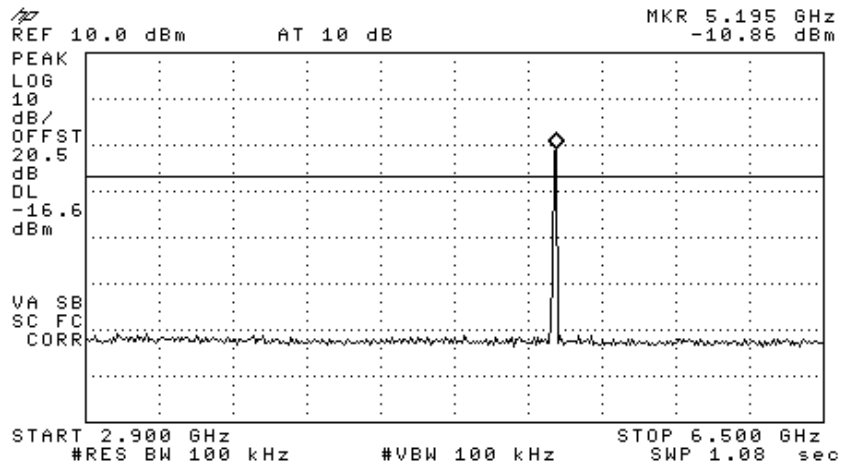

Figure 265 —2462 MHz DBPSK

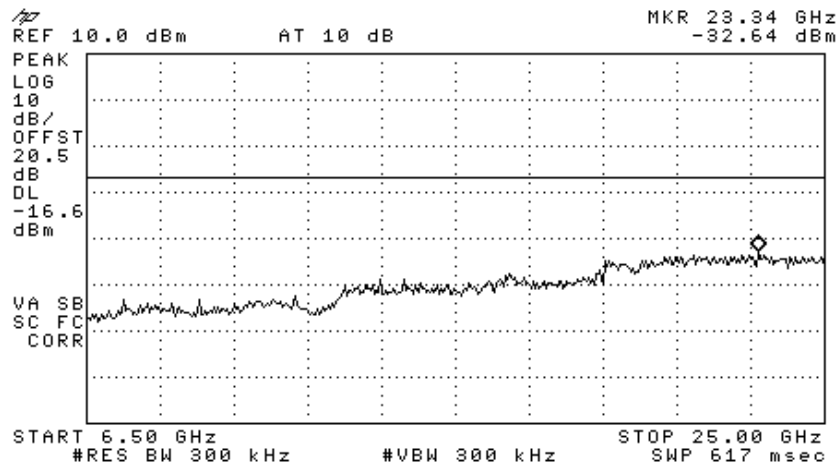

Figure 266 —2462 MHz DBPSK

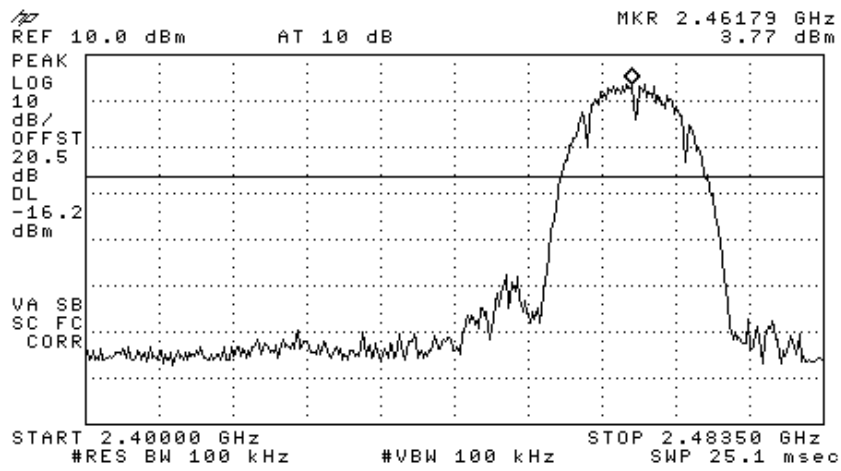

Figure 267 —2462 MHz BPSK

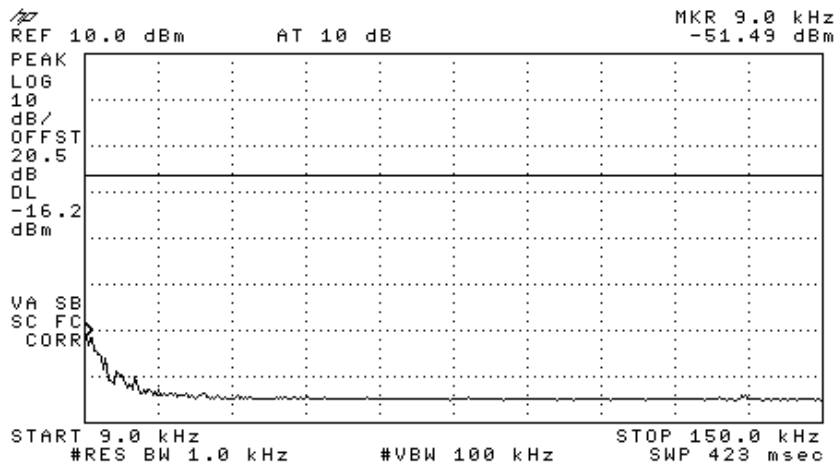

Figure 268 —2462 MHz BPSK

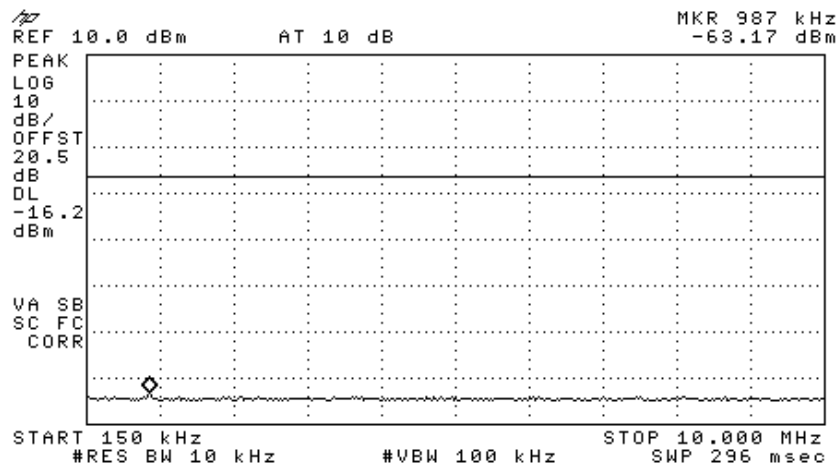

Figure 269 —2462 MHz BPSK

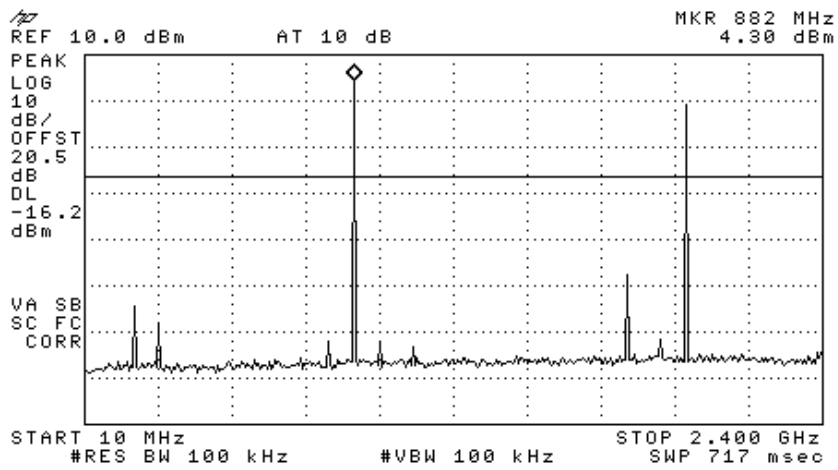

Figure 270 —2462 MHz BPSK

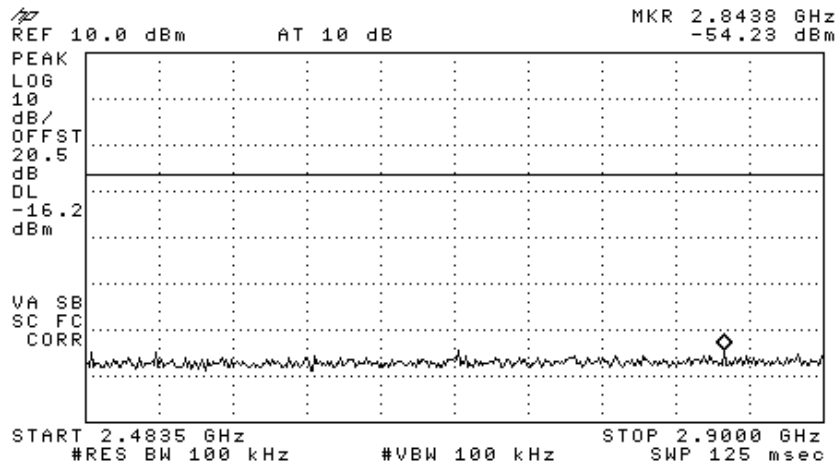

Figure 271 —2462 MHz BPSK

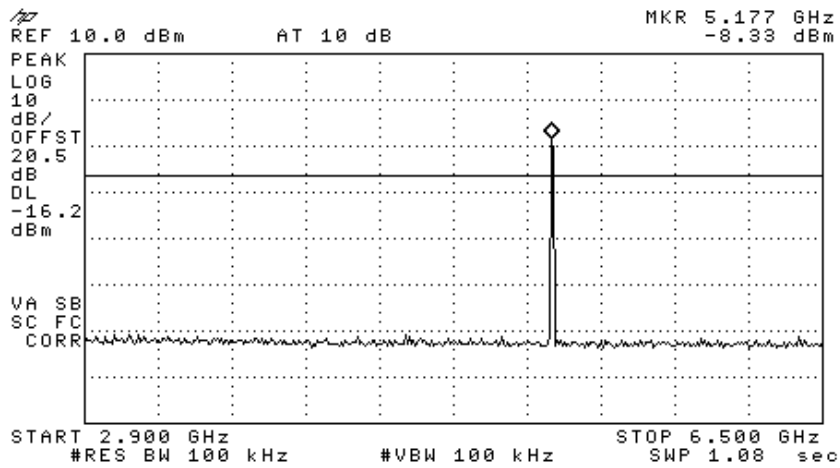

Figure 272 —2462 MHz BPSK

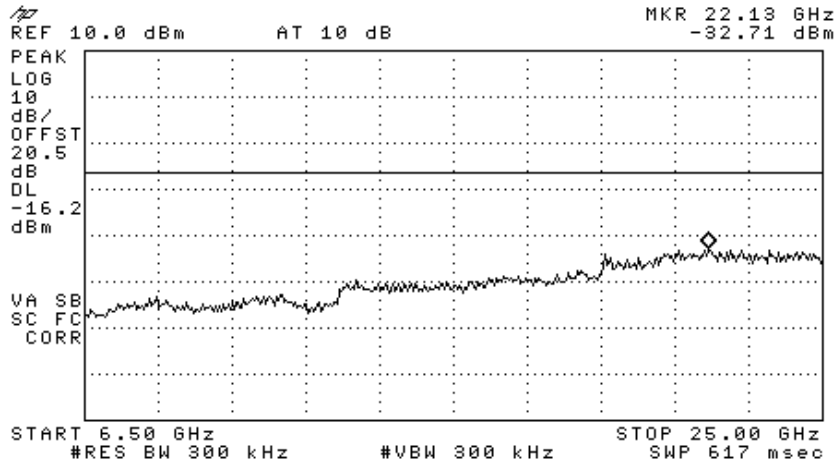

Figure 273 —2462 MHz BPSK

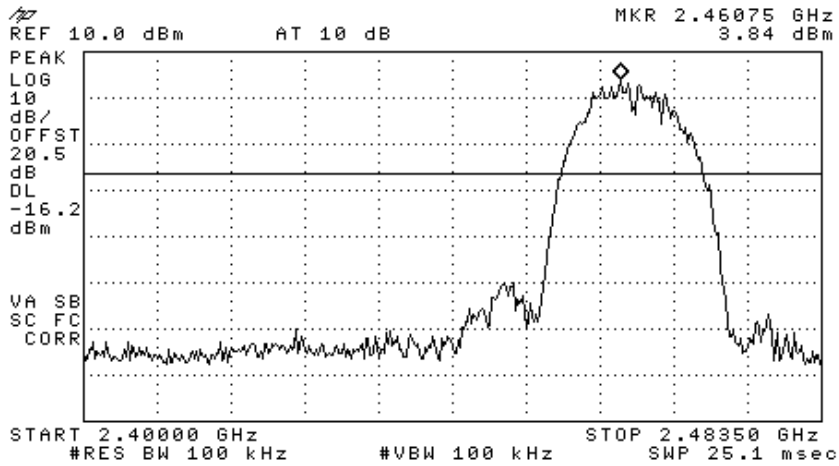

Figure 274 —2462 MHz CCK

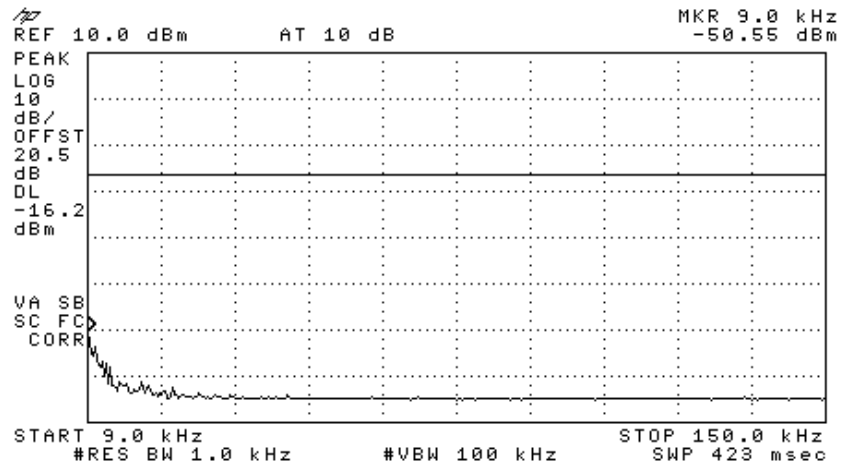

Figure 275 —2462 MHz CCK

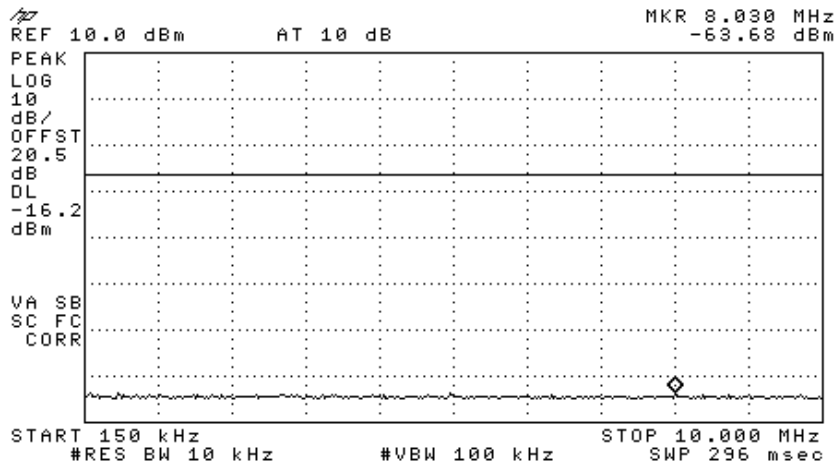

Figure 276 —2462 MHz CCK

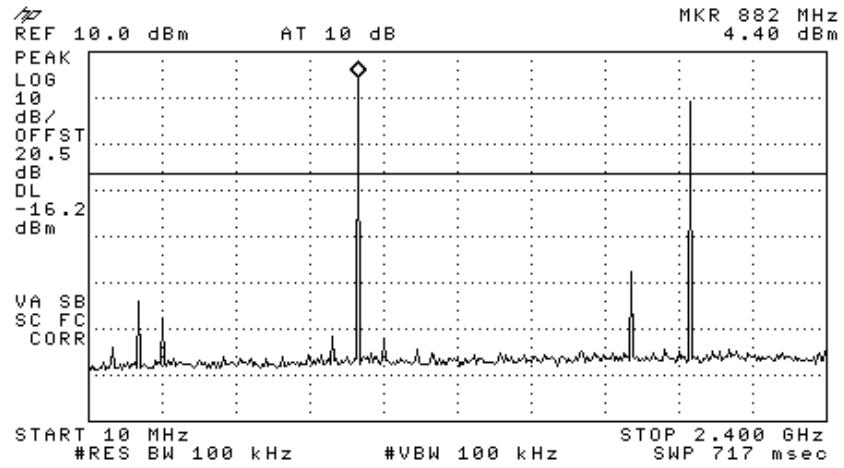

Figure 277 —2462 MHz CCK

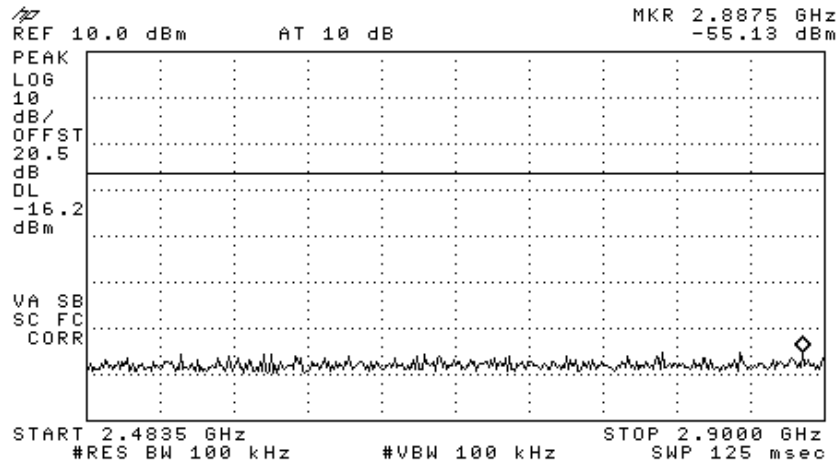

Figure 278 —2462 MHz CCK

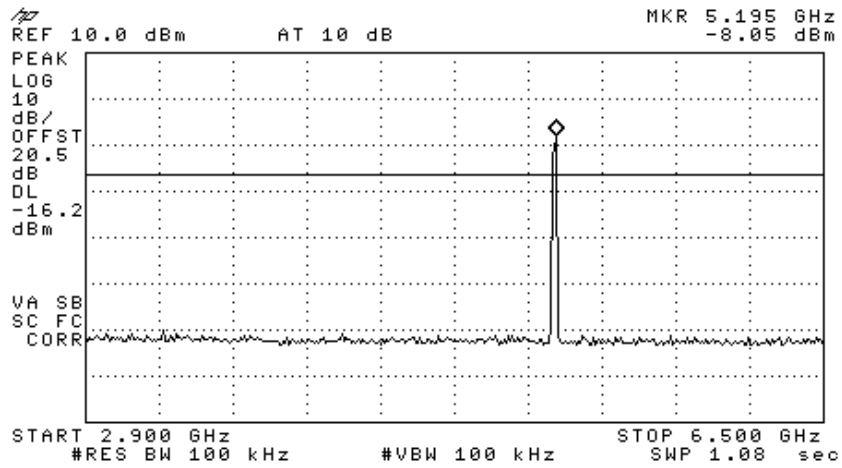

Figure 279 —2462 MHz CCK

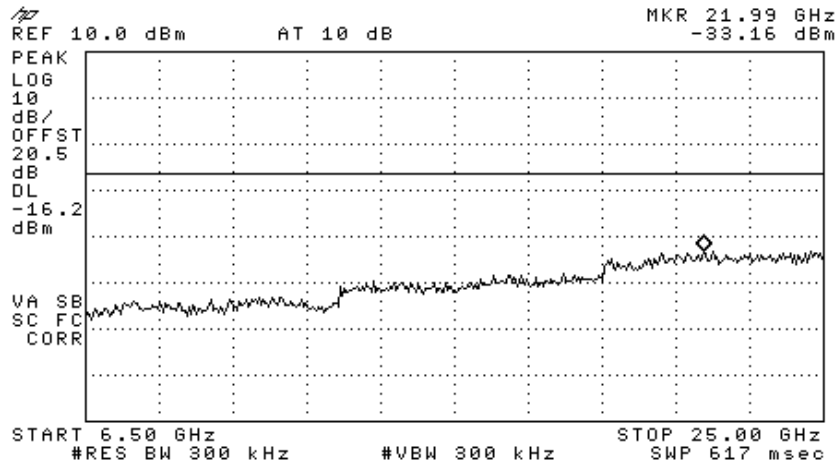

Figure 280 —2462 MHz CCK

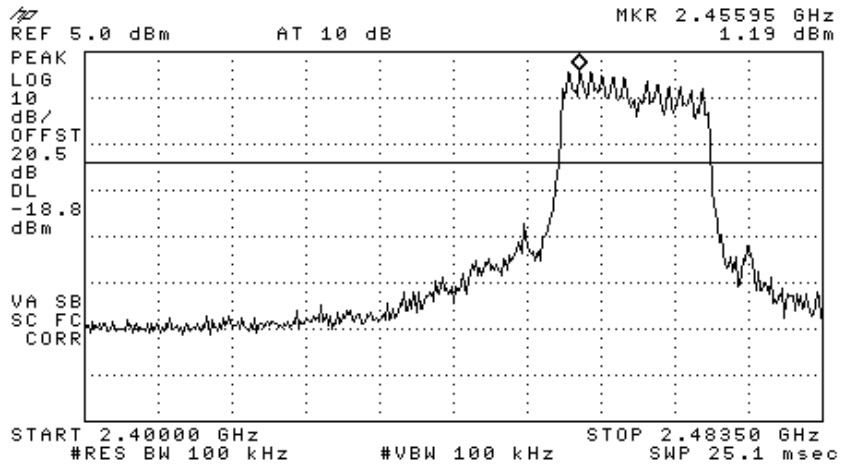

Figure 281 —2462 MHz 64QAM

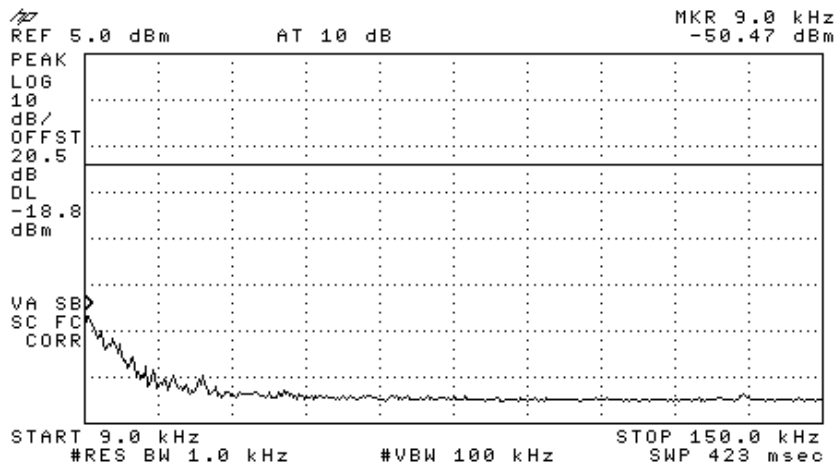

Figure 282 —2462 MHz 64QAM

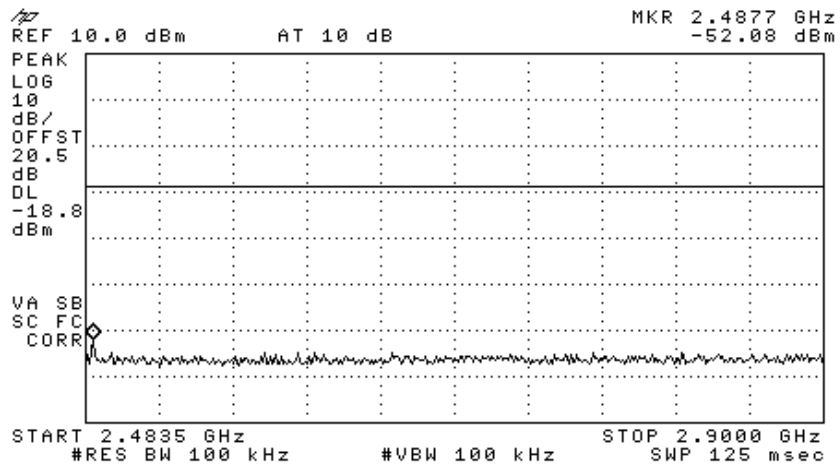

Figure 285 —2462 MHz 64QAM

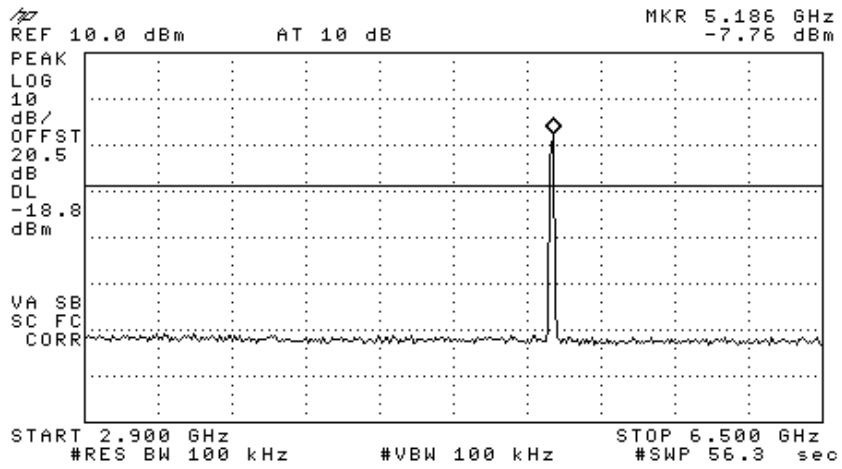

Figure 286 —2462 MHz 64QAM

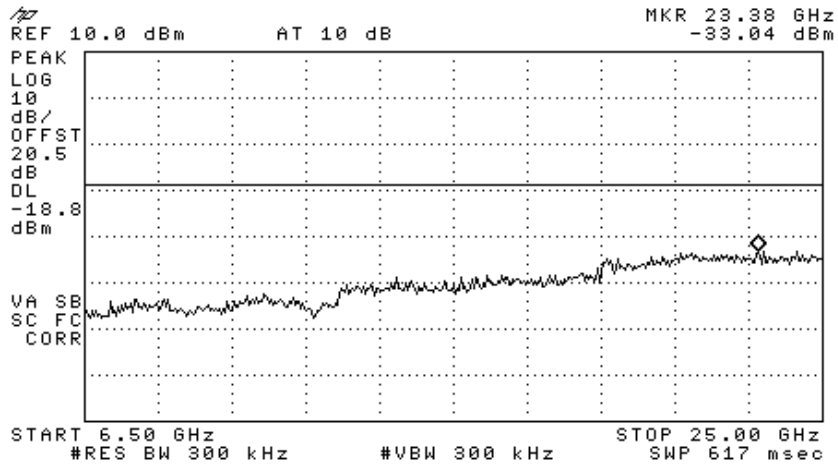

Figure 287 —2462 MHz 64QAM

19.2 Results table

E.U.T Description: WLAN Module With WCE (WiFi Coverage Extender) for DAS With Four Cisco 1242 Access Points

Model No.: 860M With WCE

Serial Number: 1. 860M: 73903D

2. WCE: 739038

Specification: F.C.C. Part 15, Subpart C (15.247)

Operation Frequency (MHz)	Modulation	Reading (dBc)	Specification (dBc)	Margin (dB)
2412	DBPSK	42.29	20.0	-22.29
	BPSK	32.92	20.0	-12.92
	CCK	33.83	20.0	-13.83
	64QAM	32.06	20.0	-12.06
2437	DBPSK	37.18	20.0	-17.18
	BPSK	38.65	20.0	-18.65
	CCK	38.04	20.0	-18.04
	64QAM	37.50	20.0	-17.50
2462	DBPSK	36.04	20.0	-16.04
	BPSK	36.51	20.0	-16.51
	CCK	36.96	20.0	-16.96
	64QAM	34.24	20.0	-14.24

Figure 288 Peak Power Output of 2400-2483.5 MHz Band

JUDGEMENT: Passed by 12.06 dB

TEST PERSONNEL:

Tester Signature: 

Date: 05.02.08

Typed/Printed Name: E. Pitt

19.3 Test Equipment Used.

Peak Power Output of 2400-2438.5 MHz Band

Instrument	Manufacturer	Model	Serial/Part Number	Calibration	
				Last Calibr.	Period
Spectrum Analyzer	HP	8592L	3826A01204	February 22, 2007	1 year
Attenuator	Jyebao	-	FAT-AM5AF5G6G2W20	May 9, 2007	1 year
Cable	Rhophase	KPS-5000-KPS	A1674	February 8, 2007	1 year

Figure 289 Test Equipment Used

20. 6 dB Minimum Bandwidth 2.4GHz Transmitter 802.11b/g + 802.11a + CELL + PCS Signals

20.1 Test procedure

The E.U.T. was set to the applicable test frequency. The E.U.T. antenna terminal was connected to the spectrum analyzer through an external attenuator (20 dB) and an appropriate coaxial cable (cable loss = 0.5 dB). The spectrum analyzer was set to 100 kHz resolution BW. The spectrum bandwidth of the E.U.T. at the point of 6 dB below maximum peak power was measured and recorded.

The E.U.T. was tested at 2412, 2437, and 2462 MHz with the following modulations: DBPSK (1Mbit/sec), BPSK (6Mbit/sec), CCK (11Mbit/sec) and 64QAM (54Mbit/sec).

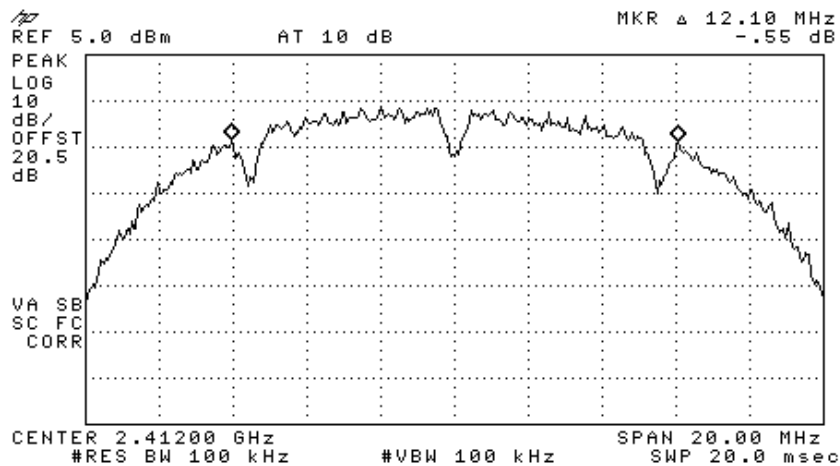

Figure 290 —2412 MHz DBPSK

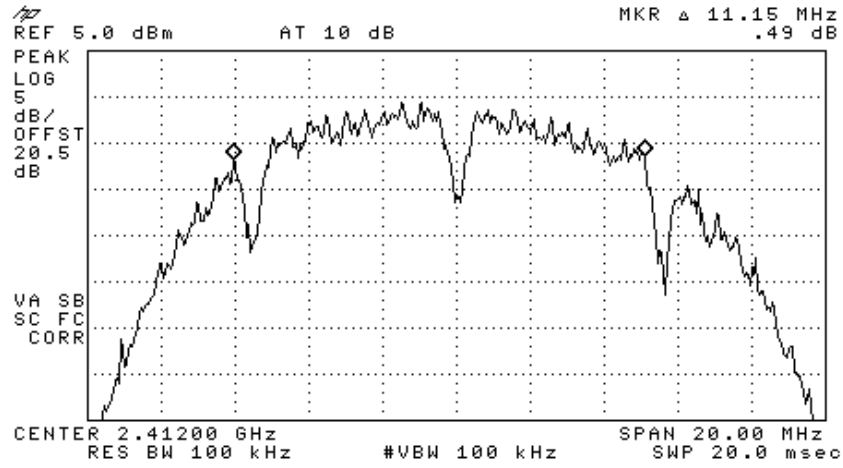

Figure 291 —2412 MHz BPSK

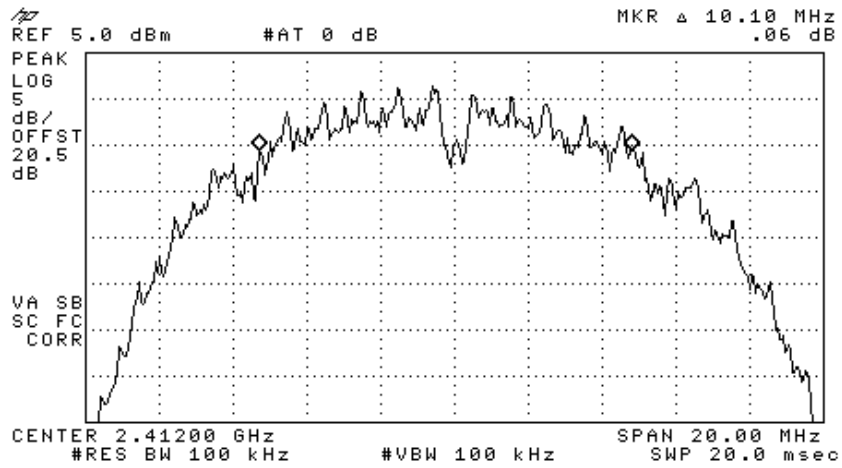

Figure 292 —2412 MHz CCK

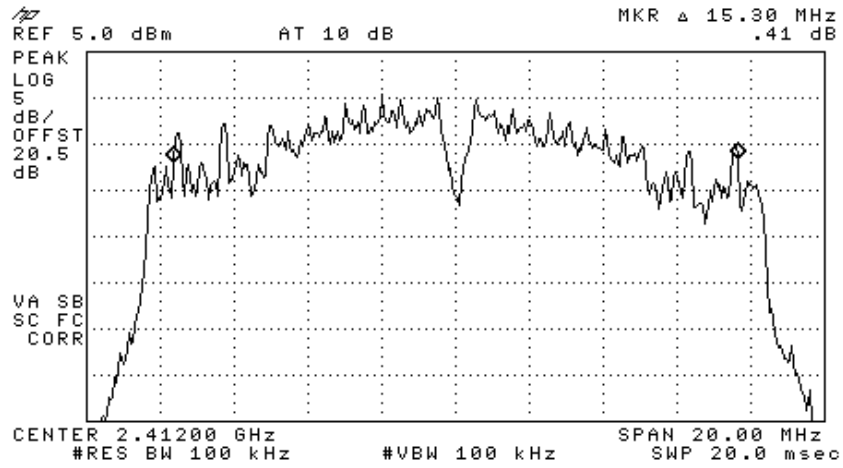

Figure 293 —2412 MHz 64QAM

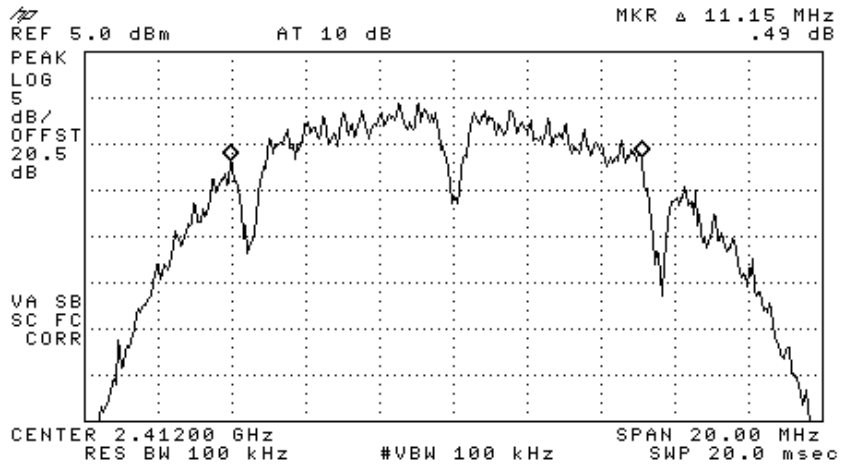

Figure 294 —2437 MHz DBPSK

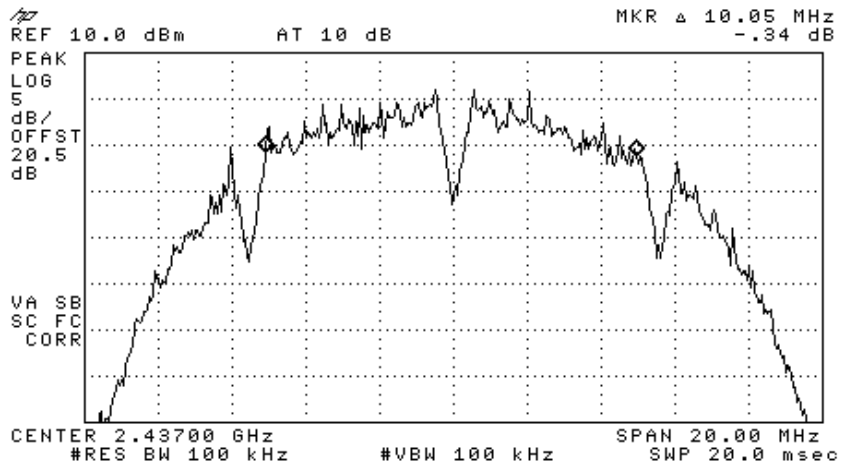

Figure 295 —2437 MHz BPSK

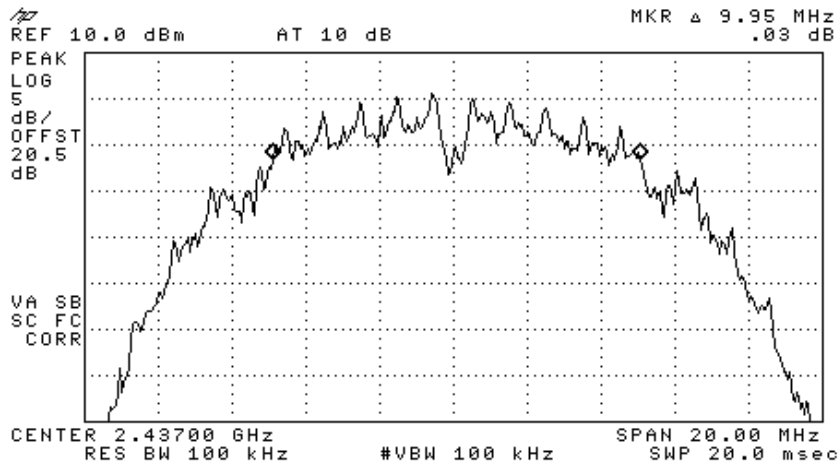

Figure 296 —2437 MHz CCK

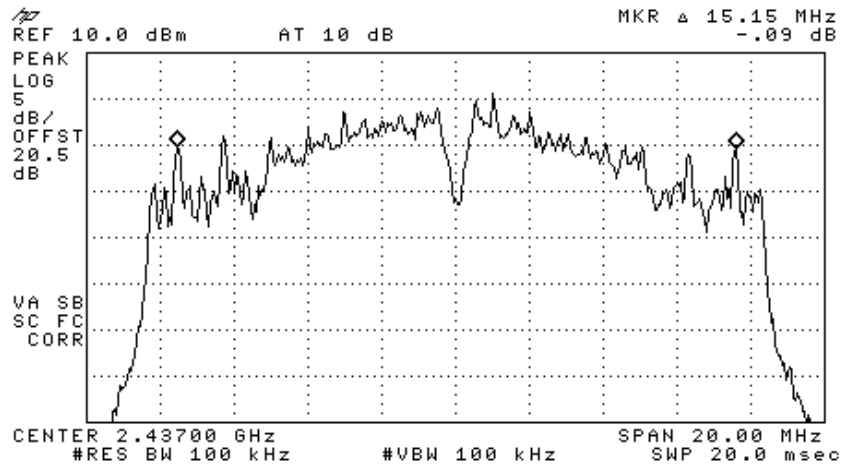

Figure 297 —2437 MHz 64QAM

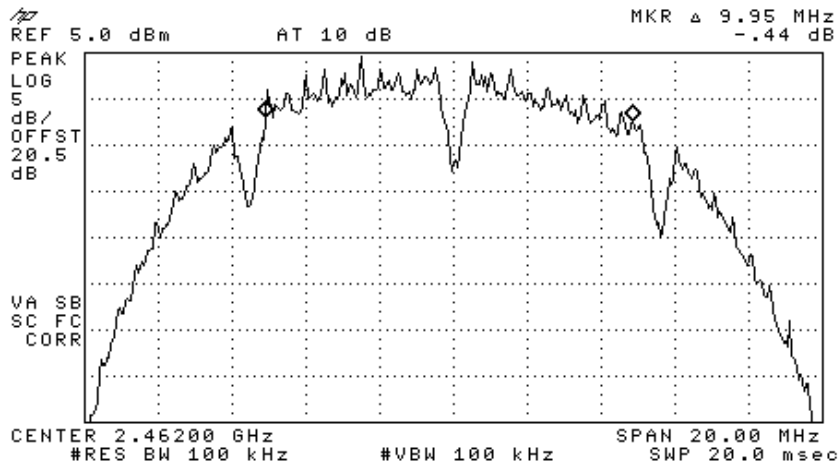

Figure 298 —2462 MHz DBPSK

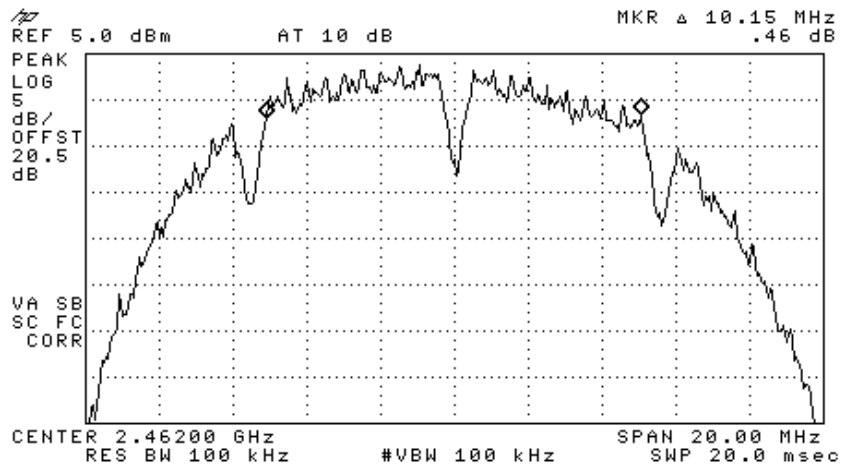

Figure 299 —2462 MHz BPSK

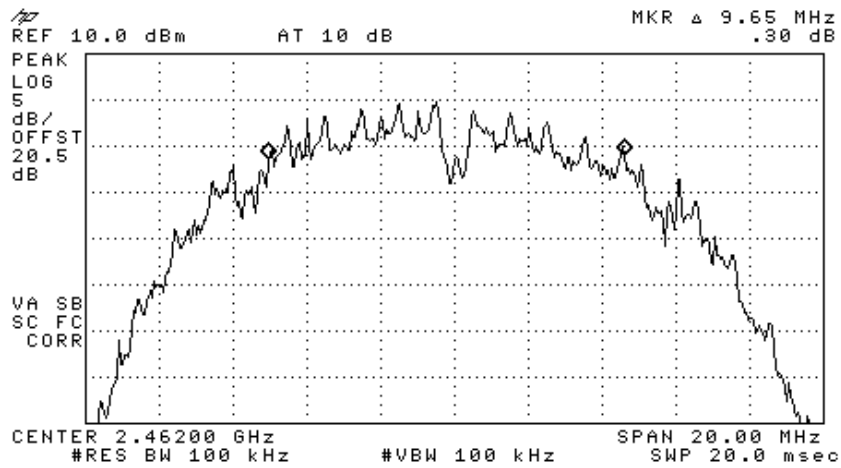

Figure 300 —2642 MHz CCK

20.3 Test Equipment Used.

6 dB Minimum Bandwidth

Instrument	Manufacturer	Model	Serial/Part Number	Calibration	
				Last Calibr.	Period
Spectrum Analyzer	HP	8592L	3826A01204	February 22, 2007	1 year
Attenuator	Jyebao	-	FAT-AM5AF5G6G2W20	May 9, 2007	1 year
Cable	Rhophase	KPS-5000-KPS	A1674	February 8, 2007	1 year

Figure 303 Test Equipment Used

21. Band Edge Spectrum 2.4GHz Transmitter 802.11b/g + 802.11a + CELL + PCS Signals

[In Accordance with section 15.247(c)]

21.1 Test procedure

The E.U.T. antenna terminal was connected to the spectrum analyzer through an external attenuator (20 dB) and an appropriate coaxial cable (cable loss = 0.5 dB). The spectrum analyzer was set to 100 kHz resolution BW. Maximum power level below 2400 MHz and above 2483.5 MHz was measured relative to power level at 2412 MHz, and 2462 MHz correspondingly.

The E.U.T. was tested using the following modulations: DBPSK (1Mbit/sec), BPSK (6Mbit/sec), CCK (11Mbit/sec) and 64QAM (54Mbit/sec).

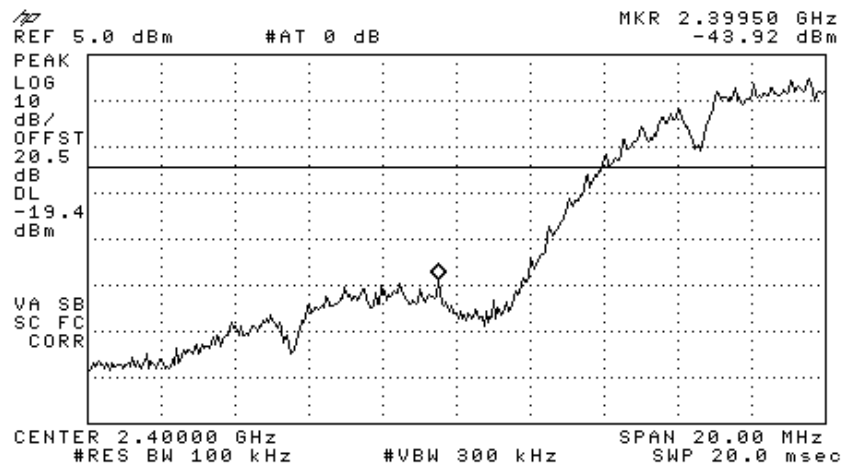

Figure 304 —2412 MHz DBPSK

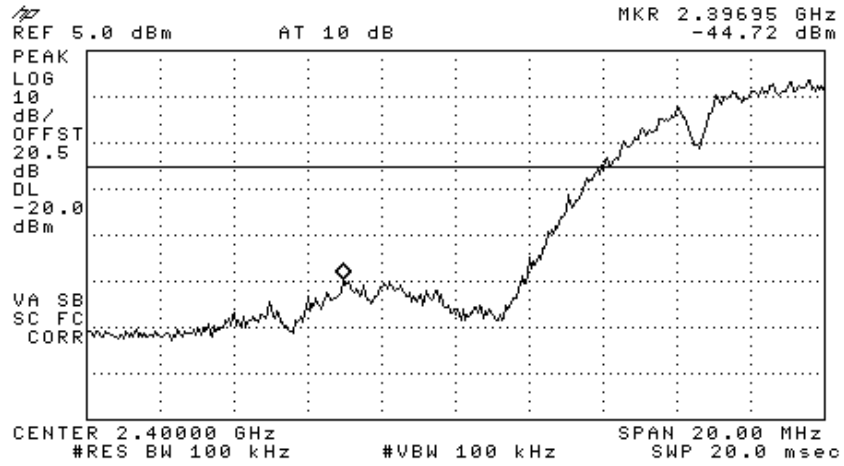

Figure 305 —2412 MHz BPSK

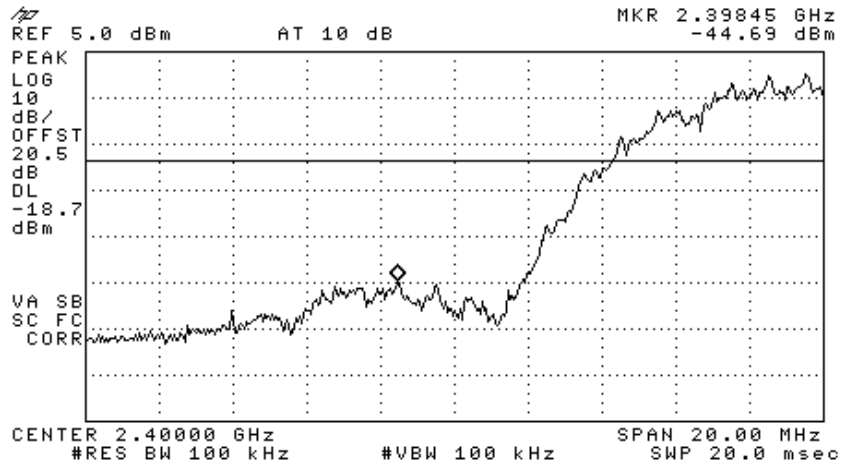

Figure 306 —2412 MHz CCK

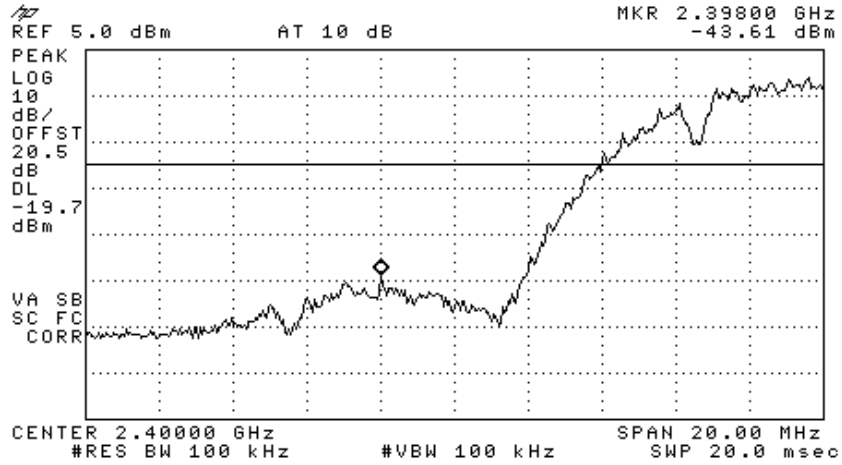

Figure 307 —2412 MHz 64QAM

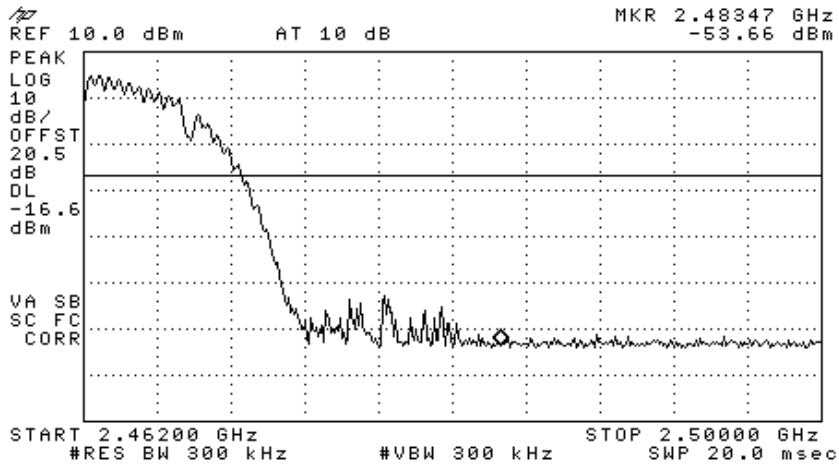

Figure 308 —2462 MHz DBPSK

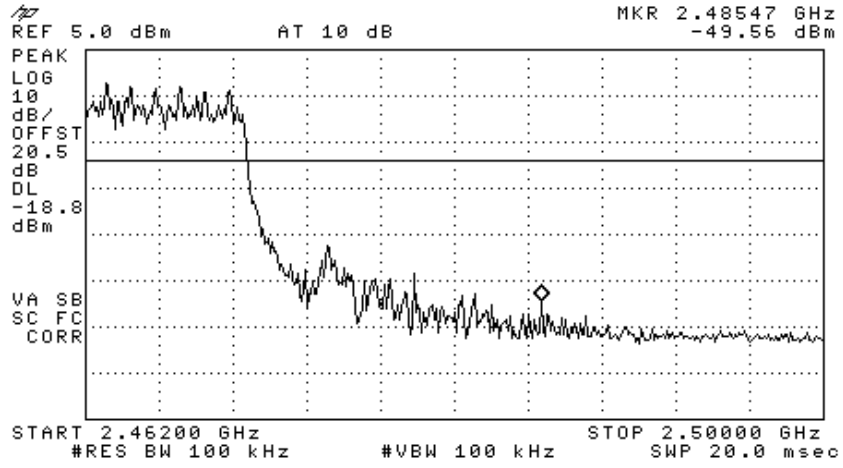

Figure 311 —2462 MHz 64QAM

21.2 Results table

E.U.T. Description: WLAN Module With WCE (WiFi Coverage Extender) for DAS
 With Four Cisco 1242 Access Points
 Model No.: 860M With WCE
 Serial Number: 1. 860M: 73903D
 2. WCE: 739038
 Specification: F.C.C. Part 15, Subpart C (15.247)

Operation Frequency (MHz)	Modulation	Band Edge Frequency (MHz)	Spectrum Level (dBc)	Specification (dBc)	Margin (dB)
2412	DBPSK	2.39950	43.92	20.0	-23.92
	BPSK	2.39695	44.72	20.0	-24.72
	CCK	2.39845	44.69	20.0	-24.69
	64QAM	2.39800	43.61	20.0	-23.61
2642	DBPSK	2.48347	53.66	20.0	-33.66
	BPSK	2.48347	56.36	20.0	-36.36
	CCK	2.48347	55.97	20.0	-35.97
	64QAM	2.48547	49.56	20.0	-29.56

Figure 312 Band Edge Spectrum

JUDGEMENT: Passed by 23.61 dB

TEST PERSONNEL:

Tester Signature: *E. Pitt*

Date: 05.02.08

Typed/Printed Name: E. Pitt

21.3 Test Equipment Used.

Band edge Spectrum

Instrument	Manufacturer	Model	Serial/Part Number	Calibration	
				Last Calibr.	Period
Spectrum Analyzer	HP	8592L	3826A01204	February 22, 2007	1 year
Attenuator	Jyebao	-	FAT-AM5AF5G6G2W20	May 9, 2007	1 year
Cable	Rhophase	KPS-5000-KPS	A1674	February 8, 2007	1 year

Figure 313 Test Equipment Used

22. Transmitted Power Density 2.4GHz Transmitter 802.11b/g + 802.11a + CELL + PCS Signals

[In accordance with section 15.247(d)]

22.1 Test procedure

The E.U.T. antenna terminal was connected to the spectrum analyzer through an external attenuator (20dB) and an appropriate coaxial cable (cable loss = 0.5dB). The spectrum analyzer was set to 3 kHz resolution BW. and sweep time of 1 second for each 3 kHz “window”. The spectrum peaks were located at each of the 3 operating frequencies.

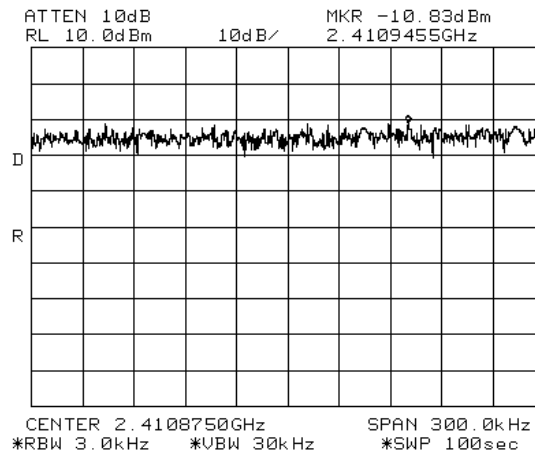

Figure 314 —2412 MHz DBPSK

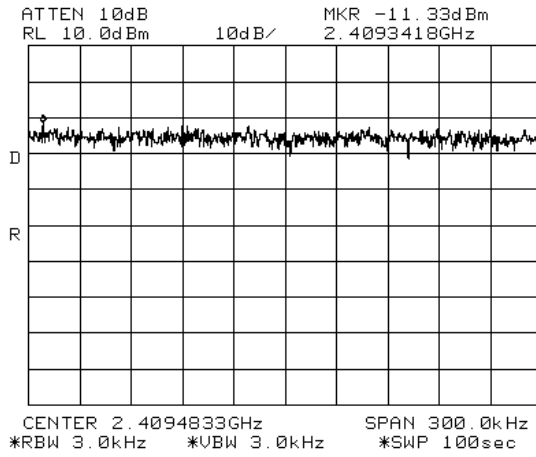

Figure 317 —2412 MHz 64QAM

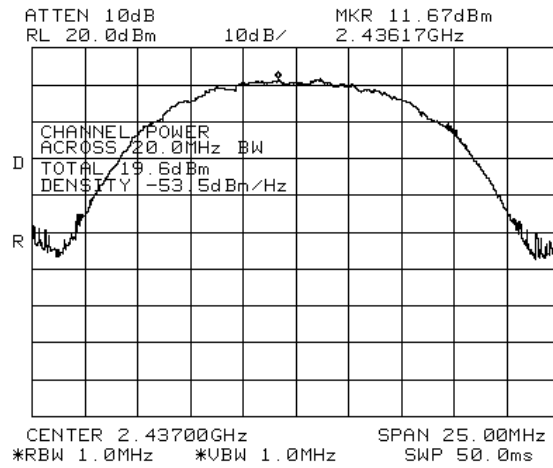

Figure 318 —2437 MHz DBPSK

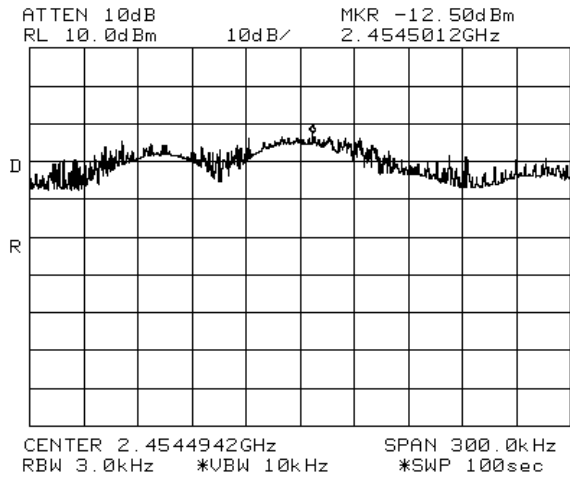

Figure 325 —2462 MHz 64QAM

22.3 Test Equipment Used.

Transmitted Power Density

Instrument	Manufacturer	Model	Serial/Part Number	Calibration	
				Last Calibr.	Period
Spectrum Analyzer	HP	8564E	3442A00275	November 14, 2007	1 year
Attenuator	Jyebao	-	FAT-AM5AF5G6G2W20	May 9, 2007	1 year
Cable	Rhophase	KPS-5000-KPS	A1674	February 8, 2007	1 year

Figure 327 Test Equipment Used

23. Antenna Gain 2.4GHz Transmitter 802.11b/g + 802.11a + CELL + PCS Signals

The antenna gain is 7 dBi.

24. R.F Exposure/Safety 2.4GHz Transmitter 802.11b/g + 802.11a + CELL + PCS Signals

Typical use of the E.U.T. is repeating WiFi signals for DAS. The typical placement of the E.U.T. is on a wall near the ceiling. The typical distance between the E.U.T. and the user in the worst case application, is >1 m.

Calculation of Maximum Permissible Exposure (MPE)

Based on Section 1.1307(b)(1) Requirements

(f) FCC limits at 2437 MHz is: $1 \frac{mW}{cm^2}$

Using table 1 of Section 1.1310 limit for general population/uncontrolled exposures, the above level is an average over 30 minutes.

(g) The power density produced by the E.U.T. is

$$S = \frac{P_t G_t}{4\pi R^2}$$

P_t - Transmitted Power 151.3 mw (Peak) = 21.8 dBm

G_T - Antenna Gain, 7 dBi = 5

R- Distance from Transmitter using 1 m worst case

(h) The peak power density is :

$$S_p = \frac{5 \times 151.3}{4\pi(100)^2} = 6.02 \times 10^{-3} \frac{mW}{cm^2}$$

(i) The duty cycle of transmission in actual worst case is 50%.

The average power source is:

$$75.6mW$$

(j) The averaged power density of the E.U.T. is:

$$S_{AV} = \frac{75.6 \times 5}{4\pi(100)^2} = 3.01 \times 10^{-3} \frac{mW}{cm^2}$$

(f) This is 3 orders of magnitude below the FCC limit.

25. Radiated Emission Per FCC Part 15 Sub-Part B Test Data 802.11b/g + 802.11a + CELL + PCS Signals

25.1 Test Specification

30-25000 MHz, FCC Part 15, Subpart B, CLASS B

25.2 Test Procedure

The E.U.T. operation mode and test set-up are as described in Section 4.

A preliminary measurement to characterize the E.U.T was performed inside the shielded room at a distance of 3 meters, using peak detection mode and broadband antennas. The preliminary measurements produced a list of the highest emissions. The E.U.T was then transferred to the open site, and placed on a remote-controlled turntable. The E.U.T was placed on a non-metallic table, 0.8 meters above the ground. The effect of varying the position of the cables was investigated to find the configuration that produces maximum emission.

The frequency range 30-25000 MHz was scanned, and the list of the highest emissions was verified and updated accordingly.

The emissions were measured using a computerized EMI receiver complying to CISPR 16 requirements. The specification limits and applicable correction factors are loaded to the receiver via a 3.5" floppy disk.

In the frequency range 2.9 - 25 GHz, a spectrum analyzer including a low noise amplifier was used. The test distance was 3 meters. During peak measurements, the I.F. bandwidth was 1 MHz, and video bandwidth 3 MHz. During average measurements, the I.F. bandwidth was 1 MHz and video bandwidth was 100 Hz.

The readings were maximized by adjusting the antenna height between 1-4 meters, the turntable azimuth between 0-360°, and the antenna polarization. Verification of the E.U.T emissions was based on the following methods: turning the E.U.T on and off; using a frequency span less than 10 MHz; observation of the signal level during turntable rotation. (Background noise is not affected by the rotation of the E.U.T.)

The emissions were measured at a distance of 3 meters.

The E.U.T. was tested in both Rx and Tx modes.

The E.U.T. was tested at the operating frequencies of 2412, 2437, and 2462 MHz using the following modulations: DBPSK, BPSK, CCK, and 64QAM.



25.3 **Test Data**

JUDGEMENT: Passed by 3.5 dB.

The margin between the emission level and the specification limit is 3.5 dB in the worst case at the frequency of 39.70 MHz, vertical polarization.

The EUT met the requirements of the F.C.C. Part 15, Subpart B, specification.

The results for all three operating frequencies and modulations were the same.

TEST PERSONNEL:

Tester Signature: _____

Date: 05.02.08

Typed/Printed Name: A. Sharabi

Radiated Emission

E.U.T Description WLAN Module With WCE (WiFi Coverage Extender) for DAS With Four Cisco 1242 Access Points
 Type 860M With WCE
 Serial Number: 1. 860M: 73903D
 2. WCE: 739038

Specification: FCC Part 15, Subpart B, Class B

Antenna Polarization: Horizontal Frequency range: 30 MHz to 300 MHz
 Antenna: 3 meters distance Detectors: Peak, Quasi-peak

Frequency	Peak Amp	QP Amp	Correction	Specification	Margin
(MHz)	(dB μ V/m)	(dB μ V/m)	(dB)	(dB μ V/m)	(dB)
39.70	31.7	27.3	13.4	40.0	-12.7
46.92	28.4	23.5	12.1	40.0	-16.5
162.58	36.0	31.7	15.4	43.5	-11.8
175.07	40.8	35.8	15.9	43.5	-7.7
207.20	37.1	32.2	18.0	43.5	-11.3
242.11	40.6	36.0	20.0	46.0	-10.0

**Figure 328. Radiated Emission. Antenna Polarization: HORIZONTAL.
 Detectors: Peak, Quasi-peak**

Note: Margin refers to the test results obtained minus specified requirement; thus a positive number indicates failure, and a negative result indicates that the product passes the test.

Radiated Emission

E.U.T Description WLAN Module With WCE (WiFi Coverage Extender) for DAS With Four Cisco 1242 Access Points
 Type 860M With WCE
 Serial Number: 1. 860M: 73903D
 2. WCE: 739038

Specification: FCC Part 15, Subpart B, Class B

Antenna Polarization: Horizontal
 Antenna: 3 meters distance

Frequency range: 30 MHz to 300 MHz
 Detectors: Peak, Quasi-peak

 13:48:32 FEB 04, 2008

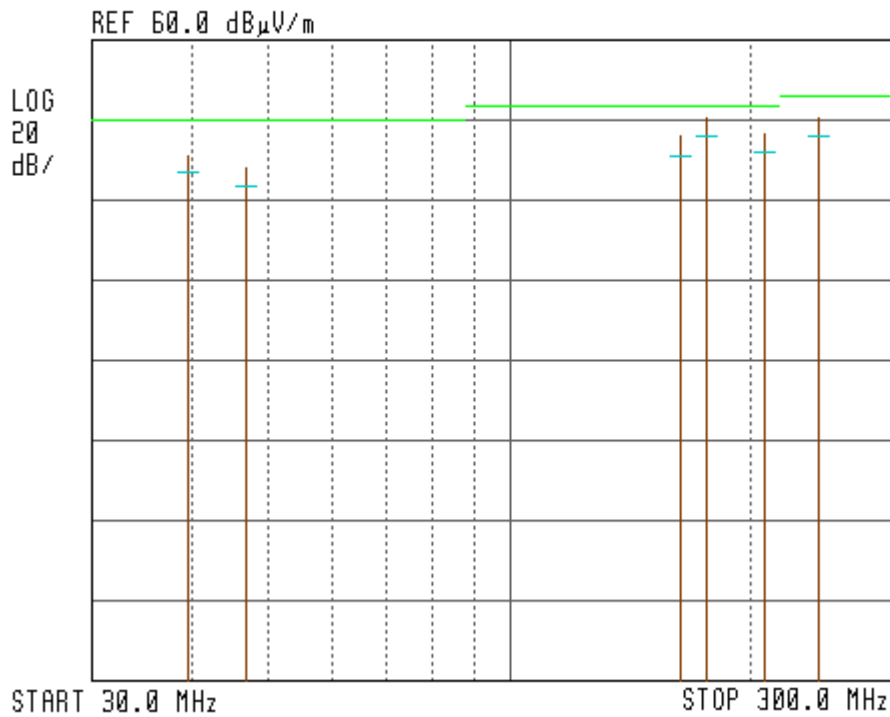

**Figure 329. Radiated Emission. Antenna Polarization: HORIZONTAL
 Detectors: Peak, Quasi-peak**

Note:

1. Horizontal axis shows logarithmic frequency scale.
2. The vertical axis shows amplitude (in dB μ V/m).
3. Peak detection is designated by the top of each vertical line.
4. Quasi-peak detection is designated by the first dash mark (from the top) of each vertical line.

Radiated Emission

E.U.T Description WLAN Module With WCE (WiFi Coverage Extender) for DAS With Four Cisco 1242 Access Points

Type 860M With WCE

Serial Number: 1. 860M: 73903D
 2. WCE: 739038

Specification: FCC Part 15, Subpart B, Class B

Antenna Polarization: Vertical
 Antenna: 3 meters distance

Frequency range: 30 MHz to 300 MHz
 Detectors: Peak, Quasi-peak

Frequency (MHz)	Peak Amp (dB μ V/m)	QP Amp (dB μ V/m)	Correction (dB)	Specification (dB μ V/m)	Margin (dB)
34.93	36.0	32.1	14.7	40.0	-7.9
39.70	41.6	36.5	13.4	40.0	-3.5
46.15	44.4	34.8	12.2	40.0	-5.2
162.58	41.6	38.8	15.4	43.5	-4.7
175.07	40.9	37.6	15.9	43.5	-5.9
242.11	38.6	34.7	20.0	46.0	-11.3

**Figure 330. Radiated Emission. Antenna Polarization: VERTICAL.
 Detectors: Peak, Quasi-peak**

Note: Margin refers to the test results obtained minus specified requirement; thus a positive number indicates failure, and a negative result indicates that the product passes the test.

Radiated Emission

E.U.T Description WLAN Module With WCE (WiFi Coverage Extender) for DAS With Four Cisco 1242 Access Points

Type 860M With WCE

Serial Number: 1. 860M: 73903D
 2. WCE: 739038

Specification: FCC Part 15, Subpart B, Class B

Antenna Polarization: Vertical
 Antenna: 3 meters distance

Frequency range: 30 MHz to 300 MHz
 Detectors: Peak, Quasi-peak

 12:34:02 FEB 04, 2008

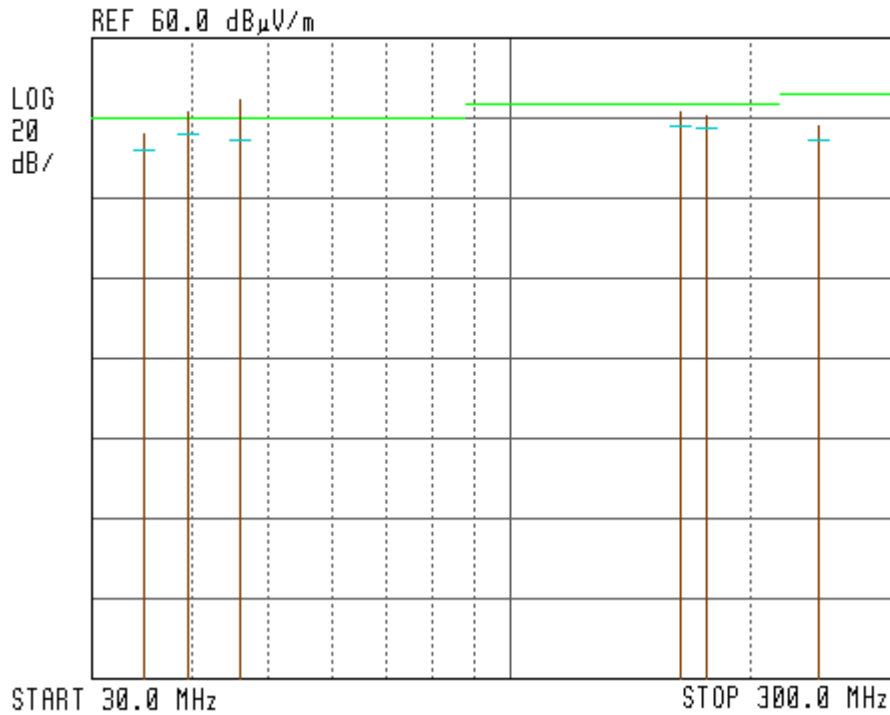

Figure 331. Radiated Emission. Antenna Polarization: VERTICAL. Detectors: Peak, Quasi-peak

Note:

1. Horizontal axis shows logarithmic frequency scale.
2. The vertical axis shows amplitude (in dB μ V/m).
3. Peak detection is designated by the top of each vertical line.
4. Quasi-peak detection is designated by the first dash mark (from the top) of each vertical line.

25.4 Test Instrumentation Used, Radiated Measurements

Instrument	Manufacturer	Model	Serial No.	Calibration	Period
EMI Receiver	HP	85422E	3906A00276	November 12, 2007	1 Year
RF Filter Section	HP	85420E	3705A00248	November 12, 2007	1 Year
Antenna Biconical	ARA	BCD 235/B	1041	March 22, 2007	1 Year
Antenna Log Periodic	ARA	LPD-2010/A	1038	November 22, 2007	1 Year
Antenna Log Periodic	A.H. Systems	SAS- 200/511	253	February 4, 2007	2 Years
Double Ridged Waveguide Horn Antenna	EMCO	3115	29845	March 15, 2006	2 Years
Horn Antenna	ARA	SWH-28	1008	December 8, 2006	2 Years
Horn Antenna	Narda	V637	0410	December 8, 2006	2 Years
Low Noise Amplifier	DBS MICROWAVE	LNA-DBS- 0411N313	013	November 2, 2007	1 Year
Low Noise Amplifier	Sophia Wireless	LNA 28-B	232	January 9, 2007	1 Year
Low Noise Amplifier	MK Milliwave	MKT6-3000 4000-30-13P	399	January 9, 2007	1 Year
Spectrum Analyzer	HP	8592L	3826A01204	February 22, 2007	1 Year
Spectrum Analyzer	HP	8564E	3442A00275	November 14, 2007	1 Year
Antenna Mast	ARA	AAM-4A	1001	N/A	N/A
Turntable	ARA	ART-1001/4	1001	N/A	N/A
Mast & Table Controller	ARA	ACU-2/5	1001	N/A	N/A
Printer	HP	LaserJet 2200	JPKG19982	N/A	N/A

25.5 *Field Strength Calculation*

The field strength is calculated directly by the EMI Receiver software, and a "Correction Factors" data disk, using the following equation:

$$FS = RA + AF + CF$$

FS:	Field Strength [dB μ v/m]
RA:	Receiver Amplitude [dB μ v]
AF:	Receiving Antenna Correction Factor [dB/m]
CF:	Cable Attenuation Factor [dB]

No external pre-amplifiers are used.

26. Intermodulation Tests

26.1 Test procedure

An access point having maximum RF output power was used for this test.

The E.U.T. antenna terminal was connected to the spectrum analyzer through an external attenuator (20 dB) and an appropriate coaxial cable (cable loss = 3.5 dB). The spectrum analyzer was set to 1 kHz resolution BW for the frequency range 9.0-150.0 kHz, 10kHz for the frequency range 10kHz-10.0MHz, 100kHz for the frequency range 10.0MHz-2.4385GHz, and 1MHz for the frequency range 2.4385-25.0GHz.

4 input signals were sent simultaneously to the E.U.T. as follows:

802.11b/g: in the frequency range 2400-2483 MHz, 2412MHz 64QAM

802.11a: in the frequency range 5150-5250 MHz, 5180MHz BPSK

CELL: in the frequency range 869-894 MHz, 890MHz FM dev. 100kHz

PCS: in the frequency range 1930-1990 MHz, 1985MHz CDMA

The frequency range of 9kHz – 40.0GHz was scanned for unwanted signals.

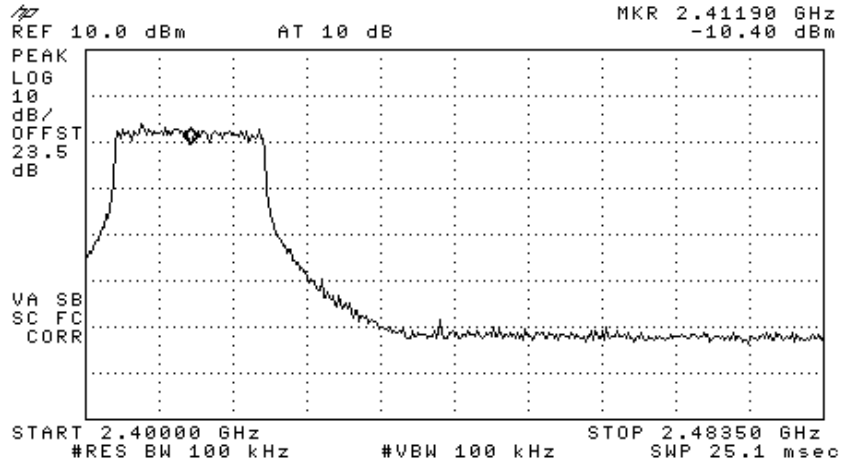

Figure 332 —2412MHz 64QAM

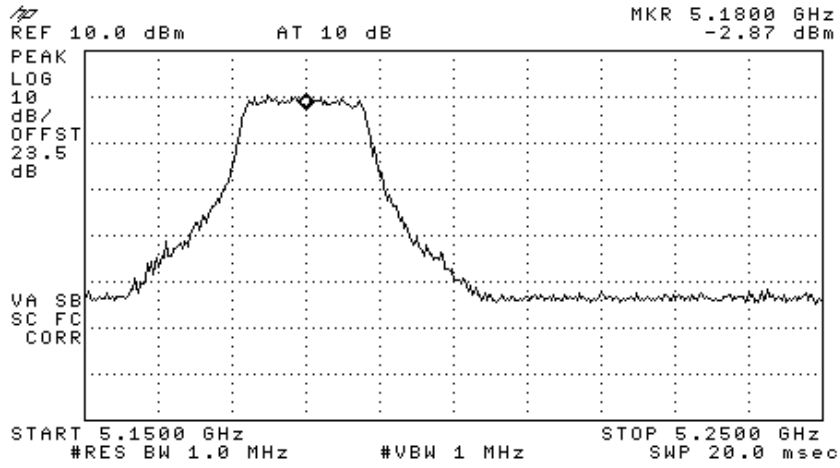

Figure 333 —5180MHz BPSK

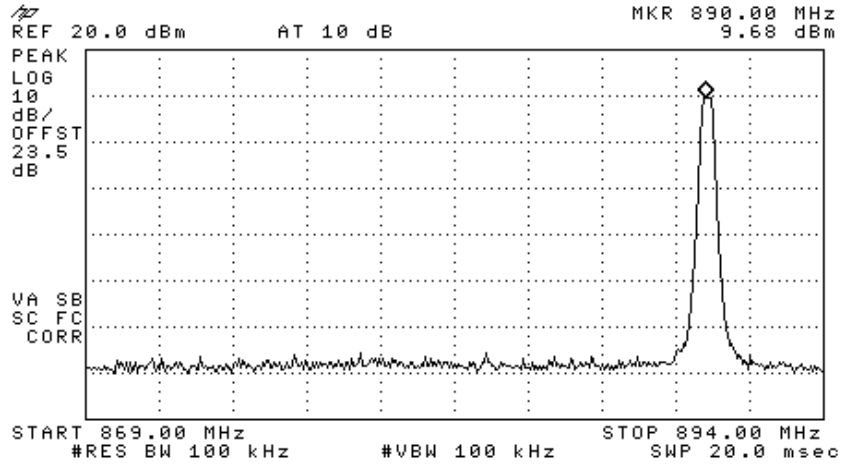

Figure 334 —890MHz FM

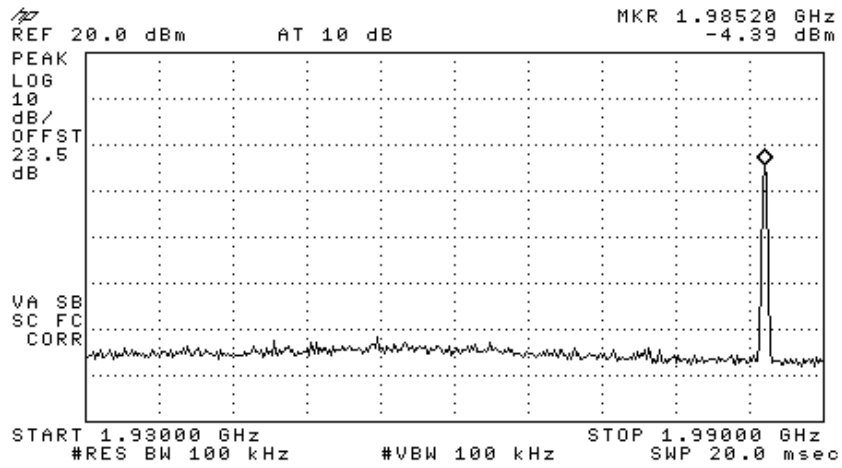

Figure 335 —1985MHz CDMA

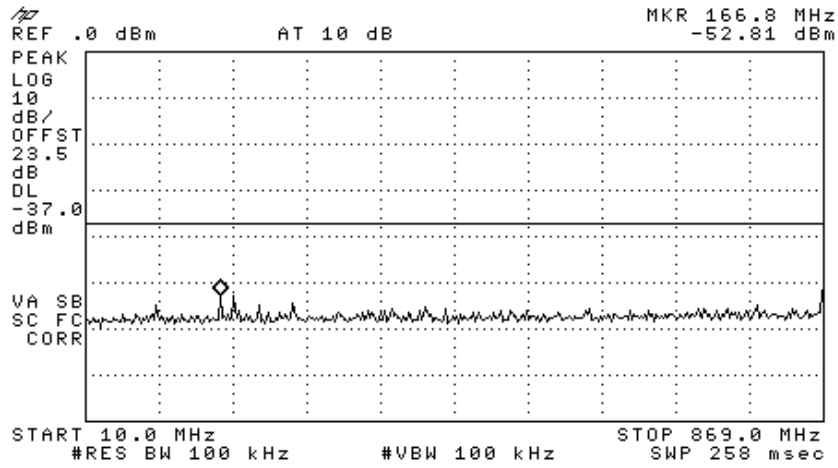

Figure 338

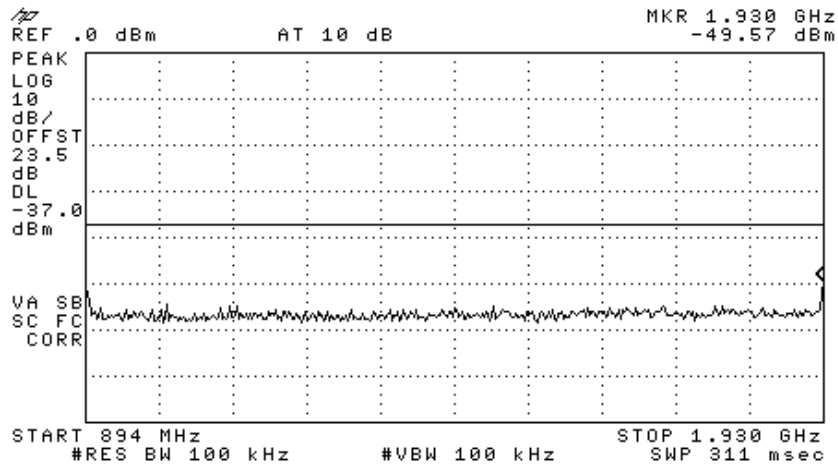

Figure 339

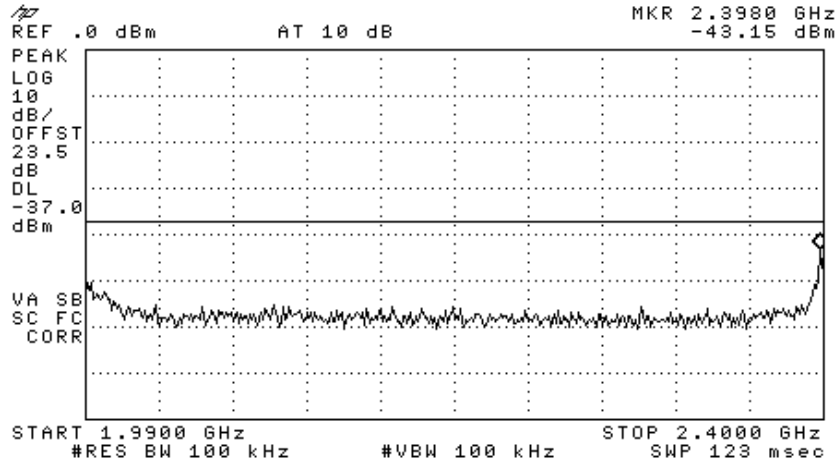

Figure 340

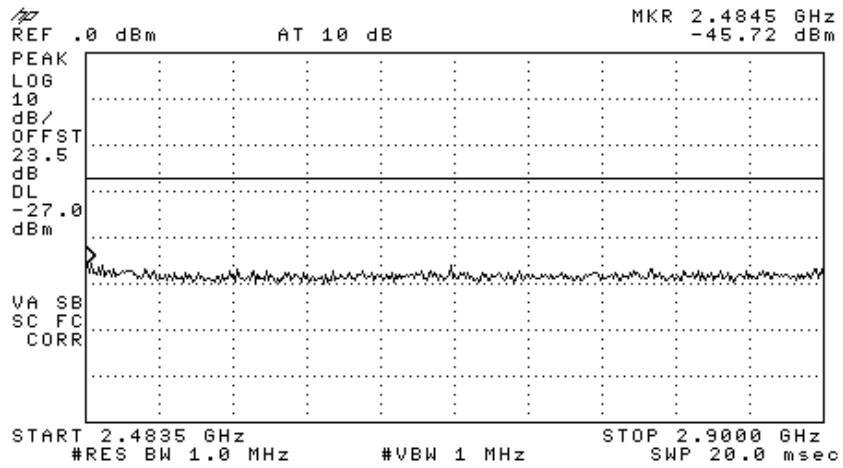

Figure 341

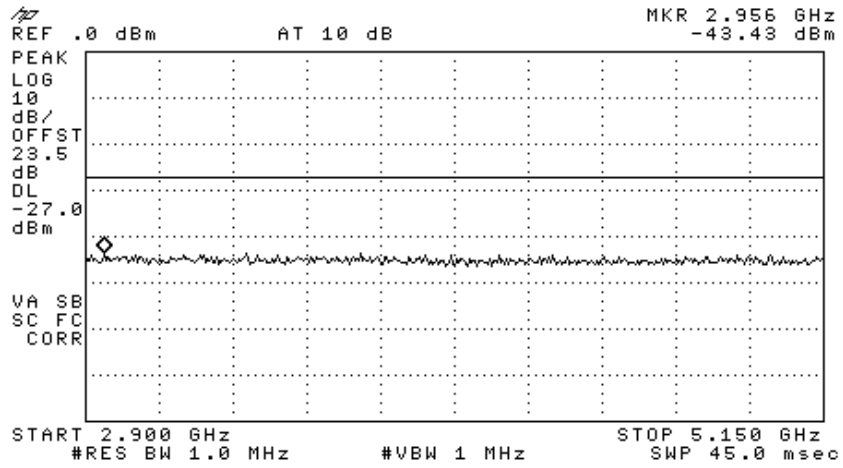

Figure 342

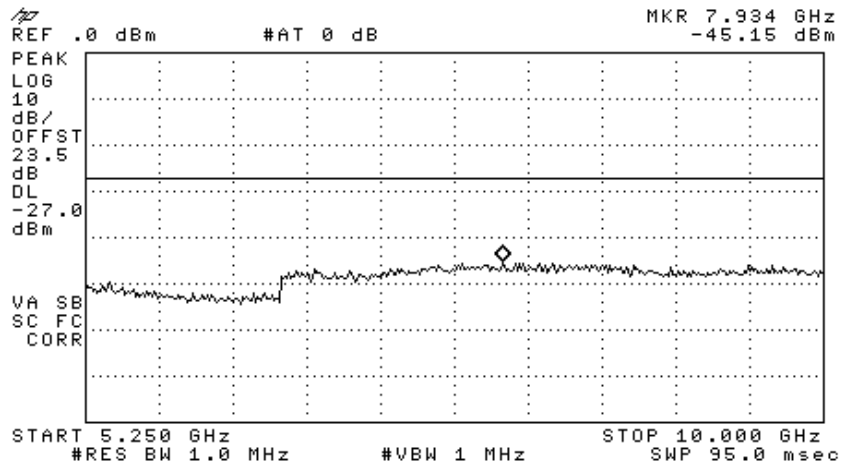

Figure 343

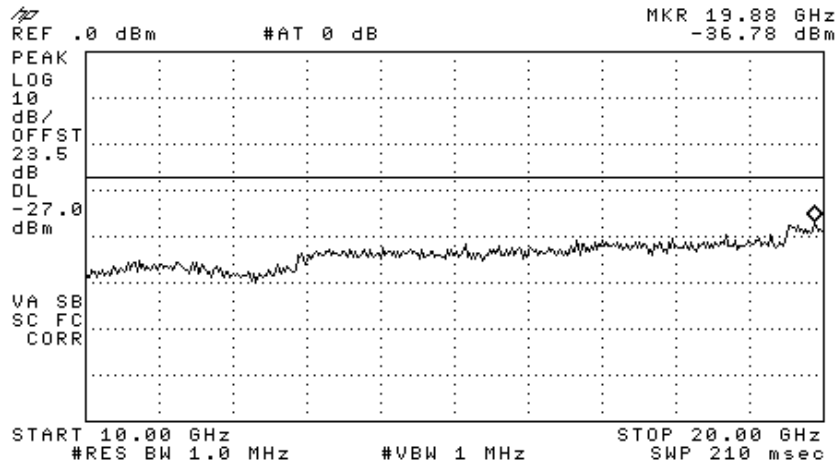

Figure 344

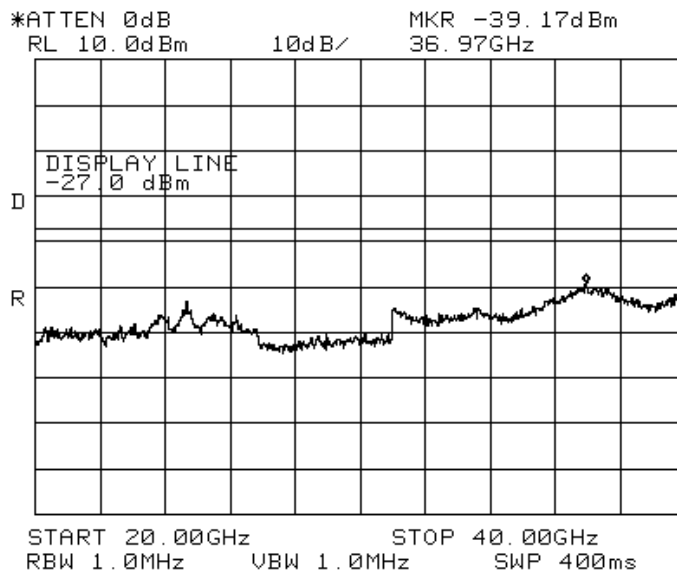

Figure 345



JUDGEMENT: Passed

TEST PERSONNEL:

Tester Signature: E. Pitt

Date: 05.02.08

Typed/Printed Name: E. Pitt

26.2 Test Equipment Used.

Intermodulation

Instrument	Manufacturer	Model	Serial/Part Number	Calibration	
				Last Calibr.	Period
Spectrum Analyzer	HP	8592L	3826A01204	February 22, 2007	1 year
Spectrum Analyzer	HP	8564E	3442A00275	November 26, 2006	1 year
Attenuator	Jyebao	-	FAT-AM5AF5G6G2W20	May 9, 2007	1 year
Cable	Rhophase	KPS-1501-1000	A1675	February 8, 2007	1 year

Figure 346 Test Equipment Used

27. APPENDIX A - CORRECTION FACTORS

27.1 Correction factors for CABLE
from EMI receiver
to test antenna
at 3 meter range.

FREQUENCY (MHz)	CORRECTION FACTOR (dB)	FREQUENCY (MHz)	CORRECTION FACTOR (dB)
10.0	0.3	1200.0	7.3
20.0	0.6	1400.0	7.8
30.0	0.8	1600.0	8.4
40.0	0.9	1800.0	9.1
50.0	1.1	2000.0	9.9
60.0	1.2	2300.0	11.2
70.0	1.3	2600.0	12.2
80.0	1.4	2900.0	13.0
90.0	1.6		
100.0	1.7		
150.0	2.0		
200.0	2.3		
250.0	2.7		
300.0	3.1		
350.0	3.4		
400.0	3.7		
450.0	4.0		
500.0	4.3		
600.0	4.7		
700.0	5.3		
800.0	5.9		
900.0	6.3		
1000.0	6.7		

NOTES:

1. The cable type is RG-214.
2. The overall length of the cable is 27 meters.
3. The above data is located in file 27MO3MO.CBL on the disk marked "Radiated Emission Tests EMI Receiver".

27.2 Correction factors for

CABLE

**from EMI receiver
to test antenna
at 3 meter range.**

FREQUENCY (GHz)	CORRECTION FACTOR (dB)
1.0	1.2
2.0	1.6
3.0	2.0
4.0	2.4
5.0	3.0
6.0	3.4
7.0	3.8
8.0	4.2
9.0	4.6
10.0	5.0
12.0	5.8

NOTES:

- 1. The cable type is RG-8.*
- 2. The overall length of the cable is 10 meters.*

27.3 Correction factors for CABLE
from spectrum analyzer
to test antenna above 2.9 GHz

FREQUENCY (GHz)	CORRECTION FACTOR (dB)	FREQUENCY (GHz)	CORRECTION FACTOR (dB)
1.0	1.9	14.0	9.1
2.0	2.7	15.0	9.5
3.0	3.5	16.0	9.9
4.0	4.2	17.0	10.2
5.0	4.9	18.0	10.4
6.0	5.5	19.0	10.7
7.0	6.0	20.0	10.9
8.0	6.5	21.0	11.2
9.0	7.0	22.0	11.6
10.0	7.5	23.0	11.9
11.0	7.9	24.0	12.3
12.0	8.3	25.0	12.6
13.0	8.7	26.0	13.0

NOTES:

1. The cable type is SUCOFLEX 104 E manufactured by SUHNER.
2. The cable is used for measurements above 2.9 GHz.
3. The overall length of the cable is 10 meters.

27.4 Correction factors for

CABLE

**from EMI receiver
to test antenna
at 10 meter range.**

FREQUENCY (MHz)	CORRECTION FACTOR (dB)	FREQUENCY (MHz)	CORRECTION FACTOR (dB)
10.0	0.3	1200.0	9.8
20.0	0.8	1400.0	10.0
30.0	0.9	1600.0	11.3
40.0	1.2	1800.0	12.2
50.0	1.4	2000.0	13.1
60.0	1.6	2300.0	14.5
70.0	1.8	2600.0	15.9
80.0	1.9	2900.0	16.4
90.0	2.0		
100.0	2.1		
150.0	2.6		
200.0	3.2		
250.0	3.8		
300.0	4.2		
350.0	4.6		
400.0	5.1		
450.0	5.3		
500.0	5.6		
600.0	6.3		
700.0	7.0		
800.0	7.6		
900.0	8.0		
1000.0	8.7		

NOTES:

1. The cable type is RG-214.
2. The overall length of the cable is 34 meters.
3. The above data is located in file 34M10MO.CBL on the disk marked "Radiated Emissions Tests EMI Receiver".

12.6 Correction factors for LOG PERIODIC ANTENNA

**Type LPD 2010/A
at 3 and 10 meter ranges.**

Distance of 3 meters

FREQUENCY (MHz)	AFE (dB/m)
200.0	9.1
250.0	10.2
300.0	12.5
400.0	15.4
500.0	16.1
600.0	19.2
700.0	19.4
800.0	19.9
900.0	21.2
1000.0	23.5

Distance of 10 meters

FREQUENCY (MHz)	AFE (dB/m)
200.0	9.0
250.0	10.1
300.0	11.8
400.0	15.3
500.0	15.6
600.0	18.7
700.0	19.1
800.0	20.2
900.0	21.1
1000.0	23.2

NOTES:

1. Antenna serial number is 1038.
2. The above lists are located in file number 38M30.ANT for a 3 meter range,
and file number 38M100.ANT for a 10 meter range.
3. The files mentioned above are located on the disk marked "Radiated Emission
Test EMI Receiver".

27.5 Correction factors for

LOG PERIODIC ANTENNA

**Type SAS-200/511
at 3 meter range.**

FREQUENCY (GHz)	ANTENNA FACTOR (dB)
1.0	24.9
1.5	27.8
2.0	29.9
2.5	31.2
3.0	32.8
3.5	33.6
4.0	34.3
4.5	35.2
5.0	36.2
5.5	36.7
6.0	37.2
6.5	38.1

FREQUENCY (GHz)	ANTENNA FACTOR (dB)
7.0	38.6
7.5	39.2
8.0	39.9
8.5	40.4
9.0	40.8
9.5	41.1
10.0	41.7
10.5	42.4
11.0	42.5
11.5	43.1
12.0	43.4
12.5	44.4
13.0	44.6

NOTES:

1. Antenna serial number is 253.
2. The above lists are located in file number SAS3M0.ANT for a 3 meter range.
3. The files mentioned above are located on the disk marked "Antenna Factors".

**27.6 Correction factors for BICONICAL ANTENNA
Type BCD-235/B,
at 3 meter range**

FREQUENCY (MHz)	AFE (dB/m)
20.0	19.4
30.0	14.8
40.0	11.9
50.0	10.2
60.0	9.1
70.0	8.5
80.0	8.9
90.0	9.6
100.0	10.3
110.0	11.0
120.0	11.5
130.0	11.7
140.0	12.1
150.0	12.6
160.0	12.8
170.0	13.0
180.0	13.5
190.0	14.0
200.0	14.8
210.0	15.3
220.0	15.8
230.0	16.2
240.0	16.6
250.0	17.6
260.0	18.2
270.0	18.4
280.0	18.7
290.0	19.2
300.0	19.9
310	20.7
320	21.9
330	23.4
340	25.1
350	27.0

NOTES:

1. Antenna serial number is 1041.
2. The above list is located in file 19BC10M1.ANT on the disk marked "Radiated Emissions Tests EMI Receiver".

**27.7 Correction factors for BICONICAL ANTENNA
Type BCD-235/B,
10 meter range**

FREQUENCY (MHz)	AFE (dB/m)
30.0	12.1
40.0	10.6
50.0	10.6
60.0	8.9
70.0	8.5
80.0	9.6
90.0	9.4
100.0	9.6
110.0	10.3
120.0	10.7
130.0	12.6
140.0	12.7
150.0	12.7
160.0	13.8
170.0	13.7
180.0	14.9
190.0	13.4
200.0	13.1
210.0	14.0
220.0	14.5
230.0	15.8
240.0	16.0
250.0	16.6
260.0	16.7
270.0	18.3
280.0	18.5
290.0	19.3
300.0	20.9

NOTES:

1. Antenna serial number is 1041.
2. The above list is located in file 41BC10M1.ANT on the disk marked "Radiated Emissions Tests EMI Receiver".

27.8 Correction factors for Double-Ridged Waveguide Horn

**Model: 3115, S/N 29845
at 3 meter range.**

FREQUENCY (GHz)	ANTENNA FACTOR (dB 1/m)	ANTENN A Gain (dBi)	FREQUENCY (GHz)	ANTENNA FACTOR (dB 1/m)	ANTENNA Gain (dBi)
1.0	24.8	5.4	10.0	38.8	11.4
1.5	26.1	7.6	10.5	38.9	11.8
2.0	28.6	7.7	11.0	39.0	12.1
2.5	29.8	8.4	11.5	39.6	11.8
3.0	31.4	8.4	12.0	39.8	12.0
3.5	32.4	8.7	12.5	39.6	12.5
4.0	33.7	8.6	13.0	40.0	12.5
4.5	33.4	9.9	13.5	39.8	13.0
5.0	34.5	9.7	14.0	40.2	13.0
5.5	35.1	9.9	14.5	40.6	12.9
6.0	35.4	10.4	15.0	41.3	12.4
6.5	35.6	10.8	15.5	39.5	14.6
7.0	36.2	10.9	16.0	38.8	15.5
7.5	37.3	10.4	16.5	40.0	14.6
8.0	37.7	10.6	17.0	41.4	13.4
8.5	38.3	10.5	17.5	44.8	10.3
9.0	38.5	10.8	18.0	47.2	8.1
9.5	38.7	11.1			

27.9 Correction factors for

**Horn Antenna
Model: SWH-28
at 1 meter range.**

FREQUENCY (GHz)	AFE (dB /m)	Gain (dB1)
18.0	40.3	16.1
19.0	40.3	16.3
20.0	40.3	16.1
21.0	40.3	16.3
22.0	40.4	16.8
23.0	40.5	16.4
24.0	40.5	16.6
25.0	40.5	16.7
26.0	40.6	16.4

27.10 Correction factors for

**Horn Antenna
Model: V637**

FREQUENCY (GHz)	AFE (dB /m)	Gain (dB1)
26.0	43.6	14.9
27.0	43.7	15.1
28.0	43.8	15.3
29.0	43.9	15.5
30.0	43.9	15.8
31.0	44.0	16.0
32.0	44.1	16.2
33.0	44.1	16.4
34.0	44.1	16.7
35.0	44.2	16.9
36.0	44.2	17.1
37.0	44.2	17.4
38.0	44.2	17.6
39.0	44.2	17.8
40.0	44.2	18.0

27.11 Correction factors for ACTIVE LOOP ANTENNA

Model 6502

S/N 9506-2950

FREQUENCY (MHz)	Magnetic Antenna Factor (dB)	Electric Antenna Factor (dB)
.009	-35.1	16.4
.010	-35.7	15.8
.020	-38.5	13.0
.050	-39.6	11.9
.075	-39.8	11.8
.100	-40.0	11.6
.150	-40.0	11.5
.250	-40.0	11.6
.500	-40.0	11.5
.750	-40.1	11.5
1.000	-39.9	11.7
2.000	-39.5	12.0
3.000	-39.4	12.1
4.000	-39.7	11.9
5.000	-39.7	11.8
10.000	40.2	11.3
15.000	-40.7	10.8
20.000	-40.5	11.0
25.000	-41.3	10.2
30.000	42.3	9.2