

Test specification:	Section 15.247(c), Radiated spurious emissions		
Test procedure:	FR Vol. 62, page 26243, Section 15.247(c) / ANSI C63.4, Section 13.1.4		
Test mode:	Compliance	Verdict:	PASS
Date & Time:	6/6/2006 1:35:17 PM		
Temperature: 23 °C	Air Pressure: 1013 hPa	Relative Humidity: 48 %	Power Supply: 120 VAC
Remarks:			

7.5 Field strength of spurious emissions

7.5.1 General

This test was performed to measure field strength of spurious emissions from the EUT. Specification test limits are given in Table 7.5.1.

Table 7.5.1 Radiated spurious emissions limits

Frequency, MHz	Field strength at 3 m within restricted bands, dB(μV/m)*		
	Peak	Quasi Peak	Average
0.009 – 0.090	148.5 – 128.5	NA	128.5 – 108.5**
0.090 – 0.110	NA	108.5 – 106.8**	NA
0.110 – 0.490	126.8 – 113.8	NA	106.8 – 93.8**
0.490 – 1.705	NA	73.8 – 63.0**	NA
1.705 – 30.0*		69.5	
30 – 88		40.0	
88 – 216		43.5	
216 – 960		46.0	
960 - 1000		54.0	
1000 – 10 th harmonic		74.0	

*- The limit for 3 m test distance was calculated using the inverse square distance extrapolation factor as follows:

$$\text{Lim}_{S_2} = \text{Lim}_{S_1} + 40 \log(S_1/S_2),$$

where S_1 and S_2 – standard defined and test distance respectively in meters.

** - The limit decreases linearly with the logarithm of frequency.

*** - The field strength limits applied from the lowest radio frequency generated in the device, without going below 9 kHz up to the tenth harmonic of the highest fundamental frequency.

7.5.2 Test procedure for spurious emission field strength measurements in 9 kHz to 30 MHz band

7.5.2.1 The EUT was set up as shown in Figure 7.5.1, energized and the performance check was conducted.

7.5.2.2 The specified frequency range was investigated with antenna connected to spectrum analyzer/ EMI receiver. To find maximum radiation the turntable was rotated 360° and the measuring antenna was rotated around its vertical axis.

7.5.2.3 The worst test results (the lowest margins) were recorded and shown in the associated plots.

7.5.3 Test procedure for spurious emission field strength measurements above 30 MHz

7.5.3.1 The EUT was set up as shown in Figure 7.5.2, energized and the performance check was conducted.

7.5.3.2 The specified frequency range was investigated with antenna connected to spectrum analyzer/ EMI receiver. To find maximum radiation the turntable was rotated 360°, the measuring antenna height was changed from 1 to 4 m, its polarization was switched from vertical to horizontal.

7.5.3.3 The worst test results (the lowest margins) were recorded and shown in the associated plots.

Test specification:	Section 15.247(c), Radiated spurious emissions		
Test procedure:	FR Vol. 62, page 26243, Section 15.247(c) / ANSI C63.4, Section 13.1.4		
Test mode:	Compliance	Verdict:	PASS
Date & Time:	6/6/2006 1:35:17 PM		
Temperature: 23 °C	Air Pressure: 1013 hPa	Relative Humidity: 48 %	Power Supply: 120 VAC
Remarks:			

Figure 7.5.1 Setup for spurious emission field strength measurements below 30 MHz

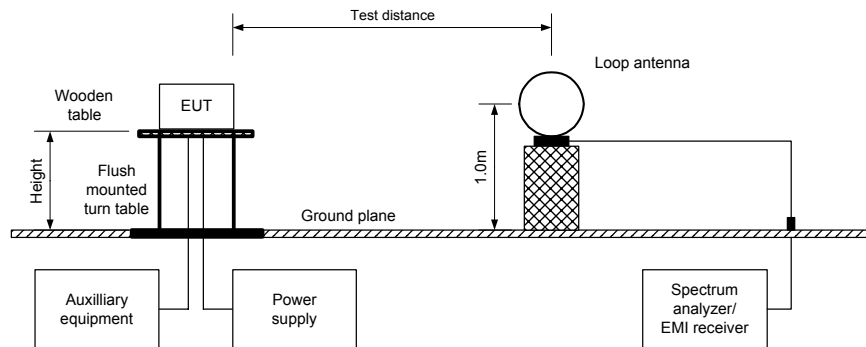
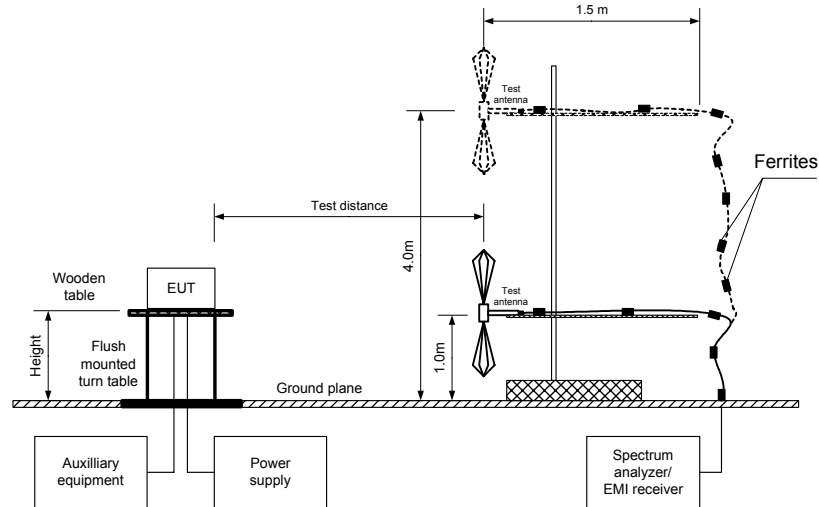

Figure 7.5.2 Setup for spurious emission field strength measurements above 30 MHz



Test specification:		Section 15.247(c), Radiated spurious emissions	
Test procedure:		FR Vol. 62, page 26243, Section 15.247(c) / ANSI C63.4, Section 13.1.4	
Test mode:	Compliance	Verdict: PASS	
Date & Time:	6/6/2006 1:35:17 PM		
Temperature: 23 °C	Air Pressure: 1013 hPa	Relative Humidity: 48 %	Power Supply: 120 VAC
Remarks:			

Table 7.5.2 Field strength of spurious emissions above 1 GHz within restricted bands

ASSIGNED FREQUENCY: 2400 – 2483.5 MHz
 INVESTIGATED FREQUENCY RANGE: 1000 – 25000 MHz
 TEST DISTANCE: 3 m
 MODULATION: OFDM / DSSS
 MODULATING SIGNAL: PRBS
 BIT RATE: 1 Mbps
 DUTY CYCLE: 99 %
 TRANSMITTER OUTPUT POWER SETTINGS: Maximum
 DETECTOR USED: Peak
 RESOLUTION BANDWIDTH: 1000 kHz
 TEST ANTENNA TYPE: Double ridged guide

Frequency, MHz	Antenna		Azimuth, degrees*	Peak field strength(VBW=3 MHz)			Average field strength(VBW=10 Hz)				Verdict
	Polarization	Height, m		Measured, dB(μV/m)	Limit, dB(μV/m)	Margin, dB**	Measured, dB(μV/m)	Calculated, dB(μV/m)	Limit, dB(μV/m)	Margin, dB***	
Low carrier frequency											
All spurious are 20dB below the limit											Pass
Mid carrier frequency											
7311	V	1.3	230	58.00	74.00	-16.00	42.00	42.00	54.00	-13.00	Pass
High carrier frequency											
7386	V	1.3	230	63.00	74.00	-11.00	40.17	40.17	54.00	-13.83	Pass

*- EUT front panel refers to 0 degrees position of turntable.
 **- Margin = Measured field strength - specification limit.
 ***- Margin = Calculated field strength - specification limit,
 where Calculated field strength = Measured field strength + average factor.

Table 7.5.3 Average factor calculation

Transmission pulse		Transmission burst		Transmission train duration, ms	Average factor, dB
Duration, ms	Period, ms	Duration, ms	Period, ms		
99% duty cycle					0

*- Average factor was calculated as follows
 for pulse train shorter than 100 ms:

$$Average\ factor = 20 \times \log_{10} \left(\frac{Pulse\ duration}{Pulse\ period} \times \frac{Burst\ duration}{Train\ duration} \times Number\ of\ bursts\ within\ pulse\ train \right)$$

 for pulse train longer than 100 ms:

$$Average\ factor = 20 \times \log_{10} \left(\frac{Pulse\ duration}{Pulse\ period} \times \frac{Burst\ duration}{100\ ms} \times Number\ of\ bursts\ within\ 100\ ms \right)$$

Test specification:		Section 15.247(c), Radiated spurious emissions	
Test procedure:		FR Vol. 62, page 26243, Section 15.247(c) / ANSI C63.4, Section 13.1.4	
Test mode:	Compliance	Verdict:	PASS
Date & Time:	6/6/2006 1:35:17 PM		
Temperature: 23 °C	Air Pressure: 1013 hPa	Relative Humidity: 48 %	Power Supply: 120 VAC
Remarks:			

Table 7.5.4 Field strength of spurious emissions below 1 GHz within restricted bands

ASSIGNED FREQUENCY: 2400 – 2483.5 MHz
 INVESTIGATED FREQUENCY RANGE: 0.009 – 1000 MHz
 TEST DISTANCE: 3 m
 MODULATION: OFDM / DSSS
 MODULATING SIGNAL: PRBS
 BIT RATE: 1 Mbps
 DUTY CYCLE: 99 %
 TRANSMITTER OUTPUT POWER SETTINGS: Maximum
 RESOLUTION BANDWIDTH: 0.2 kHz (9 kHz – 150 kHz)
 9.0 kHz (150 kHz – 30 MHz)
 120 kHz (30 MHz – 1000 MHz)
 VIDEO BANDWIDTH: > Resolution bandwidth
 TEST ANTENNA TYPE: Active loop (9 kHz – 30 MHz)
 Biconilog (30 MHz – 1000 MHz)

Frequency, MHz	Peak emission, dB(μV/m)	Quasi-peak			Antenna polarization	Antenna height, m	Turn-table position**, degrees	Verdict
		Measured emission, dB(μV/m)	Limit, dB(μV/m)	Margin, dB*				
Low carrier frequency								
All spurious are 20dB below the limit								Pass
Mid carrier frequency								
All spurious are 20dB below the limit								Pass
High carrier frequency								
All spurious are 20dB below the limit								Pass

*- Margin = Measured emission - specification limit.

** - EUT front panel refer to 0 degrees position of turntable.

Table 7.5.5 Restricted bands

MHz	MHz	MHz	MHz	MHz	GHz
0.09 - 0.11	8.37625 - 8.38675	73 - 74.6	399.9 - 410	2690 - 2900	10.6 - 12.7
0.495 - 0.505	8.41425 - 8.41475	74.8 - 75.2	608 - 614	3260 - 3267	13.25 - 13.4
2.1735 - 2.1905	12.29 - 12.293	108 - 121.94	960 - 1240	3332 - 3339	14.47 - 14.5
4.125 - 4.128	12.51975 - 12.52025	123 - 138	1300 - 1427	3345.8 - 3358	15.35 - 16.2
4.17725 - 4.17775	12.57675 - 12.57725	149.9 - 150.05	1435 - 1626.5	3600 - 4400	17.7 - 21.4
4.20725 - 4.20775	13.36 - 13.41	156.52475 - 156.52525	1645.5 - 1646.5	4500 - 5150	22.01 - 23.12
6.215 - 6.218	16.42 - 16.423	156.7 - 156.9	1660 - 1710	5350 - 5460	23.6 - 24
6.26775 - 6.26825	16.69475 - 16.69525	162.0125 - 167.17	1718.8 - 1722.2	7250 - 7750	31.2 - 31.8
6.31175 - 6.31225	16.80425 - 16.80475	167.72 - 173.2	2200 - 2300	8025 - 8500	36.43 - 36.5
8.291 - 8.294	25.5 - 25.67	240 - 285	2310 - 2390	9000 - 9200	Above 38.6
8.362 - 8.366	37.5 - 38.25	322 - 335.4	2483.5 - 2500	9300 - 9500	

Reference numbers of test equipment used

HL 0446	HL 0465	HL 0521	HL 0589	HL 0592	HL 0593	HL 0594	HL 0604
HL 1947	HL 1984	HL 2009					

Full description is given in Appendix A.

Test specification:	Section 15.247(c), Radiated spurious emissions		
Test procedure:	FR Vol. 62, page 26243, Section 15.247(c) / ANSI C63.4, Section 13.1.4		
Test mode:	Compliance	Verdict:	PASS
Date & Time:	6/6/2006 1:35:17 PM		
Temperature: 23 °C	Air Pressure: 1013 hPa	Relative Humidity: 48 %	Power Supply: 120 VAC
Remarks:			

Plot 7.5.1 Radiated emission measurements from 9 to 150 kHz at the low carrier frequency

TEST SITE: Anechoic chamber
 TEST DISTANCE: 3 m
 ANTENNA POLARIZATION: Vertical
 INPUTS: 802.11 b/g + 802.11 a

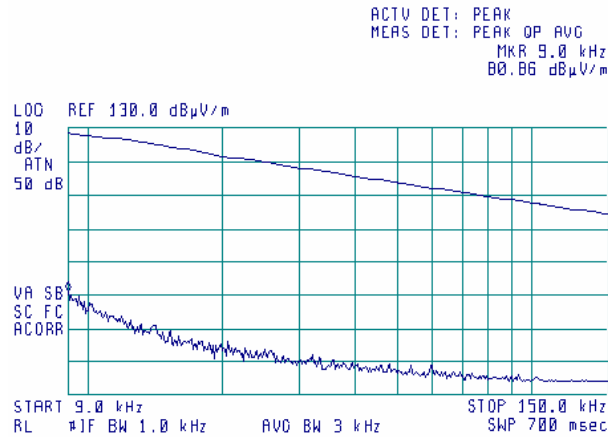

Plot 7.5.2 Radiated emission measurements from 9 to 150 kHz at the mid carrier frequency

TEST SITE: Anechoic chamber
 TEST DISTANCE: 3 m
 ANTENNA POLARIZATION: Vertical
 INPUTS: 802.11 b/g + 802.11 a

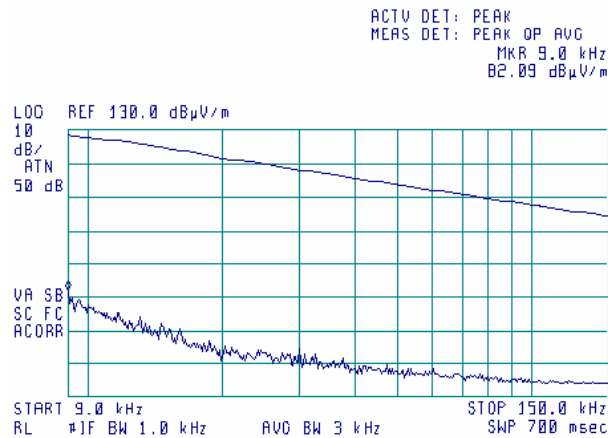

Test specification:	Section 15.247(c), Radiated spurious emissions		
Test procedure:	FR Vol. 62, page 26243, Section 15.247(c) / ANSI C63.4, Section 13.1.4		
Test mode:	Compliance	Verdict:	PASS
Date & Time:	6/6/2006 1:35:17 PM		
Temperature: 23 °C	Air Pressure: 1013 hPa	Relative Humidity: 48 %	Power Supply: 120 VAC
Remarks:			

Plot 7.5.3 Radiated emission measurements from 9 to 150 kHz at the high carrier frequency

TEST SITE: Anechoic chamber
 TEST DISTANCE: 3 m
 ANTENNA POLARIZATION: Vertical
 INPUTS: 802.11 b/g + 802.11 a

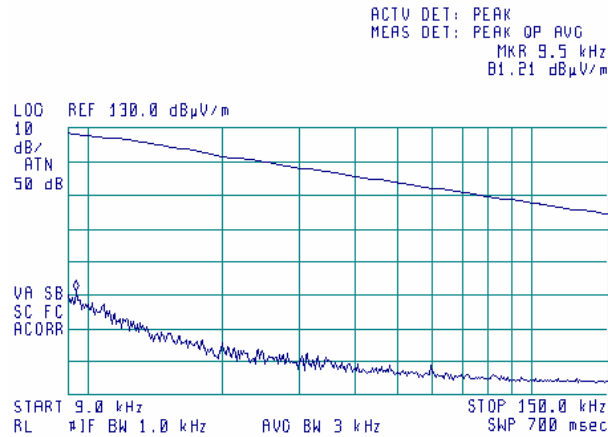

Plot 7.5.4 Radiated emission measurements from 0.15 to 30 MHz at the low carrier frequency

TEST SITE: Anechoic chamber
 TEST DISTANCE: 3 m
 ANTENNA POLARIZATION: Vertical
 INPUTS: 802.11 b/g + 802.11 a

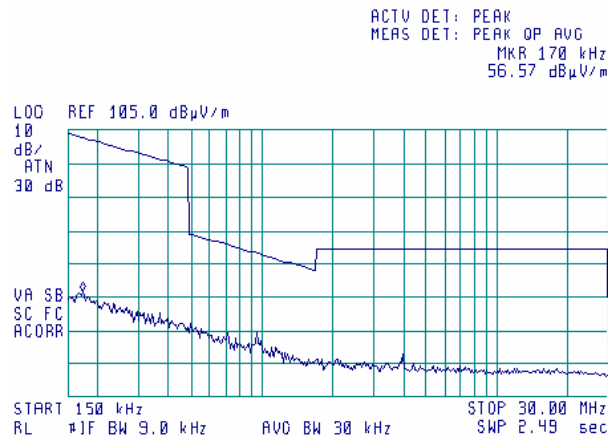

Test specification:	Section 15.247(c), Radiated spurious emissions		
Test procedure:	FR Vol. 62, page 26243, Section 15.247(c) / ANSI C63.4, Section 13.1.4		
Test mode:	Compliance	Verdict:	PASS
Date & Time:	6/6/2006 1:35:17 PM		
Temperature: 23 °C	Air Pressure: 1013 hPa	Relative Humidity: 48 %	Power Supply: 120 VAC
Remarks:			

Plot 7.5.5 Radiated emission measurements from 0.15 to 30 MHz at the mid carrier frequency

TEST SITE: Anechoic chamber
 TEST DISTANCE: 3 m
 ANTENNA POLARIZATION: Vertical
 INPUTS: 802.11 b/g + 802.11 a

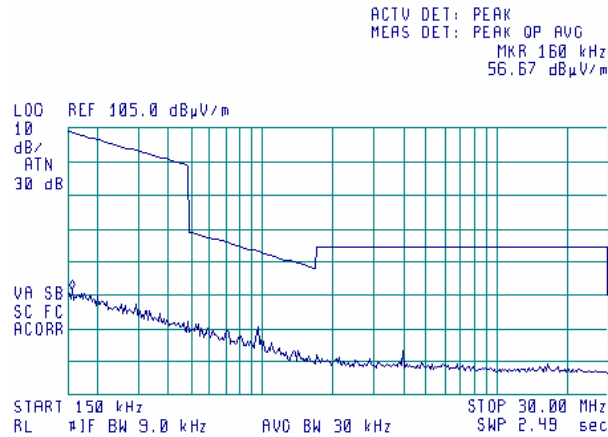

Plot 7.5.6 Radiated emission measurements from 0.15 to 30 MHz at the high carrier frequency

TEST SITE: Anechoic chamber
 TEST DISTANCE: 3 m
 ANTENNA POLARIZATION: Vertical
 INPUTS: 802.11 b/g + 802.11 a

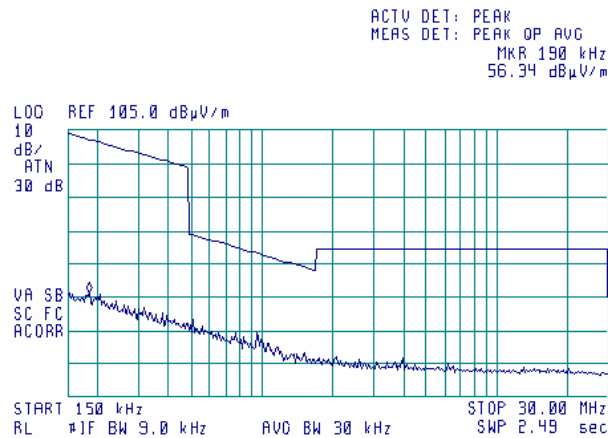

Test specification:		Section 15.247(c), Radiated spurious emissions	
Test procedure:		FR Vol. 62, page 26243, Section 15.247(c) / ANSI C63.4, Section 13.1.4	
Test mode:	Compliance	Verdict:	PASS
Date & Time:	6/6/2006 1:35:17 PM		
Temperature: 23 °C	Air Pressure: 1013 hPa	Relative Humidity: 48 %	Power Supply: 120 VAC
Remarks:			

Plot 7.5.7 Radiated emission measurements from 30 to 1000 MHz at the low carrier frequency

TEST SITE: Anechoic chamber
 TEST DISTANCE: 3 m
 ANTENNA POLARIZATION: Vertical and Horizontal
 INPUTS: 802.11 b/g + 802.11 a

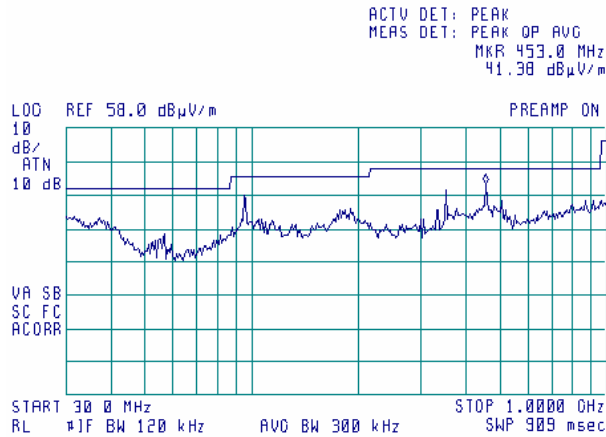

Plot 7.5.8 Radiated emission measurements from 30 to 1000 MHz at the mid carrier frequency

TEST SITE: Anechoic chamber
 TEST DISTANCE: 3 m
 ANTENNA POLARIZATION: Vertical and Horizontal
 INPUTS: 802.11 b/g + 802.11 a

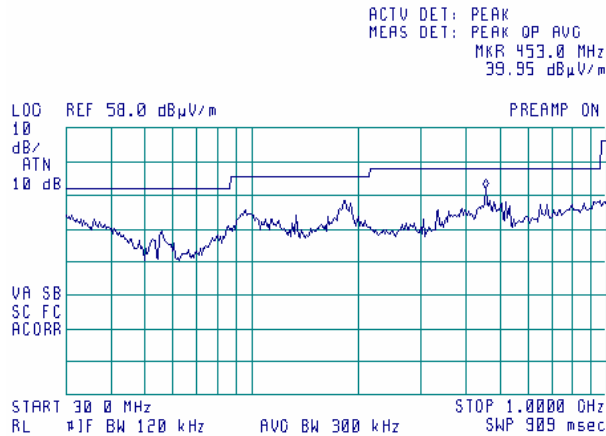

Test specification:	Section 15.247(c), Radiated spurious emissions		
Test procedure:	FR Vol. 62, page 26243, Section 15.247(c) / ANSI C63.4, Section 13.1.4		
Test mode:	Compliance	Verdict: PASS	
Date & Time:	6/6/2006 1:35:17 PM		
Temperature: 23 °C	Air Pressure: 1013 hPa	Relative Humidity: 48 %	Power Supply: 120 VAC
Remarks:			

Plot 7.5.9 Radiated emission measurements from 30 to 1000 MHz at the high carrier frequency

TEST SITE: Anechoic chamber
 TEST DISTANCE: 3 m
 ANTENNA POLARIZATION: Vertical and Horizontal
 INPUTS: 802.11 b/g + 802.11 a

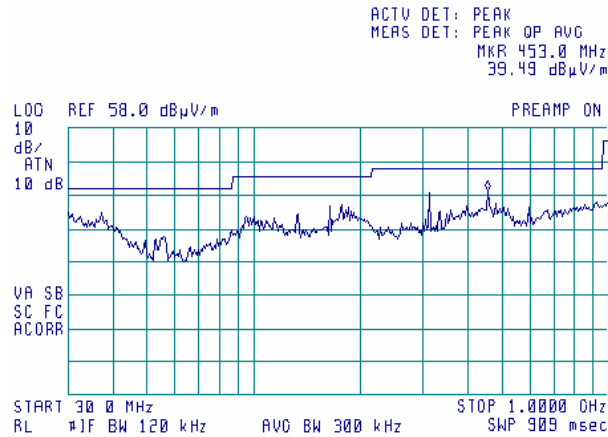

Test specification:	Section 15.247(c), Radiated spurious emissions		
Test procedure:	FR Vol. 62, page 26243, Section 15.247(c) / ANSI C63.4, Section 13.1.4		
Test mode:	Compliance	Verdict:	PASS
Date & Time:	6/6/2006 1:35:17 PM		
Temperature: 23 °C	Air Pressure: 1013 hPa	Relative Humidity: 48 %	Power Supply: 120 VAC
Remarks:			

Plot 7.5.10 Radiated emission measurements from 1000 to 2350 MHz at the low carrier frequency

TEST SITE: Anechoic chamber
 TEST DISTANCE: 3 m
 ANTENNA POLARIZATION: Vertical and Horizontal
 INPUTS: 802.11 b/g + 802.11 a
 DETECTOR: Peak

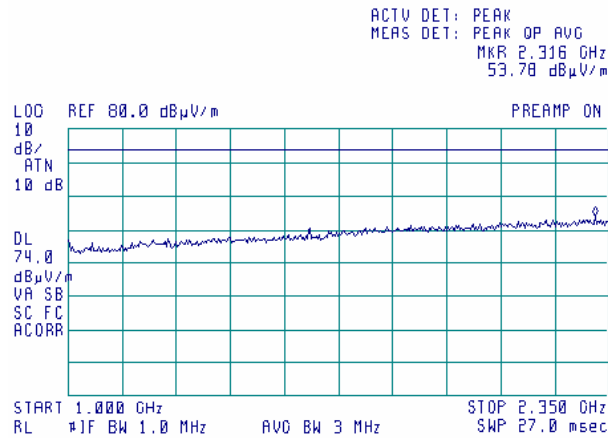

Plot 7.5.11 Radiated emission measurements from 1000 to 2350 MHz at the low carrier frequency

TEST SITE: Anechoic chamber
 TEST DISTANCE: 3 m
 ANTENNA POLARIZATION: Vertical and Horizontal
 INPUTS: 802.11 b/g + 802.11 a
 DETECTOR: Average

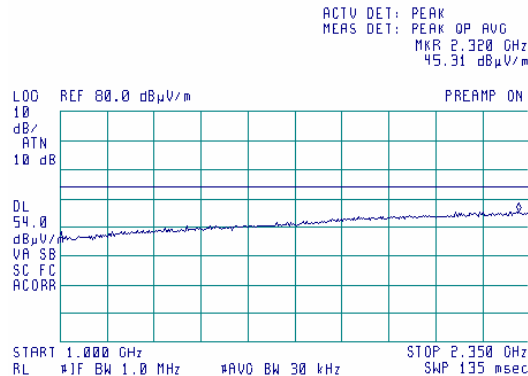

Test specification:	Section 15.247(c), Radiated spurious emissions		
Test procedure:	FR Vol. 62, page 26243, Section 15.247(c) / ANSI C63.4, Section 13.1.4		
Test mode:	Compliance	Verdict:	PASS
Date & Time:	6/6/2006 1:35:17 PM		
Temperature: 23 °C	Air Pressure: 1013 hPa	Relative Humidity: 48 %	Power Supply: 120 VAC
Remarks:			

Plot 7.5.12 Radiated emission measurements from 2350 to 2390 MHz at the low carrier frequency

TEST SITE: Anechoic chamber
 TEST DISTANCE: 3 m
 ANTENNA POLARIZATION: Vertical and Horizontal
 INPUTS: 802.11 b/g + 802.11 a
 DETECTOR: Peak

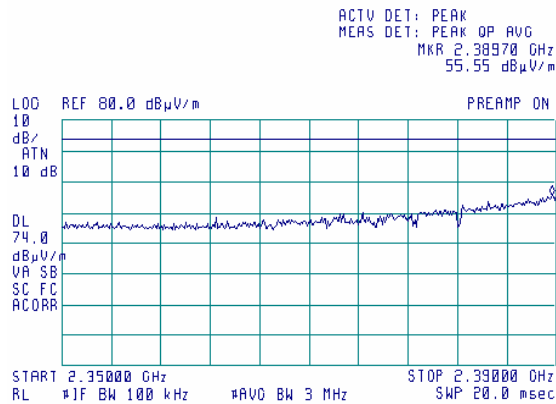

Note: Signal field strength = SA reading + BW factor = 55.55 dBµV/m + 10log(1MHz/100kHz) = 55.55 dBµV/m + 10 dB = 65.55 dBµV/m

Plot 7.5.13 Radiated emission measurements from 2350 to 2390 MHz at the low carrier frequency

TEST SITE: Anechoic chamber
 TEST DISTANCE: 3 m
 ANTENNA POLARIZATION: Vertical and Horizontal
 INPUTS: 802.11 b/g + 802.11 a
 DETECTOR: Average

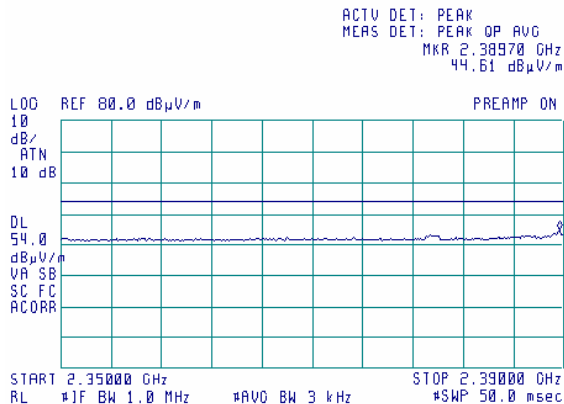

Test specification:	Section 15.247(c), Radiated spurious emissions		
Test procedure:	FR Vol. 62, page 26243, Section 15.247(c) / ANSI C63.4, Section 13.1.4		
Test mode:	Compliance	Verdict:	PASS
Date & Time:	6/6/2006 1:35:17 PM		
Temperature: 23 °C	Air Pressure: 1013 hPa	Relative Humidity: 48 %	Power Supply: 120 VAC
Remarks:			

Plot 7.5.14 Radiated emission measurements from 1000 to 2390 MHz at the mid carrier frequency

TEST SITE: Anechoic chamber
 TEST DISTANCE: 3 m
 ANTENNA POLARIZATION: Vertical and Horizontal
 INPUTS: 802.11 b/g + 802.11 a
 DETECTOR: Peak

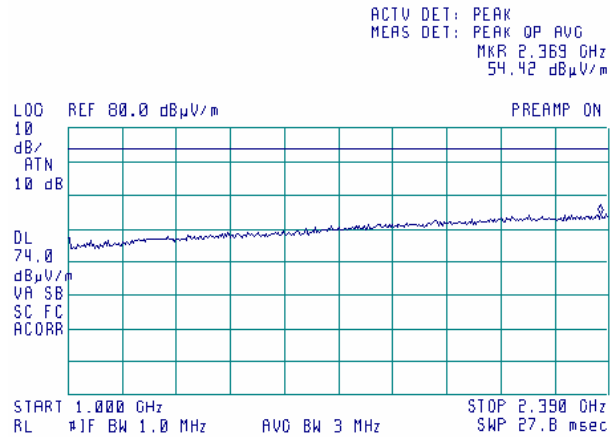

Plot 7.5.15 Radiated emission measurements from 1000 to 2390 MHz at the mid carrier frequency

TEST SITE: Anechoic chamber
 TEST DISTANCE: 3 m
 ANTENNA POLARIZATION: Vertical and Horizontal
 INPUTS: 802.11 b/g + 802.11 a
 DETECTOR: Average

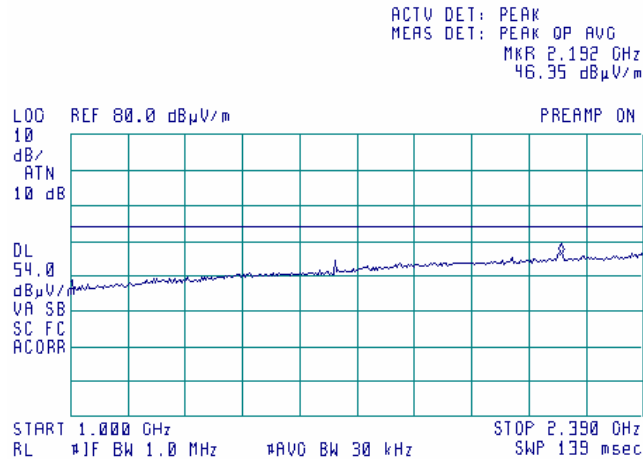

Test specification: Section 15.247(c), Radiated spurious emissions			
Test procedure: FR Vol. 62, page 26243, Section 15.247(c) / ANSI C63.4, Section 13.1.4			
Test mode: Compliance	Verdict: PASS		
Date & Time: 6/6/2006 1:35:17 PM			
Temperature: 23 °C	Air Pressure: 1013 hPa	Relative Humidity: 48 %	Power Supply: 120 VAC
Remarks:			

Plot 7.5.16 Radiated emission measurements from 1000 to 2390 MHz at the high carrier frequency

TEST SITE: Anechoic chamber
 TEST DISTANCE: 3 m
 ANTENNA POLARIZATION: Vertical and Horizontal
 INPUTS: 802.11 b/g + 802.11 a
 DETECTOR: Peak

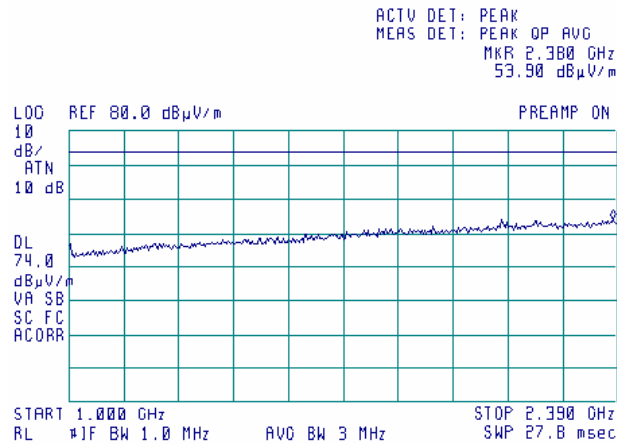

Plot 7.5.17 Radiated emission measurements from 1000 to 2390 MHz at the high carrier frequency

TEST SITE: Anechoic chamber
 TEST DISTANCE: 3 m
 ANTENNA POLARIZATION: Vertical and Horizontal
 INPUTS: 802.11 b/g + 802.11 a
 DETECTOR: Average

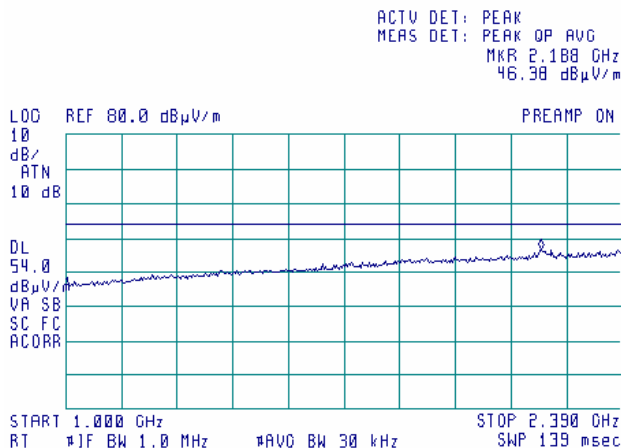

Test specification:	Section 15.247(c), Radiated spurious emissions		
Test procedure:	FR Vol. 62, page 26243, Section 15.247(c) / ANSI C63.4, Section 13.1.4		
Test mode:	Compliance	Verdict:	PASS
Date & Time:	6/6/2006 1:35:17 PM		
Temperature: 23 °C	Air Pressure: 1013 hPa	Relative Humidity: 48 %	Power Supply: 120 VAC
Remarks:			

Plot 7.5.18 Radiated emission measurements from 2483.5 to 2500 MHz at the low carrier frequency

TEST SITE: Anechoic chamber
 TEST DISTANCE: 3 m
 ANTENNA POLARIZATION: Vertical and Horizontal
 INPUTS: 802.11 b/g + 802.11 a
 DETECTOR: Peak

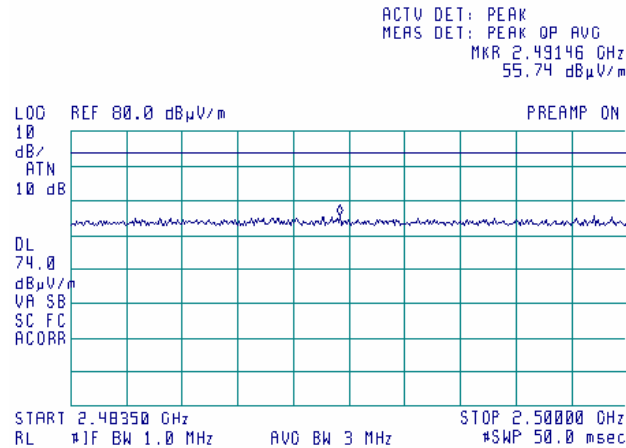

Plot 7.5.19 Radiated emission measurements from 2483.5 to 2500 MHz at the low carrier frequency

TEST SITE: Anechoic chamber
 TEST DISTANCE: 3 m
 ANTENNA POLARIZATION: Vertical and Horizontal
 INPUTS: 802.11 b/g + 802.11 a
 DETECTOR: Average

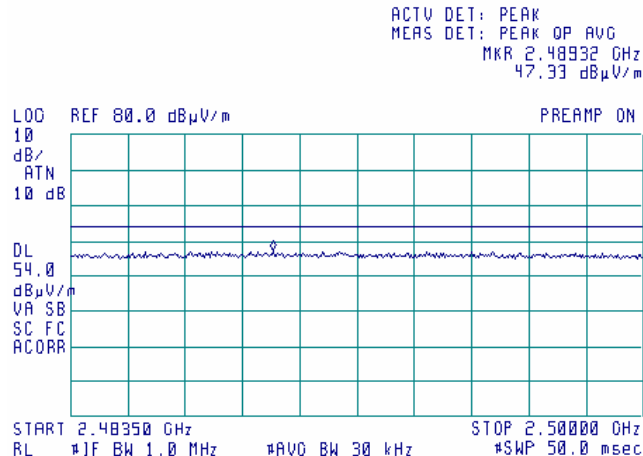

Test specification:	Section 15.247(c), Radiated spurious emissions		
Test procedure:	FR Vol. 62, page 26243, Section 15.247(c) / ANSI C63.4, Section 13.1.4		
Test mode:	Compliance	Verdict:	PASS
Date & Time:	6/6/2006 1:35:17 PM		
Temperature: 23 °C	Air Pressure: 1013 hPa	Relative Humidity: 48 %	Power Supply: 120 VAC
Remarks:			

Plot 7.5.20 Radiated emission measurements from 2483.5 to 2500 MHz at the mid carrier frequency

TEST SITE: Anechoic chamber
 TEST DISTANCE: 3 m
 ANTENNA POLARIZATION: Vertical and Horizontal
 INPUTS: 802.11 b/g + 802.11 a
 DETECTOR: Peak

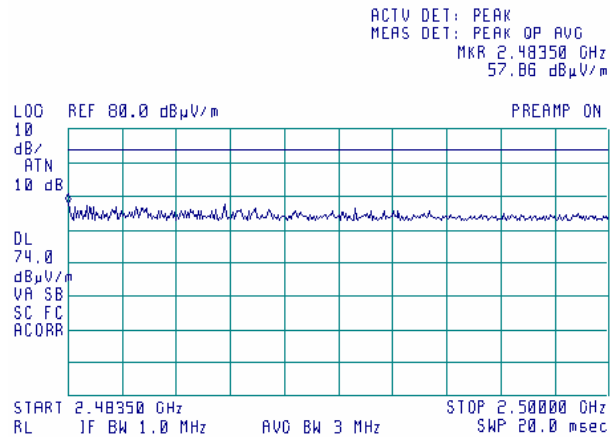

Plot 7.5.21 Radiated emission measurements from 2483.5 to 2500 MHz at the mid carrier frequency

TEST SITE: Anechoic chamber
 TEST DISTANCE: 3 m
 ANTENNA POLARIZATION: Vertical and Horizontal
 INPUTS: 802.11 b/g + 802.11 a
 DETECTOR: Average

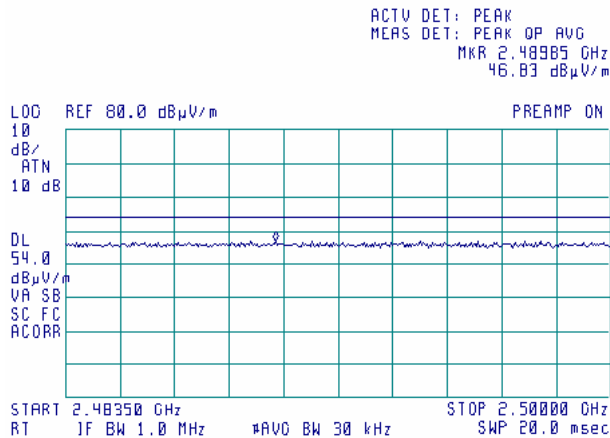

Test specification:	Section 15.247(c), Radiated spurious emissions		
Test procedure:	FR Vol. 62, page 26243, Section 15.247(c) / ANSI C63.4, Section 13.1.4		
Test mode:	Compliance	Verdict:	PASS
Date & Time:	6/6/2006 1:35:17 PM		
Temperature: 23 °C	Air Pressure: 1013 hPa	Relative Humidity: 48 %	Power Supply: 120 VAC
Remarks:			

Plot 7.5.22 Radiated emission measurements from 2483.5 to 2500 MHz at the high carrier frequency

TEST SITE: Anechoic chamber
 TEST DISTANCE: 3 m
 ANTENNA POLARIZATION: Vertical and Horizontal
 INPUTS: 802.11 b/g + 802.11 a
 DETECTOR: Peak

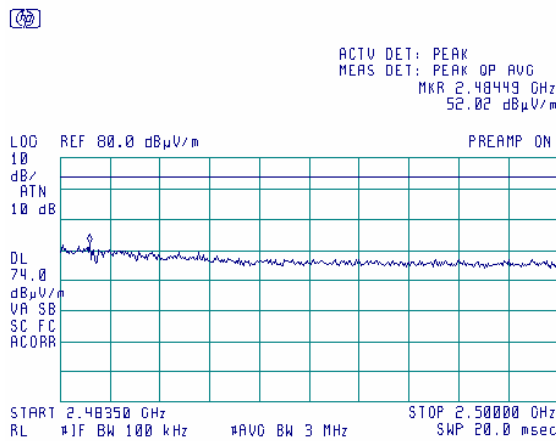

Note: Signal field strength = SA reading + BW factor = 52.02 dBμV/m + 10log(1MHz/100kHz) = 52.02 dBμV/m + 10 dB = 62.02 dBμV/m

Plot 7.5.23 Radiated emission measurements from 2483.5 to 2500 MHz at the high carrier frequency

TEST SITE: Anechoic chamber
 TEST DISTANCE: 3 m
 ANTENNA POLARIZATION: Vertical and Horizontal
 INPUTS: 802.11 b/g + 802.11 a
 DETECTOR: Average

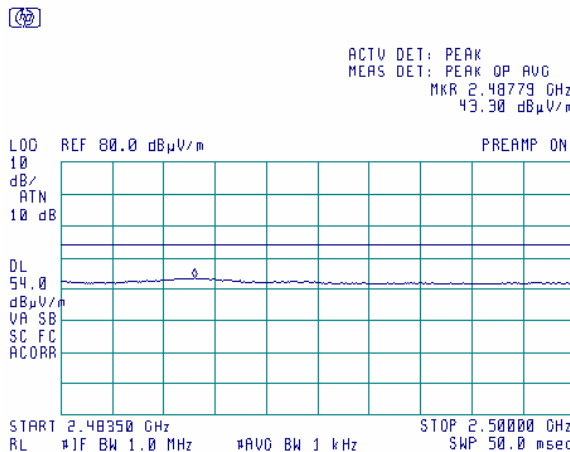

Test specification:		Section 15.247(c), Radiated spurious emissions	
Test procedure: FR Vol. 62, page 26243, Section 15.247(c) / ANSI C63.4, Section 13.1.4			
Test mode: Compliance		Verdict: PASS	
Date & Time: 6/6/2006 1:35:17 PM			
Temperature: 23 °C	Air Pressure: 1013 hPa	Relative Humidity: 48 %	Power Supply: 120 VAC
Remarks:			

Plot 7.5.24 Radiated emission measurements from 2500 to 2900 MHz at the low carrier frequency

TEST SITE: Anechoic chamber
 TEST DISTANCE: 3 m
 ANTENNA POLARIZATION: Vertical and Horizontal
 INPUTS: 802.11 b/g + 802.11 a
 DETECTOR: Peak

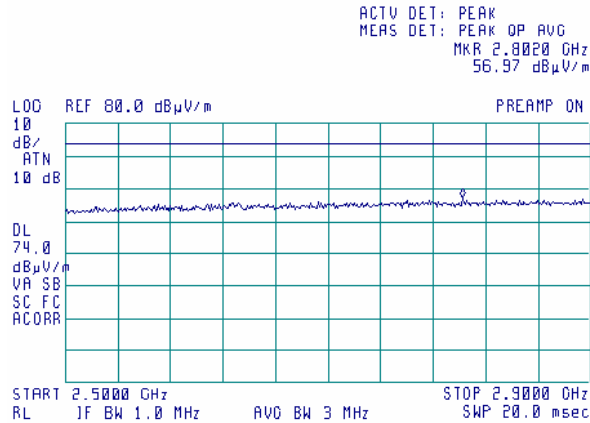

Plot 7.5.25 Radiated emission measurements from 2500 to 2900 MHz at the low carrier frequency

TEST SITE: Anechoic chamber
 TEST DISTANCE: 3 m
 ANTENNA POLARIZATION: Vertical and Horizontal
 INPUTS: 802.11 b/g + 802.11 a
 DETECTOR: Average

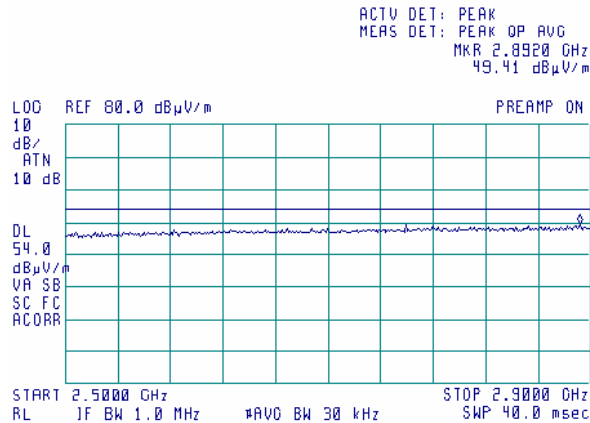

Test specification:	Section 15.247(c), Radiated spurious emissions		
Test procedure:	FR Vol. 62, page 26243, Section 15.247(c) / ANSI C63.4, Section 13.1.4		
Test mode:	Compliance	Verdict:	PASS
Date & Time:	6/6/2006 1:35:17 PM		
Temperature: 23 °C	Air Pressure: 1013 hPa	Relative Humidity: 48 %	Power Supply: 120 VAC
Remarks:			

Plot 7.5.26 Radiated emission measurements from 2500 to 2900 MHz at the mid carrier frequency

TEST SITE: Anechoic chamber
 TEST DISTANCE: 3 m
 ANTENNA POLARIZATION: Vertical and Horizontal
 INPUTS: 802.11 b/g + 802.11 a
 DETECTOR: Peak

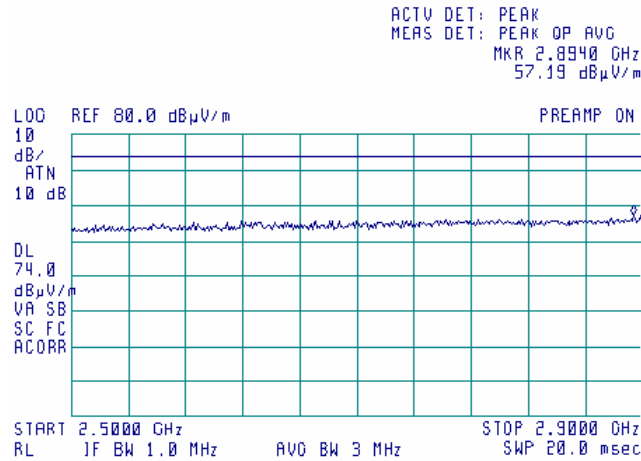

Plot 7.5.27 Radiated emission measurements from 2500 to 2900 MHz at the mid carrier frequency

TEST SITE: Anechoic chamber
 TEST DISTANCE: 3 m
 ANTENNA POLARIZATION: Vertical and Horizontal
 INPUTS: 802.11 b/g + 802.11 a
 DETECTOR: Average

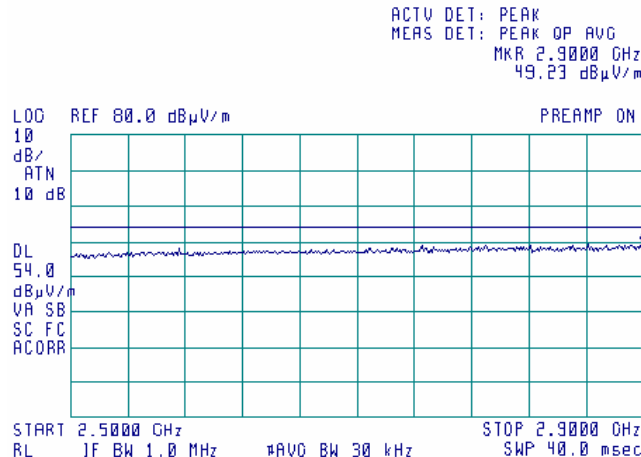

Test specification:	Section 15.247(c), Radiated spurious emissions		
Test procedure:	FR Vol. 62, page 26243, Section 15.247(c) / ANSI C63.4, Section 13.1.4		
Test mode:	Compliance	Verdict:	PASS
Date & Time:	6/6/2006 1:35:17 PM		
Temperature: 23 °C	Air Pressure: 1013 hPa	Relative Humidity: 48 %	Power Supply: 120 VAC
Remarks:			

Plot 7.5.28 Radiated emission measurements from 2500 to 2900 MHz at the high carrier frequency

TEST SITE: Anechoic chamber
 TEST DISTANCE: 3 m
 ANTENNA POLARIZATION: Vertical and Horizontal
 INPUTS: 802.11 b/g + 802.11 a
 DETECTOR: Peak

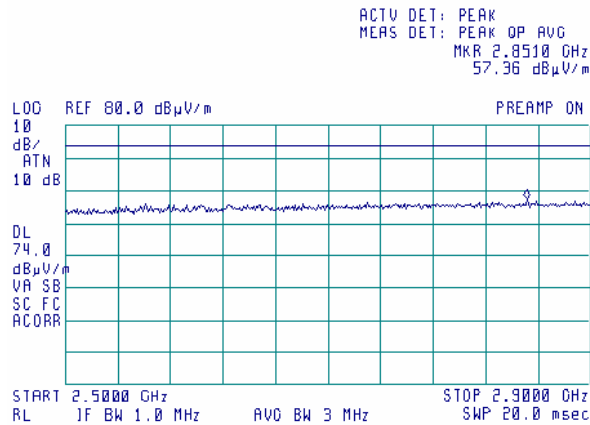

Plot 7.5.29 Radiated emission measurements from 2500 to 2900 MHz at the high carrier frequency

TEST SITE: Anechoic chamber
 TEST DISTANCE: 3 m
 ANTENNA POLARIZATION: Vertical and Horizontal
 INPUTS: 802.11 b/g + 802.11 a
 DETECTOR: Average

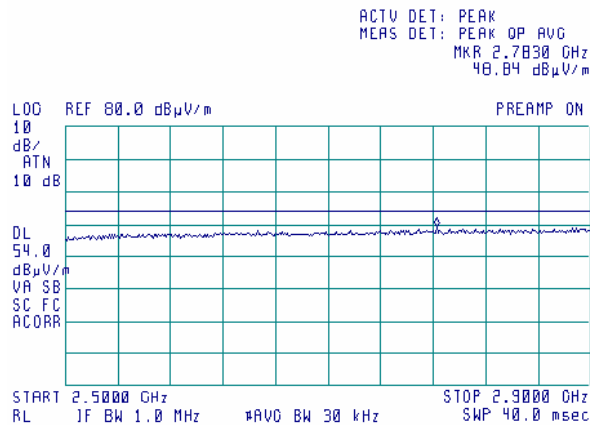

Test specification:	Section 15.247(c), Radiated spurious emissions		
Test procedure:	FR Vol. 62, page 26243, Section 15.247(c) / ANSI C63.4, Section 13.1.4		
Test mode:	Compliance	Verdict:	PASS
Date & Time:	6/6/2006 1:35:17 PM		
Temperature: 23 °C	Air Pressure: 1013 hPa	Relative Humidity: 48 %	Power Supply: 120 VAC
Remarks:			

Plot 7.5.30 Radiated emission measurements from 2900 to 4000 MHz at the low carrier frequency

TEST SITE: Anechoic chamber
 TEST DISTANCE: 3 m
 ANTENNA POLARIZATION: Vertical and Horizontal
 INPUTS: 802.11 b/g + 802.11 a

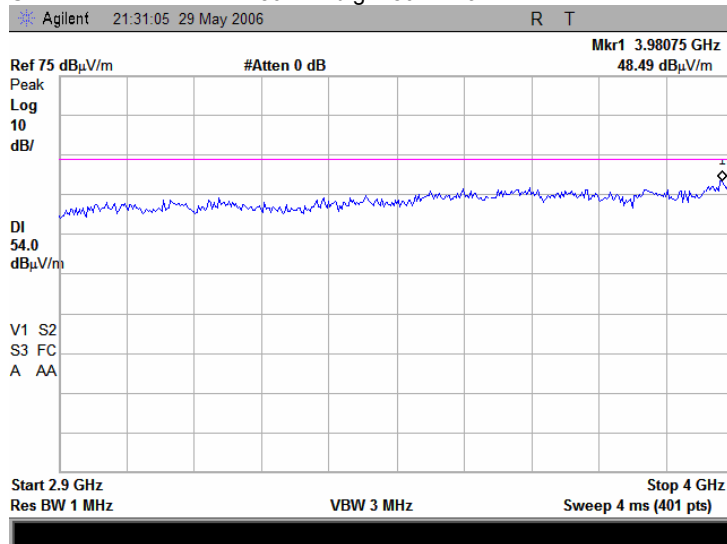

Plot 7.5.31 Radiated emission measurements from 2900 to 4000 MHz at the mid carrier frequency

TEST SITE: Anechoic chamber
 TEST DISTANCE: 3 m
 ANTENNA POLARIZATION: Vertical and Horizontal
 INPUTS: 802.11 b/g + 802.11 a

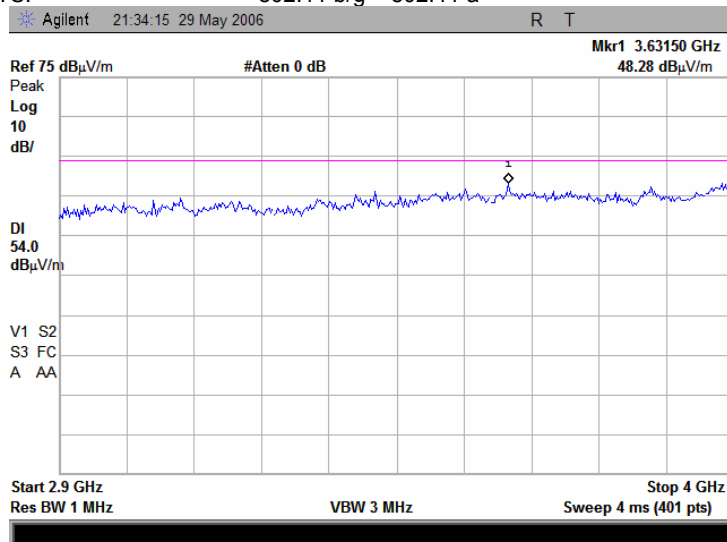

Test specification:	Section 15.247(c), Radiated spurious emissions		
Test procedure:	FR Vol. 62, page 26243, Section 15.247(c) / ANSI C63.4, Section 13.1.4		
Test mode:	Compliance	Verdict:	PASS
Date & Time:	6/6/2006 1:35:17 PM		
Temperature: 23 °C	Air Pressure: 1013 hPa	Relative Humidity: 48 %	Power Supply: 120 VAC
Remarks:			

Plot 7.5.32 Radiated emission measurements from 2900 to 4000 MHz at the high carrier frequency

TEST SITE: Anechoic chamber
 TEST DISTANCE: 3 m
 ANTENNA POLARIZATION: Vertical and Horizontal
 INPUTS: 802.11 b/g + 802.11 a

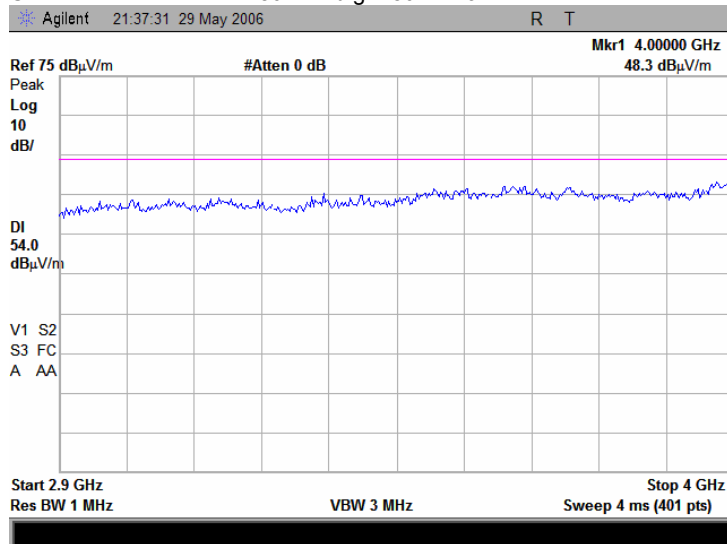

Plot 7.5.33 Radiated emission measurements from 4000 to 5150 MHz at the low carrier frequency

TEST SITE: Anechoic chamber
 TEST DISTANCE: 3 m
 ANTENNA POLARIZATION: Vertical and Horizontal
 INPUTS: 802.11 b/g + 802.11 a

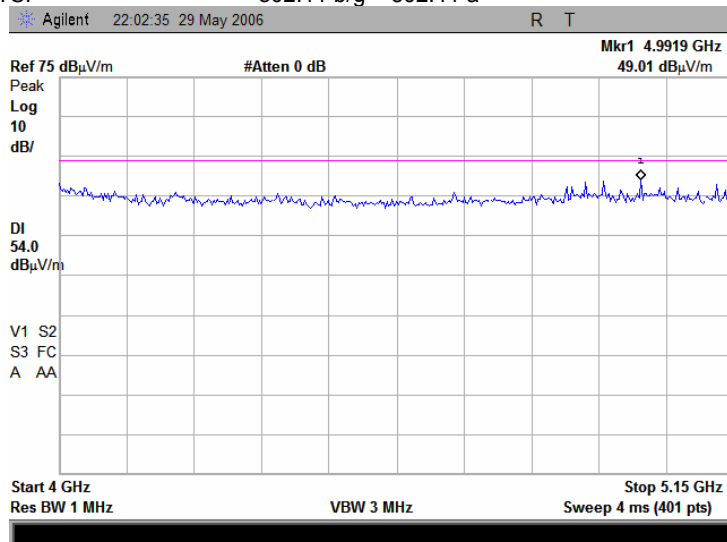

Test specification: Section 15.247(c), Radiated spurious emissions			
Test procedure: FR Vol. 62, page 26243, Section 15.247(c) / ANSI C63.4, Section 13.1.4			
Test mode: Compliance	Verdict: PASS		
Date & Time: 6/6/2006 1:35:17 PM			
Temperature: 23 °C	Air Pressure: 1013 hPa	Relative Humidity: 48 %	Power Supply: 120 VAC
Remarks:			

Plot 7.5.34 Radiated emission measurements from 4000 to 5150 MHz at the mid carrier frequency

TEST SITE: Anechoic chamber
 TEST DISTANCE: 3 m
 ANTENNA POLARIZATION: Vertical and Horizontal
 INPUTS: 802.11 b/g + 802.11 a

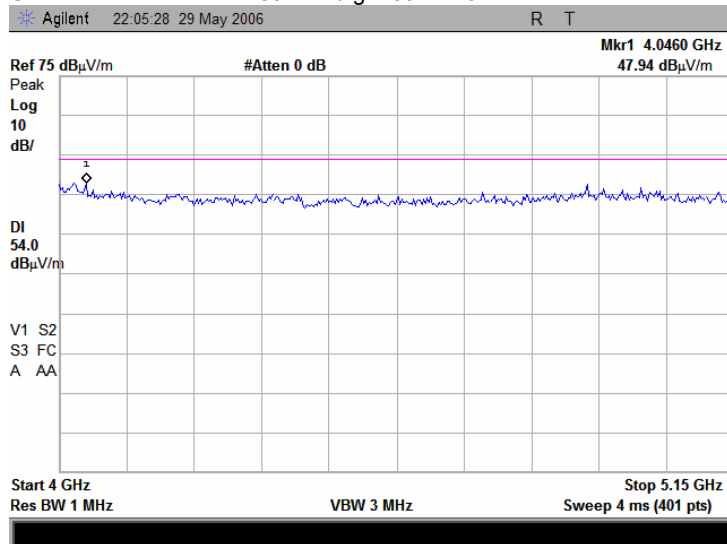

Plot 7.5.35 Radiated emission measurements from 4000 to 5150 MHz at the high carrier frequency

TEST SITE: Anechoic chamber
 TEST DISTANCE: 3 m
 ANTENNA POLARIZATION: Vertical and Horizontal
 INPUTS: 802.11 b/g + 802.11 a

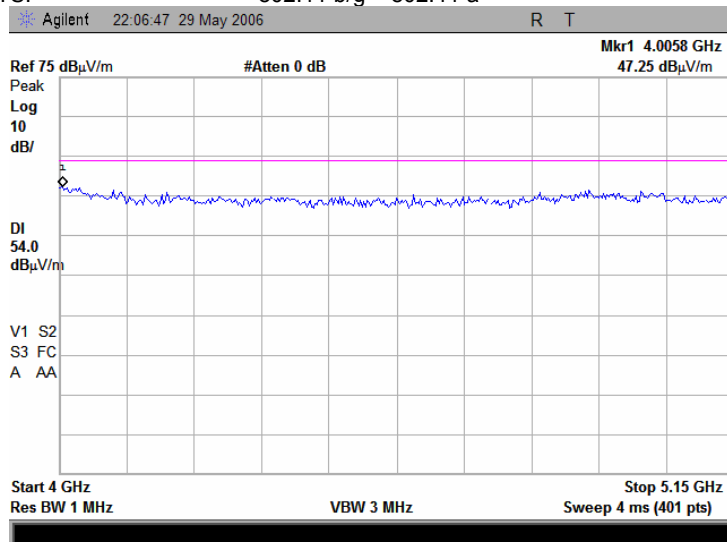

Test specification:	Section 15.247(c), Radiated spurious emissions		
Test procedure:	FR Vol. 62, page 26243, Section 15.247(c) / ANSI C63.4, Section 13.1.4		
Test mode:	Compliance	Verdict:	PASS
Date & Time:	6/6/2006 1:35:17 PM		
Temperature: 23 °C	Air Pressure: 1013 hPa	Relative Humidity: 48 %	Power Supply: 120 VAC
Remarks:			

Plot 7.5.36 Radiated emission measurements from 5350 to 5460 MHz at the low carrier frequency

TEST SITE: Anechoic chamber
 TEST DISTANCE: 3 m
 ANTENNA POLARIZATION: Vertical and Horizontal
 INPUTS: 802.11 b/g + 802.11 a

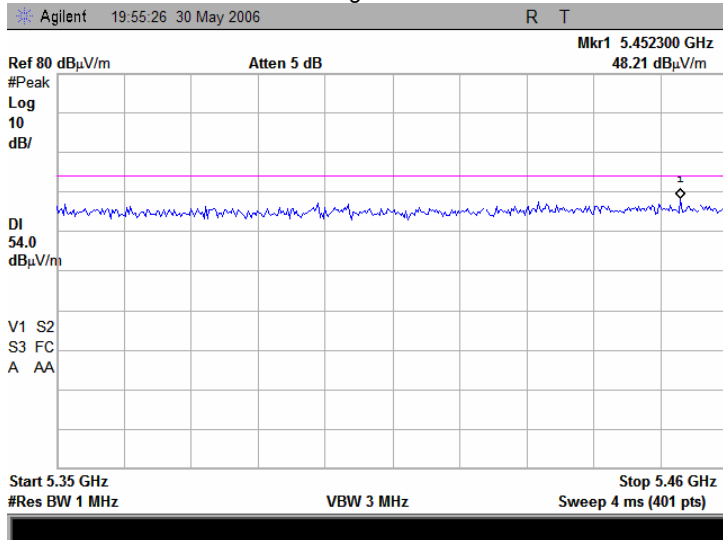

Plot 7.5.37 Radiated emission measurements from 5350 to 5460 MHz at the mid carrier frequency

TEST SITE: Anechoic chamber
 TEST DISTANCE: 3 m
 ANTENNA POLARIZATION: Vertical and Horizontal
 INPUTS: 802.11 b/g + 802.11 a

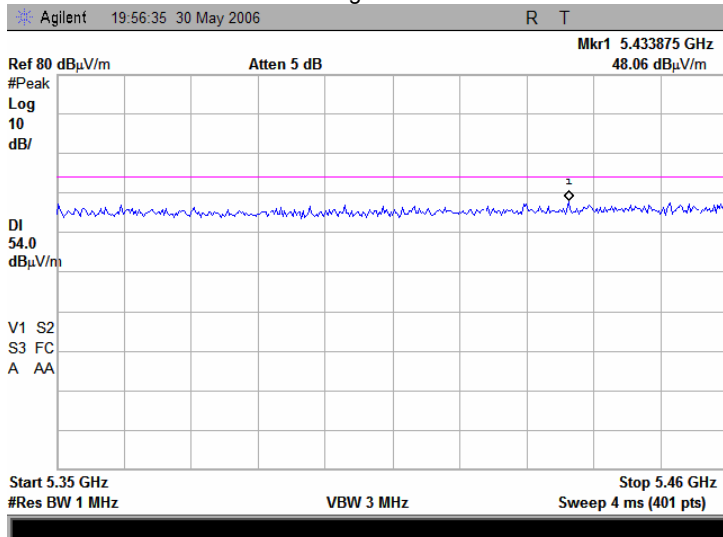

Test specification:	Section 15.247(c), Radiated spurious emissions		
Test procedure:	FR Vol. 62, page 26243, Section 15.247(c) / ANSI C63.4, Section 13.1.4		
Test mode:	Compliance	Verdict:	PASS
Date & Time:	6/6/2006 1:35:17 PM		
Temperature: 23 °C	Air Pressure: 1013 hPa	Relative Humidity: 48 %	Power Supply: 120 VAC
Remarks:			

Plot 7.5.38 Radiated emission measurements from 5350 to 5460 MHz at the high carrier frequency

TEST SITE: Anechoic chamber
 TEST DISTANCE: 3 m
 ANTENNA POLARIZATION: Vertical and Horizontal
 INPUTS: 802.11 b/g + 802.11 a

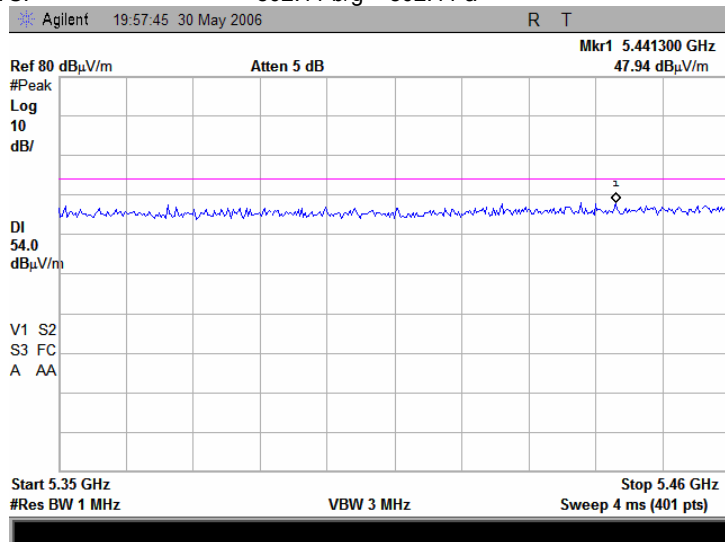

Test specification:	Section 15.247(c), Radiated spurious emissions		
Test procedure:	FR Vol. 62, page 26243, Section 15.247(c) / ANSI C63.4, Section 13.1.4		
Test mode:	Compliance	Verdict:	PASS
Date & Time:	6/6/2006 1:35:17 PM		
Temperature: 23 °C	Air Pressure: 1013 hPa	Relative Humidity: 48 %	Power Supply: 120 VAC
Remarks:			

Plot 7.5.39 Radiated emission measurements from 5.46 to 8.0 GHz at the low carrier frequency

TEST SITE: Anechoic chamber
 TEST DISTANCE: 3 m
 ANTENNA POLARIZATION: Vertical and Horizontal
 INPUTS: 802.11 b/g + 802.11 a
 DETECTOR: Peak

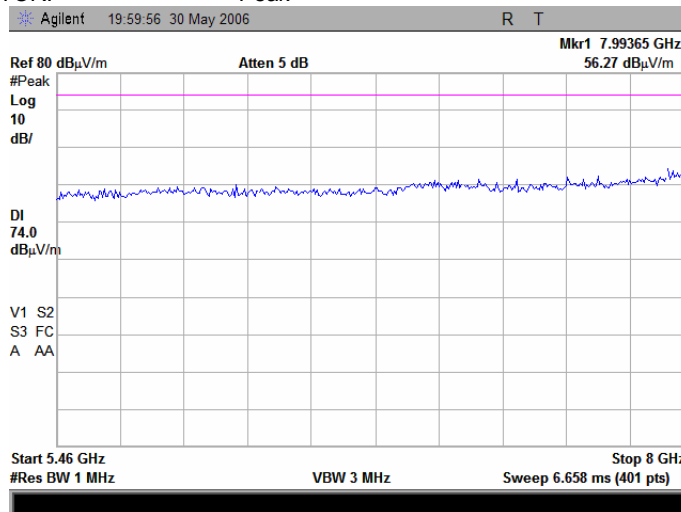

Plot 7.5.40 Radiated emission measurements from 5.46 to 8.0 GHz at the low carrier frequency

TEST SITE: Anechoic chamber
 TEST DISTANCE: 3 m
 ANTENNA POLARIZATION: Vertical and Horizontal
 INPUTS: 802.11 b/g + 802.11 a
 DETECTOR: Average

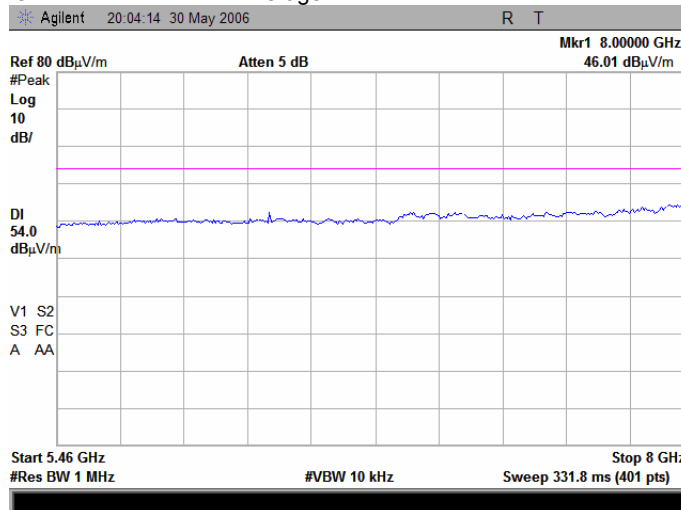

Test specification:	Section 15.247(c), Radiated spurious emissions		
Test procedure:	FR Vol. 62, page 26243, Section 15.247(c) / ANSI C63.4, Section 13.1.4		
Test mode:	Compliance	Verdict:	PASS
Date & Time:	6/6/2006 1:35:17 PM		
Temperature: 23 °C	Air Pressure: 1013 hPa	Relative Humidity: 48 %	Power Supply: 120 VAC
Remarks:			

Plot 7.5.41 Radiated emission measurements from 5.46 to 8.0 GHz at the mid carrier frequency

TEST SITE: Anechoic chamber
 TEST DISTANCE: 3 m
 ANTENNA POLARIZATION: Vertical and Horizontal
 INPUTS: 802.11 b/g + 802.11 a
 DETECTOR: Peak

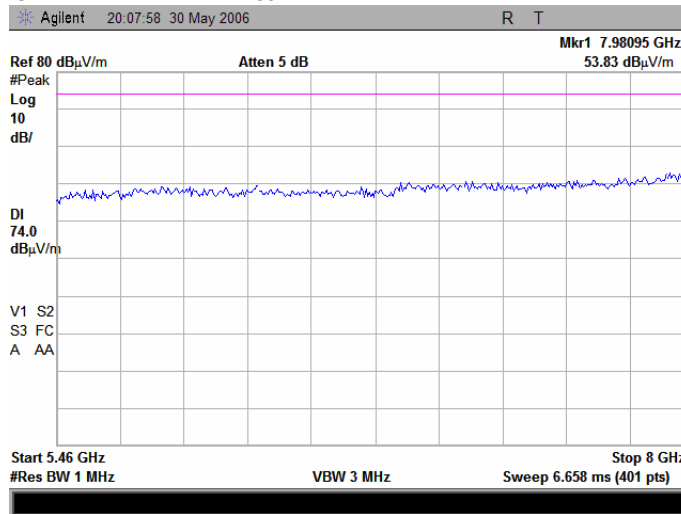

Plot 7.5.42 Radiated emission measurements from 5.46 to 8.0 GHz at the mid carrier frequency

TEST SITE: Anechoic chamber
 TEST DISTANCE: 3 m
 ANTENNA POLARIZATION: Vertical and Horizontal
 INPUTS: 802.11 b/g + 802.11 a
 DETECTOR: Average

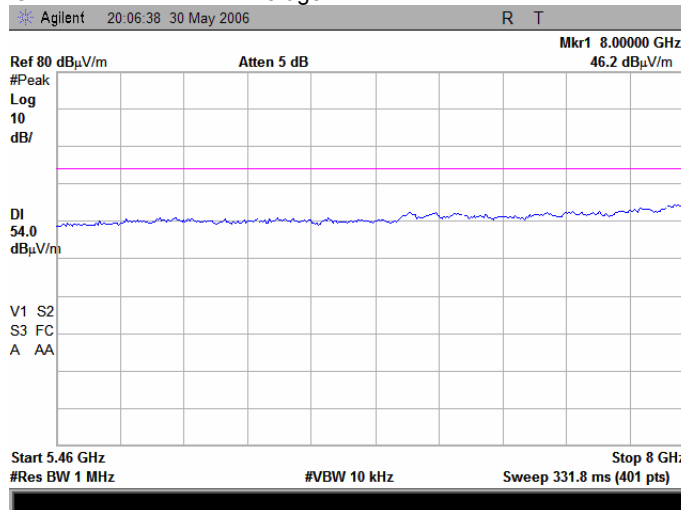

Test specification:	Section 15.247(c), Radiated spurious emissions		
Test procedure:	FR Vol. 62, page 26243, Section 15.247(c) / ANSI C63.4, Section 13.1.4		
Test mode:	Compliance	Verdict:	PASS
Date & Time:	6/6/2006 1:35:17 PM		
Temperature: 23 °C	Air Pressure: 1013 hPa	Relative Humidity: 48 %	Power Supply: 120 VAC
Remarks:			

Plot 7.5.43 Radiated emission measurements from 5.46 to 8.0 GHz at the high carrier frequency

TEST SITE: Anechoic chamber
 TEST DISTANCE: 3 m
 ANTENNA POLARIZATION: Vertical and Horizontal
 INPUTS: 802.11 b/g + 802.11 a
 DETECTOR: Peak

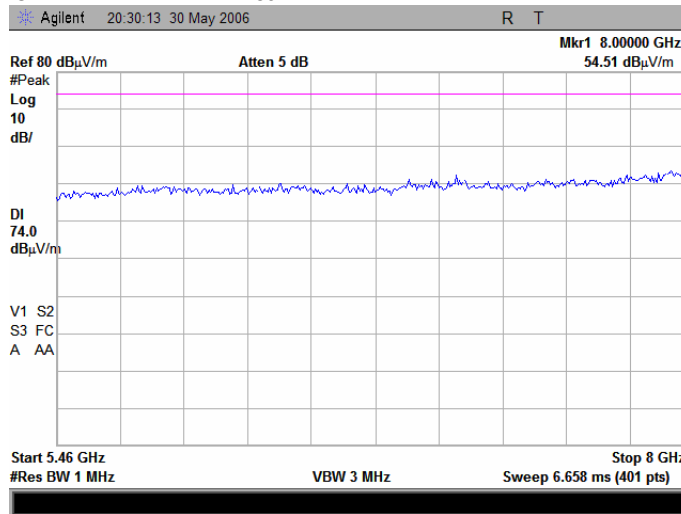

Plot 7.5.44 Radiated emission measurements from 5.46 to 8.0 GHz at the high carrier frequency

TEST SITE: Anechoic chamber
 TEST DISTANCE: 3 m
 ANTENNA POLARIZATION: Vertical and Horizontal
 INPUTS: 802.11 b/g + 802.11 a
 DETECTOR: Average

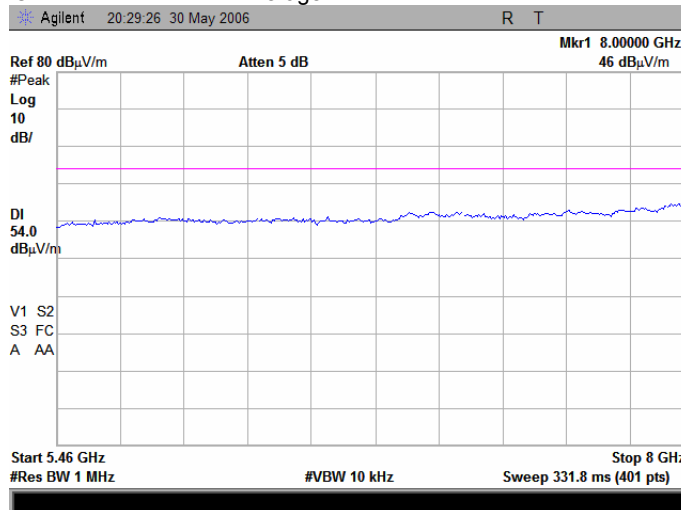

Test specification: Section 15.247(c), Radiated spurious emissions			
Test procedure: FR Vol. 62, page 26243, Section 15.247(c) / ANSI C63.4, Section 13.1.4			
Test mode: Compliance	Verdict: PASS		
Date & Time: 6/6/2006 1:35:17 PM			
Temperature: 23 °C	Air Pressure: 1013 hPa	Relative Humidity: 48 %	Power Supply: 120 VAC
Remarks:			

Plot 7.5.45 Radiated emission measurements from 8.0 to 14.0 GHz at the low carrier frequency

TEST SITE: Anechoic chamber
 TEST DISTANCE: 3 m
 ANTENNA POLARIZATION: Vertical and Horizontal
 INPUTS: 802.11 b/g + 802.11 a
 DETECTOR: Peak

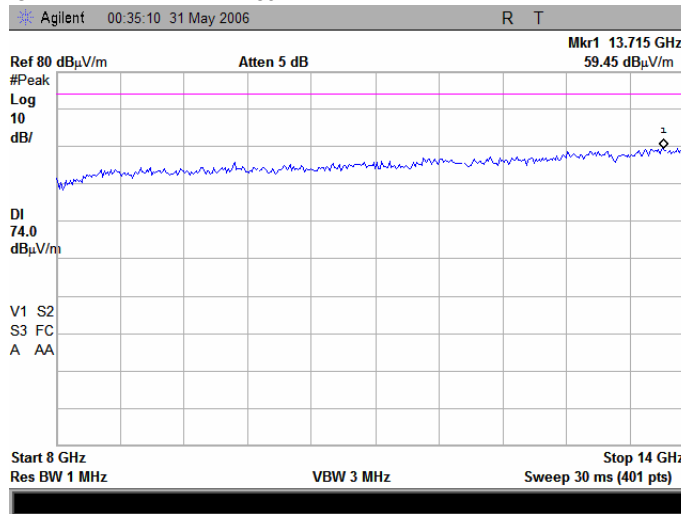

Plot 7.5.46 Radiated emission measurements from 8.0 to 14.0 GHz at the low carrier frequency

TEST SITE: Anechoic chamber
 TEST DISTANCE: 3 m
 ANTENNA POLARIZATION: Vertical and Horizontal
 INPUTS: 802.11 b/g + 802.11 a
 DETECTOR: Average

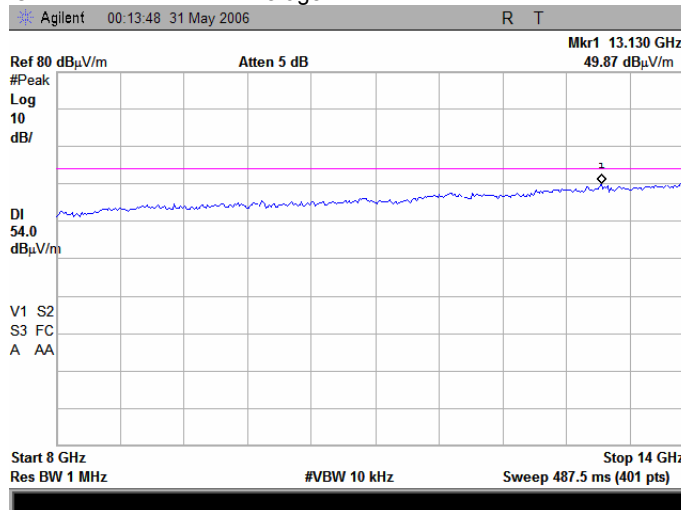

Test specification: Section 15.247(c), Radiated spurious emissions			
Test procedure: FR Vol. 62, page 26243, Section 15.247(c) / ANSI C63.4, Section 13.1.4			
Test mode: Compliance	Verdict: PASS		
Date & Time: 6/6/2006 1:35:17 PM			
Temperature: 23 °C	Air Pressure: 1013 hPa	Relative Humidity: 48 %	Power Supply: 120 VAC
Remarks:			

Plot 7.5.47 Radiated emission measurements from 8.0 to 14.0 GHz at the mid carrier frequency

TEST SITE: Anechoic chamber
 TEST DISTANCE: 3 m
 ANTENNA POLARIZATION: Vertical and Horizontal
 INPUTS: 802.11 b/g + 802.11 a
 DETECTOR: Peak

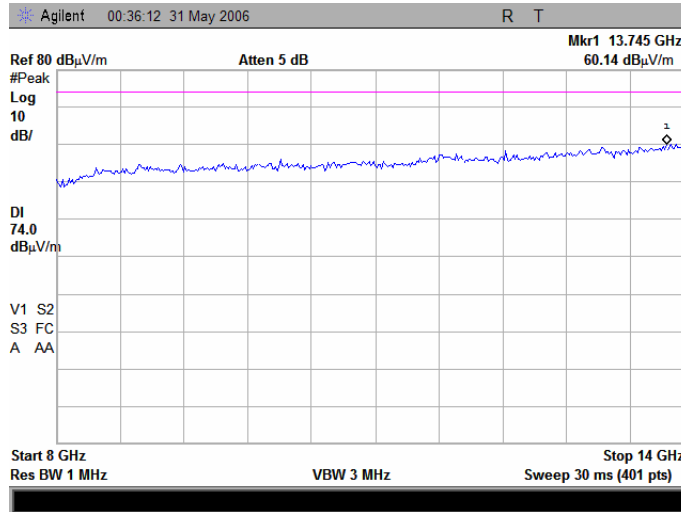

Plot 7.5.48 Radiated emission measurements from 8.0 to 14.0 GHz at the mid carrier frequency

TEST SITE: Anechoic chamber
 TEST DISTANCE: 3 m
 ANTENNA POLARIZATION: Vertical and Horizontal
 INPUTS: 802.11 b/g + 802.11 a
 DETECTOR: Average

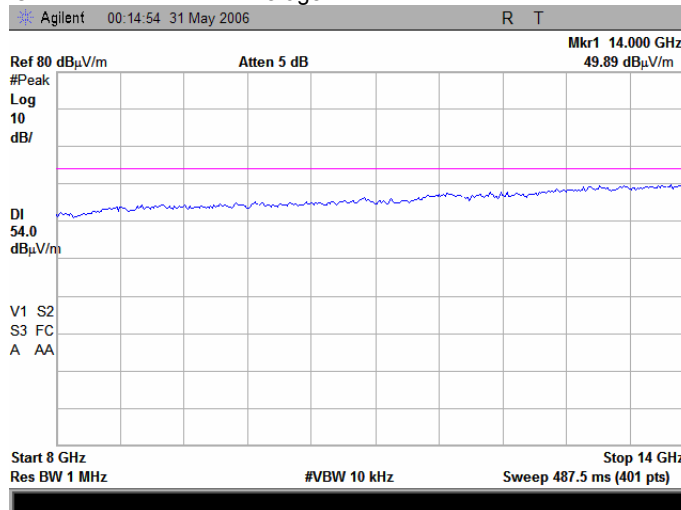

Test specification: Section 15.247(c), Radiated spurious emissions			
Test procedure: FR Vol. 62, page 26243, Section 15.247(c) / ANSI C63.4, Section 13.1.4			
Test mode: Compliance	Verdict: PASS		
Date & Time: 6/6/2006 1:35:17 PM			
Temperature: 23 °C	Air Pressure: 1013 hPa	Relative Humidity: 48 %	Power Supply: 120 VAC
Remarks:			

Plot 7.5.49 Radiated emission measurements from 8.0 to 14.0 GHz at the high carrier frequency

TEST SITE: Anechoic chamber
 TEST DISTANCE: 3 m
 ANTENNA POLARIZATION: Vertical and Horizontal
 INPUTS: 802.11 b/g + 802.11 a
 DETECTOR: Peak

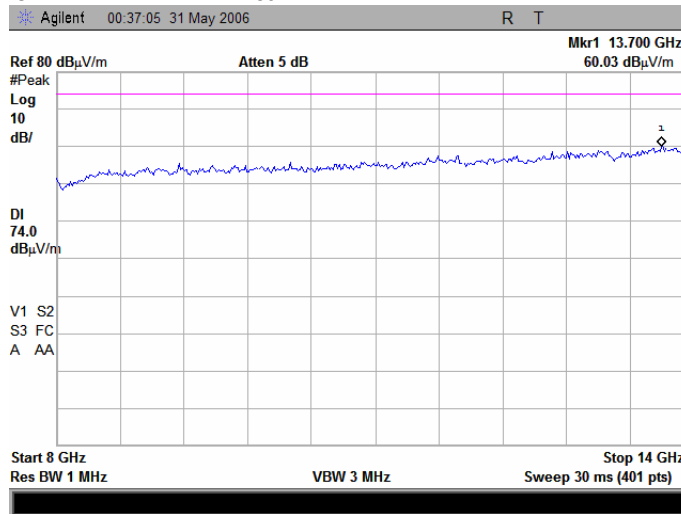

Plot 7.5.50 Radiated emission measurements from 8.0 to 14.0 GHz at the high carrier frequency

TEST SITE: Anechoic chamber
 TEST DISTANCE: 3 m
 ANTENNA POLARIZATION: Vertical and Horizontal
 INPUTS: 802.11 b/g + 802.11 a
 DETECTOR: Average

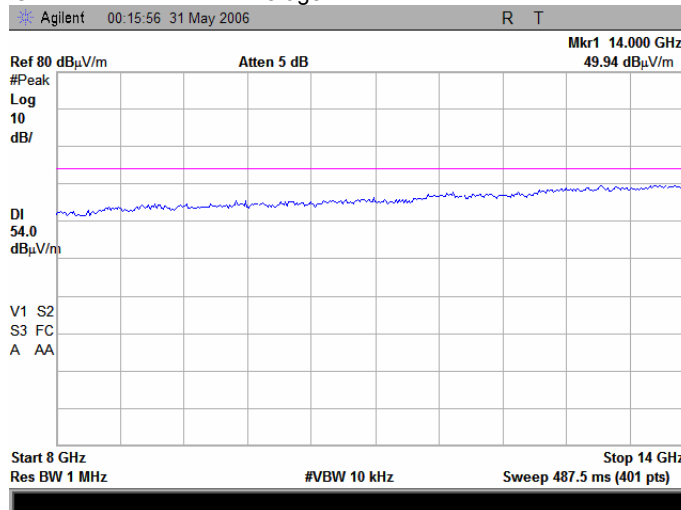

Test specification:	Section 15.247(c), Radiated spurious emissions		
Test procedure:	FR Vol. 62, page 26243, Section 15.247(c) / ANSI C63.4, Section 13.1.4		
Test mode:	Compliance	Verdict: PASS	
Date & Time:	6/6/2006 1:35:17 PM		
Temperature: 23 °C	Air Pressure: 1013 hPa	Relative Humidity: 48 %	Power Supply: 120 VAC
Remarks:			

Plot 7.5.51 Radiated emission measurements from 14.0 to 18.0 GHz at the low carrier frequency

TEST SITE: OATS
 TEST DISTANCE: 3 m
 ANTENNA POLARIZATION: Vertical and Horizontal
 INPUTS: 802.11 b/g + 802.11 a
 DETECTOR: Peak

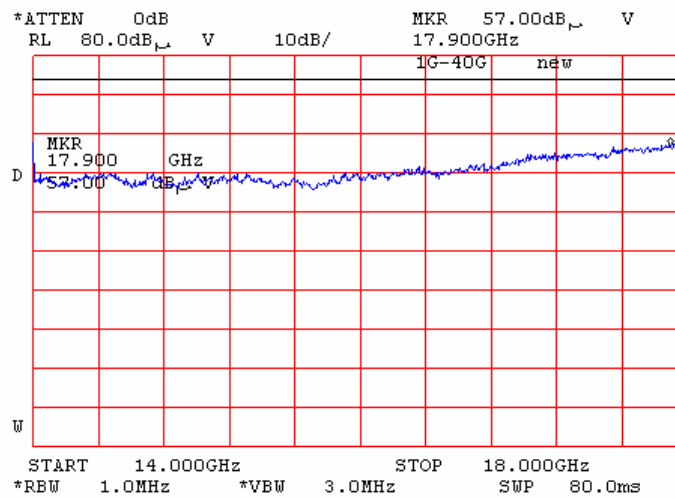

Plot 7.5.52 Radiated emission measurements from 14.0 to 18.0 GHz at the low carrier frequency

TEST SITE: OATS
 TEST DISTANCE: 3 m
 ANTENNA POLARIZATION: Vertical and Horizontal
 INPUTS: 802.11 b/g + 802.11 a
 DETECTOR: average

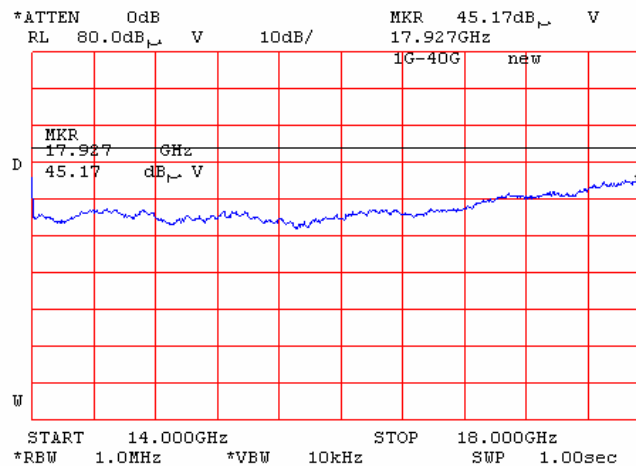

Test specification:	Section 15.247(c), Radiated spurious emissions		
Test procedure:	FR Vol. 62, page 26243, Section 15.247(c) / ANSI C63.4, Section 13.1.4		
Test mode:	Compliance	Verdict:	PASS
Date & Time:	6/6/2006 1:35:17 PM		
Temperature: 23 °C	Air Pressure: 1013 hPa	Relative Humidity: 48 %	Power Supply: 120 VAC
Remarks:			

Plot 7.5.53 Radiated emission measurements from 14.0 to 18.0 GHz at the mid carrier frequency

TEST SITE: OATS
 TEST DISTANCE: 3 m
 ANTENNA POLARIZATION: Vertical and Horizontal
 INPUTS: 802.11 b/g + 802.11 a
 DETECTOR: Peak

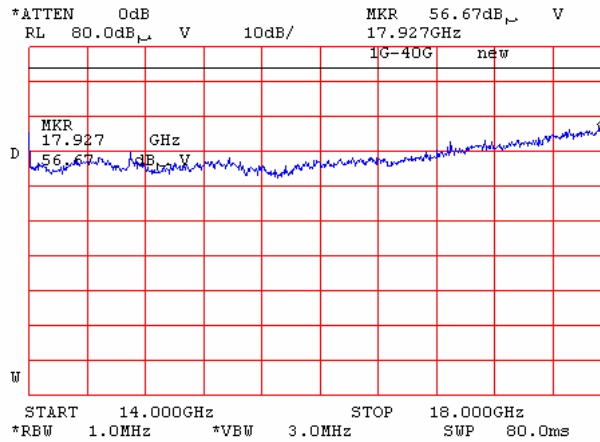

Plot 7.5.54 Radiated emission measurements from 14.0 to 18.0 GHz at the mid carrier frequency

TEST SITE: OATS
 TEST DISTANCE: 3 m
 ANTENNA POLARIZATION: Vertical and Horizontal
 INPUTS: 802.11 b/g + 802.11 a
 DETECTOR: average

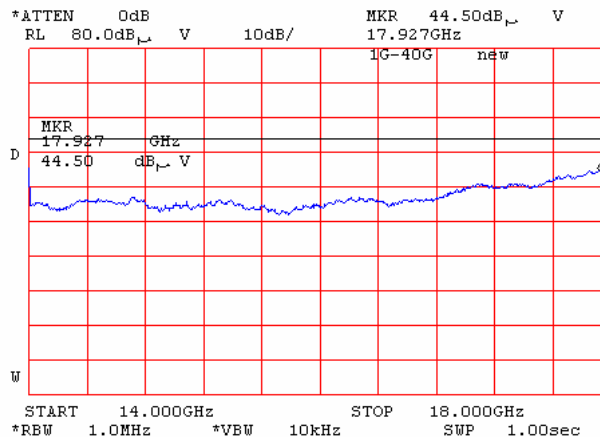

Test specification:	Section 15.247(c), Radiated spurious emissions		
Test procedure:	FR Vol. 62, page 26243, Section 15.247(c) / ANSI C63.4, Section 13.1.4		
Test mode:	Compliance	Verdict:	PASS
Date & Time:	6/6/2006 1:35:17 PM		
Temperature: 23 °C	Air Pressure: 1013 hPa	Relative Humidity: 48 %	Power Supply: 120 VAC
Remarks:			

Plot 7.5.55 Radiated emission measurements from 14.0 to 18.0 GHz at the high carrier frequency

TEST SITE: OATS
 TEST DISTANCE: 3 m
 ANTENNA POLARIZATION: Vertical and Horizontal
 INPUTS: 802.11 b/g + 802.11 a
 DETECTOR: Peak

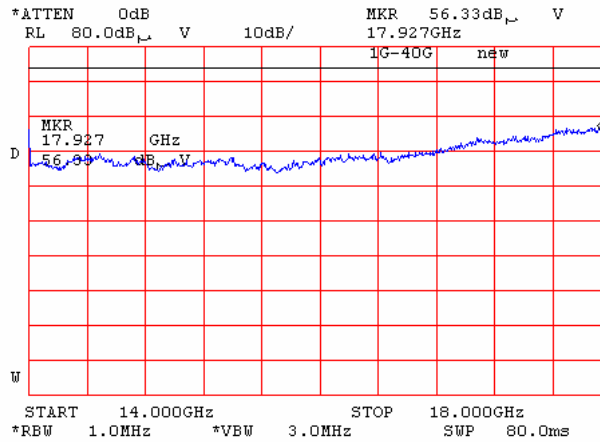

Plot 7.5.56 Radiated emission measurements from 14.0 to 18.0 GHz at the high carrier frequency

TEST SITE: OATS
 TEST DISTANCE: 3 m
 ANTENNA POLARIZATION: Vertical and Horizontal
 INPUTS: 802.11 b/g + 802.11 a
 DETECTOR: average

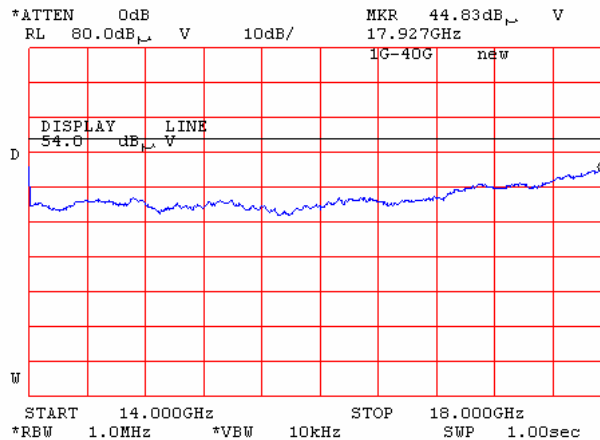

Test specification:	Section 15.247(c), Radiated spurious emissions		
Test procedure:	FR Vol. 62, page 26243, Section 15.247(c) / ANSI C63.4, Section 13.1.4		
Test mode:	Compliance	Verdict:	PASS
Date & Time:	6/6/2006 1:35:17 PM		
Temperature: 23 °C	Air Pressure: 1013 hPa	Relative Humidity: 48 %	Power Supply: 120 VAC
Remarks:			

Plot 7.5.57 Radiated emission measurements from 18.0 to 26.5 GHz at the low carrier frequency

TEST SITE: OATS
 TEST DISTANCE: 3 m
 ANTENNA POLARIZATION: Vertical and Horizontal
 INPUTS: 802.11 b/g + 802.11 a
 DETECTOR: Peak

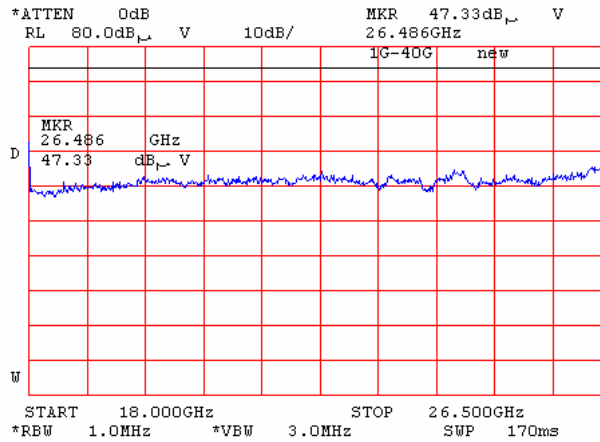

Plot 7.5.58 Radiated emission measurements from 18.0 to 26.5 GHz at the mid carrier frequency

TEST SITE: OATS
 TEST DISTANCE: 3 m
 ANTENNA POLARIZATION: Vertical and Horizontal
 INPUTS: 802.11 b/g + 802.11 a
 DETECTOR: Peak

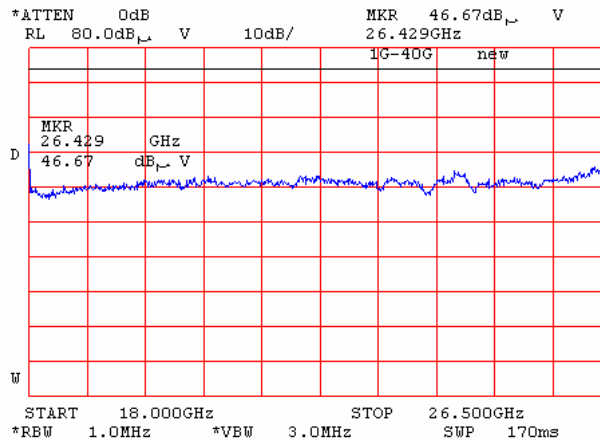

Test specification:	Section 15.247(c), Radiated spurious emissions		
Test procedure:	FR Vol. 62, page 26243, Section 15.247(c) / ANSI C63.4, Section 13.1.4		
Test mode:	Compliance	Verdict:	PASS
Date & Time:	6/6/2006 1:35:17 PM		
Temperature: 23 °C	Air Pressure: 1013 hPa	Relative Humidity: 48 %	Power Supply: 120 VAC
Remarks:			

Plot 7.5.59 Radiated emission measurements from 18.0 to 26.5 GHz at the high carrier frequency

TEST SITE: OATS
 TEST DISTANCE: 3 m
 ANTENNA POLARIZATION: Vertical and Horizontal
 INPUTS: 802.11 b/g + 802.11 a
 DETECTOR: Peak

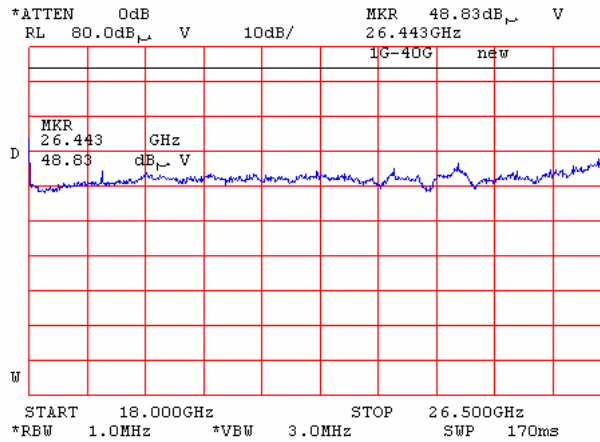

Test specification:	Section 15.247(c), Radiated spurious emissions		
Test procedure:	FR Vol. 62, page 26243, Section 15.247(c) / ANSI C63.4, Section 13.1.4		
Test mode:	Compliance	Verdict: PASS	
Date & Time:	6/6/2006 1:35:17 PM		
Temperature: 23 °C	Air Pressure: 1013 hPa	Relative Humidity: 48 %	Power Supply: 120 VAC
Remarks:			

Plot 7.5.60 Radiated emission measurements at the second harmonic of low carrier frequency

TEST SITE: OATS
TEST DISTANCE: 3 m

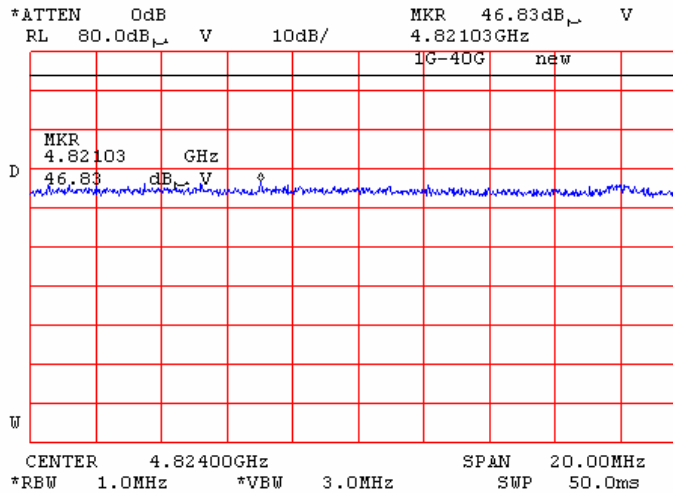

Plot 7.5.61 Radiated emission measurements at the second harmonic of mid carrier frequency

TEST SITE: OATS
TEST DISTANCE: 3 m

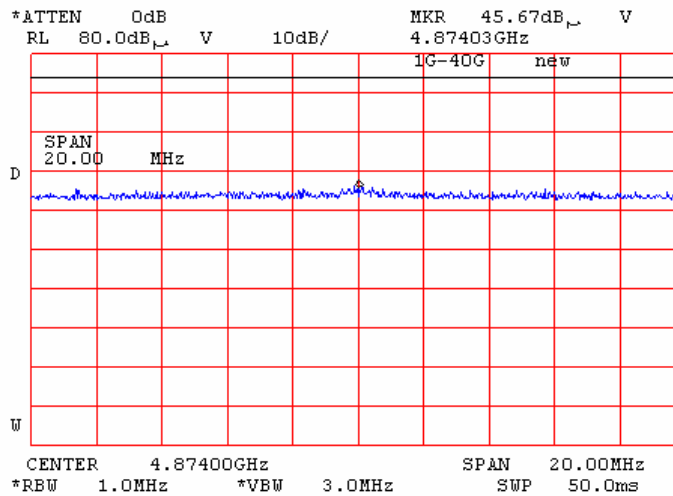

Test specification:	Section 15.247(c), Radiated spurious emissions		
Test procedure:	FR Vol. 62, page 26243, Section 15.247(c) / ANSI C63.4, Section 13.1.4		
Test mode:	Compliance	Verdict:	PASS
Date & Time:	6/6/2006 1:35:17 PM		
Temperature: 23 °C	Air Pressure: 1013 hPa	Relative Humidity: 48 %	Power Supply: 120 VAC
Remarks:			

Plot 7.5.62 Radiated emission measurements at the second harmonic of high carrier frequency

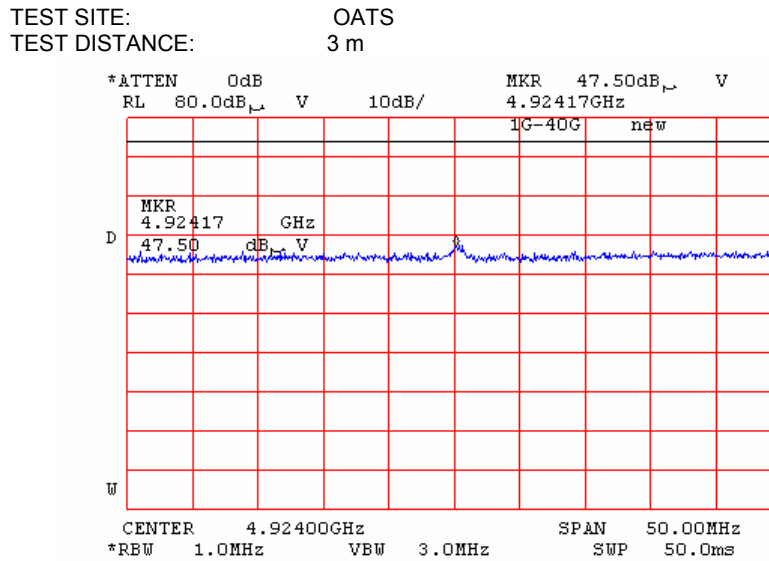

Plot 7.5.63 Radiated emission measurements at the third harmonic of low carrier frequency

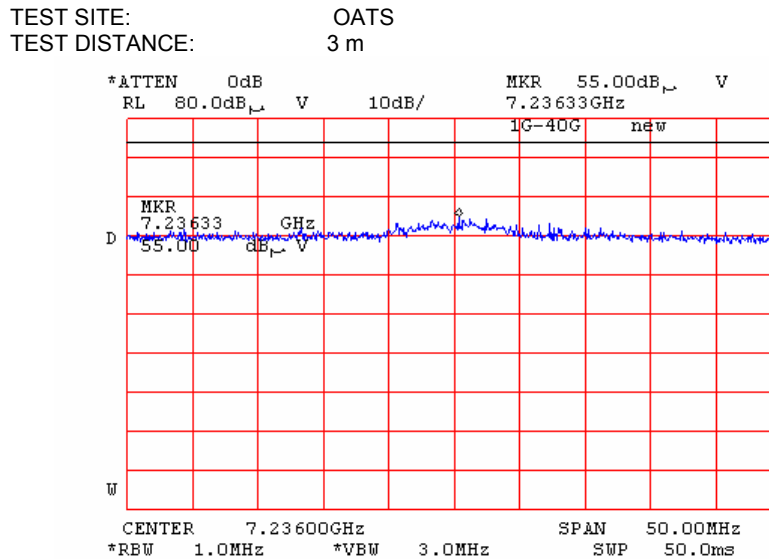

Test specification: Section 15.247(c), Radiated spurious emissions			
Test procedure: FR Vol. 62, page 26243, Section 15.247(c) / ANSI C63.4, Section 13.1.4			
Test mode: Compliance	Verdict: PASS		
Date & Time: 6/6/2006 1:35:17 PM			
Temperature: 23 °C	Air Pressure: 1013 hPa	Relative Humidity: 48 %	Power Supply: 120 VAC
Remarks:			

Plot 7.5.64 Radiated emission measurements at the third harmonic of mid carrier frequency

TEST SITE: OATS
TEST DISTANCE: 3 m
DETECTOR: peak

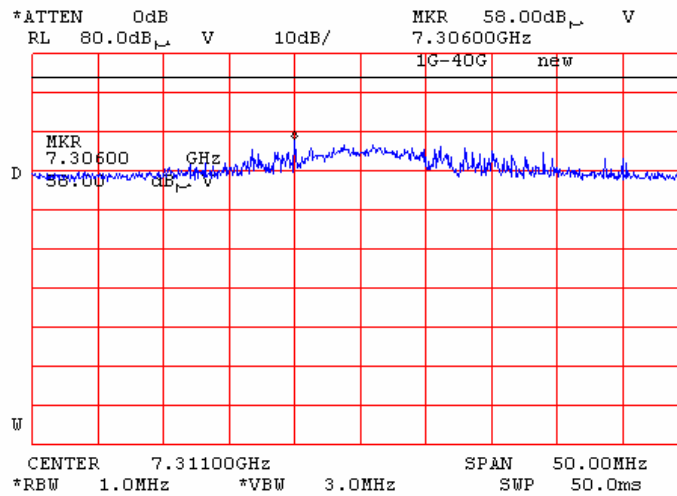

Plot 7.5.65 Radiated emission measurements at the third harmonic of mid carrier frequency

TEST SITE: OATS
TEST DISTANCE: 3 m
DETECTOR: average

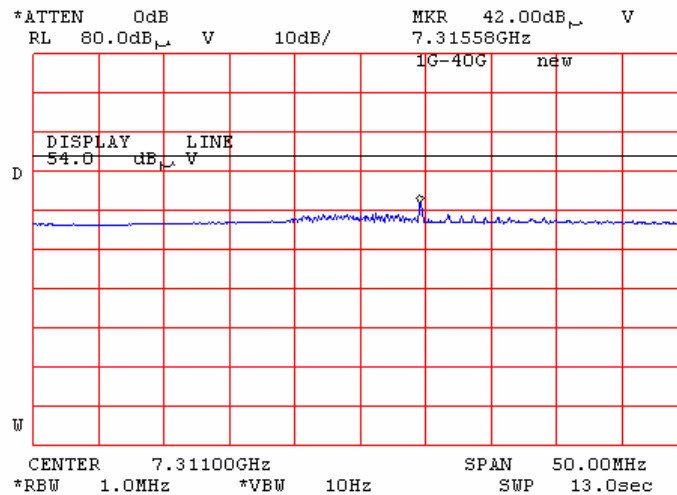

Test specification:	Section 15.247(c), Radiated spurious emissions		
Test procedure:	FR Vol. 62, page 26243, Section 15.247(c) / ANSI C63.4, Section 13.1.4		
Test mode:	Compliance	Verdict:	PASS
Date & Time:	6/6/2006 1:35:17 PM		
Temperature: 23 °C	Air Pressure: 1013 hPa	Relative Humidity: 48 %	Power Supply: 120 VAC
Remarks:			

Plot 7.5.66 Radiated emission measurements at the third harmonic of high carrier frequency

TEST SITE: OATS
TEST DISTANCE: 3 m
DETECTOR: peak

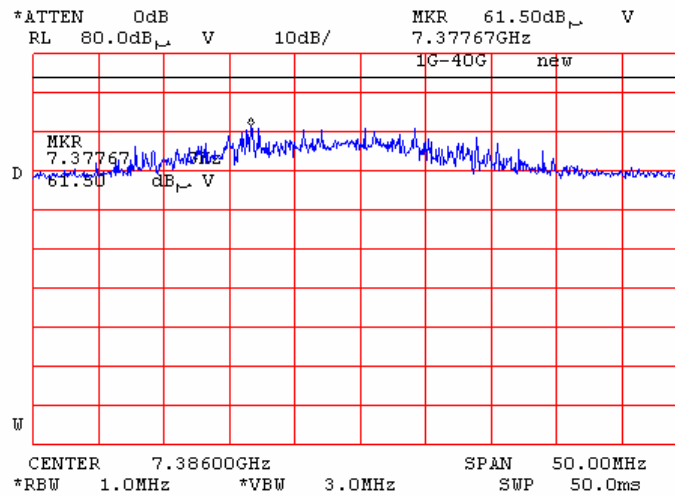

Plot 7.5.67 Radiated emission measurements at the third harmonic of high carrier frequency

TEST SITE: OATS
TEST DISTANCE: 3 m
DETECTOR: average

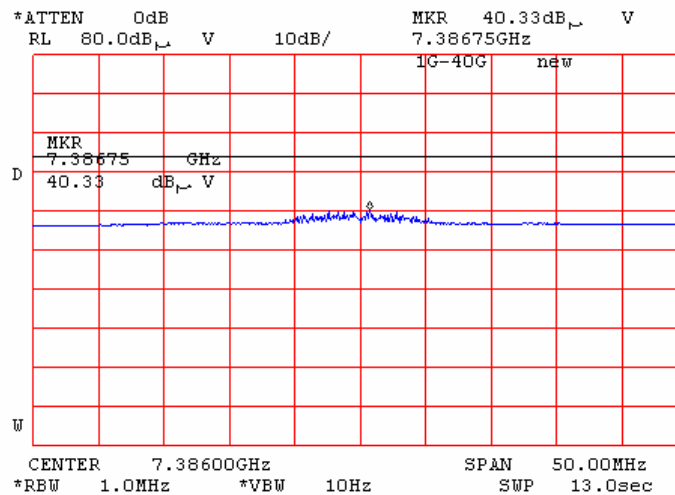

Test specification:	Section 15.247(c), Radiated spurious emissions		
Test procedure:	FR Vol. 62, page 26243, Section 15.247(c) / ANSI C63.4, Section 13.1.4		
Test mode:	Compliance	Verdict: PASS	
Date & Time:	6/6/2006 1:35:17 PM		
Temperature: 23 °C	Air Pressure: 1013 hPa	Relative Humidity: 48 %	Power Supply: 120 VAC
Remarks:			

Plot 7.5.68 Radiated emission measurements at the fourth harmonic of low carrier frequency

TEST SITE: OATS
TEST DISTANCE: 3 m

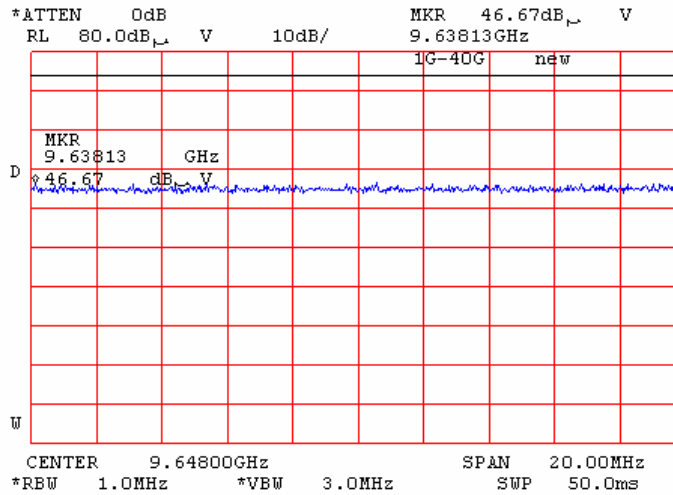

Plot 7.5.69 Radiated emission measurements at the fourth harmonic of mid carrier frequency

TEST SITE: OATS
TEST DISTANCE: 3 m

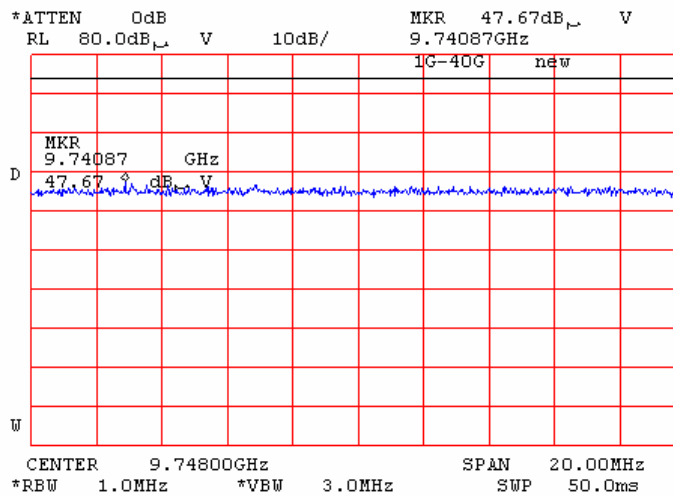

Test specification:	Section 15.247(c), Radiated spurious emissions		
Test procedure:	FR Vol. 62, page 26243, Section 15.247(c) / ANSI C63.4, Section 13.1.4		
Test mode:	Compliance	Verdict: PASS	
Date & Time:	6/6/2006 1:35:17 PM		
Temperature: 23 °C	Air Pressure: 1013 hPa	Relative Humidity: 48 %	Power Supply: 120 VAC
Remarks:			

Plot 7.5.70 Radiated emission measurements at the fourth harmonic of high carrier frequency

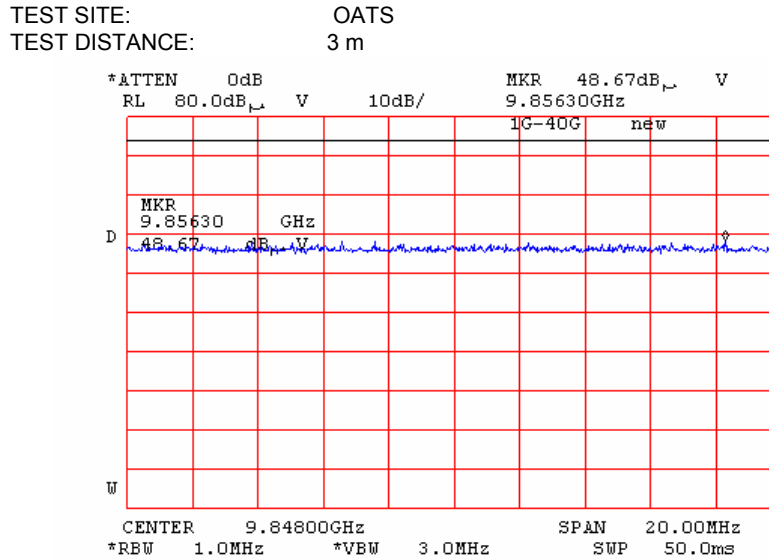

Plot 7.5.71 Transmission pulse duration

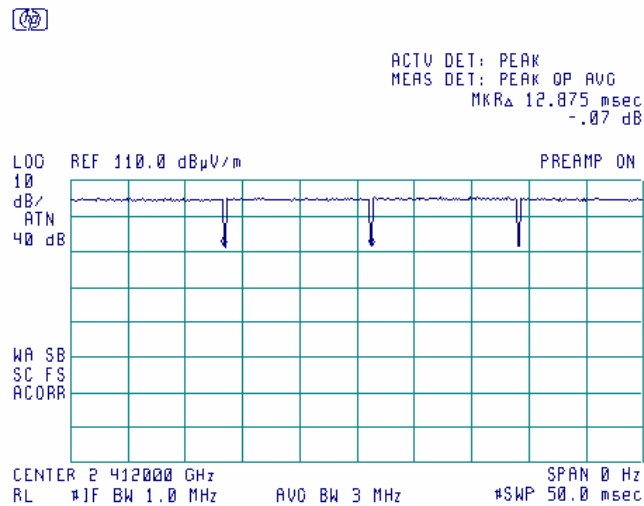

Test specification:	Section 15.247(c), Radiated spurious emissions		
Test procedure:	FR Vol. 62, page 26243, Section 15.247(c) / ANSI C63.4, Section 13.1.4		
Test mode:	Compliance	Verdict:	PASS
Date & Time:	6/6/2006 1:35:17 PM		
Temperature: 23 °C	Air Pressure: 1013 hPa	Relative Humidity: 48 %	Power Supply: 120 VAC
Remarks:			

Plot 7.5.72 Radiated emission measurements from 9 to 150 kHz at the low carrier frequency

TEST SITE: Anechoic chamber
 TEST DISTANCE: 3 m
 ANTENNA POLARIZATION: Vertical
 INPUTS: 802.11 b/g + 802.11 a + licensed

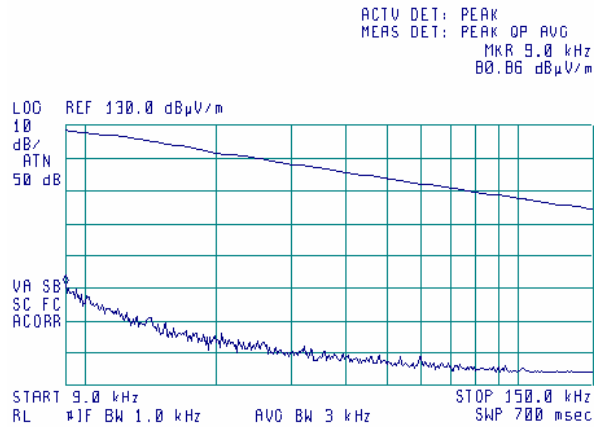

Plot 7.5.73 Radiated emission measurements from 9 to 150 kHz at the mid carrier frequency

TEST SITE: Anechoic chamber
 TEST DISTANCE: 3 m
 ANTENNA POLARIZATION: Vertical
 INPUTS: 802.11 b/g + 802.11 a + licensed

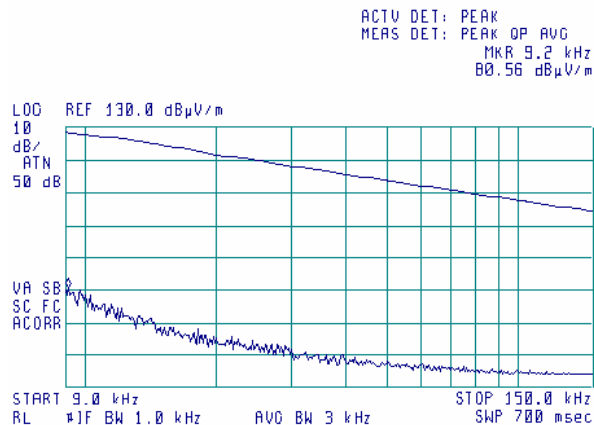

Test specification:	Section 15.247(c), Radiated spurious emissions		
Test procedure:	FR Vol. 62, page 26243, Section 15.247(c) / ANSI C63.4, Section 13.1.4		
Test mode:	Compliance	Verdict:	PASS
Date & Time:	6/6/2006 1:35:17 PM		
Temperature: 23 °C	Air Pressure: 1013 hPa	Relative Humidity: 48 %	Power Supply: 120 VAC
Remarks:			

Plot 7.5.74 Radiated emission measurements from 9 to 150 kHz at the high carrier frequency

TEST SITE: Anechoic chamber
 TEST DISTANCE: 3 m
 ANTENNA POLARIZATION: Vertical
 INPUTS: 802.11 b/g + 802.11 a + licensed

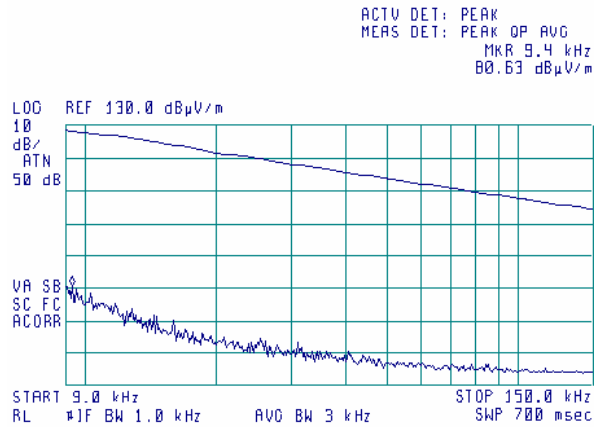

Plot 7.5.75 Radiated emission measurements from 0.15 to 30 MHz at the low carrier frequency

TEST SITE: Anechoic chamber
 TEST DISTANCE: 3 m
 ANTENNA POLARIZATION: Vertical
 INPUTS: 802.11 b/g + 802.11 a + licensed

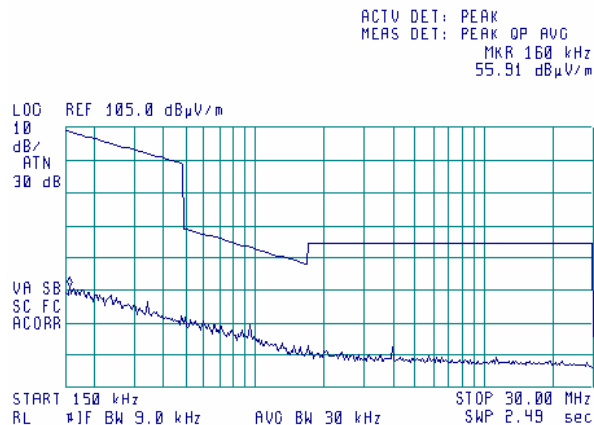

Test specification: Section 15.247(c), Radiated spurious emissions			
Test procedure: FR Vol. 62, page 26243, Section 15.247(c) / ANSI C63.4, Section 13.1.4			
Test mode: Compliance	Verdict: PASS		
Date & Time: 6/6/2006 1:35:17 PM			
Temperature: 23 °C	Air Pressure: 1013 hPa	Relative Humidity: 48 %	Power Supply: 120 VAC
Remarks:			

Plot 7.5.76 Radiated emission measurements from 0.15 to 30 MHz at the mid carrier frequency

TEST SITE: Anechoic chamber
 TEST DISTANCE: 3 m
 ANTENNA POLARIZATION: Vertical
 INPUTS: 802.11 b/g + 802.11 a + licensed

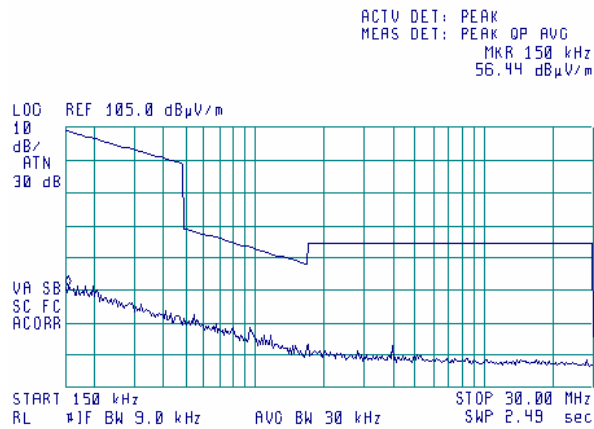

Plot 7.5.77 Radiated emission measurements from 0.15 to 30 MHz at the high carrier frequency

TEST SITE: Anechoic chamber
 TEST DISTANCE: 3 m
 ANTENNA POLARIZATION: Vertical
 INPUTS: 802.11 b/g + 802.11 a + licensed

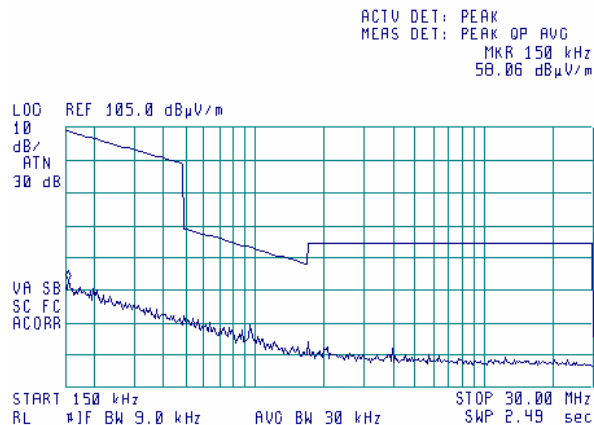

Test specification: Section 15.247(c), Radiated spurious emissions			
Test procedure: FR Vol. 62, page 26243, Section 15.247(c) / ANSI C63.4, Section 13.1.4			
Test mode: Compliance	Verdict: PASS		
Date & Time: 6/6/2006 1:35:17 PM			
Temperature: 23 °C	Air Pressure: 1013 hPa	Relative Humidity: 48 %	Power Supply: 120 VAC
Remarks:			

Plot 7.5.78 Radiated emission measurements from 30 to 1000 MHz at the low carrier frequency

TEST SITE: Anechoic chamber
 TEST DISTANCE: 3 m
 ANTENNA POLARIZATION: Vertical and Horizontal
 INPUTS: 802.11 b/g + 802.11 a + licensed

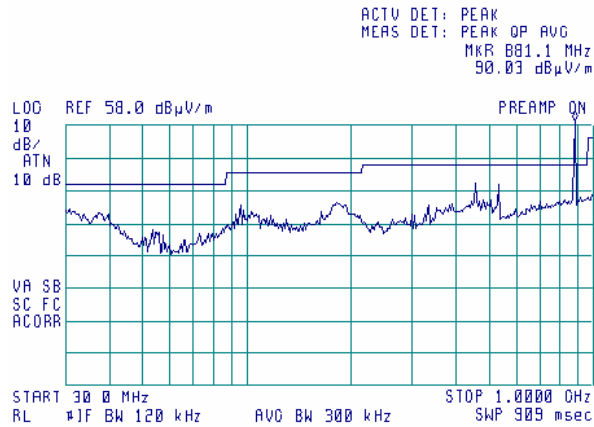

Plot 7.5.79 Radiated emission measurements from 30 to 1000 MHz at the mid carrier frequency

TEST SITE: Anechoic chamber
 TEST DISTANCE: 3 m
 ANTENNA POLARIZATION: Vertical and Horizontal
 INPUTS: 802.11 b/g + 802.11 a + licensed

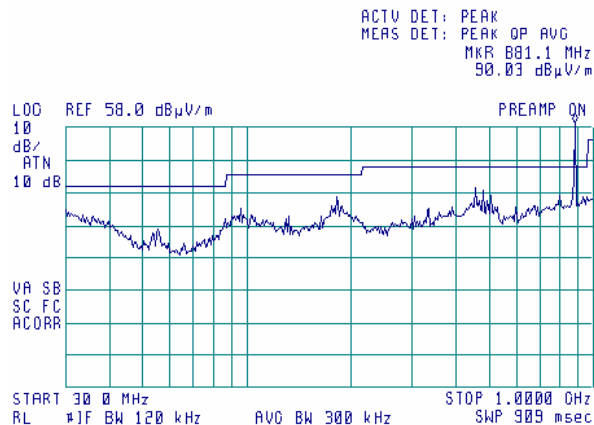

Test specification:	Section 15.247(c), Radiated spurious emissions		
Test procedure:	FR Vol. 62, page 26243, Section 15.247(c) / ANSI C63.4, Section 13.1.4		
Test mode:	Compliance	Verdict:	PASS
Date & Time:	6/6/2006 1:35:17 PM		
Temperature: 23 °C	Air Pressure: 1013 hPa	Relative Humidity: 48 %	Power Supply: 120 VAC
Remarks:			

Plot 7.5.80 Radiated emission measurements from 30 to 1000 MHz at the high carrier frequency

TEST SITE: Anechoic chamber
 TEST DISTANCE: 3 m
 ANTENNA POLARIZATION: Vertical and Horizontal
 INPUTS: 802.11 b/g + 802.11 a + licensed

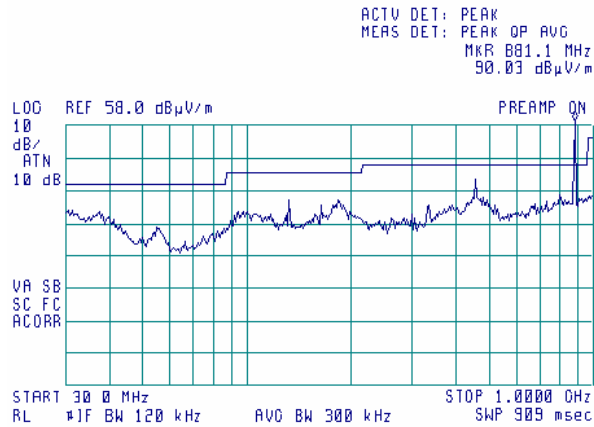

Test specification:	Section 15.247(c), Radiated spurious emissions		
Test procedure:	FR Vol. 62, page 26243, Section 15.247(c) / ANSI C63.4, Section 13.1.4		
Test mode:	Compliance	Verdict:	PASS
Date & Time:	6/6/2006 1:35:17 PM		
Temperature: 23 °C	Air Pressure: 1013 hPa	Relative Humidity: 48 %	Power Supply: 120 VAC
Remarks:			

Plot 7.5.81 Radiated emission measurements from 1000 to 2350 MHz at the low carrier frequency

TEST SITE: Anechoic chamber
 TEST DISTANCE: 3 m
 ANTENNA POLARIZATION: Vertical and Horizontal
 INPUTS: 802.11 b/g + 802.11 a + licensed
 DETECTOR: Peak

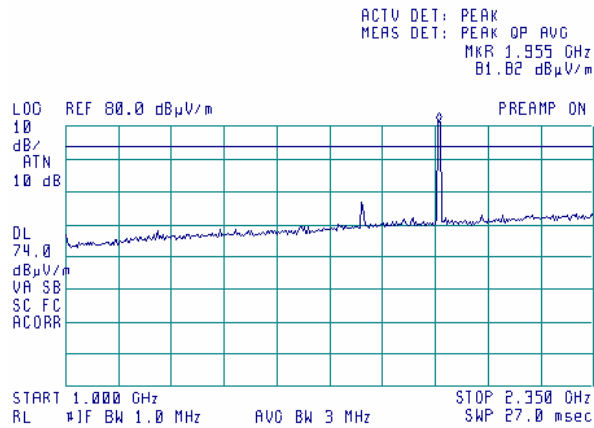

Plot 7.5.82 Radiated emission measurements from 1000 to 2350 MHz at the low carrier frequency

TEST SITE: Anechoic chamber
 TEST DISTANCE: 3 m
 ANTENNA POLARIZATION: Vertical and Horizontal
 INPUTS: 802.11 b/g + 802.11 a + licensed
 DETECTOR: Average

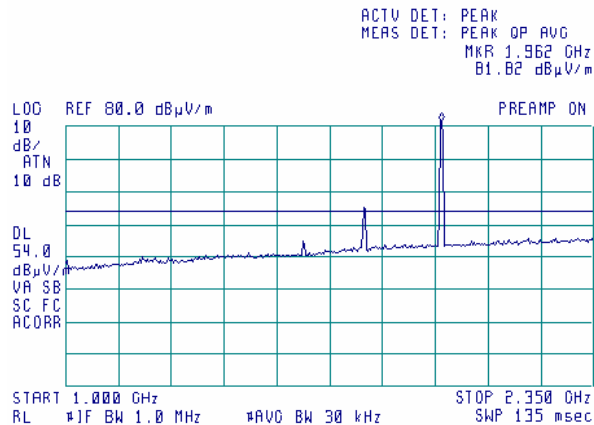

Note: 1655 MHz is outside restricted band emission, not tested radiated

Test specification: Section 15.247(c), Radiated spurious emissions			
Test procedure: FR Vol. 62, page 26243, Section 15.247(c) / ANSI C63.4, Section 13.1.4			
Test mode: Compliance	Verdict: PASS		
Date & Time: 6/6/2006 1:35:17 PM			
Temperature: 23 °C	Air Pressure: 1013 hPa	Relative Humidity: 48 %	Power Supply: 120 VAC
Remarks:			

Plot 7.5.83 Radiated emission measurements from 2350 to 2390 MHz at the low carrier frequency

TEST SITE: Anechoic chamber
 TEST DISTANCE: 3 m
 ANTENNA POLARIZATION: Vertical and Horizontal
 INPUTS: 802.11 b/g + 802.11 a + licensed
 DETECTOR: Peak

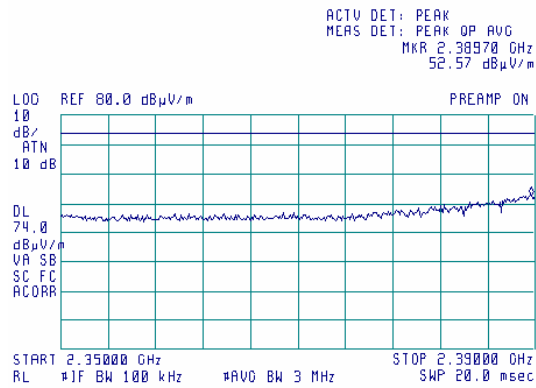

Note: Signal field strength = SA reading + BW factor = 52.57 dBµV/m + 10log(1MHz/100kHz) = 52.57 dBµV/m + 10 dB = 62.57 dBµV/m

Plot 7.5.84 Radiated emission measurements from 2350 to 2390 MHz at the low carrier frequency

TEST SITE: Anechoic chamber
 TEST DISTANCE: 3 m
 ANTENNA POLARIZATION: Vertical and Horizontal
 INPUTS: 802.11 b/g + 802.11 a + licensed
 DETECTOR: Average

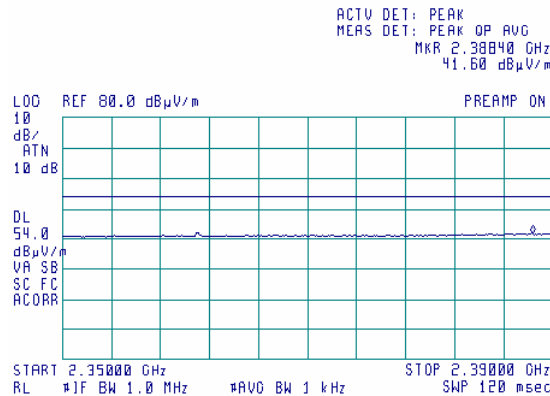

Test specification:	Section 15.247(c), Radiated spurious emissions		
Test procedure:	FR Vol. 62, page 26243, Section 15.247(c) / ANSI C63.4, Section 13.1.4		
Test mode:	Compliance	Verdict: PASS	
Date & Time:	6/6/2006 1:35:17 PM		
Temperature: 23 °C	Air Pressure: 1013 hPa	Relative Humidity: 48 %	Power Supply: 120 VAC
Remarks:			

Plot 7.5.85 Radiated emission measurements from 1000 to 2390 MHz at the mid carrier frequency

TEST SITE: Anechoic chamber
 TEST DISTANCE: 3 m
 ANTENNA POLARIZATION: Vertical and Horizontal
 INPUTS: 802.11 b/g + 802.11 a + licensed
 DETECTOR: Peak

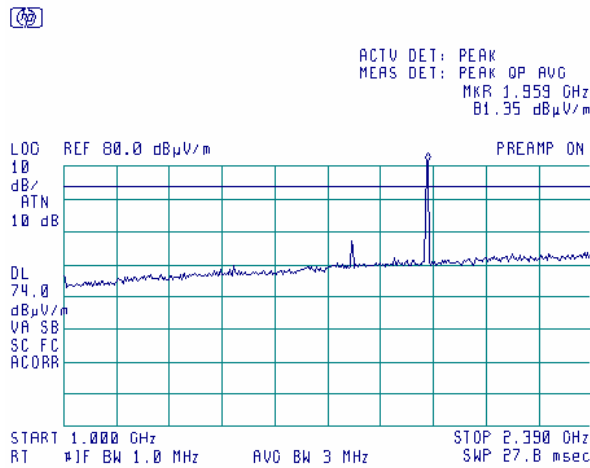

Note: 1960 MHz – intended emission of PCS module, 1763 MHz – second harmonic of CELL module

Plot 7.5.86 Radiated emission measurements from 1000 to 2390 MHz at the mid carrier frequency

TEST SITE: Anechoic chamber
 TEST DISTANCE: 3 m
 ANTENNA POLARIZATION: Vertical and Horizontal
 INPUTS: 802.11 b/g + 802.11 a + licensed
 DETECTOR: Average

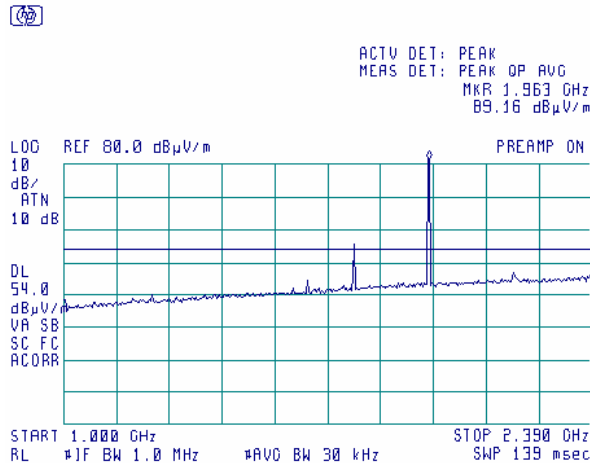

Note: 1655 MHz is outside restricted band emission, not tested radiated

Test specification:	Section 15.247(c), Radiated spurious emissions		
Test procedure:	FR Vol. 62, page 26243, Section 15.247(c) / ANSI C63.4, Section 13.1.4		
Test mode:	Compliance	Verdict:	PASS
Date & Time:	6/6/2006 1:35:17 PM		
Temperature: 23 °C	Air Pressure: 1013 hPa	Relative Humidity: 48 %	Power Supply: 120 VAC
Remarks:			

Plot 7.5.87 Radiated emission measurements from 1000 to 2390 MHz at the high carrier frequency

TEST SITE: Anechoic chamber
 TEST DISTANCE: 3 m
 ANTENNA POLARIZATION: Vertical and Horizontal
 INPUTS: 802.11 b/g + 802.11 a + licensed
 DETECTOR: Peak

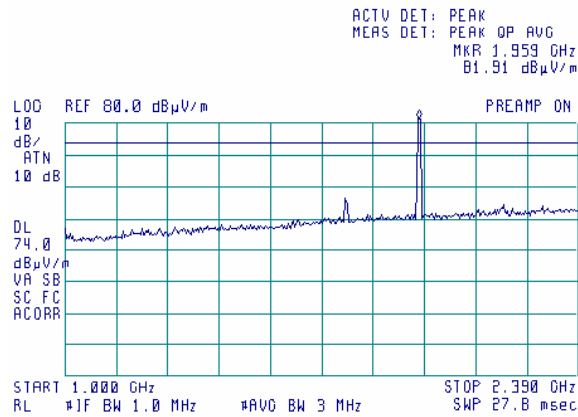

Plot 7.5.88 Radiated emission measurements from 1000 to 2390 MHz at the high carrier frequency

TEST SITE: Anechoic chamber
 TEST DISTANCE: 3 m
 ANTENNA POLARIZATION: Vertical and Horizontal
 INPUTS: 802.11 b/g + 802.11 a + licensed
 DETECTOR: Average

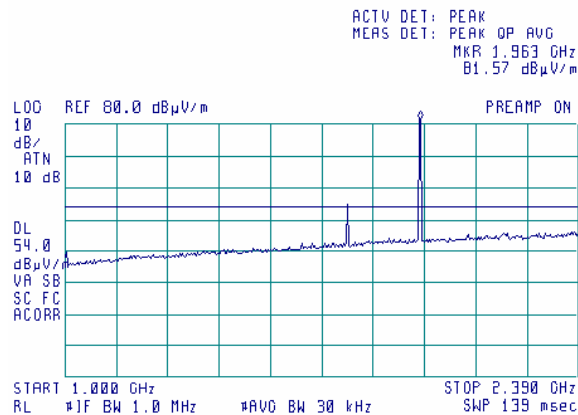

Note: 1655 MHz is outside restricted band emission, not tested radiated

Test specification:		Section 15.247(c), Radiated spurious emissions	
Test procedure:		FR Vol. 62, page 26243, Section 15.247(c) / ANSI C63.4, Section 13.1.4	
Test mode:	Compliance	Verdict:	PASS
Date & Time:	6/6/2006 1:35:17 PM		
Temperature: 23 °C	Air Pressure: 1013 hPa	Relative Humidity: 48 %	Power Supply: 120 VAC
Remarks:			

Plot 7.5.89 Radiated emission measurements from 2483.5 to 2500 MHz at the low carrier frequency

TEST SITE: Anechoic chamber
 TEST DISTANCE: 3 m
 ANTENNA POLARIZATION: Vertical and Horizontal
 INPUTS: 802.11 b/g + 802.11 a + licensed
 DETECTOR: Peak

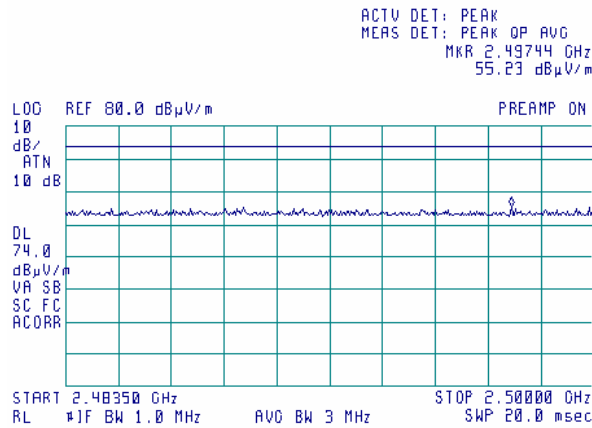

Plot 7.5.90 Radiated emission measurements from 2483.5 to 2500 MHz at the low carrier frequency

TEST SITE: Anechoic chamber
 TEST DISTANCE: 3 m
 ANTENNA POLARIZATION: Vertical and Horizontal
 INPUTS: 802.11 b/g + 802.11 a + licensed
 DETECTOR: Average

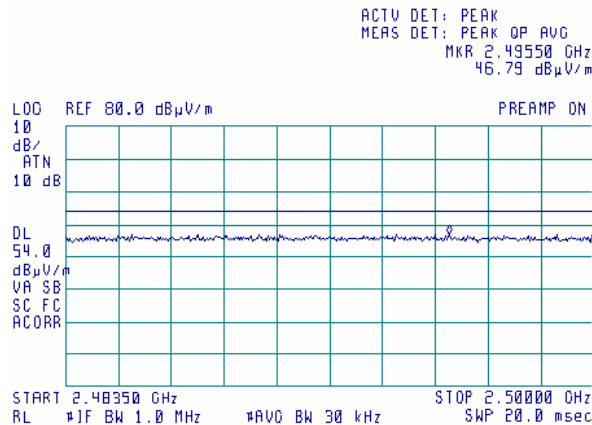

Test specification: Section 15.247(c), Radiated spurious emissions			
Test procedure: FR Vol. 62, page 26243, Section 15.247(c) / ANSI C63.4, Section 13.1.4			
Test mode: Compliance	Verdict: PASS		
Date & Time: 6/6/2006 1:35:17 PM			
Temperature: 23 °C	Air Pressure: 1013 hPa	Relative Humidity: 48 %	Power Supply: 120 VAC
Remarks:			

Plot 7.5.91 Radiated emission measurements from 2483.5 to 2500 MHz at the mid carrier frequency

TEST SITE: Anechoic chamber
 TEST DISTANCE: 3 m
 ANTENNA POLARIZATION: Vertical and Horizontal
 INPUTS: 802.11 b/g + 802.11 a + licensed
 DETECTOR: Peak

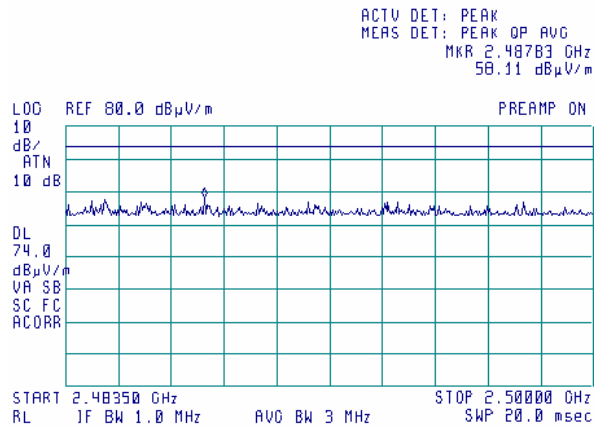

Plot 7.5.92 Radiated emission measurements from 2483.5 to 2500 MHz at the mid carrier frequency

TEST SITE: Anechoic chamber
 TEST DISTANCE: 3 m
 ANTENNA POLARIZATION: Vertical and Horizontal
 INPUTS: 802.11 b/g + 802.11 a + licensed
 DETECTOR: Average

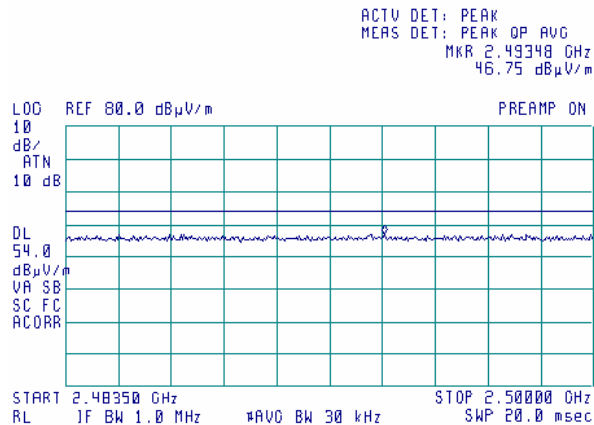

Test specification: Section 15.247(c), Radiated spurious emissions			
Test procedure: FR Vol. 62, page 26243, Section 15.247(c) / ANSI C63.4, Section 13.1.4			
Test mode: Compliance	Verdict: PASS		
Date & Time: 6/6/2006 1:35:17 PM			
Temperature: 23 °C	Air Pressure: 1013 hPa	Relative Humidity: 48 %	Power Supply: 120 VAC
Remarks:			

Plot 7.5.93 Radiated emission measurements from 2483.5 to 2500 MHz at the high carrier frequency

TEST SITE: Anechoic chamber
 TEST DISTANCE: 3 m
 ANTENNA POLARIZATION: Vertical and Horizontal
 INPUTS: 802.11 b/g + 802.11 a + licensed
 DETECTOR: Peak

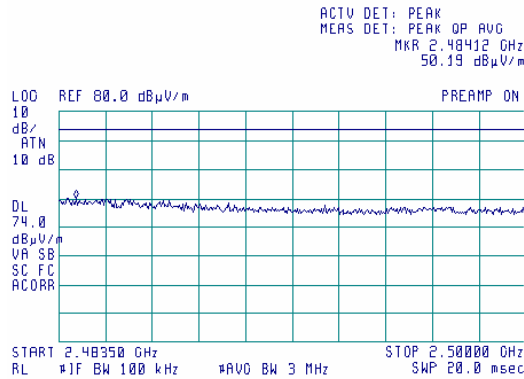

Note: Signal field strength = SA reading + BW factor = 50.19 dBμV/m + 10log(1MHz/100kHz) = 50.19 dBμV/m + 10 dB = 60.19 dBμV/m

Plot 7.5.94 Radiated emission measurements from 2483.5 to 2500 MHz at the high carrier frequency

TEST SITE: Anechoic chamber
 TEST DISTANCE: 3 m
 ANTENNA POLARIZATION: Vertical and Horizontal
 INPUTS: 802.11 b/g + 802.11 a + licensed
 DETECTOR: Average

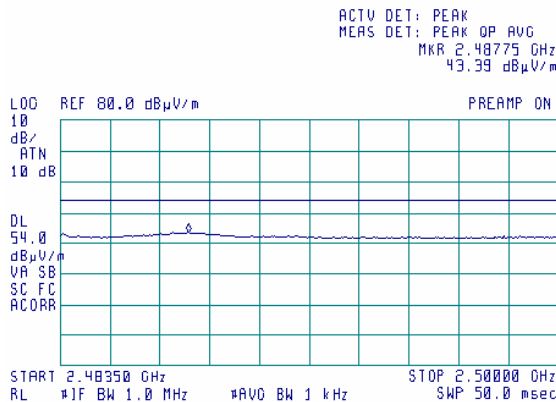

Test specification:		Section 15.247(c), Radiated spurious emissions	
Test procedure: FR Vol. 62, page 26243, Section 15.247(c) / ANSI C63.4, Section 13.1.4			
Test mode: Compliance		Verdict: PASS	
Date & Time: 6/6/2006 1:35:17 PM			
Temperature: 23 °C	Air Pressure: 1013 hPa	Relative Humidity: 48 %	Power Supply: 120 VAC
Remarks:			

Plot 7.5.95 Radiated emission measurements from 2500 to 2900 MHz at the low carrier frequency

TEST SITE: Anechoic chamber
 TEST DISTANCE: 3 m
 ANTENNA POLARIZATION: Vertical and Horizontal
 INPUTS: 802.11 b/g + 802.11 a + licensed
 DETECTOR: Peak

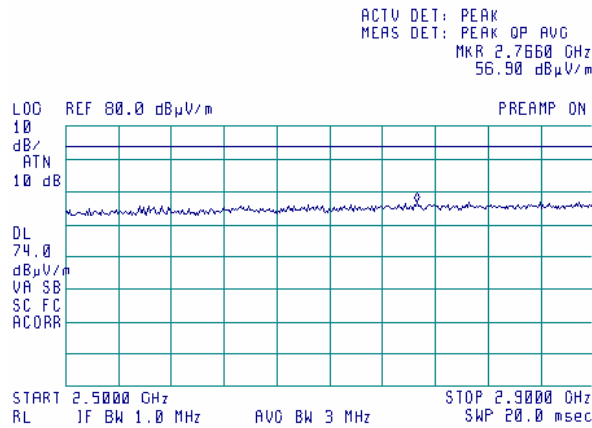

Plot 7.5.96 Radiated emission measurements from 2500 to 2900 MHz at the low carrier frequency

TEST SITE: Anechoic chamber
 TEST DISTANCE: 3 m
 ANTENNA POLARIZATION: Vertical and Horizontal
 INPUTS: 802.11 b/g + 802.11 a + licensed
 DETECTOR: Average

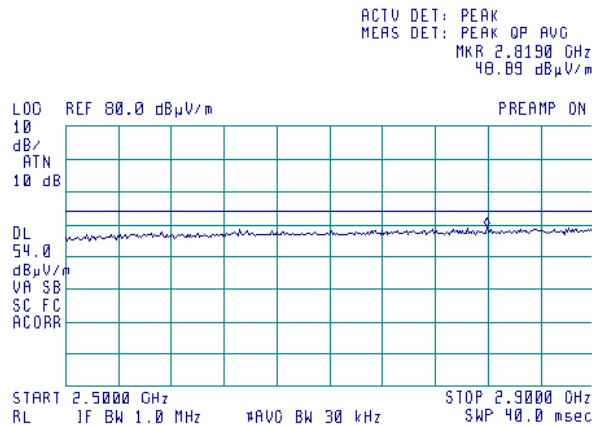

Test specification:	Section 15.247(c), Radiated spurious emissions		
Test procedure:	FR Vol. 62, page 26243, Section 15.247(c) / ANSI C63.4, Section 13.1.4		
Test mode:	Compliance	Verdict:	PASS
Date & Time:	6/6/2006 1:35:17 PM		
Temperature: 23 °C	Air Pressure: 1013 hPa	Relative Humidity: 48 %	Power Supply: 120 VAC
Remarks:			

Plot 7.5.97 Radiated emission measurements from 2500 to 2900 MHz at the mid carrier frequency

TEST SITE: Anechoic chamber
 TEST DISTANCE: 3 m
 ANTENNA POLARIZATION: Vertical and Horizontal
 INPUTS: 802.11 b/g + 802.11 a + licensed
 DETECTOR: Peak

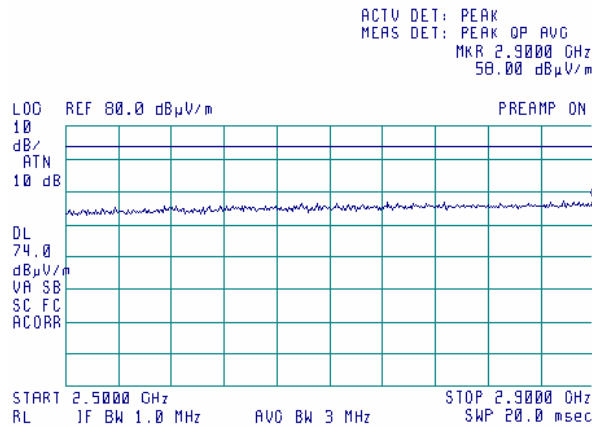

Plot 7.5.98 Radiated emission measurements from 2500 to 2900 MHz at the mid carrier frequency

TEST SITE: Anechoic chamber
 TEST DISTANCE: 3 m
 ANTENNA POLARIZATION: Vertical and Horizontal
 INPUTS: 802.11 b/g + 802.11 a + licensed
 DETECTOR: Average

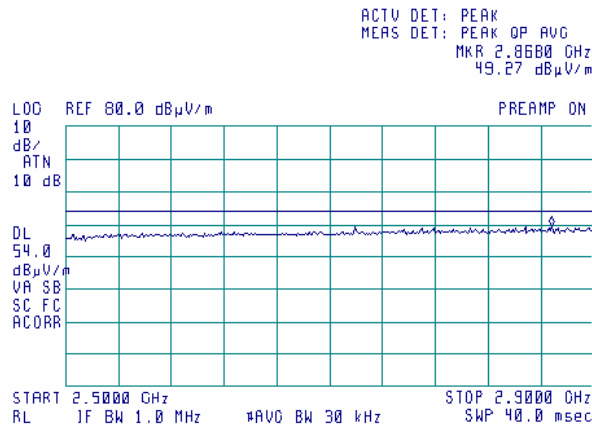

Test specification:	Section 15.247(c), Radiated spurious emissions		
Test procedure:	FR Vol. 62, page 26243, Section 15.247(c) / ANSI C63.4, Section 13.1.4		
Test mode:	Compliance	Verdict:	PASS
Date & Time:	6/6/2006 1:35:17 PM		
Temperature: 23 °C	Air Pressure: 1013 hPa	Relative Humidity: 48 %	Power Supply: 120 VAC
Remarks:			

Plot 7.5.99 Radiated emission measurements from 2500 to 2900 MHz at the high carrier frequency

TEST SITE: Anechoic chamber
 TEST DISTANCE: 3 m
 ANTENNA POLARIZATION: Vertical and Horizontal
 INPUTS: 802.11 b/g + 802.11 a + licensed
 DETECTOR: Peak

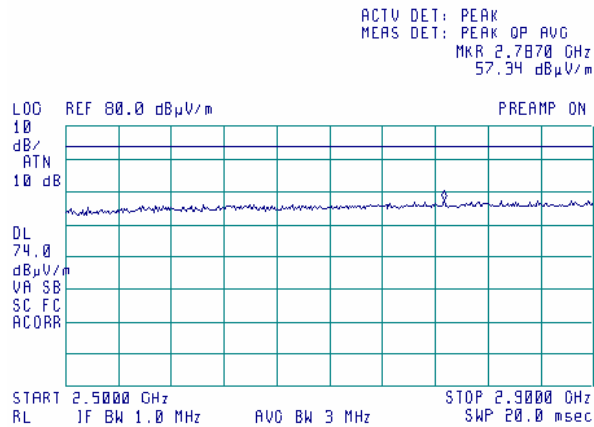

Plot 7.5.100 Radiated emission measurements from 2500 to 2900 MHz at the high carrier frequency

TEST SITE: Anechoic chamber
 TEST DISTANCE: 3 m
 ANTENNA POLARIZATION: Vertical and Horizontal
 INPUTS: 802.11 b/g + 802.11 a + licensed
 DETECTOR: Average

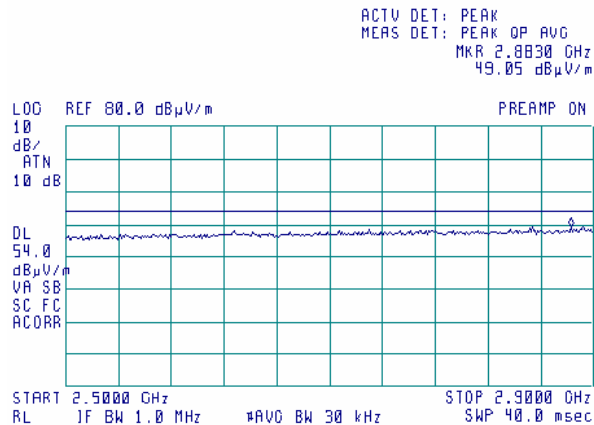

Test specification:	Section 15.247(c), Radiated spurious emissions		
Test procedure:	FR Vol. 62, page 26243, Section 15.247(c) / ANSI C63.4, Section 13.1.4		
Test mode:	Compliance	Verdict:	PASS
Date & Time:	6/6/2006 1:35:17 PM		
Temperature: 23 °C	Air Pressure: 1013 hPa	Relative Humidity: 48 %	Power Supply: 120 VAC
Remarks:			

Plot 7.5.101 Radiated emission measurements from 2900 to 4000 MHz at the low carrier frequency

TEST SITE: Anechoic chamber
 TEST DISTANCE: 3 m
 ANTENNA POLARIZATION: Vertical and Horizontal
 INPUTS: 802.11 b/g + 802.11 a + licensed

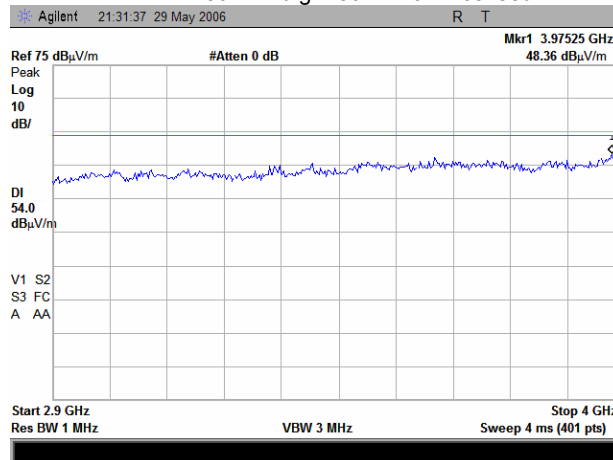

Plot 7.5.102 Radiated emission measurements from 2900 to 4000 MHz at the mid carrier frequency

TEST SITE: Anechoic chamber
 TEST DISTANCE: 3 m
 ANTENNA POLARIZATION: Vertical and Horizontal
 INPUTS: 802.11 b/g + 802.11 a + licensed

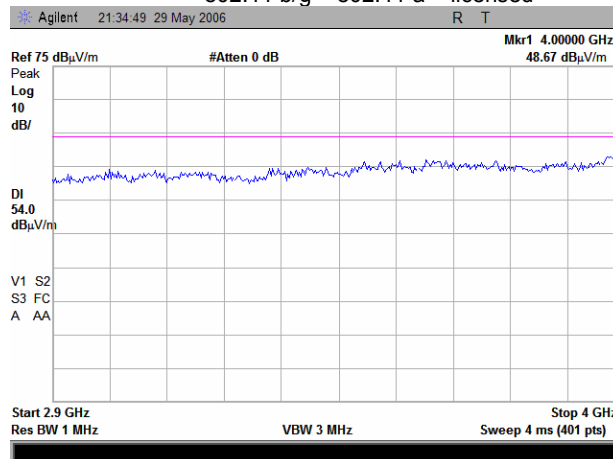

Test specification:	Section 15.247(c), Radiated spurious emissions		
Test procedure:	FR Vol. 62, page 26243, Section 15.247(c) / ANSI C63.4, Section 13.1.4		
Test mode:	Compliance	Verdict:	PASS
Date & Time:	6/6/2006 1:35:17 PM		
Temperature: 23 °C	Air Pressure: 1013 hPa	Relative Humidity: 48 %	Power Supply: 120 VAC
Remarks:			

Plot 7.5.103 Radiated emission measurements from 2900 to 4000 MHz at the high carrier frequency

TEST SITE: Anechoic chamber
 TEST DISTANCE: 3 m
 ANTENNA POLARIZATION: Vertical and Horizontal
 INPUTS: 802.11 b/g + 802.11 a + licensed

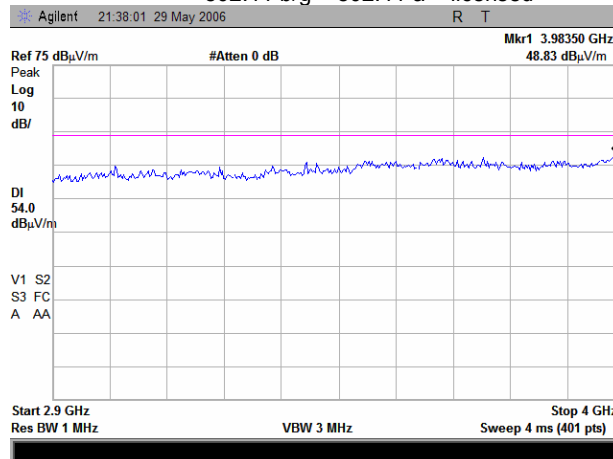

Plot 7.5.104 Radiated emission measurements from 4000 to 5150 MHz at the low carrier frequency

TEST SITE: Anechoic chamber
 TEST DISTANCE: 3 m
 ANTENNA POLARIZATION: Vertical and Horizontal
 INPUTS: 802.11 b/g + 802.11 a + licensed

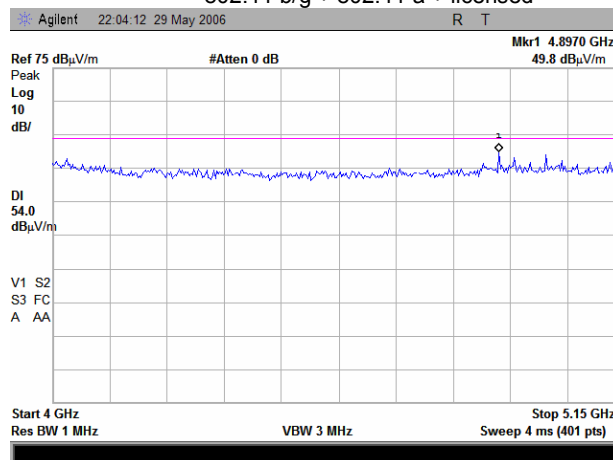

Test specification:		Section 15.247(c), Radiated spurious emissions	
Test procedure: FR Vol. 62, page 26243, Section 15.247(c) / ANSI C63.4, Section 13.1.4			
Test mode: Compliance		Verdict: PASS	
Date & Time: 6/6/2006 1:35:17 PM			
Temperature: 23 °C	Air Pressure: 1013 hPa	Relative Humidity: 48 %	Power Supply: 120 VAC
Remarks:			

Plot 7.5.105 Radiated emission measurements from 4000 to 5150 MHz at the mid carrier frequency

TEST SITE: Anechoic chamber
 TEST DISTANCE: 3 m
 ANTENNA POLARIZATION: Vertical and Horizontal
 INPUTS: 802.11 b/g + 802.11 a + licensed

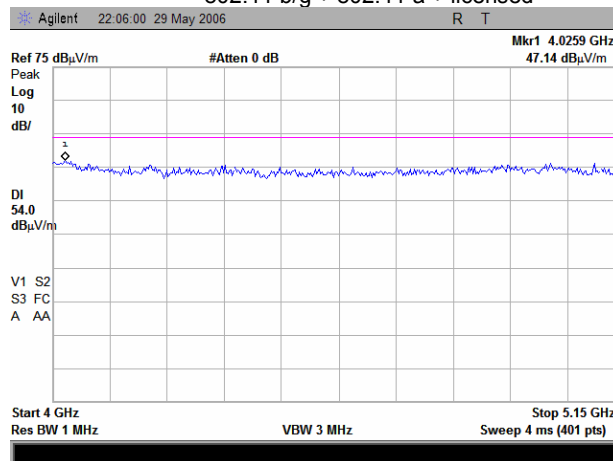

Plot 7.5.106 Radiated emission measurements from 4000 to 5150 MHz at the high carrier frequency

TEST SITE: Anechoic chamber
 TEST DISTANCE: 3 m
 ANTENNA POLARIZATION: Vertical and Horizontal
 INPUTS: 802.11 b/g + 802.11 a + licensed

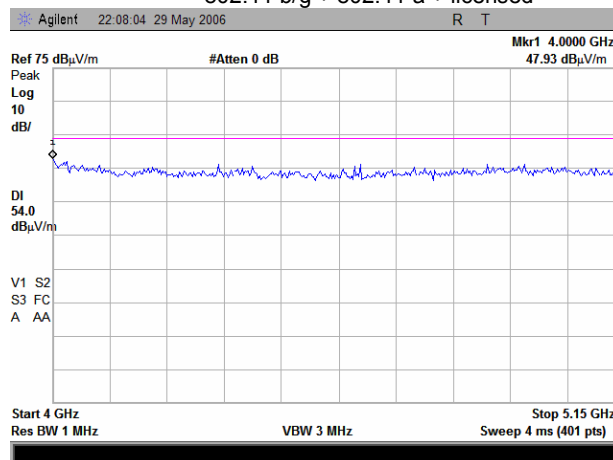

Test specification:		Section 15.247(c), Radiated spurious emissions	
Test procedure:		FR Vol. 62, page 26243, Section 15.247(c) / ANSI C63.4, Section 13.1.4	
Test mode:	Compliance	Verdict:	PASS
Date & Time:	6/6/2006 1:35:17 PM		
Temperature: 23 °C	Air Pressure: 1013 hPa	Relative Humidity: 48 %	Power Supply: 120 VAC
Remarks:			

Plot 7.5.107 Radiated emission measurements from 5350 to 5460 MHz at the low carrier frequency

TEST SITE: Anechoic chamber
 TEST DISTANCE: 3 m
 ANTENNA POLARIZATION: Vertical and Horizontal
 INPUTS: 802.11 b/g + 802.11 a + licensed

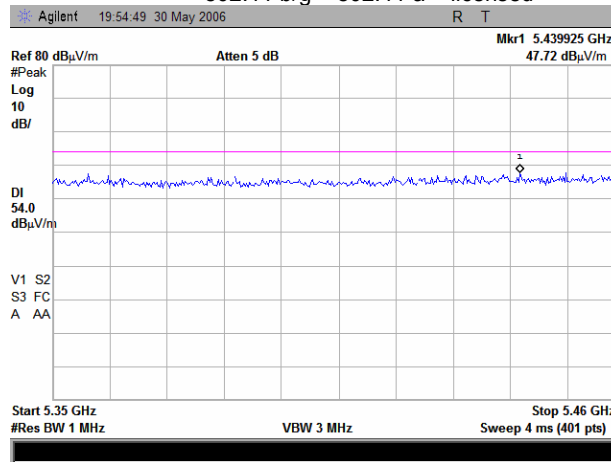

Plot 7.5.108 Radiated emission measurements from 5350 to 5460 MHz at the mid carrier frequency

TEST SITE: Anechoic chamber
 TEST DISTANCE: 3 m
 ANTENNA POLARIZATION: Vertical and Horizontal
 INPUTS: 802.11 b/g + 802.11 a + licensed

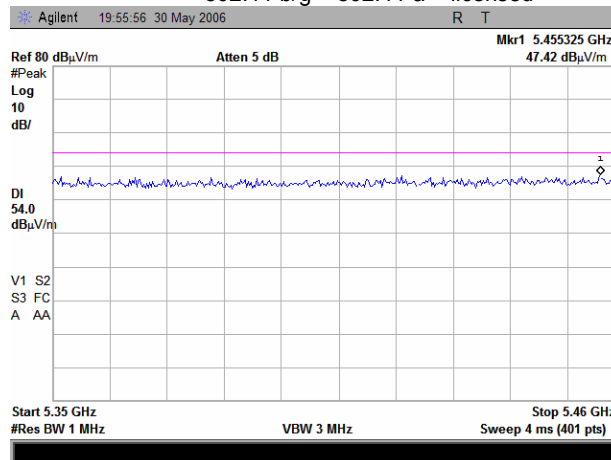

Test specification:	Section 15.247(c), Radiated spurious emissions		
Test procedure:	FR Vol. 62, page 26243, Section 15.247(c) / ANSI C63.4, Section 13.1.4		
Test mode:	Compliance	Verdict:	PASS
Date & Time:	6/6/2006 1:35:17 PM		
Temperature: 23 °C	Air Pressure: 1013 hPa	Relative Humidity: 48 %	Power Supply: 120 VAC
Remarks:			

Plot 7.5.109 Radiated emission measurements from 5350 to 5460 MHz at the high carrier frequency

TEST SITE: Anechoic chamber
 TEST DISTANCE: 3 m
 ANTENNA POLARIZATION: Vertical and Horizontal
 INPUTS: 802.11 b/g + 802.11 a + licensed

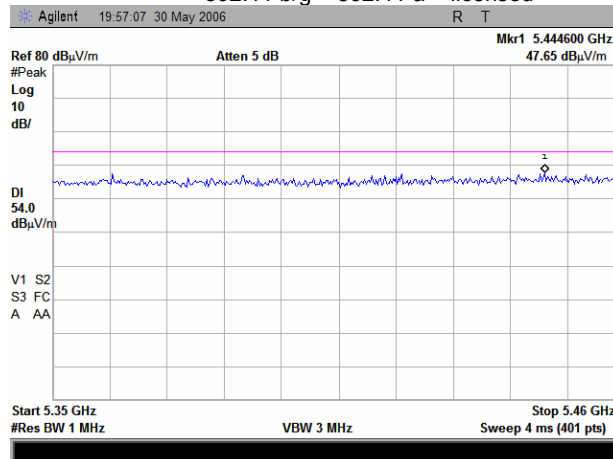

Test specification:	Section 15.247(c), Radiated spurious emissions		
Test procedure:	FR Vol. 62, page 26243, Section 15.247(c) / ANSI C63.4, Section 13.1.4		
Test mode:	Compliance	Verdict:	PASS
Date & Time:	6/6/2006 1:35:17 PM		
Temperature: 23 °C	Air Pressure: 1013 hPa	Relative Humidity: 48 %	Power Supply: 120 VAC
Remarks:			

Plot 7.5.110 Radiated emission measurements from 5.46 to 8.0 GHz at the low carrier frequency

TEST SITE: Anechoic chamber
 TEST DISTANCE: 3 m
 ANTENNA POLARIZATION: Vertical and Horizontal
 INPUTS: 802.11 b/g + 802.11 a + licensed
 DETECTOR: Peak

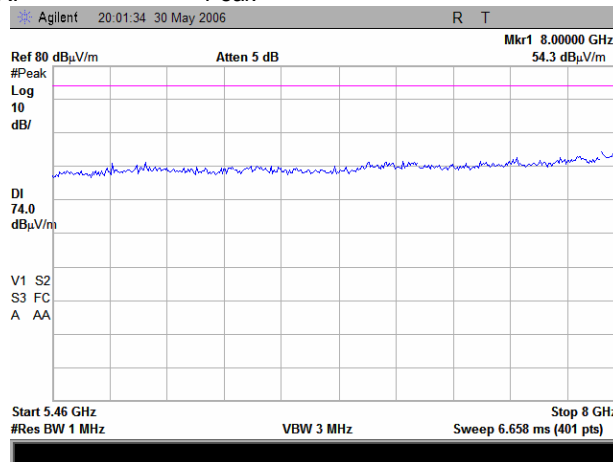

Plot 7.5.111 Radiated emission measurements from 5.46 to 8.0 GHz at the low carrier frequency

TEST SITE: Anechoic chamber
 TEST DISTANCE: 3 m
 ANTENNA POLARIZATION: Vertical and Horizontal
 INPUTS: 802.11 b/g + 802.11 a + licensed
 DETECTOR: Average

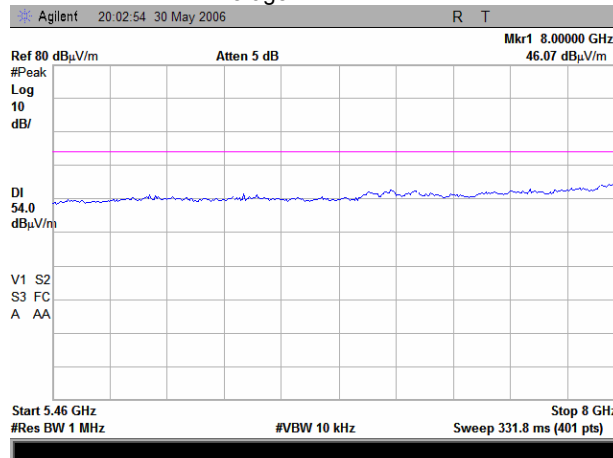

Test specification:	Section 15.247(c), Radiated spurious emissions		
Test procedure:	FR Vol. 62, page 26243, Section 15.247(c) / ANSI C63.4, Section 13.1.4		
Test mode:	Compliance	Verdict:	PASS
Date & Time:	6/6/2006 1:35:17 PM		
Temperature: 23 °C	Air Pressure: 1013 hPa	Relative Humidity: 48 %	Power Supply: 120 VAC
Remarks:			

Plot 7.5.112 Radiated emission measurements from 5.46 to 8.0 GHz at the mid carrier frequency

TEST SITE: Anechoic chamber
 TEST DISTANCE: 3 m
 ANTENNA POLARIZATION: Vertical and Horizontal
 INPUTS: 802.11 b/g + 802.11 a + licensed
 DETECTOR: Peak

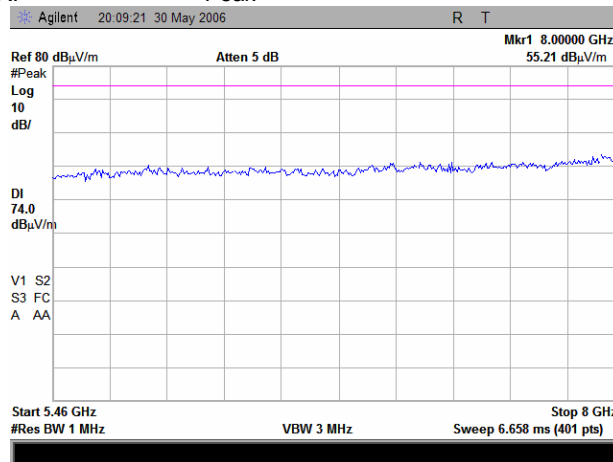

Plot 7.5.113 Radiated emission measurements from 5.46 to 8.0 GHz at the mid carrier frequency

TEST SITE: Anechoic chamber
 TEST DISTANCE: 3 m
 ANTENNA POLARIZATION: Vertical and Horizontal
 INPUTS: 802.11 b/g + 802.11 a + licensed
 DETECTOR: Average

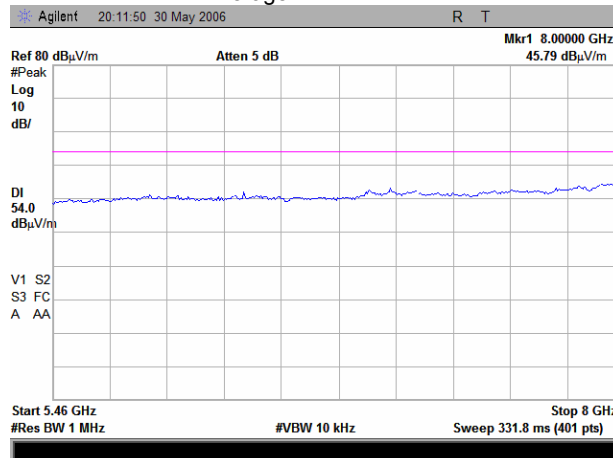

Test specification:	Section 15.247(c), Radiated spurious emissions		
Test procedure:	FR Vol. 62, page 26243, Section 15.247(c) / ANSI C63.4, Section 13.1.4		
Test mode:	Compliance	Verdict:	PASS
Date & Time:	6/6/2006 1:35:17 PM		
Temperature: 23 °C	Air Pressure: 1013 hPa	Relative Humidity: 48 %	Power Supply: 120 VAC
Remarks:			

Plot 7.5.114 Radiated emission measurements from 5.46 to 8.0 GHz at the high carrier frequency

TEST SITE: Anechoic chamber
 TEST DISTANCE: 3 m
 ANTENNA POLARIZATION: Vertical and Horizontal
 INPUTS: 802.11 b/g + 802.11 a + licensed
 DETECTOR: Peak

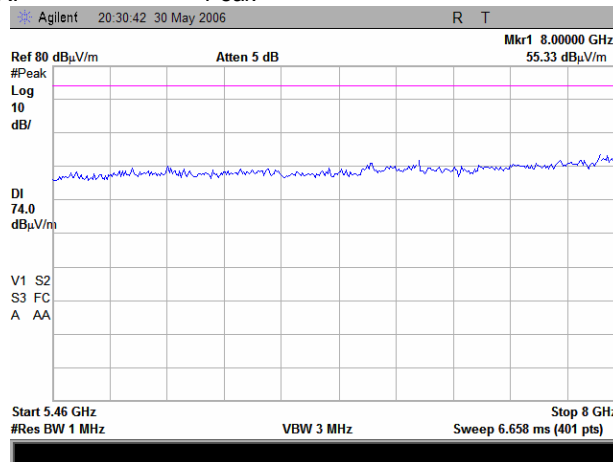

Plot 7.5.115 Radiated emission measurements from 5.46 to 8.0 GHz at the high carrier frequency

TEST SITE: Anechoic chamber
 TEST DISTANCE: 3 m
 ANTENNA POLARIZATION: Vertical and Horizontal
 INPUTS: 802.11 b/g + 802.11 a + licensed
 DETECTOR: Average

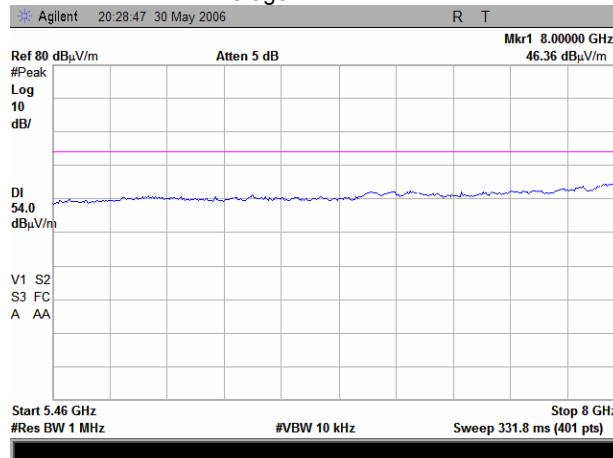

Test specification:	Section 15.247(c), Radiated spurious emissions		
Test procedure:	FR Vol. 62, page 26243, Section 15.247(c) / ANSI C63.4, Section 13.1.4		
Test mode:	Compliance	Verdict:	PASS
Date & Time:	6/6/2006 1:35:17 PM		
Temperature: 23 °C	Air Pressure: 1013 hPa	Relative Humidity: 48 %	Power Supply: 120 VAC
Remarks:			

Plot 7.5.116 Radiated emission measurements from 8.0 to 14.0 GHz at the low carrier frequency

TEST SITE: Anechoic chamber
 TEST DISTANCE: 3 m
 ANTENNA POLARIZATION: Vertical and Horizontal
 INPUTS: 802.11 b/g + 802.11 a + licensed
 DETECTOR: Peak

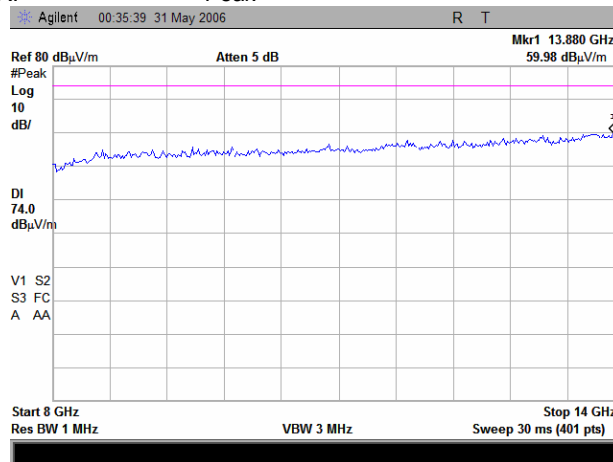

Plot 7.5.117 Radiated emission measurements from 8.0 to 14.0 GHz at the low carrier frequency

TEST SITE: Anechoic chamber
 TEST DISTANCE: 3 m
 ANTENNA POLARIZATION: Vertical and Horizontal
 INPUTS: 802.11 b/g + 802.11 a + licensed
 DETECTOR: Average

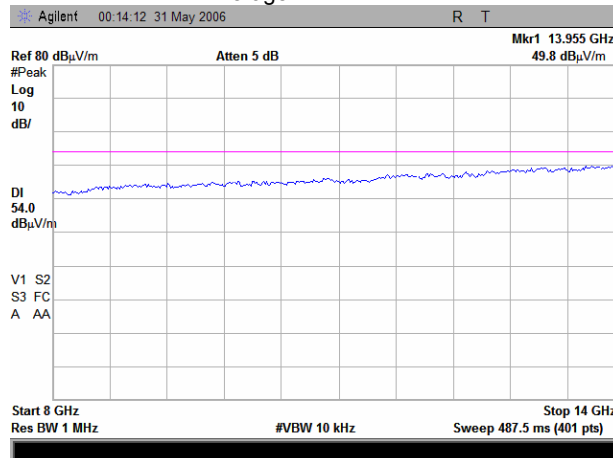

Test specification:	Section 15.247(c), Radiated spurious emissions		
Test procedure:	FR Vol. 62, page 26243, Section 15.247(c) / ANSI C63.4, Section 13.1.4		
Test mode:	Compliance	Verdict:	PASS
Date & Time:	6/6/2006 1:35:17 PM		
Temperature: 23 °C	Air Pressure: 1013 hPa	Relative Humidity: 48 %	Power Supply: 120 VAC
Remarks:			

Plot 7.5.118 Radiated emission measurements from 8.0 to 14.0 GHz at the mid carrier frequency

TEST SITE: Anechoic chamber
 TEST DISTANCE: 3 m
 ANTENNA POLARIZATION: Vertical and Horizontal
 INPUTS: 802.11 b/g + 802.11 a + licensed
 DETECTOR: Peak

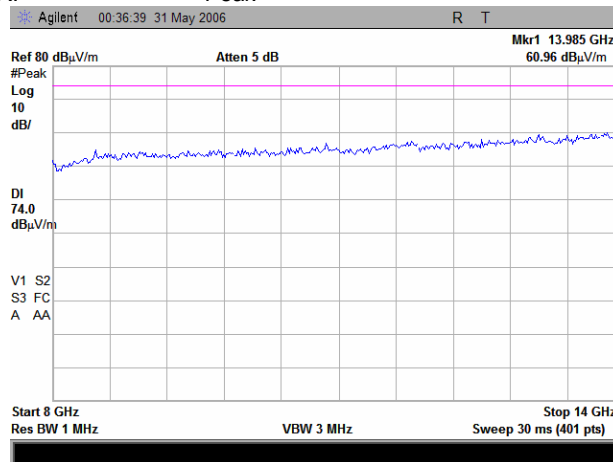

Plot 7.5.119 Radiated emission measurements from 8.0 to 14.0 GHz at the mid carrier frequency

TEST SITE: Anechoic chamber
 TEST DISTANCE: 3 m
 ANTENNA POLARIZATION: Vertical and Horizontal
 INPUTS: 802.11 b/g + 802.11 a + licensed
 DETECTOR: Average

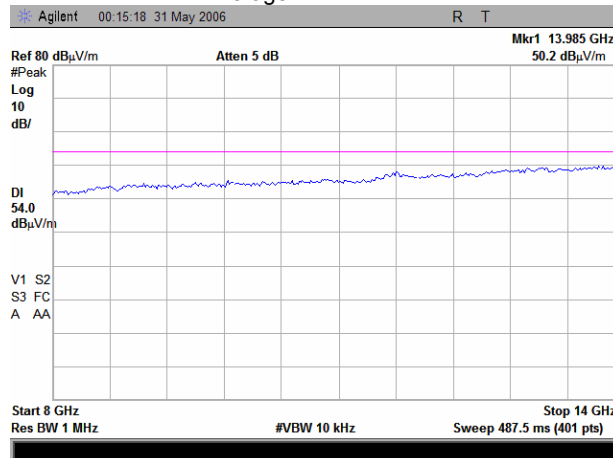

Test specification: Section 15.247(c), Radiated spurious emissions			
Test procedure: FR Vol. 62, page 26243, Section 15.247(c) / ANSI C63.4, Section 13.1.4			
Test mode: Compliance	Verdict: PASS		
Date & Time: 6/6/2006 1:35:17 PM			
Temperature: 23 °C	Air Pressure: 1013 hPa	Relative Humidity: 48 %	Power Supply: 120 VAC
Remarks:			

Plot 7.5.120 Radiated emission measurements from 8.0 to 14.0 GHz at the high carrier frequency

TEST SITE: Anechoic chamber
 TEST DISTANCE: 3 m
 ANTENNA POLARIZATION: Vertical and Horizontal
 INPUTS: 802.11 b/g + 802.11 a + licensed
 DETECTOR: Peak

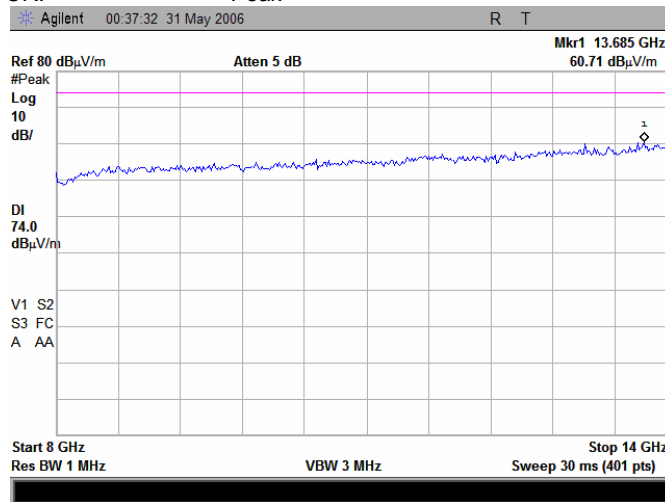

Plot 7.5.121 Radiated emission measurements from 8.0 to 14.0 GHz at the high carrier frequency

TEST SITE: Anechoic chamber
 TEST DISTANCE: 3 m
 ANTENNA POLARIZATION: Vertical and Horizontal
 INPUTS: 802.11 b/g + 802.11 a + licensed
 DETECTOR: Average

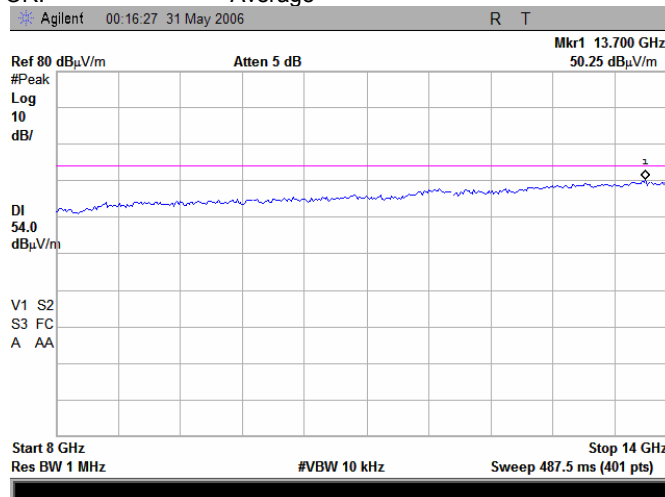

Test specification:	Section 15.247(c), Radiated spurious emissions		
Test procedure:	FR Vol. 62, page 26243, Section 15.247(c) / ANSI C63.4, Section 13.1.4		
Test mode:	Compliance	Verdict:	PASS
Date & Time:	6/6/2006 1:35:17 PM		
Temperature: 23 °C	Air Pressure: 1013 hPa	Relative Humidity: 48 %	Power Supply: 120 VAC
Remarks:			

Plot 7.5.122 Radiated emission measurements from 14.0 to 18.0 GHz at the low carrier frequency

TEST SITE: Anechoic chamber
 TEST DISTANCE: 3 m
 ANTENNA POLARIZATION: Vertical and Horizontal
 INPUTS: 802.11 b/g + 802.11 a + licensed
 DETECTOR: Peak

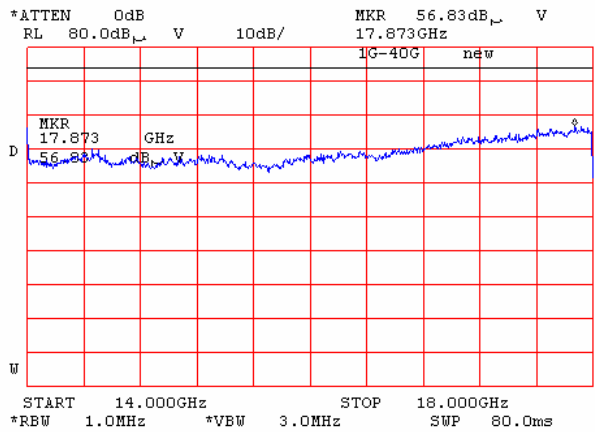

Plot 7.5.123 Radiated emission measurements from 14.0 to 18.0 GHz at the low carrier frequency

TEST SITE: Anechoic chamber
 TEST DISTANCE: 3 m
 ANTENNA POLARIZATION: Vertical and Horizontal
 INPUTS: 802.11 b/g + 802.11 a + licensed
 DETECTOR: average

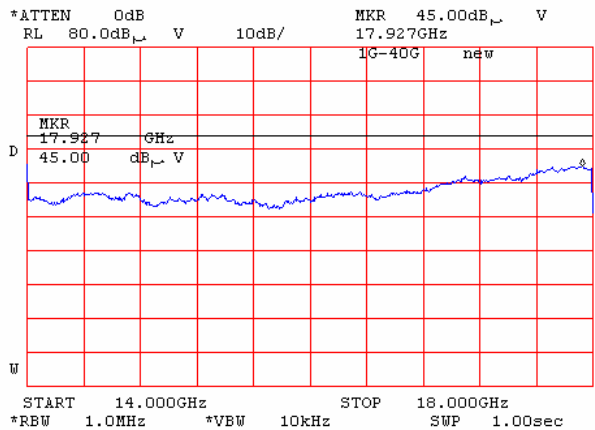

Test specification:	Section 15.247(c), Radiated spurious emissions		
Test procedure:	FR Vol. 62, page 26243, Section 15.247(c) / ANSI C63.4, Section 13.1.4		
Test mode:	Compliance	Verdict:	PASS
Date & Time:	6/6/2006 1:35:17 PM		
Temperature: 23 °C	Air Pressure: 1013 hPa	Relative Humidity: 48 %	Power Supply: 120 VAC
Remarks:			

Plot 7.5.124 Radiated emission measurements from 14.0 to 18.0 GHz at the mid carrier frequency

TEST SITE: Anechoic chamber
 TEST DISTANCE: 3 m
 ANTENNA POLARIZATION: Vertical and Horizontal
 INPUTS: 802.11 b/g + 802.11 a + licensed
 DETECTOR: Peak

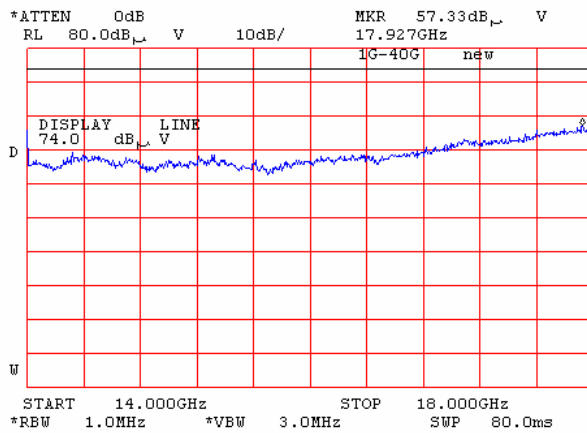

Plot 7.5.125 Radiated emission measurements from 14.0 to 18.0 GHz at the mid carrier frequency

TEST SITE: Anechoic chamber
 TEST DISTANCE: 3 m
 ANTENNA POLARIZATION: Vertical and Horizontal
 INPUTS: 802.11 b/g + 802.11 a + licensed
 DETECTOR: average

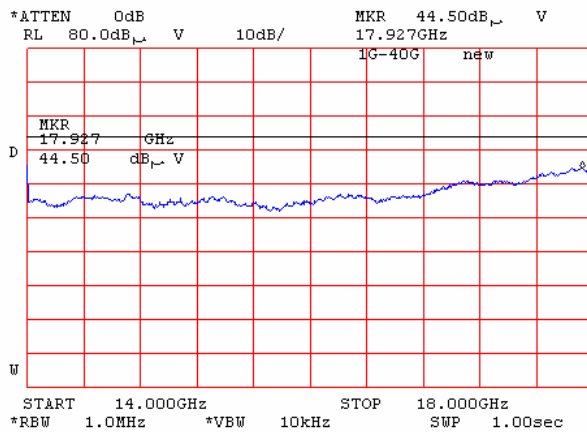

Test specification:	Section 15.247(c), Radiated spurious emissions		
Test procedure:	FR Vol. 62, page 26243, Section 15.247(c) / ANSI C63.4, Section 13.1.4		
Test mode:	Compliance	Verdict:	PASS
Date & Time:	6/6/2006 1:35:17 PM		
Temperature: 23 °C	Air Pressure: 1013 hPa	Relative Humidity: 48 %	Power Supply: 120 VAC
Remarks:			

Plot 7.5.126 Radiated emission measurements from 14.0 to 18.0 GHz at the high carrier frequency

TEST SITE: Anechoic chamber
 TEST DISTANCE: 3 m
 ANTENNA POLARIZATION: Vertical and Horizontal
 INPUTS: 802.11 b/g + 802.11 a + licensed
 DETECTOR: Peak

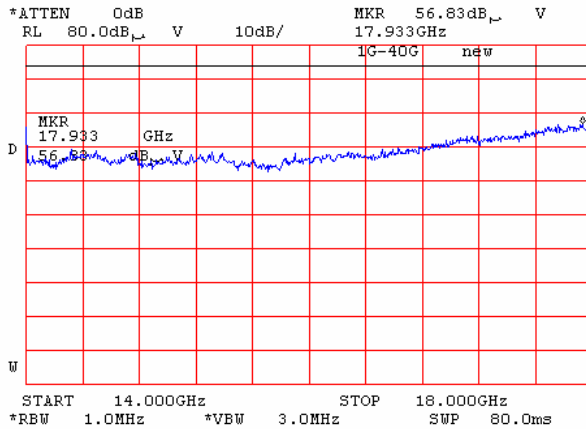

Plot 7.5.127 Radiated emission measurements from 14.0 to 18.0 GHz at the high carrier frequency

TEST SITE: Anechoic chamber
 TEST DISTANCE: 3 m
 ANTENNA POLARIZATION: Vertical and Horizontal
 INPUTS: 802.11 b/g + 802.11 a + licensed
 DETECTOR: average

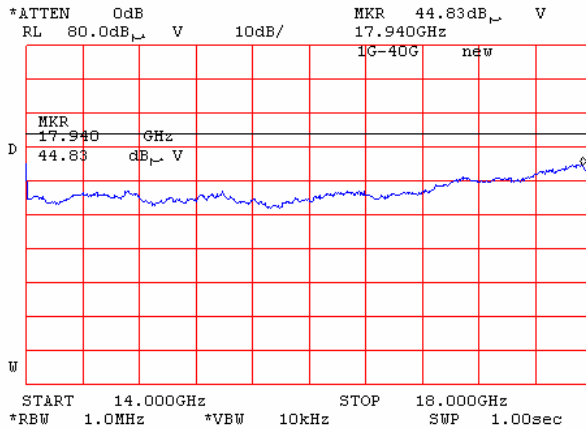

Test specification:	Section 15.247(c), Radiated spurious emissions		
Test procedure:	FR Vol. 62, page 26243, Section 15.247(c) / ANSI C63.4, Section 13.1.4		
Test mode:	Compliance	Verdict:	PASS
Date & Time:	6/6/2006 1:35:17 PM		
Temperature: 23 °C	Air Pressure: 1013 hPa	Relative Humidity: 48 %	Power Supply: 120 VAC
Remarks:			

Plot 7.5.128 Radiated emission measurements from 18.0 to 26.5 GHz at the low carrier frequency

TEST SITE: Anechoic chamber
 TEST DISTANCE: 3 m
 ANTENNA POLARIZATION: Vertical and Horizontal
 INPUTS: 802.11 b/g + 802.11 a + licensed
 DETECTOR: Peak

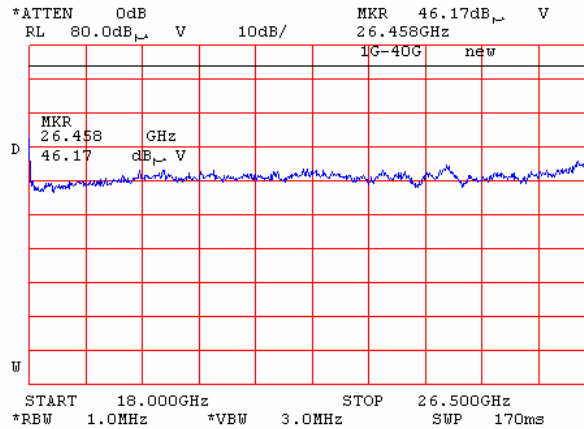

Plot 7.5.129 Radiated emission measurements from 18.0 to 26.5 GHz at the mid carrier frequency

TEST SITE: Anechoic chamber
 TEST DISTANCE: 3 m
 ANTENNA POLARIZATION: Vertical and Horizontal
 INPUTS: 802.11 b/g + 802.11 a + licensed
 DETECTOR: Peak

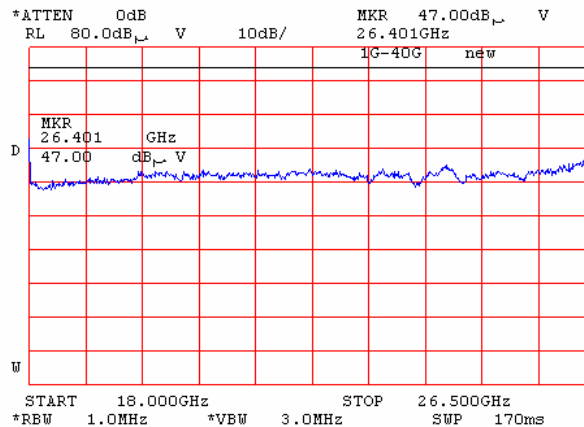

Test specification:	Section 15.247(c), Radiated spurious emissions		
Test procedure:	FR Vol. 62, page 26243, Section 15.247(c) / ANSI C63.4, Section 13.1.4		
Test mode:	Compliance	Verdict:	PASS
Date & Time:	6/6/2006 1:35:17 PM		
Temperature: 23 °C	Air Pressure: 1013 hPa	Relative Humidity: 48 %	Power Supply: 120 VAC
Remarks:			

Plot 7.5.130 Radiated emission measurements from 18.0 to 26.5 GHz at the high carrier frequency

TEST SITE: Anechoic chamber
 TEST DISTANCE: 3 m
 ANTENNA POLARIZATION: Vertical and Horizontal
 INPUTS: 802.11 b/g + 802.11 a + licensed
 DETECTOR: Peak

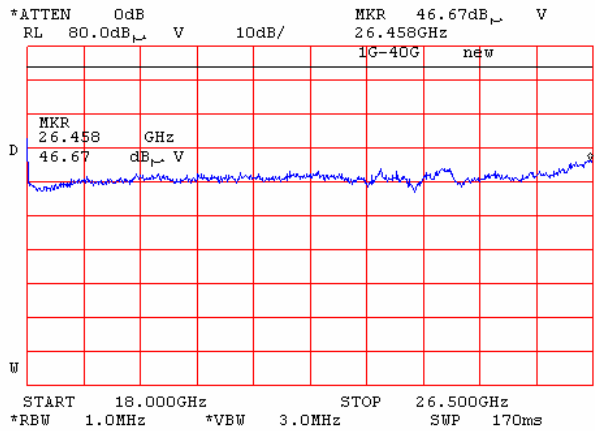

Test specification:	Section 15.247(c), Radiated spurious emissions		
Test procedure:	FR Vol. 62, page 26243, Section 15.247(c) / ANSI C63.4, Section 13.1.4		
Test mode:	Compliance	Verdict: PASS	
Date & Time:	6/6/2006 1:35:17 PM		
Temperature: 23 °C	Air Pressure: 1013 hPa	Relative Humidity: 48 %	Power Supply: 120 VAC
Remarks:			

Plot 7.5.131 Radiated emission measurements at the second harmonic of low carrier frequency

TEST SITE: OATS
TEST DISTANCE: 3 m

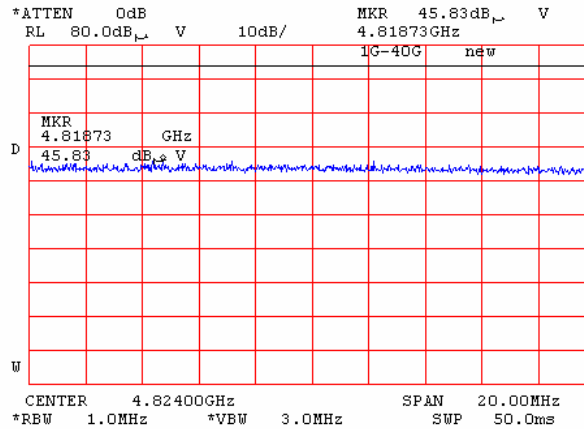

Plot 7.5.132 Radiated emission measurements at the second harmonic of mid carrier frequency

TEST SITE: OATS
TEST DISTANCE: 3 m

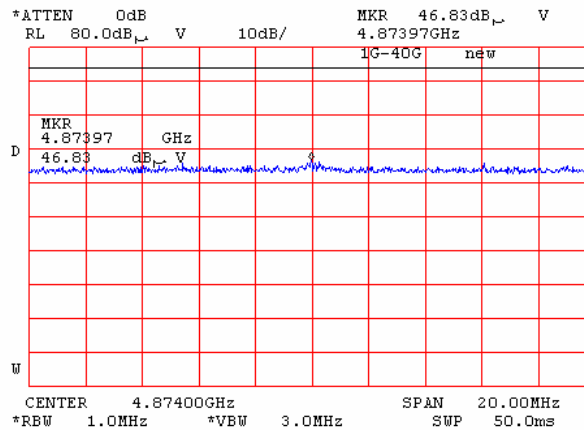

Test specification:	Section 15.247(c), Radiated spurious emissions		
Test procedure:	FR Vol. 62, page 26243, Section 15.247(c) / ANSI C63.4, Section 13.1.4		
Test mode:	Compliance	Verdict:	PASS
Date & Time:	6/6/2006 1:35:17 PM		
Temperature: 23 °C	Air Pressure: 1013 hPa	Relative Humidity: 48 %	Power Supply: 120 VAC
Remarks:			

Plot 7.5.133 Radiated emission measurements at the second harmonic of high carrier frequency

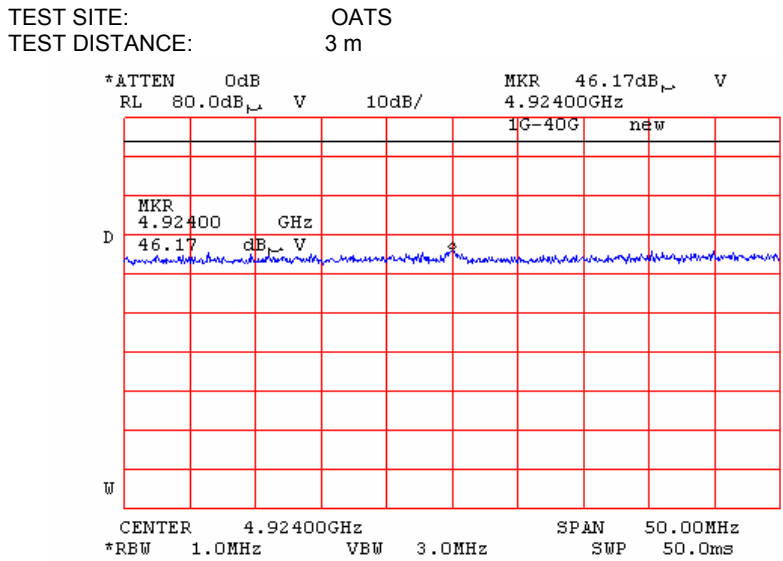

Plot 7.5.134 Radiated emission measurements at the third harmonic of low carrier frequency

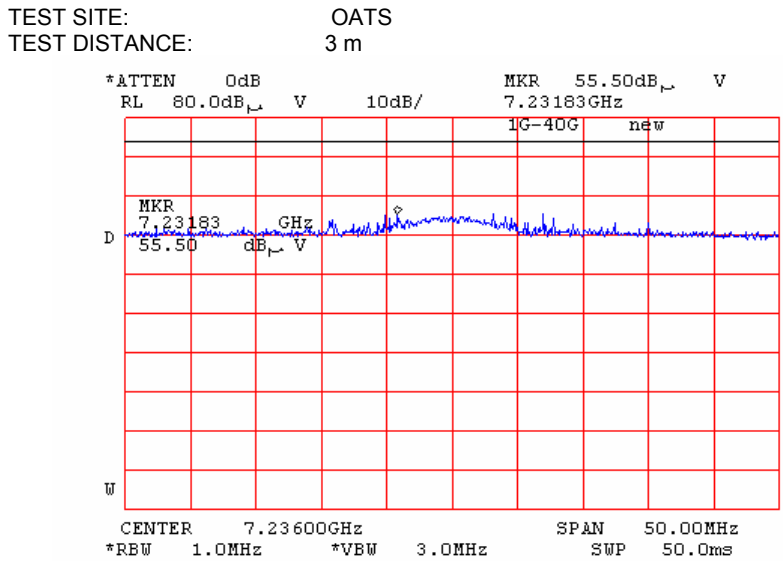

Test specification:	Section 15.247(c), Radiated spurious emissions		
Test procedure:	FR Vol. 62, page 26243, Section 15.247(c) / ANSI C63.4, Section 13.1.4		
Test mode:	Compliance	Verdict:	PASS
Date & Time:	6/6/2006 1:35:17 PM		
Temperature: 23 °C	Air Pressure: 1013 hPa	Relative Humidity: 48 %	Power Supply: 120 VAC
Remarks:			

Plot 7.5.135 Radiated emission measurements at the third harmonic of mid carrier frequency

TEST SITE: OATS
TEST DISTANCE: 3 m
DETECTOR: peak

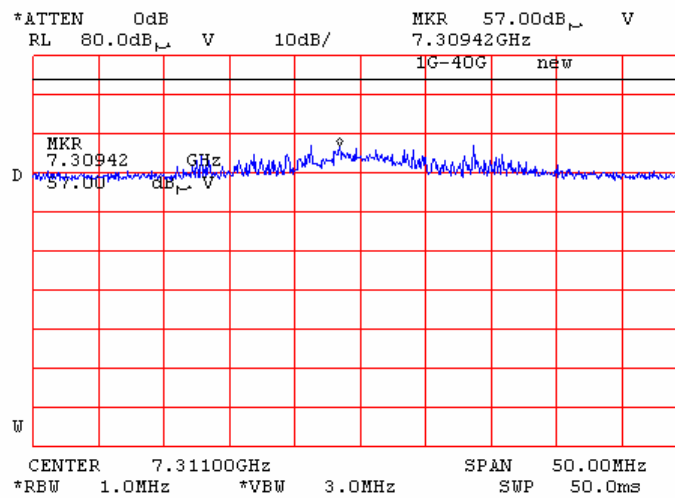

Plot 7.5.136 Radiated emission measurements at the third harmonic of mid carrier frequency

TEST SITE: OATS
TEST DISTANCE: 3 m
DETECTOR: average

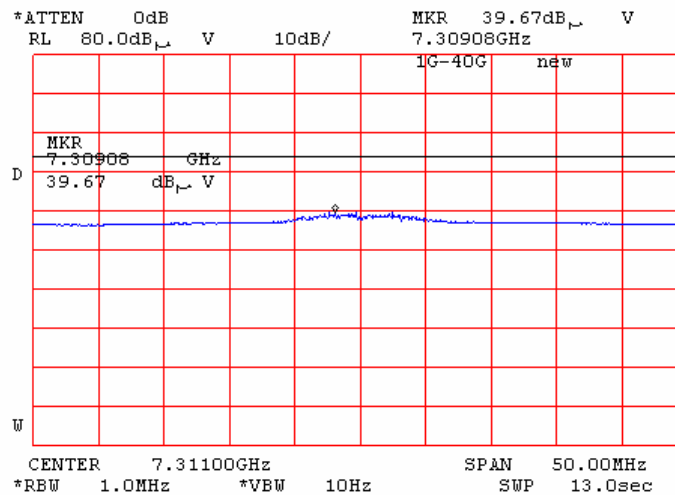

Test specification:	Section 15.247(c), Radiated spurious emissions		
Test procedure:	FR Vol. 62, page 26243, Section 15.247(c) / ANSI C63.4, Section 13.1.4		
Test mode:	Compliance	Verdict:	PASS
Date & Time:	6/6/2006 1:35:17 PM		
Temperature: 23 °C	Air Pressure: 1013 hPa	Relative Humidity: 48 %	Power Supply: 120 VAC
Remarks:			

Plot 7.5.137 Radiated emission measurements at the third harmonic of high carrier frequency

TEST SITE: OATS
TEST DISTANCE: 3 m
DETECTOR: peak

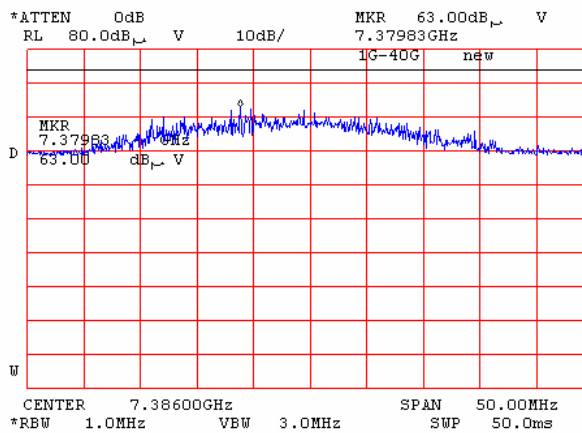

Plot 7.5.138 Radiated emission measurements at the third harmonic of high carrier frequency

TEST SITE: OATS
TEST DISTANCE: 3 m
DETECTOR: average

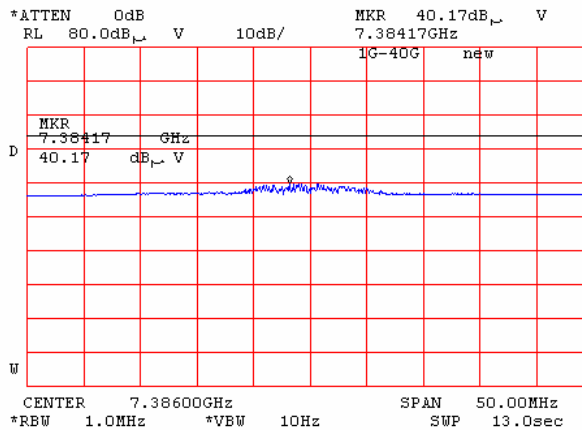

Test specification:	Section 15.247(c), Radiated spurious emissions		
Test procedure:	FR Vol. 62, page 26243, Section 15.247(c) / ANSI C63.4, Section 13.1.4		
Test mode:	Compliance	Verdict: PASS	
Date & Time:	6/6/2006 1:35:17 PM		
Temperature: 23 °C	Air Pressure: 1013 hPa	Relative Humidity: 48 %	Power Supply: 120 VAC
Remarks:			

Plot 7.5.139 Radiated emission measurements at the fourth harmonic of low carrier frequency

TEST SITE: OATS
TEST DISTANCE: 3 m

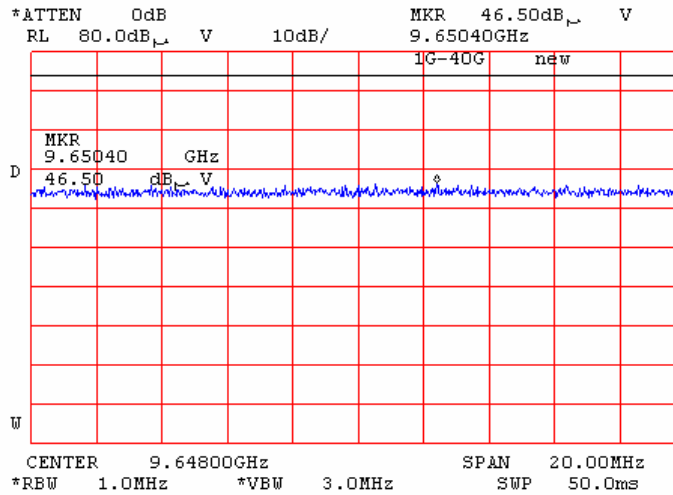

Plot 7.5.140 Radiated emission measurements at the fourth harmonic of mid carrier frequency

TEST SITE: OATS
TEST DISTANCE: 3 m

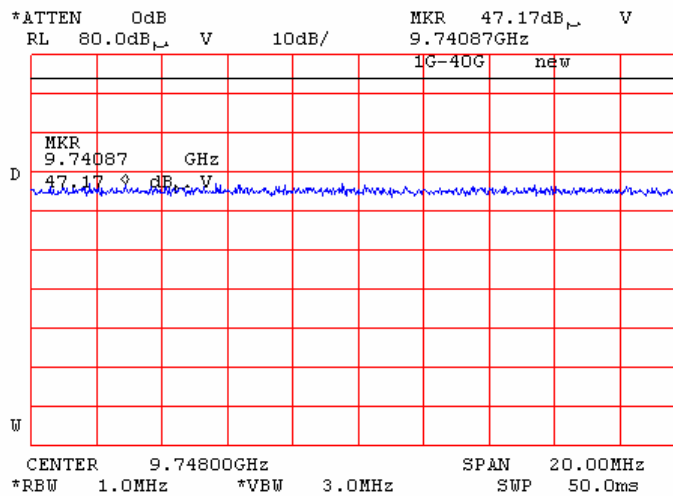

Test specification:	Section 15.247(c), Radiated spurious emissions		
Test procedure:	FR Vol. 62, page 26243, Section 15.247(c) / ANSI C63.4, Section 13.1.4		
Test mode:	Compliance	Verdict:	PASS
Date & Time:	6/6/2006 1:35:17 PM		
Temperature: 23 °C	Air Pressure: 1013 hPa	Relative Humidity: 48 %	Power Supply: 120 VAC
Remarks:			

Plot 7.5.141 Radiated emission measurements at the fourth harmonic of high carrier frequency

TEST SITE: OATS
TEST DISTANCE: 3 m

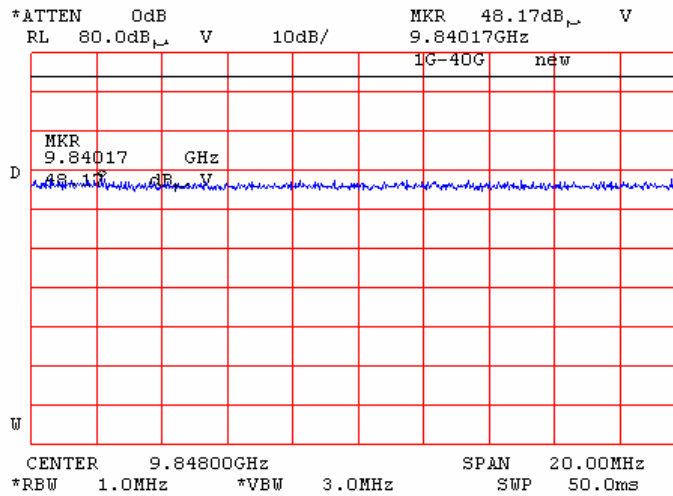

Test specification:	Section 15.247(c), Radiated spurious emissions		
Test procedure:	FR Vol. 62, page 26243, Section 15.247(c) / ANSI C63.4, Section 13.1.4		
Test mode:	Compliance	Verdict:	
Date & Time:	6/28/2006 2:24:40 PM		
Temperature: 24 °C	Air Pressure: 1014 hPa	Relative Humidity: 50 %	Power Supply: 120 VAC
Remarks: 802.11b/g			

7.6 Field strength of spurious emissions

7.6.1 General

This test was performed to measure field strength of spurious emissions from the EUT. Specification test limits are given in Table 7.6.1.

Table 7.6.1 Radiated spurious emissions limits

Frequency, MHz	Field strength at 3 m within restricted bands, dB(μV/m)*		
	Peak	Quasi Peak	Average
0.009 – 0.090	148.5 – 128.5	NA	128.5 – 108.5**
0.090 – 0.110	NA	108.5 – 106.8**	NA
0.110 – 0.490	126.8 – 113.8	NA	106.8 – 93.8**
0.490 – 1.705	NA	73.8 – 63.0**	NA
1.705 – 30.0*		69.5	
30 – 88		40.0	
88 – 216		43.5	
216 – 960		46.0	
960 - 1000		54.0	
1000 – 10 th harmonic		74.0	

*- The limit for 3 m test distance was calculated using the inverse square distance extrapolation factor as follows:

$$\text{Lim}_{S_2} = \text{Lim}_{S_1} + 40 \log (S_1/S_2),$$

where S_1 and S_2 – standard defined and test distance respectively in meters.

** - The limit decreases linearly with the logarithm of frequency.

*** - The field strength limits applied from the lowest radio frequency generated in the device, without going below 9 kHz up to the tenth harmonic of the highest fundamental frequency.

7.6.2 Test procedure for spurious emission field strength measurements in 9 kHz to 30 MHz band

7.6.2.1 The EUT was set up as shown in Figure 7.5.1, energized and the performance check was conducted.

7.6.2.2 The specified frequency range was investigated with antenna connected to spectrum analyzer/ EMI receiver. To find maximum radiation the turntable was rotated 360° and the measuring antenna was rotated around its vertical axis.

7.6.2.3 The worst test results (the lowest margins) were recorded and shown in the associated plots.

7.6.3 Test procedure for spurious emission field strength measurements above 30 MHz

7.6.3.1 The EUT was set up as shown in Figure 7.5.2, energized and the performance check was conducted.

7.6.3.2 The specified frequency range was investigated with antenna connected to spectrum analyzer/ EMI receiver. To find maximum radiation the turntable was rotated 360°, the measuring antenna height was changed from 1 to 4 m, its polarization was switched from vertical to horizontal.

7.6.3.3 The worst test results (the lowest margins) were recorded and shown in the associated plots.

Test specification:	Section 15.247(c), Radiated spurious emissions		
Test procedure:	FR Vol. 62, page 26243, Section 15.247(c) / ANSI C63.4, Section 13.1.4		
Test mode:	Compliance	Verdict:	
Date & Time:	6/28/2006 2:24:40 PM		
Temperature: 24 °C	Air Pressure: 1014 hPa	Relative Humidity: 50 %	Power Supply: 120 VAC
Remarks: 802.11b/g			

Figure 7.6.1 Setup for spurious emission field strength measurements below 30 MHz

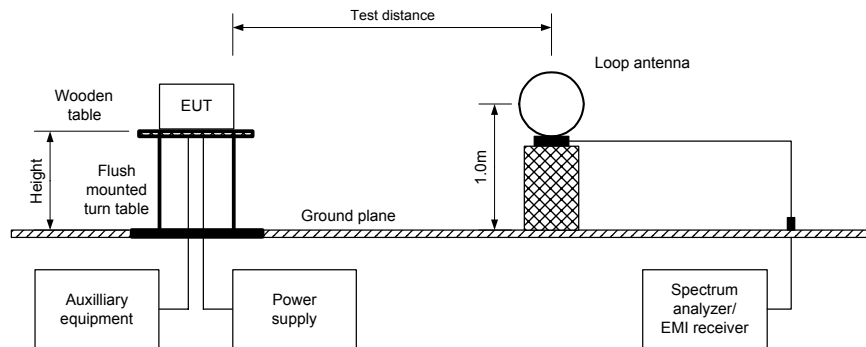
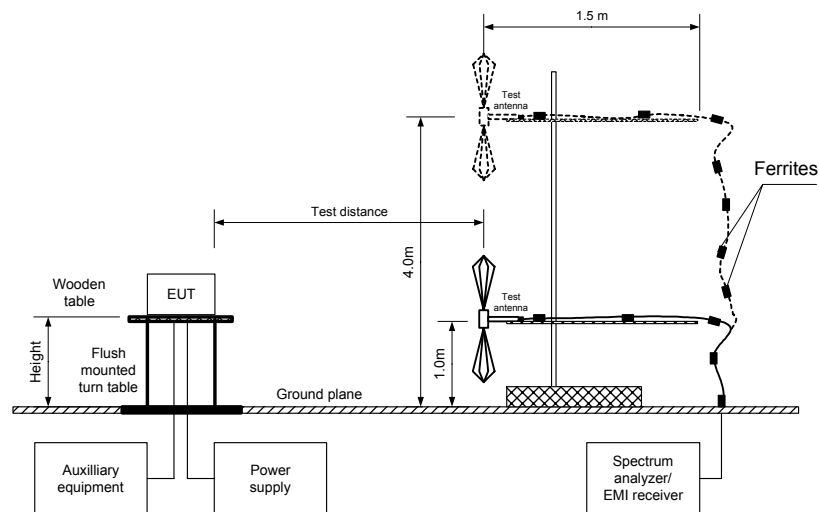

Figure 7.6.2 Setup for spurious emission field strength measurements above 30 MHz



Test specification:	Section 15.247(c), Radiated spurious emissions		
Test procedure:	FR Vol. 62, page 26243, Section 15.247(c) / ANSI C63.4, Section 13.1.4		
Test mode:	Compliance	Verdict:	
Date & Time:	6/28/2006 2:24:40 PM		
Temperature: 24 °C	Air Pressure: 1014 hPa	Relative Humidity: 50 %	Power Supply: 120 VAC
Remarks: 802.11b/g			

Table 7.6.2 Field strength of spurious emissions above 1 GHz within restricted bands

ASSIGNED FREQUENCY: 2400 – 2483.5 MHz
 INVESTIGATED FREQUENCY RANGE: 1000 – 25000 MHz
 TEST DISTANCE: 3 m
 MODULATION: OFDM
 MODULATING SIGNAL: PRBS
 BIT RATE: 1 Mbps
 DUTY CYCLE: 100 %
 TRANSMITTER OUTPUT POWER SETTINGS: Maximum

DETECTOR USED: Peak
 RESOLUTION BANDWIDTH: 1000 kHz
 TEST ANTENNA TYPE: Double ridged guide

Frequency, MHz	Antenna		Azimuth, degrees*	Peak field strength(VBW=3 MHz)			Average field strength(VBW=10 Hz)				Verdict
	Polarization	Height, m		Measured, dB(μV/m)	Limit, dB(μV/m)	Margin, dB**	Measured, dB(μV/m)	Calculated, dB(μV/m)	Limit, dB(μV/m)	Margin, dB***	
Low carrier frequency											
All emissions were found at least 20 dB below the limit											Pass
Mid carrier frequency											
All emissions were found at least 20 dB below the limit											Pass
High carrier frequency											
All emissions were found at least 20 dB below the limit											Pass

*- EUT front panel refers to 0 degrees position of turntable.
 **- Margin = Measured field strength - specification limit.
 ***- Margin = Calculated field strength - specification limit,
 where Calculated field strength = Measured field strength + average factor.

Test specification:		Section 15.247(c), Radiated spurious emissions			
Test procedure:		FR Vol. 62, page 26243, Section 15.247(c) / ANSI C63.4, Section 13.1.4			
Test mode:	Compliance	Verdict:			
Date & Time:	6/28/2006 2:24:40 PM				
Temperature: 24 °C	Air Pressure: 1014 hPa	Relative Humidity: 50 %	Power Supply: 120 VAC		
Remarks: 802.11b/g					

Table 7.6.3 Field strength of spurious emissions below 1 GHz within restricted bands

INVESTIGATED FREQUENCY RANGE: 0.009 – 1000 MHz
TEST DISTANCE: 3 m
MODULATION: FSK / PSK / QAM
MODULATING SIGNAL: PRBS
BIT RATE: Mbps
DUTY CYCLE: 100 %
TRANSMITTER OUTPUT POWER SETTINGS: Maximum

RESOLUTION BANDWIDTH: 0.2 kHz (9 kHz – 150 kHz)
9.0 kHz (150 kHz – 30 MHz)
120 kHz (30 MHz – 1000 MHz)

VIDEO BANDWIDTH: > Resolution bandwidth
TEST ANTENNA TYPE: Active loop (9 kHz – 30 MHz)
Biconilog (30 MHz – 1000 MHz)

Frequency, MHz	Peak emission, dB(μV/m)	Quasi-peak			Antenna polarization	Antenna height, m	Turn-table position**, degrees	Verdict
		Measured emission, dB(μV/m)	Limit, dB(μV/m)	Margin, dB*				
Low carrier frequency								
243.4000	38.0	30.0	46.0	-16.0	V	1.0	240	PASS
266.5400	48.1	42.5	46.0	-3.5	H	1.0	206	
Mid carrier frequency								
266.5966	46.4	41.4	46.0	-4.6	H	1.0	185	PASS
High carrier frequency								
266.5966	46.4	41.4	46.0	-4.6	H	1.0	185	PASS

*- Margin = Measured emission - specification limit.
**- EUT front panel refer to 0 degrees position of turntable.

Table 7.6.4 Restricted bands

MHz	MHz	MHz	MHz	MHz	GHz
0.09 - 0.11	8.37625 - 8.38675	73 - 74.6	399.9 - 410	2690 - 2900	10.6 - 12.7
0.495 - 0.505	8.41425 - 8.41475	74.8 - 75.2	608 - 614	3260 - 3267	13.25 - 13.4
2.1735 - 2.1905	12.29 - 12.293	108 - 121.94	960 - 1240	3332 - 3339	14.47 - 14.5
4.125 - 4.128	12.51975 - 12.52025	123 - 138	1300 - 1427	3345.8 - 3358	15.35 - 16.2
4.17725 - 4.17775	12.57675 - 12.57725	149.9 - 150.05	1435 - 1626.5	3600 - 4400	17.7 - 21.4
4.20725 - 4.20775	13.36 - 13.41	156.52475 - 156.52525	1645.5 - 1646.5	4500 - 5150	22.01 - 23.12
6.215 - 6.218	16.42 - 16.423	156.7 - 156.9	1660 - 1710	5350 - 5460	23.6 - 24
6.26775 - 6.26825	16.69475 - 16.69525	162.0125 - 167.17	1718.8 - 1722.2	7250 - 7750	31.2 - 31.8
6.31175 - 6.31225	16.80425 - 16.80475	167.72 - 173.2	2200 - 2300	8025 - 8500	36.43 - 36.5
8.291 - 8.294	25.5 - 25.67	240 - 285	2310 - 2390	9000 - 9200	Above 38.6
8.362 - 8.366	37.5 - 38.25	322 - 335.4	2483.5 - 2500	9300 - 9500	

Test specification:	Section 15.247(c), Radiated spurious emissions		
Test procedure:	FR Vol. 62, page 26243, Section 15.247(c) / ANSI C63.4, Section 13.1.4		
Test mode:	Compliance	Verdict:	
Date & Time:	6/28/2006 2:24:40 PM		
Temperature: 24 °C	Air Pressure: 1014 hPa	Relative Humidity: 50 %	Power Supply: 120 VAC
Remarks: 802.11b/g			

Plot 7.6.1 Radiated emission measurements at the low carrier frequency

TEST SITE: Semi anechoic chamber
TEST DISTANCE: 3 m
ANTENNA POLARIZATION: Vertical

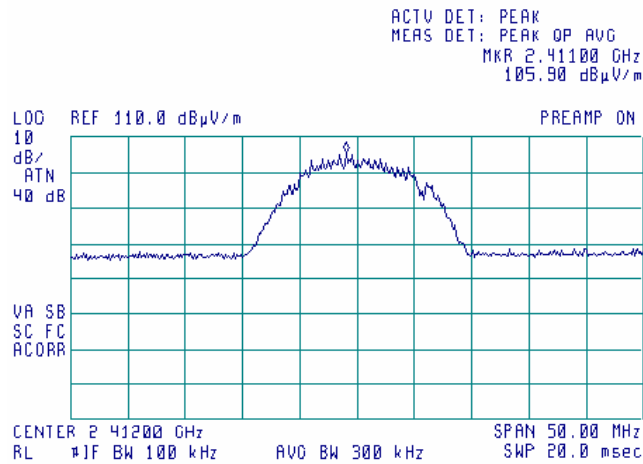

Plot 7.6.2 Radiated emission measurements at the low carrier frequency

TEST SITE: Semi anechoic chamber
TEST DISTANCE: 3 m
ANTENNA POLARIZATION: Horizontal

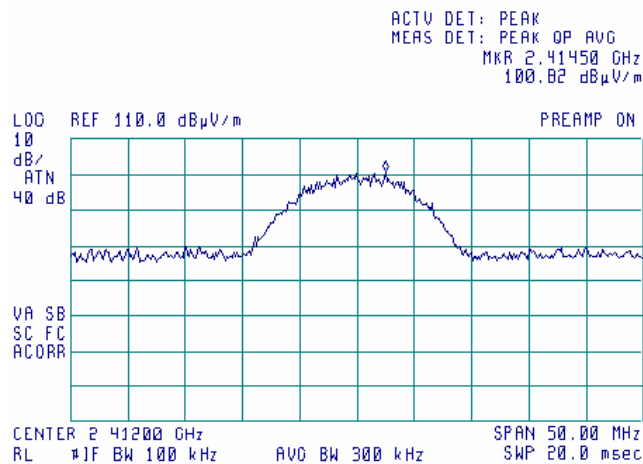

Test specification:	Section 15.247(c), Radiated spurious emissions		
Test procedure:	FR Vol. 62, page 26243, Section 15.247(c) / ANSI C63.4, Section 13.1.4		
Test mode:	Compliance	Verdict:	
Date & Time:	6/28/2006 2:24:40 PM		
Temperature: 24 °C	Air Pressure: 1014 hPa	Relative Humidity: 50 %	Power Supply: 120 VAC
Remarks: 802.11b/g			

Plot 7.6.3 Radiated emission measurements at the mid carrier frequency

TEST SITE: Semi anechoic chamber
TEST DISTANCE: 3 m
ANTENNA POLARIZATION: Vertical

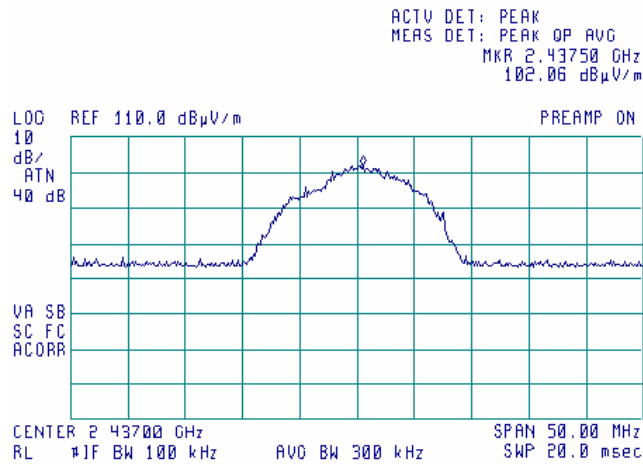

Plot 7.6.4 Radiated emission measurements at the mid carrier frequency

TEST SITE: Semi anechoic chamber
TEST DISTANCE: 3 m
ANTENNA POLARIZATION: Horizontal

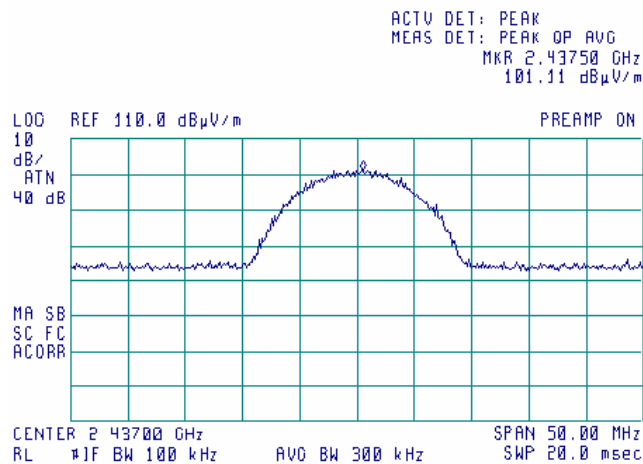

Test specification:	Section 15.247(c), Radiated spurious emissions		
Test procedure:	FR Vol. 62, page 26243, Section 15.247(c) / ANSI C63.4, Section 13.1.4		
Test mode:	Compliance	Verdict:	
Date & Time:	6/28/2006 2:24:40 PM		
Temperature: 24 °C	Air Pressure: 1014 hPa	Relative Humidity: 50 %	Power Supply: 120 VAC
Remarks: 802.11b/g			

Plot 7.6.5 Radiated emission measurements at the high carrier frequency

TEST SITE: Semi anechoic chamber
TEST DISTANCE: 3 m
ANTENNA POLARIZATION: Vertical

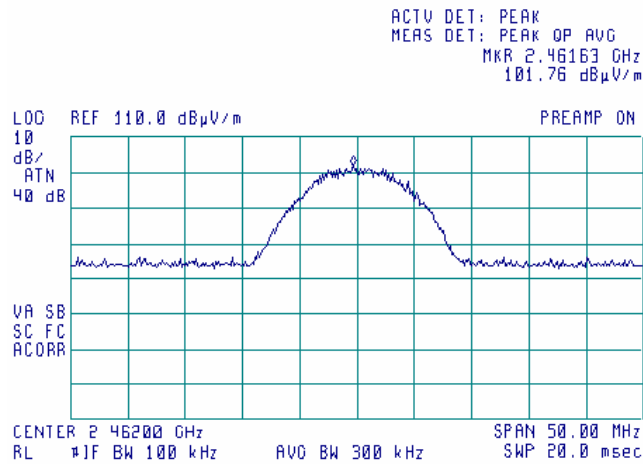

Plot 7.6.6 Radiated emission measurements at the high carrier frequency

TEST SITE: Semi anechoic chamber
TEST DISTANCE: 3 m
ANTENNA POLARIZATION: Horizontal

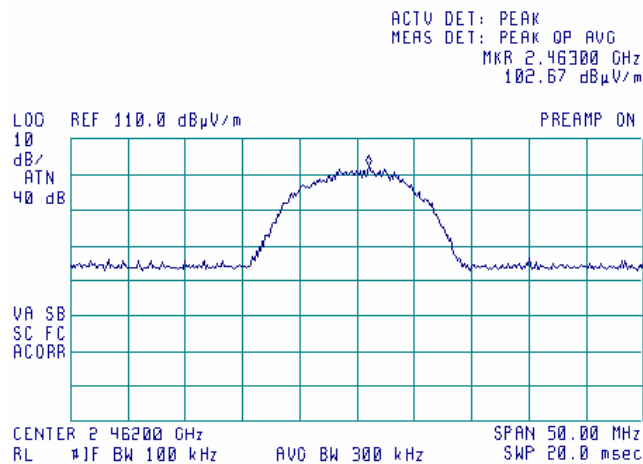

Test specification:	Section 15.247(c), Radiated spurious emissions		
Test procedure:	FR Vol. 62, page 26243, Section 15.247(c) / ANSI C63.4, Section 13.1.4		
Test mode:	Compliance	Verdict:	
Date & Time:	6/28/2006 2:24:40 PM		
Temperature: 24 °C	Air Pressure: 1014 hPa	Relative Humidity: 50 %	Power Supply: 120 VAC
Remarks: 802.11b/g			

Plot 7.6.7 Radiated emission measurements from 9 to 150 kHz at the low carrier frequency

TEST SITE: Anechoic chamber
 TEST DISTANCE: 3 m
 ANTENNA POLARIZATION: Vertical
 INPUTS: 802.11 b/g

19:02:06 JUL 02, 2006

ACTV DET: PEAK
 MEAS DET: PEAK OP AVG
 MKR 41.2 kHz
 66.58 dBμV/m

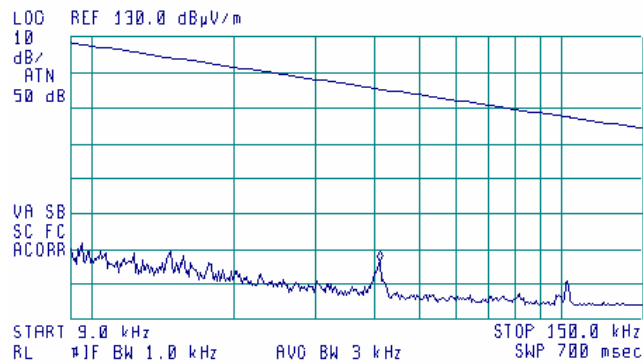

Plot 7.6.8 Radiated emission measurements from 9 to 150 kHz at the mid carrier frequency

TEST SITE: Anechoic chamber
 TEST DISTANCE: 3 m
 ANTENNA POLARIZATION: Vertical
 INPUTS: 802.11 b/g

19:05:50 JUL 02, 2006

ACTV DET: PEAK
 MEAS DET: PEAK OP AVG
 MKR 40.9 kHz
 65.26 dBμV/m

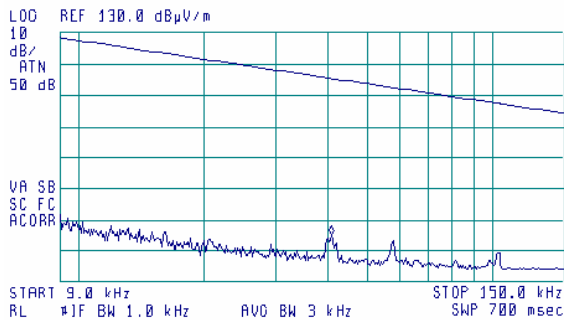

Test specification:	Section 15.247(c), Radiated spurious emissions		
Test procedure:	FR Vol. 62, page 26243, Section 15.247(c) / ANSI C63.4, Section 13.1.4		
Test mode:	Compliance	Verdict:	
Date & Time:	6/28/2006 2:24:40 PM		
Temperature: 24 °C	Air Pressure: 1014 hPa	Relative Humidity: 50 %	Power Supply: 120 VAC
Remarks: 802.11b/g			

Plot 7.6.9 Radiated emission measurements from 9 to 150 kHz at the high carrier frequency

TEST SITE: Anechoic chamber
TEST DISTANCE: 3 m
ANTENNA POLARIZATION: Vertical
INPUTS: 802.11 b/g

19:25:37 JUL 02, 2006

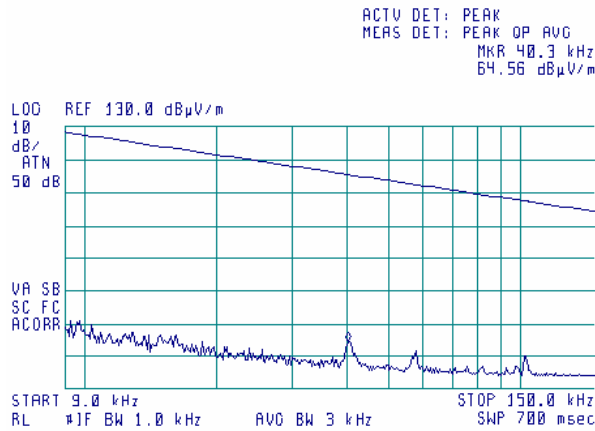

Plot 7.6.10 Radiated emission measurements from 0.15 to 30 MHz at the low carrier frequency

TEST SITE: Anechoic chamber
TEST DISTANCE: 3 m
ANTENNA POLARIZATION: Vertical
INPUTS: 802.11 b/g

18:51:30 JUL 02, 2006

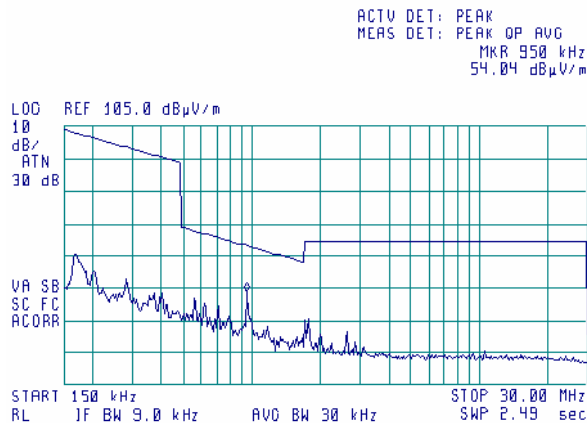

Note: frequency 0.950 MHz - outside restricted bands

Test specification:	Section 15.247(c), Radiated spurious emissions		
Test procedure:	FR Vol. 62, page 26243, Section 15.247(c) / ANSI C63.4, Section 13.1.4		
Test mode:	Compliance	Verdict:	
Date & Time:	6/28/2006 2:24:40 PM		
Temperature: 24 °C	Air Pressure: 1014 hPa	Relative Humidity: 50 %	Power Supply: 120 VAC
Remarks: 802.11b/g			

Plot 7.6.11 Radiated emission measurements from 0.15 to 30 MHz at the mid carrier frequency

TEST SITE: Anechoic chamber
 TEST DISTANCE: 3 m
 ANTENNA POLARIZATION: Vertical
 INPUTS: 802.11 b/g

19:13:42 JUL 02, 2006

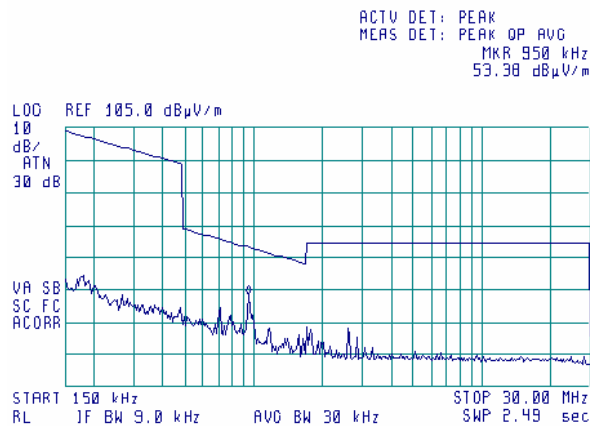

Note: frequency 0.950 MHz - outside restricted bands

Plot 7.6.12 Radiated emission measurements from 0.15 to 30 MHz at the high carrier frequency

TEST SITE: Anechoic chamber
 TEST DISTANCE: 3 m
 ANTENNA POLARIZATION: Vertical
 INPUTS: 802.11 b/g

19:16:25 JUL 02, 2006

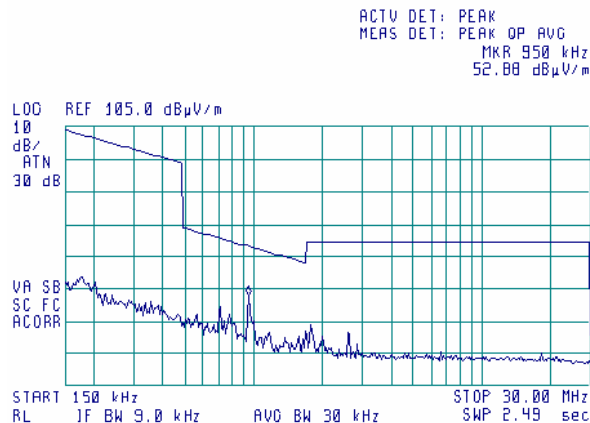

Note: frequency 0.950 MHz - outside restricted bands

Test specification:	Section 15.247(c), Radiated spurious emissions		
Test procedure:	FR Vol. 62, page 26243, Section 15.247(c) / ANSI C63.4, Section 13.1.4		
Test mode:	Compliance	Verdict:	
Date & Time:	6/28/2006 2:24:40 PM		
Temperature: 24 °C	Air Pressure: 1014 hPa	Relative Humidity: 50 %	Power Supply: 120 VAC
Remarks: 802.11b/g			

Plot 7.6.13 Radiated emission measurements from 30 to 1000 MHz at the low carrier frequency

TEST SITE: Anechoic chamber
 TEST DISTANCE: 3 m
 ANTENNA POLARIZATION: Vertical and Horizontal
 INPUTS: 802.11 b/g

21:40:43 JUL 02, 2006

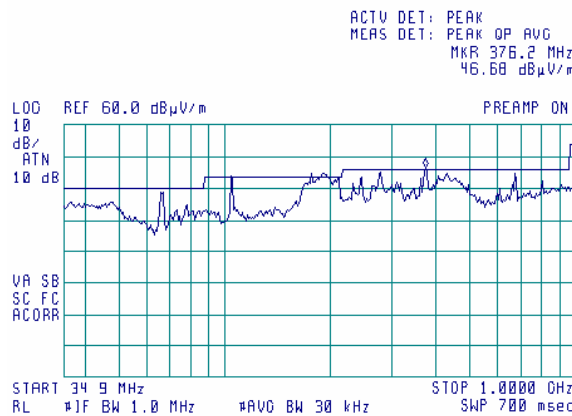

Note: frequencies 60.3600MHz, 105.1230 MHz, 198.7875 MHz , 366.5500 MHz, 663.0000 MHz- outside restricted bands

Plot 7.6.14 Radiated emission measurements from 30 to 1000 MHz at the mid carrier frequency

TEST SITE: Anechoic chamber
 TEST DISTANCE: 3 m
 ANTENNA POLARIZATION: Vertical and Horizontal
 INPUTS: 802.11 b/g

23:18:26 JUL 02, 2006

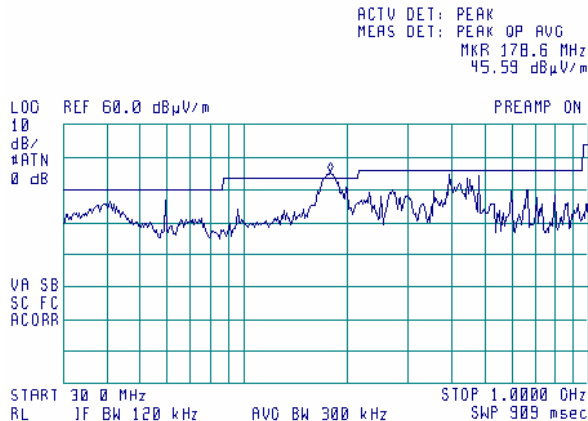

Note: frequencies 60.3600MHz, 173.4800 MHz, 398.5250 MHz, 448.0076 MHz, 480.0090 MHz - outside restricted bands

Test specification:	Section 15.247(c), Radiated spurious emissions		
Test procedure:	FR Vol. 62, page 26243, Section 15.247(c) / ANSI C63.4, Section 13.1.4		
Test mode:	Compliance	Verdict:	
Date & Time:	6/28/2006 2:24:40 PM		
Temperature: 24 °C	Air Pressure: 1014 hPa	Relative Humidity: 50 %	Power Supply: 120 VAC
Remarks: 802.11b/g			

Plot 7.6.15 Radiated emission measurements from 30 to 1000 MHz at the high carrier frequency

TEST SITE: Anechoic chamber
 TEST DISTANCE: 3 m
 ANTENNA POLARIZATION: Vertical and Horizontal
 INPUTS: 802.11 b/g

20:10:58 JUL 02, 2006

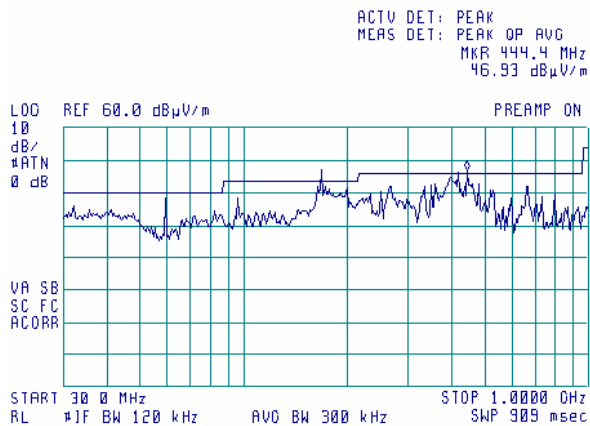

Note: frequencies 60.3600MHz, 166.6028 MHz, 391.2424 MHz, 416.8125 MHz, 447.9982 MHz, 480.8240 MHz - outside restricted bands

Test specification:	Section 15.247(c), Radiated spurious emissions		
Test procedure:	FR Vol. 62, page 26243, Section 15.247(c) / ANSI C63.4, Section 13.1.4		
Test mode:	Compliance	Verdict:	
Date & Time:	6/28/2006 2:24:40 PM		
Temperature: 24 °C	Air Pressure: 1014 hPa	Relative Humidity: 50 %	Power Supply: 120 VAC
Remarks: 802.11b/g			

Plot 7.6.16 Radiated emission measurements from 1000 to 2350 MHz at the low carrier frequency

TEST SITE: Anechoic chamber
 TEST DISTANCE: 3 m
 ANTENNA POLARIZATION: Vertical and Horizontal
 INPUTS: 802.11 b/g
 DETECTOR: Peak

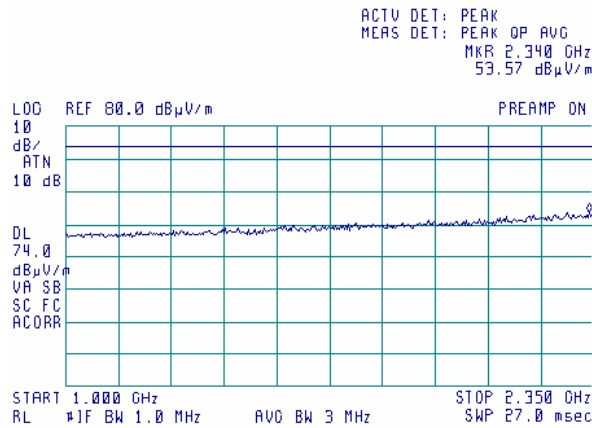

Plot 7.6.17 Radiated emission measurements from 1000 to 2350 MHz at the low carrier frequency

TEST SITE: Anechoic chamber
 TEST DISTANCE: 3 m
 ANTENNA POLARIZATION: Vertical and Horizontal
 INPUTS: 802.11 b/g
 DETECTOR: Average

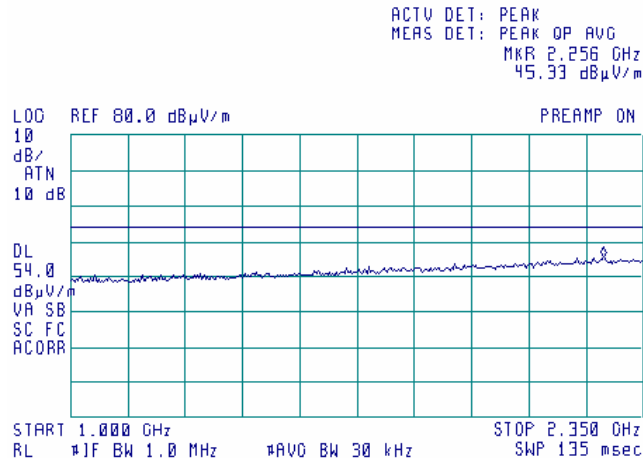

Test specification:	Section 15.247(c), Radiated spurious emissions		
Test procedure:	FR Vol. 62, page 26243, Section 15.247(c) / ANSI C63.4, Section 13.1.4		
Test mode:	Compliance	Verdict:	
Date & Time:	6/28/2006 2:24:40 PM		
Temperature: 24 °C	Air Pressure: 1014 hPa	Relative Humidity: 50 %	Power Supply: 120 VAC
Remarks: 802.11b/g			

Plot 7.6.18 Radiated emission measurements from 2350 to 2390 MHz at the low carrier frequency

TEST SITE: Anechoic chamber
 TEST DISTANCE: 3 m
 ANTENNA POLARIZATION: Vertical and Horizontal
 INPUTS: 802.11 b/g
 DETECTOR: Peak

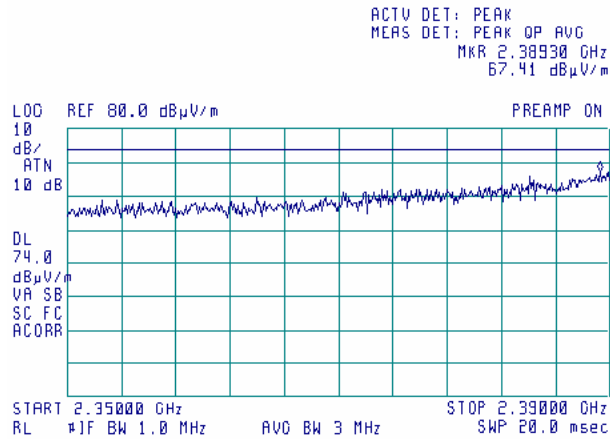

Plot 7.6.19 Radiated emission measurements from 2350 to 2390 MHz at the low carrier frequency

TEST SITE: Anechoic chamber
 TEST DISTANCE: 3 m
 ANTENNA POLARIZATION: Vertical and Horizontal
 INPUTS: 802.11 b/g
 DETECTOR: Average

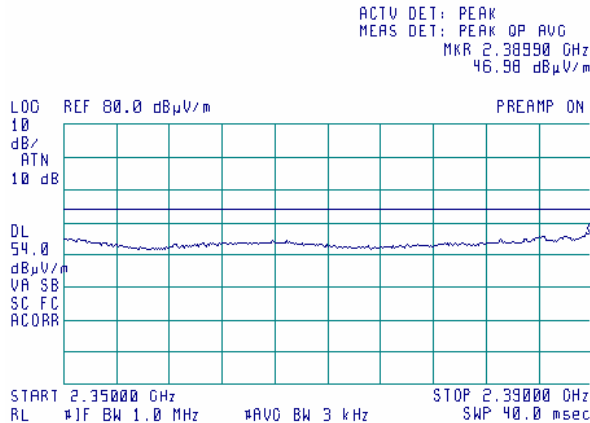

Test specification:	Section 15.247(c), Radiated spurious emissions		
Test procedure:	FR Vol. 62, page 26243, Section 15.247(c) / ANSI C63.4, Section 13.1.4		
Test mode:	Compliance	Verdict:	
Date & Time:	6/28/2006 2:24:40 PM		
Temperature: 24 °C	Air Pressure: 1014 hPa	Relative Humidity: 50 %	Power Supply: 120 VAC
Remarks: 802.11b/g			

Plot 7.6.20 Radiated emission measurements from 1000 to 2390 MHz at the mid carrier frequency

TEST SITE: Anechoic chamber
 TEST DISTANCE: 3 m
 ANTENNA POLARIZATION: Vertical and Horizontal
 INPUTS: 802.11 b/g
 DETECTOR: Peak

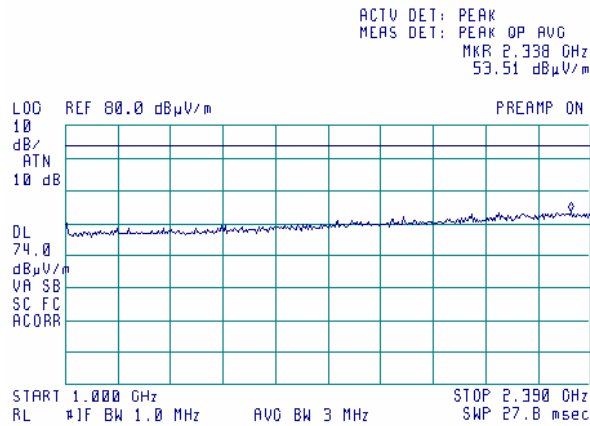

Plot 7.6.21 Radiated emission measurements from 1000 to 2390 MHz at the mid carrier frequency

TEST SITE: Anechoic chamber
 TEST DISTANCE: 3 m
 ANTENNA POLARIZATION: Vertical and Horizontal
 INPUTS: 802.11 b/g
 DETECTOR: Average

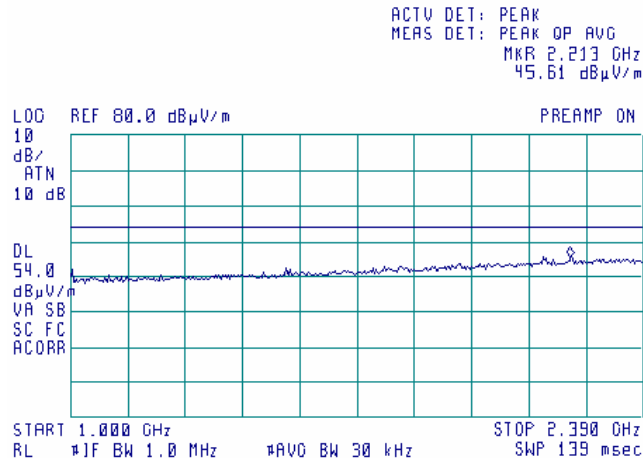

Test specification:	Section 15.247(c), Radiated spurious emissions		
Test procedure:	FR Vol. 62, page 26243, Section 15.247(c) / ANSI C63.4, Section 13.1.4		
Test mode:	Compliance	Verdict:	
Date & Time:	6/28/2006 2:24:40 PM		
Temperature: 24 °C	Air Pressure: 1014 hPa	Relative Humidity: 50 %	Power Supply: 120 VAC
Remarks: 802.11b/g			

Plot 7.6.22 Radiated emission measurements from 1000 to 2390 MHz at the high carrier frequency

TEST SITE: Anechoic chamber
 TEST DISTANCE: 3 m
 ANTENNA POLARIZATION: Vertical and Horizontal
 INPUTS: 802.11 b/g
 DETECTOR: Peak

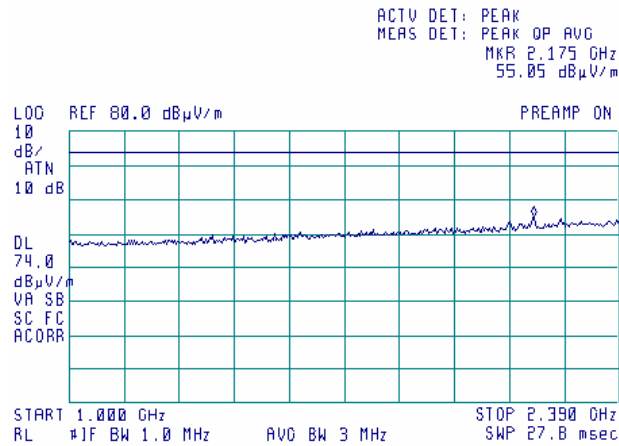

Plot 7.6.23 Radiated emission measurements from 1000 to 2390 MHz at the high carrier frequency

TEST SITE: Anechoic chamber
 TEST DISTANCE: 3 m
 ANTENNA POLARIZATION: Vertical and Horizontal
 INPUTS: 802.11 b/g
 DETECTOR: Average

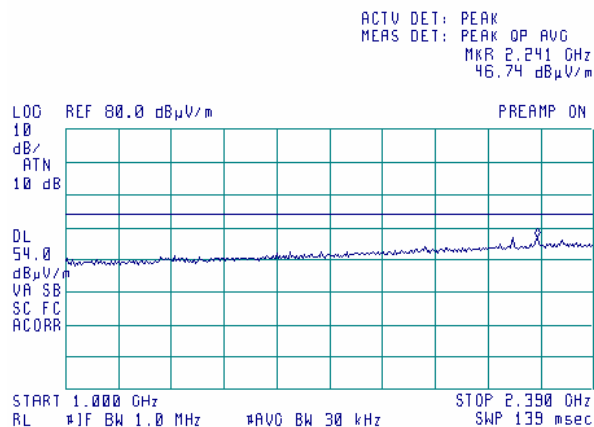

Test specification:	Section 15.247(c), Radiated spurious emissions		
Test procedure:	FR Vol. 62, page 26243, Section 15.247(c) / ANSI C63.4, Section 13.1.4		
Test mode:	Compliance	Verdict:	
Date & Time:	6/28/2006 2:24:40 PM		
Temperature: 24 °C	Air Pressure: 1014 hPa	Relative Humidity: 50 %	Power Supply: 120 VAC
Remarks: 802.11b/g			

Plot 7.6.24 Radiated emission measurements from 2483.5 to 2500 MHz at the low carrier frequency

TEST SITE: Anechoic chamber
 TEST DISTANCE: 3 m
 ANTENNA POLARIZATION: Vertical and Horizontal
 INPUTS: 802.11 b/g
 DETECTOR: Peak

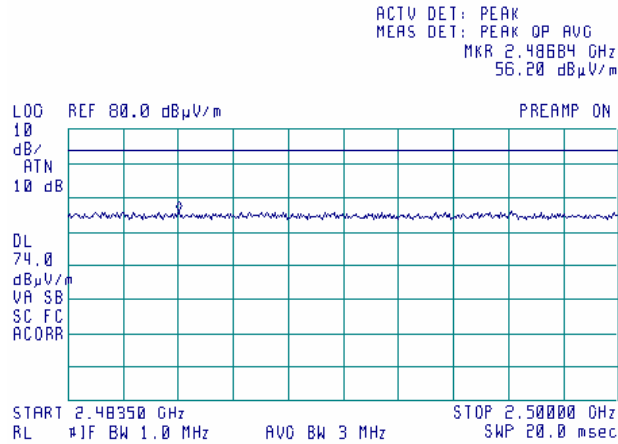

Plot 7.6.25 Radiated emission measurements from 2483.5 to 2500 MHz at the low carrier frequency

TEST SITE: Anechoic chamber
 TEST DISTANCE: 3 m
 ANTENNA POLARIZATION: Vertical and Horizontal
 INPUTS: 802.11 b/g
 DETECTOR: Average

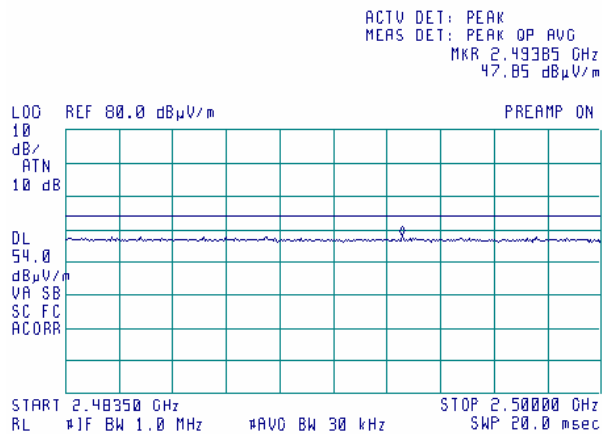

Test specification:	Section 15.247(c), Radiated spurious emissions		
Test procedure:	FR Vol. 62, page 26243, Section 15.247(c) / ANSI C63.4, Section 13.1.4		
Test mode:	Compliance	Verdict:	
Date & Time:	6/28/2006 2:24:40 PM		
Temperature: 24 °C	Air Pressure: 1014 hPa	Relative Humidity: 50 %	Power Supply: 120 VAC
Remarks: 802.11b/g			

Plot 7.6.26 Radiated emission measurements from 2483.5 to 2500 MHz at the mid carrier frequency

TEST SITE: Anechoic chamber
 TEST DISTANCE: 3 m
 ANTENNA POLARIZATION: Vertical and Horizontal
 INPUTS: 802.11 b/g
 DETECTOR: Peak

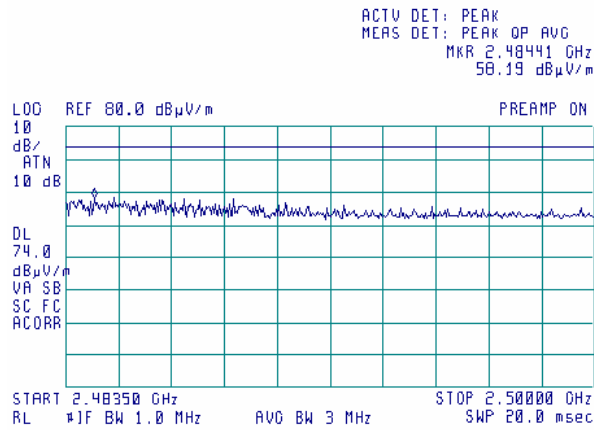

Plot 7.6.27 Radiated emission measurements from 2483.5 to 2500 MHz at the mid carrier frequency

TEST SITE: Anechoic chamber
 TEST DISTANCE: 3 m
 ANTENNA POLARIZATION: Vertical and Horizontal
 INPUTS: 802.11 b/g
 DETECTOR: Average

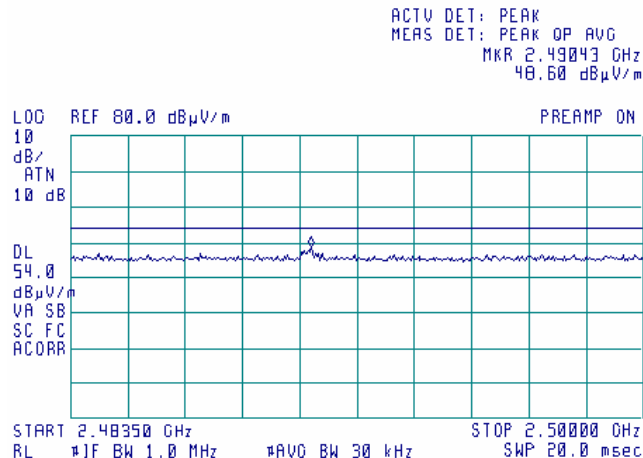

Test specification:	Section 15.247(c), Radiated spurious emissions		
Test procedure:	FR Vol. 62, page 26243, Section 15.247(c) / ANSI C63.4, Section 13.1.4		
Test mode:	Compliance	Verdict:	
Date & Time:	6/28/2006 2:24:40 PM		
Temperature: 24 °C	Air Pressure: 1014 hPa	Relative Humidity: 50 %	Power Supply: 120 VAC
Remarks: 802.11b/g			

Plot 7.6.28 Radiated emission measurements from 2483.5 to 2500 MHz at the high carrier frequency

TEST SITE: Anechoic chamber
 TEST DISTANCE: 3 m
 ANTENNA POLARIZATION: Vertical and Horizontal
 INPUTS: 802.11 b/g
 DETECTOR: Peak

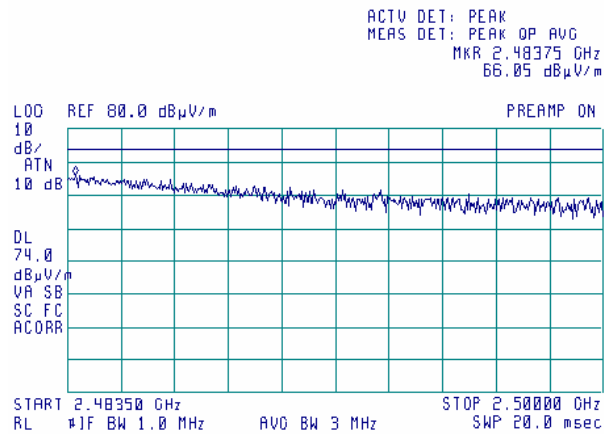

Plot 7.6.29 Radiated emission measurements from 2483.5 to 2500 MHz at the high carrier frequency

TEST SITE: Anechoic chamber
 TEST DISTANCE: 3 m
 ANTENNA POLARIZATION: Vertical and Horizontal
 INPUTS: 802.11 b/g
 DETECTOR: Average

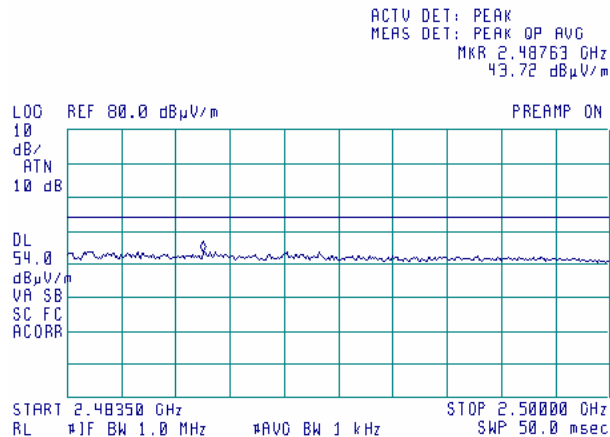

Test specification:	Section 15.247(c), Radiated spurious emissions		
Test procedure:	FR Vol. 62, page 26243, Section 15.247(c) / ANSI C63.4, Section 13.1.4		
Test mode:	Compliance	Verdict:	
Date & Time:	6/28/2006 2:24:40 PM		
Temperature: 24 °C	Air Pressure: 1014 hPa	Relative Humidity: 50 %	Power Supply: 120 VAC
Remarks: 802.11b/g			

Plot 7.6.30 Radiated emission measurements from 2500 to 2900 MHz at the low carrier frequency

TEST SITE: Semi Anechoic chamber
 TEST DISTANCE: 3 m
 ANTENNA POLARIZATION: Vertical and Horizontal
 INPUTS: 802.11 b/g
 DETECTOR: Peak

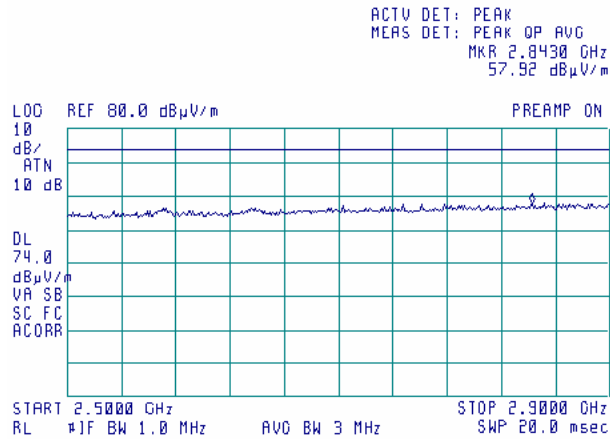

Plot 7.6.31 Radiated emission measurements from 2500 to 2900 MHz at the low carrier frequency

TEST SITE: Semi Anechoic chamber
 TEST DISTANCE: 3 m
 ANTENNA POLARIZATION: Vertical and Horizontal
 INPUTS: 802.11 b/g
 DETECTOR: Average

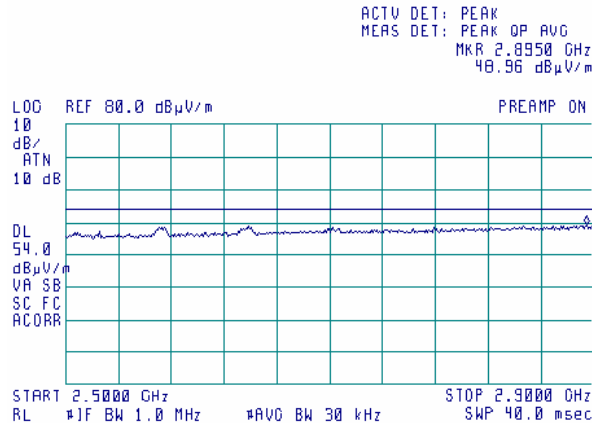

Test specification:	Section 15.247(c), Radiated spurious emissions		
Test procedure:	FR Vol. 62, page 26243, Section 15.247(c) / ANSI C63.4, Section 13.1.4		
Test mode:	Compliance	Verdict:	
Date & Time:	6/28/2006 2:24:40 PM		
Temperature: 24 °C	Air Pressure: 1014 hPa	Relative Humidity: 50 %	Power Supply: 120 VAC
Remarks: 802.11b/g			

Plot 7.6.32 Radiated emission measurements from 2500 to 2900 MHz at the mid carrier frequency

TEST SITE: Semi Anechoic chamber
 TEST DISTANCE: 3 m
 ANTENNA POLARIZATION: Vertical and Horizontal
 INPUTS: 802.11 b/g
 DETECTOR: Peak

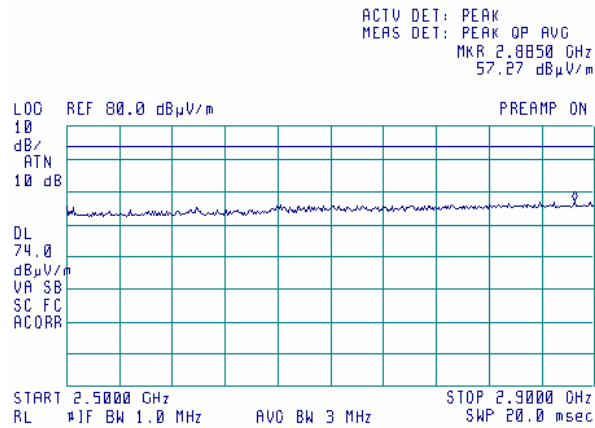

Plot 7.6.33 Radiated emission measurements from 2500 to 2900 MHz at the mid carrier frequency

TEST SITE: Semi Anechoic chamber
 TEST DISTANCE: 3 m
 ANTENNA POLARIZATION: Vertical and Horizontal
 INPUTS: 802.11 b/g
 DETECTOR: Average

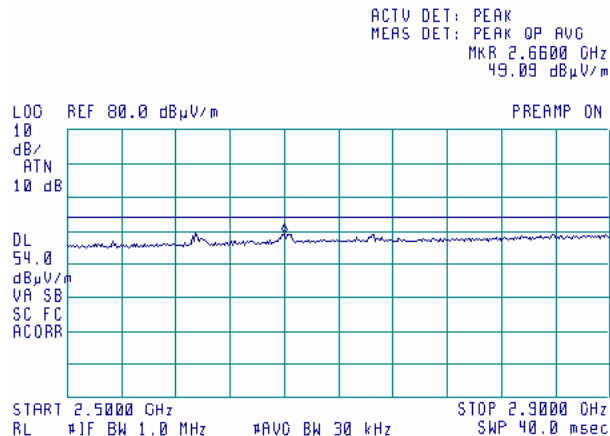

Test specification:	Section 15.247(c), Radiated spurious emissions		
Test procedure:	FR Vol. 62, page 26243, Section 15.247(c) / ANSI C63.4, Section 13.1.4		
Test mode:	Compliance	Verdict:	
Date & Time:	6/28/2006 2:24:40 PM		
Temperature: 24 °C	Air Pressure: 1014 hPa	Relative Humidity: 50 %	Power Supply: 120 VAC
Remarks: 802.11b/g			

Plot 7.6.34 Radiated emission measurements from 2500 to 2900 MHz at the high carrier frequency

TEST SITE: Semi Anechoic chamber
 TEST DISTANCE: 3 m
 ANTENNA POLARIZATION: Vertical and Horizontal
 INPUTS: 802.11 b/g
 DETECTOR: Peak

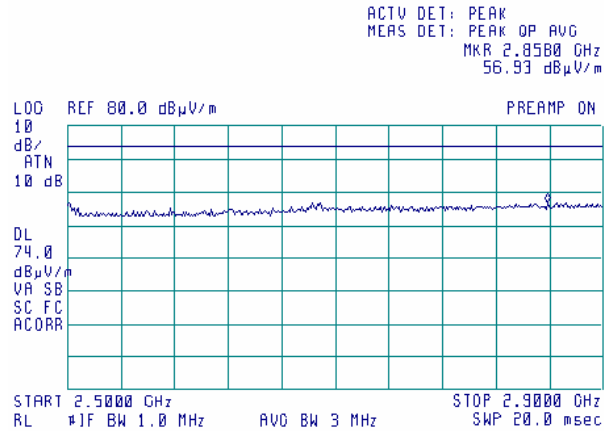

Plot 7.6.35 Radiated emission measurements from 2500 to 2900 MHz at the high carrier frequency

TEST SITE: Semi Anechoic chamber
 TEST DISTANCE: 3 m
 ANTENNA POLARIZATION: Vertical and Horizontal
 INPUTS: 802.11 b/g
 DETECTOR: Average

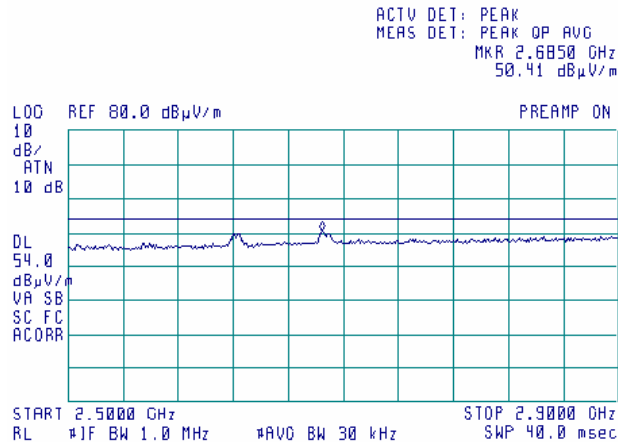

frequencies 2.621 and 2.685GHz within restricted bands

Test specification:	Section 15.247(c), Radiated spurious emissions		
Test procedure:	FR Vol. 62, page 26243, Section 15.247(c) / ANSI C63.4, Section 13.1.4		
Test mode:	Compliance	Verdict:	
Date & Time:	6/28/2006 2:24:40 PM		
Temperature: 24 °C	Air Pressure: 1014 hPa	Relative Humidity: 50 %	Power Supply: 120 VAC
Remarks: 802.11b/g			

Plot 7.6.36 Radiated emission measurements from 2500 to 2900 MHz at the high carrier frequency

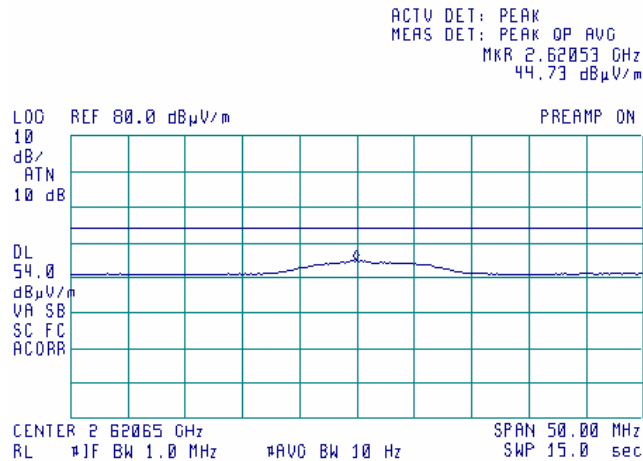
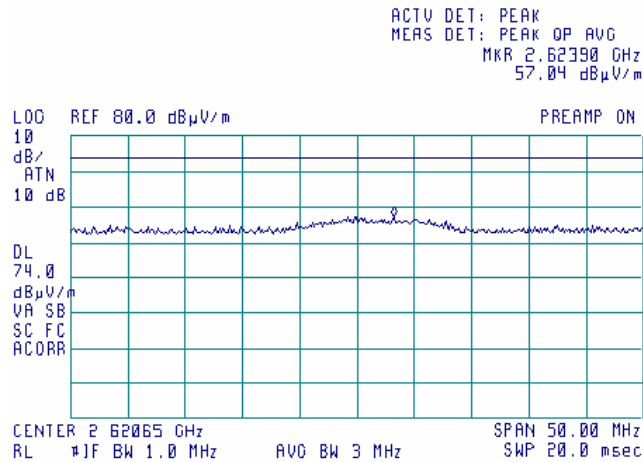

Test specification:	Section 15.247(c), Radiated spurious emissions		
Test procedure:	FR Vol. 62, page 26243, Section 15.247(c) / ANSI C63.4, Section 13.1.4		
Test mode:	Compliance	Verdict:	
Date & Time:	6/28/2006 2:24:40 PM		
Temperature: 24 °C	Air Pressure: 1014 hPa	Relative Humidity: 50 %	Power Supply: 120 VAC
Remarks: 802.11b/g			

Plot 7.6.37 Radiated emission measurements from 2500 to 2900 MHz at the high carrier frequency

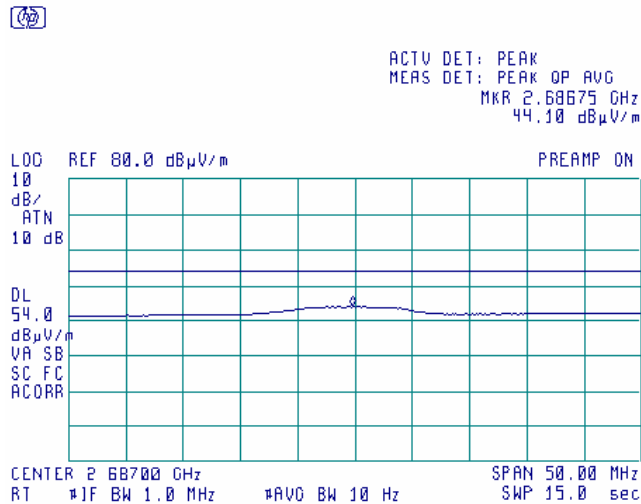
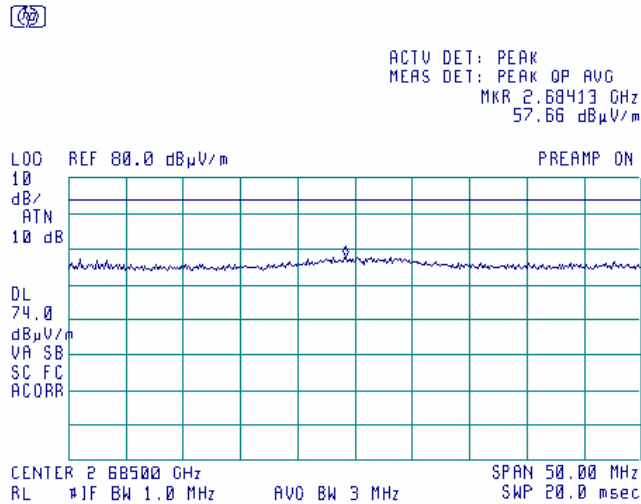

Test specification:	Section 15.247(c), Radiated spurious emissions		
Test procedure:	FR Vol. 62, page 26243, Section 15.247(c) / ANSI C63.4, Section 13.1.4		
Test mode:	Compliance	Verdict:	
Date & Time:	6/28/2006 2:24:40 PM		
Temperature: 24 °C	Air Pressure: 1014 hPa	Relative Humidity: 50 %	Power Supply: 120 VAC
Remarks: 802.11b/g			

Plot 7.6.38 Radiated emission measurements from 2900 to 4000 MHz at the low carrier frequency

TEST SITE: Semi Anechoic chamber
 TEST DISTANCE: 3 m
 ANTENNA POLARIZATION: Vertical and Horizontal
 INPUTS: 802.11 b/g
 DETECTOR: Peak

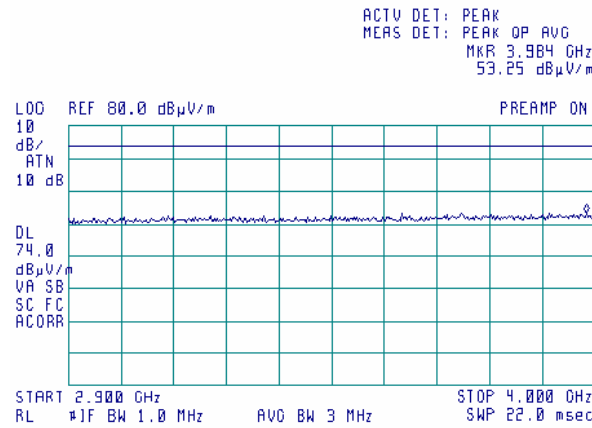

Plot 7.6.39 Radiated emission measurements from 2900 to 4000 MHz at the low carrier frequency

TEST SITE: Semi Anechoic chamber
 TEST DISTANCE: 3 m
 ANTENNA POLARIZATION: Vertical and Horizontal
 INPUTS: 802.11 b/g
 DETECTOR: Average

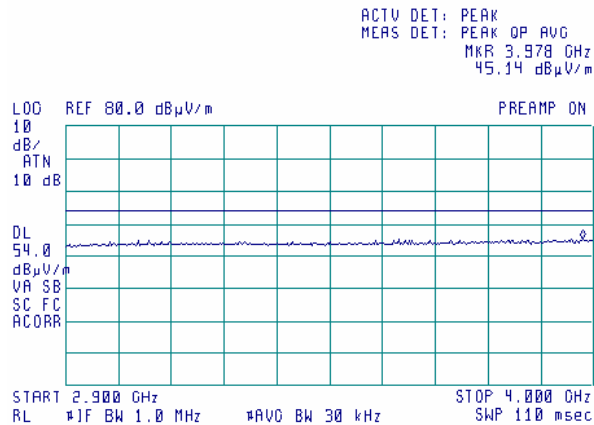

Test specification:	Section 15.247(c), Radiated spurious emissions		
Test procedure:	FR Vol. 62, page 26243, Section 15.247(c) / ANSI C63.4, Section 13.1.4		
Test mode:	Compliance	Verdict:	
Date & Time:	6/28/2006 2:24:40 PM		
Temperature: 24 °C	Air Pressure: 1014 hPa	Relative Humidity: 50 %	Power Supply: 120 VAC
Remarks: 802.11b/g			

Plot 7.6.40 Radiated emission measurements from 2900 to 4000 MHz at the mid carrier frequency

TEST SITE: Semi Anechoic chamber
 TEST DISTANCE: 3 m
 ANTENNA POLARIZATION: Vertical and Horizontal
 INPUTS: 802.11 b/g
 DETECTOR: Peak

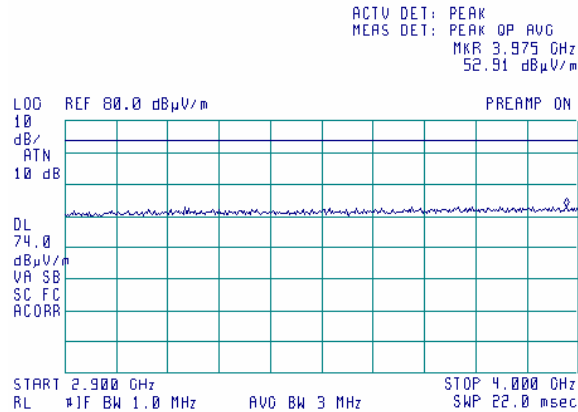

Plot 7.6.41 Radiated emission measurements from 2900 to 4000 MHz at the mid carrier frequency

TEST SITE: Semi Anechoic chamber
 TEST DISTANCE: 3 m
 ANTENNA POLARIZATION: Vertical and Horizontal
 INPUTS: 802.11 b/g
 DETECTOR: Average

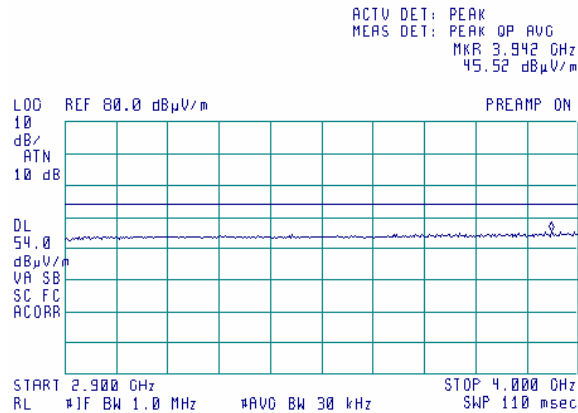

Test specification:	Section 15.247(c), Radiated spurious emissions		
Test procedure:	FR Vol. 62, page 26243, Section 15.247(c) / ANSI C63.4, Section 13.1.4		
Test mode:	Compliance	Verdict:	
Date & Time:	6/28/2006 2:24:40 PM		
Temperature: 24 °C	Air Pressure: 1014 hPa	Relative Humidity: 50 %	Power Supply: 120 VAC
Remarks: 802.11b/g			

Plot 7.6.42 Radiated emission measurements from 2900 to 4000 MHz at the high carrier frequency

TEST SITE: Semi Anechoic chamber
 TEST DISTANCE: 3 m
 ANTENNA POLARIZATION: Vertical and Horizontal
 INPUTS: 802.11 b/g
 DETECTOR: Peak

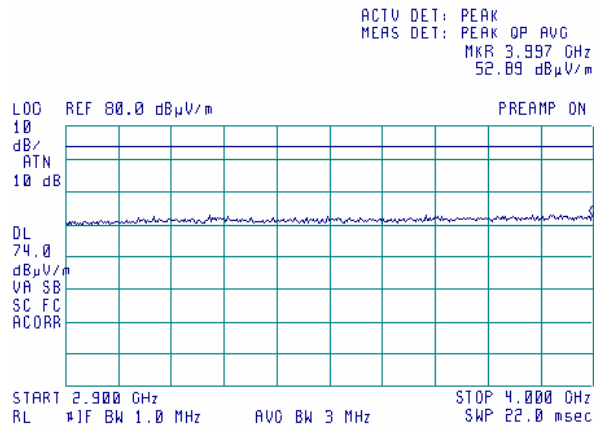

Plot 7.6.43 Radiated emission measurements from 2900 to 4000 MHz at the high carrier frequency

TEST SITE: Semi Anechoic chamber
 TEST DISTANCE: 3 m
 ANTENNA POLARIZATION: Vertical and Horizontal
 INPUTS: 802.11 b/g
 DETECTOR: Average

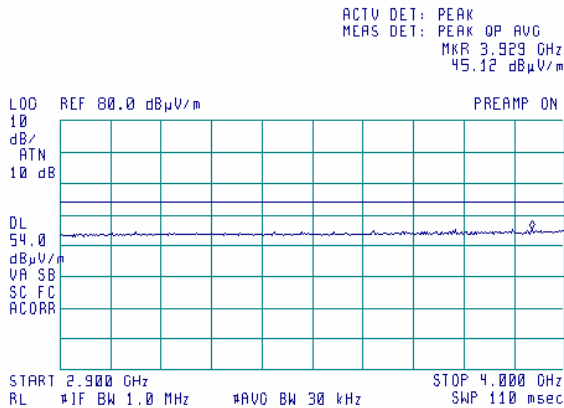

Test specification:	Section 15.247(c), Radiated spurious emissions		
Test procedure:	FR Vol. 62, page 26243, Section 15.247(c) / ANSI C63.4, Section 13.1.4		
Test mode:	Compliance	Verdict:	
Date & Time:	6/28/2006 2:24:40 PM		
Temperature: 24 °C	Air Pressure: 1014 hPa	Relative Humidity: 50 %	Power Supply: 120 VAC
Remarks: 802.11b/g			

Plot 7.6.44 Radiated emission measurements from 4000 to 5150 MHz at the low carrier frequency

TEST SITE: Anechoic chamber
TEST DISTANCE: 3 m
ANTENNA POLARIZATION: Vertical and Horizontal
INPUTS: 802.11 b/g

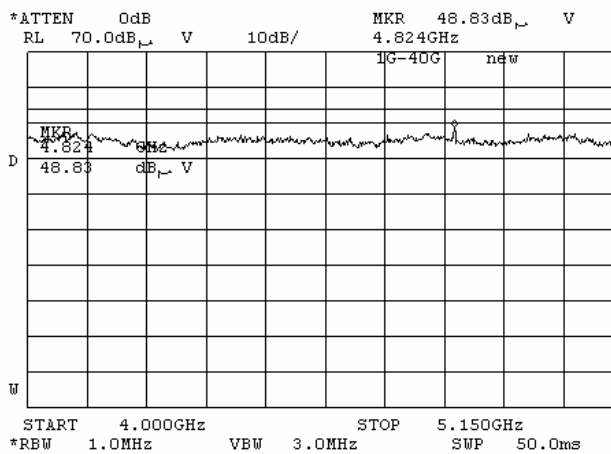

Plot 7.6.45 Radiated emission measurements from 4000 to 5150 MHz at the mid carrier frequency

TEST SITE: Anechoic chamber
TEST DISTANCE: 3 m
ANTENNA POLARIZATION: Vertical and Horizontal
INPUTS: 802.11 b/g

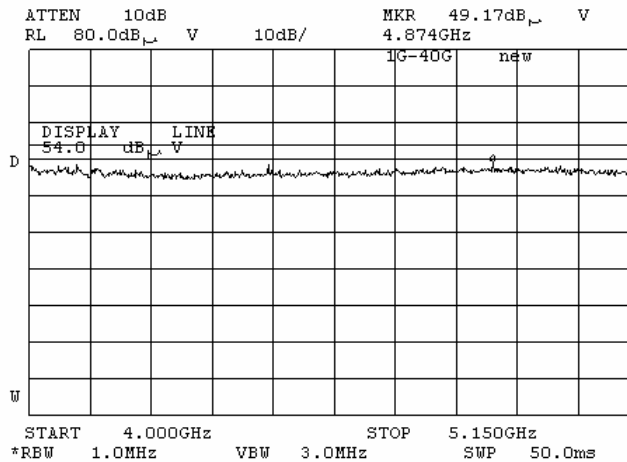

Test specification:	Section 15.247(c), Radiated spurious emissions		
Test procedure:	FR Vol. 62, page 26243, Section 15.247(c) / ANSI C63.4, Section 13.1.4		
Test mode:	Compliance	Verdict:	
Date & Time:	6/28/2006 2:24:40 PM		
Temperature: 24 °C	Air Pressure: 1014 hPa	Relative Humidity: 50 %	Power Supply: 120 VAC
Remarks: 802.11b/g			

Plot 7.6.46 Radiated emission measurements from 4000 to 5150 MHz at the high carrier frequency

TEST SITE: Anechoic chamber
 TEST DISTANCE: 3 m
 ANTENNA POLARIZATION: Vertical and Horizontal
 INPUTS: 802.11 b/g

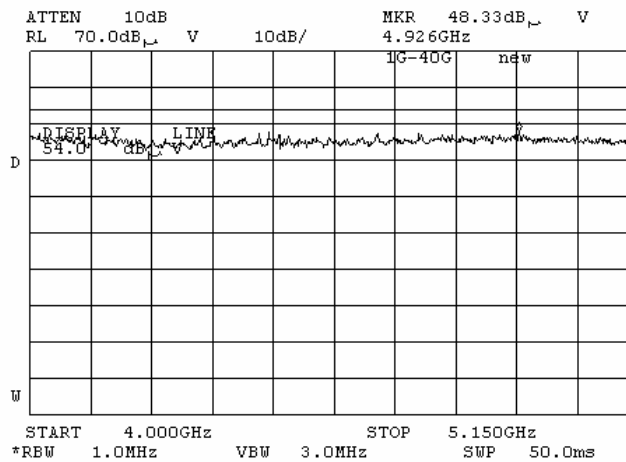

Plot 7.6.47 Radiated emission measurements from 5350 to 5460 MHz at the low carrier frequency

TEST SITE: Anechoic chamber
 TEST DISTANCE: 3 m
 ANTENNA POLARIZATION: Vertical and Horizontal
 INPUTS: 802.11 b/g

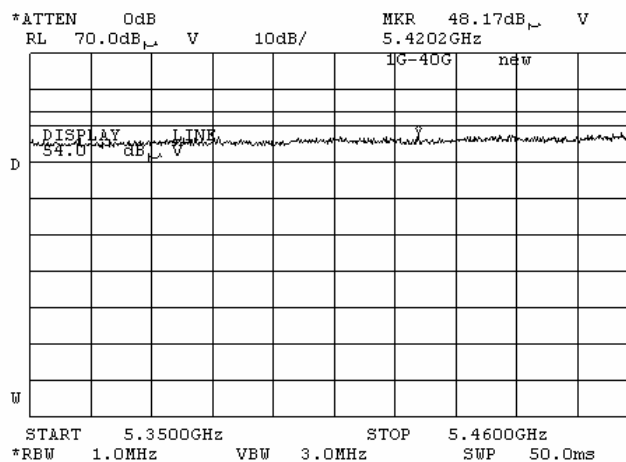

Test specification:	Section 15.247(c), Radiated spurious emissions		
Test procedure:	FR Vol. 62, page 26243, Section 15.247(c) / ANSI C63.4, Section 13.1.4		
Test mode:	Compliance	Verdict:	
Date & Time:	6/28/2006 2:24:40 PM		
Temperature: 24 °C	Air Pressure: 1014 hPa	Relative Humidity: 50 %	Power Supply: 120 VAC
Remarks: 802.11b/g			

Plot 7.6.48 Radiated emission measurements from 5350 to 5460 MHz at the mid carrier frequency

TEST SITE: Anechoic chamber
 TEST DISTANCE: 3 m
 ANTENNA POLARIZATION: Vertical and Horizontal
 INPUTS: 802.11 b/g

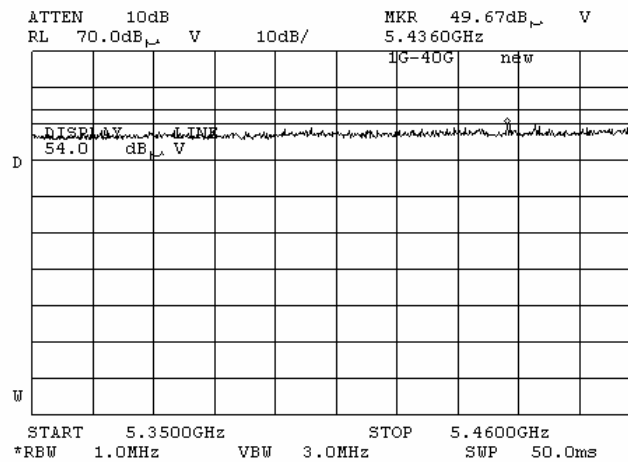

Plot 7.6.49 Radiated emission measurements from 5350 to 5460 MHz at the high carrier frequency

TEST SITE: Anechoic chamber
 TEST DISTANCE: 3 m
 ANTENNA POLARIZATION: Vertical and Horizontal
 INPUTS: 802.11 b/g

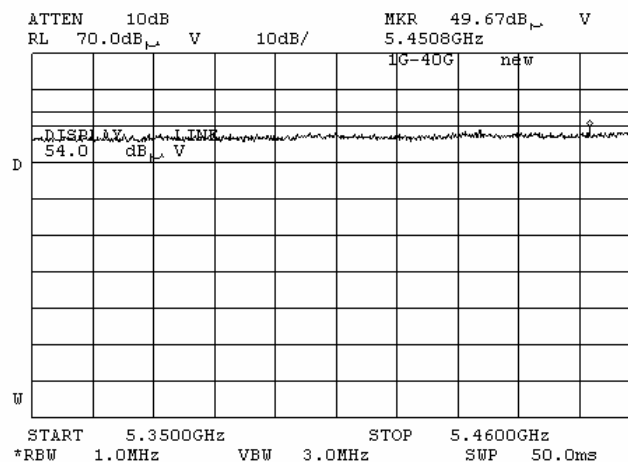

Test specification:	Section 15.247(c), Radiated spurious emissions		
Test procedure:	FR Vol. 62, page 26243, Section 15.247(c) / ANSI C63.4, Section 13.1.4		
Test mode:	Compliance	Verdict:	
Date & Time:	6/28/2006 2:24:40 PM		
Temperature: 24 °C	Air Pressure: 1014 hPa	Relative Humidity: 50 %	Power Supply: 120 VAC
Remarks: 802.11b/g			

Plot 7.6.50 Radiated emission measurements from 5.46 to 8.0 GHz at the low carrier frequency

TEST SITE: Anechoic chamber
 TEST DISTANCE: 3 m
 ANTENNA POLARIZATION: Vertical and Horizontal
 INPUTS: 802.11 b/g
 DETECTOR: Peak

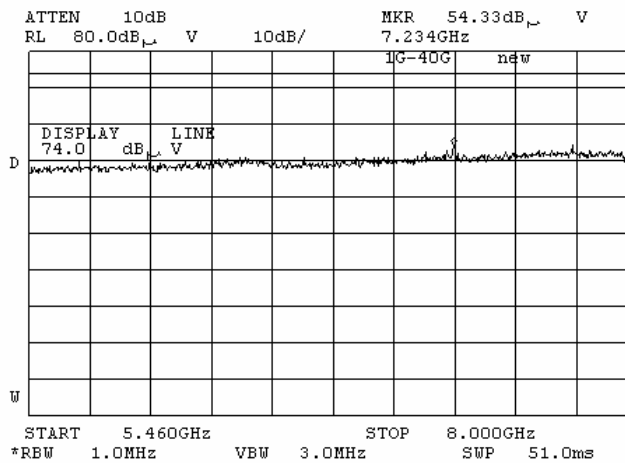

Plot 7.6.51 Radiated emission measurements from 5.46 to 8.0 GHz at the low carrier frequency

TEST SITE: Anechoic chamber
 TEST DISTANCE: 3 m
 ANTENNA POLARIZATION: Vertical and Horizontal
 INPUTS: 802.11 b/g
 DETECTOR: Average

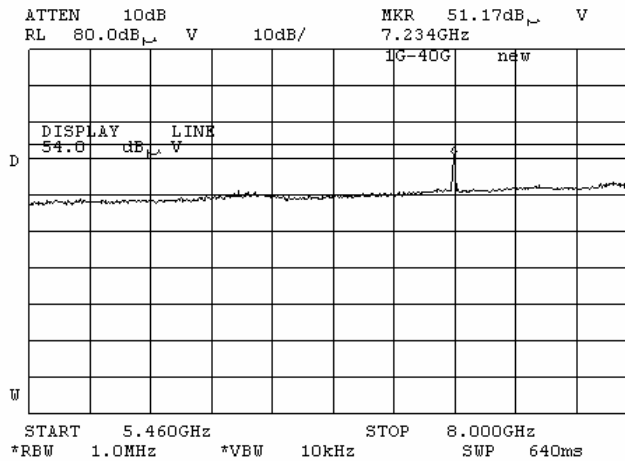

Test specification:	Section 15.247(c), Radiated spurious emissions		
Test procedure:	FR Vol. 62, page 26243, Section 15.247(c) / ANSI C63.4, Section 13.1.4		
Test mode:	Compliance	Verdict:	
Date & Time:	6/28/2006 2:24:40 PM		
Temperature: 24 °C	Air Pressure: 1014 hPa	Relative Humidity: 50 %	Power Supply: 120 VAC
Remarks: 802.11b/g			

Plot 7.6.52 Radiated emission measurements from 5.46 to 8.0 GHz at the mid carrier frequency

TEST SITE: Anechoic chamber
 TEST DISTANCE: 3 m
 ANTENNA POLARIZATION: Vertical and Horizontal
 INPUTS: 802.11 b/g
 DETECTOR: Peak

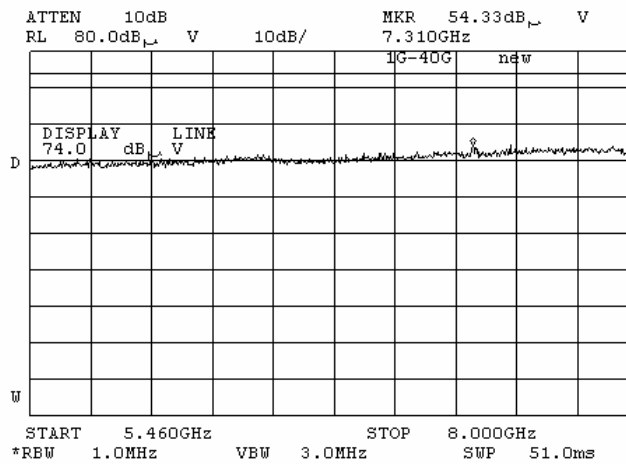

Plot 7.6.53 Radiated emission measurements from 5.46 to 8.0 GHz at the mid carrier frequency

TEST SITE: Anechoic chamber
 TEST DISTANCE: 3 m
 ANTENNA POLARIZATION: Vertical and Horizontal
 INPUTS: 802.11 b/g
 DETECTOR: Average

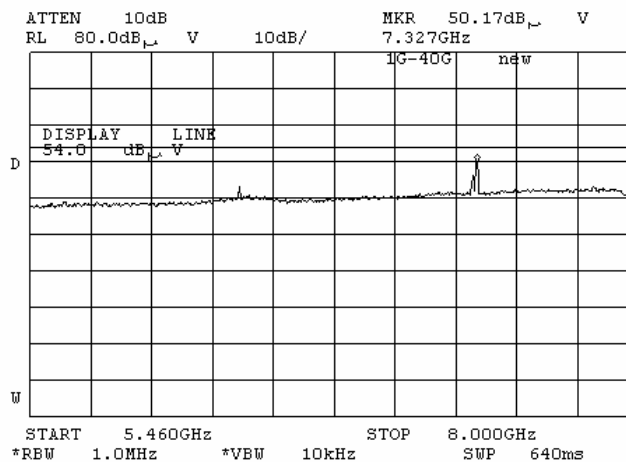

Test specification:	Section 15.247(c), Radiated spurious emissions		
Test procedure:	FR Vol. 62, page 26243, Section 15.247(c) / ANSI C63.4, Section 13.1.4		
Test mode:	Compliance	Verdict:	
Date & Time:	6/28/2006 2:24:40 PM		
Temperature: 24 °C	Air Pressure: 1014 hPa	Relative Humidity: 50 %	Power Supply: 120 VAC
Remarks: 802.11b/g			

Plot 7.6.54 Radiated emission measurements from 5.46 to 8.0 GHz at the high carrier frequency

TEST SITE: Anechoic chamber
 TEST DISTANCE: 3 m
 ANTENNA POLARIZATION: Vertical and Horizontal
 INPUTS: 802.11 b/g
 DETECTOR: Peak

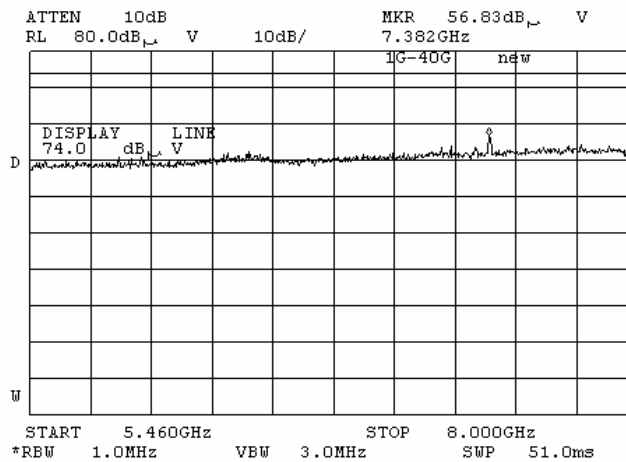

Plot 7.6.55 Radiated emission measurements from 5.46 to 8.0 GHz at the high carrier frequency

TEST SITE: Anechoic chamber
 TEST DISTANCE: 3 m
 ANTENNA POLARIZATION: Vertical and Horizontal
 INPUTS: 802.11 b/g
 DETECTOR: Average

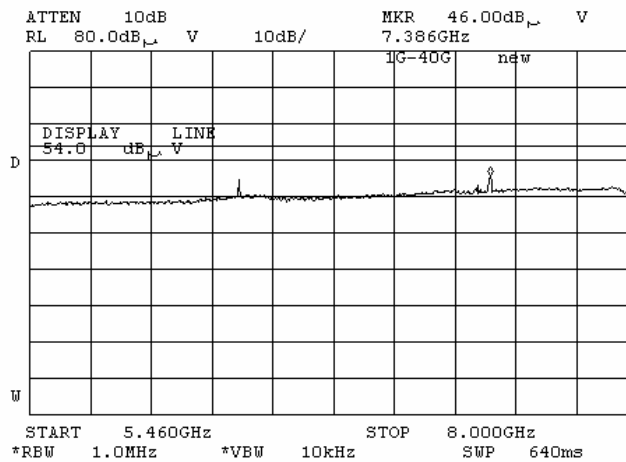

Test specification:	Section 15.247(c), Radiated spurious emissions		
Test procedure:	FR Vol. 62, page 26243, Section 15.247(c) / ANSI C63.4, Section 13.1.4		
Test mode:	Compliance	Verdict:	
Date & Time:	6/28/2006 2:24:40 PM		
Temperature: 24 °C	Air Pressure: 1014 hPa	Relative Humidity: 50 %	Power Supply: 120 VAC
Remarks: 802.11b/g			

Plot 7.6.56 Radiated emission measurements from 8.0 to 14.0 GHz at the low carrier frequency

TEST SITE: Anechoic chamber
 TEST DISTANCE: 3 m
 ANTENNA POLARIZATION: Vertical and Horizontal
 INPUTS: 802.11 b/g
 DETECTOR: Peak

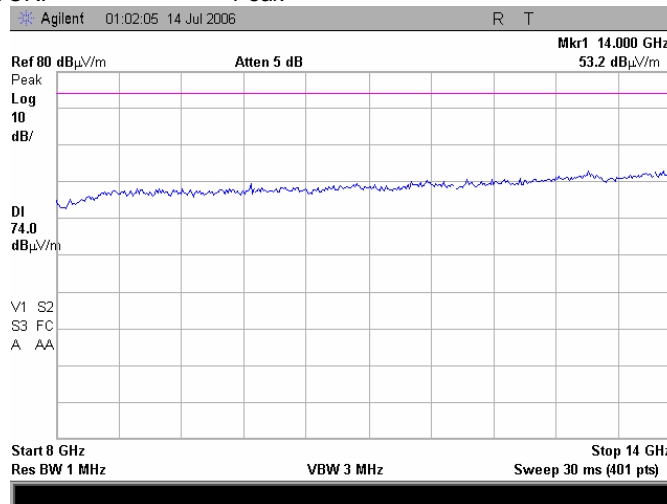

Plot 7.6.57 Radiated emission measurements from 8.0 to 14.0 GHz at the low carrier frequency

TEST SITE: Anechoic chamber
 TEST DISTANCE: 3 m
 ANTENNA POLARIZATION: Vertical and Horizontal
 INPUTS: 802.11 b/g
 DETECTOR: Average

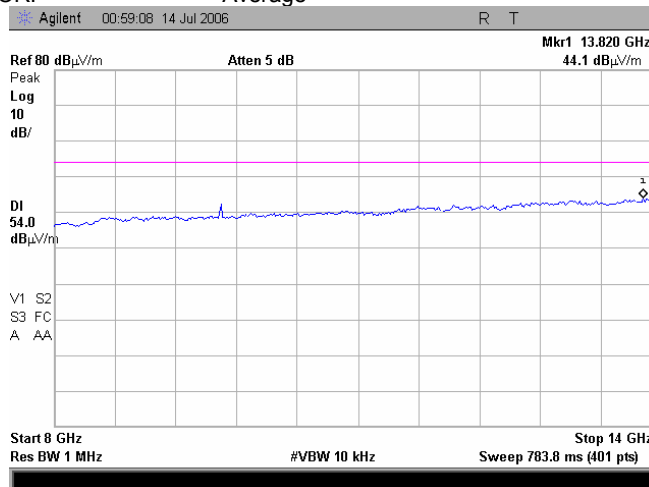

Test specification:	Section 15.247(c), Radiated spurious emissions		
Test procedure:	FR Vol. 62, page 26243, Section 15.247(c) / ANSI C63.4, Section 13.1.4		
Test mode:	Compliance	Verdict:	
Date & Time:	6/28/2006 2:24:40 PM		
Temperature: 24 °C	Air Pressure: 1014 hPa	Relative Humidity: 50 %	Power Supply: 120 VAC
Remarks: 802.11b/g			

Plot 7.6.58 Radiated emission measurements from 8.0 to 14.0 GHz at the mid carrier frequency

TEST SITE: Anechoic chamber
 TEST DISTANCE: 3 m
 ANTENNA POLARIZATION: Vertical and Horizontal
 INPUTS: 802.11 b/g
 DETECTOR: Peak

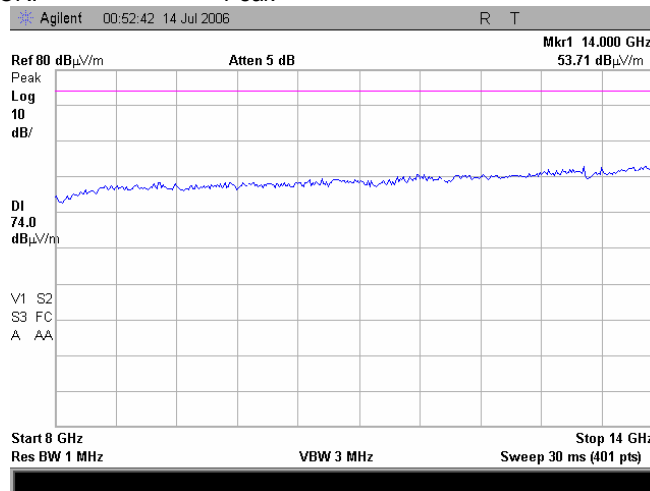

Plot 7.6.59 Radiated emission measurements from 8.0 to 14.0 GHz at the mid carrier frequency

TEST SITE: Anechoic chamber
 TEST DISTANCE: 3 m
 ANTENNA POLARIZATION: Vertical and Horizontal
 INPUTS: 802.11 b/g
 DETECTOR: Average

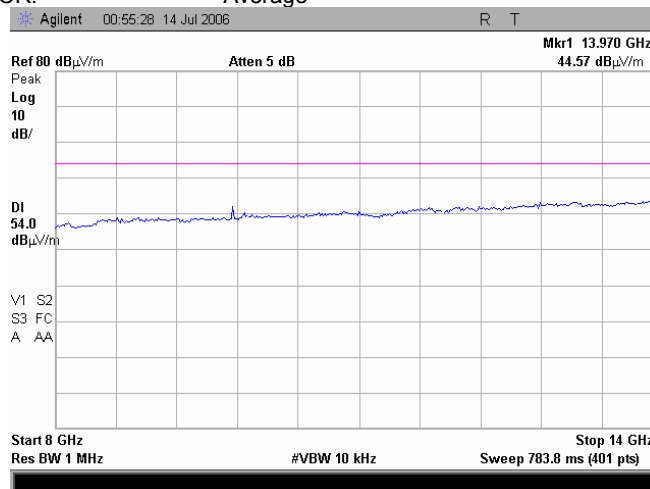

Test specification:	Section 15.247(c), Radiated spurious emissions		
Test procedure:	FR Vol. 62, page 26243, Section 15.247(c) / ANSI C63.4, Section 13.1.4		
Test mode:	Compliance	Verdict:	
Date & Time:	6/28/2006 2:24:40 PM		
Temperature: 24 °C	Air Pressure: 1014 hPa	Relative Humidity: 50 %	Power Supply: 120 VAC
Remarks: 802.11b/g			

Plot 7.6.60 Radiated emission measurements from 8.0 to 14.0 GHz at the high carrier frequency

TEST SITE: Anechoic chamber
 TEST DISTANCE: 3 m
 ANTENNA POLARIZATION: Vertical and Horizontal
 INPUTS: 802.11 b/g
 DETECTOR: Peak

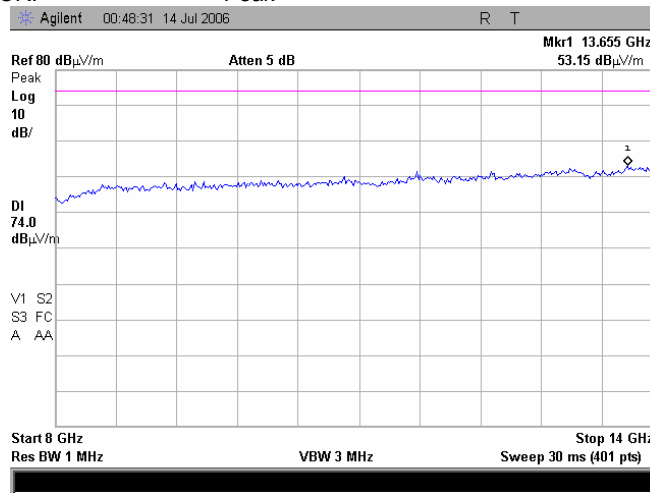

Plot 7.6.61 Radiated emission measurements from 8.0 to 14.0 GHz at the high carrier frequency

TEST SITE: Anechoic chamber
 TEST DISTANCE: 3 m
 ANTENNA POLARIZATION: Vertical and Horizontal
 INPUTS: 802.11 b/g
 DETECTOR: Average

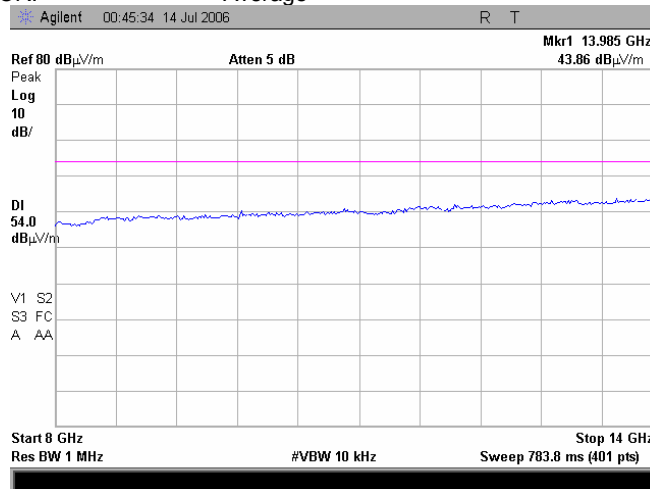

Test specification:	Section 15.247(c), Radiated spurious emissions		
Test procedure:	FR Vol. 62, page 26243, Section 15.247(c) / ANSI C63.4, Section 13.1.4		
Test mode:	Compliance	Verdict:	
Date & Time:	6/28/2006 2:24:40 PM		
Temperature: 24 °C	Air Pressure: 1014 hPa	Relative Humidity: 50 %	Power Supply: 120 VAC
Remarks: 802.11b/g			

Plot 7.6.62 Radiated emission measurements from 14.0 to 18.0 GHz at the low carrier frequency

TEST SITE: OATS
 TEST DISTANCE: 3 m
 ANTENNA POLARIZATION: Vertical and Horizontal
 INPUTS: 802.11 b/g + 802.11 a
 DETECTOR: Peak

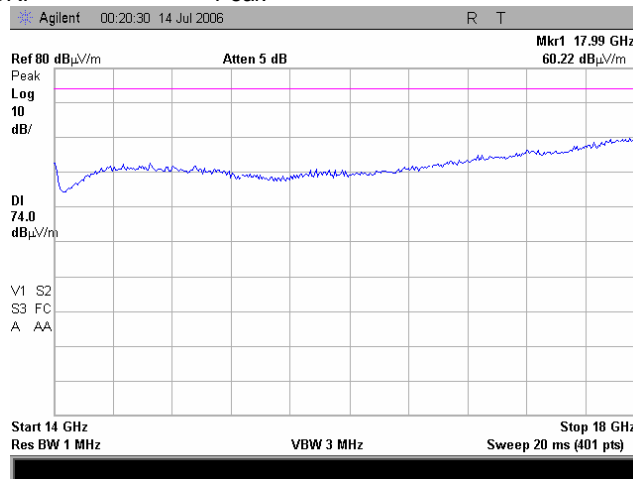

Plot 7.6.63 Radiated emission measurements from 14.0 to 18.0 GHz at the low carrier frequency

TEST SITE: OATS
 TEST DISTANCE: 3 m
 ANTENNA POLARIZATION: Vertical and Horizontal
 INPUTS: 802.11 b/g + 802.11 a
 DETECTOR: average

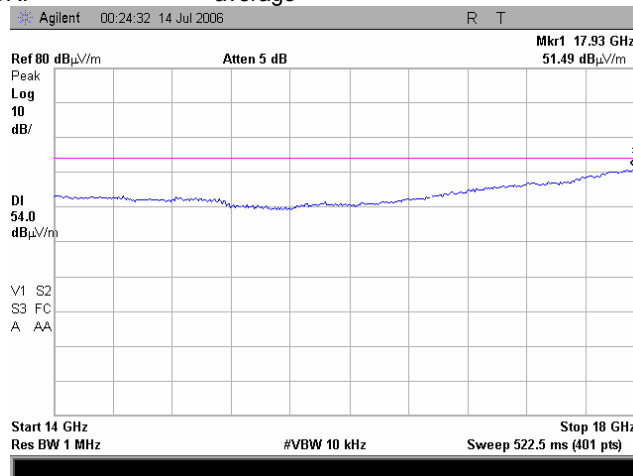

Test specification: Section 15.247(c), Radiated spurious emissions			
Test procedure: FR Vol. 62, page 26243, Section 15.247(c) / ANSI C63.4, Section 13.1.4			
Test mode: Compliance	Verdict:		
Date & Time: 6/28/2006 2:24:40 PM			
Temperature: 24 °C	Air Pressure: 1014 hPa	Relative Humidity: 50 %	Power Supply: 120 VAC
Remarks: 802.11b/g			

Plot 7.6.64 Radiated emission measurements from 14.0 to 18.0 GHz at the mid carrier frequency

TEST SITE: OATS
 TEST DISTANCE: 3 m
 ANTENNA POLARIZATION: Vertical and Horizontal
 INPUTS: 802.11 b/g
 DETECTOR: Peak

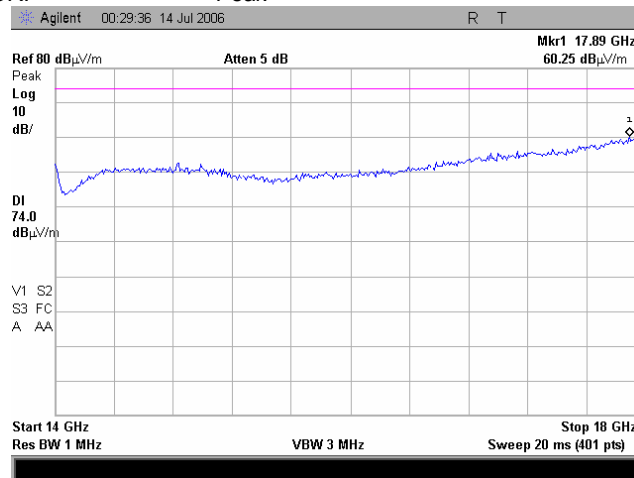

Plot 7.6.65 Radiated emission measurements from 14.0 to 18.0 GHz at the mid carrier frequency

TEST SITE: OATS
 TEST DISTANCE: 3 m
 ANTENNA POLARIZATION: Vertical and Horizontal
 INPUTS: 802.11 b/g
 DETECTOR: average

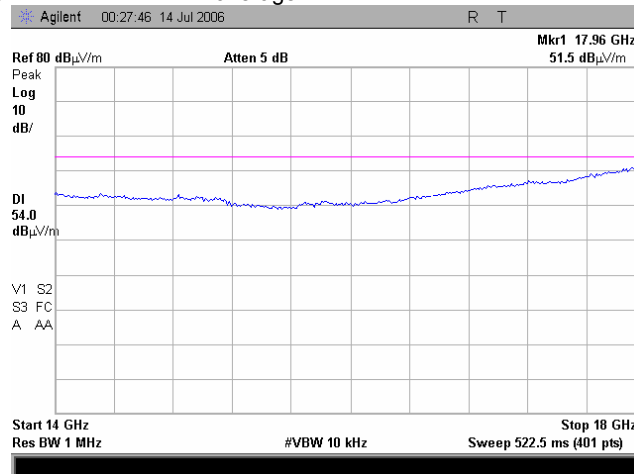

Test specification:	Section 15.247(c), Radiated spurious emissions		
Test procedure:	FR Vol. 62, page 26243, Section 15.247(c) / ANSI C63.4, Section 13.1.4		
Test mode:	Compliance	Verdict:	
Date & Time:	6/28/2006 2:24:40 PM		
Temperature: 24 °C	Air Pressure: 1014 hPa	Relative Humidity: 50 %	Power Supply: 120 VAC
Remarks: 802.11b/g			

Plot 7.6.66 Radiated emission measurements from 14.0 to 18.0 GHz at the high carrier frequency

TEST SITE: OATS
 TEST DISTANCE: 3 m
 ANTENNA POLARIZATION: Vertical and Horizontal
 INPUTS: 802.11 b/g
 DETECTOR: Peak

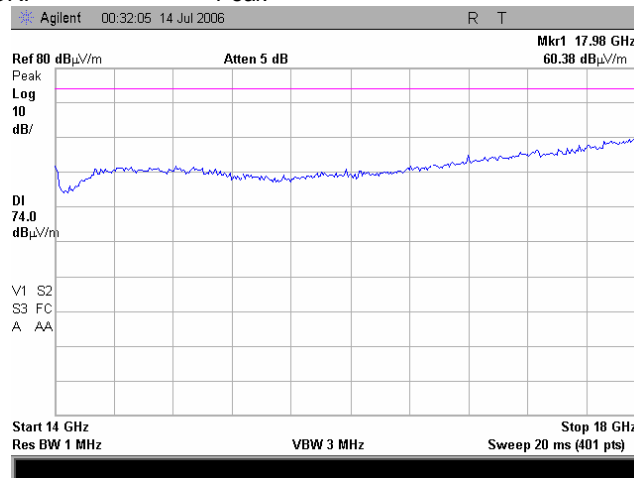

Plot 7.6.67 Radiated emission measurements from 14.0 to 18.0 GHz at the high carrier frequency

TEST SITE: OATS
 TEST DISTANCE: 3 m
 ANTENNA POLARIZATION: Vertical and Horizontal
 INPUTS: 802.11 b/g
 DETECTOR: average

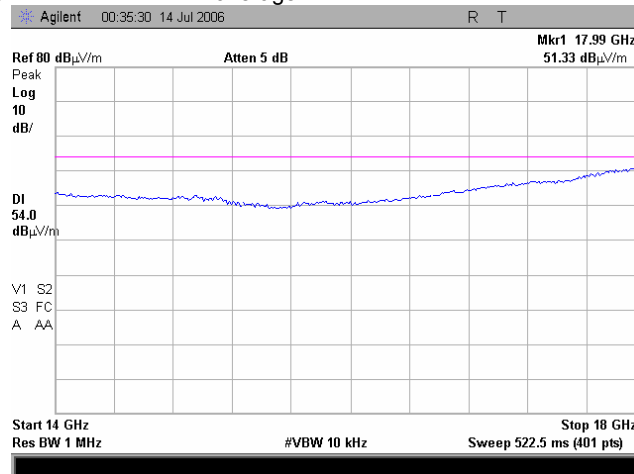

Test specification:	Section 15.247(c), Radiated spurious emissions		
Test procedure:	FR Vol. 62, page 26243, Section 15.247(c) / ANSI C63.4, Section 13.1.4		
Test mode:	Compliance	Verdict:	
Date & Time:	6/28/2006 2:24:40 PM		
Temperature: 24 °C	Air Pressure: 1014 hPa	Relative Humidity: 50 %	Power Supply: 120 VAC
Remarks: 802.11b/g			

Plot 7.6.68 Radiated emission measurements from 18.0 to 25.0 GHz at the low carrier frequency

TEST SITE: OATS
 TEST DISTANCE: 3 m
 ANTENNA POLARIZATION: Vertical and Horizontal
 INPUTS: 802.11 b/g
 DETECTOR: Peak

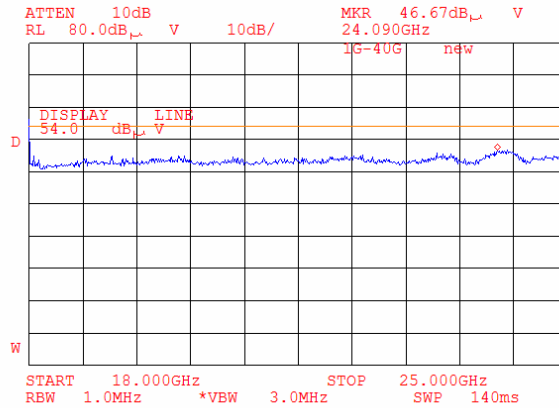

Plot 7.6.69 Radiated emission measurements from 18.0 to 25.0 GHz at the mid carrier frequency

TEST SITE: OATS
 TEST DISTANCE: 3 m
 ANTENNA POLARIZATION: Vertical and Horizontal
 INPUTS: 802.11 b/g
 DETECTOR: Peak

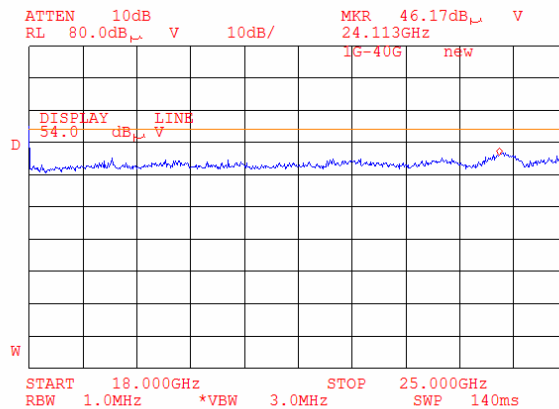

Test specification:	Section 15.247(c), Radiated spurious emissions		
Test procedure:	FR Vol. 62, page 26243, Section 15.247(c) / ANSI C63.4, Section 13.1.4		
Test mode:	Compliance	Verdict:	
Date & Time:	6/28/2006 2:24:40 PM		
Temperature: 24 °C	Air Pressure: 1014 hPa	Relative Humidity: 50 %	Power Supply: 120 VAC
Remarks: 802.11b/g			

Plot 7.6.70 Radiated emission measurements from 18.0 to 25.0 GHz at the high carrier frequency

TEST SITE: OATS
 TEST DISTANCE: 3 m
 ANTENNA POLARIZATION: Vertical and Horizontal
 INPUTS: 802.11 b/g
 DETECTOR: Peak

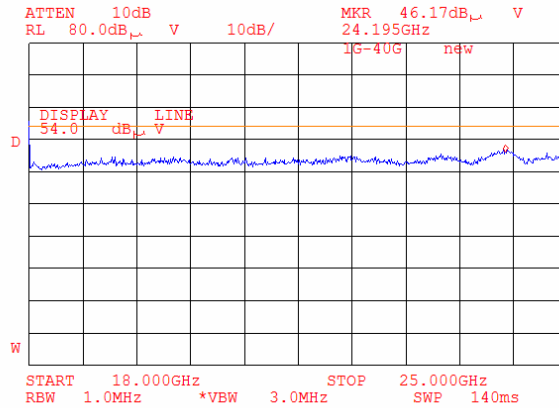

Test specification:	Section 15.247(c), Radiated spurious emissions		
Test procedure:	FR Vol. 62, page 26243, Section 15.247(c) / ANSI C63.4, Section 13.1.4		
Test mode:	Compliance	Verdict:	
Date & Time:	6/28/2006 2:24:40 PM		
Temperature: 24 °C	Air Pressure: 1014 hPa	Relative Humidity: 50 %	Power Supply: 120 VAC
Remarks: 802.11b/g			

Plot 7.6.71 Radiated emission measurements at the second harmonic of low carrier frequency

TEST SITE: OATS
TEST DISTANCE: 3 m

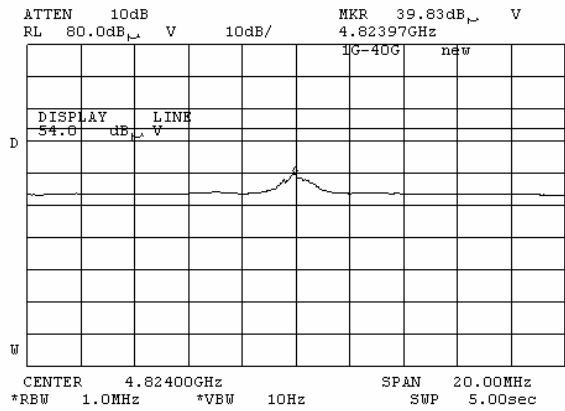
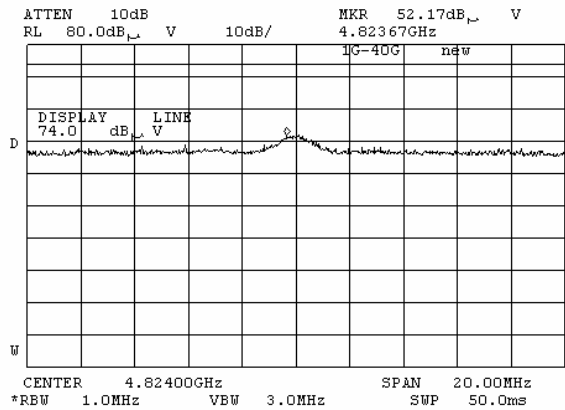

Test specification:	Section 15.247(c), Radiated spurious emissions		
Test procedure:	FR Vol. 62, page 26243, Section 15.247(c) / ANSI C63.4, Section 13.1.4		
Test mode:	Compliance	Verdict:	
Date & Time:	6/28/2006 2:24:40 PM		
Temperature: 24 °C	Air Pressure: 1014 hPa	Relative Humidity: 50 %	Power Supply: 120 VAC
Remarks: 802.11b/g			

Plot 7.6.72 Radiated emission measurements at the second harmonic of mid carrier frequency

TEST SITE: OATS
TEST DISTANCE: 3 m

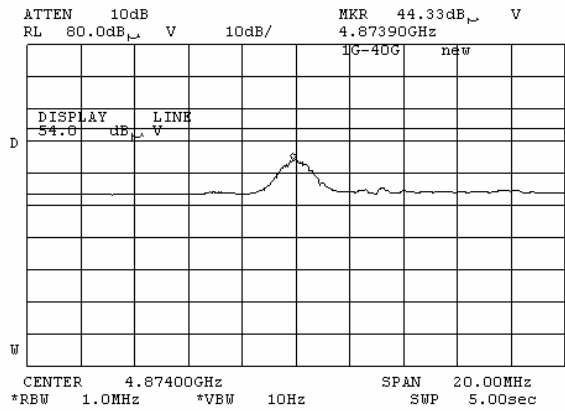
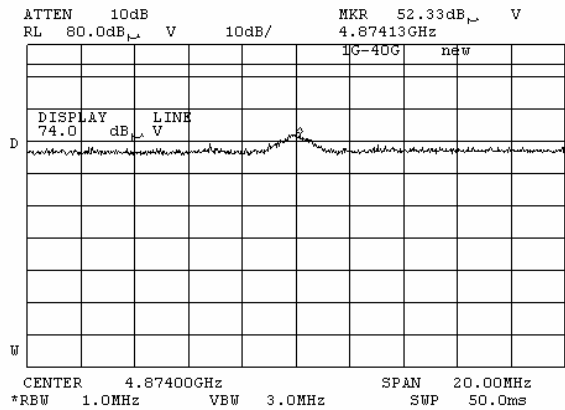

Test specification:		Section 15.247(c), Radiated spurious emissions	
Test procedure:		FR Vol. 62, page 26243, Section 15.247(c) / ANSI C63.4, Section 13.1.4	
Test mode:	Compliance	Verdict:	
Date & Time:	6/28/2006 2:24:40 PM		
Temperature: 24 °C	Air Pressure: 1014 hPa	Relative Humidity: 50 %	Power Supply: 120 VAC
Remarks: 802.11b/g			

Plot 7.6.73 Radiated emission measurements at the second harmonic of high carrier frequency

TEST SITE: OATS
TEST DISTANCE: 3 m

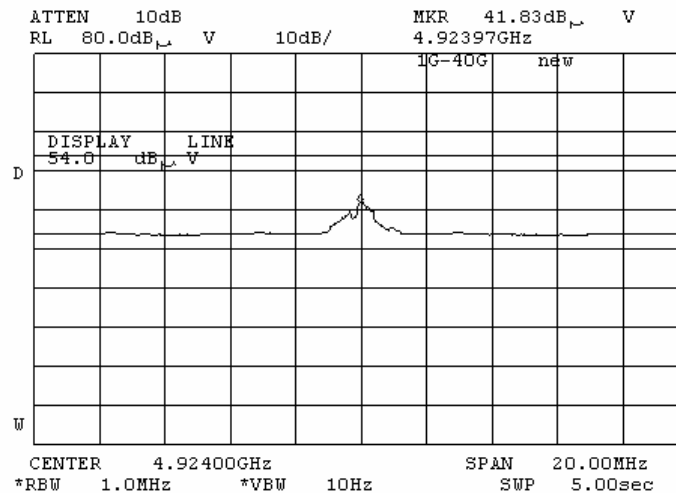
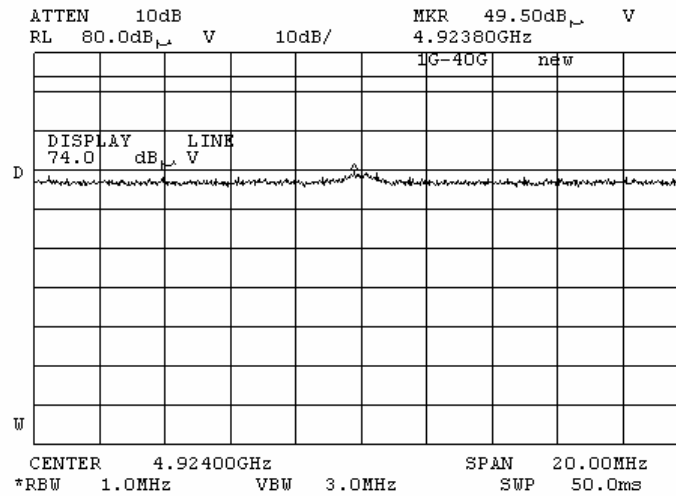

Test specification:	Section 15.247(c), Radiated spurious emissions		
Test procedure:	FR Vol. 62, page 26243, Section 15.247(c) / ANSI C63.4, Section 13.1.4		
Test mode:	Compliance	Verdict:	
Date & Time:	6/28/2006 2:24:40 PM		
Temperature: 24 °C	Air Pressure: 1014 hPa	Relative Humidity: 50 %	Power Supply: 120 VAC
Remarks: 802.11b/g			

Plot 7.674 Radiated emission measurements at the third harmonic of low carrier frequency

TEST SITE: OATS
TEST DISTANCE: 3 m

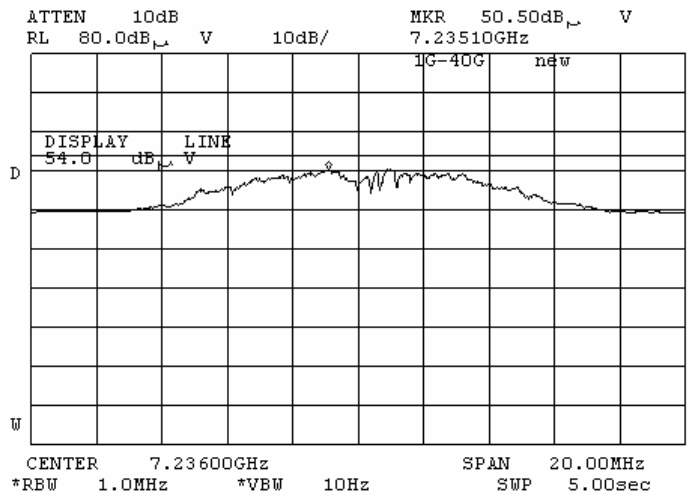
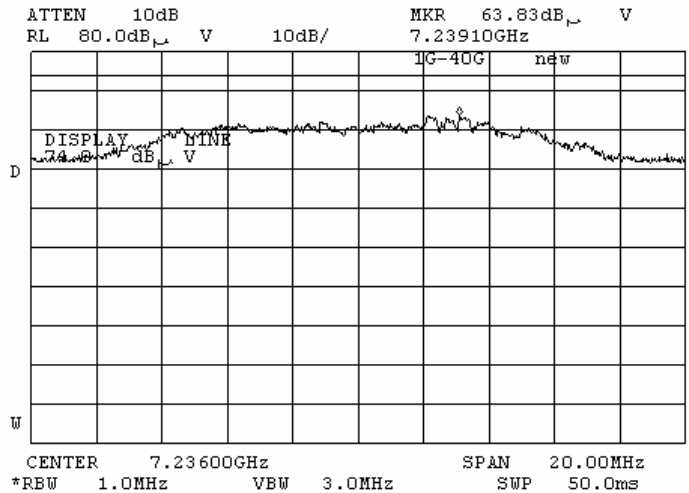

Test specification:	Section 15.247(c), Radiated spurious emissions		
Test procedure:	FR Vol. 62, page 26243, Section 15.247(c) / ANSI C63.4, Section 13.1.4		
Test mode:	Compliance	Verdict:	
Date & Time:	6/28/2006 2:24:40 PM		
Temperature: 24 °C	Air Pressure: 1014 hPa	Relative Humidity: 50 %	Power Supply: 120 VAC
Remarks: 802.11b/g			

Plot 7.6.75 Radiated emission measurements at the third harmonic of mid carrier frequency

TEST SITE: OATS
TEST DISTANCE: 3 m
DETECTOR: peak

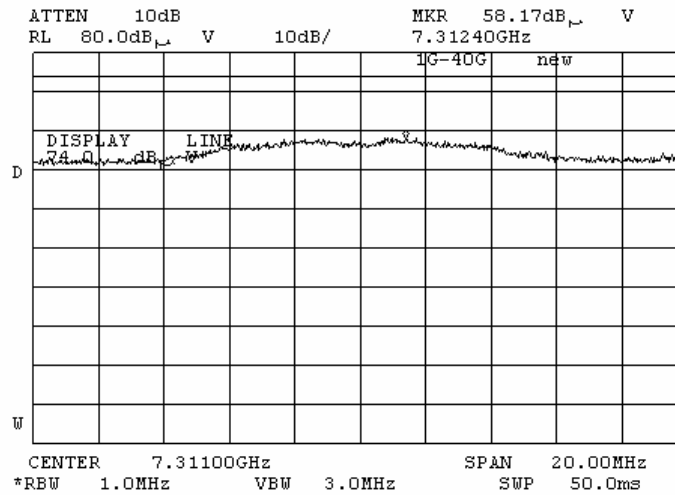

Plot 7.6.76 Radiated emission measurements at the third harmonic of mid carrier frequency

TEST SITE: OATS
TEST DISTANCE: 3 m
DETECTOR: average

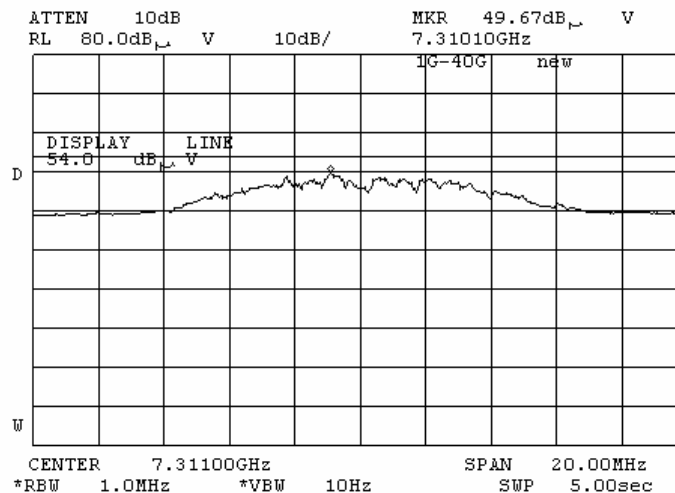

Test specification:	Section 15.247(c), Radiated spurious emissions		
Test procedure:	FR Vol. 62, page 26243, Section 15.247(c) / ANSI C63.4, Section 13.1.4		
Test mode:	Compliance	Verdict:	
Date & Time:	6/28/2006 2:24:40 PM		
Temperature: 24 °C	Air Pressure: 1014 hPa	Relative Humidity: 50 %	Power Supply: 120 VAC
Remarks: 802.11b/g			

Plot 7.6.77 Radiated emission measurements at the third harmonic of high carrier frequency

TEST SITE: OATS
TEST DISTANCE: 3 m
DETECTOR: peak

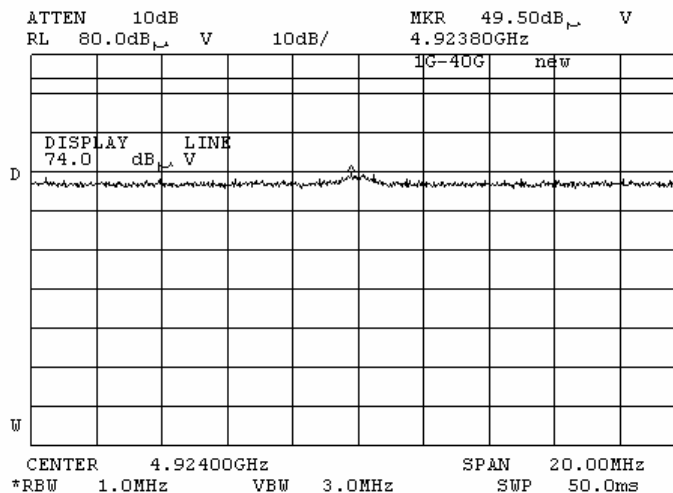

Plot 7.6.78 Radiated emission measurements at the third harmonic of high carrier frequency

TEST SITE: OATS
TEST DISTANCE: 3 m
DETECTOR: average

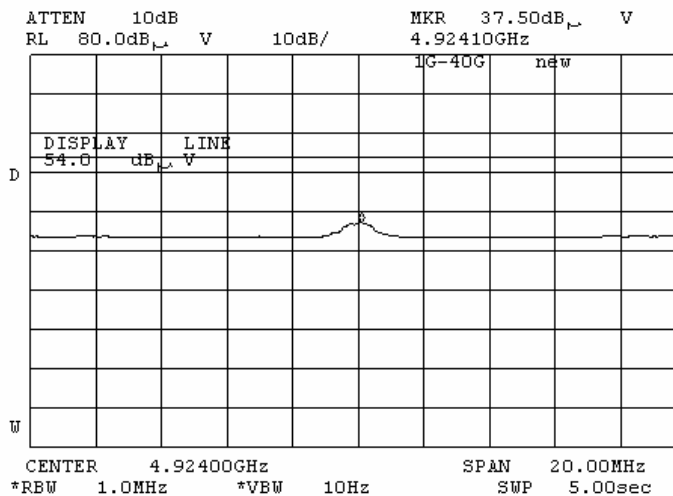

Test specification: Section 15.247(d), Peak power density			
Test procedure: FR Vol. 62, page 26243, Section 15.247(d)			
Test mode: Compliance	Verdict: PASS		
Date & Time: 6/29/2006 7:02:45 PM			
Temperature: 25.2 °C	Air Pressure: 1013 hPa	Relative Humidity: 48 %	Power Supply: AC 120V
Remarks: 802.11b/g			

7.7 Peak spectral power density

7.7.1 General

This test was performed to measure the peak spectral power density at the transmitter RF antenna connector. Specification test limits are given in Table 7.7.1.

Table 7.7.1 Peak spectral power density limits

Assigned frequency range, MHz	Measurement bandwidth, kHz	Peak spectral power density, dBm
2400.0 – 2483.5	3.0	8.0

7.7.2 Test procedure

- 7.7.2.1 The EUT was set up as shown in Figure 7.7.1, energized and its proper operation was checked.
- 7.7.2.2 The EUT was adjusted to produce maximum available to end user RF output power.
- 7.7.2.3 The frequency span of spectrum analyzer was set to capture the entire 6 dB band of the transmitter, in peak hold mode with resolution bandwidth set to 3.0 kHz, video bandwidth wider than resolution bandwidth, auto sweep time and sufficient number of sweeps was allowed for trace stabilization. The spectrum lines spacing was verified to be wider than 3 kHz. Otherwise the resolution bandwidth was reduced until individual spectrum lines were resolved and the power of individual spectrum lines was integrated over 3 kHz band.
- 7.7.2.4 The peak of emission was zoomed with span set just wide enough to capture the emission peak area and sweep time was set equal to span width divided by resolution bandwidth. Spectrum analyzer was set in peak hold mode, sufficient number of sweeps was allowed for trace stabilization and peak spectral power density was measured as provided in Table 7.7.2 and associated plots.

Figure 7.7.1 Peak spectral power density test setup

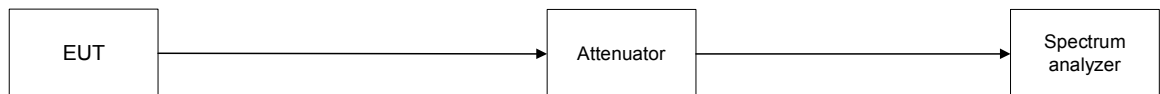

Test specification:	Section 15.247(d), Peak power density		
Test procedure:	FR Vol. 62, page 26243, Section 15.247(d)		
Test mode:	Compliance	Verdict:	PASS
Date & Time:	6/29/2006 7:02:45 PM		
Temperature: 25.2 °C	Air Pressure: 1013 hPa	Relative Humidity: 48 %	Power Supply: AC 120V
Remarks: 802.11b/g			

Table 7.7.2 Peak spectral power density test results

ASSIGNED FREQUENCY: 2400.0 – 2483.5 MHz
 MODULATION: DBPSK, CCK, BPSK, 64-QAM
 MODULATING SIGNAL: PRBS
 BIT RATE: 1, 11, 6, 54 Mbps
 TRANSMITTER OUTPUT POWER SETTINGS: Maximum
 DETECTOR USED: Peak
 RESOLUTION BANDWIDTH: 3 kHz
 VIDEO BANDWIDTH: 10 kHz
 INPUTS: 802.11 b/g

Carrier frequency, MHz	Spectrum analyzer reading, dBm/Hz	External attenuation, dB	Cable loss, dB	Peak power density, dB(mW/3 kHz)**	Limit, dBm	Margin*, dB	Verdict
DSSS, 1 Mbps							
2412	-41.02	Included	Included	-6.02	8.0	-14.02	Pass
2437	-39.64	Included	Included	-4.64	8.0	-12.64	Pass
2462	-41.58	Included	Included	-6.58	8.0	-14.58	Pass
DSSS, 11 Mbps							
2412	-41.71	Included	Included	-6.71	8.0	-14.71	Pass
2437	-41.05	Included	Included	-6.05	8.0	-14.05	Pass
2462	-42.40	Included	Included	-6.40	8.0	-14.40	Pass
OFDM, 6 Mbps							
2412	-10.85	Included	Included	-10.85	8.0	-18.85	Pass
2437	-10.08	Included	Included	-10.08	8.0	-18.08	Pass
2462	-11.46	Included	Included	-11.46	8.0	-19.46	Pass
OFDM, 54 Mbps							
2412	-10.57	Included	Included	-10.57	8.0	-18.57	Pass
2437	-9.28	Included	Included	-9.28	8.0	-17.28	Pass
2462	-9.91	Included	Included	-9.91	8.0	-17.91	Pass

* - Margin = Peak power density – specification limit.

** - DSSS measurements: Peak power density = Spectrum analyzer reading + BW factor = Spectrum analyzer reading + 10log(3kHz / 1 Hz) = Spectrum analyzer reading + 35 dB

Reference numbers of test equipment used

HL 1650	HL 2524	HL 2867	HL 2909				
---------	---------	---------	---------	--	--	--	--

Full description is given in Appendix A.

Test specification:	Section 15.247(d), Peak power density		
Test procedure:	FR Vol. 62, page 26243, Section 15.247(d)		
Test mode:	Compliance	Verdict:	PASS
Date & Time:	6/29/2006 7:02:45 PM		
Temperature: 25.2 °C	Air Pressure: 1013 hPa	Relative Humidity: 48 %	Power Supply: AC 120V
Remarks: 802.11b/g			

Plot 7.7.1 Peak spectral power density at low frequency within 6 dB band at 1 Mbps DSSS

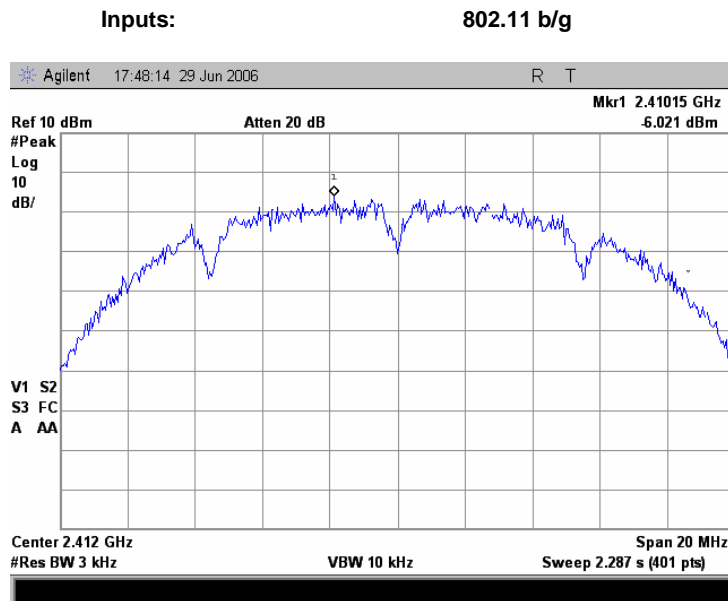

Plot 7.7.2 Peak spectral power density at low frequency zoomed at the peak at 1 Mbps DSSS

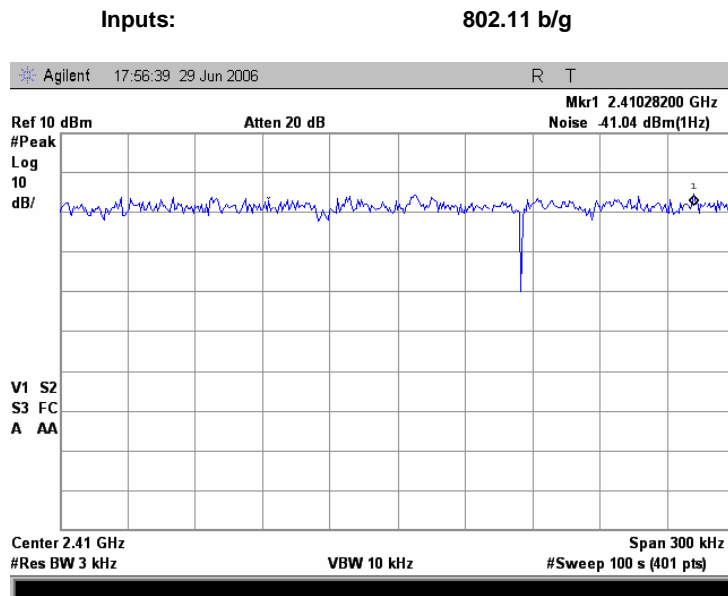

Test specification:	Section 15.247(d), Peak power density		
Test procedure:	FR Vol. 62, page 26243, Section 15.247(d)		
Test mode:	Compliance	Verdict:	PASS
Date & Time:	6/29/2006 7:02:45 PM		
Temperature: 25.2 °C	Air Pressure: 1013 hPa	Relative Humidity: 48 %	Power Supply: AC 120V
Remarks: 802.11b/g			

Plot 7.7.3 Peak spectral power density at mid frequency within 6 dB band at 1 Mbps DSSS

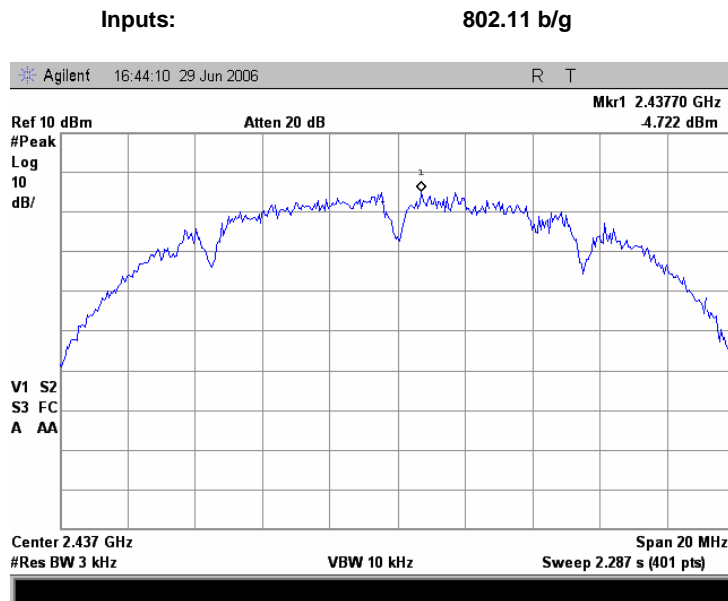

Plot 7.7.4 Peak spectral power density at mid frequency zoomed at the peak at 1 Mbps DSSS

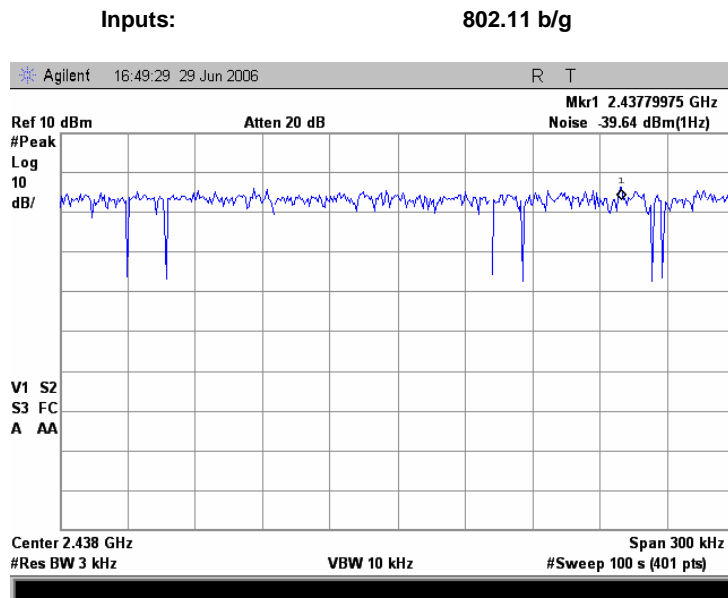

Test specification:	Section 15.247(d), Peak power density		
Test procedure:	FR Vol. 62, page 26243, Section 15.247(d)		
Test mode:	Compliance	Verdict: PASS	
Date & Time:	6/29/2006 7:02:45 PM		
Temperature: 25.2 °C	Air Pressure: 1013 hPa	Relative Humidity: 48 %	Power Supply: AC 120V
Remarks: 802.11b/g			

Plot 7.7.5 Peak spectral power density at high frequency within 6 dB band at 1 Mbps DSSS

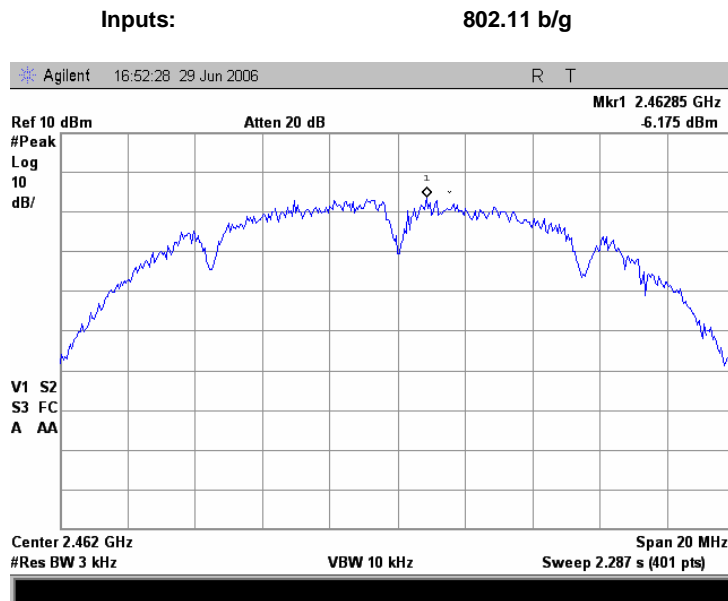

Plot 7.7.6 Peak spectral power density at high frequency zoomed at the peak at 1 Mbps DSSS

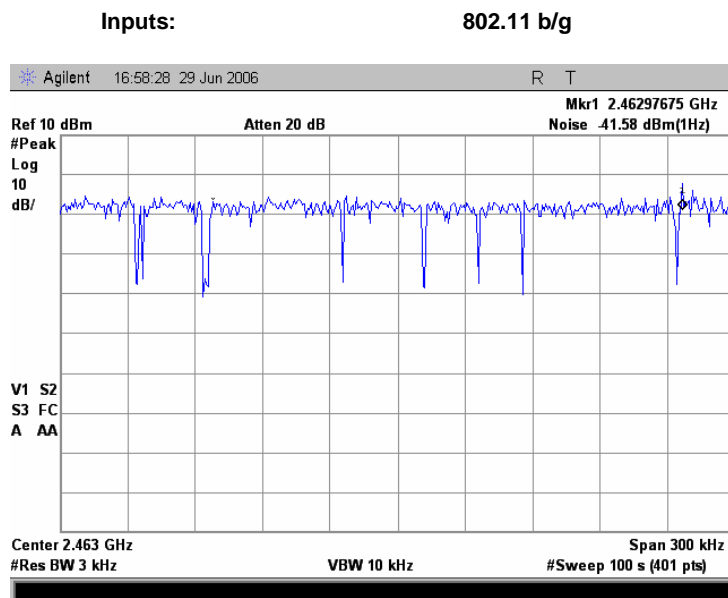

Test specification:	Section 15.247(d), Peak power density		
Test procedure:	FR Vol. 62, page 26243, Section 15.247(d)		
Test mode:	Compliance	Verdict:	PASS
Date & Time:	6/29/2006 7:02:45 PM		
Temperature: 25.2 °C	Air Pressure: 1013 hPa	Relative Humidity: 48 %	Power Supply: AC 120V
Remarks: 802.11b/g			

Plot 7.7.7 Peak spectral power density at low frequency within 6 dB band at 11 Mbps DSSS

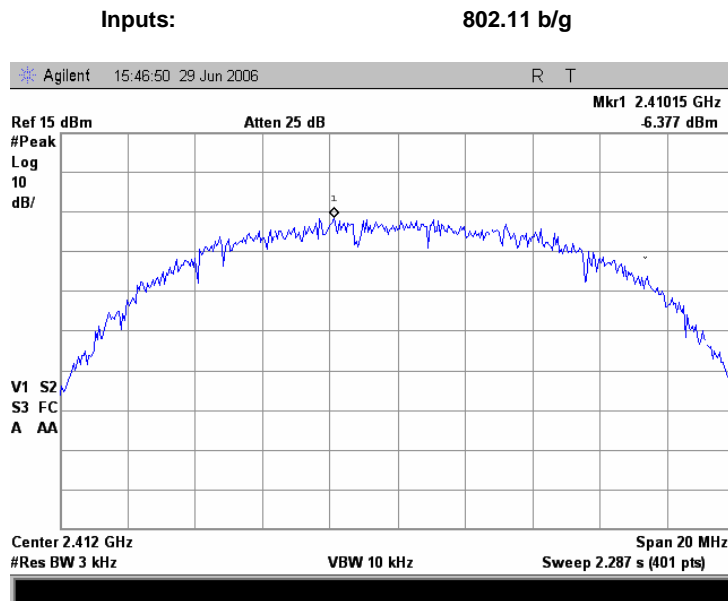

Plot 7.7.8 Peak spectral power density at low frequency zoomed at the peak at 11 Mbps DSSS

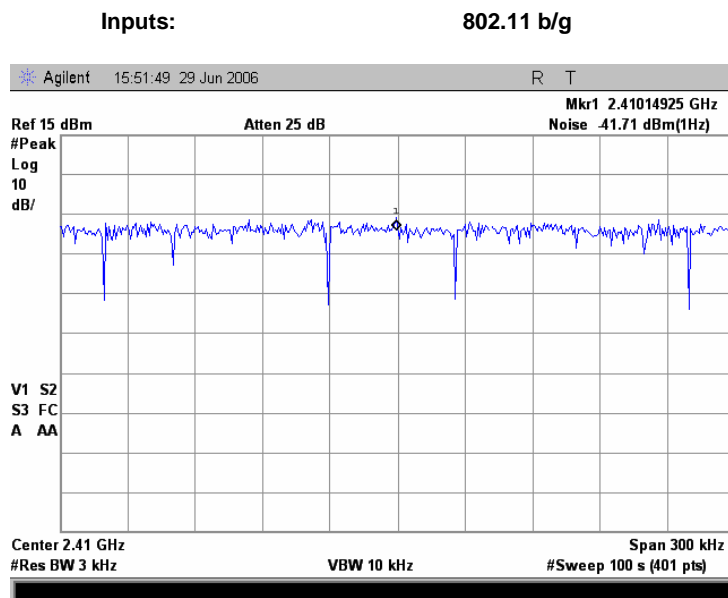

Test specification:	Section 15.247(d), Peak power density		
Test procedure:	FR Vol. 62, page 26243, Section 15.247(d)		
Test mode:	Compliance	Verdict:	PASS
Date & Time:	6/29/2006 7:02:45 PM		
Temperature: 25.2 °C	Air Pressure: 1013 hPa	Relative Humidity: 48 %	Power Supply: AC 120V
Remarks: 802.11b/g			

Plot 7.7.9 Peak spectral power density at mid frequency within 6 dB band at 11 Mbps DSSS

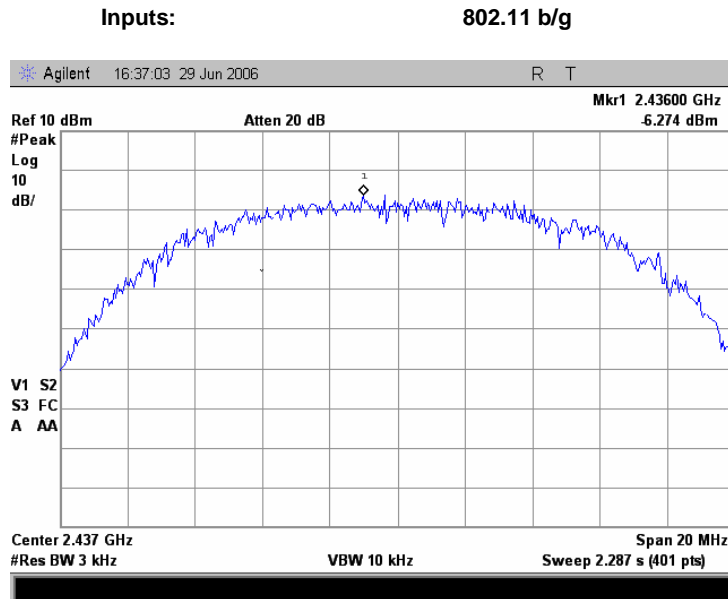

Plot 7.7.10 Peak spectral power density at mid frequency zoomed at the peak at 11 Mbps DSSS

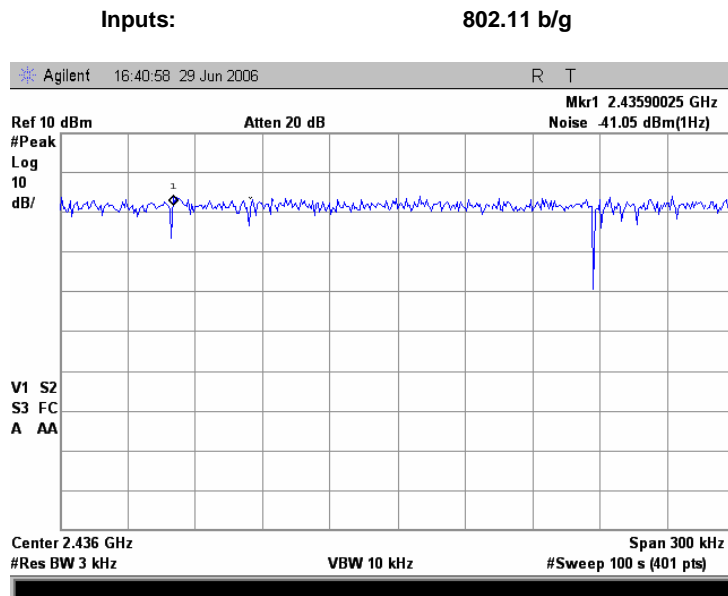

Test specification:	Section 15.247(d), Peak power density		
Test procedure:	FR Vol. 62, page 26243, Section 15.247(d)		
Test mode:	Compliance	Verdict:	PASS
Date & Time:	6/29/2006 7:02:45 PM		
Temperature: 25.2 °C	Air Pressure: 1013 hPa	Relative Humidity: 48 %	Power Supply: AC 120V
Remarks: 802.11b/g			

Plot 7.7.11 Peak spectral power density at high frequency within 6 dB band at 11 Mbps DSSS

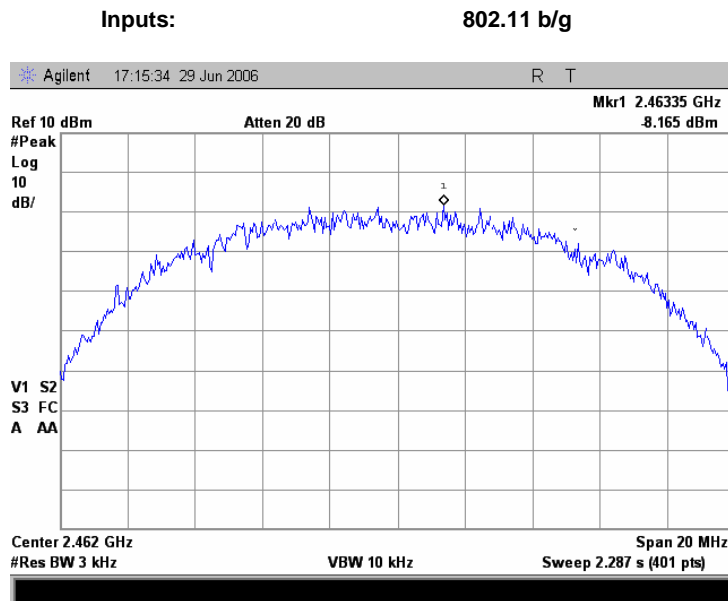

Plot 7.7.12 Peak spectral power density at high frequency zoomed at the peak at 11 Mbps DSSS

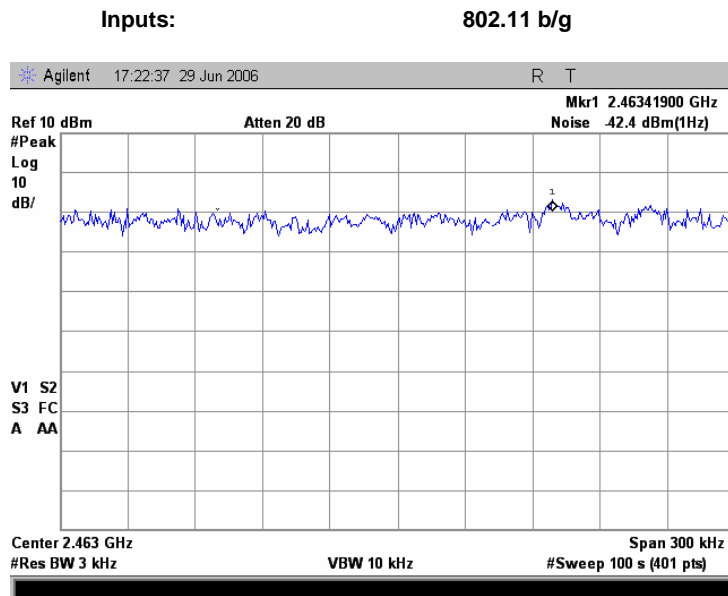

Test specification:	Section 15.247(d), Peak power density		
Test procedure:	FR Vol. 62, page 26243, Section 15.247(d)		
Test mode:	Compliance	Verdict:	PASS
Date & Time:	6/29/2006 7:02:45 PM		
Temperature: 25.2 °C	Air Pressure: 1013 hPa	Relative Humidity: 48 %	Power Supply: AC 120V
Remarks: 802.11b/g			

Plot 7.7.13 Peak spectral power density at low frequency within 6 dB band at 6 Mbps OFDM

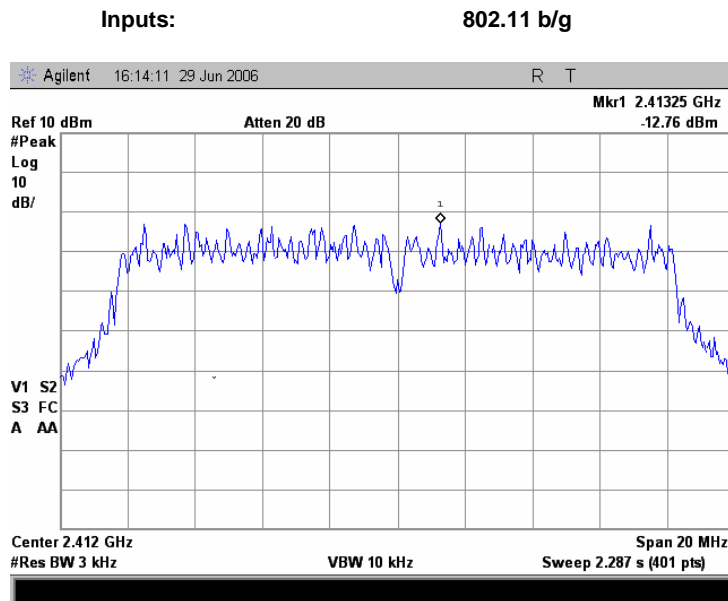

Plot 7.7.14 Peak spectral power density at low frequency zoomed at the peak at 6 Mbps OFDM

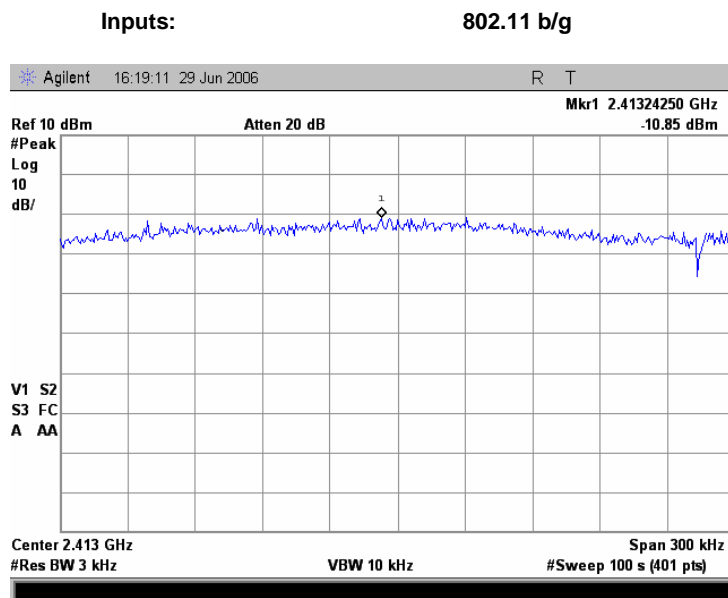

Test specification:	Section 15.247(d), Peak power density		
Test procedure:	FR Vol. 62, page 26243, Section 15.247(d)		
Test mode:	Compliance	Verdict:	PASS
Date & Time:	6/29/2006 7:02:45 PM		
Temperature: 25.2 °C	Air Pressure: 1013 hPa	Relative Humidity: 48 %	Power Supply: AC 120V
Remarks: 802.11b/g			

Plot 7.7.15 Peak spectral power density at mid frequency within 6 dB band at 6 Mbps OFDM

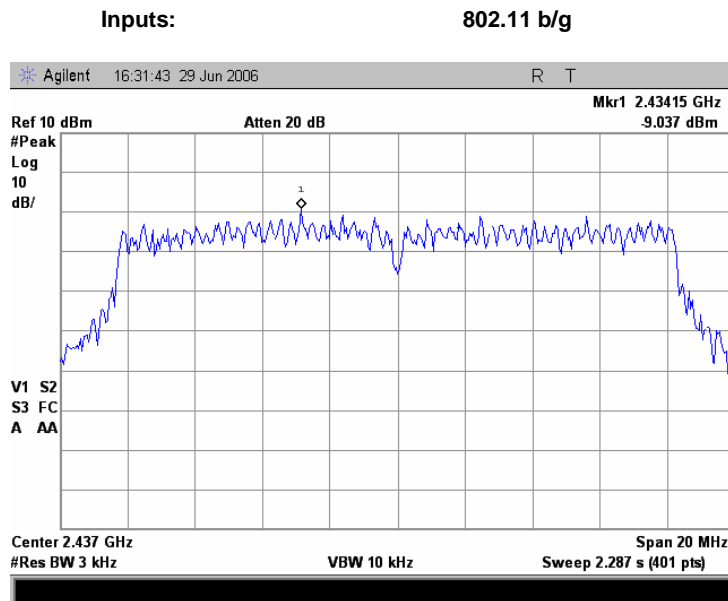

Plot 7.7.16 Peak spectral power density at mid frequency zoomed at the peak at 6 Mbps OFDM

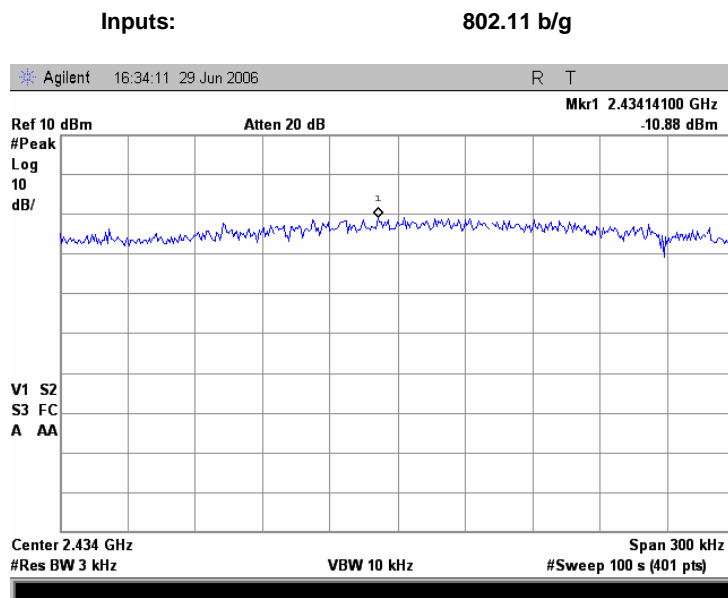

Test specification:	Section 15.247(d), Peak power density		
Test procedure:	FR Vol. 62, page 26243, Section 15.247(d)		
Test mode:	Compliance	Verdict:	PASS
Date & Time:	6/29/2006 7:02:45 PM		
Temperature: 25.2 °C	Air Pressure: 1013 hPa	Relative Humidity: 48 %	Power Supply: AC 120V
Remarks: 802.11b/g			

Plot 7.7.17 Peak spectral power density at high frequency within 6 dB band at 6 Mbps OFDM

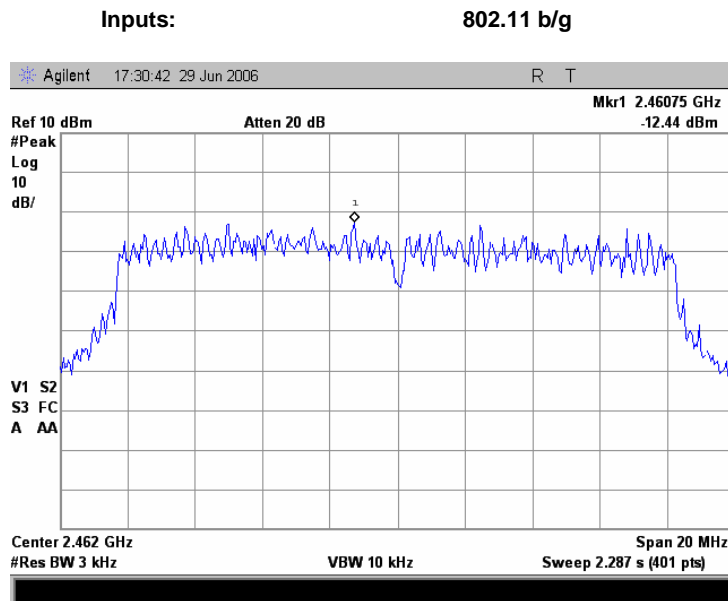

Plot 7.7.18 Peak spectral power density at high frequency zoomed at the peak at 6 Mbps OFDM

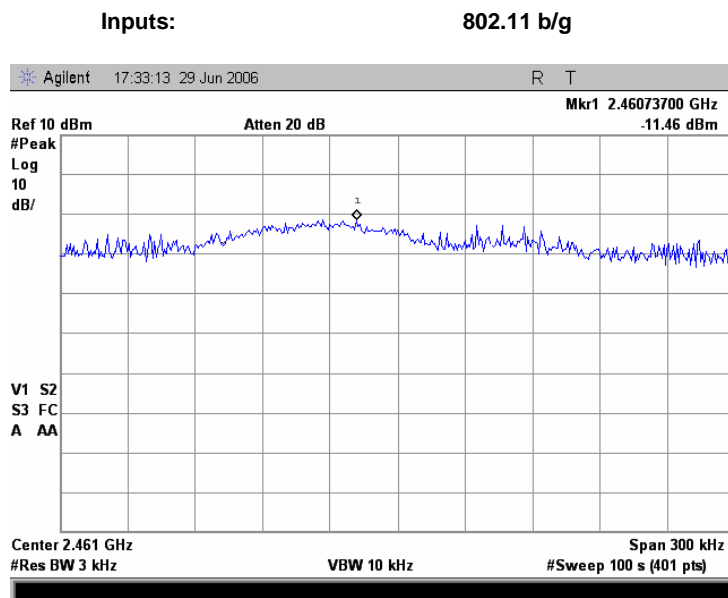

Test specification:	Section 15.247(d), Peak power density		
Test procedure:	FR Vol. 62, page 26243, Section 15.247(d)		
Test mode:	Compliance	Verdict:	PASS
Date & Time:	6/29/2006 7:02:45 PM		
Temperature: 25.2 °C	Air Pressure: 1013 hPa	Relative Humidity: 48 %	Power Supply: AC 120V
Remarks: 802.11b/g			

Plot 7.7.19 Peak spectral power density at low frequency within 6 dB band at 54 Mbps OFDM

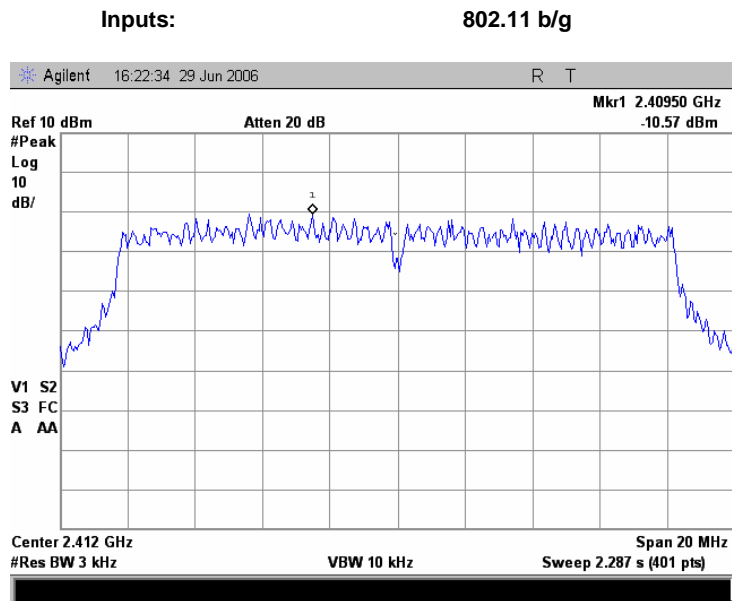

Plot 7.7.20 Peak spectral power density at low frequency zoomed at the peak at 54 Mbps OFDM

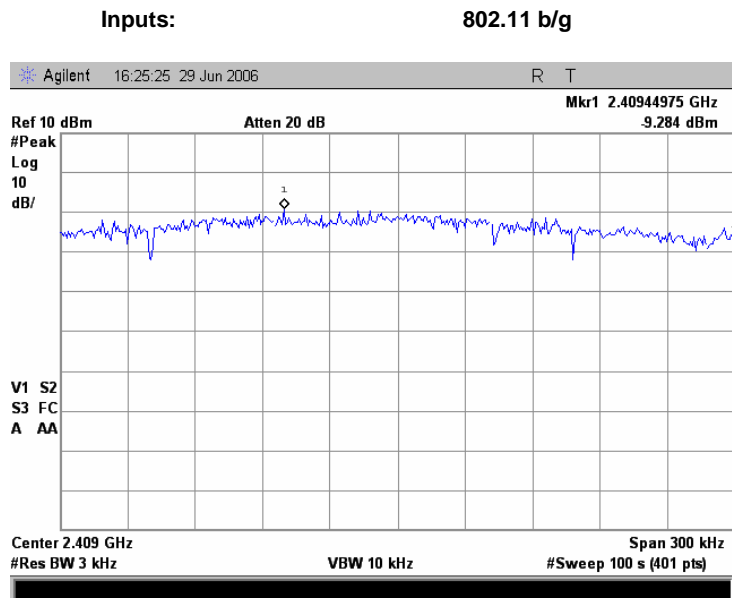

Test specification:	Section 15.247(d), Peak power density		
Test procedure:	FR Vol. 62, page 26243, Section 15.247(d)		
Test mode:	Compliance	Verdict:	PASS
Date & Time:	6/29/2006 7:02:45 PM		
Temperature: 25.2 °C	Air Pressure: 1013 hPa	Relative Humidity: 48 %	Power Supply: AC 120V
Remarks: 802.11b/g			

Plot 7.7.21 Peak spectral power density at mid frequency within 6 dB band at 54 Mbps OFDM

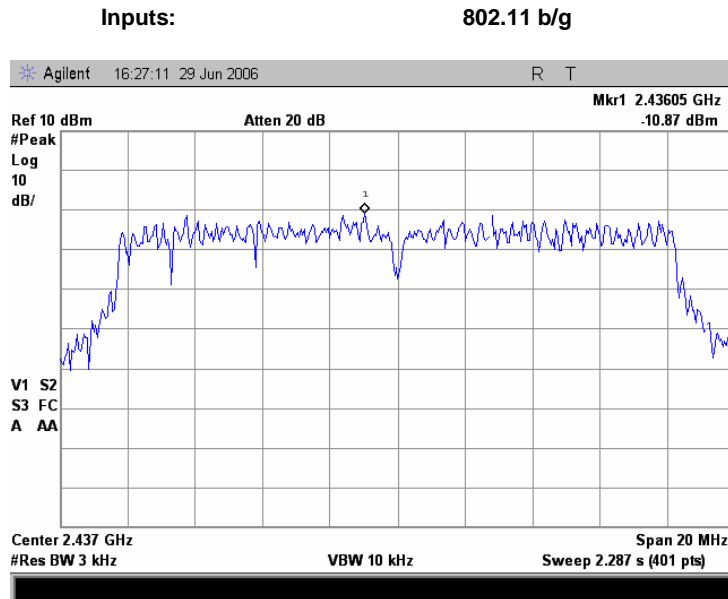

Plot 7.7.22 Peak spectral power density at mid frequency zoomed at the peak at 54 Mbps OFDM

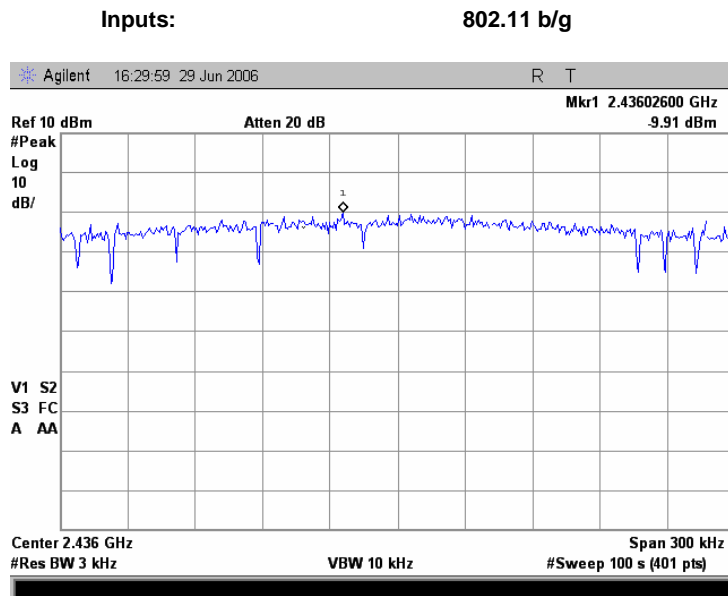

Test specification:	Section 15.247(d), Peak power density		
Test procedure:	FR Vol. 62, page 26243, Section 15.247(d)		
Test mode:	Compliance	Verdict:	PASS
Date & Time:	6/29/2006 7:02:45 PM		
Temperature: 25.2 °C	Air Pressure: 1013 hPa	Relative Humidity: 48 %	Power Supply: AC 120V
Remarks: 802.11b/g			

Plot 7.7.23 Peak spectral power density at high frequency within 6 dB band at 54 Mbps OFDM

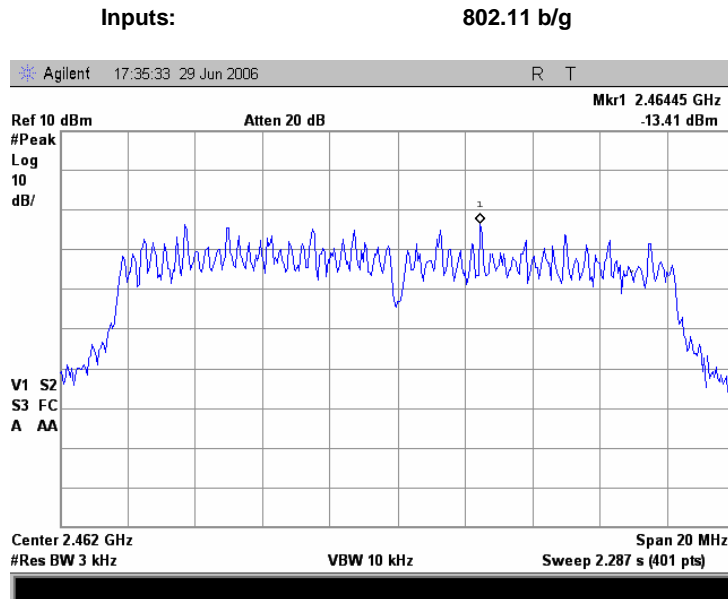

Plot 7.7.24 Peak spectral power density at high frequency zoomed at the peak at 54 Mbps OFDM

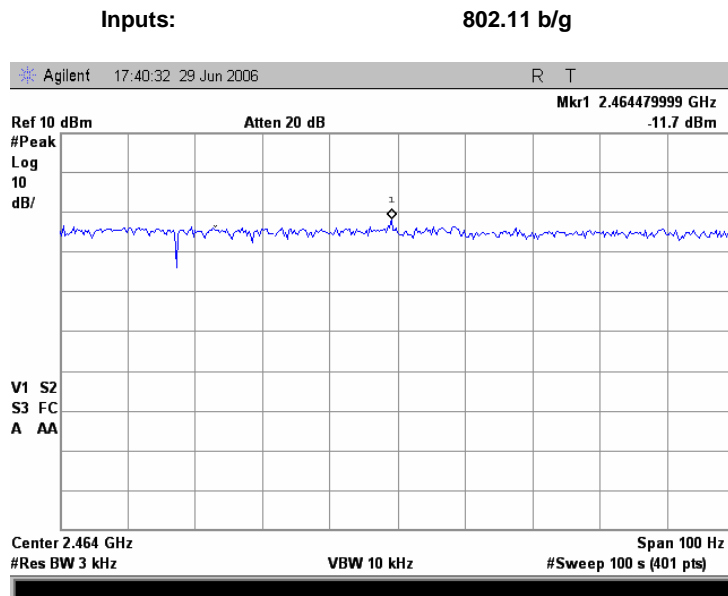

Test specification:	Section 15.247(d), Peak power density		
Test procedure:	FR Vol. 62, page 26243, Section 15.247(d)		
Test mode:	Compliance	Verdict:	PASS
Date & Time:	7/2/2006 6:20:52 PM		
Temperature: 24 °C	Air Pressure: 1015 hPa	Relative Humidity: 40 %	Power Supply: 120 VAC
Remarks:			

Table 7.7.3 Peak spectral power density test results

ASSIGNED FREQUENCY: 2400.0 – 2483.5 MHz
 MODULATION: DBPSK, CCK, BPSK, 64QAM
 MODULATING SIGNAL: PRBS
 BIT RATE: 1, 11, 6, 54 Mbps
 TRANSMITTER OUTPUT POWER SETTINGS: Maximum
 DETECTOR USED: Peak
 INPUTS: 802.11 b/g + 802.11 a

Carrier frequency, MHz	Spectrum analyzer reading, dBm/Hz	External attenuation, dB	Cable loss, dB	Peak power density, dB(mW/3 kHz)**	Limit, dBm	Margin*, dB	Verdict
DSSS, 1 Mbps							
2412	-36.56	Included	Included	-1.56	8.0	-9.56	Pass
2437	-34.98	Included	Included	0.02	8.0	-7.98	Pass
2462	-36.48	Included	Included	-1.48	8.0	-9.48	Pass
DSSS, 11 Mbps							
2412	-37.49	Included	Included	-2.49	8.0	-10.49	Pass
2437	-37.09	Included	Included	-2.09	8.0	-10.09	Pass
2462	-36.29	Included	Included	-1.29	8.0	-9.29	Pass
OFDM, 6 Mbps							
2412	-4.07	Included	Included	-4.07	8.0	-12.07	Pass
2437	-2.34	Included	Included	-2.34	8.0	-10.34	Pass
2462	-3.37	Included	Included	-3.37	8.0	-11.37	Pass
OFDM, 54 Mbps							
2412	-6.56	Included	Included	-6.56	8.0	-14.56	Pass
2437	-6.67	Included	Included	-6.67	8.0	-14.67	Pass
2462	-5.53	Included	Included	-5.53	8.0	-13.53	Pass

INPUTS: 802.11 b/g + 802.11 a + licensed

Carrier frequency, MHz	Spectrum analyzer reading, dBm/Hz	External attenuation, dB	Cable loss, dB	Peak power density, dB(mW/3 kHz)**	Limit, dBm	Margin*, dB	Verdict
DSSS, 1 Mbps							
2412	-35.95	Included	Included	-0.95	8.0	-8.95	Pass
2437	-36.62	Included	Included	-1.62	8.0	-9.62	Pass
2462	-36.98	Included	Included	-1.98	8.0	-9.98	Pass
DSSS, 11 Mbps							
2412	-36.77	Included	Included	-1.77	8.0	-9.77	Pass
2437	-36.14	Included	Included	-1.14	8.0	-9.14	Pass
2462	-37.38	Included	Included	-2.38	8.0	-10.38	Pass
OFDM, 6 Mbps							
2412	-4.59	Included	Included	-4.59	8.0	-12.59	Pass
2437	-3.28	Included	Included	-3.28	8.0	-11.28	Pass
2462	-4.68	Included	Included	-4.68	8.0	-12.68	Pass
OFDM, 54 Mbps							
2412	-6.51	Included	Included	-6.51	8.0	-14.51	Pass
2437	-6.52	Included	Included	-6.52	8.0	-14.52	Pass
2462	-6.32	Included	Included	-6.32	8.0	-14.32	Pass

* - Margin = Peak power density – specification limit.

** - DSSS measurements: Peak power density = Spectrum analyzer reading + BW factor = Spectrum analyzer reading + 10log(3kHz / 1 Hz) = Spectrum analyzer reading + 35 dB

Reference numbers of test equipment used

HL 1650	HL 2780	HL 2867					
---------	---------	---------	--	--	--	--	--

Full description is given in Appendix A.

Test specification:	Section 15.247(d), Peak power density		
Test procedure:	FR Vol. 62, page 26243, Section 15.247(d)		
Test mode:	Compliance	Verdict:	PASS
Date & Time:	7/2/2006 6:20:52 PM		
Temperature: 24 °C	Air Pressure: 1015 hPa	Relative Humidity: 40 %	Power Supply: 120 VAC
Remarks:			

Plot 7.7.25 Peak spectral power density at low frequency within 6 dB band at 1 Mbps DSSS

Inputs: 802.11 b/g + 802.11 a

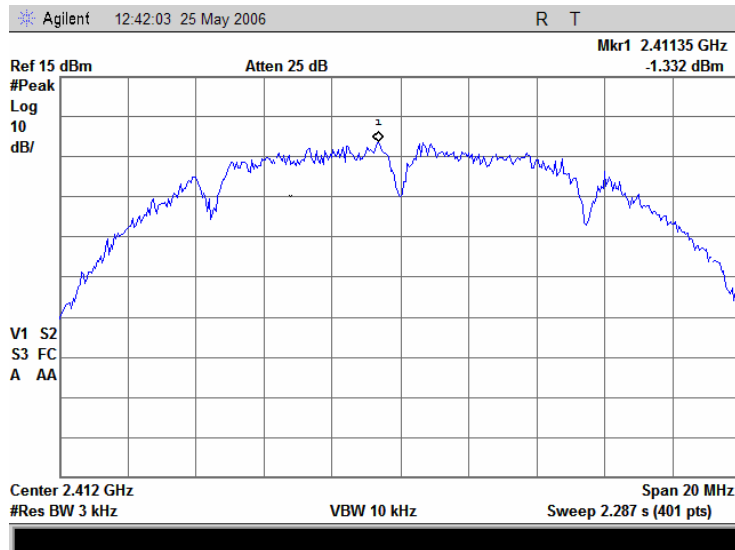

Plot 7.7.26 Peak spectral power density at low frequency zoomed at the peak at 1 Mbps DSSS

Inputs: 802.11 b/g + 802.11 a

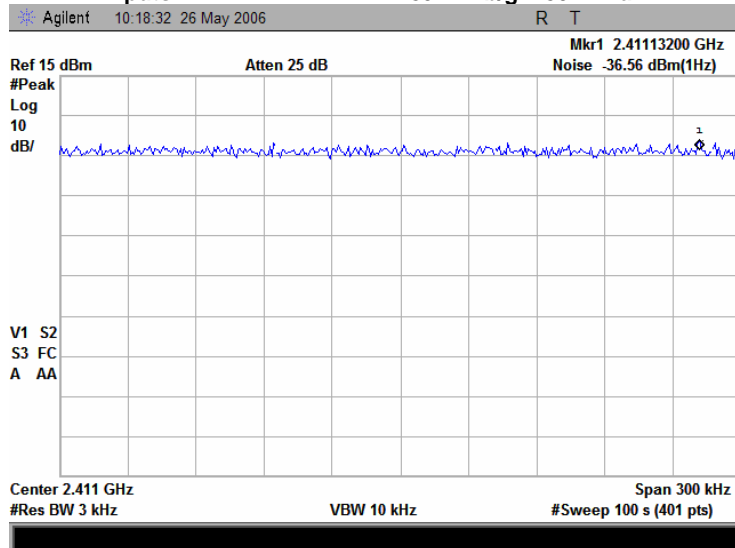

Test specification:	Section 15.247(d), Peak power density		
Test procedure:	FR Vol. 62, page 26243, Section 15.247(d)		
Test mode:	Compliance	Verdict:	PASS
Date & Time:	7/2/2006 6:20:52 PM		
Temperature: 24 °C	Air Pressure: 1015 hPa	Relative Humidity: 40 %	Power Supply: 120 VAC
Remarks:			

Plot 7.7.27 Peak spectral power density at mid frequency within 6 dB band at 1 Mbps DSSS

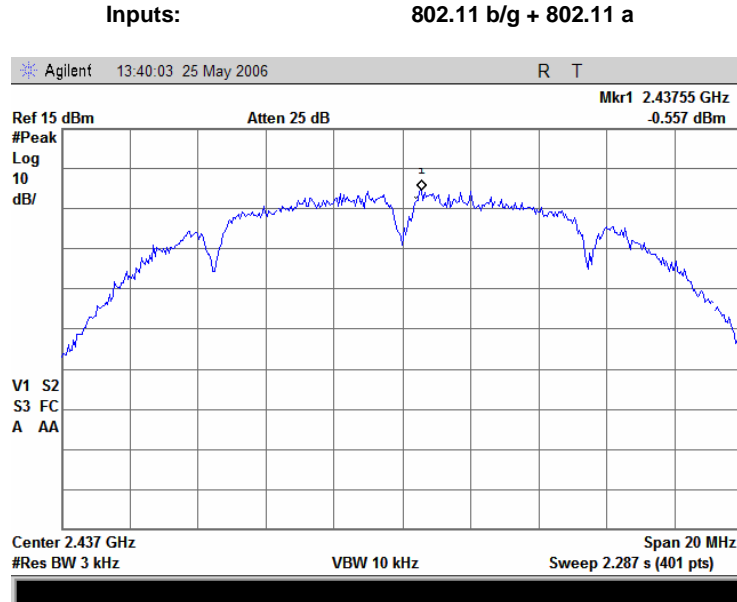

Plot 7.7.28 Peak spectral power density at mid frequency zoomed at the peak at 1 Mbps DSSS

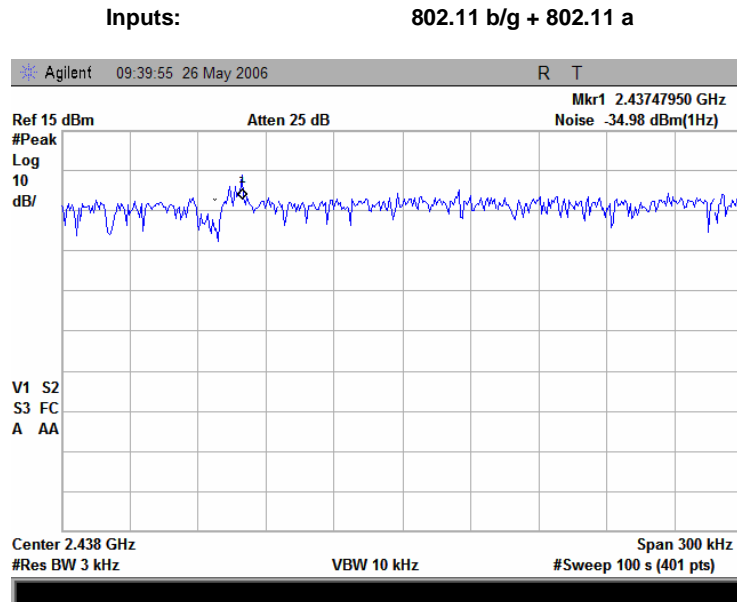

Test specification:	Section 15.247(d), Peak power density		
Test procedure:	FR Vol. 62, page 26243, Section 15.247(d)		
Test mode:	Compliance	Verdict:	PASS
Date & Time:	7/2/2006 6:20:52 PM		
Temperature: 24 °C	Air Pressure: 1015 hPa	Relative Humidity: 40 %	Power Supply: 120 VAC
Remarks:			

Plot 7.7.29 Peak spectral power density at high frequency within 6 dB band at 1 Mbps DSSS

Inputs: 802.11 b/g + 802.11 a

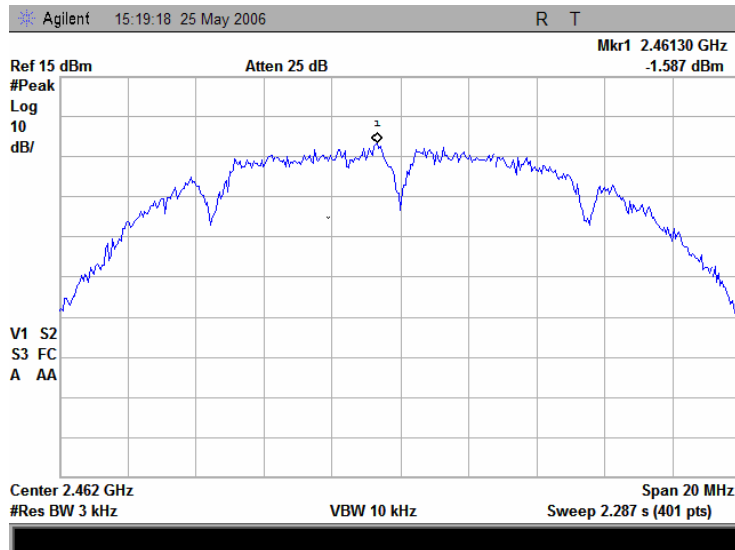

Plot 7.7.30 Peak spectral power density at high frequency zoomed at the peak at 1 Mbps DSSS

Inputs: 802.11 b/g + 802.11 a

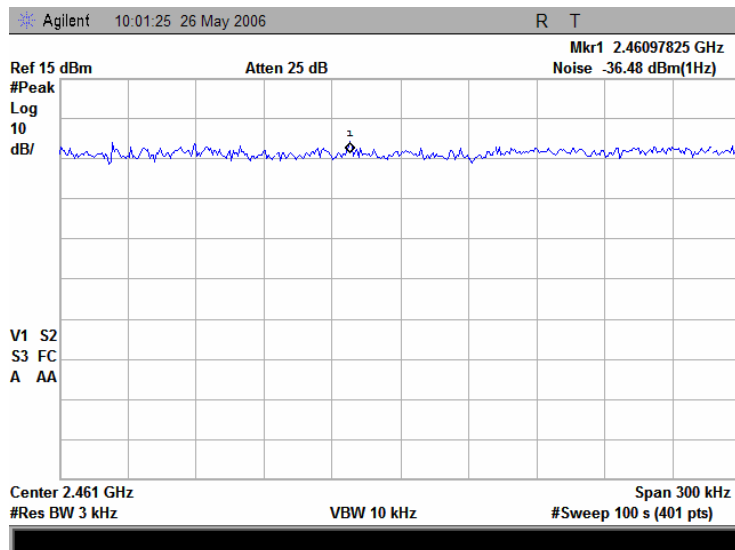

Test specification:	Section 15.247(d), Peak power density		
Test procedure:	FR Vol. 62, page 26243, Section 15.247(d)		
Test mode:	Compliance	Verdict:	PASS
Date & Time:	7/2/2006 6:20:52 PM		
Temperature: 24 °C	Air Pressure: 1015 hPa	Relative Humidity: 40 %	Power Supply: 120 VAC
Remarks:			

Plot 7.7.31 Peak spectral power density at low frequency within 6 dB band at 11 Mbps DSSS

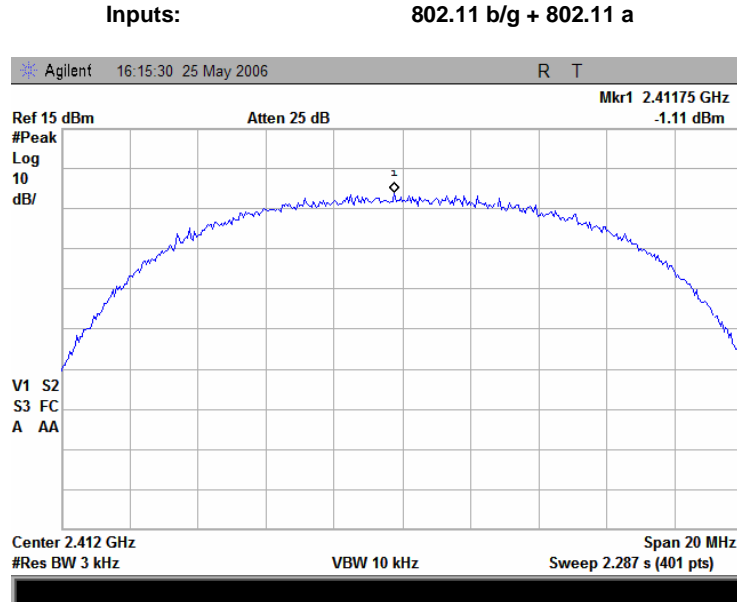

Plot 7.7.32 Peak spectral power density at low frequency zoomed at the peak at 11 Mbps DSSS

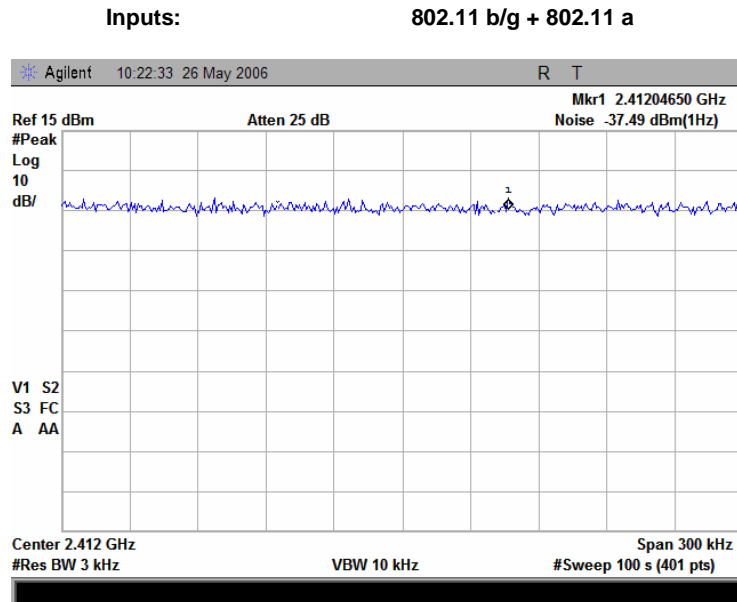

Test specification:	Section 15.247(d), Peak power density		
Test procedure:	FR Vol. 62, page 26243, Section 15.247(d)		
Test mode:	Compliance	Verdict:	PASS
Date & Time:	7/2/2006 6:20:52 PM		
Temperature: 24 °C	Air Pressure: 1015 hPa	Relative Humidity: 40 %	Power Supply: 120 VAC
Remarks:			

Plot 7.7.33 Peak spectral power density at mid frequency within 6 dB band at 11 Mbps DSSS

Inputs: 802.11 b/g + 802.11 a

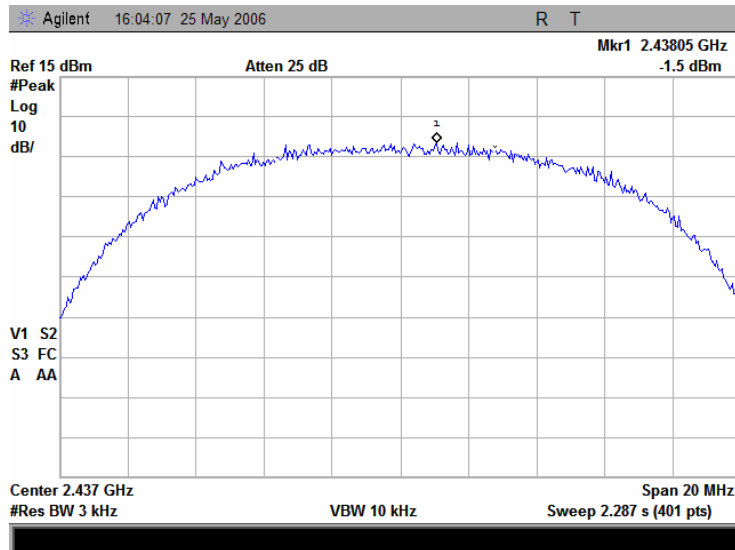

Plot 7.7.34 Peak spectral power density at mid frequency zoomed at the peak at 11 Mbps DSSS

Inputs: 802.11 b/g + 802.11 a

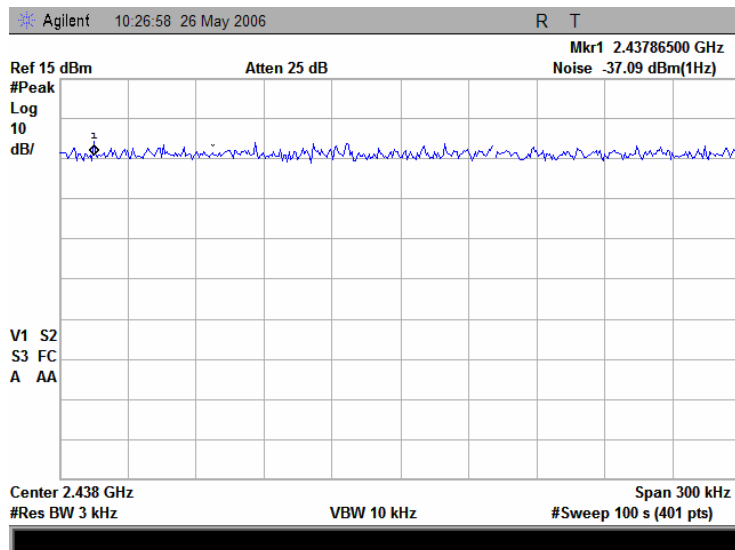

Test specification:	Section 15.247(d), Peak power density		
Test procedure:	FR Vol. 62, page 26243, Section 15.247(d)		
Test mode:	Compliance	Verdict:	PASS
Date & Time:	7/2/2006 6:20:52 PM		
Temperature: 24 °C	Air Pressure: 1015 hPa	Relative Humidity: 40 %	Power Supply: 120 VAC
Remarks:			

Plot 7.7.35 Peak spectral power density at high frequency within 6 dB band at 11 Mbps DSSS

Inputs: 802.11 b/g + 802.11 a

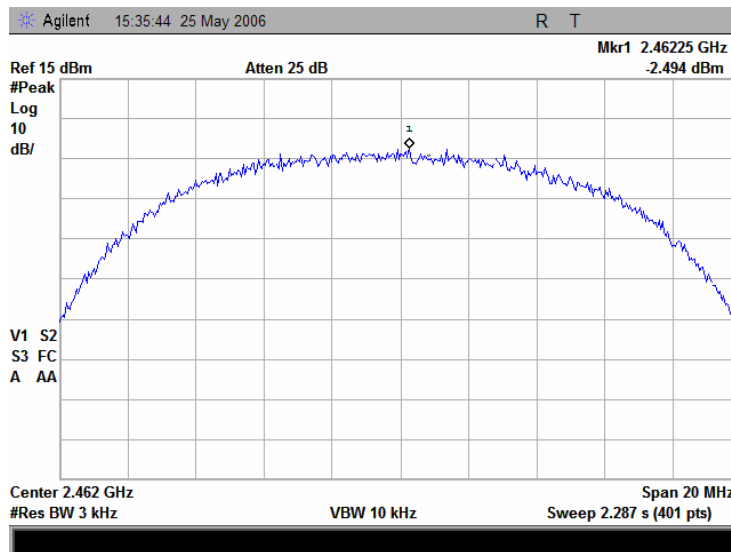

Plot 7.7.36 Peak spectral power density at high frequency zoomed at the peak at 11 Mbps DSSS

Inputs: 802.11 b/g + 802.11 a

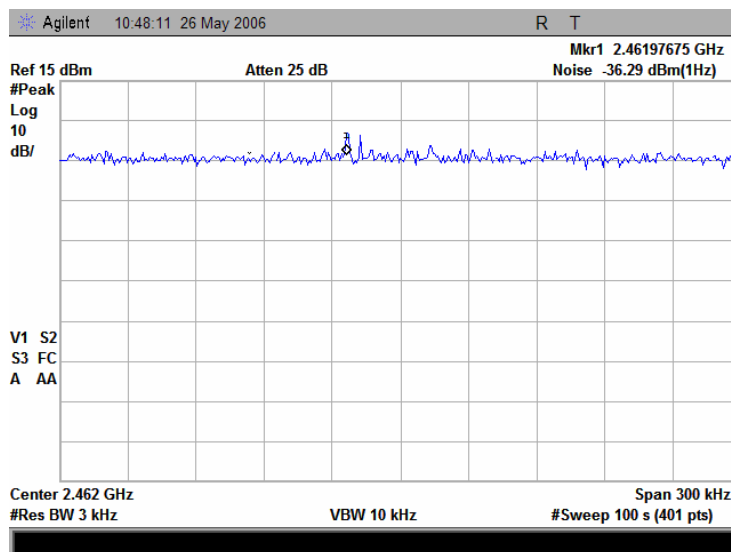

Test specification:	Section 15.247(d), Peak power density		
Test procedure:	FR Vol. 62, page 26243, Section 15.247(d)		
Test mode:	Compliance	Verdict:	PASS
Date & Time:	7/2/2006 6:20:52 PM		
Temperature: 24 °C	Air Pressure: 1015 hPa	Relative Humidity: 40 %	Power Supply: 120 VAC
Remarks:			

Plot 7.7.37 Peak spectral power density at low frequency within 6 dB band at 6 Mbps OFDM

Inputs: 802.11 b/g + 802.11 a

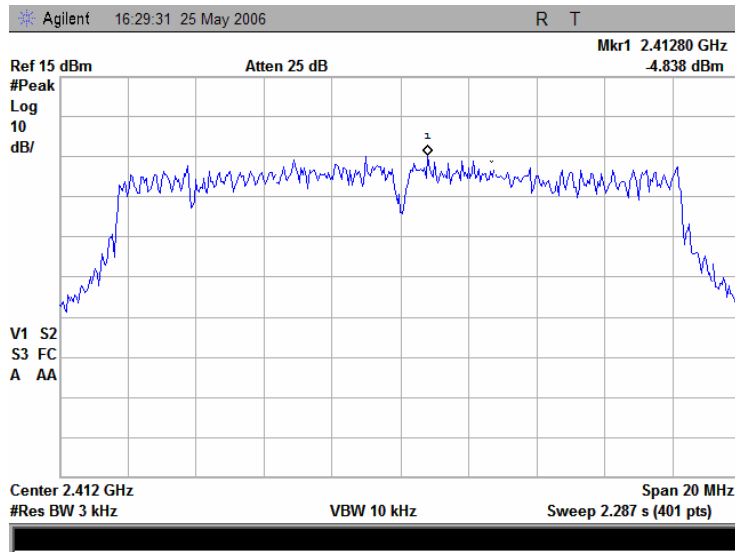

Plot 7.7.38 Peak spectral power density at low frequency zoomed at the peak at 6 Mbps OFDM

Inputs: 802.11 b/g + 802.11 a

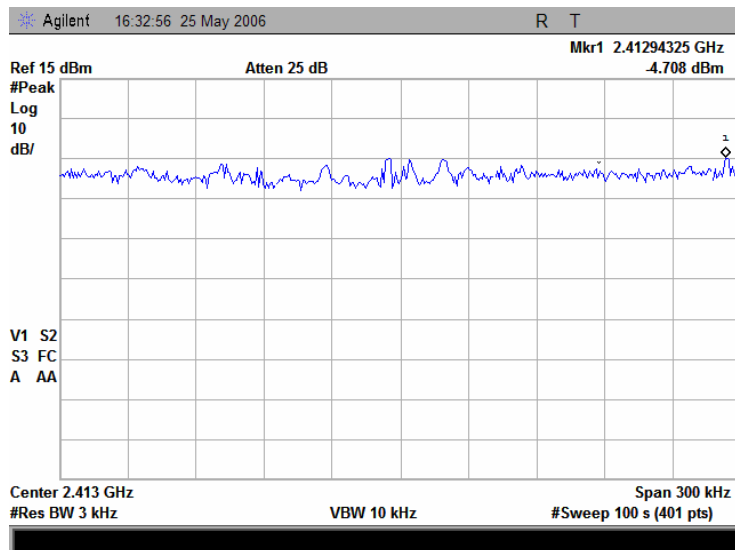

Test specification:	Section 15.247(d), Peak power density		
Test procedure:	FR Vol. 62, page 26243, Section 15.247(d)		
Test mode:	Compliance	Verdict:	PASS
Date & Time:	7/2/2006 6:20:52 PM		
Temperature: 24 °C	Air Pressure: 1015 hPa	Relative Humidity: 40 %	Power Supply: 120 VAC
Remarks:			

Plot 7.7.39 Peak spectral power density at mid frequency within 6 dB band at 6 Mbps OFDM

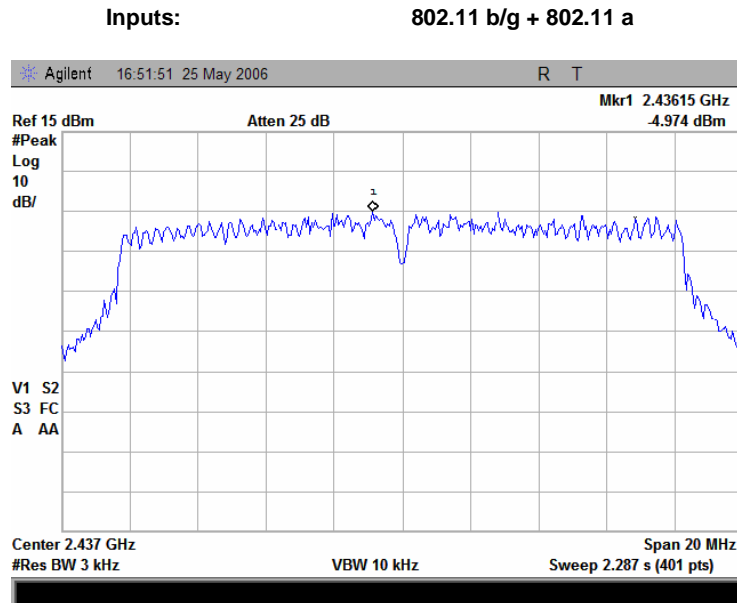

Plot 7.7.40 Peak spectral power density at mid frequency zoomed at the peak at 6 Mbps OFDM

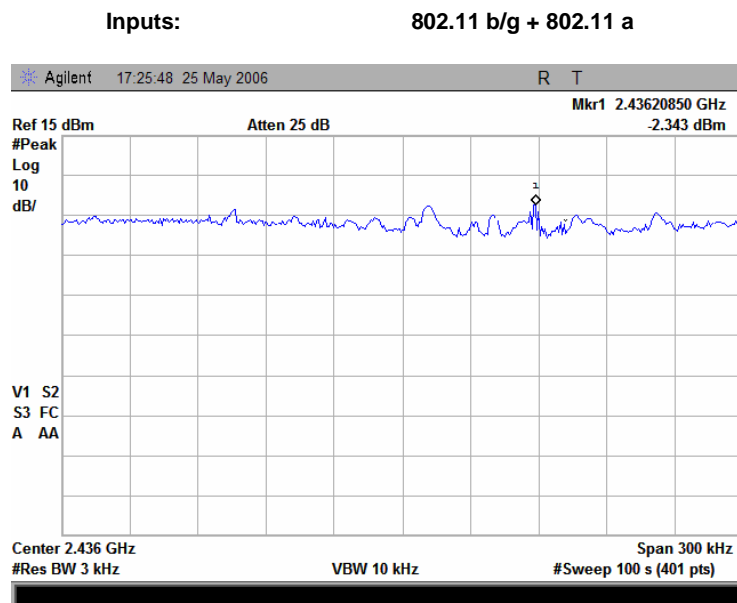

Test specification:	Section 15.247(d), Peak power density		
Test procedure:	FR Vol. 62, page 26243, Section 15.247(d)		
Test mode:	Compliance	Verdict:	PASS
Date & Time:	7/2/2006 6:20:52 PM		
Temperature: 24 °C	Air Pressure: 1015 hPa	Relative Humidity: 40 %	Power Supply: 120 VAC
Remarks:			

Plot 7.7.41 Peak spectral power density at high frequency within 6 dB band at 6 Mbps OFDM

Inputs: 802.11 b/g + 802.11 a

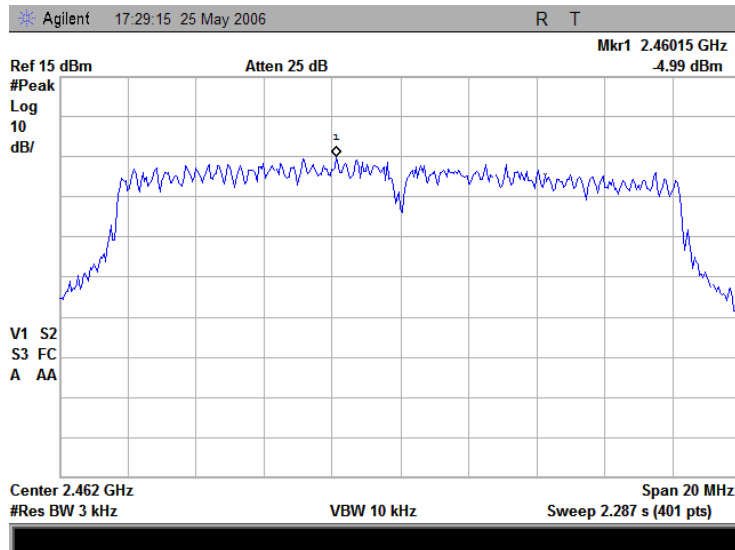

Plot 7.7.42 Peak spectral power density at high frequency zoomed at the peak at 6 Mbps OFDM

Inputs: 802.11 b/g + 802.11 a

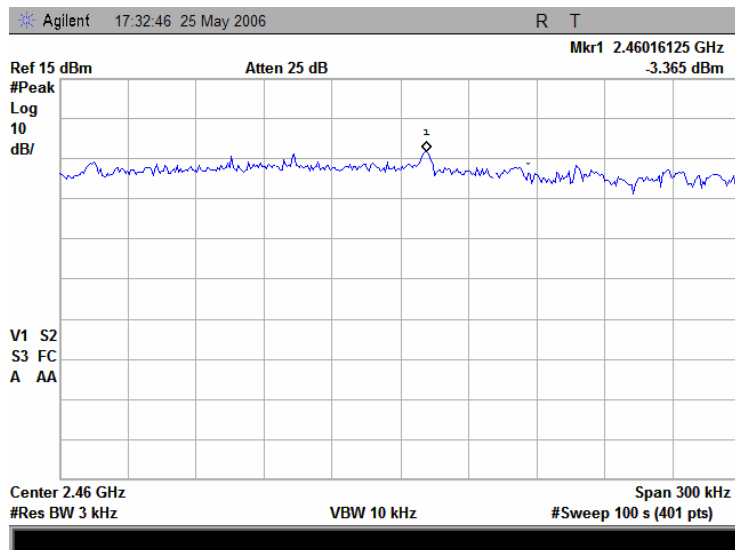

Test specification:	Section 15.247(d), Peak power density		
Test procedure:	FR Vol. 62, page 26243, Section 15.247(d)		
Test mode:	Compliance	Verdict:	PASS
Date & Time:	7/2/2006 6:20:52 PM		
Temperature: 24 °C	Air Pressure: 1015 hPa	Relative Humidity: 40 %	Power Supply: 120 VAC
Remarks:			

Plot 7.7.43 Peak spectral power density at low frequency within 6 dB band at 54 Mbps OFDM

Inputs: 802.11 b/g + 802.11 a

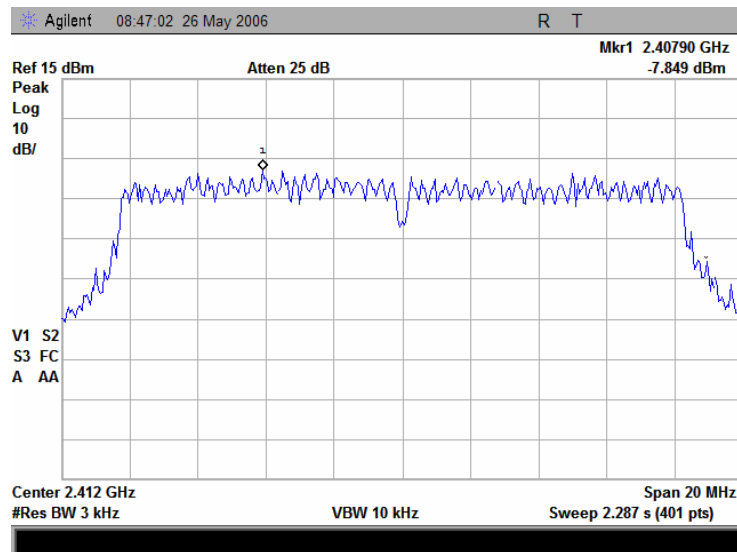

Plot 7.7.44 Peak spectral power density at low frequency zoomed at the peak at 54 Mbps OFDM

Inputs: 802.11 b/g + 802.11 a

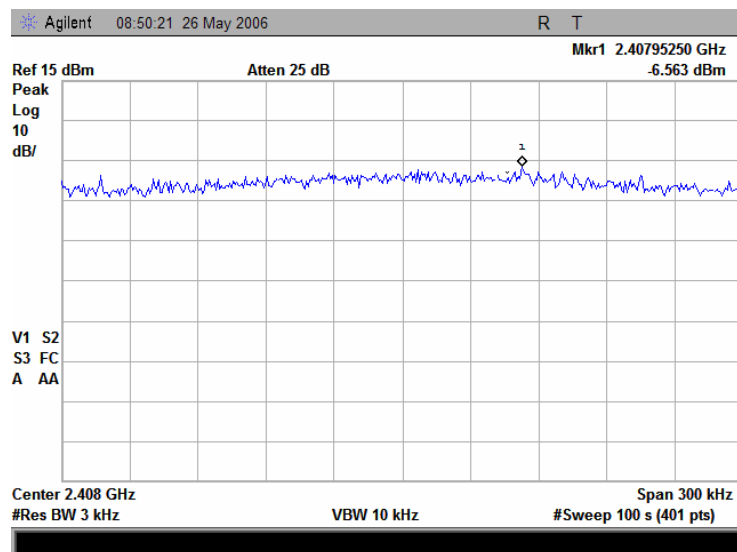

Test specification:	Section 15.247(d), Peak power density		
Test procedure:	FR Vol. 62, page 26243, Section 15.247(d)		
Test mode:	Compliance	Verdict:	PASS
Date & Time:	7/2/2006 6:20:52 PM		
Temperature: 24 °C	Air Pressure: 1015 hPa	Relative Humidity: 40 %	Power Supply: 120 VAC
Remarks:			

Plot 7.7.45 Peak spectral power density at mid frequency within 6 dB band at 54 Mbps OFDM

Inputs: 802.11 b/g + 802.11 a

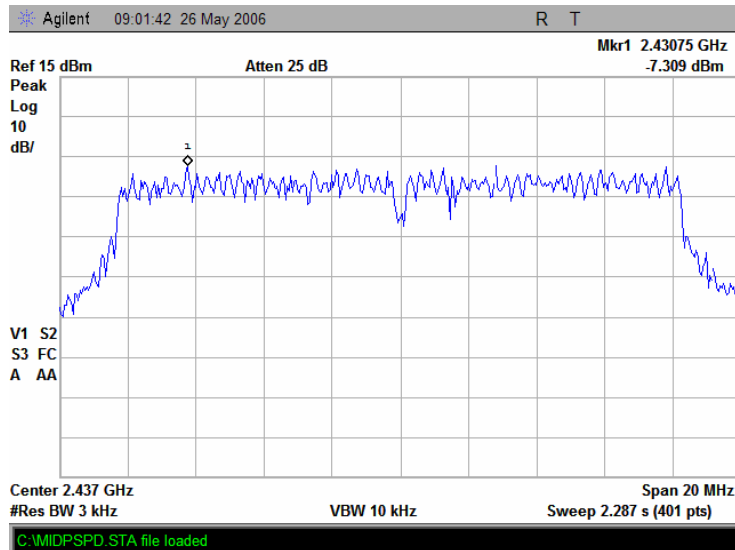

Plot 7.7.46 Peak spectral power density at mid frequency zoomed at the peak at 54 Mbps OFDM

Inputs: 802.11 b/g + 802.11 a

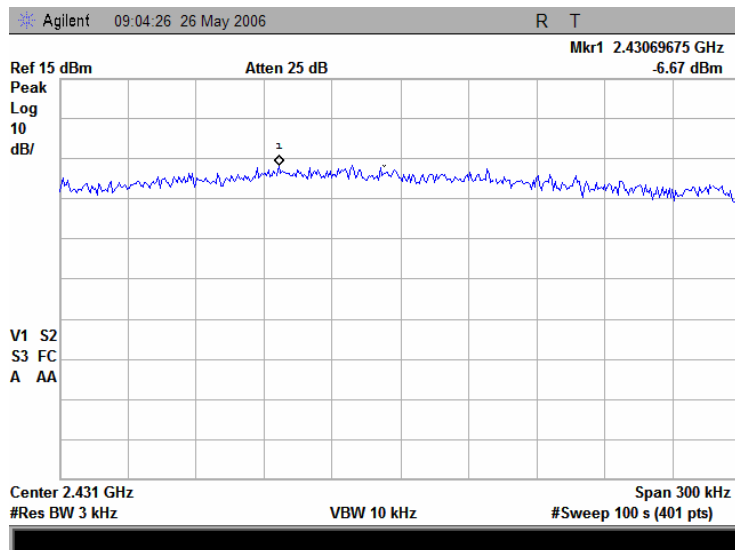

Test specification:	Section 15.247(d), Peak power density		
Test procedure:	FR Vol. 62, page 26243, Section 15.247(d)		
Test mode:	Compliance	Verdict:	PASS
Date & Time:	7/2/2006 6:20:52 PM		
Temperature: 24 °C	Air Pressure: 1015 hPa	Relative Humidity: 40 %	Power Supply: 120 VAC
Remarks:			

Plot 7.7.47 Peak spectral power density at high frequency within 6 dB band at 54 Mbps OFDM

Inputs: 802.11 b/g + 802.11 a

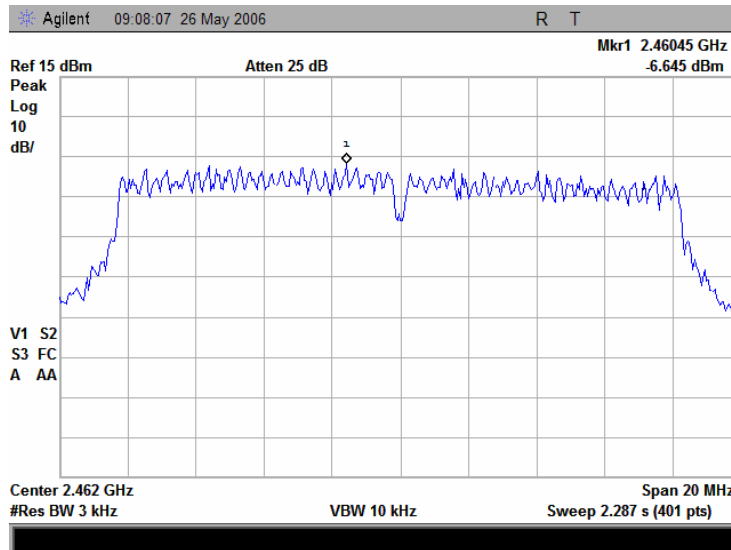

Plot 7.7.48 Peak spectral power density at high frequency zoomed at the peak at 54 Mbps OFDM

Inputs: 802.11 b/g + 802.11 a

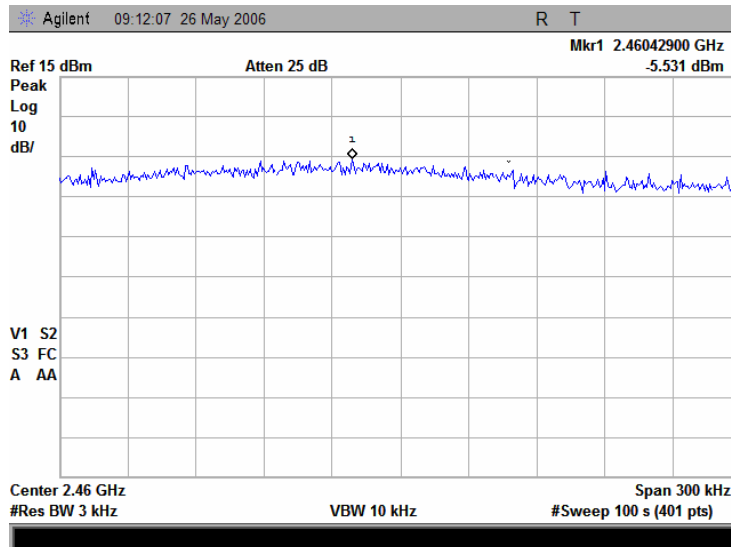

Test specification:	Section 15.247(d), Peak power density		
Test procedure:	FR Vol. 62, page 26243, Section 15.247(d)		
Test mode:	Compliance	Verdict:	PASS
Date & Time:	7/2/2006 6:20:52 PM		
Temperature: 24 °C	Air Pressure: 1015 hPa	Relative Humidity: 40 %	Power Supply: 120 VAC
Remarks:			

Plot 7.7.49 Peak spectral power density at low frequency within 6 dB band at 1 Mbps DSSS

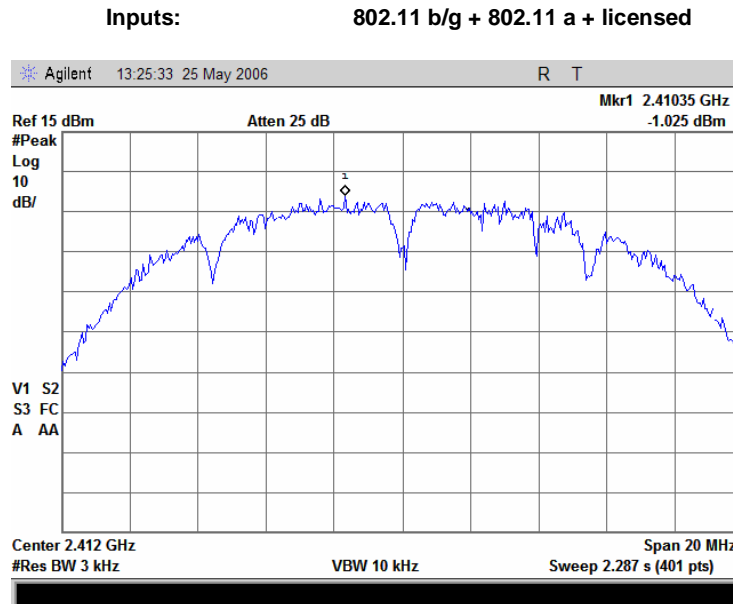

Plot 7.7.50 Peak spectral power density at low frequency zoomed at the peak at 1 Mbps DSSS

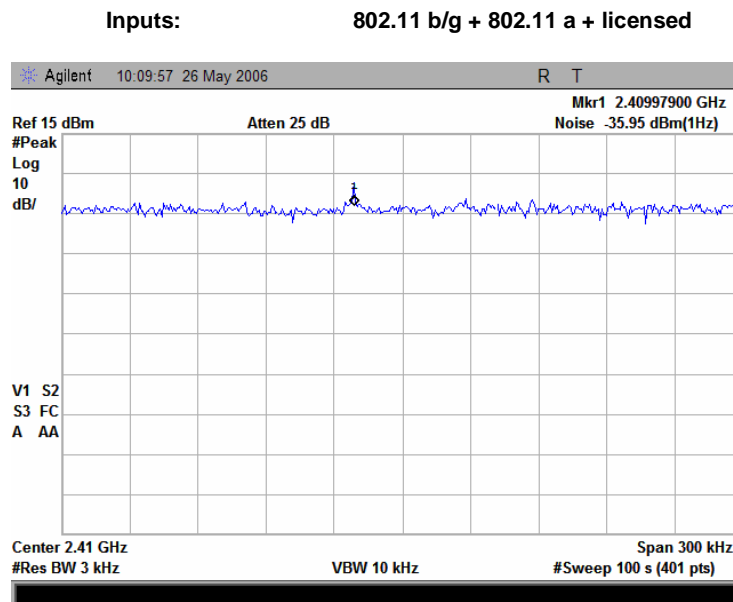

Test specification:	Section 15.247(d), Peak power density		
Test procedure:	FR Vol. 62, page 26243, Section 15.247(d)		
Test mode:	Compliance	Verdict:	PASS
Date & Time:	7/2/2006 6:20:52 PM		
Temperature: 24 °C	Air Pressure: 1015 hPa	Relative Humidity: 40 %	Power Supply: 120 VAC
Remarks:			

Plot 7.7.51 Peak spectral power density at mid frequency within 6 dB band at 1 Mbps DSSS

Inputs: 802.11 b/g + 802.11 a + licensed

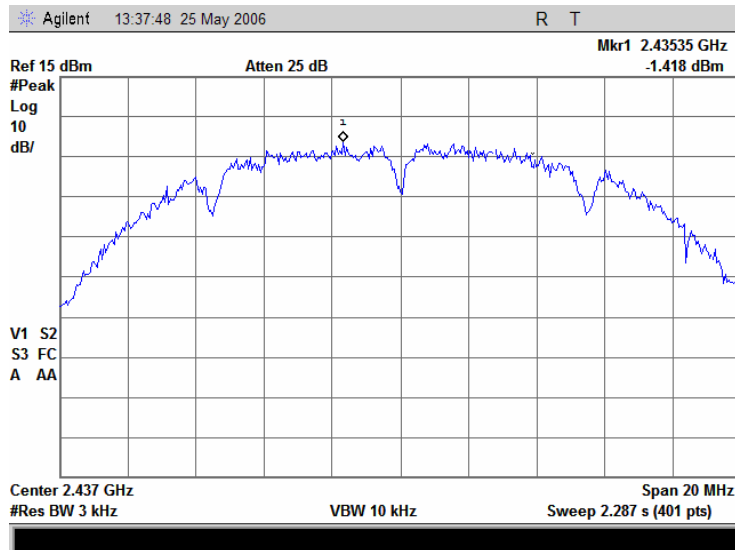

Plot 7.7.52 Peak spectral power density at mid frequency zoomed at the peak at 1 Mbps DSSS

Inputs: 802.11 b/g + 802.11 a + licensed

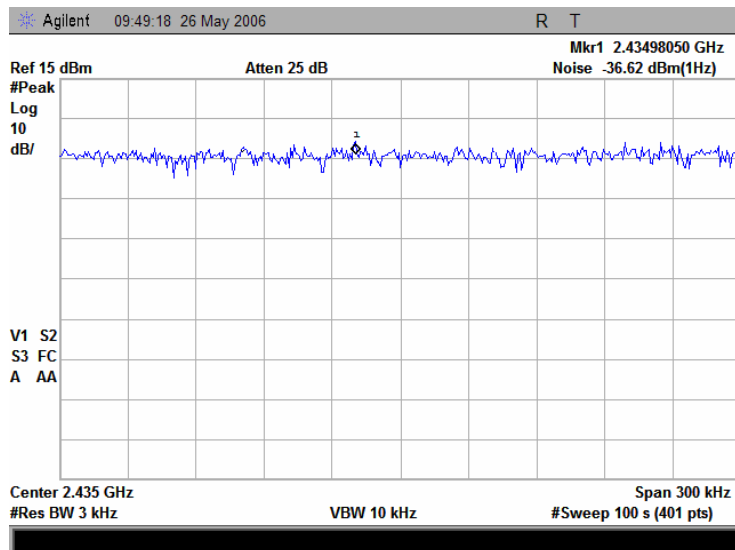

Test specification:	Section 15.247(d), Peak power density		
Test procedure:	FR Vol. 62, page 26243, Section 15.247(d)		
Test mode:	Compliance	Verdict:	PASS
Date & Time:	7/2/2006 6:20:52 PM		
Temperature: 24 °C	Air Pressure: 1015 hPa	Relative Humidity: 40 %	Power Supply: 120 VAC
Remarks:			

Plot 7.7.53 Peak spectral power density at high frequency within 6 dB band at 1 Mbps DSSS

Inputs: 802.11 b/g + 802.11 a + licensed

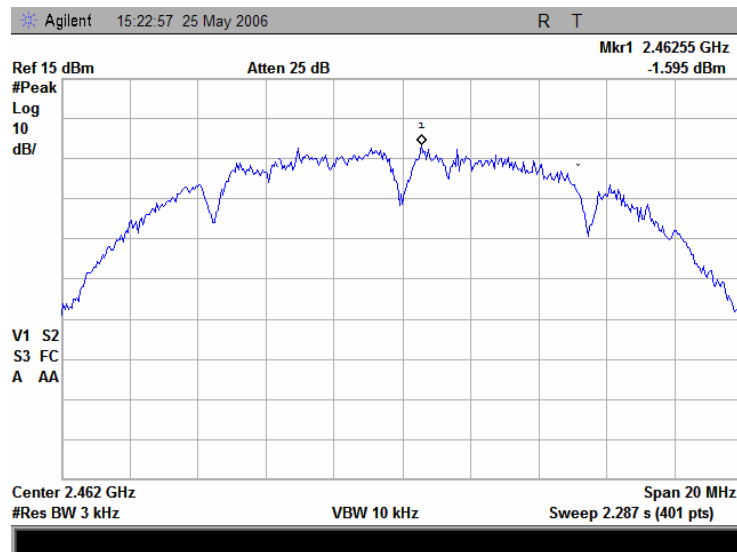

Plot 7.7.54 Peak spectral power density at high frequency zoomed at the peak at 1 Mbps DSSS

Inputs: 802.11 b/g + 802.11 a + licensed

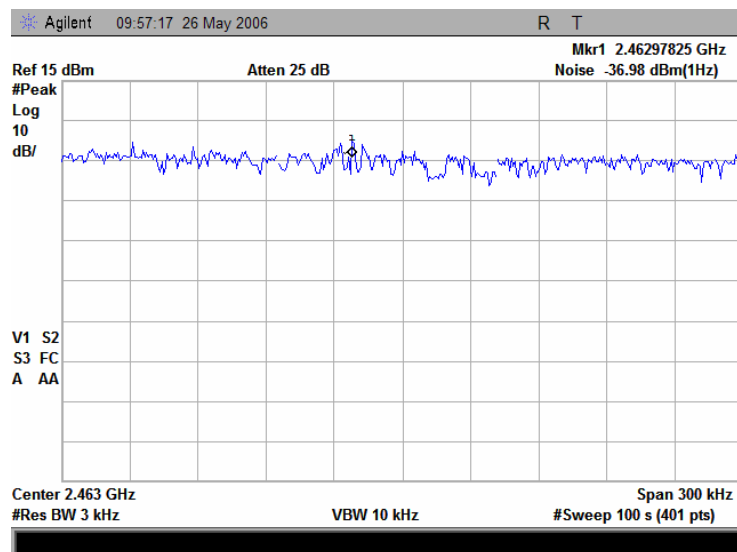

Test specification:	Section 15.247(d), Peak power density		
Test procedure:	FR Vol. 62, page 26243, Section 15.247(d)		
Test mode:	Compliance	Verdict:	PASS
Date & Time:	7/2/2006 6:20:52 PM		
Temperature: 24 °C	Air Pressure: 1015 hPa	Relative Humidity: 40 %	Power Supply: 120 VAC
Remarks:			

Plot 7.7.55 Peak spectral power density at low frequency within 6 dB band at 11 Mbps DSSS

Inputs: 802.11 b/g + 802.11 a + licensed

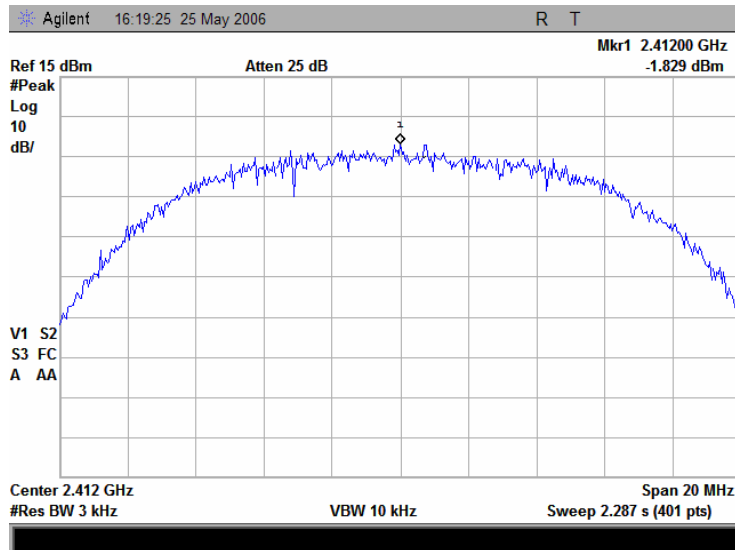

Plot 7.7.56 Peak spectral power density at low frequency zoomed at the peak at 11 Mbps DSSS

Inputs: 802.11 b/g + 802.11 a + licensed

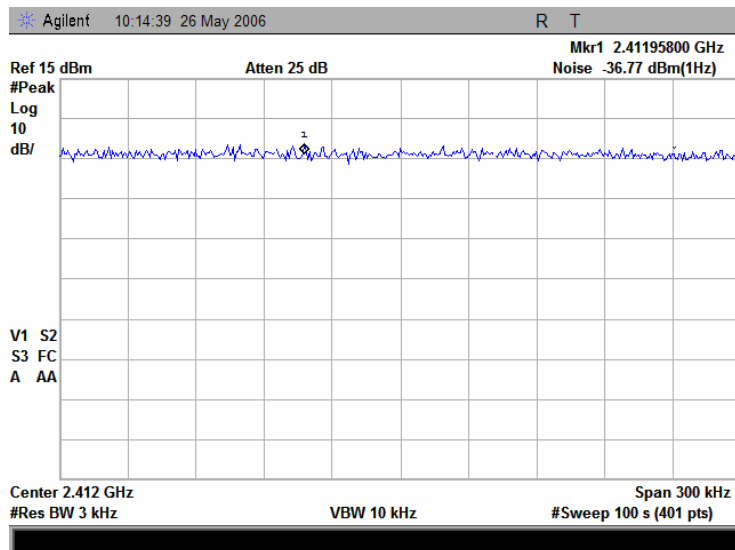

Test specification:	Section 15.247(d), Peak power density		
Test procedure:	FR Vol. 62, page 26243, Section 15.247(d)		
Test mode:	Compliance	Verdict:	PASS
Date & Time:	7/2/2006 6:20:52 PM		
Temperature: 24 °C	Air Pressure: 1015 hPa	Relative Humidity: 40 %	Power Supply: 120 VAC
Remarks:			

Plot 7.7.57 Peak spectral power density at mid frequency within 6 dB band at 11 Mbps DSSS

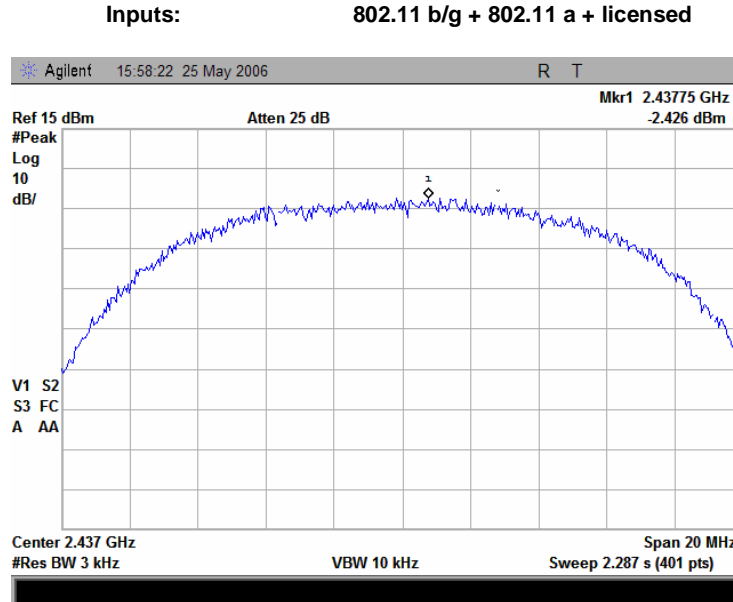

Plot 7.7.58 Peak spectral power density at mid frequency zoomed at the peak at 11 Mbps DSSS

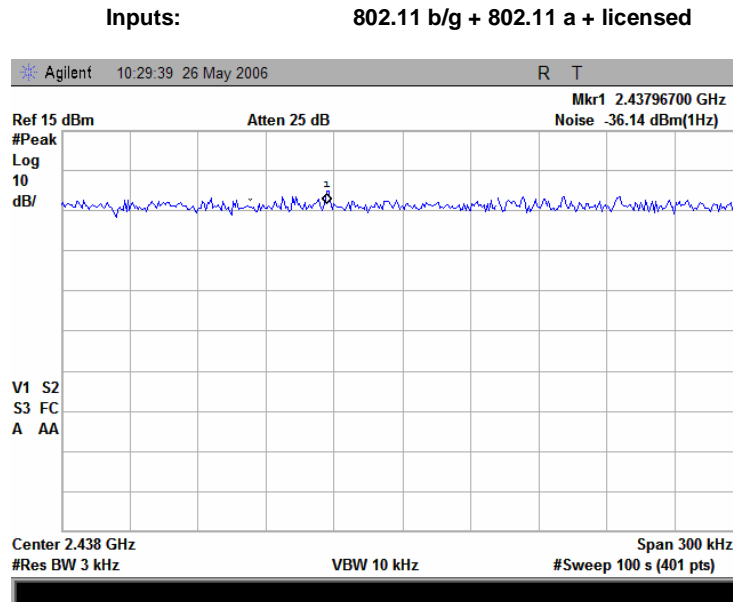

Test specification:	Section 15.247(d), Peak power density		
Test procedure:	FR Vol. 62, page 26243, Section 15.247(d)		
Test mode:	Compliance	Verdict:	PASS
Date & Time:	7/2/2006 6:20:52 PM		
Temperature: 24 °C	Air Pressure: 1015 hPa	Relative Humidity: 40 %	Power Supply: 120 VAC
Remarks:			

Plot 7.7.59 Peak spectral power density at high frequency within 6 dB band at 11 Mbps DSSS

Inputs: 802.11 b/g + 802.11 a + licensed

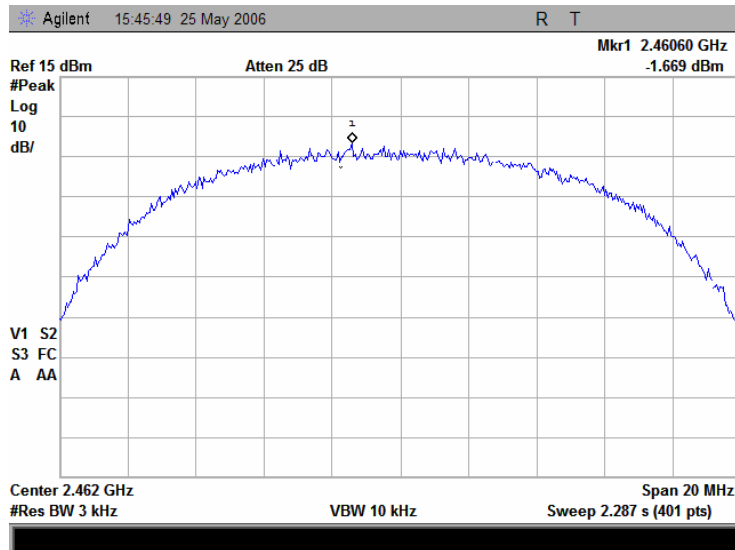

Plot 7.7.60 Peak spectral power density at high frequency zoomed at the peak at 11 Mbps DSSS

Inputs: 802.11 b/g + 802.11 a + licensed

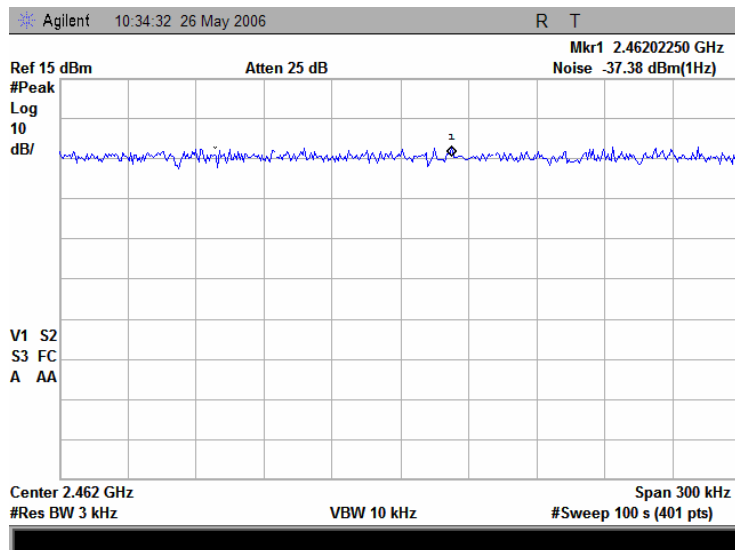

Test specification:	Section 15.247(d), Peak power density		
Test procedure:	FR Vol. 62, page 26243, Section 15.247(d)		
Test mode:	Compliance	Verdict:	PASS
Date & Time:	7/2/2006 6:20:52 PM		
Temperature: 24 °C	Air Pressure: 1015 hPa	Relative Humidity: 40 %	Power Supply: 120 VAC
Remarks:			

Plot 7.7.61 Peak spectral power density at low frequency within 6 dB band at 6 Mbps OFDM

Inputs: 802.11 b/g + 802.11 a + licensed

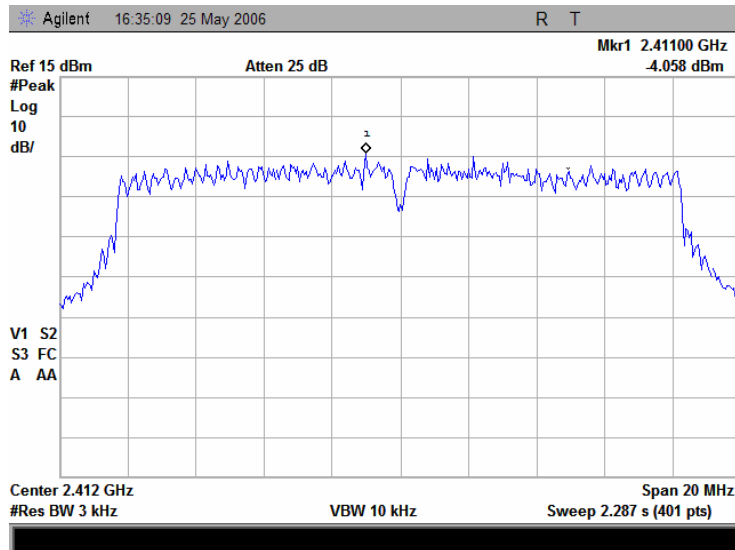

Plot 7.7.62 Peak spectral power density at low frequency zoomed at the peak at 6 Mbps OFDM

Inputs: 802.11 b/g + 802.11 a + licensed

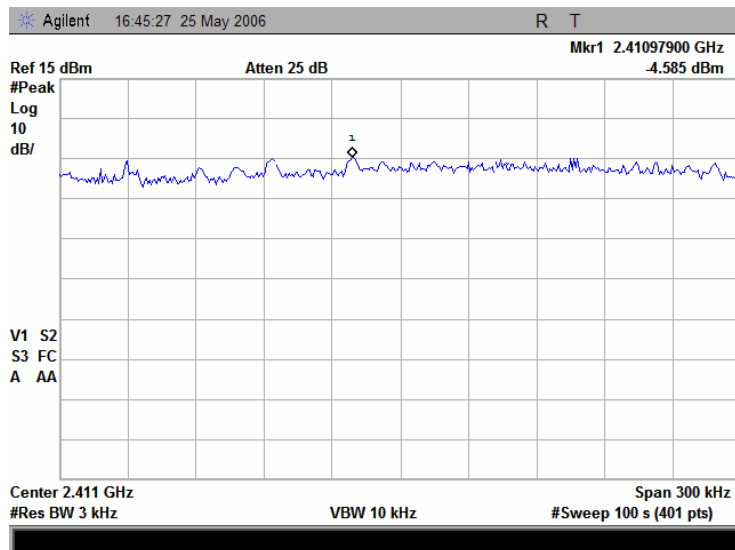

Test specification:	Section 15.247(d), Peak power density		
Test procedure:	FR Vol. 62, page 26243, Section 15.247(d)		
Test mode:	Compliance	Verdict:	PASS
Date & Time:	7/2/2006 6:20:52 PM		
Temperature: 24 °C	Air Pressure: 1015 hPa	Relative Humidity: 40 %	Power Supply: 120 VAC
Remarks:			

Plot 7.7.63 Peak spectral power density at mid frequency within 6 dB band at 6 Mbps OFDM

Inputs: 802.11 b/g + 802.11 a + licensed

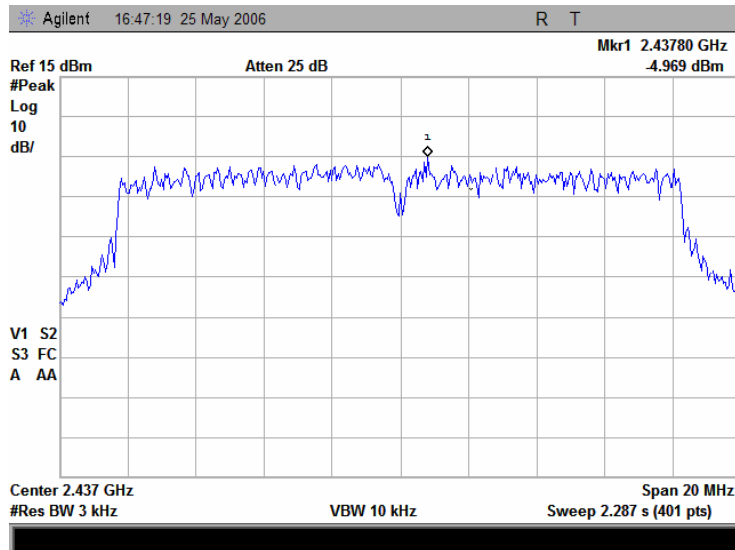

Plot 7.7.64 Peak spectral power density at mid frequency zoomed at the peak at 6 Mbps OFDM

Inputs: 802.11 b/g + 802.11 a + licensed

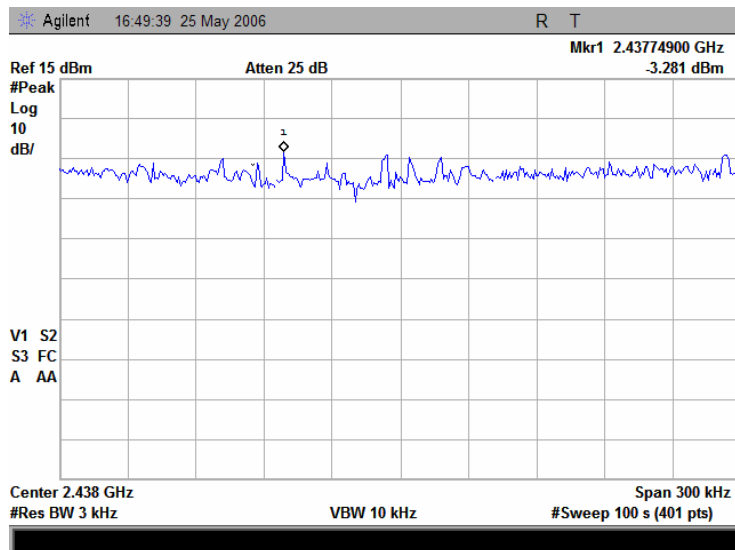

Test specification:	Section 15.247(d), Peak power density		
Test procedure:	FR Vol. 62, page 26243, Section 15.247(d)		
Test mode:	Compliance	Verdict:	PASS
Date & Time:	7/2/2006 6:20:52 PM		
Temperature: 24 °C	Air Pressure: 1015 hPa	Relative Humidity: 40 %	Power Supply: 120 VAC
Remarks:			

Plot 7.7.65 Peak spectral power density at high frequency within 6 dB band at 6 Mbps OFDM

Inputs: 802.11 b/g + 802.11 a + licensed

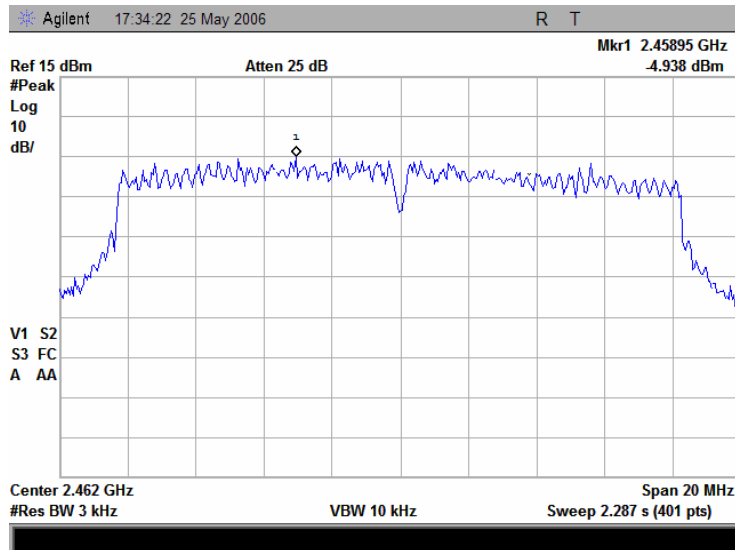

Plot 7.7.66 Peak spectral power density at high frequency zoomed at the peak at 6 Mbps OFDM

Inputs: 802.11 b/g + 802.11 a + licensed

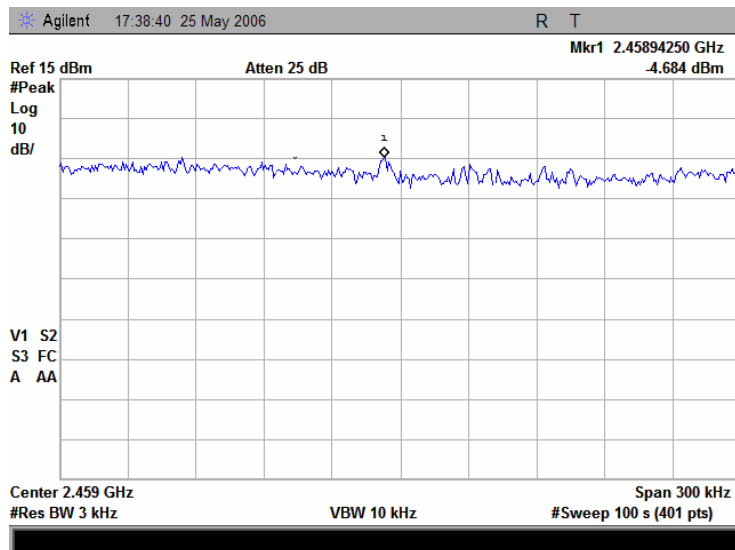

Test specification:	Section 15.247(d), Peak power density		
Test procedure:	FR Vol. 62, page 26243, Section 15.247(d)		
Test mode:	Compliance	Verdict:	PASS
Date & Time:	7/2/2006 6:20:52 PM		
Temperature: 24 °C	Air Pressure: 1015 hPa	Relative Humidity: 40 %	Power Supply: 120 VAC
Remarks:			

Plot 7.7.67 Peak spectral power density at low frequency within 6 dB band at 54 Mbps OFDM

Inputs: 802.11 b/g + 802.11 a + licensed

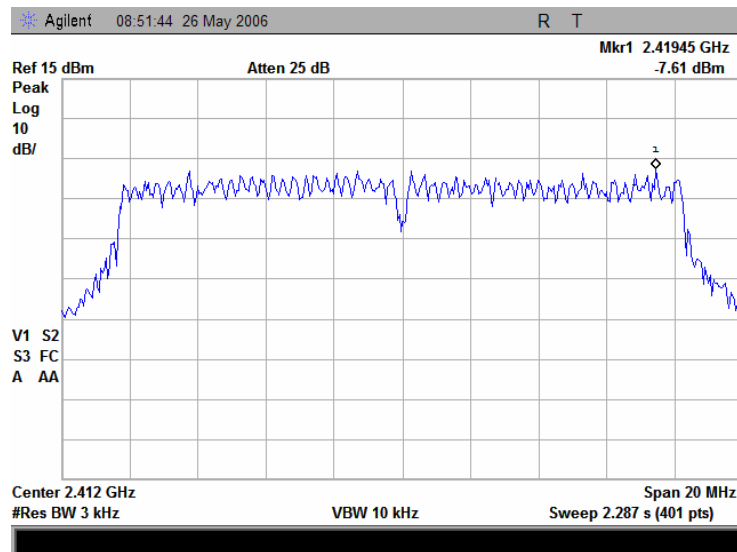

Plot 7.7.68 Peak spectral power density at low frequency zoomed at the peak at 54 Mbps OFDM

Inputs: 802.11 b/g + 802.11 a + licensed

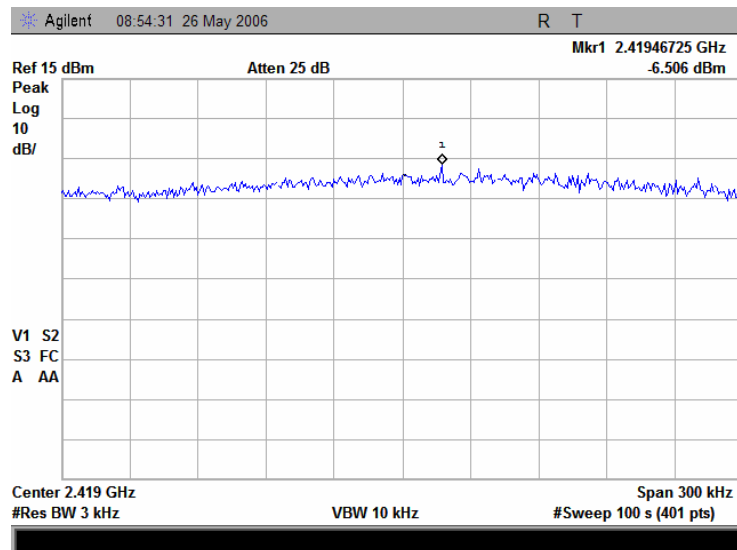

Test specification:	Section 15.247(d), Peak power density		
Test procedure:	FR Vol. 62, page 26243, Section 15.247(d)		
Test mode:	Compliance	Verdict:	PASS
Date & Time:	7/2/2006 6:20:52 PM		
Temperature: 24 °C	Air Pressure: 1015 hPa	Relative Humidity: 40 %	Power Supply: 120 VAC
Remarks:			

Plot 7.7.69 Peak spectral power density at mid frequency within 6 dB band at 54 Mbps OFDM

Inputs: 802.11 b/g + 802.11 a + licensed

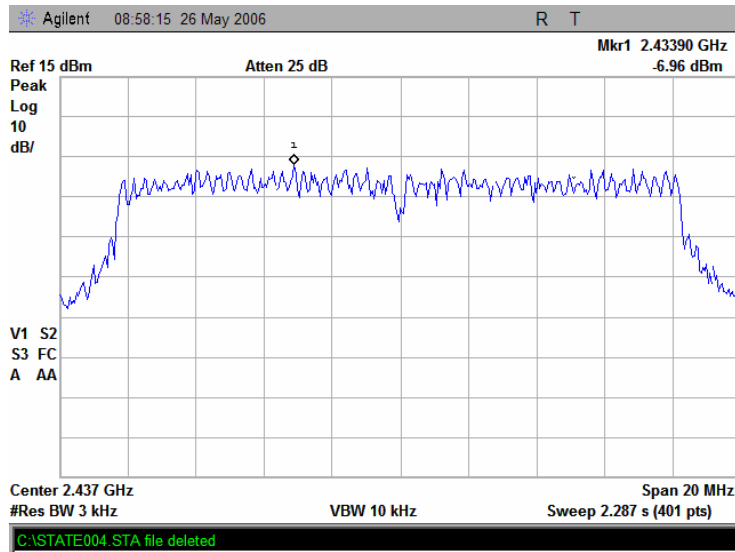

Plot 7.7.70 Peak spectral power density at mid frequency zoomed at the peak at 54 Mbps OFDM

Inputs: 802.11 b/g + 802.11 a + licensed

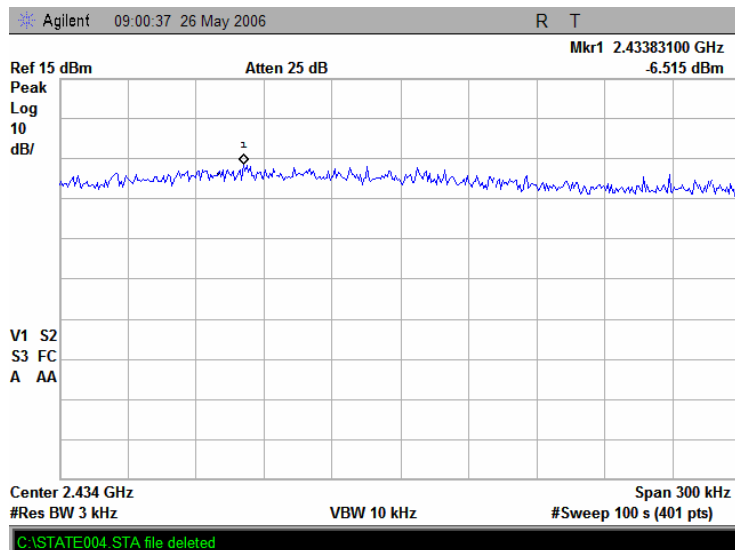

Test specification:	Section 15.247(d), Peak power density		
Test procedure:	FR Vol. 62, page 26243, Section 15.247(d)		
Test mode:	Compliance	Verdict:	PASS
Date & Time:	7/2/2006 6:20:52 PM		
Temperature: 24 °C	Air Pressure: 1015 hPa	Relative Humidity: 40 %	Power Supply: 120 VAC
Remarks:			

Plot 7.7.71 Peak spectral power density at high frequency within 6 dB band at 54 Mbps OFDM

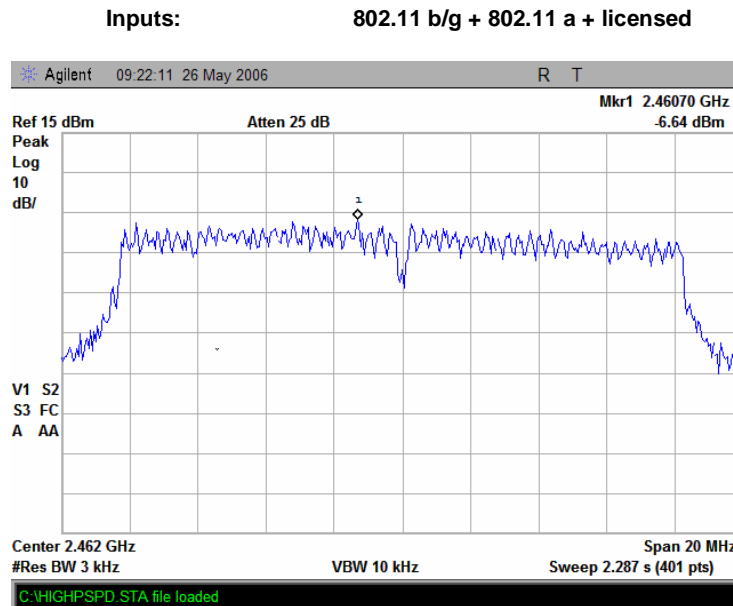

Plot 7.7.72 Peak spectral power density at high frequency zoomed at the peak at 54 Mbps OFDM

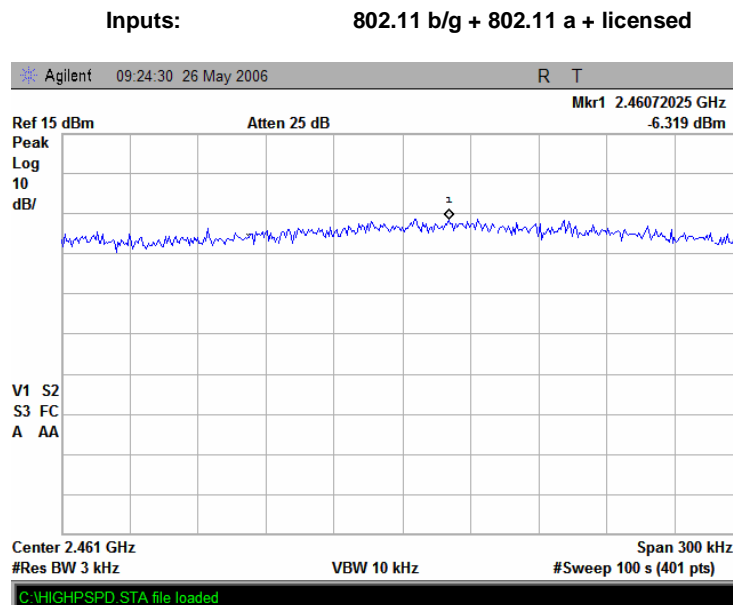

Test specification:		Section 15.207(a), 15.107, Conducted emission	
Test procedure:		ANSI C63.4, Section 13.1.3, Sections 11.5 and 12.1.3	
Test mode:	Compliance	Verdict:	PASS
Date & Time:	6/4/2006 10:02:28 AM		
Temperature: 26 °C	Air Pressure: 1019 hPa	Relative Humidity: 37 %	Power Supply: 120VAC
Remarks: a+b/g+licened			

7.8 Conducted emissions

7.8.1 General

This test was performed to measure common mode conducted emissions at the power port. Specification test limits are given in Table 7.8.1.

Table 7.8.1 Limits for conducted emissions

Frequency, MHz	Class B limit, dB(μV)	
	QP	AVRG
0.15 - 0.5	66 - 56*	56 - 46*
0.5 - 5.0	56	46
5.0 - 30	60	50

* The limit decreases linearly with the logarithm of frequency.

7.8.2 Test procedure

7.8.2.1 The EUT was set up as shown in Figure 7.8.1, energized and the performance check was conducted.

7.8.2.2 The measurements were performed at power terminals with the LISN, connected to a spectrum analyzer in the frequency range referred to in Table 7.8.2. Unused coaxial connector of the LISN was terminated with 50 Ohm. Quasi-peak and average detectors were used throughout the testing.

7.8.2.3 The position of the device cables was varied to determine maximum emission level.

Test specification:	Section 15.207(a), 15.107, Conducted emission		
Test procedure:	ANSI C63.4, Section 13.1.3, Sections 11.5 and 12.1.3		
Test mode:	Compliance	Verdict:	PASS
Date & Time:	6/4/2006 10:02:28 AM		
Temperature: 26 °C	Air Pressure: 1019 hPa	Relative Humidity: 37 %	Power Supply: 120VAC
Remarks: a+b/g+licened			

Figure 7.8.1 Setup for conducted emission measurements, table-top equipment

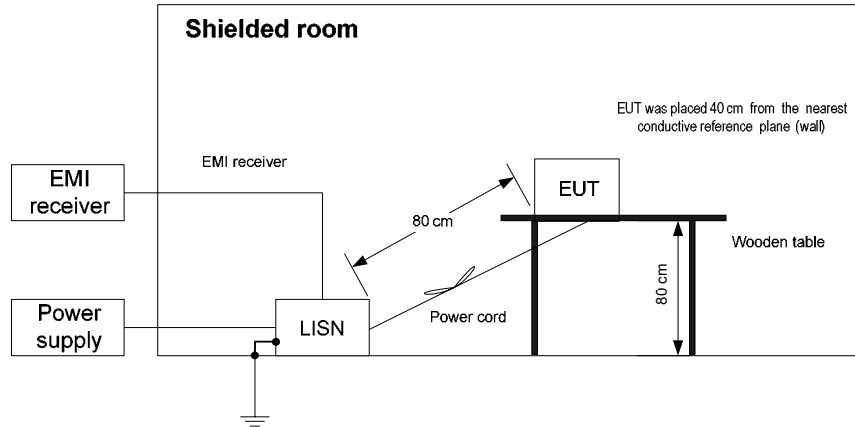

Test specification:		Section 15.207(a), 15.107, Conducted emission	
Test procedure:		ANSI C63.4, Section 13.1.3, Sections 11.5 and 12.1.3	
Test mode:	Compliance	Verdict:	PASS
Date & Time:	6/4/2006 10:02:28 AM		
Temperature: 26 °C	Air Pressure: 1019 hPa	Relative Humidity: 37 %	Power Supply: 120VAC
Remarks: a+b/g/licened			

Table 7.8.2 Conducted emission test results

LINE: **AC mains to MA850**
EUT OPERATING MODE: Transmit
EUT SET UP: TABLE-TOP
TEST SITE: SHIELDED ROOM
DETECTORS USED: PEAK / QUASI-PEAK / AVERAGE
FREQUENCY RANGE: 150 kHz - 30 MHz
RESOLUTION BANDWIDTH: 9 kHz

Frequency, MHz	Peak emission, dB(μV)	Quasi-peak			Average			Line ID	Verdict
		Measured emission, dB(μV)	Limit, dB(μV)	Margin, dB*	Measured emission, dB(μV)	Limit, dB(μV)	Margin, dB*		
0.206201	51.68	48.24	63.42	-15.18	31.09	53.42	-22.33	L1	Pass
0.224605	51.03	49.14	62.71	-13.57	34.98	52.71	-17.73		
0.226060	50.70	49.29	62.65	-13.36	34.09	52.65	-18.56		
0.338878	44.98	43.47	59.29	-15.82	30.59	49.29	-18.70		
0.962734	43.17	40.10	56.00	-15.90	38.66	46.00	-7.34		
1.157897	47.51	45.77	56.00	-10.23	45.11	46.00	-0.89	L2	Pass
0.209831	51.07	47.97	63.28	-15.31	30.36	53.28	-22.92		
0.224583	49.73	47.84	62.71	-14.87	33.95	52.71	-18.76		
0.309757	43.48	39.00	59.98	-20.98	22.19	49.98	-27.79		
0.963516	43.15	40.01	56.00	-15.99	38.66	46.00	-7.34		
1.157094	46.85	45.60	56.00	-10.40	44.95	46.00	-1.05		

Test specification:		Section 15.207(a), 15.107, Conducted emission	
Test procedure:		ANSI C63.4, Section 13.1.3, Sections 11.5 and 12.1.3	
Test mode:	Compliance	Verdict:	PASS
Date & Time:	6/4/2006 10:02:28 AM		
Temperature: 26 °C	Air Pressure: 1019 hPa	Relative Humidity: 37 %	Power Supply: 120VAC
Remarks: a+b/g/licened			

LINE: AC mains to CISCO A.P
EUT OPERATING MODE: Transmit
EUT SET UP: TABLE-TOP
TEST SITE: SHIELDED ROOM
DETECTORS USED: PEAK / QUASI-PEAK / AVERAGE
FREQUENCY RANGE: 150 kHz - 30 MHz
RESOLUTION BANDWIDTH: 9 kHz

Frequency, MHz	Peak emission, dB(μV)	Quasi-peak			Average			Line ID	Verdict
		Measured emission, dB(μV)	Limit, dB(μV)	Margin, dB*	Measured emission, dB(μV)	Limit, dB(μV)	Margin, dB*		
0.167021	47.14	38.43	65.17	-26.74	10.85	55.17	-44.32	L1	Pass
0.283724	44.92	41.69	60.77	-19.08	30.83	50.77	-19.94		
0.420326	43.84	41.77	57.49	-15.72	34.42	47.49	-13.07		
0.702526	46.21	43.29	56.00	-12.71	32.75	46.00	-13.25		
4.036213	42.98	37.17	56.00	-18.83	19.73	46.00	-26.27		
5.394282	44.96	38.50	60.00	-21.50	25.69	50.00	-24.31		
0.425431	44.87	43.02	57.39	-14.37	35.92	47.39	-11.47	L2	Pass
0.699154	46.46	43.65	56.00	-12.35	33.06	46.00	-12.94		
0.704084	46.95	43.56	56.00	-12.44	33.51	46.00	-12.49		
1.529981	44.63	40.68	56.00	-15.32	24.42	46.00	-21.58		
4.980412	45.71	38.69	56.00	-17.31	21.35	46.00	-24.65		
5.814026	45.43	37.76	60.00	-22.24	21.26	50.00	-28.74		

*- Margin = Measured emission - specification limit.

Reference numbers of test equipment used

HL 0163	HL 0447	HL1206	HL 1430	HL 1502	HL 1510		
---------	---------	--------	---------	---------	---------	--	--

Full description is given in Appendix A.

Test specification: Section 15.207(a), 15.107, Conducted emission			
Test procedure: ANSI C63.4, Section 13.1.3, Sections 11.5 and 12.1.3			
Test mode: Compliance	Verdict: PASS		
Date & Time: 6/4/2006 10:02:28 AM			
Temperature: 26 °C	Air Pressure: 1019 hPa	Relative Humidity: 37 %	Power Supply: 120VAC
Remarks: a+b/g+licened			

Plot 7.8.1 Conducted emission measurements A.C mains to MA850

LINE: L1
EUT OPERATING MODE: Transmit
LIMIT: QUASI-PEAK, AVERAGE
DETECTOR: PEAK

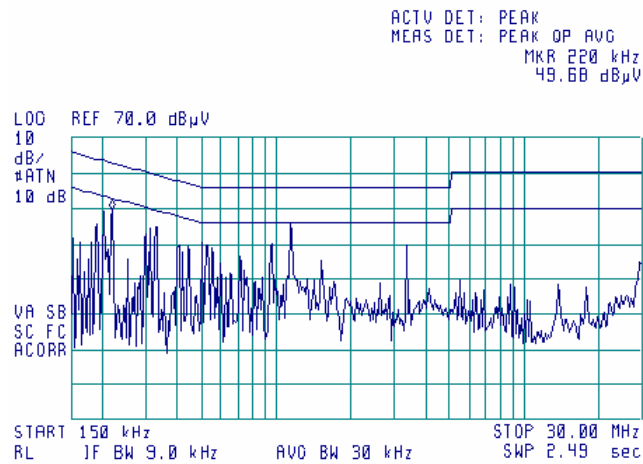

Plot 7.8.2 Conducted emission measurements A.C mains to MA850

LINE: L2
EUT OPERATING MODE: Transmit
LIMIT: QUASI-PEAK, AVERAGE
DETECTOR: PEAK

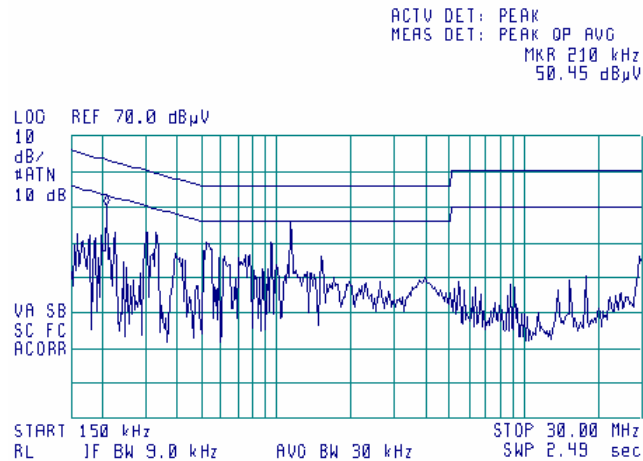

Test specification:	Section 15.207(a), 15.107, Conducted emission		
Test procedure:	ANSI C63.4, Section 13.1.3, Sections 11.5 and 12.1.3		
Test mode:	Compliance	Verdict:	PASS
Date & Time:	6/4/2006 10:02:28 AM		
Temperature: 26 °C	Air Pressure: 1019 hPa	Relative Humidity: 37 %	Power Supply: 120VAC
Remarks: a+b/g+licened			

Plot 7.8.3 Conducted emission measurements A.C mains to CISCO A.P

LINE: L1
EUT OPERATING MODE: Transmit
LIMIT: QUASI-PEAK, AVERAGE
DETECTOR: PEAK

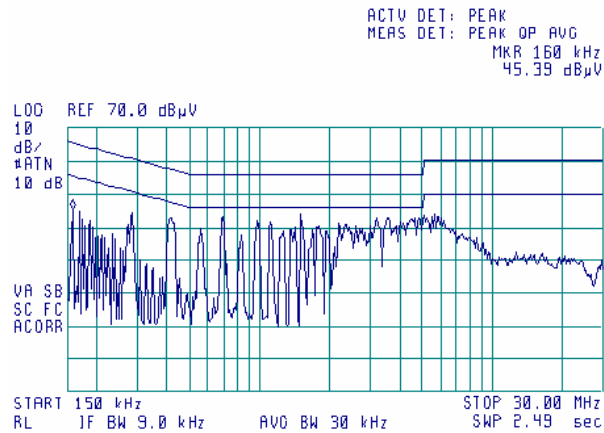

Plot 7.8.4 Conducted emission measurements A.C mains to CISCO A.P

LINE: L2
EUT OPERATING MODE: Transmit
LIMIT: QUASI-PEAK, AVERAGE
DETECTOR: PEAK

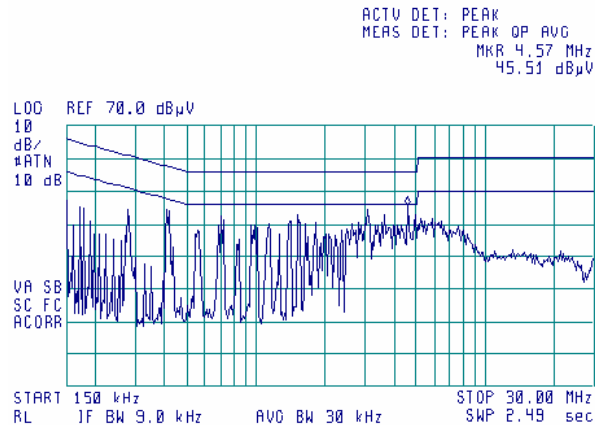

8 APPENDIX A Test equipment and ancillaries used for tests

HL No	Description	Manufacturer	Model	Ser. No.	Last Cal.	Due Cal.
0163	LISN FCC/VDE/MIL-STD	Electro-Metrics	ANS 25/2	1314	01-Oct-05	01-Oct-06
0446	Antenna, Loop active, 10kHz-30MHz	EMCO	6502	2857	28-Jun-06	28-Jun-07
0447	LISN, 16/2, 300V RMS	HL	LISN 16 - 1	066	03-Nov-05	03-Nov-06
0465	Anechoic Chamber 9(L) x 6.5(W) x 5.5(H) m	HL	AC - 1	023	11-Nov-05	11-Nov-06
0521	EMI Receiver (Spectrum Analyzer) with RF filter section 9 kHz-6.5 GHz	Hewlett Packard	8546A	3617A 00319, 3448A002 53	26-Sep-05	26-Sep-06
0589	Cable Coaxial, GORE A2P01POL118, 2.3 m	HL	GORE-3	176	02-Dec-05	02-Dec-06
0592	Position Controller	HL	L2-SR3000 (HL CRL-3)	100	18-May-06	18-May-07
0593	Antenna Mast, 1-4 m Pneumatic	Madgesh	AM-F1	101	02-Feb-06	02-Feb-07
0594	Turn Table FOR ANECHOIC CHAMBER flush mount d=1.2 m Pneumatic	HL	TT-WDC1	102	26-Jan-06	26-Jan-07
0604	Antenna BiconiLog Log-Periodic/T Bow-TIE 26 - 2000 MHz	EMCO	3141	9611-1011	10-Jan-06	10-Jan-07
1200	Quadruplexer 1-12 GHz (1-2 GHz; 2-4GHz;4-8 GHz; 8-12GHz)	Elettronica S.p.A. - Roma	UE 84	D/00240	10-Feb-06	10-Feb-07
1206	One phase voltage regulator, 2kVA, 0-250V	HL	TDGC-2	142	04-Jun-06	04-Jun-07
1430	EMI Receiver, 9 kHz - 2.9 GHz, System: HL1431, HL1432	Agilent Technologies	8542E	3807A002 62,3705A0 0217	01-Sep-05	01-Sep-06
1441	Synthesized RF Signal Generator 10 kHz - 1050 MHz	Fluke	6060B	4190210	16-Oct-05	16-Oct-06
1502	Cable RF, 6 m	Belden	M17/167 MIL-C-17	1502	02-Dec-05	02-Dec-06
1510	Cable RF, 8 m	Belden	M17/167 MIL-C-17	1510	02-Dec-05	02-Dec-06
1650	Attenuators Set (2, 3, 5, 20 dB), DC-18 GHz	M/A-COM	2082	1650	03-Jan-06	03-Jan-07
1906	Power Divider, 0.5-18.0 GHz, 80 W	Omni Spectra	2090-6204-00	1906	05-Dec-05	05-Dec-06
1947	Cable 18GHz, 6.5 m, blue	Rhophase Microwave Limited	NPS-1803A-6500-NPS	T4974	17-Oct-05	17-Oct-06
1984	Antenna, Double-Ridged Waveguide Horn, 1-18 GHz, 300 W, N-type	EMC Test Systems	3115	9911-5964	03-Mar-06	03-Mar-07
2009	Cable RF, 8 m	Alpha Wire	RG-214	C-56	02-Dec-05	02-Dec-06
2254	Cable 40GHz, 0.8 m, blue	Rhophase Microwave Limited	KPS-1503A-800-KPS	W4907	21-Jun-06	21-Jun-07
2524	Attenuator, 10 dB, DC-18 GHz	Midwest Microwave	263-10	2524	03-Jan-06	03-Jan-07
2667	Signal generator, 9 kHz - 3.3 GHz	Rohde & Schwarz	SML03	101909	24-Sep-04	24-Sep-07
2780	EMS analyzer, 100 Hz to 26.5 GHz	Agilent Technologies	E7405A	MY451024 6	11-Jun-06	11-Jun-07

HL No	Description	Manufacturer	Model	Ser. No.	Last Cal.	Due Cal.
2867	Cable, 18 GHz, 0.9 m, SMA - SMA, Right Angle	Gore	NA	91P72076	16-Feb-06	16-Feb-07
2869	Cable, 18 GHz, 1.2 m, SMA - SMA, Right Angle	Gore	NA	91P72073	16-Feb-06	16-Feb-07
2909	Spectrum analyzer, ESA-E, 100 Hz to 26.5 GHz	Agilent Technologies	E4407B	MY41444762	10-Apr-06	10-Apr-07

9 APPENDIX B Measurement uncertainties

Expanded uncertainty at 95% confidence in Hermon Labs EMC measurements

Test description	Expanded uncertainty
Conducted carrier power at RF antenna connector	Below 12.4 GHz: ± 1.7 dB 12.4 GHz to 40 GHz: ± 2.3 dB
Conducted emissions at RF antenna connector	9 kHz to 2.9 GHz: ± 2.6 dB 2.9 GHz to 6.46 GHz: ± 3.5 dB 6.46 GHz to 13.2 GHz: ± 4.3 dB 13.2 GHz to 22.0 GHz: ± 5.0 dB 22.0 GHz to 26.8 GHz: ± 5.5 dB 26.8 GHz to 40.0 GHz: ± 4.8 dB
Occupied bandwidth	± 8.0 %
Duty cycle, timing (Tx ON / OFF) and average factor measurements	± 1.0 %
Conducted emissions with LISN	9 kHz to 150 kHz: ± 3.9 dB 150 kHz to 30 MHz: ± 3.8 dB
Radiated emissions at 3 m measuring distance Horizontal polarization Vertical polarization	Biconilog antenna: ± 5.3 dB Biconical antenna: ± 5.0 dB Log periodic antenna: ± 5.3 dB Double ridged horn antenna: ± 5.3 dB Biconilog antenna: ± 6.0 dB Biconical antenna: ± 5.7 dB Log periodic antenna: ± 6.0 dB Double ridged horn antenna: ± 6.0 dB

The test equipment has been calibrated according to its recommended procedures and is within the manufacturer's published limit of error. The standards and instruments used in the calibration system conform to the present requirements of ISO/IEC 17025 (or alternately ANSI/NC SL Z540-1).

The laboratory calibrates its measurement standards by a third party (traceable to NIST, USA) on a regular basis according to equipment manufacturer requirements. The Hermon Labs EMC measurements uncertainty is given in the table above.

10 APPENDIX C Test facility description

Tests were performed at Hermon Laboratories Ltd., which is a fully independent, private, EMC, safety, environmental and telecommunication testing facility. Hermon Laboratories is listed by the Federal Communications Commission (USA) for all parts of Code of Federal Regulations 47 (CFR 47) and by Industry Canada for electromagnetic emissions (file numbers IC 2186-1 for OATS and IC 2186-2 for anechoic chamber), certified by VCCI, Japan (the registration numbers are R-808 for OATS, R-1082 for anechoic chamber, C-845 for conducted emissions site), assessed by TNO Certification EP&S (Netherlands) for a number of EMC, telecommunications, environmental, safety standards, and by AMTAC (UK) for safety of medical devices. The laboratory is accredited by American Association for Laboratory Accreditation (USA) according to ISO/IEC 17025 for electromagnetic compatibility, product safety, telecommunications testing and environmental simulation (for exact scope please refer to Certificate No. 839.01).

Address: P.O. Box 23, Binyamina 30500, Israel.
Telephone: +972 4628 8001
Fax: +972 4628 8277
e-mail: mail@hermonlabs.com
website: www.hermonlabs.com

Person for contact: Mr. Alex Usoskin, QA manager.

11 APPENDIX D Specification references

47CFR part 15: 2005	Radio Frequency Devices.
FR Vol.62	Federal Register, Volume 62, May 13, 1997
ANSI C63.2: 1996	American National Standard for Instrumentation-Electromagnetic Noise and Field Strength, 10 kHz to 40 GHz-Specifications.
ANSI C63.4: 2003	American National Standard for Methods of Measurement of Radio-Noise Emissions from Low-Voltage Electrical and Electronic Equipment in the Range of 9 kHz to 40 GHz.

12 APPENDIX E Abbreviations and acronyms

A	ampere
AC	alternating current
A/m	ampere per meter
AM	amplitude modulation
AVRG	average (detector)
cm	centimeter
dB	decibel
dBm	decibel referred to one milliwatt
dB(μ V)	decibel referred to one microvolt
dB(μ V/m)	decibel referred to one microvolt per meter
dB(μ A)	decibel referred to one microampere
dB Ω	decibel referred to one Ohm
DC	direct current
DTS	digital transmission system
EIRP	equivalent isotropically radiated power
ERP	effective radiated power
EUT	equipment under test
F	frequency
FHSS	frequency hopping spread spectrum
GHz	gigahertz
GND	ground
H	height
HL	Hermon laboratories
Hz	hertz
ITE	information technology equipment
k	kilo
kHz	kilohertz
LISN	line impedance stabilization network
LO	local oscillator
m	meter
MHz	megahertz
min	minute
mm	millimeter
ms	millisecond
μ s	microsecond
NA	not applicable
NT	not tested
OATS	open area test site
Ω	Ohm
PCB	printed circuit board
PM	pulse modulation
PS	power supply
ppm	part per million (10^{-6})
QP	quasi-peak
RE	radiated emission
RF	radio frequency
rms	root mean square
Rx	receive
s	second
T	temperature
Tx	transmit
V	volt
VA	volt-ampere

13 APPENDIX F Test equipment correction factors

**Correction factor
Line impedance stabilization network
Model ANS-25/2
Electro-Metrics**

Frequency, MHz	Correction factor, dB	Frequency, MHz	Correction factor, dB
0.01	4.7	3.0	0.1
0.02	2.1	4.0	0.1
0.03	1.1	5.0	0.1
0.04	0.7	6.0	0.1
0.05	0.5	10.0	0.1
0.1	0.2	12.0	0.1
0.2	0.1	16.0	0.1
0.4	0.1	18.0	0.1
0.6	0.1	20.0	0.1
0.8	0.1	25.0	0.1
1.0	0.1	28.0	0.1
2.0	0.1	30.0	0.1

The correction factor in dB is to be added to meter readings of an interference analyzer or a spectrum analyzer.

**Correction factor
Line impedance stabilization network
Model LISN 16 - 1
Hermon Laboratories**

Frequency, MHz	Correction factor, dB	Frequency, MHz	Correction factor, dB
0.01	5.0	3.0	0.1
0.02	2.2	4.0	0.1
0.03	1.1	5.0	0.1
0.04	0.7	6.0	0.2
0.05	0.5	10.0	0.3
0.1	0.2	12.0	0.4
0.2	0.1	16.0	0.5
0.4	0.1	18.0	0.6
0.6	0.1	20.0	0.7
0.8	0.1	25.0	0.9
1.0	0.1	28.0	1.2
2.0	0.1	30.0	1.3

The correction factor in dB is to be added to meter readings of an interference analyzer or a spectrum analyzer.

Antenna factor
Biconilog antenna EMCO, model 3141, serial number 1011, HL 0604

Frequency, MHz	Antenna factor, dB(1/m)	Frequency, MHz	Antenna factor, dB(1/m)	Frequency, MHz	Antenna factor, dB(1/m)
26	7.8	560	19.8	1300	27.0
28	7.8	580	20.6	1320	27.8
30	7.8	600	21.3	1340	28.3
40	7.2	620	21.5	1360	28.2
60	7.1	640	21.2	1380	27.9
70	8.5	660	21.4	1400	27.9
80	9.4	680	21.9	1420	27.9
90	9.8	700	22.2	1440	27.8
100	9.7	720	22.2	1460	27.8
110	9.3	740	22.1	1480	28.0
120	8.8	760	22.3	1500	28.5
130	8.7	780	22.6	1520	28.9
140	9.2	800	22.7	1540	29.6
150	9.8	820	22.9	1560	29.8
160	10.2	840	23.1	1580	29.6
170	10.4	860	23.4	1600	29.5
180	10.4	880	23.8	1620	29.3
190	10.3	900	24.1	1640	29.2
200	10.6	920	24.1	1660	29.4
220	11.6	940	24.0	1680	29.6
240	12.4	960	24.1	1700	29.8
260	12.8	980	24.5	1720	30.3
280	13.7	1000	24.9	1740	30.8
300	14.7	1020	25.0	1760	31.1
320	15.2	1040	25.2	1780	31.0
340	15.4	1060	25.4	1800	30.9
360	16.1	1080	25.6	1820	30.7
380	16.4	1100	25.7	1840	30.6
400	16.6	1120	26.0	1860	30.6
420	16.7	1140	26.4	1880	30.6
440	17.0	1160	27.0	1900	30.6
460	17.7	1180	27.0	1920	30.7
480	18.1	1200	26.7	1940	30.9
500	18.5	1220	26.5	1960	31.2
520	19.1	1240	26.5	1980	31.6
540	19.5	1260	26.5	2000	32.0
		1280	26.6		

Antenna factor in dB(1/m) is to be added to receiver meter reading in dB(μ V) to convert it into field intensity in dB(μ V/m).

Antenna factor
Double-ridged wave guide horn antenna
Model 3115, S/N 9911-5964, HL1984

Frequency, MHz	Antenna factor, dB(1/m)
1000.0	24.7
1500.0	25.7
2000.0	27.6
2500.0	28.9
3000.0	31.2
3500.0	32.0
4000.0	32.5
4500.0	32.7
5000.0	33.6
5500.0	35.1
6000.0	35.4
6500.0	34.9
7000.0	36.1
7500.0	37.8
8000.0	38.0
8500.0	38.1
9000.0	39.1
9500.0	38.3
10000.0	38.6
10500.0	38.2
11000.0	38.7
11500.0	39.5
12000.0	40.0
12500.0	40.4
13000.0	40.5
13500.0	41.1
14000.0	41.6
14500.0	41.7
15000.0	38.7
15500.0	38.2
16000.0	38.8
16500.0	40.5
17000.0	42.5
17500.0	45.9
18000.0	49.4

Antenna factor in dB(1/m) is to be added to receiver meter reading in dB(μ V) to convert it into field intensity in dB(μ V/m).

Antenna Factor
Active Loop Antenna
EMC Test Systems, model 6502, serial number 2857, HL 0446

Frequency, MHz	Magnetic Antenna Factor, dB(S/m)	Electric Antenna Factor, dB(1/m)
0.009	-32.8	18.7
0.010	-33.8	17.7
0.020	-38.3	13.2
0.050	-41.1	10.4
0.075	-41.3	10.2
0.100	-41.6	9.9
0.150	-41.7	9.8
0.250	-41.6	9.9
0.500	-41.8	9.7
0.750	-41.9	9.6
1.000	-41.4	10.1
2.000	-41.5	10.0
3.000	-41.4	10.1
4.000	-41.4	10.1
5.000	-41.5	10.0
10.000	-41.9	9.6
15.000	-41.9	9.6
20.000	-42.2	9.3
25.000	-42.8	8.7
30.000	-44.0	7.5

Antenna factor in dB(S/m) is to be added to receiver meter reading in dB(μ V) to convert it into field intensity in dB(μ A/m).
Antenna factor in dB(1/m) is to be added to receiver meter reading in dB(μ V) to convert it into field intensity in dB(μ V/m).

Cable loss
Cable Coaxial, GORE A2P01POL118, 2.3 m, model:GORE-3, HL 0589
+ Cable Coaxial, ANDREW PSWJ4, 6m, model: ANDREW-6, HL 1004

No.	Frequency, MHz	Cable loss, dB	Tolerance (Specification), dB	Measurement uncertainty, dB
1	30	0.33	≤ 6.5	±0.12
2	50	0.40		
3	100	0.57		
4	300	0.97		
5	500	1.25		
6	800	1.59		
7	1000	1.81		
8	1200	1.97		
9	1400	2.15		
10	1600	2.28		
11	1800	2.43		
12	2000	2.61		
13	2200	2.75		
14	2400	2.89		
15	2600	2.97		
16	2800	3.21	≤ 6.5	±0.12
17	3000	3.32		
18	3300	3.47		
19	3600	3.62		
20	3900	3.84		
21	4200	3.92		
22	4500	4.07		
23	4800	4.36		±0.17
24	5100	4.62		
25	5400	4.78		
26	5700	5.16		
27	6000	5.67		
28	6500	5.99		

Cable loss
Cable coaxial, 6 m, model: M17/167 MIL-C-17, HL 1502

Frequency, MHz	Cable loss, dB
0.1	0.02
1	0.07
3	0.15
5	0.17
10	0.26
30	0.43
50	0.57
80	0.72
100	0.81
300	1.48
500	2.00
800	2.70
1000	3.09

Cable loss
Cable M17/167 MIL-C-17, HL 1510

No.	Frequency, MHz	Cable loss, dB
1	0.1	0.05
2	1	0.09
3	3	0.16
4	5	0.18
5	10	0.27
6	30	0.44
7	50	0.58
8	80	0.69
9	100	0.82
10	300	1.48
11	500	2.01
12	800	2.65
13	1000	3.12

Cable loss
Cable 18 GHz, 6.5 m, blue, model: NPS-1803A-6500-NPS, S/N T4974, HL 1947

Frequency, GHz	Cable loss, dB
0.03	0.30
0.05	0.38
0.10	0.53
0.20	0.74
0.30	0.91
0.40	1.05
0.50	1.18
0.60	1.29
0.70	1.40
0.80	1.50
0.90	1.59
1.00	1.68
1.10	1.77
1.20	1.86
1.30	1.94
1.40	2.01
1.50	2.08
1.60	2.16
1.70	2.22
1.80	2.29
1.90	2.36
2.00	2.42
2.10	2.48
2.20	2.54
2.30	2.60
2.40	2.66
2.50	2.71
2.60	2.77
2.70	2.83
2.80	2.89
2.90	2.95
3.10	3.06
3.30	3.17
3.50	3.28
3.70	3.39
3.90	3.51
4.10	3.62
4.30	3.76
4.50	3.87
4.70	4.01
4.90	4.10
5.10	4.21
5.30	4.31
5.50	4.43
5.70	4.56
5.90	4.71

Frequency, GHz	Cable loss, dB
6.10	4.87
6.30	4.95
6.50	4.94
6.70	4.88
6.90	4.87
7.10	4.83
7.30	4.85
7.50	4.86
7.70	4.91
7.90	4.96
8.10	5.03
8.30	5.08
8.50	5.13
8.70	5.21
8.90	5.22
9.10	5.34
9.30	5.35
9.50	5.52
9.70	5.51
9.90	5.66
10.10	5.70
10.30	5.78
10.50	5.79
10.70	5.82
10.90	5.86
11.10	5.94
11.30	6.06
11.50	6.21
11.70	6.44
11.90	6.61
12.10	6.76
12.40	6.68
13.00	6.66
13.50	6.81
14.00	6.90
14.50	6.90
15.00	6.97
15.50	7.17
16.00	7.28
16.50	7.27
17.00	7.38
17.50	7.68
18.00	7.92

Cable loss
RF cable 8 m, model RG-214, HL 2009

No.	Frequency, MHz	Cable loss, dB	Tolerance (Specification), dB	Measurement uncertainty, dB
1	1	0.10	NA	±0.12
2	10	0.14		
3	30	0.25		
4	50	0.34		
5	100	0.53		
6	300	0.99		
7	500	1.31		
8	800	1.73		
9	1000	1.98		
10	1100	2.11		
11	1200	2.21		
12	1300	2.35		
13	1400	2.46		
14	1500	2.55		
15	1600	2.68		
16	1700	2.78		
17	1800	2.88		
18	1900	2.98		
19	2000	3.09		

Cable loss
Cable 40 GHz, 0.8 m, blue, model: KPS-1503A-800-KPS, S/N W4907, HL 2254

Frequency, GHz	Cable loss, dB	Frequency, GHz	Cable loss, dB	Frequency, GHz	Cable loss, dB
0.03	0.04	5.10	0.80	15.00	1.49
0.05	0.07	5.30	0.83	15.50	1.49
0.10	0.09	5.50	0.83	16.00	1.46
0.20	0.15	5.70	0.84	16.50	1.47
0.30	0.19	5.90	0.87	17.00	1.50
0.40	0.25	6.10	0.86	17.50	1.57
0.50	0.29	6.30	0.89	18.00	1.63
0.60	0.33	6.50	0.90	18.50	1.57
0.70	0.37	6.70	0.89	19.00	1.63
0.80	0.41	6.90	0.93	19.50	1.65
0.90	0.44	7.10	0.92	20.00	1.64
1.00	0.45	7.30	0.95	20.50	1.75
1.10	0.48	7.50	0.96	21.00	1.72
1.20	0.51	7.70	0.97	21.50	1.78
1.30	0.53	7.90	1.01	22.00	1.76
1.40	0.54	8.10	1.00	22.50	1.72
1.50	0.57	8.30	1.05	23.00	1.83
1.60	0.59	8.50	1.04	23.50	1.80
1.70	0.04	8.70	1.07	24.00	1.90
1.80	0.07	8.90	1.11	24.50	1.81
1.90	0.09	9.10	1.09	25.00	1.98
2.00	0.15	9.30	1.14	25.50	1.91
2.10	0.19	9.50	1.12	26.00	2.02
2.20	0.25	9.70	1.15	26.50	1.92
2.30	0.29	9.90	1.16	27.00	1.97
2.40	0.33	10.10	1.16	28.00	2.02
2.50	0.37	10.30	1.19	29.00	1.95
2.60	0.41	10.50	1.14	30.00	1.94
2.70	0.44	10.70	1.19	31.00	2.11
2.80	0.45	10.90	1.17	32.00	2.17
2.90	0.48	11.10	1.13	33.00	2.27
3.10	0.61	11.30	1.20	34.00	2.27
3.30	0.64	11.50	1.13	35.00	2.29
3.50	0.65	11.70	1.20	36.00	2.35
3.70	0.68	11.90	1.18	37.00	2.37
3.90	0.69	12.10	1.14	38.00	2.40
4.10	0.71	12.40	1.19	39.00	2.57
4.30	0.73	13.00	1.34	40.00	2.36
4.50	0.75	13.50	1.33		
4.70	0.77	14.00	1.48		
4.90	0.79	14.50	1.45		

Cable loss
Cable coaxial, Gore, 18 GHz, 0.9 m, SMA - SMA, model Right Angle,
HL 2867

Frequency, GHz	Cable loss, dB	Frequency, GHz	Cable loss, dB	Frequency, GHz	Cable loss, dB
10	0.06	5750	0.68	12000	1.06
30	0.04	6000	0.69	12250	1.07
100	0.07	6250	0.70	12500	1.09
250	0.14	6500	0.73	12750	1.09
500	0.19	6750	0.74	13000	1.15
750	0.22	7000	0.78	13250	1.17
1000	0.26	7250	0.77	13500	1.16
1250	0.27	7500	0.79	13750	1.17
1500	0.31	7750	0.81	14000	1.14
1750	0.35	8000	0.86	14250	1.13
2000	0.38	8250	0.86	14500	1.06
2250	0.41	8500	0.87	14750	1.12
2500	0.43	8750	0.87	15000	1.16
2750	0.46	9000	0.88	15250	1.11
3000	0.48	9250	0.89	15500	1.06
3250	0.51	9500	0.90	15750	1.12
3500	0.53	9750	0.94	16000	1.20
3750	0.55	10000	1.00	16250	1.25
4000	0.56	10250	1.01	16500	1.24
4250	0.58	10500	1.02	16750	1.34
4500	0.60	10750	1.01	17000	1.35
4750	0.62	11000	1.01	17250	1.35
5000	0.64	11250	1.01	17500	1.36
5250	0.67	11500	1.01	17750	1.40
5500	0.68	11750	1.05	18000	1.51