

**DATE: 22 January 2007**

**I.T.L. (PRODUCT TESTING) LTD.  
FCC EMC/Radio Test Report  
for  
Mobile Access Networks**

**Equipment under test:**

**Mobile Telephone In-Building  
Distribution System**

**1200-PCS-AO**

Written by:   
D. Shidlow, Documentation

Approved by:   
E. Pitt, Test Engineer

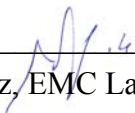
Approved by:   
I. Raz, EMC Laboratory Manager

This report must not be reproduced, except in full, without the written permission of I.T.L. (Product Testing) Ltd.

This report relates only to items tested.



## Measurement/Technical Report for Mobile Access Networks

### Mobile Telephone In-Building Distribution System

1200-PCS-AO

**FCC ID:OJFMA1200**

22 January 2007

This report concerns:                      Original Grant                       Class II change:  X

Class B verification                       Class A verification                       Class I change

Equipment type:                                      PCS Licensed Transmitter

Request Issue of Grant:  
 x Immediately upon completion of review

Limits used:  
CISPR 22                                       Part 24  x

Measurement procedure used is ANSI C63.4-2003.

Substitution Method used as in ANSI/TIA-603-B: 2002

Application for Certification

Applicant for this device:

prepared by:

(different from "prepared by")

Ishaishou Raz  
ITL (Product Testing) Ltd.  
Kfar Bin Nun  
D.N. Shimshon 99780

Shai Rachamim  
Mobile Access Networks  
Ofek 1 Center, Bldg.B  
Northern Industrial Zone,  
Lod, 71293

Israel  
e-mail Sraz@itl.co.il

Israel  
Tel: +972-8-918-3888  
Fax: +972-4-918-3844  
e-mail: ShaiR@mobileaccess.com

# TABLE OF CONTENTS

<b>1.</b>	<b>GENERAL INFORMATION</b> -----	<b>4</b>
1.1	Administrative Information.....	4
1.2	List of Accreditations.....	5
1.3	Product Description.....	6
1.4	Test Methodology.....	6
1.5	Test Facility.....	6
1.6	Measurement Uncertainty.....	6
<b>2.</b>	<b>PRODUCT LABELING</b> -----	<b>7</b>
<b>3.</b>	<b>SYSTEM TEST CONFIGURATION</b> -----	<b>8</b>
3.1	Justification.....	8
3.2	EUT Exercise Software.....	8
3.3	Special Accessories.....	8
3.4	Equipment Modifications.....	8
3.5	Configuration of Tested System.....	9
<b>4.</b>	<b>BLOCK DIAGRAM</b> -----	<b>10</b>
4.1	Schematic Block/Connection Diagram.....	10
4.2	Theory of Operation.....	10
<b>5.</b>	<b>PEAK OUTPUT POWER</b> -----	<b>11</b>
5.1	Test Specification.....	11
5.2	Test procedure.....	11
5.3	Results table.....	13
5.4	Test Equipment Used.....	14
<b>6.</b>	<b>OCCUPIED BANDWIDTH</b> -----	<b>15</b>
6.1	Test Specification.....	15
6.2	Test Procedure.....	15
6.3	Results Table.....	18
6.4	Test Equipment Used.....	19
<b>7.</b>	<b>OUT OF BAND EMISSIONS AT ANTENNA TERMINALS</b> -----	<b>20</b>
7.1	Test Specification.....	20
7.2	Test procedure.....	20
7.3	Results table.....	24
7.4	Test Equipment Used.....	25
<b>8.</b>	<b>BAND EDGE SPECTRUM</b> -----	<b>26</b>
8.1	Test Specification.....	26
8.2	Test procedure.....	26
8.3	Results table.....	27
8.4	Test Equipment Used.....	28
<b>9.</b>	<b>APPENDIX A CORRESPONDENCE WITH FCC O.E.T.</b> -----	<b>29</b>

# 1. General Information

## 1.1 Administrative Information

Manufacturer:	Mobile Access Networks
Manufacturer's Address:	Ofek 1 Center,Bldg.B Northern Industrial Zone Lod, 71293 Israel Tel: +972-8-918-3888 Fax: +972-8-918-3844
Manufacturer's Representative:	Shai Rachamim
Equipment Under Test (E.U.T):	Mobile Telephone In-Building Distribution System
Equipment Model No.:	1200-PCS-AO
Equipment Serial No.:	Not Designated
Date of Receipt of E.U.T:	18.12.06
Start of Test:	18.12.06
End of Test:	18.12.06
Test Laboratory Location:	I.T.L (Product Testing) Ltd. Kfar Bin Nun, ISRAEL 99780
Test Specifications:	FCC Part 24, Sub-part E

## **1.2 List of Accreditations**

The EMC laboratory of I.T.L. is accredited by the following bodies:

1. The American Association for Laboratory Accreditation (A2LA) (U.S.A.), Certificate No. 1152.01.
2. The Federal Communications Commission (FCC) (U.S.A.), Registration No. 90715.
3. The Israel Ministry of the Environment (Israel), Registration No. 1104/01.
4. The Voluntary Control Council for Interference by Information Technology Equipment (VCCI) (Japan), Registration Numbers: C-1350, R-1285.
5. Industry Canada (Canada), File No. IC 4025.
6. TUV Product Services, England, ASLLAS No. 97201.
7. Nemko (Norway), Authorization No. ELA 207.

I.T.L. Product Testing Ltd. is accredited by the American Association for Laboratory Accreditation (A2LA) and the results shown in this test report have been determined in accordance with I.T.L.'s terms of accreditation unless stated otherwise in the report.

### **1.3 Product Description**

See details Original Grant application.

The modulation was changed from CDMA to WCDMA.

### **1.4 Test Methodology**

Both conducted and radiated testing were performed according to the procedures in ANSI C63.4: 2003. Radiated testing was performed at an antenna to EUT distance of 3 meters.

### **1.5 Test Facility**

The radiated emissions tests were performed at I.T.L.'s testing facility at Kfar Bin-Nun, Israel. This site is a FCC listed test laboratory (FCC Registration No. 90715, date of listing December 12, 2003).

I.T.L.'s EMC Laboratory is also accredited by A2LA, certificate No. 1152.01.

### **1.6 Measurement Uncertainty**

Radiated Emission

The Open Site complies with the  $\pm 4$  dB Normalized Site Attenuation requirements of ANSI C63.4-2003. In accordance with Paragraph 5.4.6.1 of this standard, this tolerance includes instrumentation calibration errors, measurement technique errors, and errors due to site anomalies.

## 2. Product Labeling

See details in original application.

## 3. System Test Configuration

### 3.1 *Justification*

See details in original application.

Peak Output Power, Occupied Bandwidth, Out of Band Emission at Antenna Terminals, and Band Edges were re-tested according to correspondence with the FCC O.E.T. (See Appendix A).

### 3.2 *EUT Exercise Software*

See details in original application.

### 3.3 *Special Accessories*

See details in original application.

### 3.4 *Equipment Modifications*

See details in original application.



### 3.5 Configuration of Tested System

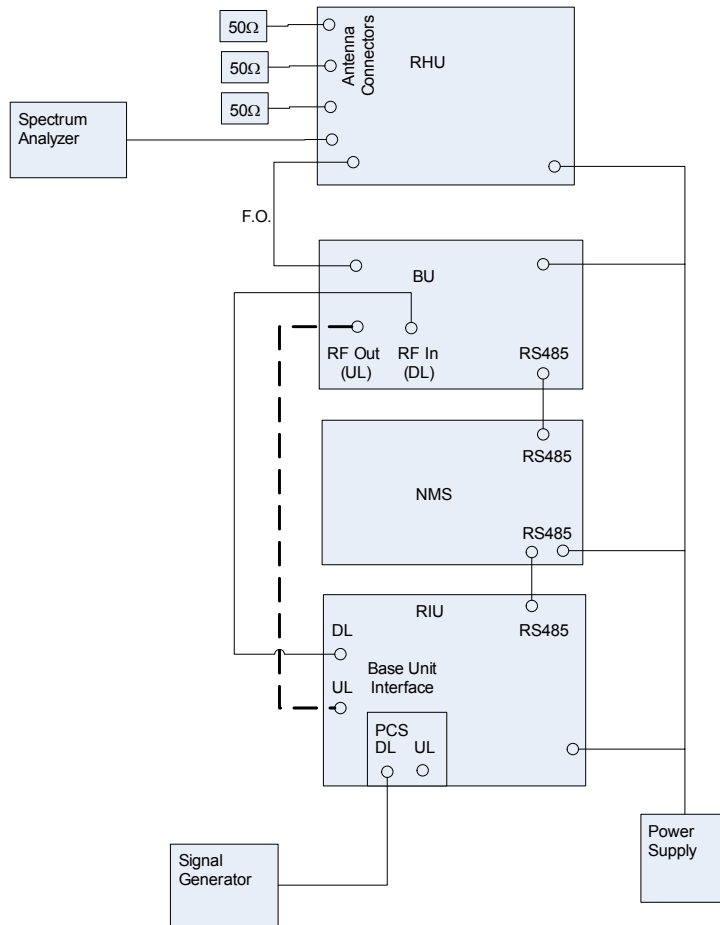

**Figure 1. Tests Set-up**

## 4. Block Diagram

### 4.1 *Schematic Block/Connection Diagram*

See original application.

### 4.2 *Theory of Operation*

See original application.

## 5. Peak Output Power

### 5.1 Test Specification

FCC Part 24, Sub-part E

### 5.2 Test procedure

Peak Power Output must not exceed 100 Watts (50dBm).

The E.U.T. antenna terminal was connected to the Spectrum Analyzer through an external attenuator (24 dB) and an appropriate coaxial cable (1 dB). The E.U.T. RF output was WCDMA modulated. Special attention was taken to prevent Spectrum Analyzer RF input overload. The Spectrum Analyzer was set to 3.0 MHz resolution BW. The output power level was measured at 1932.50, 1960.00, and 1987.50 MHz.

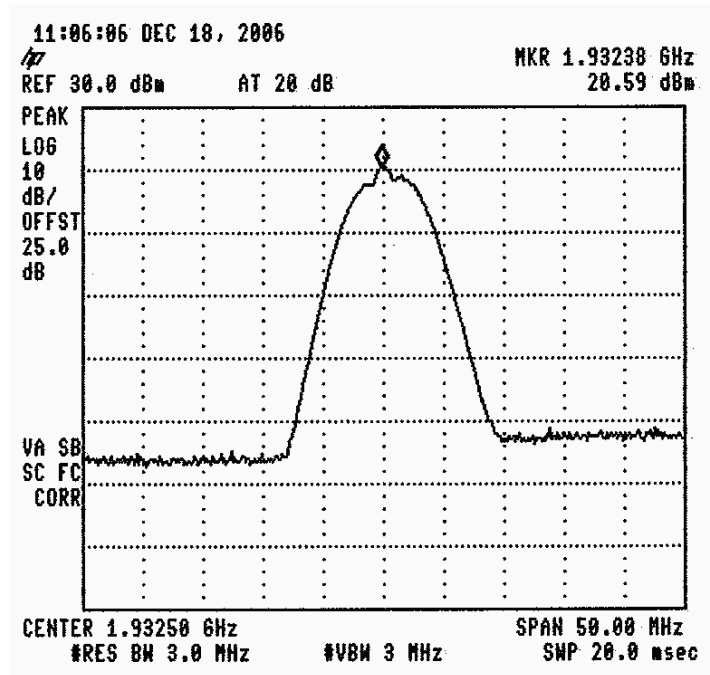

Figure 2.— 1932.50 MHz

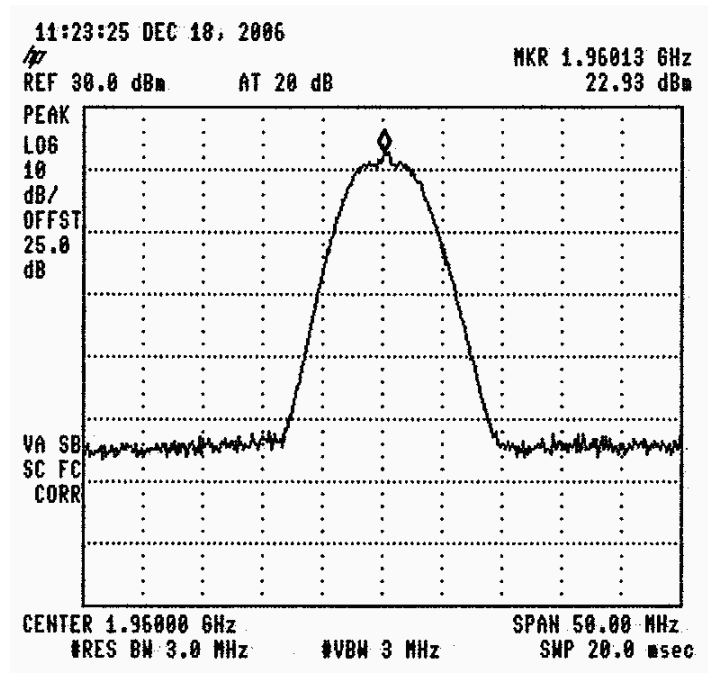

Figure 3.— 1960.00 MHz

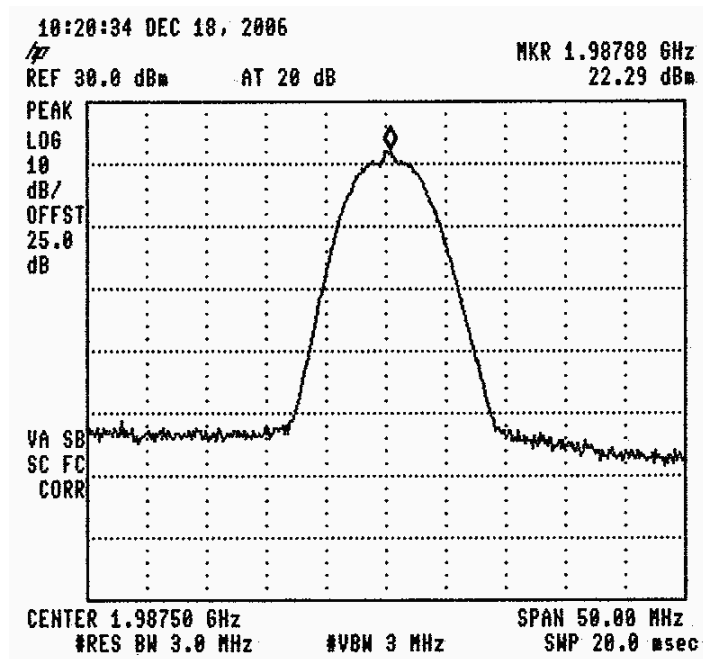

Figure 4.— 1987.50 MHz

**5.3 Results table**

E.U.T. Description: Mobile Telephone In-Building Distribution System  
 Model No.: 1200-PCS-AO  
 Serial Number: Not Designated  
 Specification: FCC Part 24, Sub-part E, Section 232, FCC Part 2, Section 1046

Operation Frequency (MHz)	Reading (dBm)	Specification (dBm)	Margin (dB)
1932.50	20.59	50.0	-29.41
1960.00	22.93	50.0	-27.07
1987.50	22.29	50.0	-27.71

**Figure 5 Peak Output Power**

JUDGEMENT: Passed by 27.07 dB

TEST PERSONNEL:

Tester Signature: *E. Pitt*

Date: 23.01.07

Typed/Printed Name: E. Pitt

#### 5.4 Test Equipment Used.

Peak Output Power

Instrument	Manufacturer	Model	Serial Number	Calibration	
				Last Calibr.	Period
Spectrum Analyzer	HP	8564E	3442A00275	21 November 2006	1 year
Signal Generator	HP	E4432B	TE0624	10 April 2006	1 year
Power Supply	Horizon Electronics	DHR 3653D-1.0	TE1232	N/A	1 year
Cable	RHOPHASE	KPS-1500	A1675	16 December 2006	1 year
Attenuator	Macom	2082-4381-08	050	26 November 2006	1 year
Attenuator	Macom	2082-4381-08	056	26 November 2006	1 year
Attenuator	Macom	2082-4381-08	211	26 November 2006	1 year

**Figure 6 Test Equipment Used**

## 6. Occupied Bandwidth

### 6.1 Test Specification

FCC Part 2, Section 1049

### 6.2 Test Procedure

The E.U.T. was set to the applicable test frequency with WCDMA modulation. The E.U.T. antenna terminal was connected to the spectrum analyzer through an external attenuator (at the output test) and an appropriate coaxial cable. The spectrum analyzer was set to 100 kHz resolution B.W.

The occupied bandwidth, that is the frequency bandwidth such that, below its lower and above its upper frequency limit, the mean powers radiated are each equal to 0.5% of the total mean power radiated by a given emission.

The occupied bandwidth of the E.U.T. at the points of 20 dB below maximum peak power was measured and recorded.

Occupied bandwidth measured was repeated in the input terminal of the E.U.T.

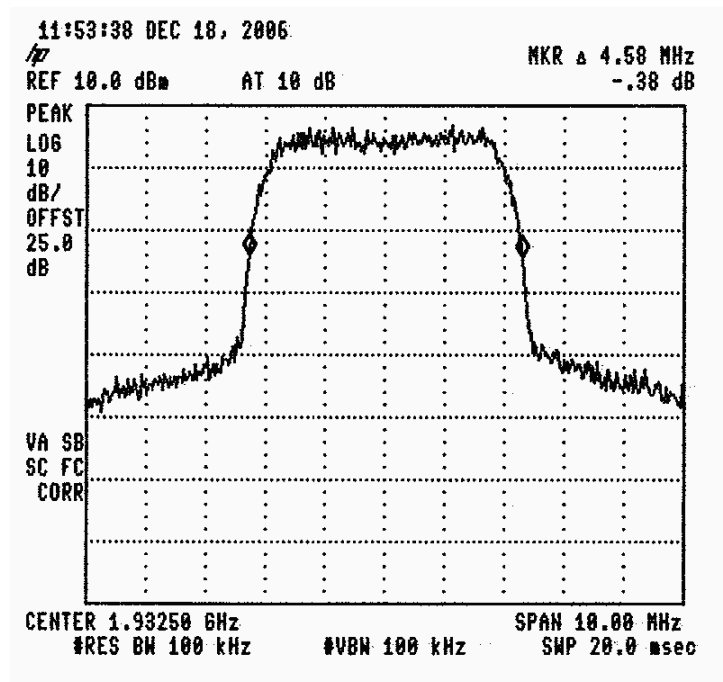

Figure 7.— Input 1932.50 MHz

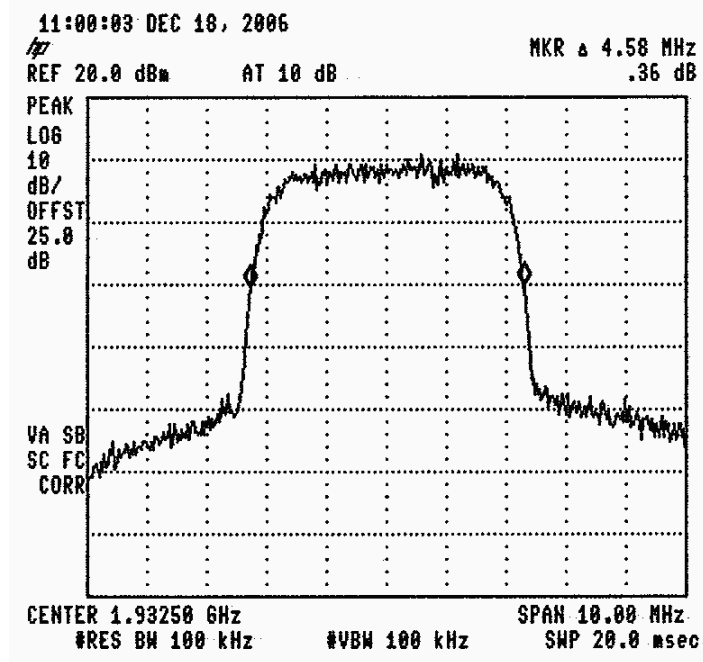

Figure 8.— Output 1932.50 MHz

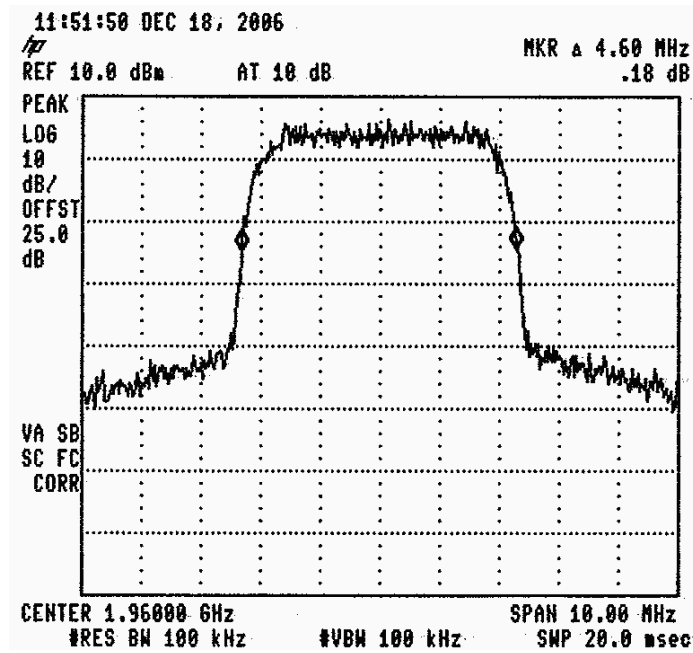

Figure 9.— Input 1960.00 MHz



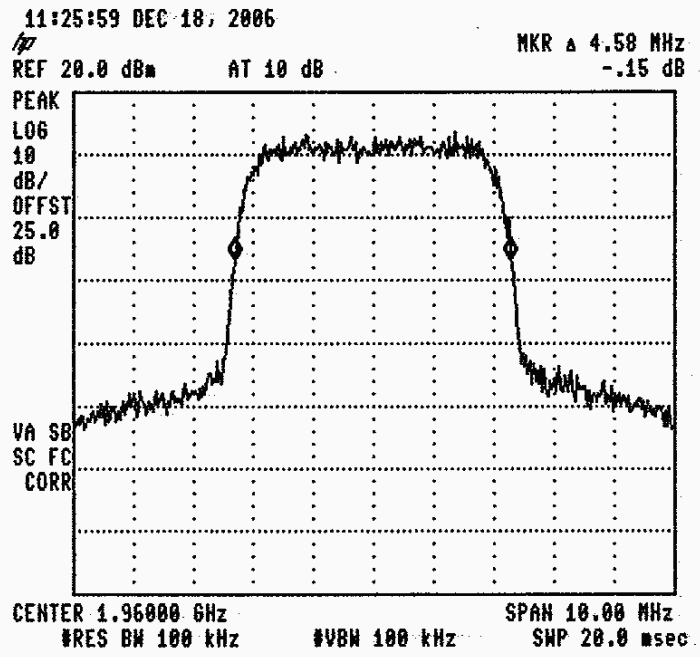

Figure 10.— Output 1960.00 MHz

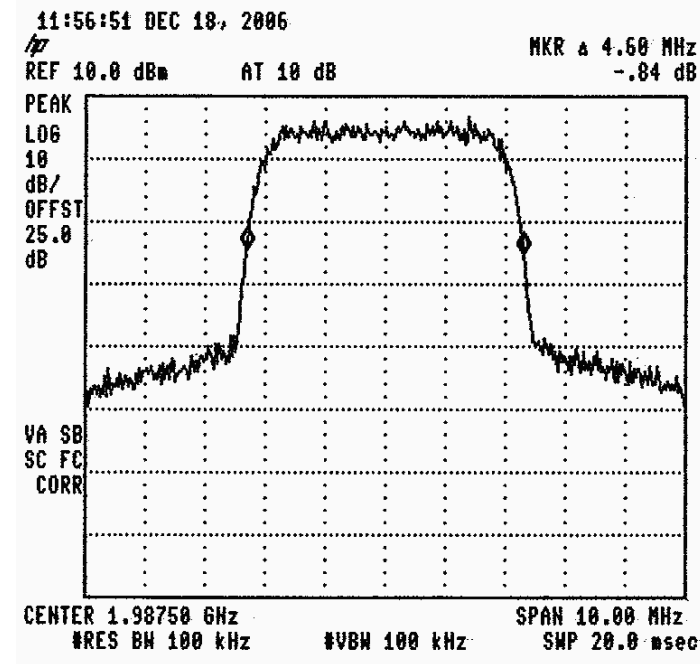

Figure 11.— Input 1987.50 MHz

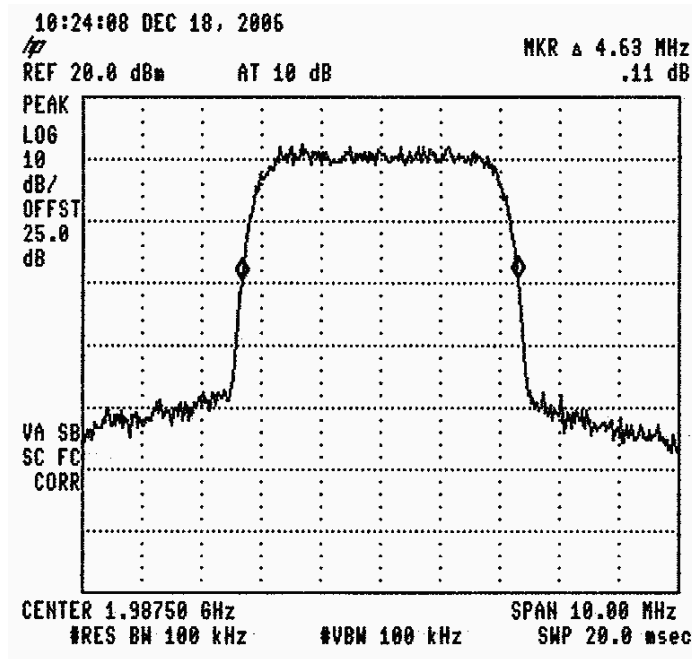

Figure 12.— Output 1987.50 MHz

### 6.3 Results Table

E.U.T. Description: Mobile Telephone In-Building Distribution System  
 Model No.: 1200-PCS-AO  
 Serial Number: Not Designated  
 Specification: FCC Part 2, Section 1049

	Operating Frequency	Reading (MHz)
Input	1932.50	4.58
Output	1932.50	4.58
Input	1960.00	4.60
Output	1960.00	4.58
Input	1987.50	4.60
Output	1987.50	4.63

Figure 13 Occupied Bandwidth

TEST PERSONNEL:

Tester Signature: *E. Pitt*

Date: 23.01.07

Typed/Printed Name: E. Pitt

## 6.4 Test Equipment Used.

### Occupied Bandwidth

Instrument	Manufacturer	Model	Serial Number	Calibration	
				Last Calibr.	Period
Spectrum Analyzer	HP	8564E	3442A00275	21 November 2006	1 year
Signal Generator	HP	E4432B	TE0624	10 April 2006	1 year
Power Supply	Horizon Electronics	DHR 3653D-1.0	TE1232	N/A	1 year
Cable	RHOPHASE	KPS-1500	A1675	16 December 2006	1 year
Attenuator	Macom	2082-4381-08	050	26 November 2006	1 year
Attenuator	Macom	2082-4381-08	056	26 November 2006	1 year
Attenuator	Macom	2082-4381-08	211	26 November 2006	1 year

**Figure 14 Test Equipment Used**

## 7. Out of Band Emissions at Antenna Terminals

### 7.1 Test Specification

FCC Part 24, Sub-part E, Section 238; FCC Part 2.1051

### 7.2 Test procedure

The power of any emission outside of the authorized operating frequency ranges (1930-1990 MHz) must be attenuated below the transmitting power (P) by a factor of at least  $43 + \log(P)$  dB, yielding  $-13\text{dBm}$ .

The E.U.T. antenna terminal was connected to the spectrum analyzer through an external attenuator and an appropriate coaxial cable (25.0 dB).

The spectrum analyzer was set to 100 kHz resolution B.W.

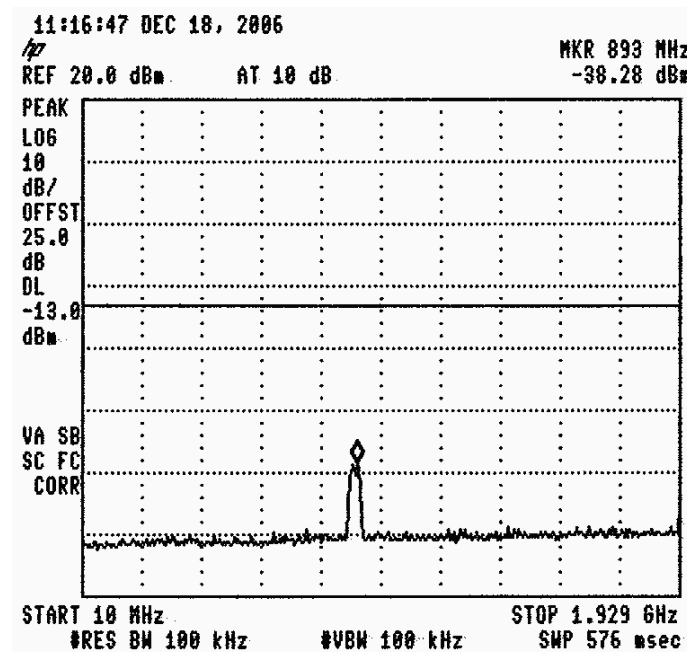

Figure 15.— 1932.50 MHz

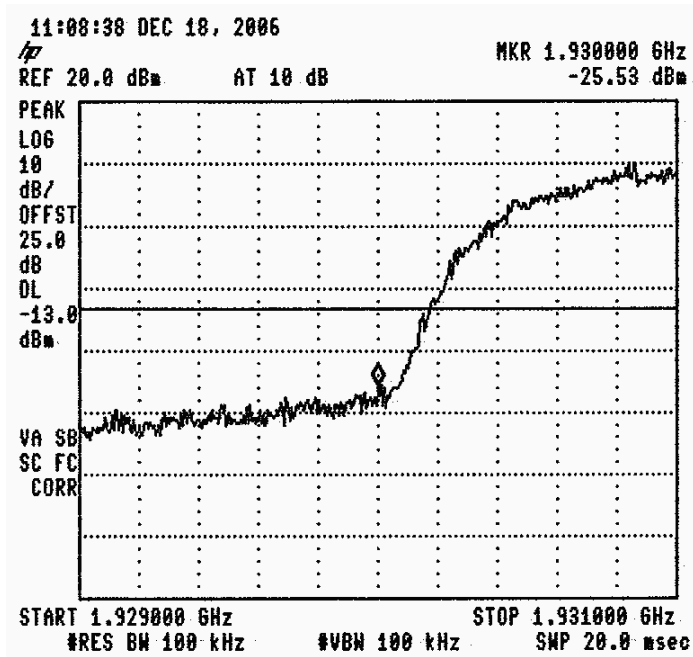

Figure 16.— 1932.50 MHz

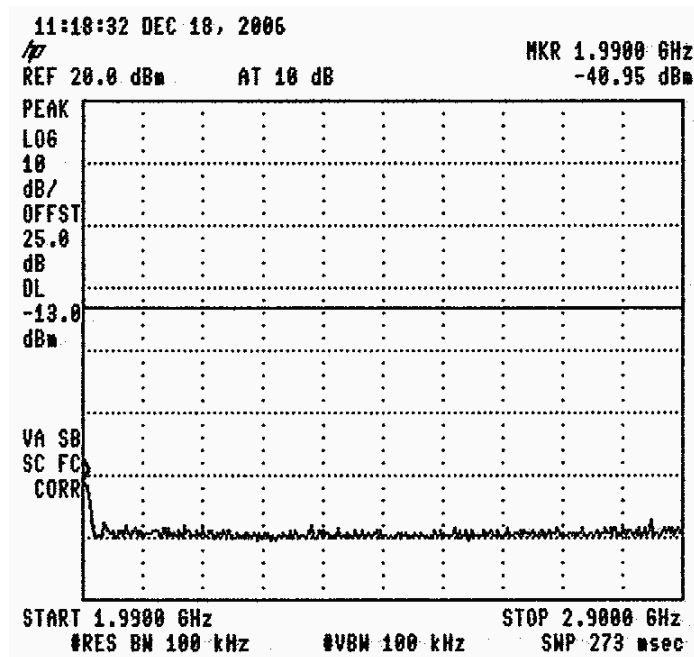

Figure 17.— 1932.50 MHz

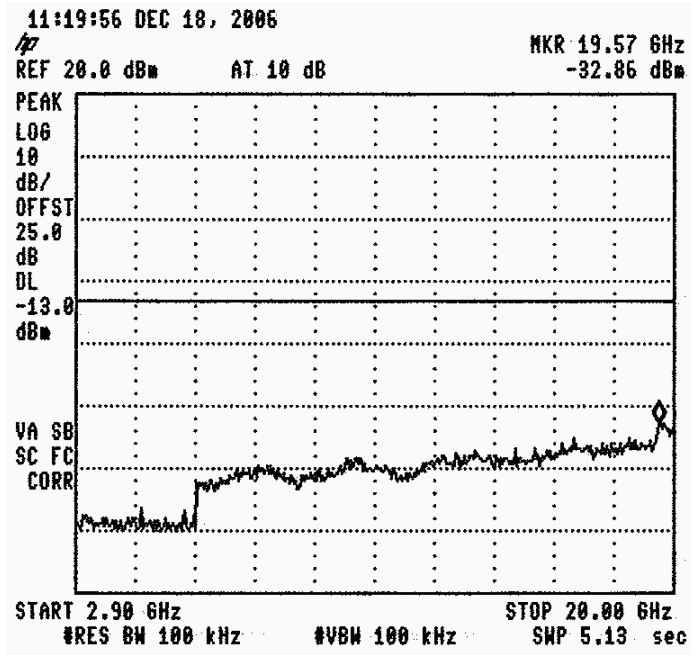

Figure 18.— 1932.50 MHz

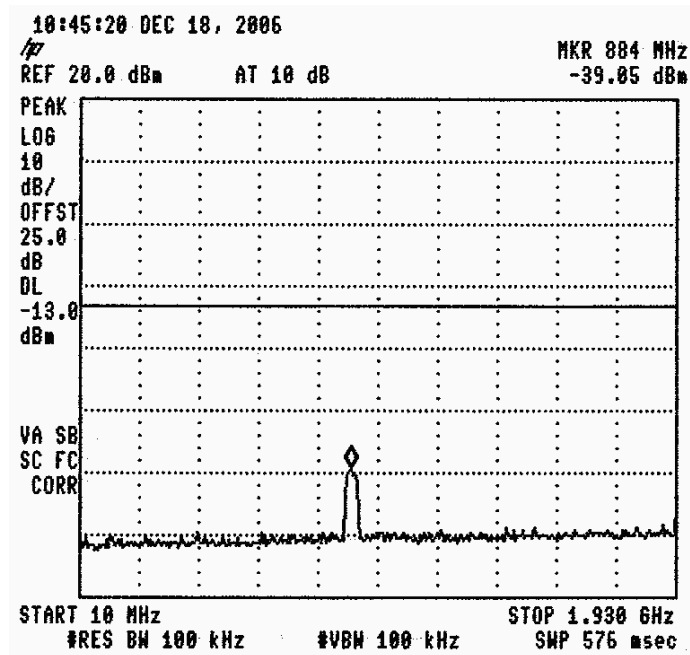

Figure 19.— 1987.50 MHz

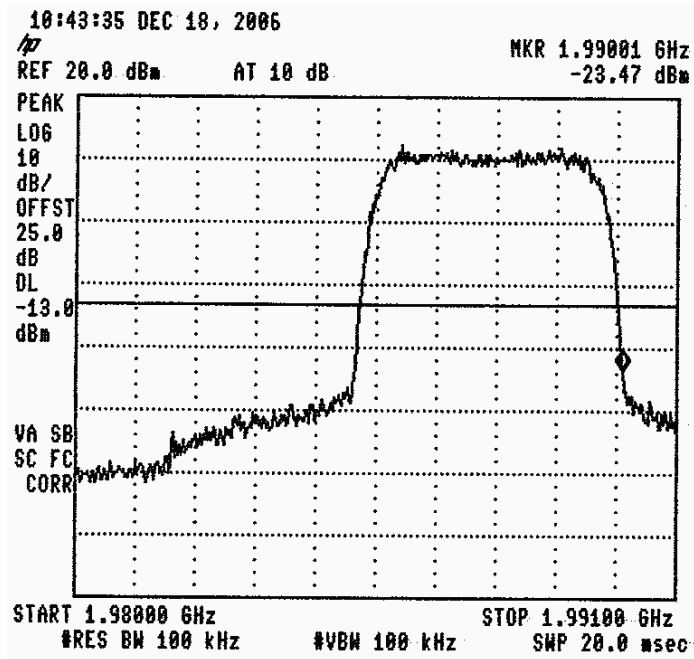

Figure 20.— 1987.50 MHz

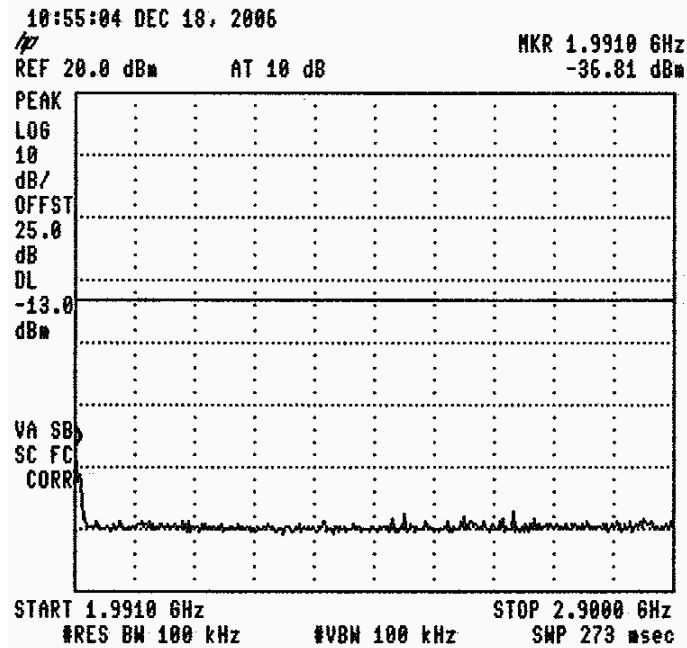

Figure 21.— 1987.50 MHz

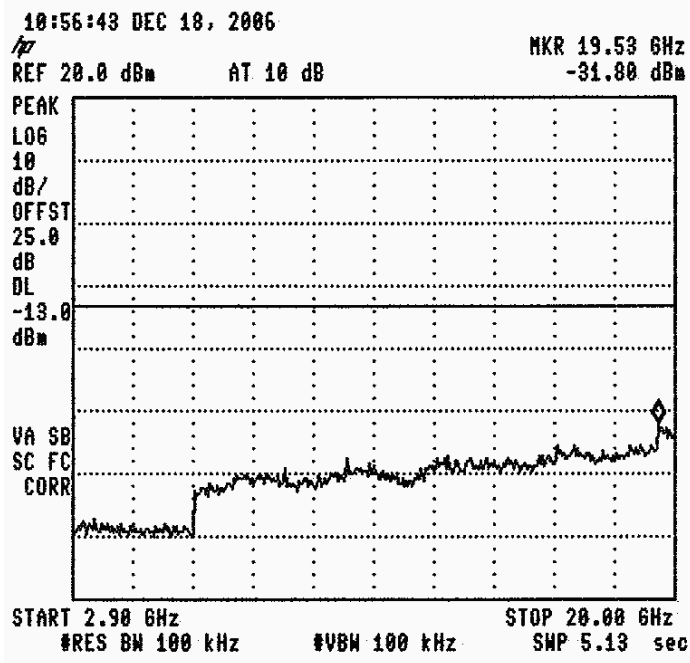

Figure 22.— 1987.50 MHz

### 7.3 Results table

E.U.T. Description: Mobile Telephone In-Building Distribution System  
 Model No.: 1200-PCS-AO  
 Serial Number: Not Designated  
 Specification: FCC Part 24, Sub-part E, Section 238; Part 2 Section 1051

Operation Frequency (MHz)	Reading (dBm)	Specification (dBm)	Margin (dB)
1932.50	32.86	-13.0	-19.86
1987.50	23.47	-13.0	-10.47

Figure 23 Out of Band Emission Results

JUDGEMENT: Passed by 10.47 dB

TEST PERSONNEL:

Tester Signature: *E. Pitt*

Date: 23.01.07

Typed/Printed Name: E. Pitt



#### 7.4 Test Equipment Used.

##### Out of Band Emission at Antenna Terminals

Instrument	Manufacturer	Model	Serial Number	Calibration	
				Last Calibr.	Period
Spectrum Analyzer	HP	8564E	3442A00275	21 November 2006	1 year
Signal Generator	HP	E4432B	TE0624	10 April 2006	1 year
Power Supply	Horizon Electronics	DHR 3653D-1.0	TE1232	N/A	1 year
Cable	RHOPHASE	KPS-1500	A1675	16 December 2006	1 year
Attenuator	Macom	2082-4381-08	050	26 November 2006	1 year
Attenuator	Macom	2082-4381-08	056	26 November 2006	1 year
Attenuator	Macom	2082-4381-08	211	26 November 2006	1 year

**Figure 24 Test Equipment Used**

## 8. Band Edge Spectrum

### 8.1 Test Specification

FCC Part 24, Sub-part E, Section 238; FCC Part 2.1051

### 8.2 Test procedure

Enclosed are spectrum analyzer plots for the lowest operation frequency (1932.5 MHz) and the highest operation frequency (1987.5 MHz) in which the E.U.T. is planned to be used.

The power of any emission outside of the authorized operating frequency ranges (1932.50-1987.50 MHz) must be attenuated below the transmitting power (P) by a factor of at least  $43 + \log(P)$  dB, yielding  $-13\text{dBm}$ .

The E.U.T. antenna terminal was connected to the spectrum analyzer through an external attenuator and an appropriate coaxial cable (25.0 dB).

The spectrum analyzer was set to 100 kHz resolution B.W.

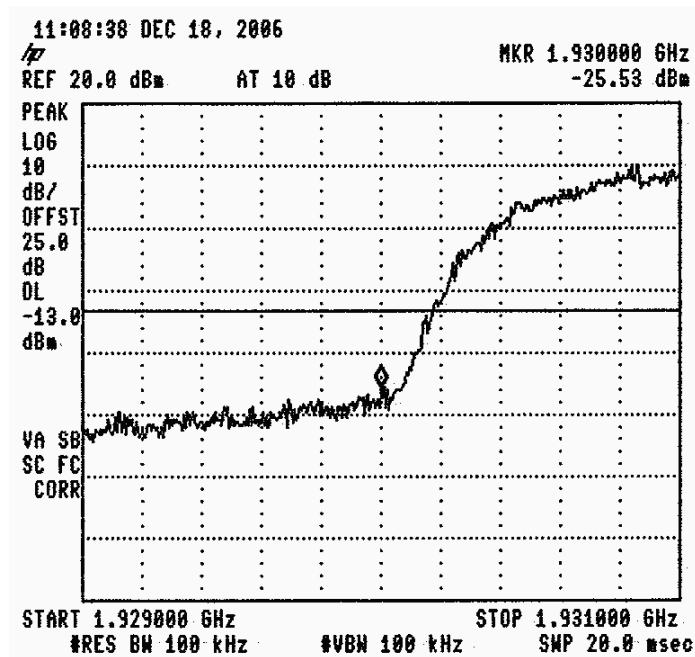

Figure 25.— 1932.50 MHz

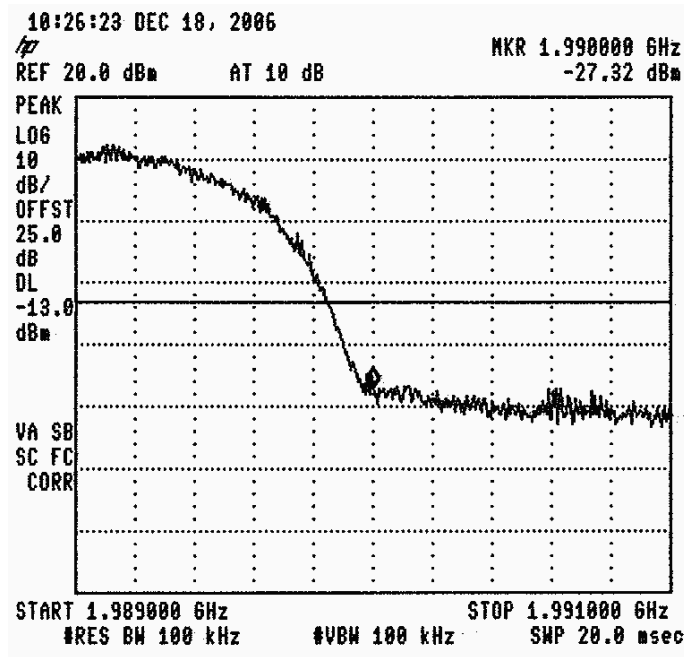

Figure 26.— 1987.50 MHz

### 8.3 Results table

E.U.T. Description: Mobile Telephone In-Building Distribution System  
 Model No.: 1200-PCS-AO  
 Serial Number: Not Designated  
 Specification: FCC Part 24, Sub-part E, Section 238; Part 2 Section 1051

Operation Frequency (MHz)	Band Edge Frequency (MHz)	Reading (dBm)	Specification (dBm)	Margin (dB)
1932.50	1930.00	-25.53	-13.0	-12.53
1960.00	1990.00	-27.32	-13.0	-14.32

Figure 27 Band Edge Spectrum Results

JUDGEMENT: Passed by 12.53 dB

TEST PERSONNEL:

Tester Signature: *E. Pitt*

Date: 23.01.07

Typed/Printed Name: E. Pitt

### 8.4 Test Equipment Used.

#### Band Edge Spectrum

Instrument	Manufacturer	Model	Serial Number	Calibration	
				Last Calibr.	Period
Spectrum Analyzer	HP	8564E	3442A00275	21 November 2006	1 year
Signal Generator	HP	E4432B	TE0624	10 April 2006	1 year
Power Suppy	Horizon Electronics	DHR 3653D-1.0	TE1232	N/A	1 year
Cable	RHOPHASE	KPS-1500	A1675	16 December 2006	1 year
Attenuator	Macom	2082-4381-08	050	26 November 2006	1 year
Attenuator	Macom	2082-4381-08	056	26 November 2006	1 year
Attenuator	Macom	2082-4381-08	211	26 November 2006	1 year

**Figure 28 Test Equipment Used**

## 9. Appendix A Correspondence With FCC O.E.T.

Date: 12.01.2007

To: EMC

Subject: Response to Inquiry to FCC (Tracking Number 587924)

Inquiry:

1. Two products were authorized to Parts 24E, and 24E and 22H respectively. These products were authorized using CDMA modulation. Our customer would like to authorize the products using WCDMA modulation instead of CDMA modulation. **No hardware changes have been made to the products.**

2. The original FCC ID #'s of the products are:

FCC ID OJFMA1200 and OJFMA1K-CELL-PCSE

3. Questions:

3.1. Is Permissive Change Class II OK?

3.2. Is testing of:

Occupied Bandwidth; Out of band (Band Edges), and Peak Power acceptable?

Thanks for your help.

Response:

As long as there NO changes to the transmitter a class II permissive change is acceptable. A test report must be submitted showing measurements of occupied bandwidth, band edge, peak power, and spurious emission.